

# Kelly Tillage System 9m

## Operating Instruction Manual

Model number: 1532-KDH-E  
Serial number:



Register within 2 months of purchasing the machine to receive an additional 12 months warranty.

Find the registration information on page 9

Revision A

Kelly Engineering  
PO Box 100  
Booleroo Centre  
South Australia 5482

Email: [sales@kellytillage.com](mailto:sales@kellytillage.com)  
Website: [www.kellytillage.com](http://www.kellytillage.com)

# Contents

|  | <b>Page no</b> |
|--|----------------|
| <b>Safety Information</b>                                | 4              |
| Signal words   | 5              |
| Safety Guidelines  | 5              |
| General Operation  | 6              |
| Transport  | 6              |
| Hydraulics   | 6              |
| Maintenance & Inspection                                 | 6              |
| <br>   |                |
| <b>Section 1 - Warranty</b>                              | 7              |
| Warranty Policy  | 8              |
| Product Registration Form                                | 9              |
| Thank you for choosing a Kelly                           | 10             |
| Contact Information                                      | 10             |
| <br>   |                |
| <b>Section 2 - Machine Operation</b>                     | 11             |
| Before operation   | 12             |
| Pre-operation checklist                                  | 12             |
| Machine set up prior to operating                        | 12             |
| Park Brake   | 13             |
| Brake Setup  | 14             |
| Basic Operation - Important Locations                    | 15             |
| Basic Operation - Unfolding                              | 16 - 19        |
| Basic Operation - Folding                                | 20 - 22        |
| <br>   |                |
| <b>Section 3 - Chain Operation &amp; Correct Setup</b>   | 23             |
| Importance of Chain Tension                              | 24             |
| Chain Tension - Modules                                  | 24 - 25        |
| Chain Tension - Wings                                    | 26             |
| Chain Tension - Front Chains                             | 27             |
| Chain Tension - Rear Chains with Hydraulic De-Tensioning | 28             |
| Chain Curve  | 29             |
| Correct Chain Height Adjustment                          | 30             |
| Height adjustment for rear chain wing mounts             | 31             |
| Chain Mount Plate Height Adjustment                      | 32             |
| Front A Frame Height Adjustment                          | 33             |
| Chain Mount Plate Rear Height Adjustment                 | 33             |
| Fine adjustment for perfect operating results            | 34             |
| <br>   |                |
| <b>Section 4 - Hydraulic Sequence Valves</b>             | 35             |
| Sequence Valve Overview                                  | 36             |
| Sequence Valve Manifold - Flow Chart                     | 37             |
| Explanation of Valve Function                            | 38             |
| Factory setting: Table for V12 Sequence Valve Manifolds  | 39             |
| HF111938-16, V12 - Split Circuit                         | 40             |
| Over/Centre valves                                       | 41             |
| Check Valves   | 41             |

# Contents

|   | <b>Page no</b> |
|---|----------------|
| <b>Section 5 - Maintenance &amp; Inspection</b> | 42             |
| Maintenance and Inspection                      | 43             |
| Intervals                                       | 43 - 44        |
| Chain Inspection                                | 45             |
| Trouble Shooting                                | 45 - 46        |
| Trouble Shooting - Hydraulic Sequence Valves    | 46 - 55        |
| <b>Section 6 - Specifications</b>               | 56             |
| Operating Speed                                 | 57             |
| Tyre Pressure                                   | 57             |
| Bolt Torque Settings                            | 57             |
| Disc Chain Lengths and Quantities               | 58             |

## Safety Information



**Read all operating instructions and study all photographs thoroughly before operating the unit**

**Please note:**

Left and right is determined by standing behind the machine and looking to the front.



## Signal Words

A signal word - **DANGER**, **WARNING**, or **CAUTION**, is used with the safety alert symbol.

When you see these symbols on your machine or in this manual, be alert to instructions involving your personal safety and the safety of others.

Failure to follow these instructions can result in injury or death.



**DANGER** - Indicates an immediate hazardous situation that, if not avoided, will result in **DEATH OR SERIOUS INJURY**.



**WARNING** - Indicates a potentially hazardous situation that, if not avoided, could result in **DEATH OR SERIOUS INJURY**.



**CAUTION** - Indicates a potentially hazardous situation that, if not avoided, may result in a **MINOR OR MODERATE INJURY**.

Carefully read all safety points in this manual and on your machine. Keep all safety decals in good condition and replace ones that have been worn or lost. Replacement decals are available by contacting your local dealer.

## Safety Guidelines

- This equipment is dangerous to persons unfamiliar with its operation.
- Do not attempt to operate or assemble this unit without reading this manual and developing a thorough understanding of the safety precautions.
- Do not attempt to operate this equipment under the influence of drugs or alcohol.
- Review the safety instructions with all users annually.

## General operation

- Proceed cautiously under overhead powerlines and around power poles - contact may result in the operator suffering a severe electrical shock.
- Never allow anyone within the immediate area when operating machinery.
- Stand clear when wings are being raised or lowered.

## Transport

- Always travel at a safe speed. **NEVER EXCEED 25kph.**
- Ensure your speed is low enough for an emergency stop to be safe and secure and reduce speed prior to turns.
- Ensure safety chain is attached correctly to the towing vehicle.
- Please refer to your own country, state, provincial, county or municipality laws on the rules of transporting farm machinery on roads.
- Ensure that disc or prickle chains are engaged in chain guides and supports. Disc or prickle chain should be clear of the ground.
- Be aware of the height, length and width of the machine. Beware of obstacles and overhead powerlines.
- Use approved accessories and necessary warning devices at all times when transporting on the road.

## Hydraulics

- **NEVER** remove hydraulic hoses or ends unless the machine is in either transport position or fully extended in working position. Relieve all hydraulic pressure before disconnecting hydraulic hoses and fittings.
- Ensure all fittings and hoses are in good condition.
- Do not search for high pressure hydraulic leaks without hand and face protection. A leak can penetrate the skin, thereby requiring immediate medical attention.
- Double check that all is clear before operating hydraulics.
- Maintain proper hydraulic fluid levels and pressure.

## Maintenance and Inspection

- Good maintenance is your responsibility.
- Regular maintenance and inspection is imperative.

**Maintenance guidelines can be found in Section 5**



**If any safety decals are missing, please contact your local dealer immediately and do not use the machine**

# Section 1

## Warranty

## Warranty Policy

**The warranty for the machine will be null and void if any non-genuine Kelly part is used on the machine.**

Subject to the dealer ensuring that the machine is in correct working order and setup, in accordance with the assembly and operating manuals, at the time of delivery to the purchaser, Kelly guarantees its products against faulty workmanship and materials for twelve (12) months from date of delivery.

Ground engaging tools are warranted against faulty material and workmanship for 20 000 hectares. Replaceable cutting disc blades are warranted against faulty materials and workmanship only. All other ground engaging tools carry a 20 000 hectare wear warranty.

Kelly offers an additional 12-month warranty to the dealer if the machine is registered within 2 months from the date of delivery. Machine registrations can be completed by the purchaser or dealer on the Kelly website or the Kelly supplied warranty registration form in the operator manual.

Kelly's warranty policy does not cover incorrect assembly after handover to the purchaser, misuse, modifications, damage during transit or product that has not been maintained per the Kelly maintenance procedures outlined in the relevant product manual. Failure to properly maintain the machine or blatant misuse shall result in the warranty being null and void.

All warranty claims from the purchaser must be made through the dealer, who in turn, will make a reciprocal claim on Kelly. Kelly will reimburse the dealer for any claims it approves who, in turn, will reimburse the purchaser.

Kelly reserves the right to request written, photographic or video documentation of the actual defect or failure prior to any warranty authorisation. All warranty queries and requests for authorisation can be directed to [warranty@kellytillage.com](mailto:warranty@kellytillage.com)

Any warranty repair, service or modification to products must be performed by an authorised Kelly repairer and pre-approved by Kelly in writing prior to any work being carried out.

Kelly will issue an "Authorised Returns" notice for any faulty parts to be returned at the request of the company. Failure to do so on request may result in the claim being declined.

Any claim for warranty, labour or parts must be completed on the prescribed warranty claim form found on the Kelly website.

Warranty claims are to be lodged within 30 days of completion of work. If further information is requested on the claim from the Market Liaison Officer, you have 30 days to provide the information. If you fail to adhere with the above instructions the warranty claim may be declined.

Upon completion and approval of this claim the dealer will receive a credit to their account.



# Kelly Product Registration

Register within 2 months of purchasing the machine to receive an additional 12 months warranty

This form must be completed and returned to Kelly, either online, emailed or posted in order to receive the additional 12 months warranty

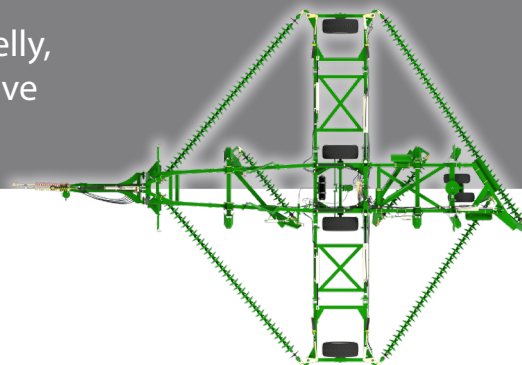

**Please return the registration and survey to :**

**Fill out online**

<http://www.kellytillage.com>

**Mail to**

Kelly  
PO Box 100, Booleroo Centre SA 5482 Australia

**Email**

[sales@kellytillage.com](mailto:sales@kellytillage.com)

**Purchaser/ owner**

Name \_\_\_\_\_

Address \_\_\_\_\_

Email address \_\_\_\_\_

Contact number \_\_\_\_\_

**Purchasing Details**

Place of purchase \_\_\_\_\_ Date of purchase \_\_\_\_\_

Model purchase \_\_\_\_\_ Serial number \_\_\_\_\_

**Occupation**

Farmer  Customer operator  Other \_\_\_\_\_

**What brought Kelly products to your attention ?**

Field Day  Friend/ neighbour  Local Dealer  Website  
 Dealer  Family  Radio  Referral Source \_\_\_\_\_  
 Demonstration \_\_\_\_\_  Magazine/ newspaper \_\_\_\_\_

**On a scale of 1 to 10 (10 being highest) how likely are you to recommend us to friends and family ?**

|   |   |   |   |   |   |   |   |   |    |
|---|---|---|---|---|---|---|---|---|----|
| 1 | 2 | 3 | 4 | 5 | 6 | 7 | 8 | 9 | 10 |
|---|---|---|---|---|---|---|---|---|----|

**If you scored 8 or below then what must we do to become a 10 in your opinion?**

\_\_\_\_\_

\_\_\_\_\_

**If you scored 9 or above then please tell us why you gave us this score?**

\_\_\_\_\_

\_\_\_\_\_

**Satisfaction with dealer/ agent**

Was the machine pre-delivered satisfactorily ?  Yes  No \_\_\_\_\_

Were agents well informed about the product ?  Yes  No \_\_\_\_\_

Would you recommend the agent to other farmers ?  Yes  No \_\_\_\_\_

## Thank you for choosing a 9m Kelly Tillage System

We trust that you find the following manual clear and easy to follow. However, should you require additional customer support or assistance, please do not hesitate to contact us.

Spare parts can be purchased, as required, through your local dealer or by contacting Kelly.

Kelly welcomes feedback. Should you have any difficulties that you wish to raise, suggestions for improvement or modifications that you feel would enhance our products, we look forward to hearing from you.

### Contact Information

**PO Box 100**

**Booleroo Centre SA 5482**

**Phone:** + 61 8 8667 2253

**Email:** [sales@kellytillage.com](mailto:sales@kellytillage.com)

**Spare Parts:** [parts@kellytillage.com](mailto:parts@kellytillage.com)

**Website:** [www.kellytillage.com](http://www.kellytillage.com)

# Section 2

## Machine Operation

## Before operation

- Carefully study and understand this manual.
- Do not wear loose fitting clothing that may catch in moving parts.
- Always wear protective clothing and footwear.
- Be sure that there are no tools lying in or on the equipment.
- Do not use the machine until you are sure that the area is clear, particularly of children or animals.
- If this machine is being used in a dry area, or in the presence of combustibles, care should be taken to prevent fires and fire fighting equipment should be readily available.
- Familiarise yourself and other operators with the machine's operation before using.

## Pre-operation Checklist

1. All wheel nuts, bolts and nuts are tightened to the correct torque setting
2. Split pins are in place & split
3. Stickers and warning signs are in place
4. Hydraulic fittings are tight and have no leaks
5. Chains are adjusted so that all springs are compressed to 330mm
6. Fold machine to ensure chains engage transport rests
7. Check swivel bearings are not seized and still turning freely

## Machine set up prior to operating

- Set brake tension on castor wheels to suit ground conditions.
- Compress spring to approx 55-63mm.  
*(It is usually not necessary to constantly adjust the spring tension. A median setting that accommodates both field and highway use is practical. Make further adjustment if castor wheels oscillate during highway use).*

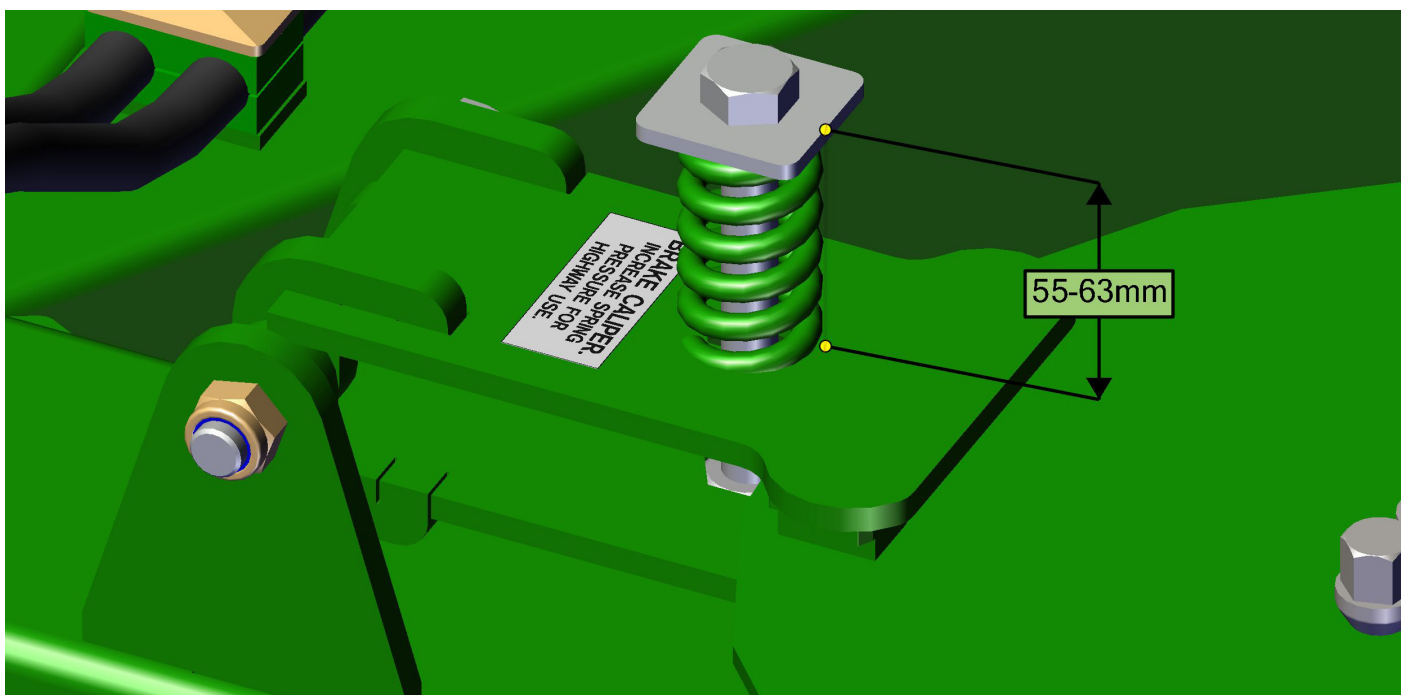

## Park Brake

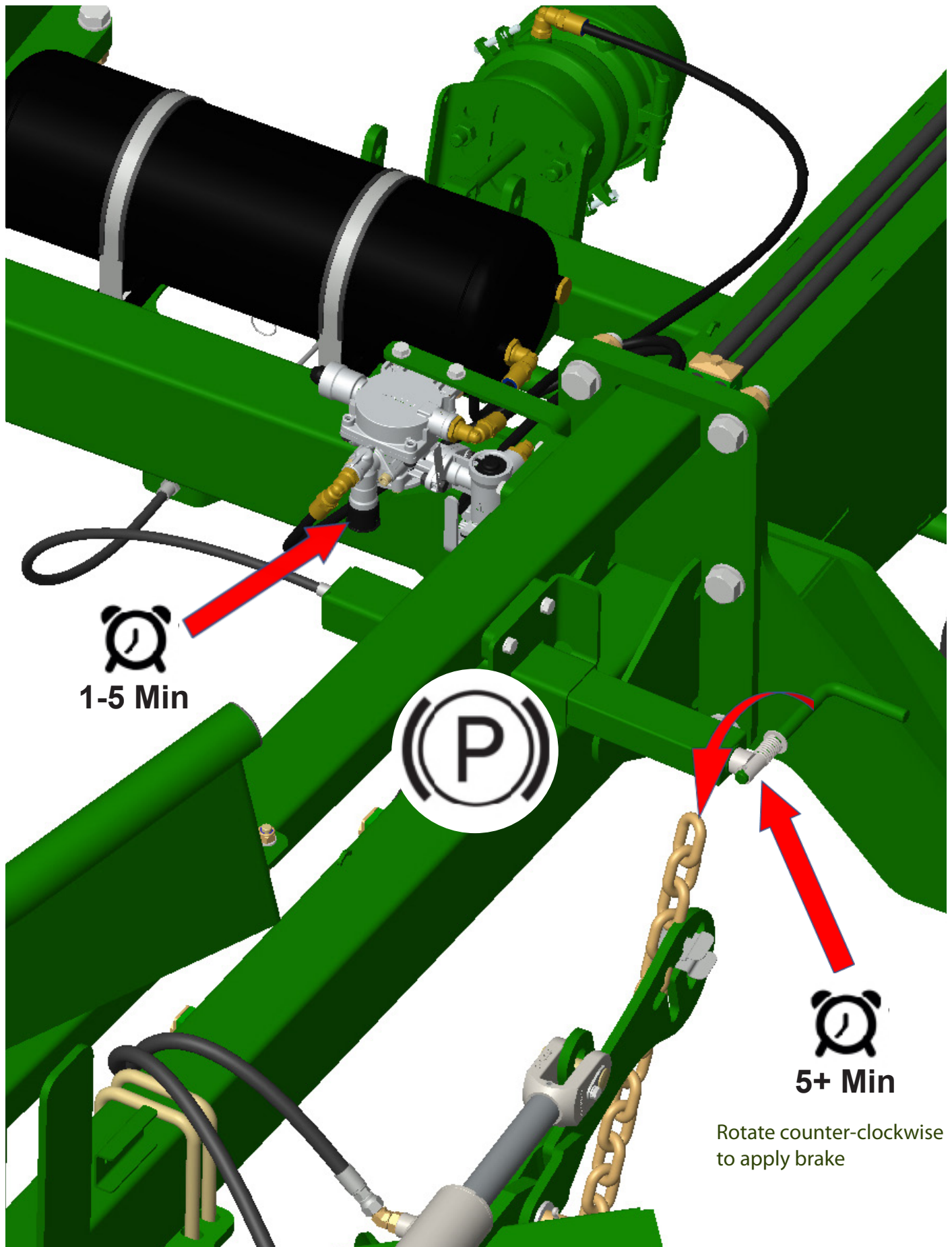

Rotate counter-clockwise  
to apply brake

## Brake Setup

Full load for chain configuration (front/ rear)

(CL2/CL2, CL2/CL1, CL2/SD49, CL1/CL1, CL1/W36, CL1/SD49 SD49/SD49, R300/R300)

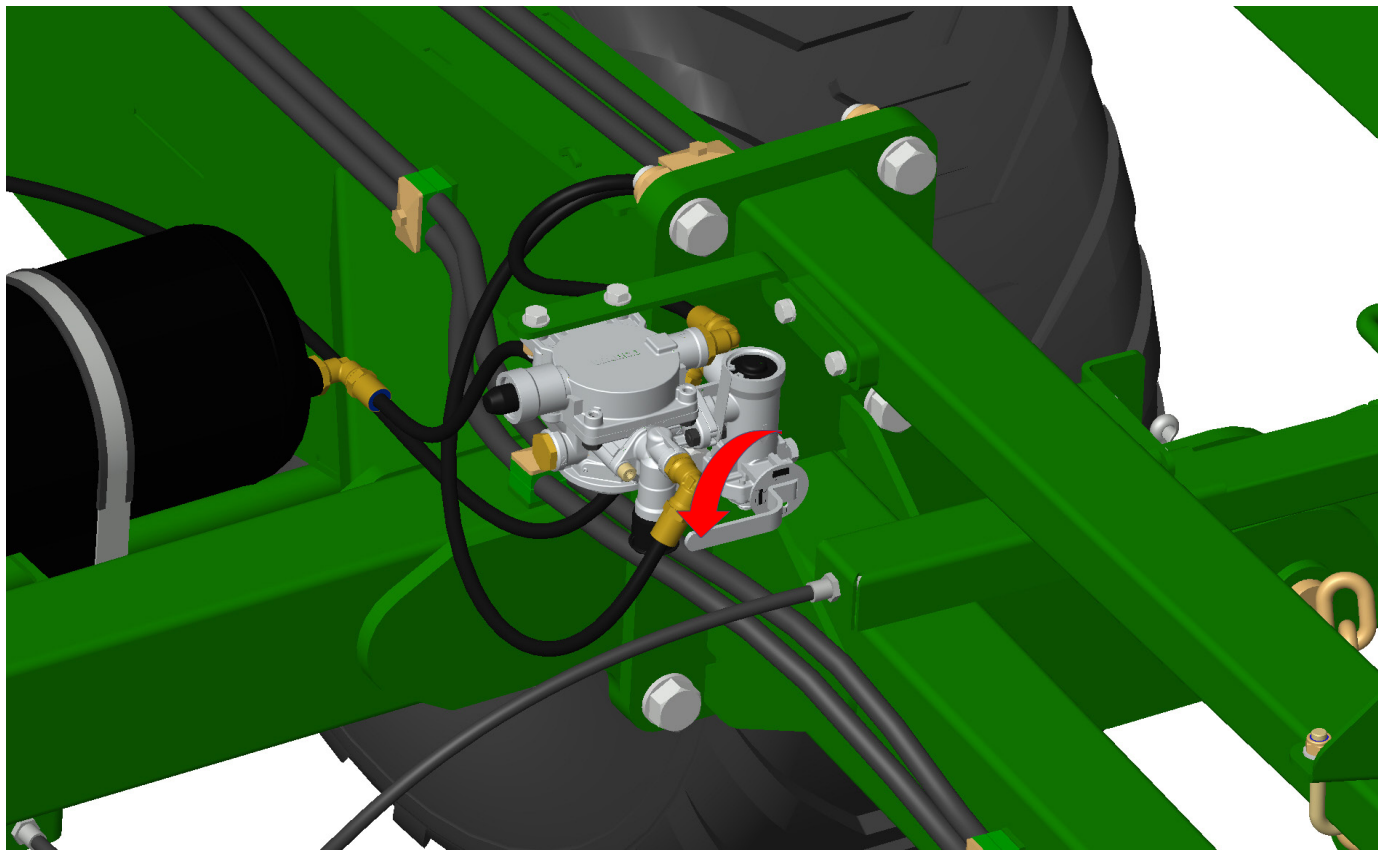

Half load for chain configuration (front/ rear)

(W36/W36, Prickle Chain/ Prickle Chain)

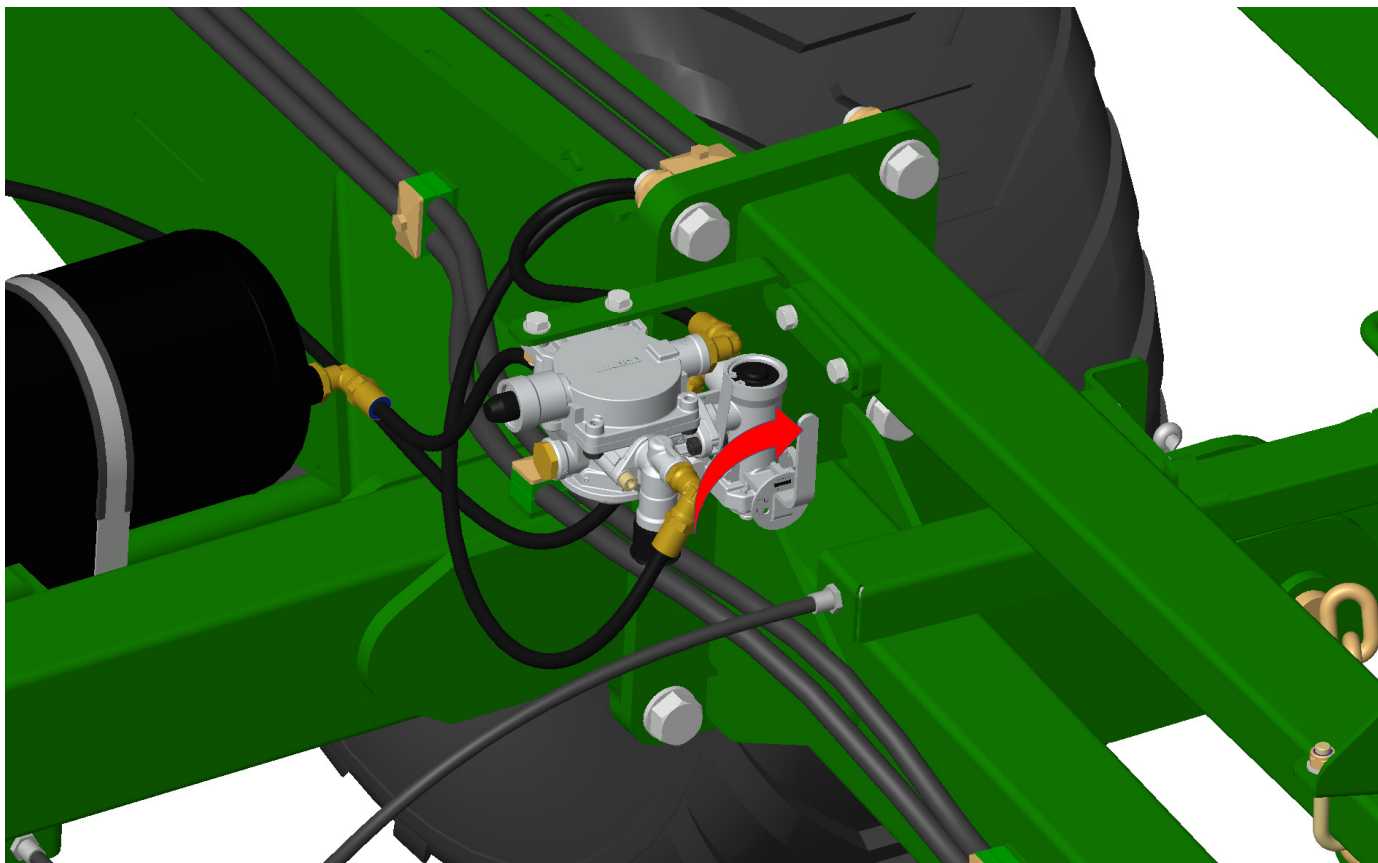

## Basic Operation

### Important Locations



Chain carriers/transport rests

Height adjusting chains and Slotted plates

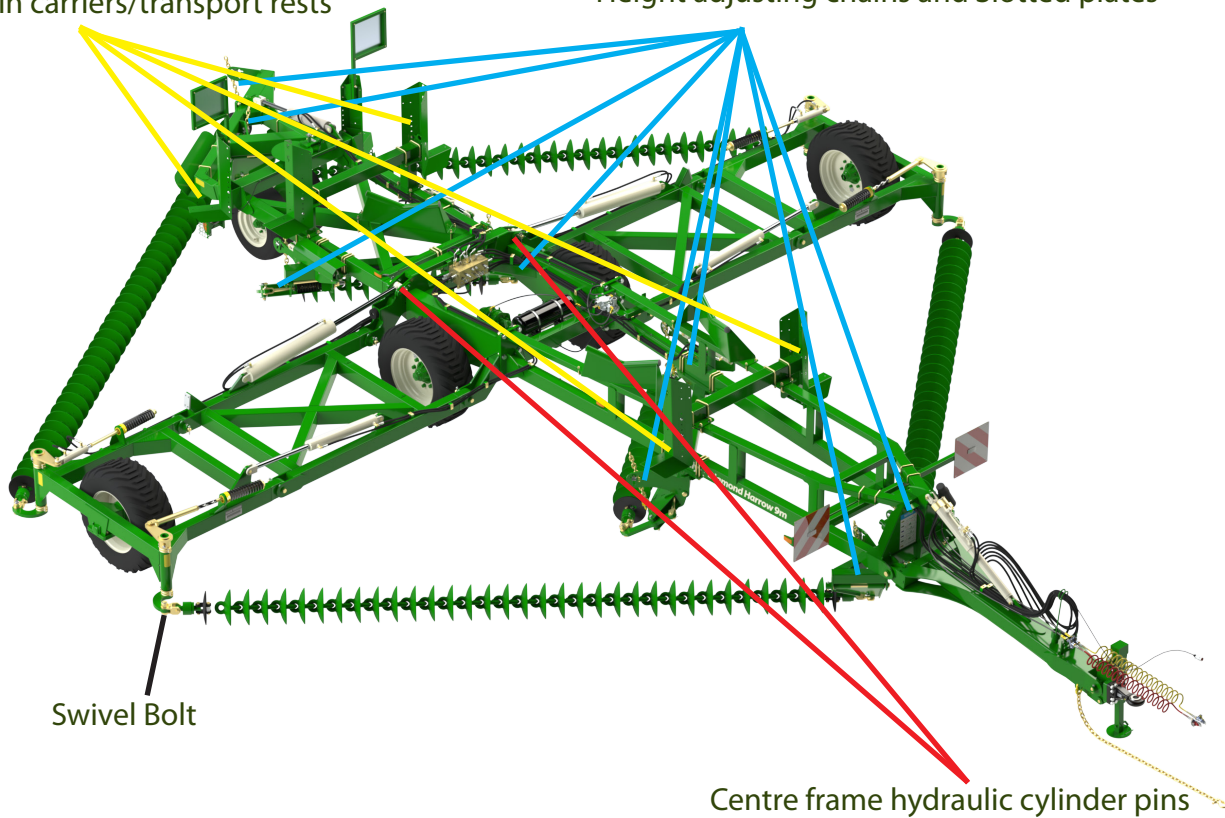

## Unfolding

### Unfolding:

1. Remove transport safety stop from drawbar cylinder shaft. Once removed, store in holder on Front A Frame.

*Ensure front cylinder depth stop plates are fully engaged on cylinder shaft.*

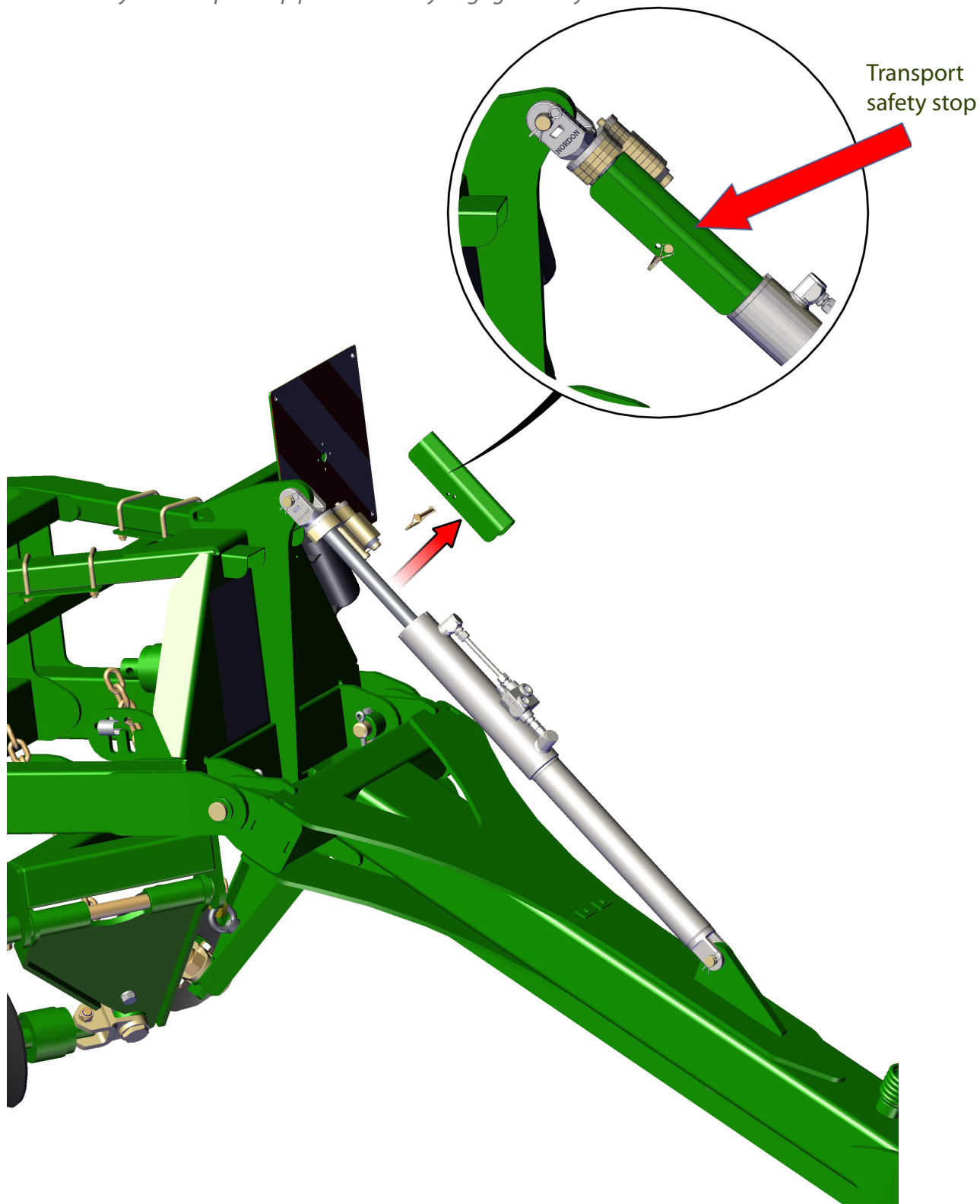

2. Walk around and inspect the machine.

- a. Check that chains are not hooked on framework.
- b. Check swivel bolts at end of each chain are in place and not broken.
- c. Check that height adjusting chain has not fallen out of slotted plate during transport.



## Unfolding

3. Follow steps 4-6 on folding/unfolding decal.
  - a. Lower front A Frame to working height.

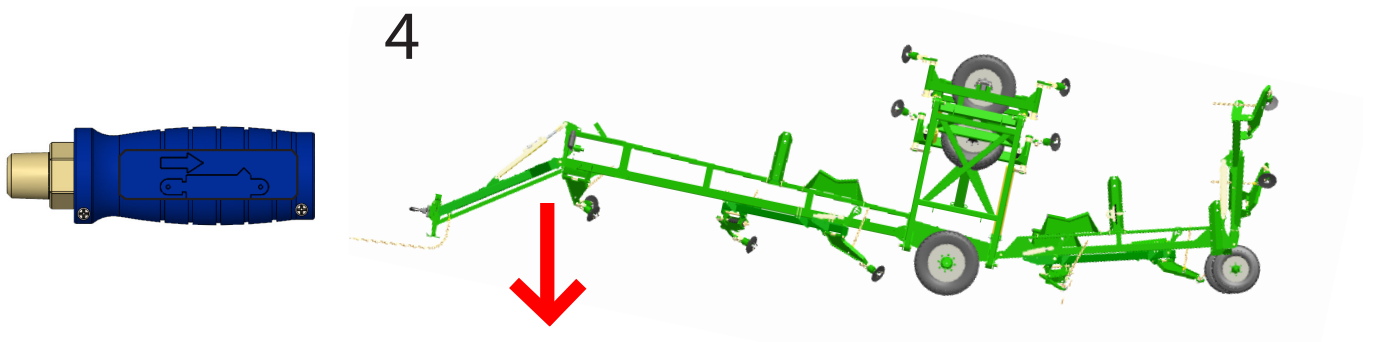

- b. Unfold wings, holding the hydraulic lever until the centre frame hydraulic cylinder pins have centered in their slots.

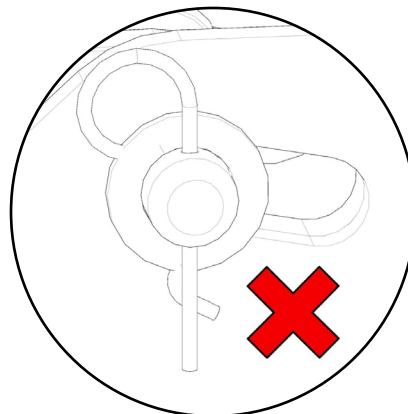
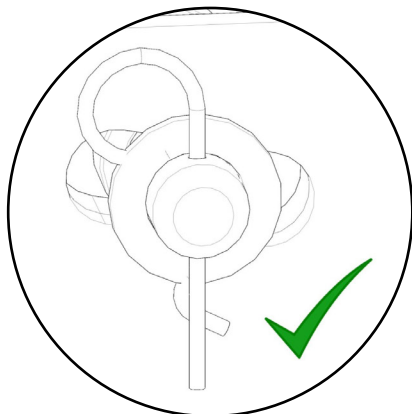
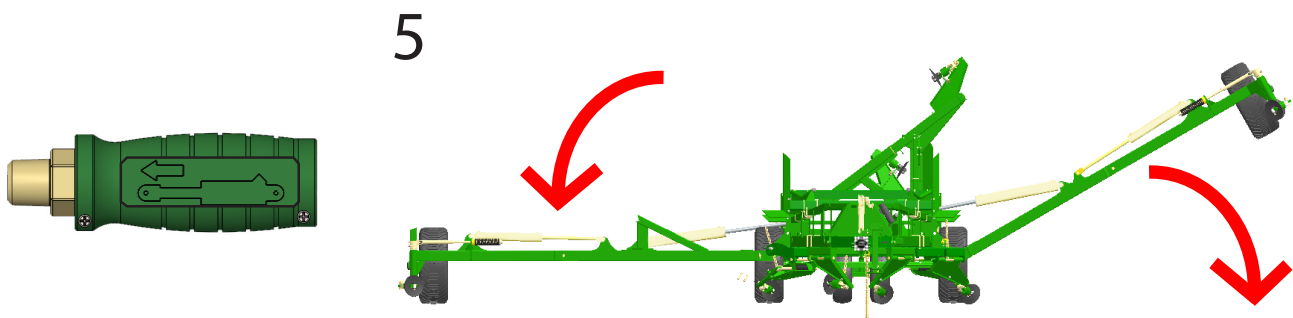

## Unfolding

- c. Lower rear tail by holding hydraulic lever until tail and modules are completely lowered to working position and the wing de-tensioning cylinders are fully retracted, tensioning the chain.

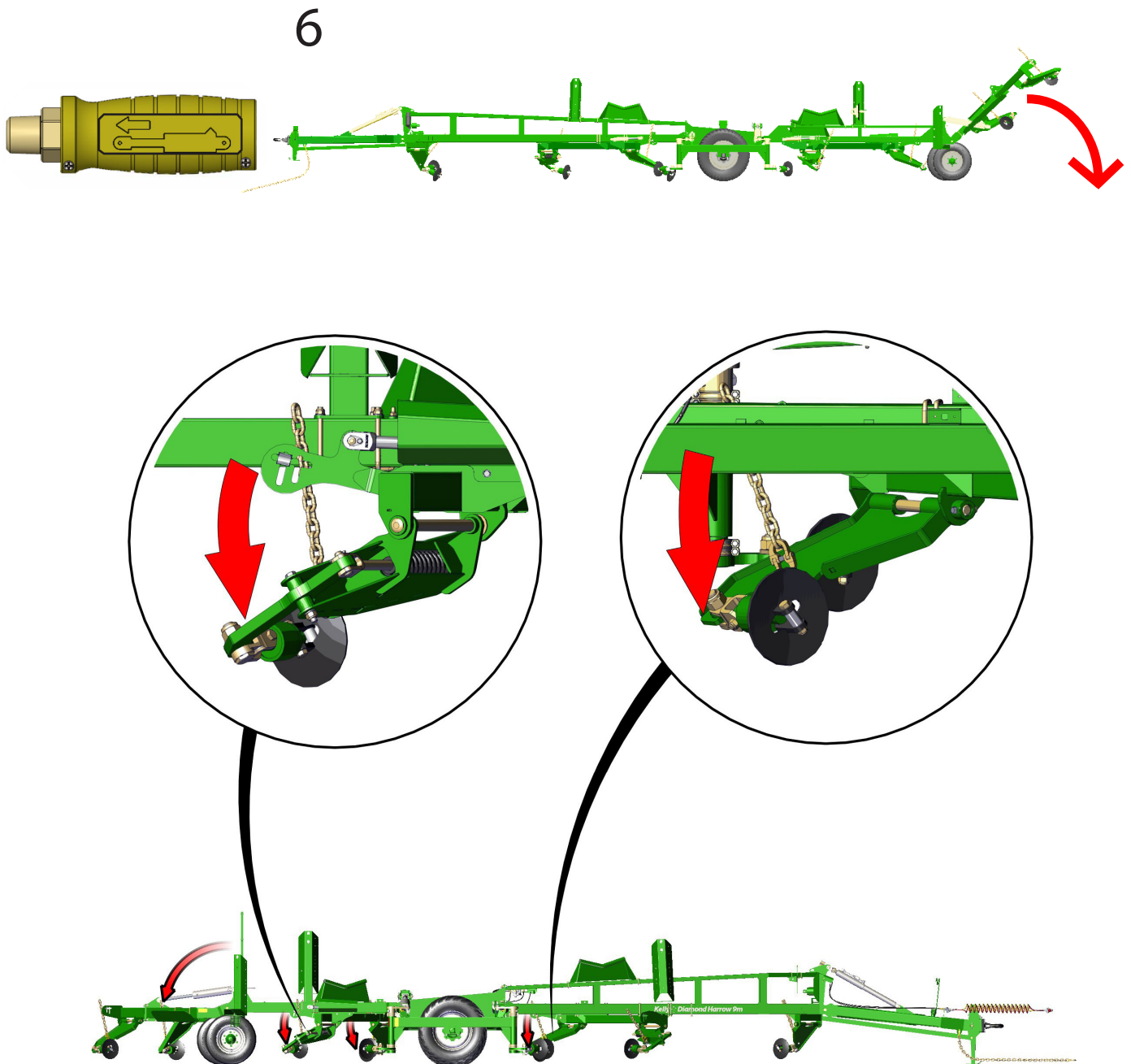

4. Walk around machine and check that all chain links are straight and that working height of all swivels are correct for field conditions. Adjust if necessary. Refer to Page 30 for Chain Height Adjustment.
5. Move off with all chains in working position. If necessary it is acceptable to raise Front A Frame and drawbar to transport height. This will lift the front chains off the ground and reduce the load on the tractor. Lower the front A Frame once operating speed is reached.

# Unfolding

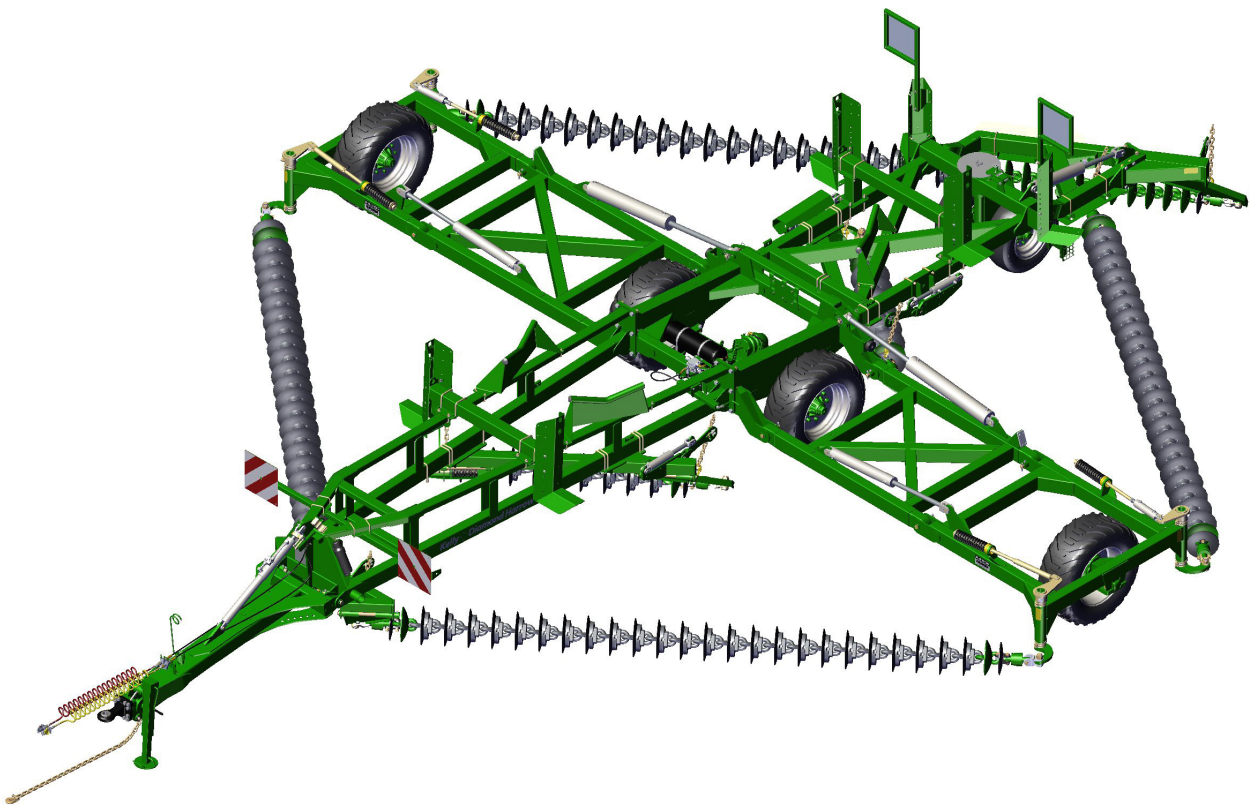

## Folding

### Folding:

1. Follow steps 1-3 on folding/unfolding decal.

a. Lower the Front A Frame to working height. It's important to ensure that all chains locate correctly in their transport rests.

b. Raise the Rear Tail and Modules by holding the hydraulic lever until they come to a complete stop.

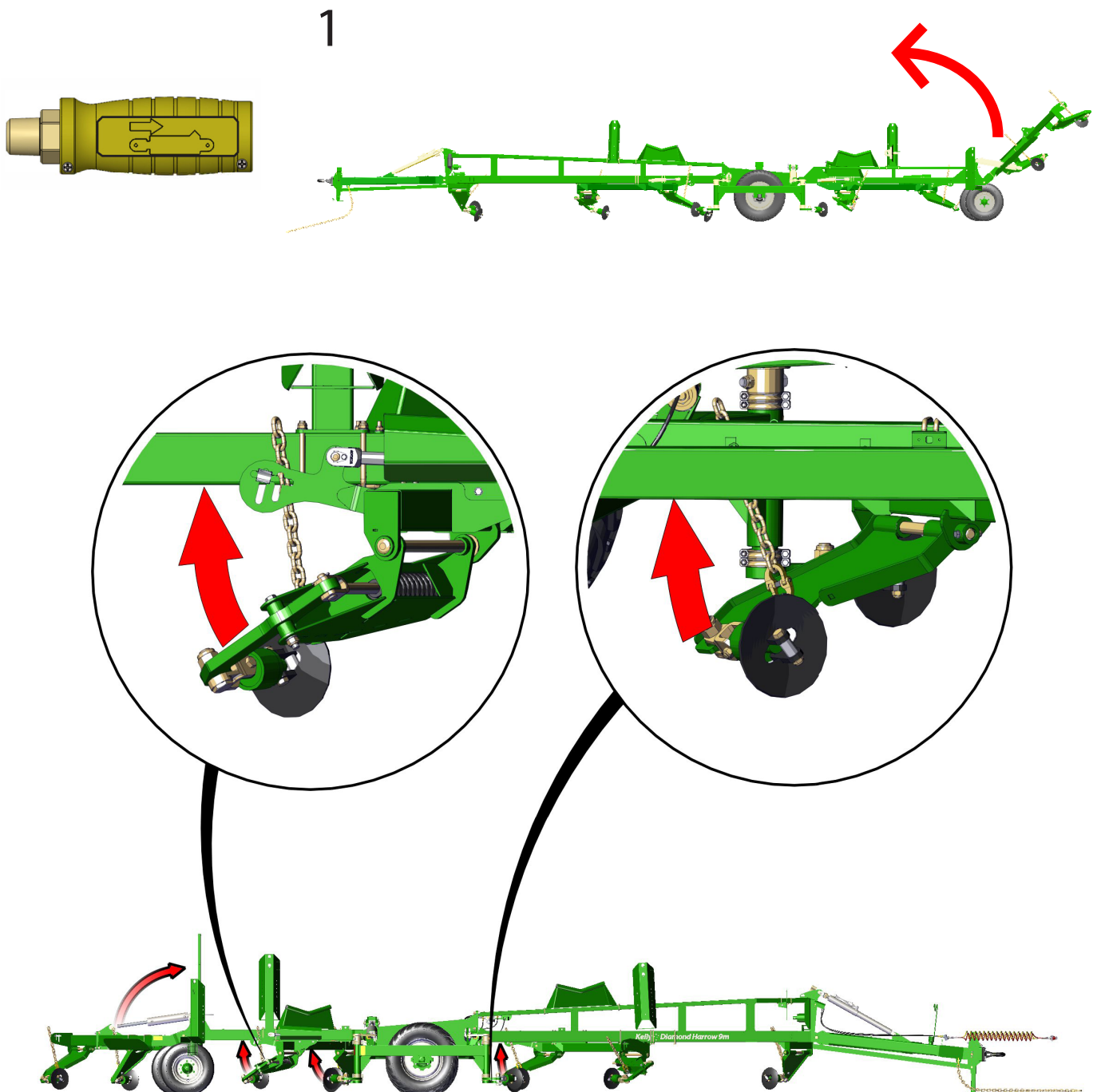

## Folding

c. Fold the wings. They should move as follows:

- Main centre cylinders will retract (one or both) until the wings stand vertically
- The left outer wing then the right outer wing will fold down

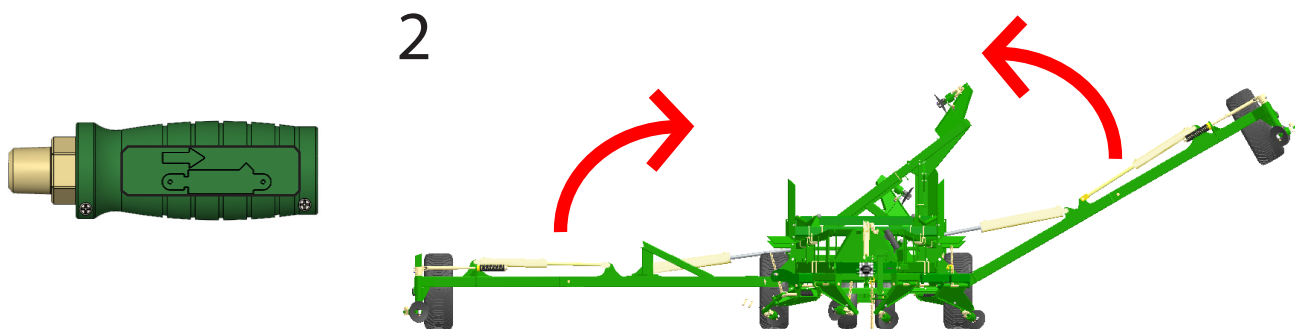

d. Raise Front A Frame to transport height.

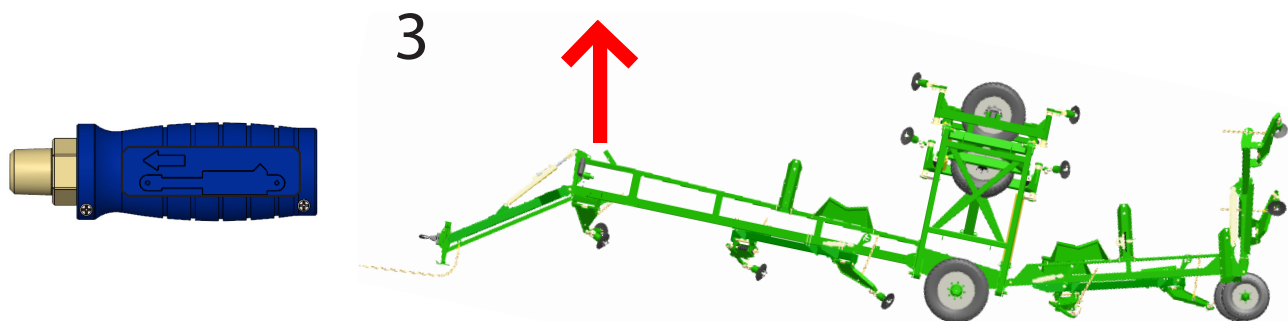

2. Walk around and check that chains have located correctly in transport rests.

3. Install Transport safety stop on drawbar cylinder shaft.

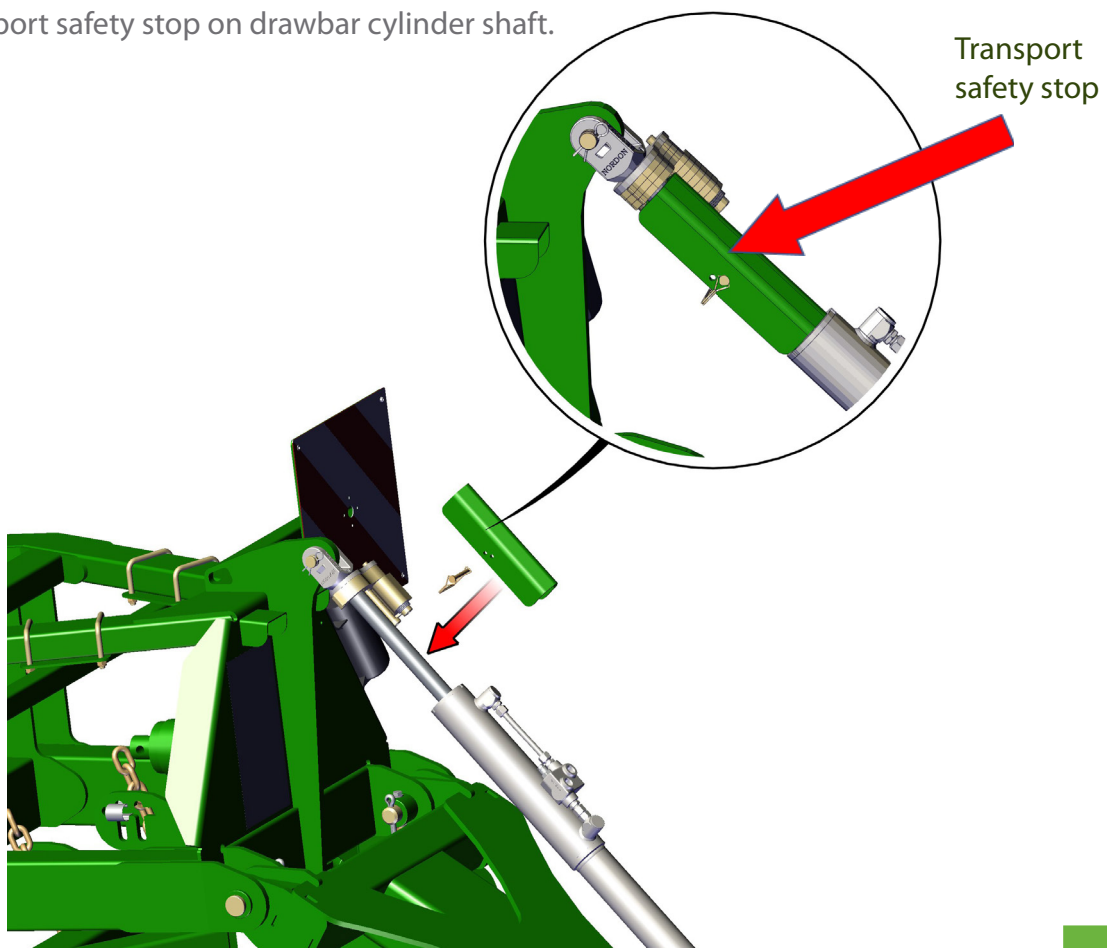

## Folding

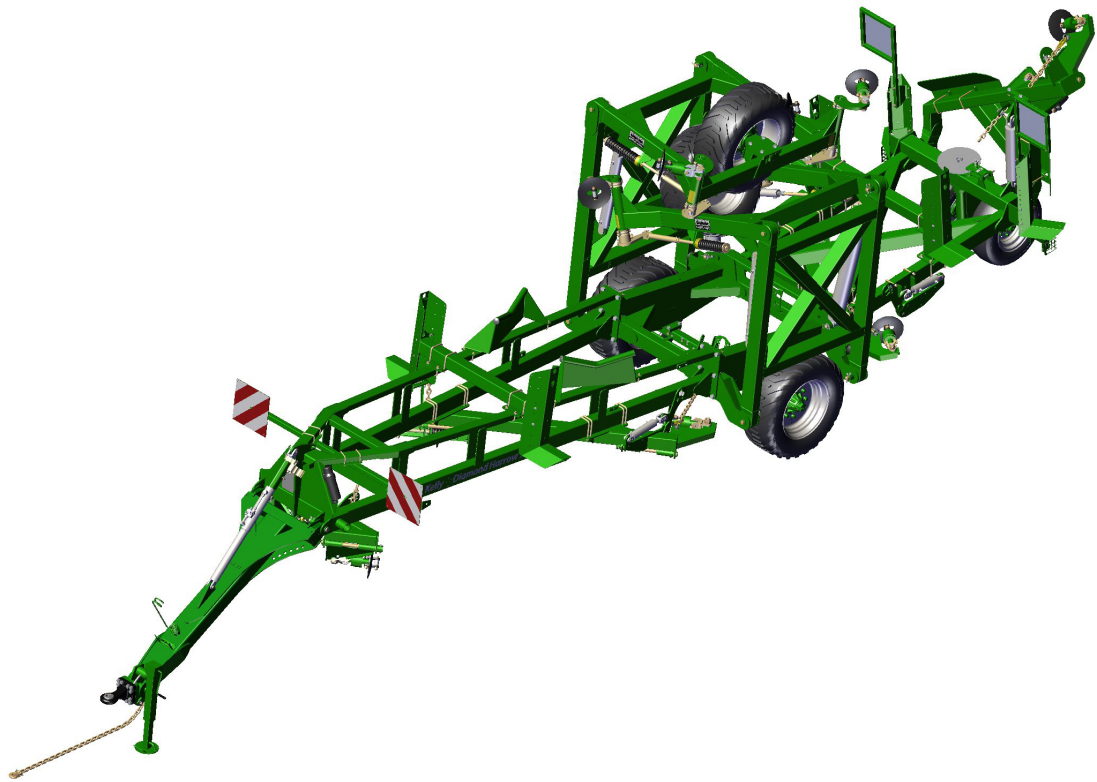

# Section 3

Chain Operation & Correct  
Setup

## Operation

### Importance of Chain Tension

#### Operational

It is imperative that the correct adjustment be maintained. Only through correct adjustment can a smooth and level finish be achieved in field working.

Loose chains lead to :

- Uneven performance across the width of the machine
- Uneven weed control
- Unsatisfactory incorporation
- Ineffective levelling
- Accelerated or premature chain link wear
- Chains failing to engage with transport locators when folded
- Machine damage when folding or unfolding
- Uneven field surface with ridges and furrows being created. The leading 1/3rd of a loose chain is much more aggressive than the trailing 1/3rd and the centre. This will mean that the middle of the machine's front pair of chains will aggressively move soil outwards. The machine's rear pair of chains, if loose, have their aggressive 1/3rd near the wing extremity. It follows then that as the front discs push soil outwards, the least aggressive portion of the rear chain follows them and does not balance the soil movement. This is exacerbated at the wings, effectively creating a broad ridge about halfway out each wing. It won't be evident in one pass, but is possible if care is not taken over time.

**A correctly adjusted machine will not have this problem.**



## Chain Tension - Modules

- Loosen the lock nut on the module tension rod.
- Tighten the adjusting nut clockwise until the outer face of the spring retaining washer is flushed with the body of the module tensioning unit.
- Retighten the lock nut.
- After setting the tension assemblies to have the recommended thread showing (less than 200mm), move out to the wings of the machine and use the PCHTA adjusters to tension the gang of discs.



End of tension assembly body

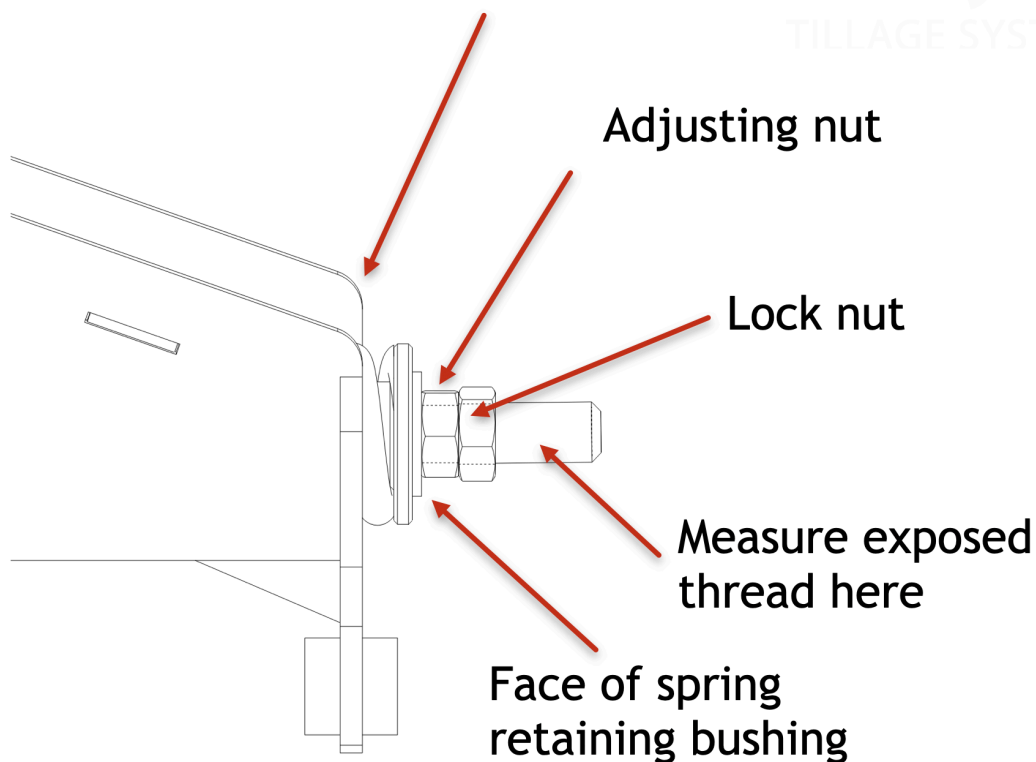

## Chain Tension - Modules

1.

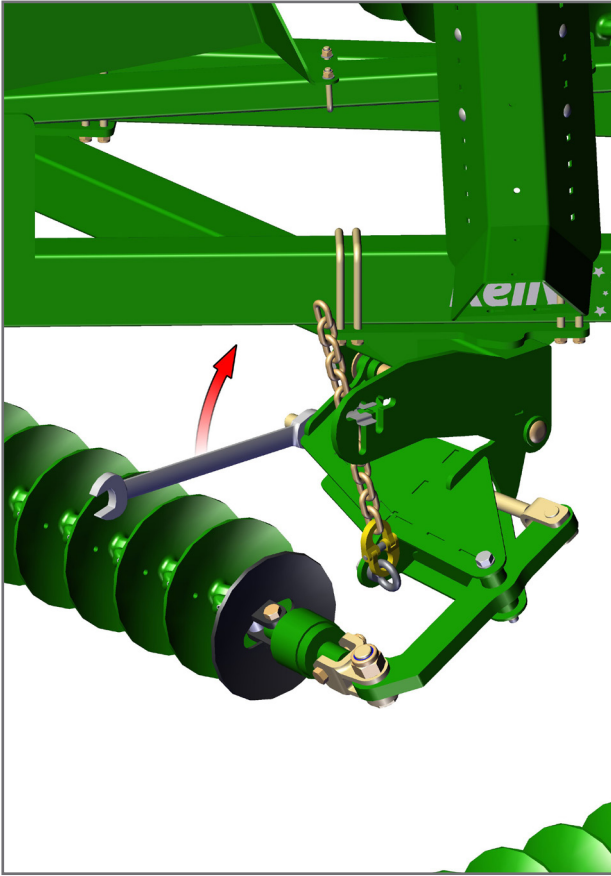

2.

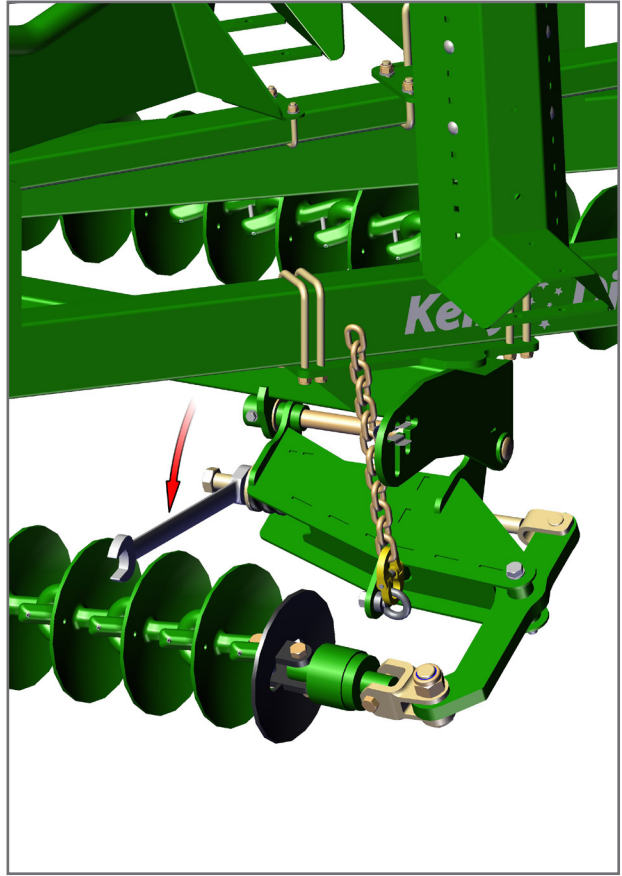

3.

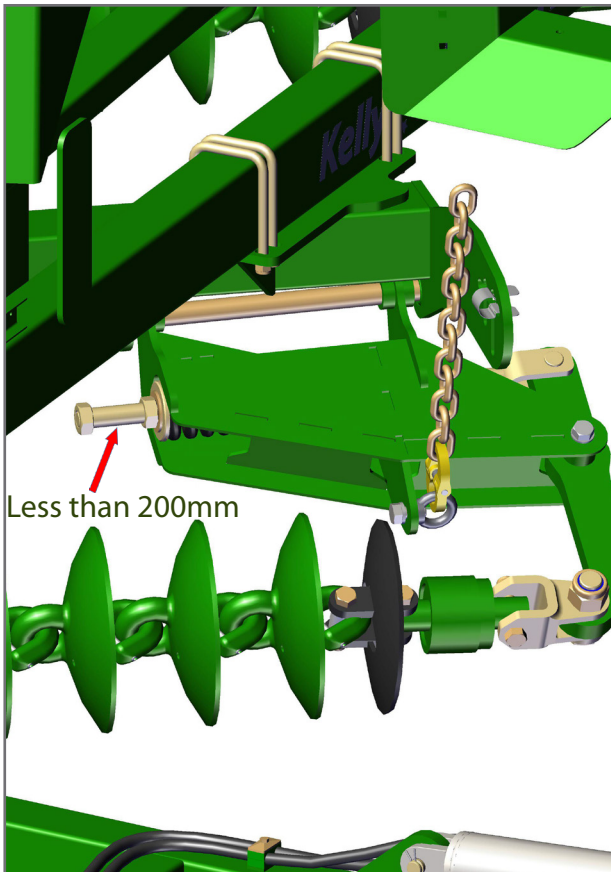

4.



## Chain Tension - Front Chains

- Use the spanner supplied to loosen the lock nut adjacent to the tensioner assembly body.
- Turn the module tension rod clockwise to compress the coil spring to 330mm. Correct tension is achieved when spring retains its set length when operator rolls the chain fore and aft on the ground.
- Retighten the lock nut.
- When less than 25mm of thread remains visible on the adjustor bolt then a link must be removed from the chain.

1.

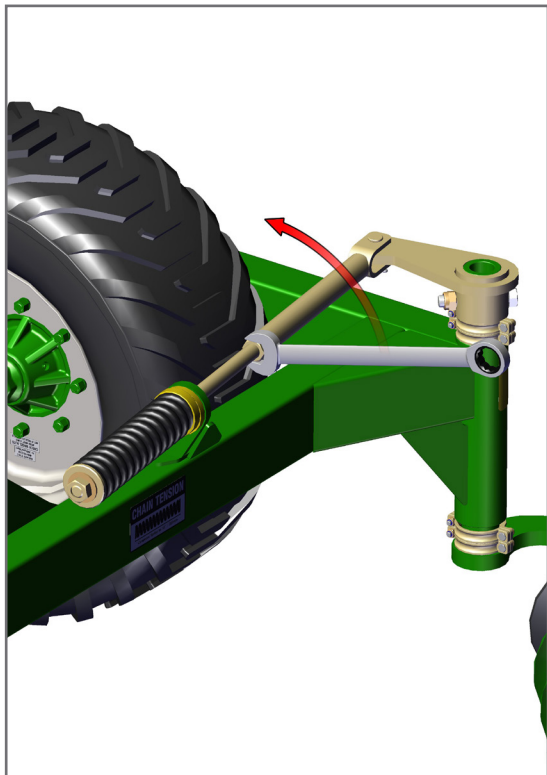

2.

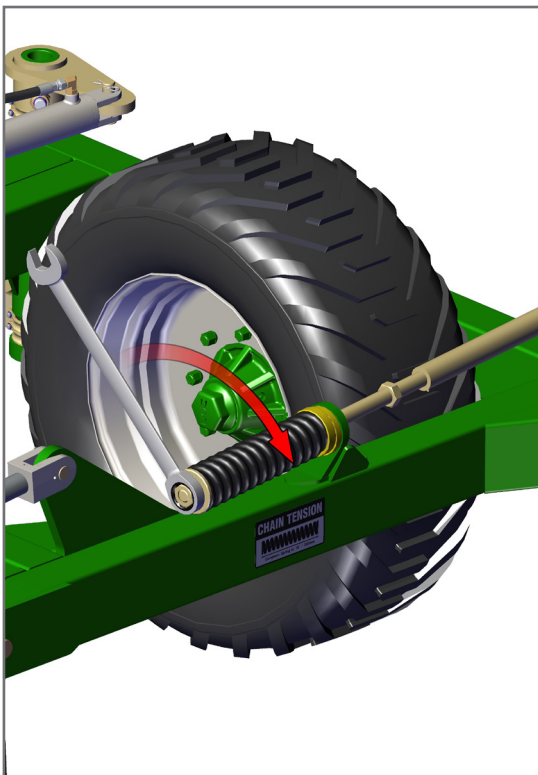

3.

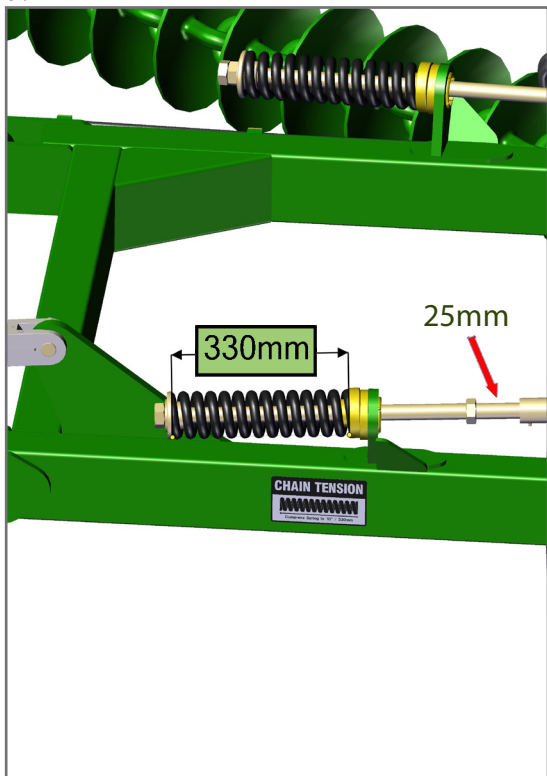

4.

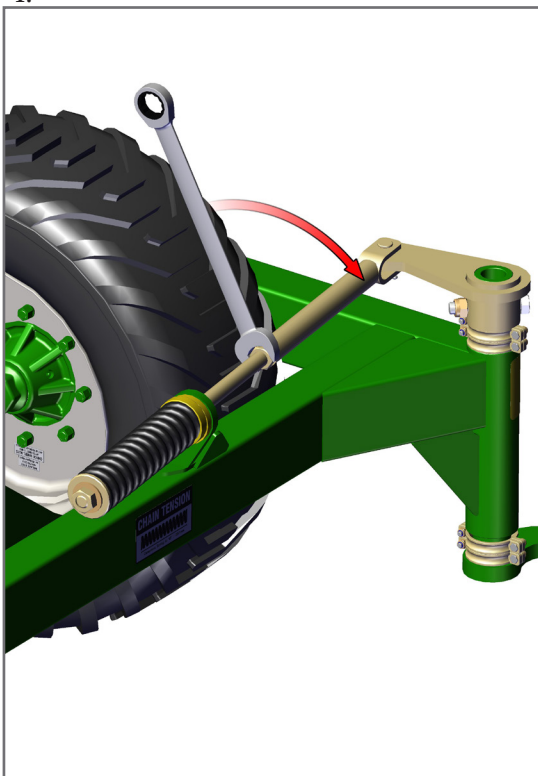

## Chain Tension - Rear Chains with Hydraulic De-Tensioning

1.

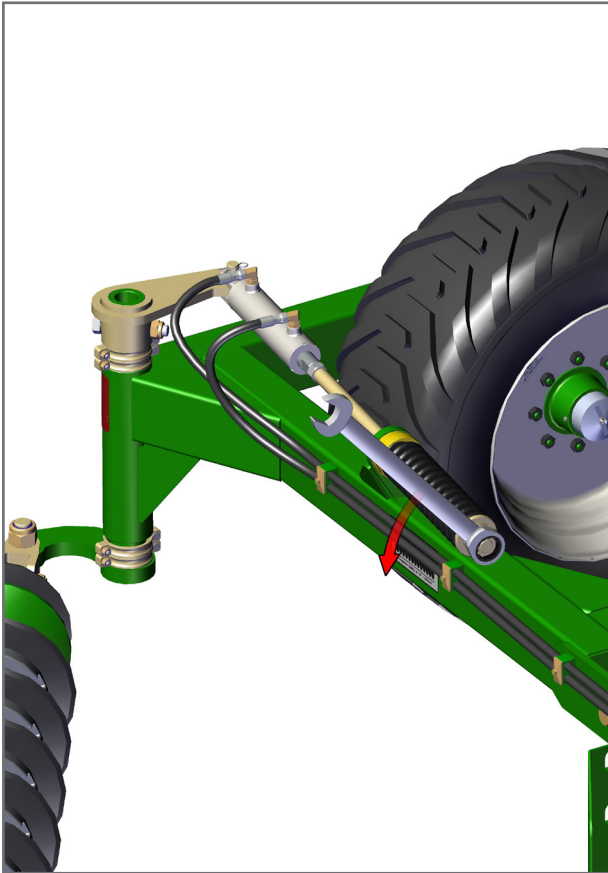

2.

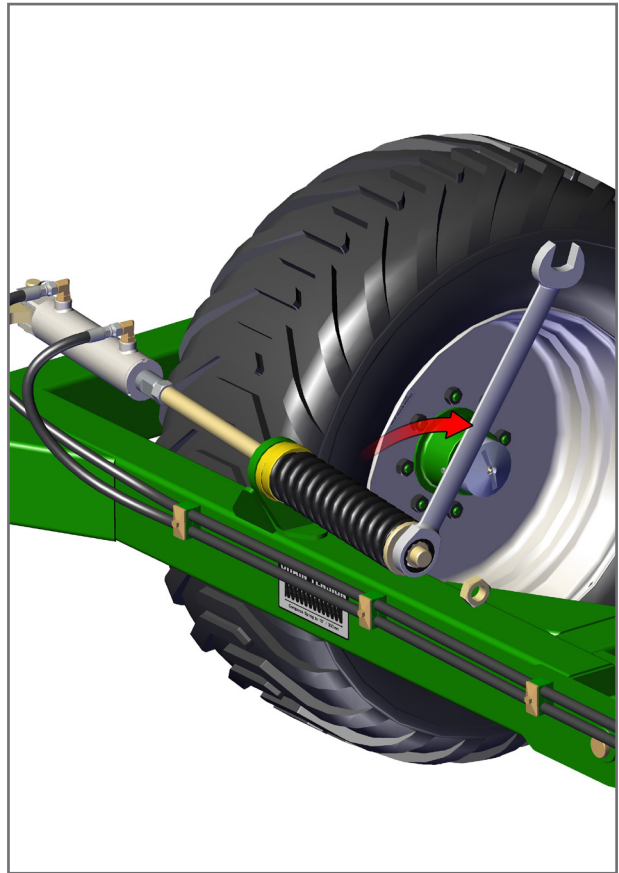

3.

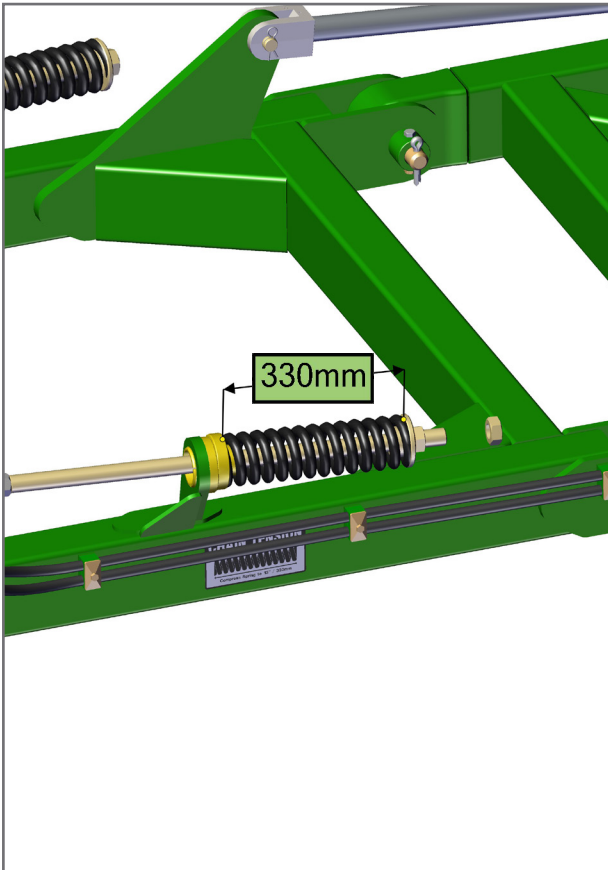

4.

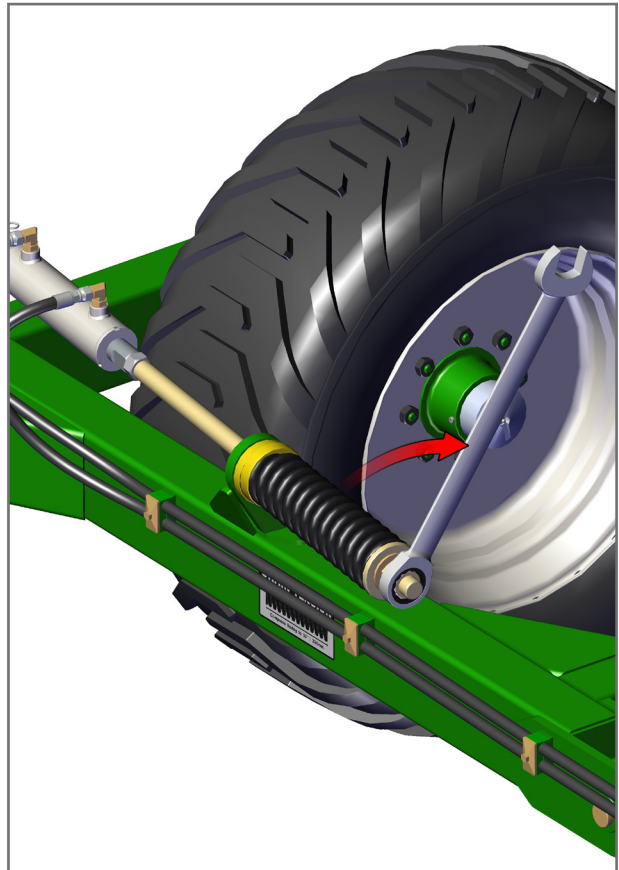

## Operation

### Chain Curve

Correct chain tension will ensure that the entire length of discs will roll as one. This minimises the movement between each link. If a chain is not adjusted and runs loose, each link acts as a universal joint as the curved chain rolls along. The wear rate between each link is greatly accelerated and can lead to premature failure. The chain should not wear out before the discs are worn down.

**ONLY POOR ADJUSTMENT CAUSES PREMATURE WEAR**

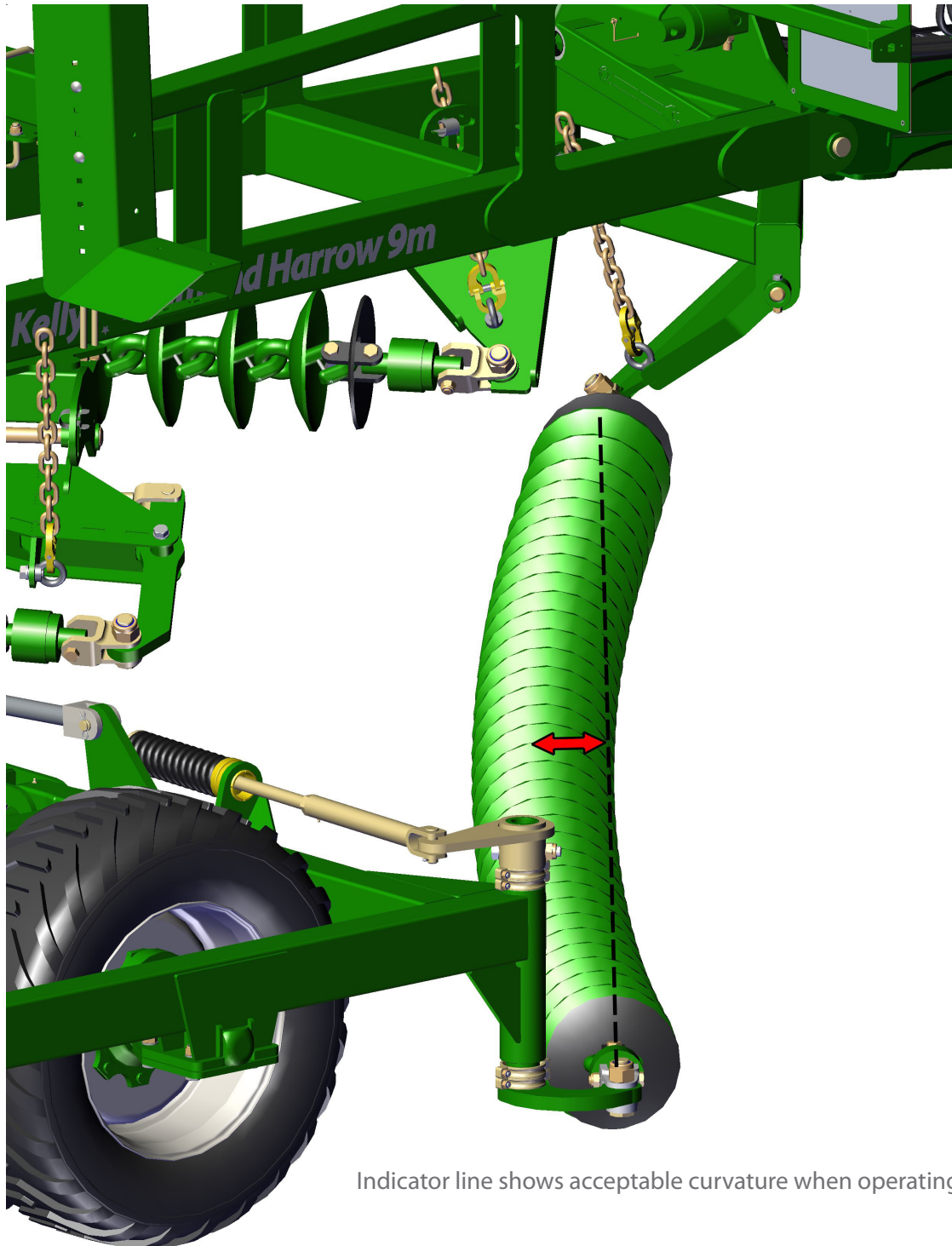

Indicator line shows acceptable curvature when operating.

## Operation

### Correct Chain Height Adjustment

To adjust the swivel height at the wings, relocate one of the spacers either above or below the fixed mounting tube. Each Dropleg has four pairs of 25mm cast spacers. The most common set up is to have two pairs of cast spacers on the bottom and two pairs of cast spacers on the top. Below is the process to adjust the Dropleg height.

1. Loosen chain tension completely
2. Undo 2 x M10 bolts from corresponding spacer set and take the two halves off of the drop leg tube
3. Replace it in the selected position after raising or lowering the drop leg
4. Reinstall the M10 bolts and re-tension the chain

It is possible to install all spacers either above or below the mounting tube giving a maximum of 100mm of adjustment. 1.

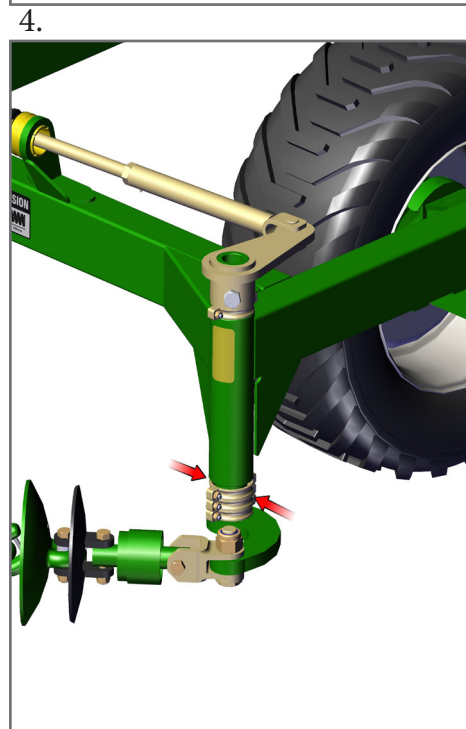
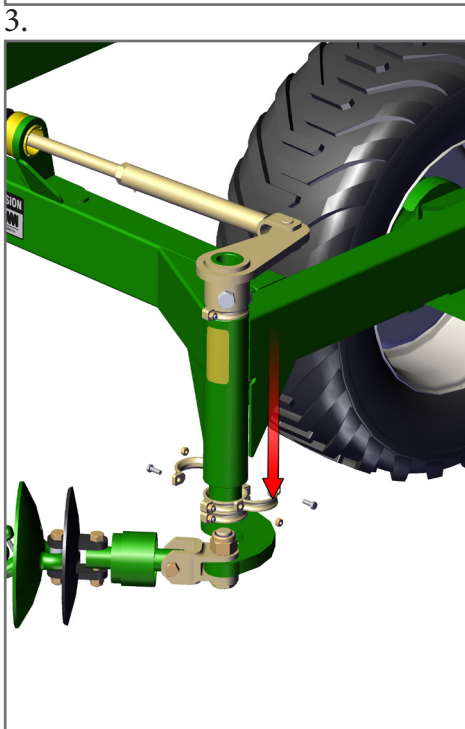
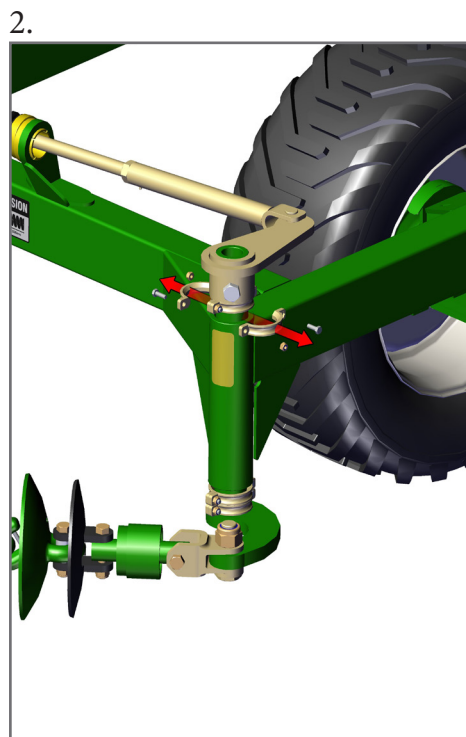
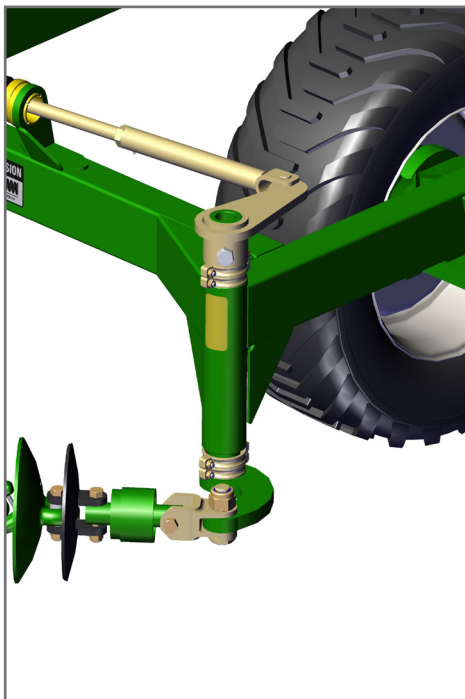

## Operation

### Height Adjustment for Rear Chain Wing Mounts

To adjust the swivel height at the wings on the rear chains follow steps 1-4 as above. From factory, the swivel height is set with two spacers above the fixed mounting tube.

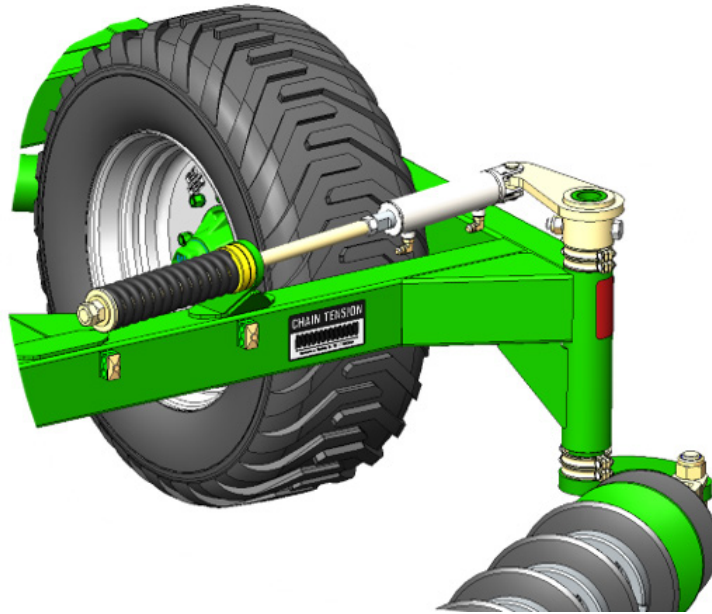

In the unlikely event that your conditions require the swivels to be set as low a possible, you will need to reorient the cylinder such that the hydraulic ports point upward.

(Please note that if all the cast spacers are used on the bottom & the cylinder orientation is not flipped, then the hydraulic ports could clash with the framework as illustrated on the left, below)

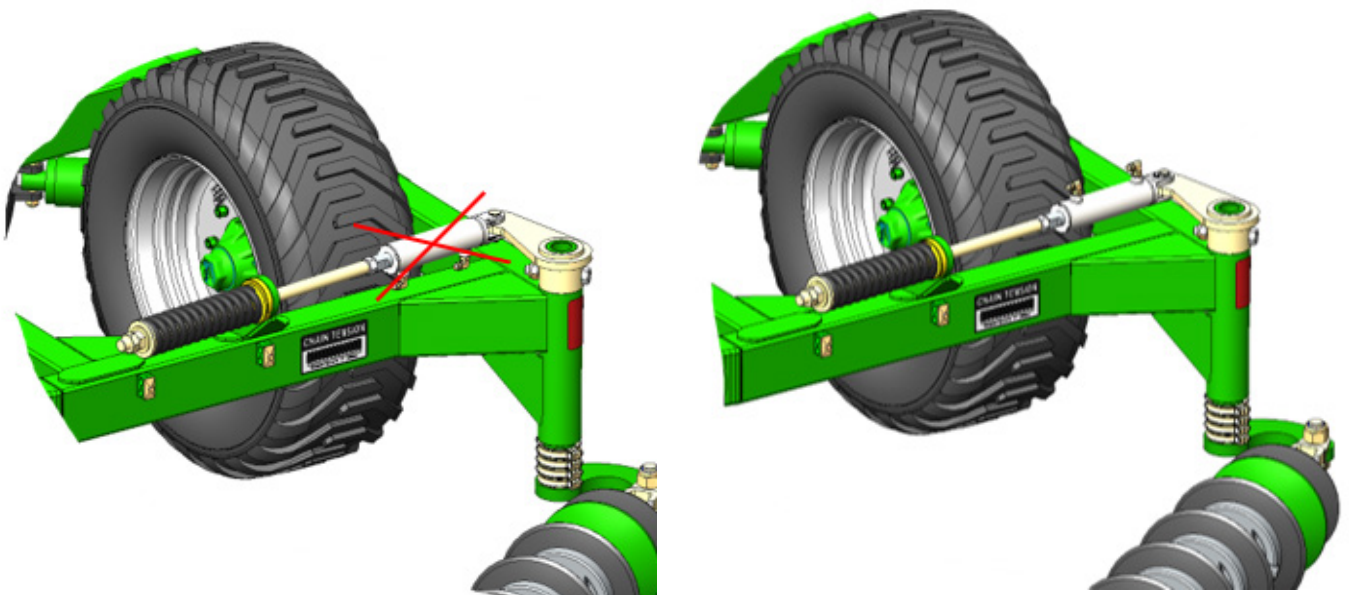

## Chain Mount Plate Height Adjustment

1. Use tractor hydraulics to raise the module chain or chain mount plate that requires adjustment. Position a suitable block or stand to support the arm. Using the tractor hydraulics, lower the machine until the height adjusting chains are loose.
2. Remove spring retaining clip. Slide chain up to the top of the slot in lifting arm to pass the chain through the cross at top of plate.
3. Slide chain back down to the bottom when the desired position is reached. To achieve "1 link" of adjustment, lift chain to the top of the slot, pass 1 link through the slot and rotate 90 degrees to allow the next link in the adjusting chain to lower into the same slot. To achieve " $\frac{1}{2}$  link" of adjustment lift the chain to the top of the slot and slide chain horizontally and lower the same link into the second slot. This will raise or lower the chain mount plate by half a link depending on which slot the chain started in. Any excess chain can be fed back through the second slot.
4. Install retaining clip. Remove stand.

1.

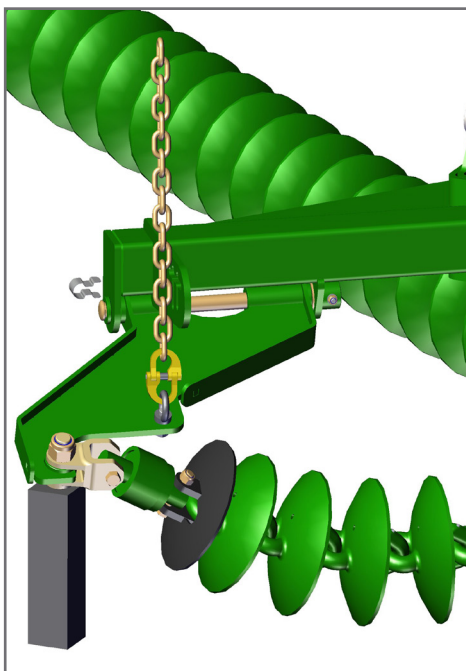

2.



3.



4.





## Operation

### Front A Frame height adjustment

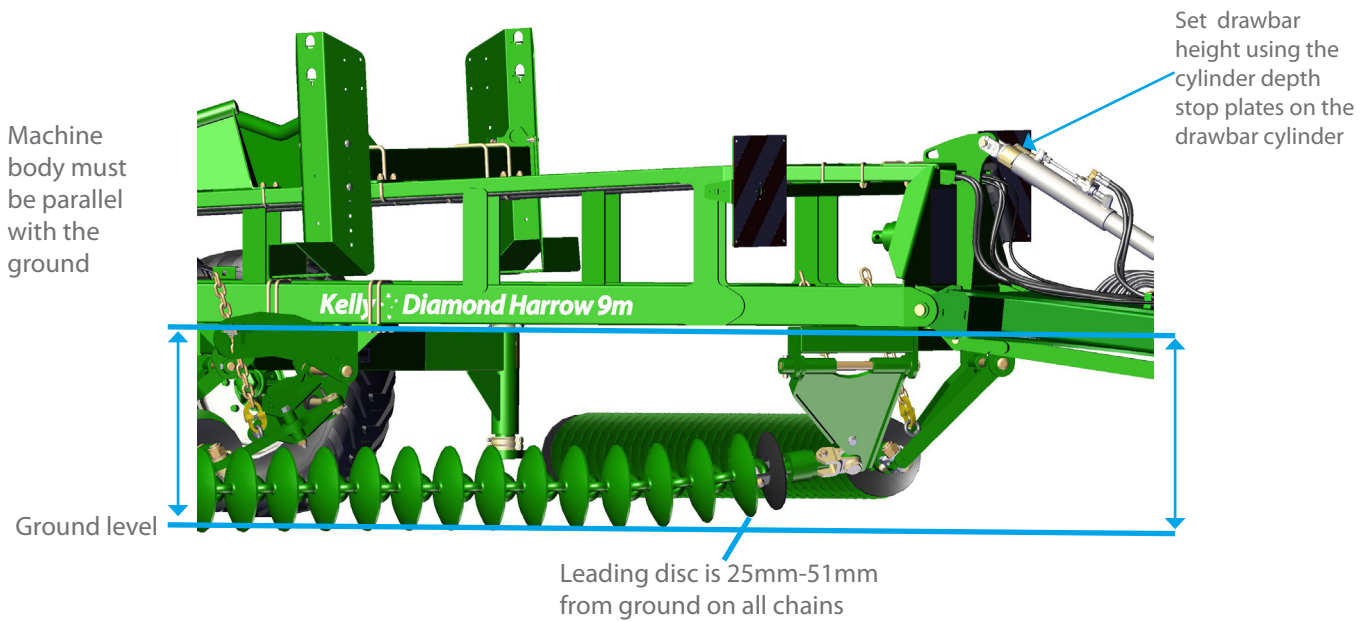

Check the length of the height adjusting chains on the two front chain mount plates. There should be no slack in the chain and about 25-51mm of gap between the ground and the bottom of the first disc. machine near the centre line.

### Chain Mount Plate Rear Height Adjustment

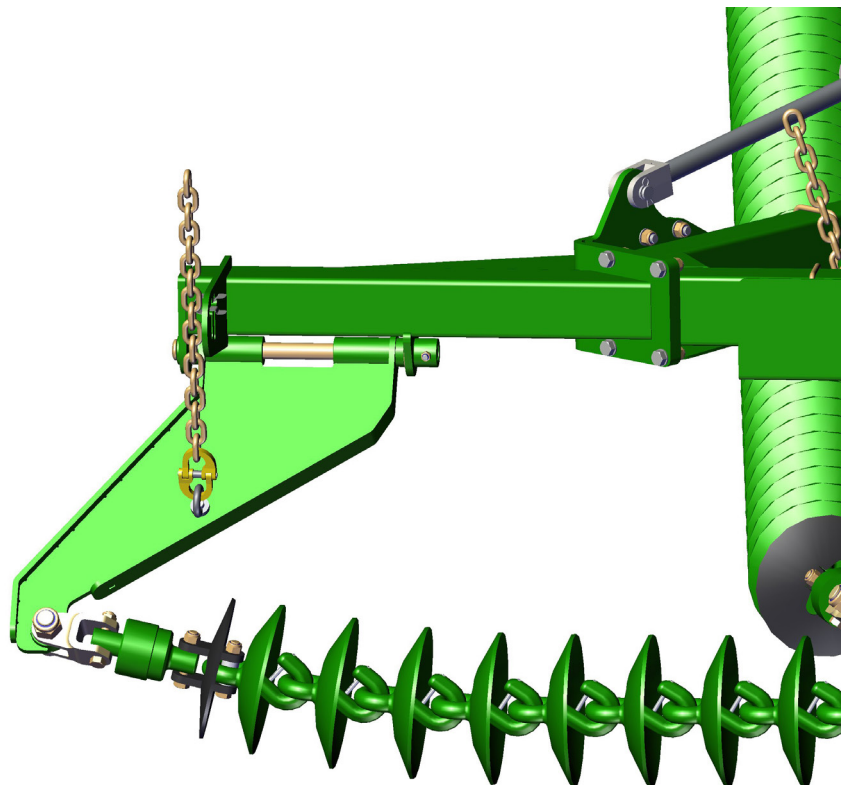

- Check the length of the height adjusting chains on the two tail mount plates.
- The height adjusting chain on the left rear tail chain mount plate should be adjusted so there is 25-51mm of gap between the ground and the last disc.
- The height adjusting plate on the rear chain mount plate should be adjusted so there is 75-100mm of gap between the ground and the last disc.

## Fine adjustment for perfect operating results

You may need to continue to adjust certain areas to achieve a level finish and a perfect seedbed.

It is possible with correct adjustment to achieve a level finish in most situations by manipulating the front and rear heights of each chain.

When set too low, the leading disc on each chain has the capability of pushing up a ridge of soil that the following chains may not level out. This can occur at the front of each chain, at the front of the rear chains (widest point) and at the front of the machine (either side of centre).

When the trailing disc is set too low, it may leave a furrow that may not be filled by other chains. Look for this at the rear of each chain, on the wings at the rear of the front chains and at the very rear of the machine near the centre line.

There is enough overlap built into the machine to ensure that it is possible to raise the front of all of the chains just clear of the ground and still achieve a full cut.

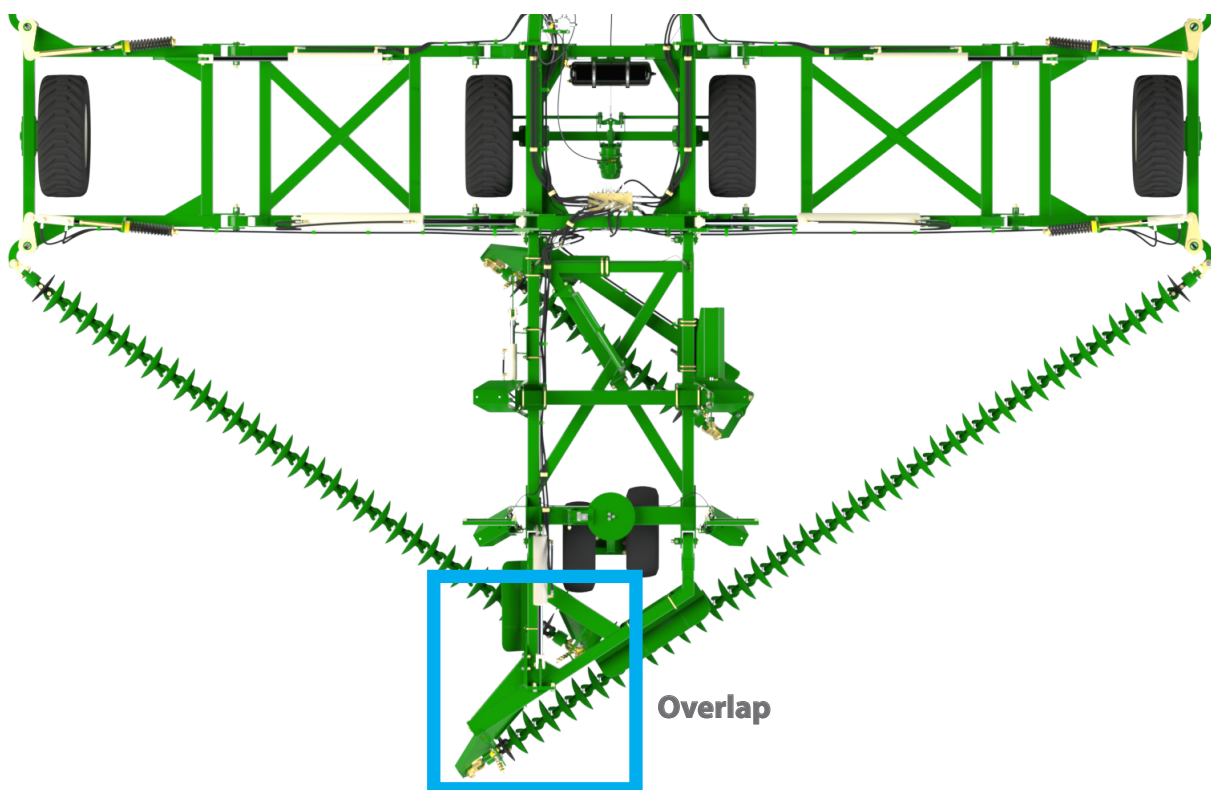

The optimum setting may vary depending on soil cover. In heavy stubble and unworked ground it is possible to set the swivels low to the ground. In light stubble or loose soil it is best to raise the leading discs so that the chains 'feather in' to the soil.

It is important to note that lowering the swivels will not cause the discs to dig deeper or more aggressively. It will result in premature wear of swivel hardware and the first two chain links. It will also cause ridges and furrows.

Digging effectiveness is a result of soil conditions and disc chain construction. The weight, shape, angle and spacing of the discs are the factors which influence efficacy. On hard dry soils it is unrealistic to expect the discs to dig fully or evenly. They will however still perform well for residue breakdown and seed stimulation.

# Section 4

## Hydraulic Sequence Valves

## Sequence Valve Overview

**Hydraulic flow setting on tractor must be set to 20% - Max flow 30 litres per minute**

The sequencing valve manifold incorporated in the Kelly Tillage System provides simple and reliable operation. The manifold is pressure sensitive; once set right, it will give many years of trouble free service. If operating conditions change, it may be necessary to make adjustments to various valves.

This section should help you trouble shoot any problems and make the appropriate adjustments. Factory settings can be found at the beginning of this section, should you need to start again.

Like all hydraulic components, the main enemy is contamination. Care should be taken at all times to prevent contamination entering the hydraulic circuit. Self cleaning line filters are fitted to the tractor hoses on the pressure section of the manifold.

The valve manifold controls the folding and unfolding of the Kelly Tillage System. Two pairs of hoses connect the valve manifold to the tractor. One pair operates the tail and module circuit. The other pair fold and unfold the wings. A third pair of hoses operate the drawbar cylinder.

Oil is directed to the first stage of a fold or unfold sequence. When the cylinders reach the end of their stroke and pressure mounts, a sequence valve is triggered allowing oil to flow to the next stage. The sequence valves automatically reset themselves when system pressure allows.

The valve manifold incorporates over/centre (O/C) or counterbalance valves as a safety measure.

The O/C valves:

- Prevent the tail or wings from falling in the event that one of the tractor hoses fails.
- Manage smooth folding.
- Hold the wings straight out in their working position.

The manifolds incorporate pressure control valves to prevent damage to the machine in case things go wrong when folding.

**Note. The valve manifold has a maximum flow capacity of 30 Lpm.**

**For the purposes of this instruction, view all directions as though standing behind the machine looking forward.**

# Sequence Valve Manifold - Flow Chart

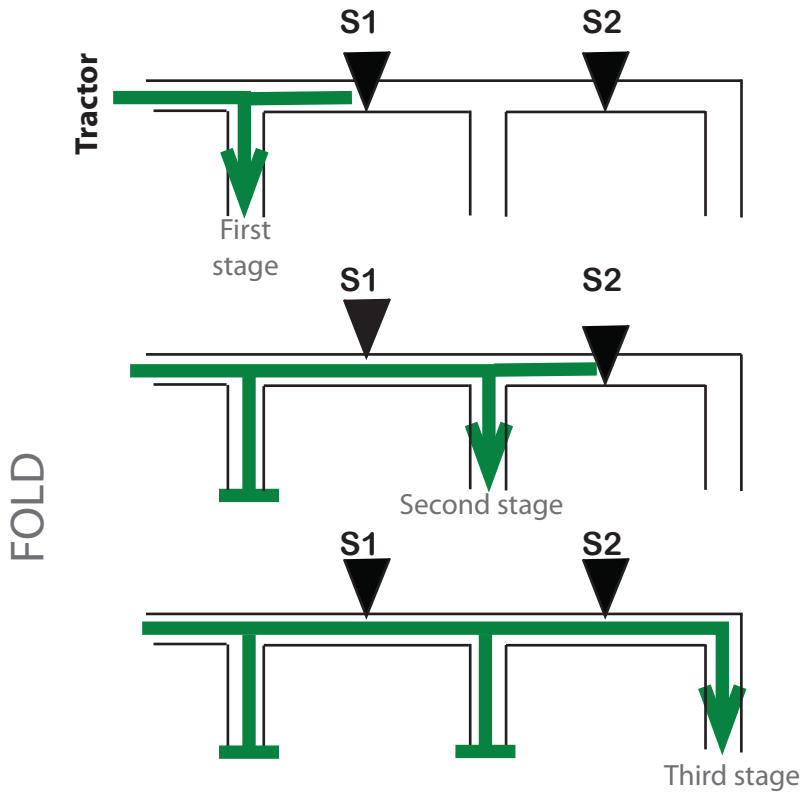

**Step 1 - Raise tail and modules fully**

**Step 2 - Raise wings until folded**

**Stage 1**

S1 closed S2 closed.

Oil is flowing to main wing cylinders

**Stage 2**

S1 open, S2 closed.

Oil is flowing to left outer wing

**Stage 3**

S1 & S2 open. Oil is flowing to right outer wing

**Step 3 - Raise front drawbar assembly fully**

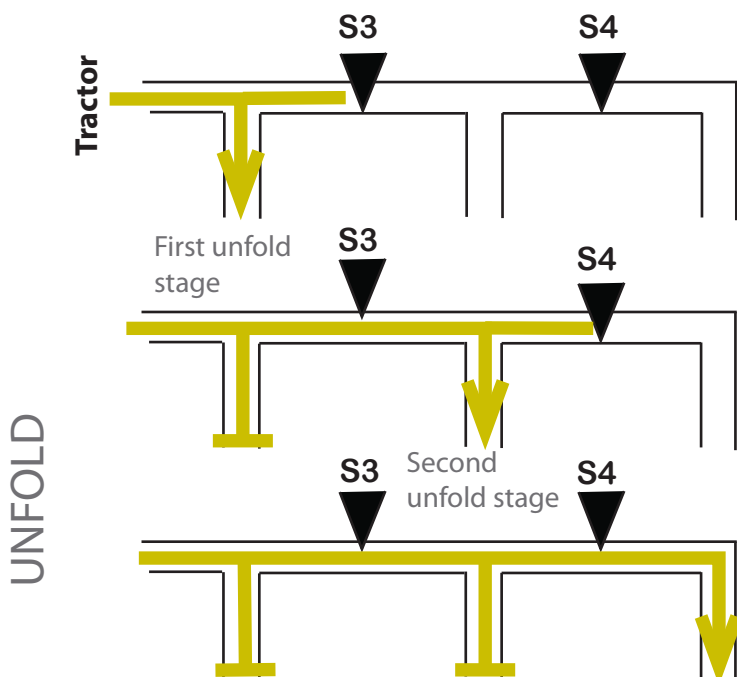

**Step 1 - Lower front drawbar assembly to working position**

**Step 2 - Unfold wings fully**

**Stage 1**

S3 closed. Oil is flowing to right outer wing

**Stage 2**

S3 open, S4 closed.

Oil is flowing to left outer wing

**Stage 3**

S3 open S4 open.

Oil is flowing to main wings, modules and tail

**Step 3 - Lower tail and modules fully.**

## Explanation of Valve Function

### Main wing fold circuit

- E Flow controller to increase or decrease oil flow for extending (unfolding) wing fold cylinders
- R Flow controller to increase or decrease oil flow for retracting (folding) wing fold cylinders
- S1 Sequence valve that remains closed until main cylinders are closed (inner wings fold vertical). It then opens to allow left outer wing to fold
- S2 Sequence valve that remains closed until left outer wing is folded. Then opens to allow right outer wing to fold
- S3 Sequence valve that remains closed until right outer wing unfolds to vertical. It then opens to allow left outer wing to unfold
- S4 Sequence valve that remains closed until left outer wing unfolds to vertical. It then opens to allow main wing cylinders to extend and unfold both main wings to working position
- L1 Over/centre valve that holds main wings in position if tractor hose fails. Prevents wings falling
- L3 Over/centre valve that holds the right wings out straight when working
- L4 Over/centre valve that holds the left wings out straight when working
- C1 Check valve for return oil from right outer wing unfold. Can seem like S2 problem
- C2 Check valve for return oil from left outer wing fold. Can seem like S3 problem
- C3 Check valve for return oil from left outer wing unfold. Can seem like S1 problem
- C4 C5 Check valve for return oil from main wing cylinder folding. Can seem like S4 problem

**Note - Check valves are located on back face of some manifolds. Not all valves are installed in all manifold models.**

### Tail and module circuit

- L2 Over/centre valve that holds tail in raised or partially raised position
- L5 Over/centre valve that holds the two centre module chains up for transport and storage.

## Factory Setting: Table for V12 Sequence Valve Manifolds

| Valve number | Factory setting - turns counter-clockwise from bottoming out | To increase pressure - turn : | To decrease pressure - turn : |
|--------------|--|-------------------------------|-------------------------------|
| S1           | 2 1/2  | Clockwise                     | Counter-clockwise             |
| S2           | 3 1/8  | Clockwise                     | Counter-clockwise             |
| S3           | 3 1/8  | Clockwise                     | Counter-clockwise             |
| S4           | 2 3/4  | Clockwise                     | Counter-clockwise             |
| L1           | 3.5  | Clockwise                     | Counter-clockwise             |
| L2           | 2.25   | Clockwise                     | Counter-clockwise             |
| L3           | 3.5  | Clockwise                     | Counter-clockwise             |
| L4           | 3.75   | Clockwise                     | Counter-clockwise             |
| L5           | 3.5  | Clockwise                     | Counter-clockwise             |

| Valve number | Factory setting - turns counter-clockwise from bottoming out | To increase flow - turn :                            | To decrease flow - turn :                  |
|--------------|--|--|--|
| E            | 2.5  | Counter-clockwise increases flow. One turn is 15 Lpm | Clockwise reduces flow. One turn is 15 Lpm |
| R            | 2.5  | Counter-clockwise increases flow. One turn is 15 Lpm | Clockwise reduces flow. One turn is 15 Lpm |

These settings are true or a very good starting point for all valves, regardless of manifold model.

## HF111938-16, V12 - Split Circuit

Kelly Part Number 0802-691033

### Adjusting Sequence Valve (HF111938-16, V12 - Split Circuit) for the 9m Kelly Diamond Harrow

Valve block model # is on the left end of the valve block, toward the front.  
Internal filters located on left and right ends and underside of valve block.

Make sure tail hoses are on TR1 and TE1.

- 1) Slow down the flow of the tractor hydraulics to 20% or about 30Lpm.
- 2) It may be necessary to remove extra weight such as mud buildup on discs.

Identify if the problem is on the folding or unfolding sequence.

Unfolding = extend and Folding = retract

#### Folding Problems

This valve block is split into two circuits. One set of hoses controls the raising and lowering of the tail and modules independent from the wing fold.

- Raise the tail first.
- Loosen the jam nut on the sequence valve cartridges S1 and S2.
- Increase valve pressure settings by screwing in S1 and S2 (clockwise) until they bottom out.
- Activate the folding circuit with the tractor control valve. The main wings will raise/fold. The left and right outer wings will not fold.
- Screw out S1 (counter-clockwise) until the left outer wing folds then give it another ½ turn. The right outer wing will not fold.
- Screw out S2 (counter-clockwise) until the right outer wing folds then give it another ½ turn.

#### Unfolding Problems

- Before unfolding, check to make sure the discs are not caught on transport rests and guards.
- Loosen the jam nut on the sequence valve cartridges S3 and S4.
- Screw in S3 and S4 (clockwise) until they bottom out. Now activate the unfolding circuit with the tractor control valve. The right outer wing will unfold and nothing else will move.
- Screw out S3 (counter-clockwise) until the left outer wing unfolds then give it another ½ turn. The main wings will not unfold.
- Screw out S4 (counter-clockwise) until the main wings unfold, then give it another ½ turn.
- Since the valve block is split into two parts, you will need to now activate the tail circuit to lower the tail and modules.

When multiple tractors are to be used, set valves to the tractor that has the lowest pressure (typically the oldest tractor).

If the above adjustments have been made and there are still problems, you may want to look at the other check valves and over/centre valves.

Bottom out the valves (clockwise) and then back out (counter-clockwise).



## Over/Centre Valves

L1 – 3.5 turns out; controls main wings from free fall

L2 – 2.25 turns out; controls tail, holds it up for storage and transport

L3 – 3.5 turns out; controls lock up on RH outer wing

L4 – 3.25 turns out; controls lock up on LH outer wing

L5 – 3.5 turns out; controls modules, holds them up for storage and transport

## Check Valves

If a check valve is open due to contamination, the symptom will be as though the corresponding sequence valve is open.

C1 - is the check valve to bypass around S2 (right outer wing) on the folding circuit

C2 - is the check valve to bypass around S3 (left outer wing) on the unfolding circuit

C3 - is the check valve to bypass around S1 (left outer wing) on the folding circuit

C4 - is the check valve to bypass around S4 (main wing) on the unfolding circuit

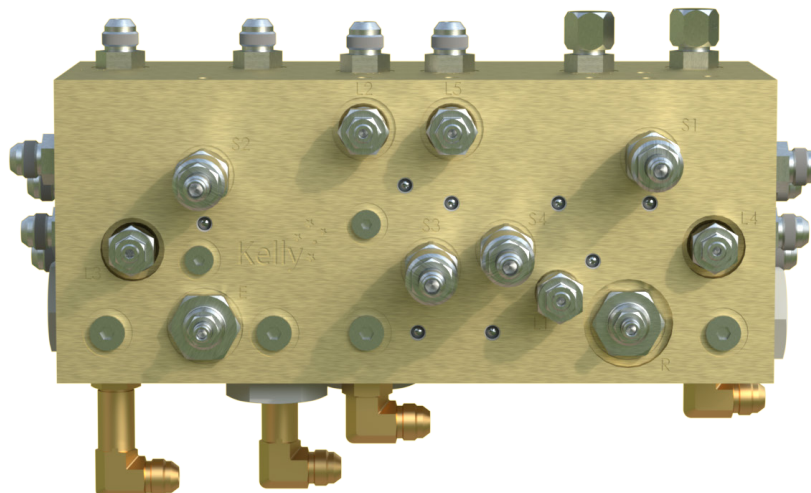

# Section 5

## Maintenance & Inspection

## Maintenance and Inspection

### Good maintenance is your responsibility

- Before working on your machine, ensure all moving parts have stopped
- Always use a safety support and block the wheels
- Use extreme caution when making adjustments
- Replace shields and guards after servicing and before moving
- After servicing, make sure all tools, parts and service equipment are removed
- Where replacement parts are necessary for periodic maintenance and servicing, genuine factory parts must be used. Kelly Engineering will not guarantee the use of unapproved parts and other damages as a result of their use and will not be liable for injury or warranty if equipment has been altered in any way
- An appropriate fire extinguisher and first aid kit should be kept readily available while performing maintenance.

### Intervals

| Item to check   | First operation | Daily | 25 hourly | Pre-season |
|---|-----------------|-------|-----------|------------|
| Hydraulic, hose and cylinders for damage and oil leaks  | ✓               | ✓     |           | ✓          |
| Airline leaks and hose damage   | ✓               | ✓     |           | ✓          |
| Loose or missing fasteners/split pins   | ✓               | ✓     |           | ✓          |
| Check bushes, pivot and cylinder pins for wear and replace as necessary                         |                 |       |           | ✓          |
| Swivel unit fasteners   | ✓               | ✓     |           | ✓          |
| Swivel unit - free and smooth rotation  |                 | ✓     | ✓         | ✓          |
| Swivel unit temperature: Average operating temperature is 55 °C, Failure is indicated at +80 °C | ✓               | ✓     |           | ✓          |
| Tyres are inflated to correct pressure  | ✓               | ✓     | ✓         | ✓          |
| Wheel nuts are tightened at correct torque  | ✓               |       |           | ✓          |
| Check wheel bearings  | ✓               | ✓     | ✓         | ✓          |
| Check and tighten dust caps   | ✓               |       | ✓         | ✓          |
| Tow hitch bolts are tightened at correct torque   | ✓               |       |           | ✓          |
| Disc roll pins/ locking bolts are in place  | ✓               |       |           | ✓          |
| Chain is tensioned correctly  | ✓               | ✓     |           | ✓          |
| Lights are working correctly  | ✓               | ✓     |           | ✓          |
| Warning signs are attached  | ✓               | ✓     |           | ✓          |
| Grease wheel bearings   |                 |       |           | ✓          |
| Grease A frame front lift (6M ONLY)   |                 |       | ✓         | ✓          |



**To prevent injury never lubricate or service the Kelly Tillage System while it is moving (folding up or down or in working motion)**

## Intervals

| Item to check  | First operation | Daily | 25 hourly | Pre-season |
|--|-----------------|-------|-----------|------------|
| Grease wheel lift bush (6M ONLY)   |                 |       | ✓         | ✓          |
| Grease centre cylinder pins x 2  |                 |       | ✓         | ✓          |
| Grease jockey wheel (9M and 12M ONLY)  |                 |       | ✓         | ✓          |
| Grease wing chain tensioner threads (9M and 12M ONLY)                                |                 |       | ✓         | ✓          |
| Grease wing hinge pins x 8   |                 |       | ✓         | ✓          |
| We recommend that swivel units are covered for storage to prevent water penetration. |                 |       |           |            |



**To prevent injury never lubricate or service the Kelly Tillage System while it is moving (folding up or down or in working motion)**

## Maintenance and Inspection

### Chain Inspection

- There is a break-in period where the disc chain will wear in and become longer.
- More frequent adjustments will be necessary on a new machine.
- Don't forget to check the module disc chains when checking the main disc chains.
- Over time, as the disc chain wears, it may be necessary to remove a link to maintain disc chain tension. This is the most important check and adjustment to ensure a long working life for the disc chain.

### Trouble Shooting

The majority of the Kelly Tillage System operating problems are due to incorrect adjustment. This trouble shooting section may help you by providing solutions to common problems.

| Symptom  | Problem  | Solution  |
|--|--|---|
| Wings bouncing                                 | Wing tyre pressure too low                       | Refer to page 57 for tyre pressure specifications             |
|  | Operating speed is too fast for field conditions | Refer to page 57 for operating speed                          |
| Chain Links wearing                            | Chain too loose. Chain loops back when working.  | Refer to page 24 for setting correct chain tension            |
|  | Swivel set too close to ground.                  | Refer to page 33 - 34   |
| Chain not rotating                             | Bearing failure in swivel unit                   | Refer to daily checks on page 43 - 44                         |
|  | Front chain swivels on machine too low           | Refer to page 33 - 34   |
|  | Foreign material fouling bearings                |   |
| Uneven tread wear on transport wheels          | Tyre pressure too low                            | Inflate to correct pressure refer to table on page 57         |
|  | Excessive road speed                             | Always travel at a safe speed. <b>NEVER EXCEED 25kph.</b>     |
| Chains not locating properly on transport rest | Transport rest not correctly precision           | Adjust transport rest precision until chain locates correctly |
| Operation leaves central ridge behind machine  | Front chain swivels are too low                  | Refer to chain mount plate height adjustment on page 32       |



**Never attempt to fold for transport if the chain is clogged with weeds or mud as the extra weight may damage hydraulics or frame**

## Trouble Shooting

| Symptom  | Problem  | Solution  |
|--|--|---|
| Operation leaves central ridge behind machine  | Front chain swivels are too low                    | Refer to chain mount plate height adjustment on page 32 |
| Operation leaves central furrow behind machine | Rear chain swivels are too low                     | Refer to chain mount plate height adjustment on page 32 |
| Ridging on outside edge of machine             | Leading end of corresponding rear chain is too low | Refer to drop leg height adjustment on page 30          |
| Furrow on outside edge                         | Rear of front chain set too low                    | Refer to drop leg height adjustment on page 30          |
| Chain not tensioning properly                  | Excessively worn chain                             | Replace if required                                     |
|  | May need a link removed                            | Remove excess chain link                                |

## Trouble Shooting - Hydraulic Sequence Valves

| Problem with:     | Symptom   | Page |
|-------------------|---|------|
| <b>Unfolding</b>  | Right wing won't rise from folded position                                  | 48   |
|                   | Right wing rises but left wing won't rise                                   | 49   |
|                   | Centre cylinders extend before outer wings are both straight (vertical)     | 49   |
|                   | Both wings stand vertical then stop   | 50   |
|                   | No movement at all  | 50   |
|                   | Sequence was working but becomes erratic                                    | 50   |
| <b>Folding</b>    | No movement at all  | 51   |
|                   | Both main wings stand vertical then left wing won't fold.                   | 51   |
|                   | Left hand outer wing folds before both inner wings are vertical             | 52   |
|                   | Right hand outer wing folds before both inner wings are vertical            | 52   |
|                   | Main wings fold, left outer wing folds the right outer wing stands vertical | 53   |
|                   | Outer wings collide when folding  | 53   |
|                   | Left outer wing stands vertical and right outer wing folds over             | 54   |
|                   | Sequence was working but becomes erratic                                    | 54   |
|                   | No movement at all  | 54   |
| <b>Working</b>    | Wings sag in middle when working  | 55   |
| <b>Unresolved</b> | Contact service agent or manufacturer                                       | 55   |

## Trouble Shooting - Hydraulic Sequence Valves

### Dual Function

Version 12 manifolds allow independent raising and lowering of the tail section. This means that when crossing roadways or waterways, the front and rear can be quickly raised to lift the chains clear of the ground. This allows you to back into corners of fields and improves turning on end rows.

This requires 3 pairs of tractor remotes to operate. It will be possible to operate the machine successfully on a tractor with only two circuits after some minor alterations to hose connections and routing.

### Unfolding

During unfolding, the following sequence must be observed.

1. Lower front drawbar to working height.
2. Unfold wings, holding the hydraulic lever until the main centre cylinder pins have centered in their slots.
3. Lower rear tail by holding hydraulic lever until tail and modules are completely lowered to working position and the wing de-tensioning cylinders are fully retracted, tensioning the chain.

When unfolding the wings, oil travels directly to the right hand outer wing cylinders until they are fully extended. Oil then opens S3 and flows to the left hand outer wing cylinders. When these are fully extended, oil pressure opens S4 and flows to the centre frame hydraulic cylinders pushing the extended wings to the ground. There is an over/centre valve, L1, that protects the main wings from falling and controls their descent.

## Trouble Shooting - Hydraulic Sequence Valves

### RIGHT WING WON'T RISE FROM FOLDED POSITION

If the pressure required to raise the right wing is greater than tractor pressure, the oil will not flow. This may occur if chain is full of mud or other matter, which increases the weight of the chain. It may also occur on tractors with lower than original hydraulic oil pressure.

- If the pressure setting of S3 is too low, it can open before lifting the top wing. Oil will then try to raise the second wing, which is trapped and can not move. The main cylinders will try to force the wings apart.
- Disc chain may be caught on one of the chain supports or guards, especially on the tail, preventing the wing from lifting. Usually you will see the top wing raise a little then stop if this is the case.
- Oil may bypass a cylinder piston seal if the seal or piston has failed. You will hear oil flowing in one cylinder and that cylinder should warm up compared to the remaining cylinders.
- Check-valves C4 or C5 may be held open by contamination allowing oil to flow to left wing or main cylinders.

### Solution

- Clean chains of mud and debris.
- Check the disc chain for areas it might be caught and make adjustments to support brackets or folding procedure.
- Increase the pressure setting on S3 by 1/2 turn clockwise (repeat if required).
- Remove check-valve C4 or C5 and inspect.
- If oil is flowing through the manifold but no movement is occurring, then it is possible that a piston seal has failed. Sequentially isolate cylinders until culprit is identified (**WARNING**: Fold wings to transport position before removing cylinders, DEATH or INJURY could result).
- Check that tractor hydraulic oil pressure is adequate (2200psi / 151Bar).



## Trouble Shooting - Hydraulic Sequence Valves

### RIGHT WING RISES BUT LEFT WING WON'T RISE

If the pressure required to raise the left wing is greater than tractor pressure, the oil will not flow. This may occur if chain is full of mud or other matter increasing the weight of the chain. It may also occur on tractors with lower than original hydraulic oil pressure. Left wing is heavier than right wing and may require more pressure to lift.

- If the pressure setting of S3 is too high then oil will stall and left wing will not raise.
- Disc chain may be caught on one of the chain supports, especially on the rear "M" bracket mounts, preventing the wing from lifting.
- Oil may bypass a cylinder piston seal if the seal or piston has failed. You will hear oil flowing in one cylinder and that cylinder should warm up compared to the remaining cylinders.
- A check-valve may be stuck open allowing oil to bypass.

#### Solution

- Clean chains of mud and debris.
- Check the disc chain for areas it might be caught and make adjustments to support brackets or folding procedure.
- Decrease the pressure setting on S3 by 1/2 turn clockwise (repeat if required).
- Remove and inspect check-valve C4. Clear any contamination and reinstall.
- If oil is flowing through the manifold but no movement is occurring, then it is possible that a piston seal has failed. Sequentially isolate cylinders until culprit is identified (**WARNING:** Fold wings to transport position before removing cylinders, DEATH or INJURY could result).
- Check that tractor hydraulic oil pressure is adequate (2200psi / 151Bar).

### CENTRE CYLINDERS EXTEND BEFORE OUTER WINGS ARE BOTH STRAIGHT (VERTICAL)

If the pressure required to raise the right wing is greater than that set by S3 then oil will flow past S3 to the left wing. As the right wing rests on top of the left wing and neither can move then oil is also forced past S4 to the main wing cylinders causing them to extend while the outer wings are still folded. As the main wings unfold and the weight is transferred from the outer wings then the oil will flow to the outer wing cylinders allowing the wings to straighten. Do not allow this to continue as the cylinder pins will shear and the wings will fall uncontrolled.

The same symptom will occur if check valve C4 is held open by contamination.

As above, mud or debris in the chain will change the load and operating pressure required to lift the outer wings.

#### Solution

- If chains are clean, increase the pressure setting on S3 (right wing will raise).
- Increase pressure setting on S4 (left wing will raise).
- Remove and inspect check-valve C4. Clear any foreign material from around ball and seat area.

## Trouble Shooting - Hydraulic Sequence Valves

### **BOTH WINGS STAND VERTICAL THEN STOP**

Once the outer wings have stood vertical oil pressure opens S4 and allows flow to the main wing cylinders. An over/centre valve, L1 prevents the wings from falling and controls their descent to working position.

#### **Solution**

- Lower pressure setting on S4, screw centre counter-clockwise 1/2 turn, check and repeat if needed.
- L1 over/centre valve may be set too high, preventing return oil flowing to tank. Reduce pressure setting on L1 by turning CLOCKWISE 1 turn.
- Check that hydraulic flow on the tractor is not set to very low or off.
- Check tractor hydraulic pressure (should exceed 2200 psi -151 Bar).
- Call service technician. Test for oil flow. If flow is present isolate cylinders one at a time to ensure integrity of cylinder piston seal (**WARNING:** Fold wings to transport position before removing cylinders, DEATH or INJURY could result).

### **NO MOVEMENT AT ALL**

#### **Solution**

- See first point. Check, and if necessary, clean chains of mud or debris.
- Check that hose tips are correctly engaged in tractor breakaway sockets.
- Check that any taps or electronic transport locks are open on the tractor.
- Check that hydraulic flow on the tractor is not set to very low or off.
- Check tractor hydraulic pressure (should exceed 2200 psi -151 Bar).
- Call service technician. Test for oil flow. If flow is present, isolate cylinders one at a time to ensure integrity of cylinder piston seal. (**WARNING:** Fold wings to transport position before removing cylinders, DEATH or INJURY could result).

### **SEQUENCE WAS WORKING BUT HAS BECOME ERRATIC**

The sequence valve manifold has an oil flow capacity of 30 Lpm. At this flow, the sequence cartridges are able to cope with the flow of oil and operate at their correct settings. If the flow rate is set too high, pressure in the manifold builds up and may unseat the sequence valves prematurely or in an unpredictable manner.

#### **Solution**

- Set tractor hydraulic remote oil flows to slow (20%).
- Engage tractor hydraulic lever slowly.
- Reduce flow by screwing flow control valve E counterclockwise 2 turns.

## Trouble Shooting - Hydraulic Sequence Valves

### Folding

The fold sequence is as follows:

1. Lower the front drawbar to working height. (This is important to ensure that all chains locate correctly in their transport rests).
2. Raise the rear tail and modules by holding the hydraulic lever until they come to a complete stop.
3. Fold the wings. They should move as follows; main centre cylinders will retract, one or both, until the wings stand vertically. The left outer wing, then the right outer wing will fold down.
4. Raise front drawbar to transport height.

**During folding, oil travels directly to the main wing cylinders. When these are all closed, oil then opens S1 allowing oil to flow to the left outer wing cylinders. When these cylinders close, oil pressure opens S2 to fold the right outer wing.**

### NO MOVEMENT AT ALL

The main cylinders are the first to receive oil from tractor and should lift the wings. Failure to operate as expected could indicate excess mud in the discs. If the tail has not been raised it is possible that the wings will not lift up as the chain tension prevents them from rising.

#### Solution

- Clean mud from the discs.
- Raise the tail section fully prior to folding the wings.

### BOTH MAIN WINGS STAND VERTICAL THEN LEFT WING WON'T FOLD

Oil flows straight from tractor to the main cylinders. Once raised oil must then force S1 open to allow flow to the left outer wing. If S1 is set too high then oil flow will stall and the left outer wing will not fold.

Over/centre valve L4 is used to hold the left wing straight during operation. If L4 is set at too high a pressure, the left wing will not fold. L4 is a pilot operated valve and requires correct system pressure to function.

#### Solution

- Reduce the pressure setting on S1 by screwing counter-clockwise 1/2 turn (repeat as required).
- Reduce pressure setting on L4 by screwing counter-clockwise 1 turn.

## Trouble Shooting - Hydraulic Sequence Valves

### LEFT HAND OUTER WING FOLDS BEFORE BOTH INNER WINGS ARE VERTICAL

If the pressure required to raise the wings to vertical is greater than the pressure setting on S1, then oil will pass S1 and cause the left hand outer wing cylinders to retract. This may occur if there is excessive load such as mud or debris or on occasions where the chains may have become blocked and buried.

The same symptom can be seen if check-valve C3 is held open by contamination.

#### Solution

- Check and, if necessary, clean any mud or debris from chains. Do not attempt to fold the machine if the chains are buried during a blockage. Clear away the soil from the chains first.
- If the chains are clean but problem persists, it may be necessary to adjust S1. Increase the pressure setting by screwing clockwise 1/2 turn.
- Remove and clean C3 check-valve.

### RIGHT HAND OUTER WING FOLDS BEFORE BOTH INNER WINGS ARE VERTICAL

In the normal folding process the left wing must fold before the right wing. Even if both S1 and S2 have pressure settings that are too low, then both wings will move together. For the right outer wing to move first, check-valve C1 must be open.

#### Solution

- Remove and clean C1 check-valve.

## Trouble Shooting - Hydraulic Sequence Valves

### MAIN WINGS FOLD, LEFT OUTER WING FOLDS THEN RIGHT OUTER WING STANDS VERTICAL

Oil is forced to the left outer wing cylinders which cause the left wing to fold down. Once these cylinders are closed, oil pressure increases and opens S2 allowing oil to flow to the right hand outer wing cylinders. If S2 is set too high, the oil flow can stall after left outer wing is folded.

Over/centre valve L3 is used to hold the right wing straight during operation. If pressure setting on L3 is too high, the left wing will not fold. L3 is a pilot operated valve and requires correct system pressure to function.

#### Solution

- Reduce the pressure setting on S2 by screwing counter-clockwise 1/2 turn (repeat as required).
- Reduce pressure setting on L3 by screwing counter-clockwise 1 turn.

### OUTER WINGS COLLIDE WHEN FOLDING

If you witness the two outer wings coming together when folding you must immediately stop and reverse the operation. Unfold the wings to vertical then recommence slowly. The individual wings should fold in sequence. If they both continue to fold together, then oil must be passing S2 prematurely. For this to happen S2 has pressure set too low.

#### Solution

- Increase the pressure setting on S2 by screwing clockwise 1/2 turn (repeat as required).

## Trouble Shooting - Hydraulic Sequence Valves

### LEFT OUTER WING STANDS VERTICAL AND RIGHT OUTER WING FOLDS OVER

The main wings stand vertical, then the left wing does not move, but the right hand outer wing folds over and then all movement stops. This can occur when the L4 over/centre valve that holds the wing straight during operation in the field, will not release and allow the wing to fold. L4 could be contaminated but would usually stick open. L4 could have failed but this is rare.

#### Solution

- Decrease the pressure setting on L4 by screwing it counter-clockwise 1/2 turn.

### SEQUENCE WAS WORKING FINE BUT HAS BECOME ERRATIC

The sequence valve manifold has an oil flow capacity of 30 Lpm. At this flow the sequence cartridges are able to cope with the flow of oil and operate at their correct settings. If the flow rate is set too high, pressure in the manifold builds up and may unseat the sequence valves prematurely or in an unpredictable manner.

Occasionally foreign material may lodge in one of the check-valves. This will allow oil to flow in a seemingly illogical manner. Symptoms suggest valve adjustments however the logical adjustments have no effect.

#### Solution

- Set tractor hydraulic remote oil flows to slow (20%).
- Engage tractor hydraulic lever slowly.
- Reduce flow by screwing flow control valve R counter-clockwise 2 turns.

### NO MOVEMENT AT ALL

#### Solution

- Check that hose tips are correctly engaged in tractor breakaway sockets.
- Check that any shut off valves or electronic transport locks are open on the tractor.
- Check that hydraulic flow on the tractor is not set to very low or off.
- Check tractor hydraulic pressure (should exceed 2200psi - 151 Bar).
- Call service technician. Test for oil flow. If flow is present isolate cylinders one at a time to ensure integrity of cylinder piston seal.

## Trouble Shooting - Hydraulic Sequence Valves

### Working

#### Wings "sag" in middle while working

Both sets of wings are locked straight in working position by the L4 and L3 over/centre valves. If the pressure setting on these valves is too low, the wings may not be effectively locked.

#### Solution

- Left wing sagging - increase the pressure setting on L4 by screwing it COUNTER-CLOCKWISE 1/2 turn.
- Right wing sagging - increase the pressure setting on L3 by screwing it COUNTER-CLOCKWISE 1/2 turn.

## Contact Details

#### IF THESE ADJUSTMENTS DO NOT SOLVE THE PROBLEM

Contact your service agent for assistance. There may be a fault with one of the cartridges. The valve manifolds are tested at factory and again prior to shipping. The assembling agent will also have ensured the correct operation prior to delivery. Very rarely, but occasionally, valves do fail. The usual cause is ingress of contaminant.

You may also contact Kelly for technical advice and assistance.

**Phone** : +618 8667 2253

**Email**: sales@kellytillage.com

# Section 6

## Specifications



## Operating Speeds

| Operating speeds for normal conditions |           |
|--|-----------|
| Chain type                             | Speed     |
| Prickle Chain                          | 10-16 kph |
| Disc Chain                             | 10-12 kph |
| Transport / towing on roads            | 25 kph    |

## Tyre Pressure

| Tyre size    | Ply | KPA | PSI |
|--------------|-----|-----|-----|
| 400/55-22.5  | 18  | 350 | 50  |
| 10.0/75-15.3 | 14  | 300 | 44  |

## Bolt Torque Settings

| Bolt Type | Wheel nut | U Bolt |     |     | Class 8.8 Bolt |      |      |      |      |     |     | Class 10.9 Bolt |
|-----------|-----------|--------|-----|-----|----------------|------|------|------|------|-----|-----|-----------------|
| Bolt Size | M18       | M12    | M16 | M20 | M6             | M8   | M10  | M12  | M16  | M20 | M24 | M20             |
| Spanner   | 27        | 19     | 24  | 30  | 10             | 13   | 17   | 19   | 24   | 30  | 36  | 30              |
| Nm (max)  | 270       | 50     | 75  | 260 | 9.9            | 18.1 | 28.8 | 41.9 | 78.8 | 127 | 183 | 181             |

[1] When fitting a wheel and tyre to a hub, tighten the wheel nuts in a star pattern to the correct tension. To achieve this, choose a wheel nut and tighten, then proceed to the opposite side of the hub to the next wheel nut and tighten and so on until all wheel nuts are tight. Then repeat the procedure to check that all nuts are tight. Do not use impact tools to tighten wheel nuts. For a guide to the correct tension of the wheel nuts, please use the appropriate tension for your size wheel nuts from the Bolt Torque Settings table.

Torque values are for dry threads and surfaces however, it is permissible to apply a small amount of anti corrosive oil to the threads.

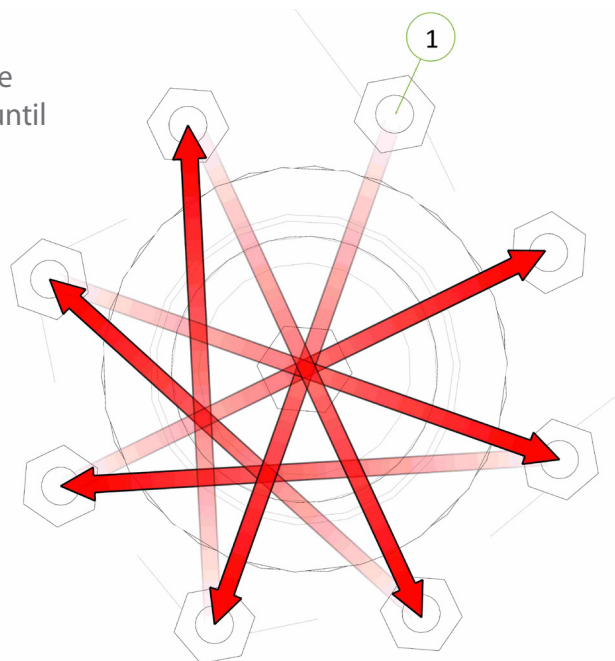

## Disc Chain Lengths and Quantities

| Model     |              | Length | CL2   | CL1 | W36 | R300 | SD49 | Prickle chain |
|-----------|--------------|--------|---|-----|-----|------|------|---------------|
|           |              |        | CL2 disc chain also requires CL1 disc chain |     |     |      |      |               |
| <b>9m</b> | Front right  | 5.48m  | CL2 - 24<br>CL1 - 2                         | 33  | 32  | 44   | 44   | 61            |
|           | Front left   | 5.48m  | CL2 - 24<br>CL1 - 2                         | 33  | 32  | 44   | 44   | 61            |
|           | Rear right   | 6.70m  | CL2 - 23<br>CL1 - 11                        | 41  | 39  | 53   | 53   | 74            |
|           | Rear left    | 5.97m  | CL2 - 21<br>CL1 - 2                         | 30  | 29  | 40   | 40   | 55            |
|           | Front module | 1.99m  | CL2 - 7<br>CL1 - 3                          | 12  | 12  | 16   | 16   | 22            |
|           | Rear module  | 1.65m  | CL2 - 6<br>CL1 - 2                          | 10  | 10  | 13   | 13   | 18            |

For correct chain tension, chain links may need to be removed from the end of the chain as follows:

CL2 Disc Chain - unhook disc chain link/s from end of the disc chain

CL1 Disc Chain - unhook disc chain link/s from end of the disc chain

K4 Disc Chain - unhook disc chain link/s from end of the disc chain

Spiked Disc Chain - cut a disc chain link from the end of the disc chain

R300 Disc Chain - cut a disc chain link from the end of the disc chain

W36 Disc Chain - cut a disc chain link from the end of the disc chain

Prickle Chain - cut a prickle chain link from the end of the prickle chain





