

Section 4:

Sequence valve adjustments 290430

For models 40 / 45 / 45R / 50 / 60

Nov 2013 - Jan 30 2014 -

	Page
Sequence valve manifold (pic)	2
Sequence valve overview	2
Sequence valve manifold flow chart	3
Trouble shooting	4
Unfolding	4
Folding	8
Technical advice and assistance details	12
Explanation of valve functions	14

Sequence valve adjustments

Hydraulic flow setting on tractor must be set to 20% - Max flow 8 gallons per minute

Hydraulic valve manifold - 290430 Split Circuit

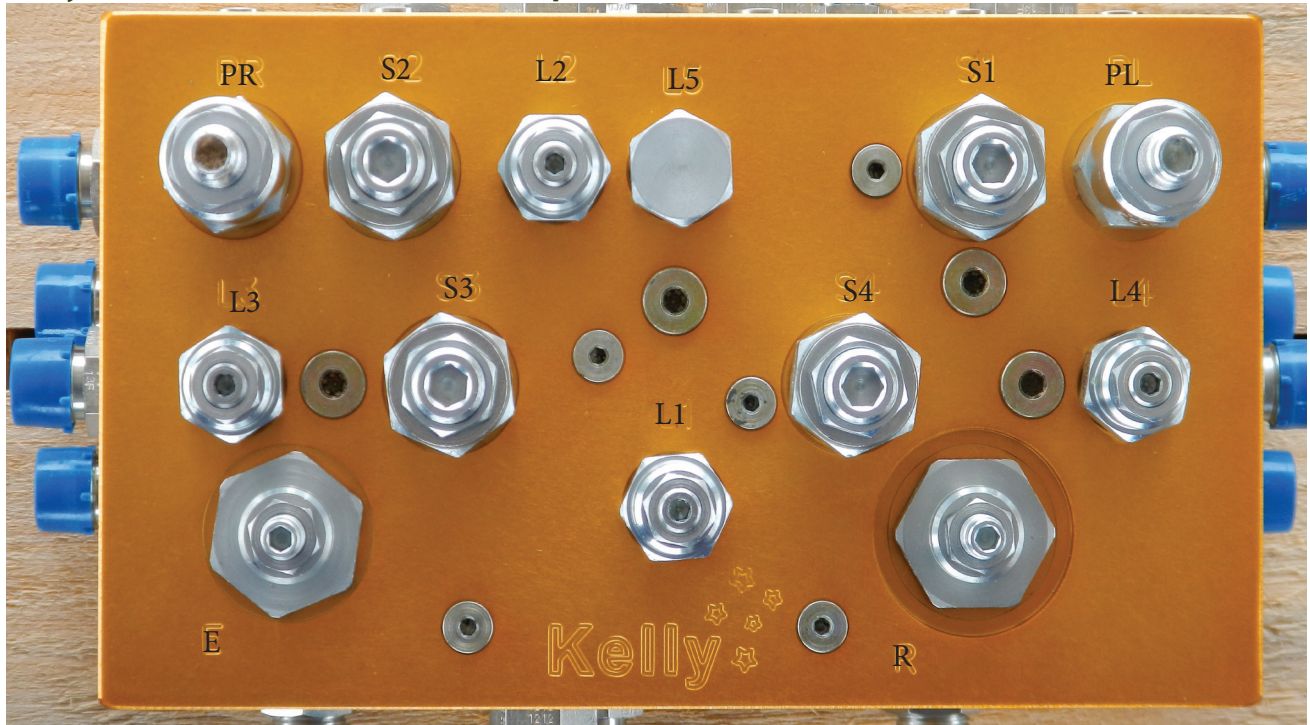

Sequence valve overview

The sequencing valve manifold incorporated in Kelly Engineering Diamond Series Chain Harrow provides simple and reliable operation. The manifold is pressure sensitive, once set right it will give many years of trouble free service. If operating conditions change it may be necessary to make adjustments to various valves. This sections should help you trouble shoot any problems and make the appropriate adjustments. At the end of the section are the factory settings, should you need to start again.

Like all hydraulic components the main enemy is contamination. Care should be taken at all times to prevent contamination entering the hydraulic circuit. Self cleaning line filters are fitted to the tractor hoses on the sequence section of the manifold.

The valve manifold controls the folding and unfolding of the Diamond Chain Harrow. Two pairs of hoses connect the valve manifold to the tractor. One pair operates the tail and module circuit. The other pair fold and unfold the wings. A third pair of hoses operate the tongue cylinder. Oil is directed to the first stage of a fold or unfold sequence. When the cylinders reach the end of their stroke and pressure mounts, a sequence valve is triggered allowing oil to flow to the next stage. The sequence valves automatically reset themselves when system pressure allows.

The valve manifold incorporates over-center valves as a safety measure. These O/C valves prevent the tail or wings from falling in the event that one of the tractor hoses should fail, manage smooth folding and hold the wings straight out in their working position. This new type manifold incorporates pressure control valves to prevent damage to the machine in case things go wrong when folding.

Note. The valve manifold has a maximum flow capacity of 8 Gallons (US) per minute (30Lpm). For the purposes of this instruction **view all directions as though standing behind the machine looking forward.**



Sequence valve adjustments

Sequence valve manifold flow chart

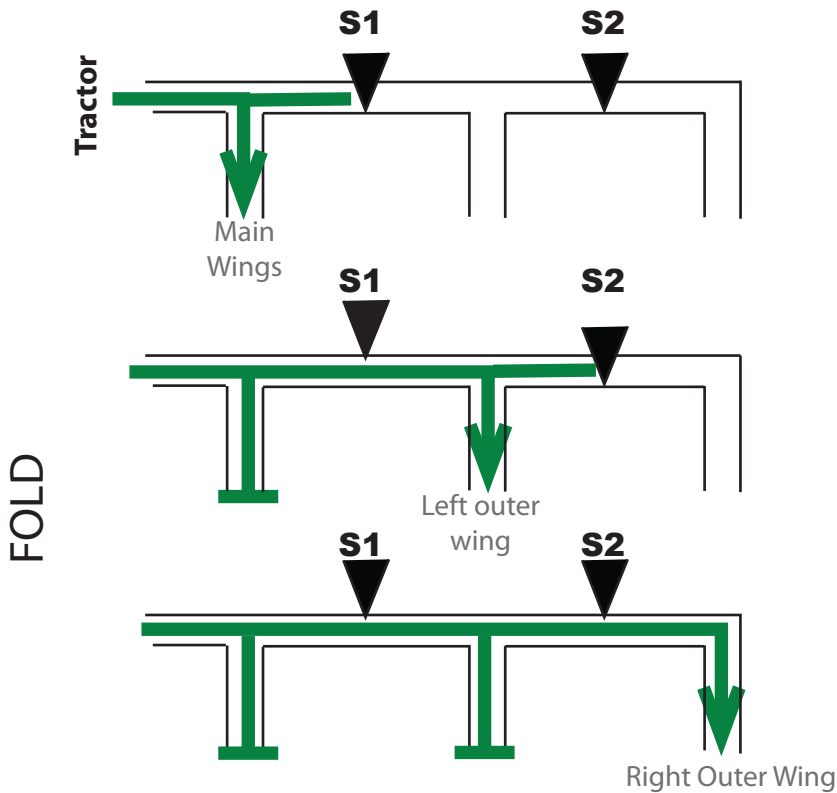

Step 1 -Raise Tail and Modules fully.

Step 2- Raise wings until folded

Stage 1

S1 closed S2 closed.
Oil is flowing to main wing cylinders

Stage 2

S1 open, S2 closed.
Oil is flowing to left outer wing

Stage 3

S1 & S2 open. Oil is flowing to right outer wing

Step 3- Raise front tongue assembly fully

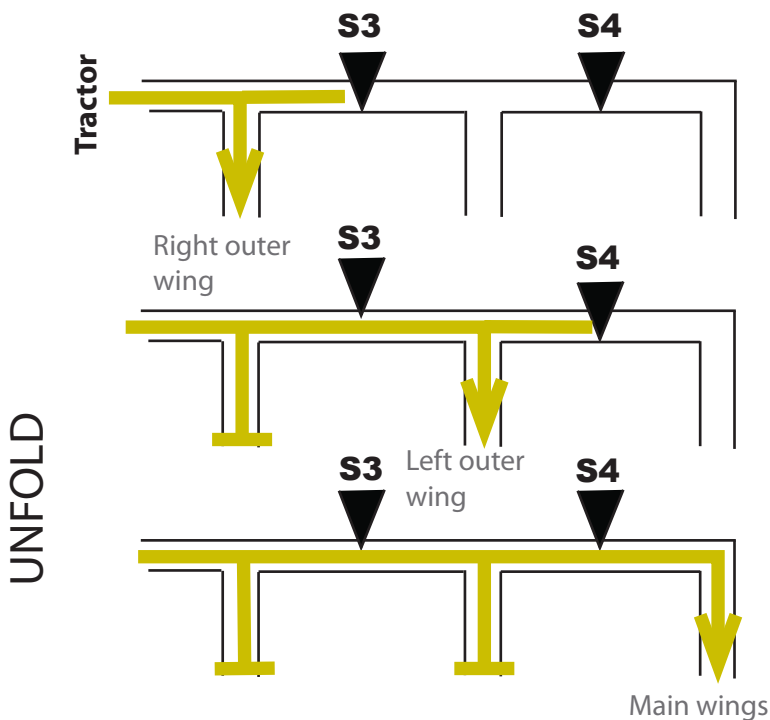

Step 1 -Lower front tongue assembly to working position.

Step 2 Unfold wings fully

Stage 1

S3 closed. Oil is flowing to right outer wing

Stage 2

S3 open, S4 closed.
Oil is flowing to left outer wing

Stage 3

S3 open S4 open.
Oil is flowing to main wings, modules and tail

Step 3 - Lower Tail and Modules fully.

EXPLANATION OF VALVE FUNCTION

Main wing fold circuit

- E Flow controller to increase or decrease oil flow for extending (unfolding) wing fold cylinders
- R Flow controller to increase or decrease oil flow for retracting (folding) wing fold cylinders
- PR Pressure reducing valve to protect right wings when folding
- PL Pressure reducing valve to protect left wings when folding
- S1 Sequence valve that remains closed until main cylinders are closed. (inner wings fold vertical) It then opens to allow left outer wing to fold.
- S2 Sequence valve that remains closed until left outer wing is folded. Then opens to allow right outer wing to fold.
- S3 Sequence valve that remains closed until right outer wing unfolds to vertical. It then opens to allow left outer wing to unfold.
- S4 Sequence valve that remains closed until left outer wing unfolds to vertical. It then opens to allow main wing cylinders to extend and unfold both main wings to working position.
- L1 Over Centre valve that holds main wings in position if tractor hose fails. Prevents wings falling.
- L3 Over Centre valve that holds the right wings out straight when working.
- L4 Over Centre valve that holds the left wings out straight when working.
- C1 Check valve for return oil from right outer wing unfold. Can seem like S2 problem
- C2 Check valve for return oil from left outer wing fold. Can seem like S3 problem
- C3 Check valve for return oil from left outer wing unfold. Can seem like S1 problem
- C4 Check valve for return oil from main wing cylinder folding. Can seem like S4 problem

Note - Check valves are located on back face of manifold.

Tail & Module circuit

- L2 Over Centre valve that holds tail in raised or partially raised position
- L5 Over Centre valve that holds the two centre module chains up for transport & storage.



Sequence valve adjustments

Trouble shooting

Problem with:	Symptom	Page
Unfolding	Right wing won't rise from folded position	5
	Right wing rises but left wing won't rise	6
	Center cylinders extend before outer wings are both straight (vertical)	6
	Both wings stand vertical then stop.	7
	No movement at all	7
	Sequence was working but becomes erratic	7
	Folding	No movement at all
Both main wings stand vertical then left wing wont fold.		8
Left hand outer wing folds before both inner wings are vertical		9
Right hand outer wing folds before both inner wings are vertical		9
Main wings fold, left outer wing folds the right outer wing stands vertical		9
Outer wings collide when folding		10
Left outer wing stands vertical and right outer folds over.		11
Sequence was working but becomes erratic		11
Working	Wings sag in middle when working.	12
Unresolved	Contact service agent or manufacturer	38

Dual Function

Manifold 290430 has the ability to allow independent raising and lowering of the tail section. This means that when crossing roadways or waterways the front and rear can be quickly raised to lift the chains clear of the ground. Allows you to back into corners of fields and improves turning on end rows. The new functionality requires 3 pairs of tractor remotes to operate. It will be possible to operate the machine successfully on a tractor with only two circuits after some minor alterations to hose connections and routing.

Unfolding

During unfolding the following sequence must be observed.

1. Lower front tongue assembly to working height
2. Unfold wings fully until main cylinder pins centre in their slots.
3. Lower tail and modules fully.



Sequence valve adjustments

When unfolding the wings, oil travels directly to the right hand outer wing cylinders until they are fully extended. Oil then opens S3 and flows to the left hand outer wing cylinders. When these are fully extended, oil pressure opens S4 and flows to the center cylinders pushing the extended wings to the ground. There is an over-center valve, L1, that protects the main wings from falling and controls their decent.

RIGHT WING WON'T RISE FROM FOLDED POSITION

If the pressure required to raise the right wing is greater than tractor pressure then oil will not flow. This may occur if chain is full of mud or other matter increasing the weight of the chain. It may also occur on tractors with lower than original hydraulic oil pressure.

If the pressure setting of S3 is too low it can open before lifting the top wing. Oil will then try to raise the second wing, which is trapped and can not move. The main cylinders will try to force the wings apart.

Disc chain may be caught on one of the saddles or supports, especially on the tail, preventing the wing from lifting. Usually you will see the top wing raise a little then stop if this is the case.

Oil may bypass a cylinder piston seal if the seal or piston have failed. You will hear oil flowing in one cylinder and that cylinder should warm up compared to the remaining cylinders.

Check-valves C4 or C5 may be held open by contamination allowing oil to flow to left wing or main cylinders.

Solution

- Clean chains of mud and debris.

- Check the disc chain for areas it might be caught and make adjustments to support brackets or folding procedure.

- Increase the pressure setting on S3 by 1/2 turn clockwise. (repeat if required)

- Remove Check-valve C4 or C5 and inspect.

- If oil is flowing through the manifold but no movement is occurring, then it is possible that a piston seal has failed. Sequentially isolate cylinders until culprit is identified. (Fold wings to transport position before removing cylinders, DEATH or INJURY could result.)

- Check that tractor hydraulic oil pressure is adequate (2200psi / 151Bar).



Sequence valve adjustments

RIGHT WING RISES BUT LEFT WING WON'T RISE

If the pressure required to raise the left wing is greater than tractor pressure then oil will not flow. This may occur if chain is full of mud or other matter increasing the weight of the chain. It may also occur on tractors with lower than original hydraulic oil pressure. Left wing is longer than right wing and may require more pressure to lift.

If the pressure setting of S3 is too high then oil will stall and left wing will not raise.

Disc chain may be caught on one of the saddles or supports, especially on the rear "M" bracket mounts, preventing the wing from lifting.

Oil may bypass a cylinder piston seal if the seal or piston have failed. You will hear oil flowing in one cylinder and that cylinder should warm up compared to the remaining cylinders.

A check-valve may be stuck open allowing oil to bypass.

Solution

Clean chains of mud and debris.

Check the disc chain for areas it might be caught and make adjustments to support brackets or folding procedure.

Decrease the pressure setting on S3 by 1/2 turn clockwise. (repeat if required)

Remove and inspect check-valve C4. Clear any contamination and reinstall.

If oil is flowing through the manifold but no movement is occurring, then it is possible that a piston seal has failed. Sequentially isolate cylinders until culprit is identified. (Fold wings to transport position before removing cylinders, DEATH or INJURY could result.)

Check that tractor hydraulic oil pressure is adequate (2200psi / 151Bar).

CENTER CYLINDERS EXTEND BEFORE OUTER WINGS ARE BOTH STRAIGHT (VERTICAL)

If the pressure required to raise the right wing is greater than that set by S3 then oil will flow past S3 to the left wing. As the right wing rests on top of the left wing and neither can move then oil is also forced past S4 to the main wing cylinders causing them to extend while the outer wings are still folded. As the main wings unfold and the weight is transferred from the outer wings then the oil will flow to the outer wing cylinders allowing the wings to straighten. Do not allow this to continue as the cylinder pins will shear and the wings will fall uncontrolled.

The same symptom will occur if check valve C4 is held open by contamination.

As above, mud or debris in the chain will change the load and operating pressure required to lift the outer wings.

Solution

If chains are clean then increase the pressure setting on S3. (right wing will raise)

Increase pressure setting on S4 (left wing will raise)

Remove and inspect Check valve C4. Clear any foreign material from around ball & seat area.



Sequence valve adjustments

BOTH WINGS STAND VERTICAL THEN STOP

Once the outer wings have stood vertical oil pressure opens S4 and allows flow to the main wing cylinders. An overcentre valve, L1 prevents the wings from falling and controls their decent to working position.

Solution

- Lower pressure setting on S4, screw centre counterclockwise 1/2 turn, check, repeat if needed.
- L1 overcentre valve may be set too high, preventing return oil flowing to tank. Reduce pressure setting on L1 by turning CLOCKWISE 1 turn.
- Check that hydraulic flow on the tractor is not set to very low or off.
- Check tractor hydraulic pressure (should exceed 2200 psi -151 Bar).
- Call service technician. Test for oil flow. If flow is present isolate cylinders one at a time to ensure integrity of cylinder piston seal. (Fold wings to transport position before removing cylinders, DEATH or INJURY could result.).

NO MOVEMENT AT ALL

Solution

- See first point. Check and if necessary clean chains of mud or debris.
- Check that hose tips are correctly engaged in tractor breakaway sockets.
- Check that any taps or electronic transport locks are open on the tractor.
- Check that hydraulic flow on the tractor is not set to very low or off.
- Check tractor hydraulic pressure (should exceed 2200 psi -151 Bar).
- Call service technician. Test for oil flow. If flow is present isolate cylinders one at a time to ensure integrity of cylinder piston seal.

SEQUENCE WAS WORKING BUT HAS BECOME ERRATIC

The sequence valve manifold has an oil flow capacity of 8 gallons (US) per minute (30Lpm). At this flow the sequence cartridges are able to cope with the flow of oil and operate at their correct settings. If the flow rate is set too high, pressure in the manifold builds up and may unseat the sequence valves prematurely or in an unpredictable manner.

Solution

- Set tractor hydraulic remote oil flows to slow (20%).
- Engage tractor hydraulic lever slowly.
- Reduce flow by screwing flow control valve E counterclockwise 2 turns.



Sequence valve adjustments

Folding

The fold sequence is as follows.

1. Raise tail and modules
2. Raise wings until fully folded
3. Raise tongue assembly to transport height.

During folding, oil travels directly to the main wing cylinders. When these are all closed oil then opens S1 allowing oil to flow to the left outer wing cylinders. When these cylinders close oil pressure opens S2 to fold the right outer wing.

NO MOVEMENT AT ALL

The main cylinders are the first to receive oil from tractor and should lift the wings. Failure to operate as expected could indicate excess mud in the discs. If the tail has not been raised it is possible that the wings will not lift up as the chain tension prevents them from rising.

Solution

- Clean mud from the discs.
- Raise the tail section fully prior to folding the wings.

BOTH MAIN WINGS STAND VERTICAL THEN LEFT WING WON'T FOLD.

Oil flows straight from tractor to the main cylinders. Once raised oil must then force S1 open to allow flow to the left outer wing. If S1 is set too high then oil flow will stall and the left outer wing will not fold.

Over centre valve L4 is used to hold the left wing straight during operation. If L4 is set at too high a pressure the left wing will not fold. L4 is a pilot operated valve and requires correct system pressure to function.

A pressure control valve, PL (7.2) is used to protect the frame in the event that wings collide when folding. If the pressure setting on PL is too low then there will be insufficient pilot pressure to operate L4 valve. Before adjusting L4 ensure that PL is set correctly.

Solution

- Reduce the pressure setting on S1 by screwing counterclockwise 1/2 turn. (repeat as required.)
- Increase pressure setting on PL (7.2) by screwing clockwise 2 turns.
- Reduce pressure setting on L4 by screwing CLOCKWISE 1 turn.



Sequence valve adjustments

LEFT HAND OUTER WING FOLDS BEFORE BOTH INNER WINGS ARE VERTICAL

If the pressure required to raise the wings to vertical is greater than the pressure setting on S1 then oil will pass S1 and cause the left hand outer wing cylinders to retract. This may occur if there is excessive load such as mud or debris or on occasions where the chains may have become blocked and buried.

The same symptom can be seen if check-valve C3 is held open by contamination.

Solution

Check and clean if necessary any mud or debris from chains. Do not attempt to fold the machine if the chains are buried during a blockage. Clear away the soil from the chains first.

If the chains are clean but problem persists it may be necessary to adjust S1. Increase the pressure setting by screwing clockwise 1/2 turn.

Remove and clean C3 Check-valve.

RIGHT HAND OUTER WING FOLDS BEFORE BOTH INNER WINGS ARE VERTICAL

In the normal folding process the Left wing must fold before the Right wing. Even if both S1 and S2 have pressure settings that are too low, then both wings will move together. For the Right outer wing to move first then Check-valve C1 must be open.

Solution

Remove and clean C1 check-valve.



Sequence valve adjustments

MAIN WINGS FOLD, LEFT OUTER WING FOLDS THEN RIGHT OUTER WING STANDS VERTICAL.

Oil is forced to the Left outer wing cylinders which cause the left wing to fold down. Once these cylinders are closed oil pressure increases and opens S2 allowing oil to flow to the right hand outer wing cylinders. If S2 is set too high the oil flow can stall after left outer wing is folded.

Over centre valve L3 is used to hold the right wing straight during operation. If pressure setting on L3 is too high the left wing will not fold. L3 is a pilot operated valve and requires correct system pressure to function.

A pressure control valve, PR is used to protect the frame in the event that wings collide when folding. If the pressure setting on PR is too low then there will be insufficient pilot pressure to operate L3 valve. Before adjusting L3 ensure that PL is set correctly.

Solution

Reduce the pressure setting on S2 by screwing counterclockwise 1/2 turn. (repeat as required.)

Increase pressure setting on PR by screwing clockwise 2 turns.

Reduce pressure setting on L3 by screwing CLOCKWISE 1 turn.

OUTER WINGS COLLIDE WHEN FOLDING.

If you witness the two outer wings coming together when folding you must immediately stop and reverse the operation. Unfold the wings to vertical then recommence slowly. The individual wings should fold in sequence. If they both continue to fold together then oil must be passing S2 prematurely. For this to happen S2 has pressure set too low.

Solution

Increase the pressure setting on S2 by screwing clockwise 1/2 turn. (repeat as required.)

Sequence valve adjustments

LEFT OUTER WING STANDS VERTICAL AND RIGHT OUTER WING FOLDS OVER

The main wings stand vertical then the left wing does not move but the right hand outer wing folds over then all movement stops. This can occur when the L4 overcentre valve that holds the wing straight during operation in the field, will not release and allow the wing to fold. L4 could be contaminated but would usually stick open. L4 could have failed but this is rare. PL may be set at a pressure too low to activate the pilot release on L4.

Solution

Increase the pressure setting on PL by screwing it clockwise 2 turns.

Decrease the pressure setting on L4 by screwing it CLOCKWISE 1/2 turn.

SEQUENCE WAS WORKING FINE BUT HAS BECOME ERRATIC

The sequence valve manifold has an oil flow capacity of 8 gallons (US) per minute. (30Lpm).

At this flow the sequence cartridges are able to cope with the flow of oil and operate at their correct settings. If the flow rate is set too high, pressure in the manifold builds up and may unseat the sequence valves prematurely or in an unpredictable manner.

Occasionally foreign material may lodge in one of the check valves. This will allow oil to flow in a seemingly illogical manner. Symptoms suggest valve adjustments however the logical adjustments have no effect.

Solution

Set tractor hydraulic remote oil flows to slow (20%).

Engage tractor hydraulic lever slowly.

Reduce flow by screwing flow control valve R counterclockwise 2 turns.

NO MOVEMENT AT ALL

Solution

Check that hose tips are correctly engaged in tractor breakaway sockets.

Check that any shut off valves or electronic transport locks are open on the tractor.

Check that hydraulic flow on the tractor is not set to very low or off.

Check tractor hydraulic pressure (should exceed 2200psi - 151 Bar).

Call service technician. Test for oil flow. If flow is present isolate cylinders one at a time to ensure integrity of cylinder piston seal.



WORKING

Wings “sag” in middle while working.

Both sets of wings are locked straight in working position by the L4 and L3 over centre valves. If the pressure setting on these valves is too low the wings may not be effectively locked.

Solution

Left wing sagging, increase the pressure setting on L4 by screwing it COUNTERCLOCKWISE 1/2 turn.

Right wing sagging, increase the pressure setting on L3 by screwing it COUNTERCLOCKWISE 1/2 turn.

IF THESE ADJUSTMENTS DO NOT SOLVE THE PROBLEM

Contact your service agent for assistance. There may be a fault with one of the cartridges.

The valve manifolds are tested at factory and again prior to shipping. The assembling agent will also have ensured the correct operation prior to delivery. Very rarely, but occasionally valves do fail. The usual cause is ingress of contaminant.

You may also contact Kelly Engineering for technical advice and assistance.

International : 011 618 8667 2253

USA: 417-865-2100

Canada: 306-213-6675

From within Australia: 08 8667 2253

Location No.	Part No.	Location Table
1.1 - 1.4	PSVP-10-N-S-0-30	
2	FR12-23A-0-N/M23	
3	FR12-23A-0-N/M32	
4.1, 4.2	6114063 - CBCA-LHN	
5.1, 5.2	6114056 - CBCG-LJN	
6	CBCL-LJN	
7.1 - 7.4	CV10-20-0-N-5	
8.1, 8.2	PR10-36A-0-N-30	
9	410021 (5116" UNF PLUG)	

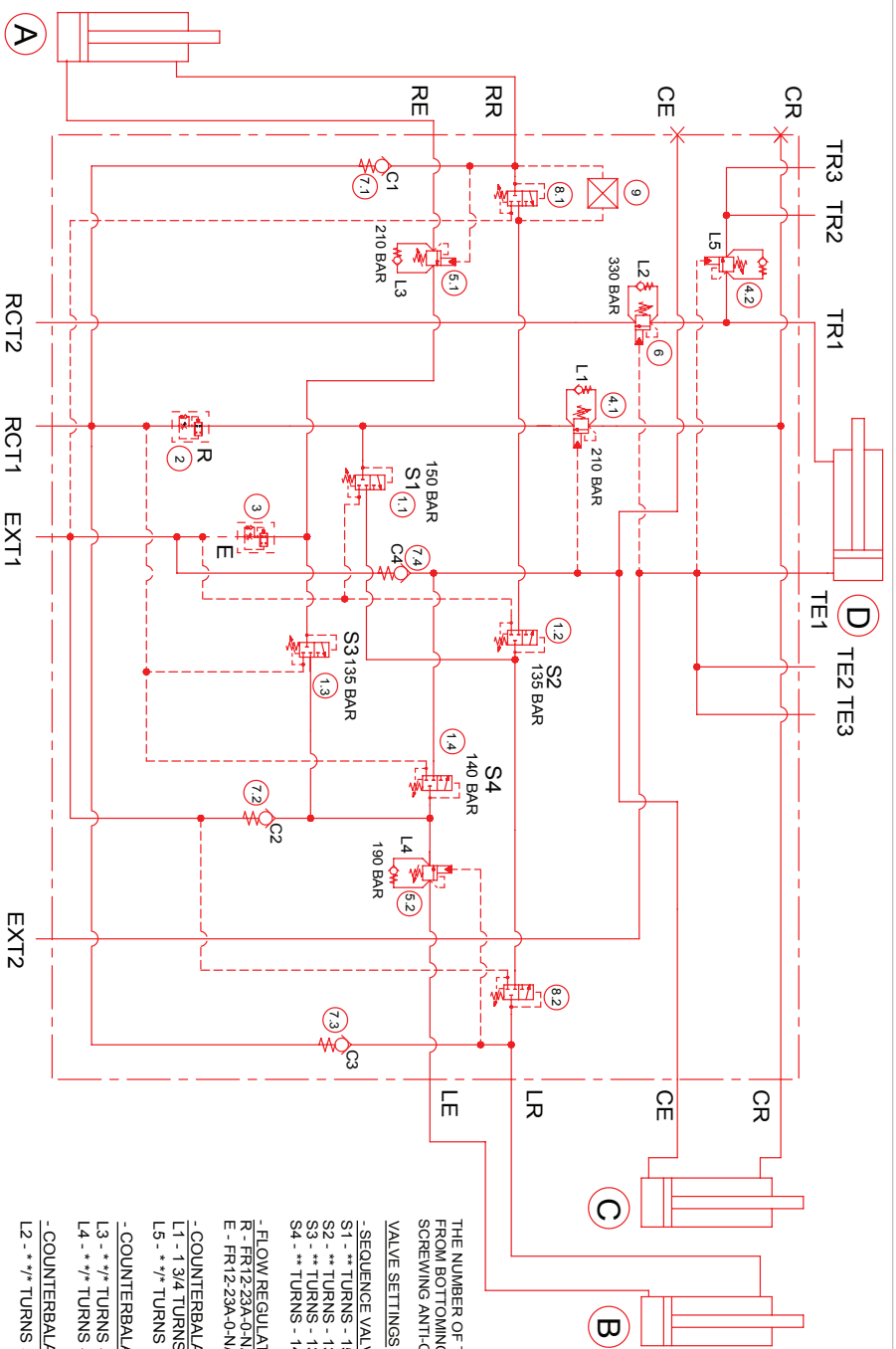

THE NUMBER OF TURNS IS MEASURED FROM BOTTOMING THE VALVE OUT AND SCREWING ANTI-CLOCKWISE.

VALVE SETTINGS

- SEQUENCE VALVES -PSVP-10-N-S-0-30"
- S1 - ** TURNS - 150 BAR
- S2 - ** TURNS - 135 BAR
- S3 - ** TURNS - 135 BAR
- S4 - ** TURNS - 140 BAR
- FLOW REGULATOR FR12-23A-0-N
- R - FR12-23A-0-N/M23
- E - FR12-23A-0-N/M32
- COUNTERBALANCE VALVES 6114063
- L1 - 1 3/4 TURNS 210 BAR
- L2 - ** TURNS - ** BAR
- L3 - ** TURNS - 210 BAR
- L4 - ** TURNS - 190 BAR
- COUNTERBALANCE VALVE CBCL-LJN
- L2 - ** TURNS 330 BAR
- 8.1, 8.2
- PR10-36A-0-N-30
- CHECK VALVES CV10-20-0-N-5
- CHECKS LOCATED AT C1 - C4



21 DELORAINE ROAD,
EDWARDSTOWN S.A. 5039
www.oilpathydraulics.com.au

PH: +61 8 8277 4933 FAX: +61 8 8277 9126 A.B.N. 94 117 925 210

- NOTES**
- ALL DIMENSIONS IN mm
 - ALL DRILL DEPTHS TO SHOULDER
 - BREAK ALL SHARP EDGES
 - GOLD ANODISE

- GENERAL TOLERANCE**
- 0. = ±0.5 mm
 - 0.0 = ±0.25 mm
 - 0.00 = ±0.10 mm
 - 0.000 = ±0.02 mm

UNLESS OTHERWISE STATED

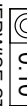

SCALE:1:4 SHEET 2 OF 2

REVISION DETAILS

ECN	DATE	DESCRIPTION

TITLE
KELLY 3 STAGE PRICKLECHAIN
SEQUENCE MANIFOLD V9

DRG NO.
690430

MATL: Alloy 6061-T6

DRN: C. Bonham

DATE: 28/08/2013

REV **A4**

CD: APP:

DATE:

