



Kelly Tillage System 6m

Operating Instruction Manual

Serial number:



Register within 2 months of purchasing the machine to receive an additional 12 months warranty.

Find the registration information on page 12

Revision D

Kelly Engineering
PO Box 100
Booleroo Centre
South Australia 5482

Email: sales@kellytillage.com
Website: www.kellytillage.com

Contents

	Page no
Safety Information	3
Signal words	4
Safety guidelines	4
General operation	5
Transport	5
Hydraulics	5
Maintenance & inspection	5
Safety decals - individual placement	6 to 9
Section 1 - Warranty	10
Warranty policy	11
Product registration form	12
Thank-you for choosing a Kelly	13
Contact information	13
Section 2 - Machine Operation	14
Before operation	15
Pre-operation checklist	15
Park brake	16
Brake setup	17
Basic unfolding operation	18 to 20
Basic folding operation	21 to 24
Section 3 - Chain Operation & Correct Setup	25
Importance of chain tension	26
Frame height adjustment	26
Machine setup prior to operating	27
Set chain tension	28 to 29
Correct hydraulic chain tensioning	30 to 31
Dropleg height adjustment	32 to 33
Fine adjustment for perfect operating results	34 to 35
Section 4 - Maintenance & Inspection	36
Maintenance and inspection	37
Intervals	37 to 38
Trouble shooting	38 to 39
Section 5 - Specifications	40
Operating speed	41
Tyre pressure	41
Disc chain lengths and quantities	41
Bolt torque settings	42
Notes	43



Read all assembly instructions and study all photographs thoroughly before assembling the unit

Please note:

Left and right is determined by standing behind the machine and looking to the front.



Signal Words

A signal word - **DANGER**, **WARNING**, or **CAUTION**, is used with the safety alert symbol.

When you see this symbol on your machine or in this manual, be alert to instructions involving your personal safety and the safety of others.

Failure to follow these instructions can result in injury or death.



DANGER - Indicates an immediate hazardous situation that, if not avoided, will result in **DEATH OR SERIOUS INJURY**.



WARNING - Indicates a potentially hazardous situation that, if not avoided, could result in **DEATH OR SERIOUS INJURY**.



CAUTION - Indicates a potentially hazardous situation that, if not avoided, may result in a **MINOR OR MODERATE INJURY**.

Carefully read all safety points in this manual and on your machine. Keep all safety decals in good condition and replace ones that have been worn or lost. Replacement decals are available by contacting your local dealer.

Safety guidelines

- This equipment is dangerous to persons unfamiliar with its operation.
- Do not allow persons to operate or assemble this unit until they have read this manual and have developed a thorough understanding of the safety precautions.
- Do not attempt to operate this equipment under the influence of drugs or alcohol.
- Review the safety instructions with all users annually.

General operation

- Proceed cautiously under overhead powerlines and around power poles, as contact may result in the operator suffering a severe electrical shock.
- Never allow anyone within the immediate area when operating machinery.
- Stand clear when raising or lowering wings.

Transporting

- Always travel at a safe speed. **NEVER EXCEED 25kph.**
- Ensure transporting transport safety lock valves are closed during transport to ensure machine is transported safely (Fig.13 & 14).
- Ensure your speed is low enough for an emergency stop to be safe and secure and reduce speed prior to turns.
- Ensure safety chain is attached correctly to the towing vehicle.
- Please refer to your own country, state, provincial, county or municipality laws on the rules of transporting farm machinery on roads.
- Ensure that disc or prickly chains are engaged in chain guides and supports. Disc or prickly chain should be clear of the ground.
- Be aware of the height, length and width of the machine. Beware of obstacles and overhead powerlines.
- Use approved accessory and necessary warning devices on the road during both day and night time transporting.

Hydraulics

- **NEVER** remove hydraulic hoses or ends unless the machine is in either transport position or fully extended in working position. Relieve all hydraulic pressure before disconnecting hydraulic hoses and fittings.
- Ensure all fittings and hoses are in good condition.
- Do not search for high pressure hydraulic leaks without hand and face protection. A leak can penetrate the skin, thereby requiring immediate medical attention.
- Double check that all is clear before operating hydraulics.
- Maintain proper hydraulic fluid levels and pressure.

Maintenance and inspection

- Good maintenance is your responsibility.
- Regular maintenance and inspection is imperative.

Maintenance guidelines can be found in section 4



If any safety decals are missing please contact your local dealer immediately and do not use the machine

Safety decals - individual placement

Fig 1.

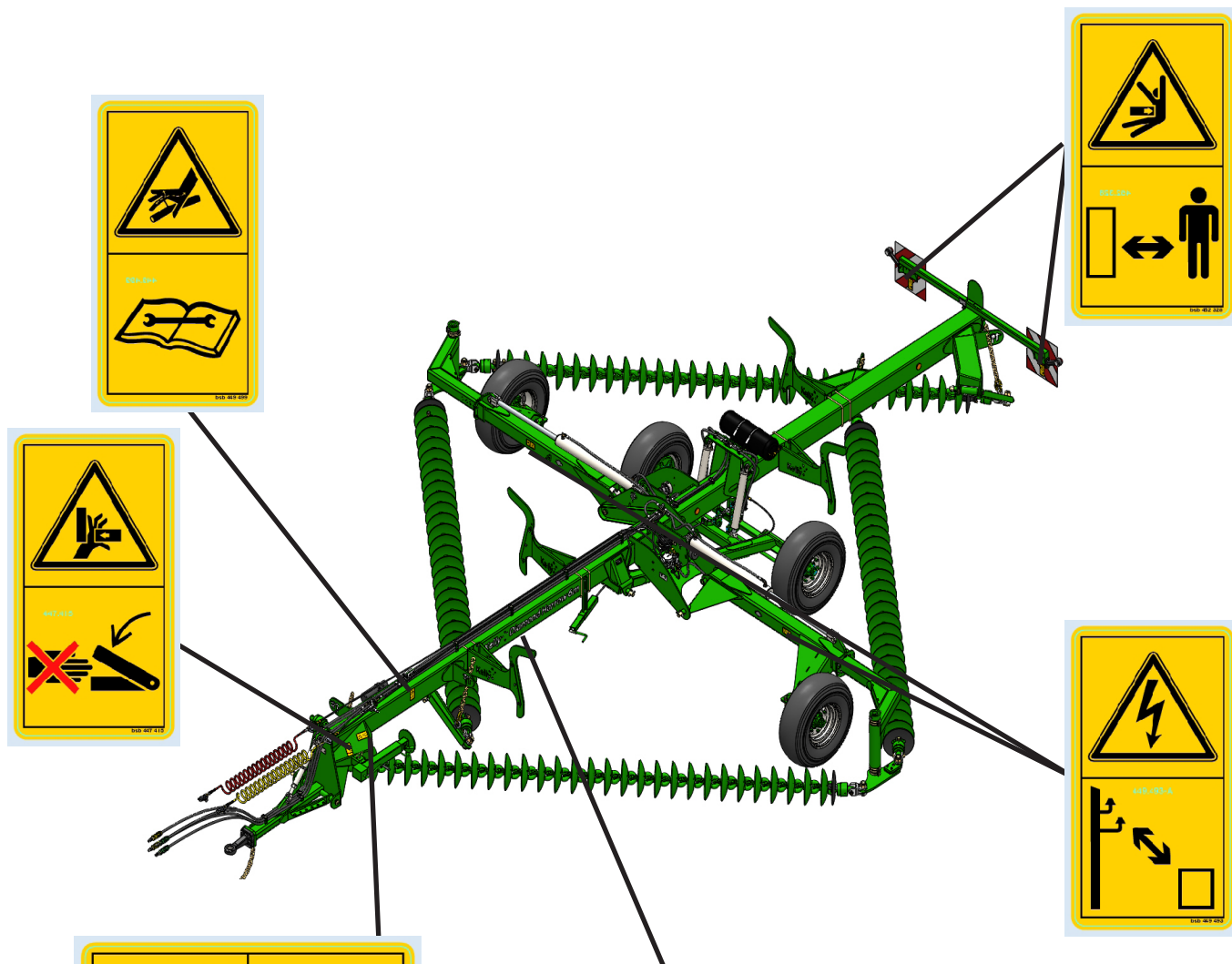

Kelly *Diamond Harrow 6m*

Fig 2.

Kelly	Kelly Engineering Booloroo Centre South Australia 5482	CE
Bezeichnung / Designation		
Marke / Brand		
Modell / Model		
Serien Nr. / Machine ID (FIN/VIN)	W09KYE14SJSMA4001	
Typ / Type		
Kelly serial number		
Baujahr / Production year	2018	Achslast / Axle load
Max. Stützlast / Max hitch load	kg	1. kg
zul. Gesamtgewicht / Max mass	kg	2. kg
Leergewicht / Max unloaded		3. kg
Achslast gesamt / Total axle load		
Manufactured by MAFA Stolpen GmbH		

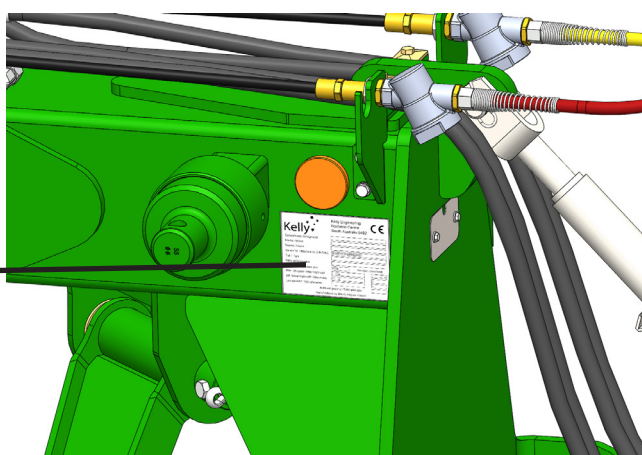

If any safety decals are missing please contact your local dealer immediately and do not use the machine

Safety decals - individual placement

Fig 3.

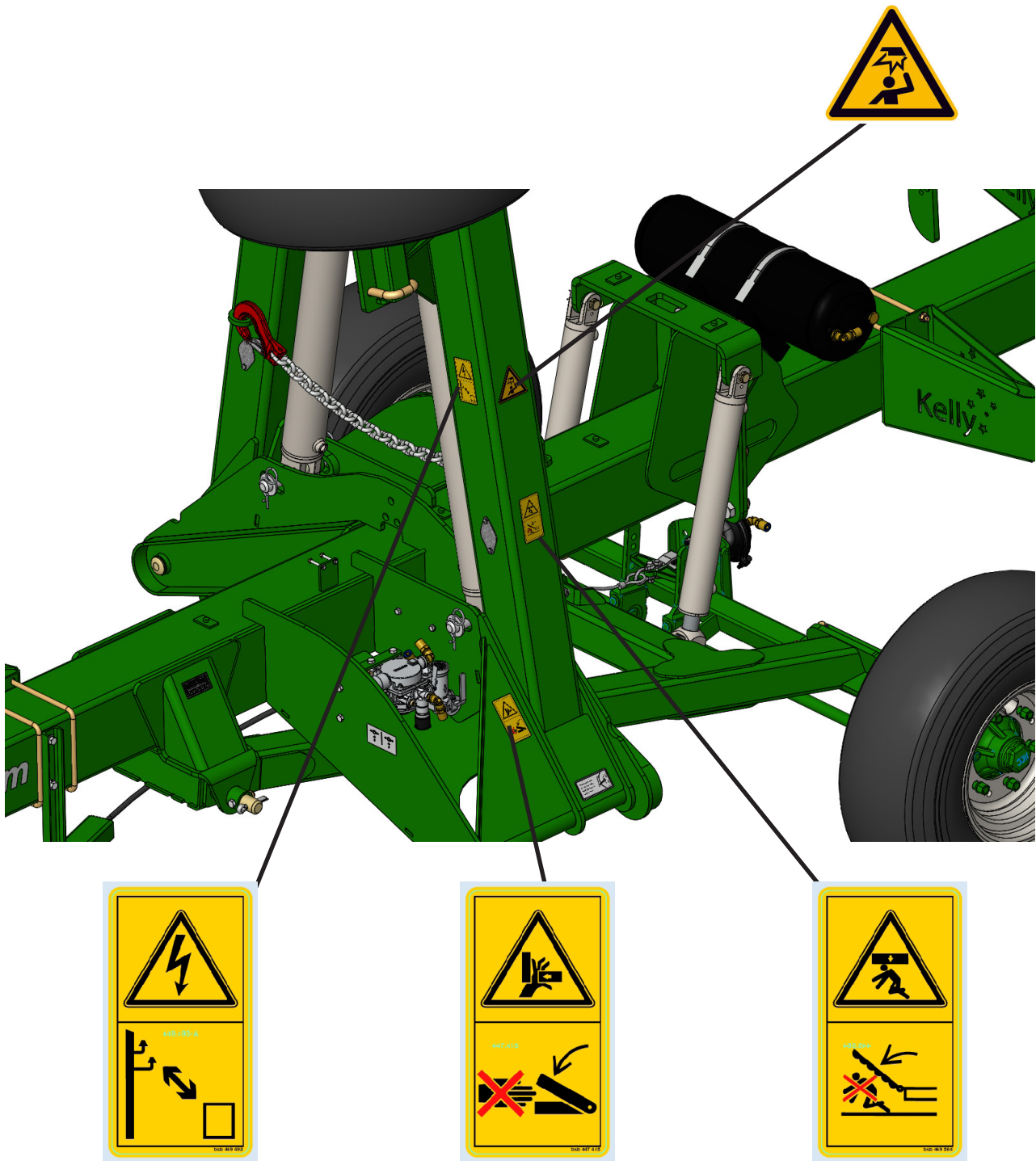

If any safety decals are missing please contact your local dealer immediately and do not use the machine

Safety decals - individual placement

Fig 4.

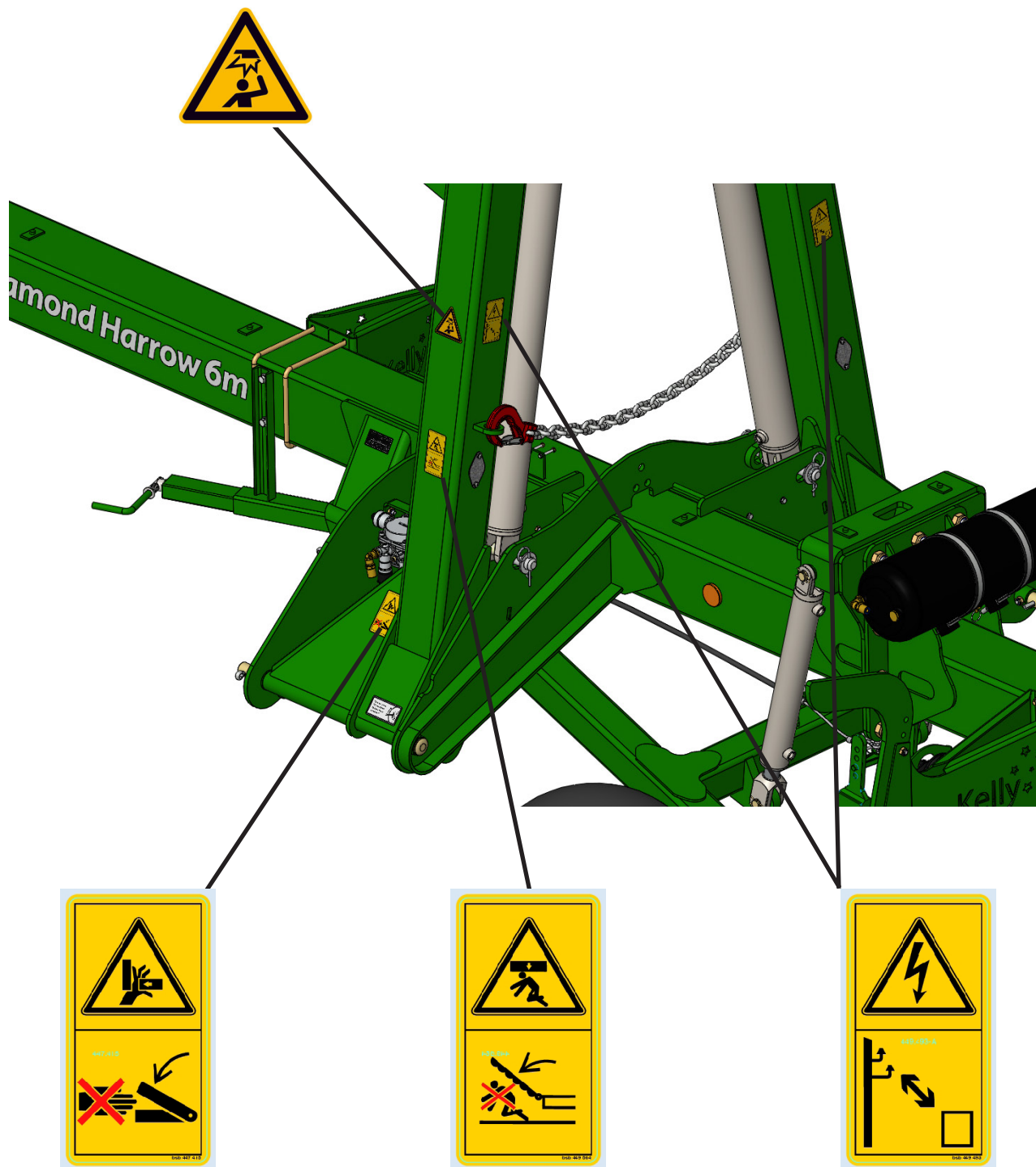

If any safety decals are missing please contact your local dealer immediately and do not use the machine

Safety decals - individual placement

Orange reflectors - quantity: 8

Locate facing outwards on central section
Facing forward on outer face of chain catch

Orange reflectors

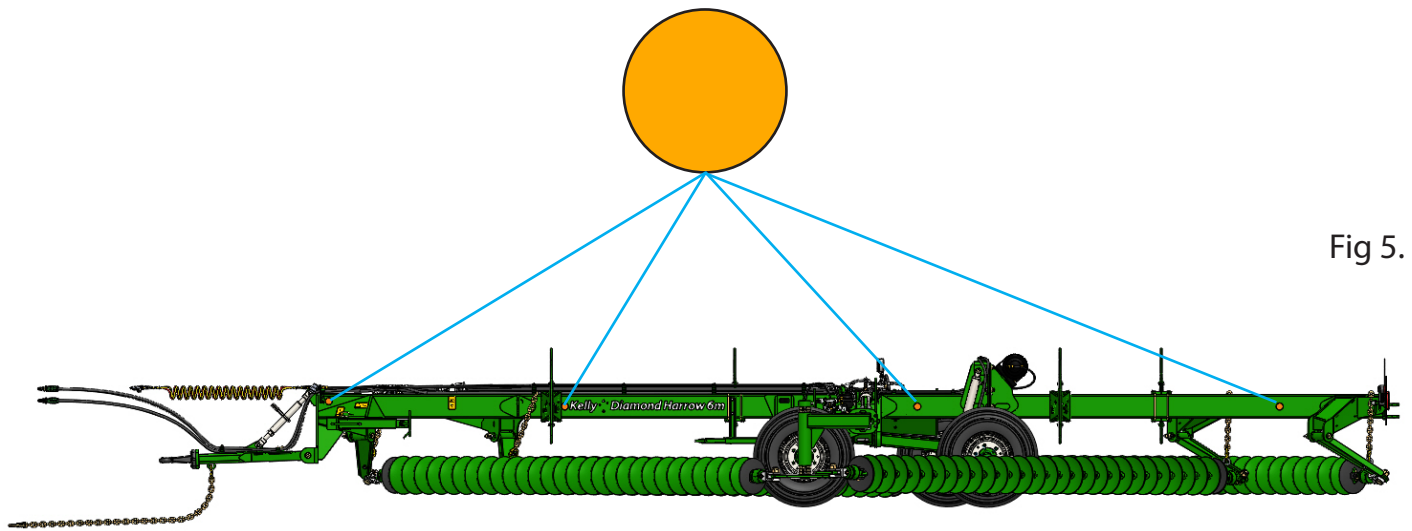
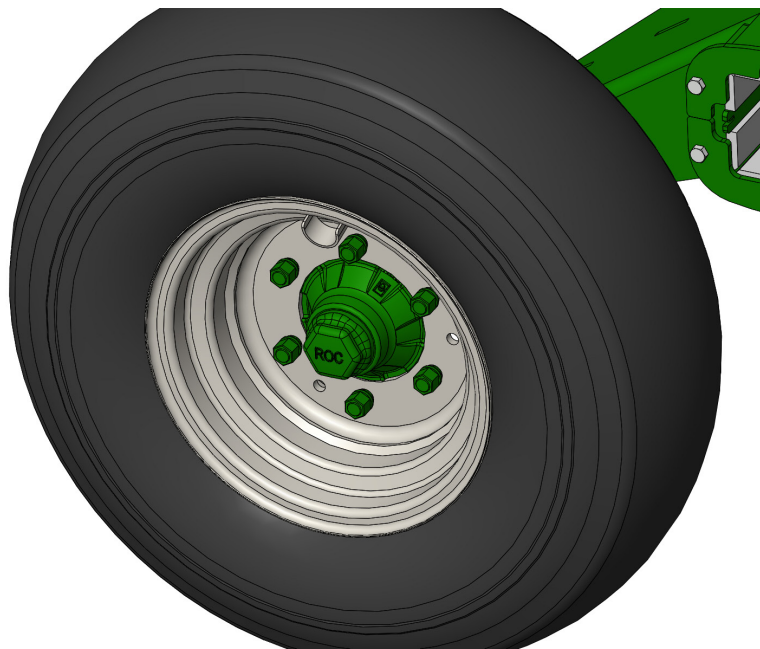

Fig 5.

Fig 6.



**CHECK WHEEL NUTS
AFTER FIRST .5 HRS
AND AT REGULAR INTERVALS**



If any safety decals are missing please contact your local dealer immediately and do not use the machine

Section 1

Warranty

Warranty Policy

The warranty for the machine will be null and void if any non-genuine Kelly part is used on the machine.

Subject to the dealer ensuring that the machine is in correct working order and setup, in accordance with the assembly and operating manuals, at the time of delivery to the purchaser, Kelly guarantees its products against faulty workmanship and materials for twelve (12) months from date of delivery.

Ground engaging tools are warranted against faulty material and workmanship for 20 000 hectares. Replaceable cutting disc blades are warranted against faulty materials and workmanship only. All other ground engaging tools carry a 20 000 hectare wear warranty.

Kelly offers an additional 12-month warranty to the dealer if the machine is registered within 2 months from the date of delivery. Machine registrations can be completed by the purchaser or dealer on the Kelly website or the Kelly supplied warranty registration form in the operator manual.

Kelly's warranty policy does not cover incorrect assembly after handover to the purchaser, misuse, modifications, damage during transit or product that has not been maintained per the Kelly maintenance procedures outlined in the relevant product manual. Failure to properly maintain the machine or blatant misuse shall result in the warranty being null and void.

All warranty claims from the purchaser must be made through the dealer, who in turn, will make a reciprocal claim on Kelly. Kelly will reimburse the dealer for any claims it approves who, in turn, will reimburse the purchaser.

Kelly reserves the right to request written, photographic or video documentation of the actual defect or failure prior to any warranty authorisation. All warranty queries and requests for authorisation can be directed to warranty@kellytillage.com

Any warranty repair, service or modification to products must be performed by an authorised Kelly repairer and pre-approved by Kelly in writing prior to any work being carried out.

Kelly will issue an "Authorised Returns" notice for any faulty parts to be returned at the request of the company. Failure to do so on request may result in the claim being declined.

Any claim for warranty, labour or parts must be completed on the prescribed warranty claim form found on the Kelly website.

Warranty claims are to be lodged within 30 days of completion of work. If further information is requested on the claim from the Market Liaison Officer, you have 30 days to provide the information. If you fail to adhere with the above instructions the warranty claim may be declined.

Upon completion and approval of this claim the dealer will receive a credit to their account.

Kelly Engineering Product Registration

Register within 2 months of purchasing the machine to receive an additional 12 months warranty

This form must be completed & returned to Kelly, either online, emailed or posted in order to receive the additional 12 months warranty

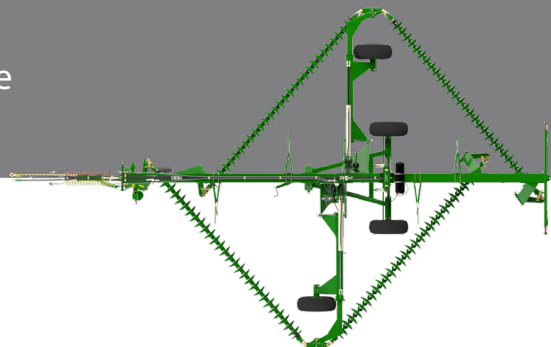

Please return the registration & survey to :

Fill out online

<http://www.kellytillage.com>

Mail to

Kelly
PO Box 100,
Booloroo Centre SA 5482 Australia

Email

sales@kellytillage.com

Purchaser/ owner

Name _____

Address _____

Email address _____

Contact number _____

Purchasing Details

Place of purchase _____ Date of purchase _____

Model purchase _____ Serial number _____

Occupation

Farmer Customer operator Other _____

What brought Kelly Engineering products to your attention ?

Field Day Friend/ neighbor Local Dealer Website
 Dealer Family Radio Referral Source _____
 Demonstration _____ Magazine/ newspaper _____

On a scale of 1 to 10 (10 being highest) how likely are you to recommend us to friends and family ?

1	2	3	4	5	6	7	8	9	10
---	---	---	---	---	---	---	---	---	----

If you scored 8 or below then what must we do to become a 10 in your opinion?

If you scored 9 or above then please tell us why you gave us this score?

Satisfaction with dealer/ agent

Was the machine pre-delivered satisfactorily ? Yes No _____
Were agents well informed about the product ? Yes No _____
Would you recommend the agent to other farmers ? Yes No _____

Thank you for choosing a 6m Kelly Tillage System

We trust that you find the following manual clear and easy to follow. If you should require additional customer support or assistance, please do not hesitate to contact us.

Spare parts can be purchased, as required, through your local dealer or by contacting Kelly.

Kelly welcomes feedback. Should you have any difficulties that you wish to raise, suggestions for improvement or modifications that you feel would enhance our products we look forward to hearing from you.

Contact Information

PO Box 100

Booleroo Centre

South Australia 5482

Phone: + 61 8 8667 2253

Email: sales@kellytillage.com

Spare Parts: parts@kellytillage.com

Website: www.kellytillage.com

Section 2

Machine Operation

Before operation

- Carefully study and understand this manual.
- Do not wear loose fitting clothing that may catch in moving parts.
- Always wear protective clothing and footwear.
- Be sure that there are no tools lying in or on the equipment.
- Do not use the machine until you are sure that the area is clear, particularly of children or animals.
- If this machine is being used in a dry area, or in the presence of combustibles, care should be taken to prevent fires and fire fighting equipment should be readily available.
- Familiarise yourself and other operators with the machine's operation before using.

Pre-operation Checklist

1. All wheel nuts, bolts and nuts are tightened to the correct torque setting
2. Split pins are in place & split
3. Stickers and warning signs are in place
4. Hydraulic fittings are tight and have no leaks
5. Fold machine to ensure chains engage transport rests
6. Check swivel bearings are not seized and still turning freely

Machine set up prior to operating

- Set brake tension on castor wheels to suit ground conditions.
- Compress spring to approx 55-63mm.
(It is usually not necessary to constantly adjust the spring tension. A median setting that accommodates both field and highway use is practical. Make further adjustment if castor wheels oscillate during highway use).

Park brake

Fig 7.

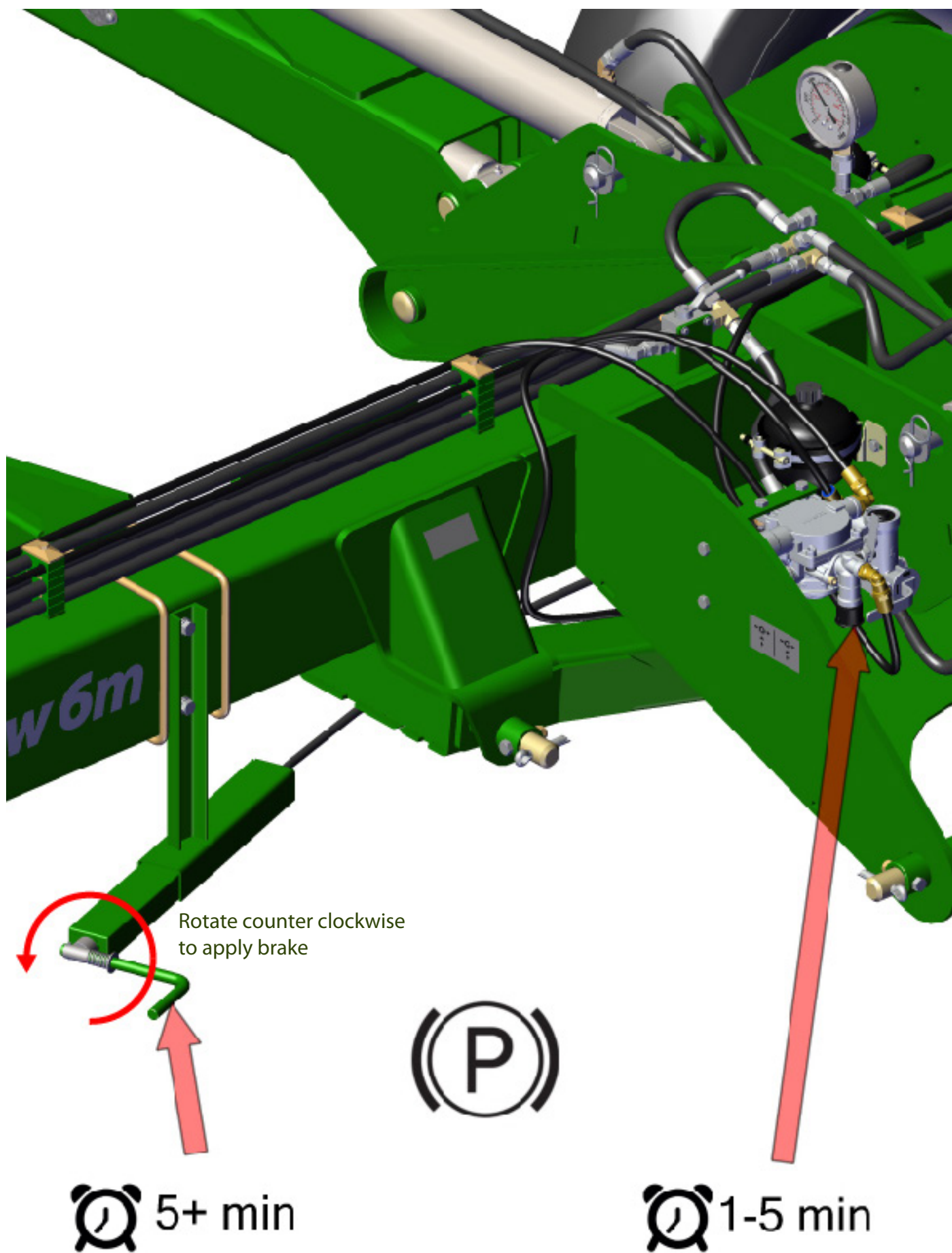

Brake setup

Full load for chain configuration (front/ rear)

(CL2/CL2, CL2/CL1, CL2/SD49, CL1/CL1, CL1/W36, CL1/SD49 SD49/SD49, R300/R300)

Fig 8.

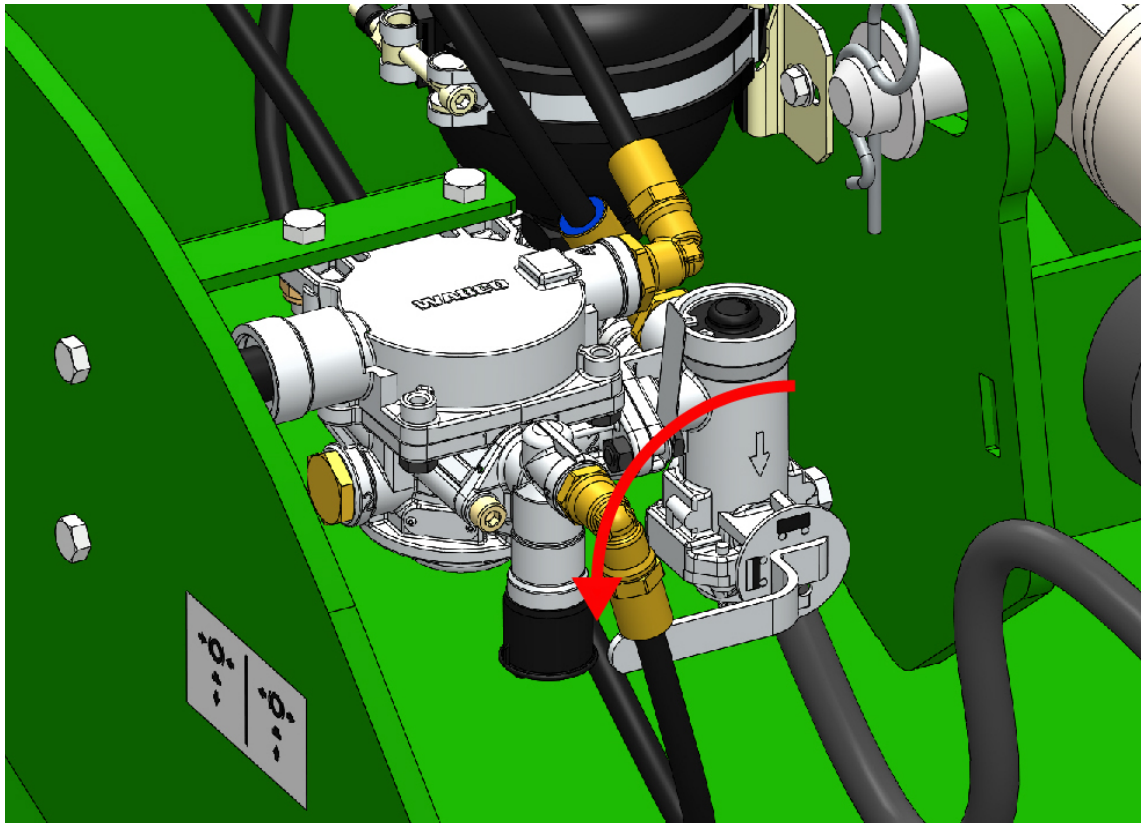

Half load for chain configuration (front/ rear)

(W36/W36, Prickle Chain/ Prickle Chain)

Fig 9.

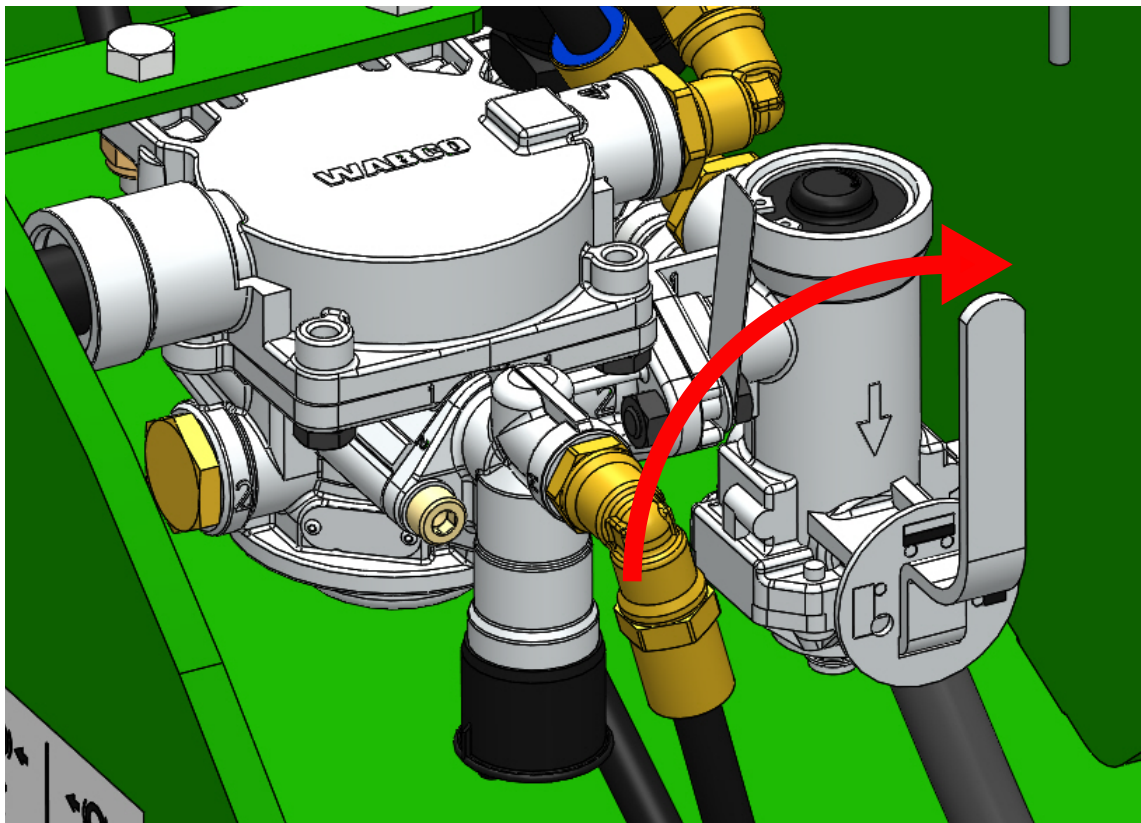

Basic operation

Fig 10.

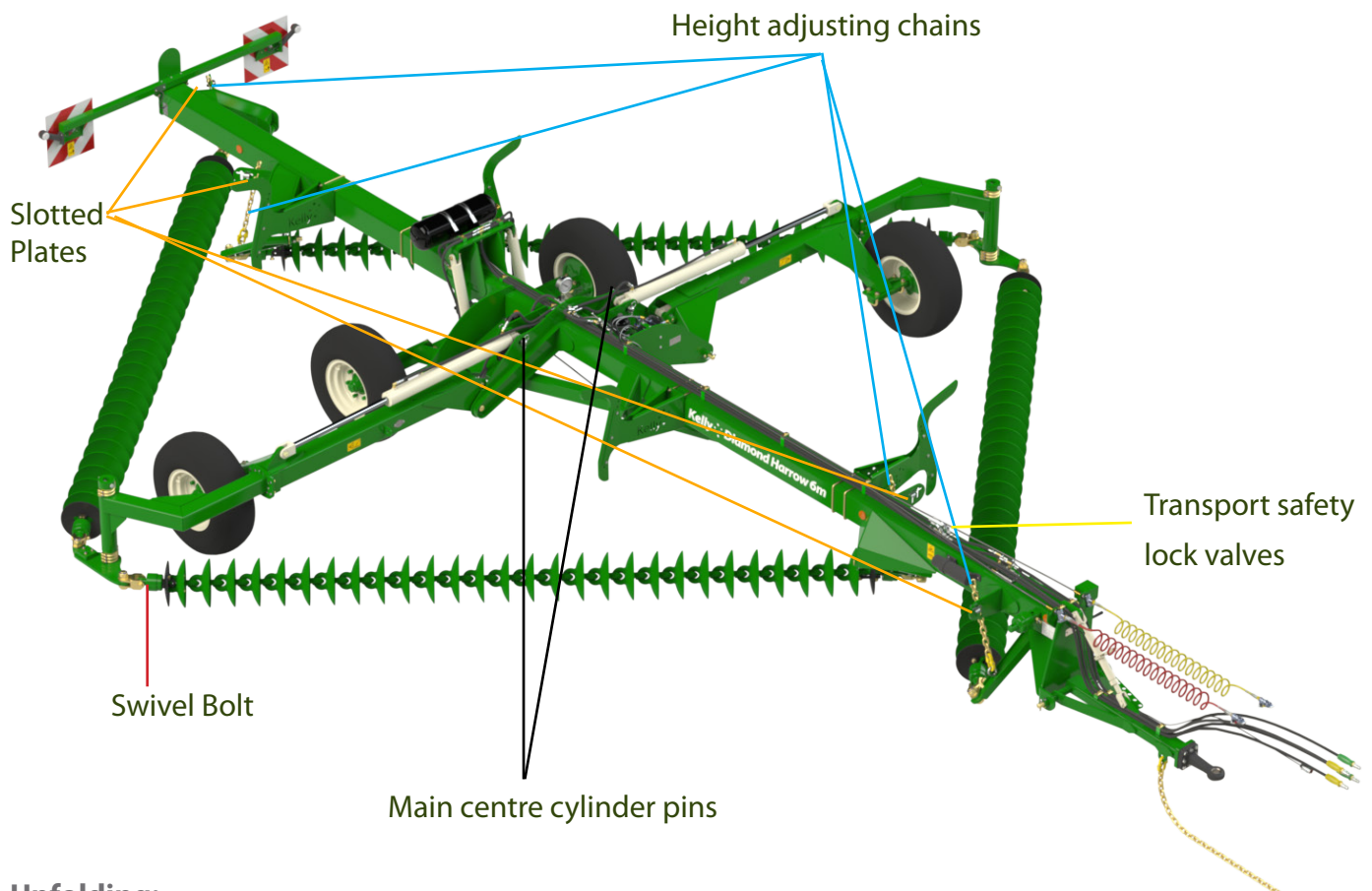

Unfolding:

1. Walk around and inspect the machine.
 - a. Check that chains are not hooked on framework
 - b. Check swivel bolts are in place and not broken
 - c. Check that height adjusting chains have not fallen out of their slotted plates during transport.
2. Open both transport safety lock valves at the front of the machine (see Fig 13 for location of valves)
3. Lower front A frame to working height.
4. Unfold wings, holding the hydraulic lever until the main center cylinder pins have centered in their slots.

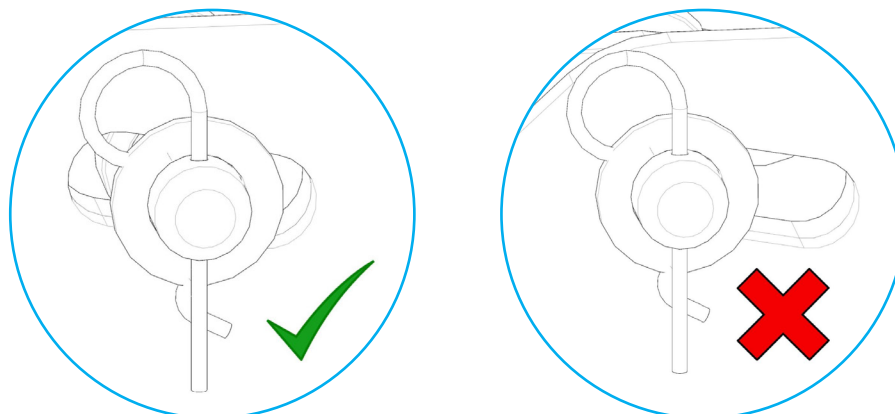
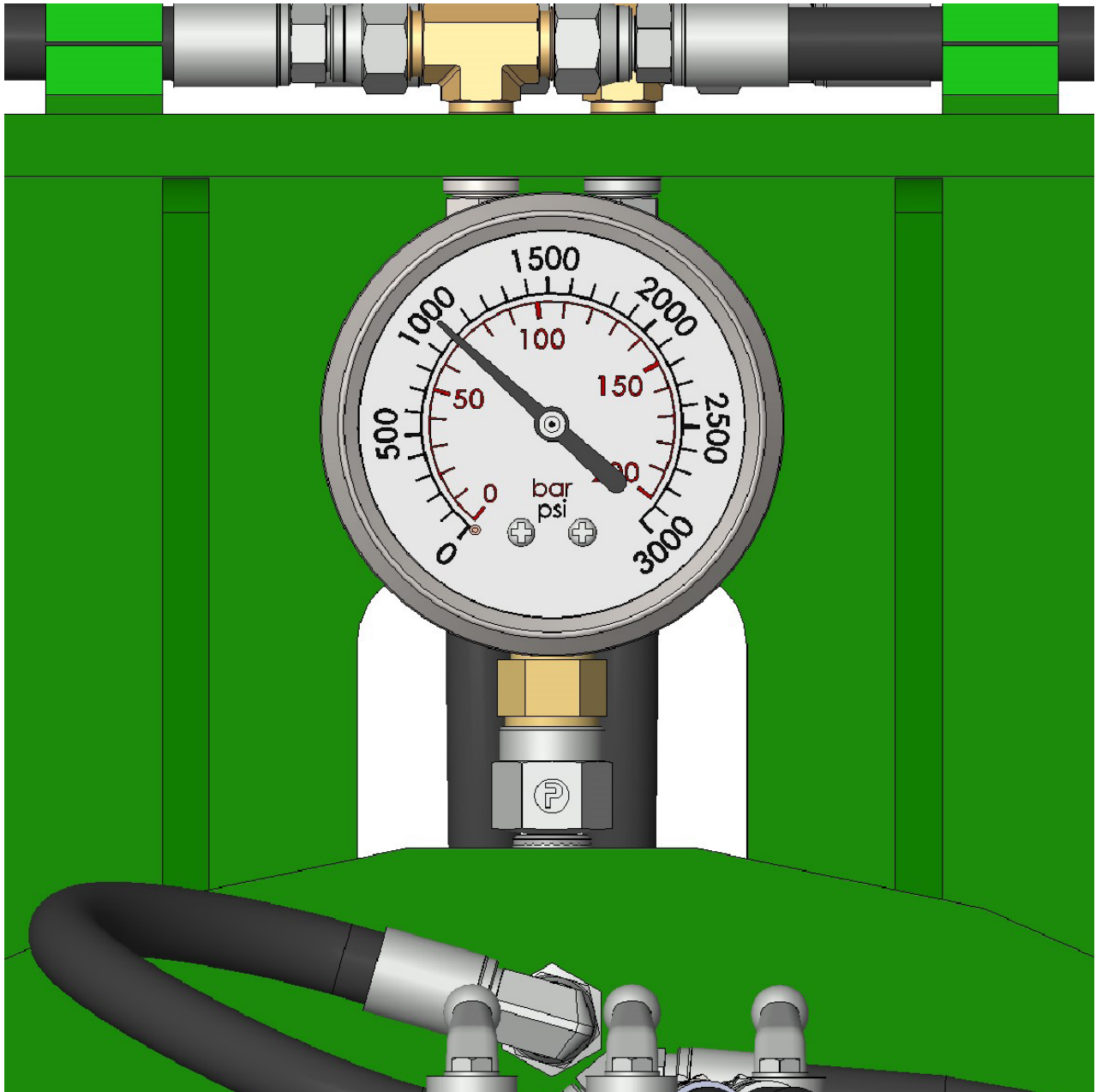

Fig 11.

5. Make sure tap is open and keep holding the pressure on the unfold lever until the tension pressure gauge reads 69 Bar/ 1000 psi. Please note pressure control valve is pre-set to correct pressure.

Fig 12.



The chain is set correctly at 69 Bar/1000 psi

Basic operation

Unfolding:

6. Turn tension isolation valve off (see Fig 14 for location of valve).
7. Walk around and check that all chain links are straight and that working height of all swivels are correct for field conditions. Adjust if necessary, see section frame height adjustment Fig 19.
8. Move off with all chains in working position. If necessary it is acceptable to raise frame to transport height. This will lift the front chains off the ground and reduce the load on the tractor. Lower the frame once operating speed is reached.

Transport safety lock valves

Fig 13.

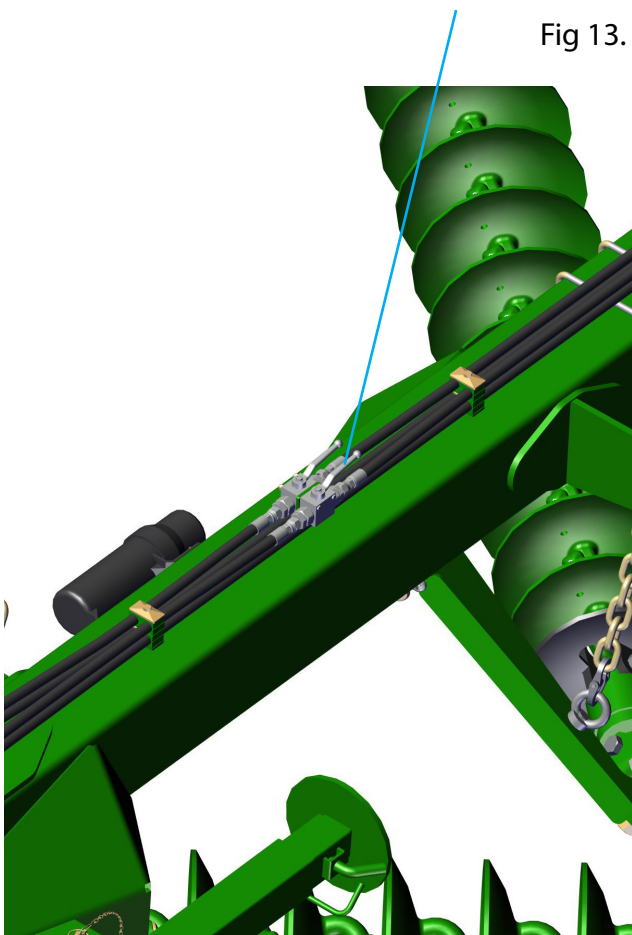

Tension isolation valve

Fig 14.

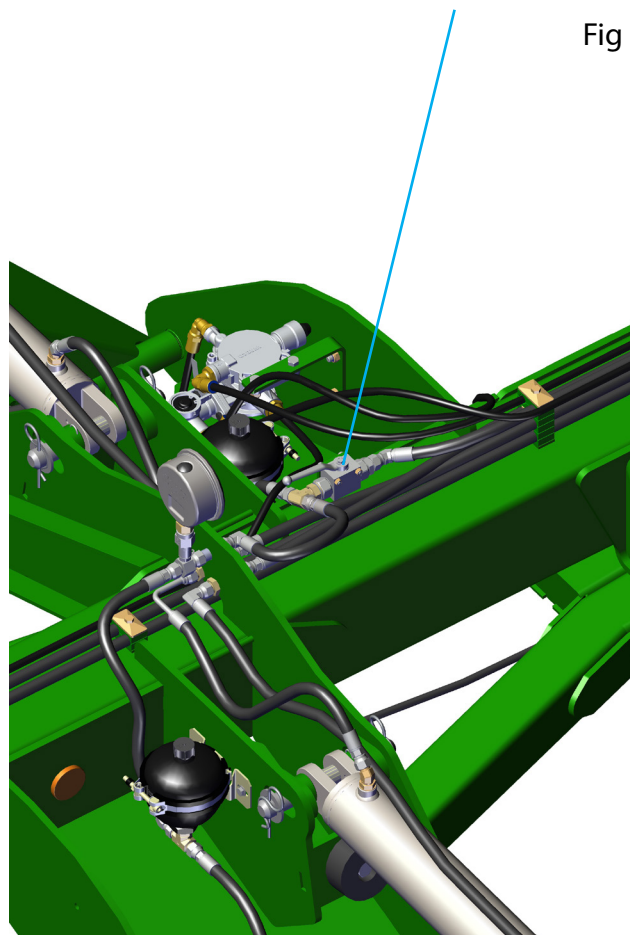

Basic operation

Fig 15.

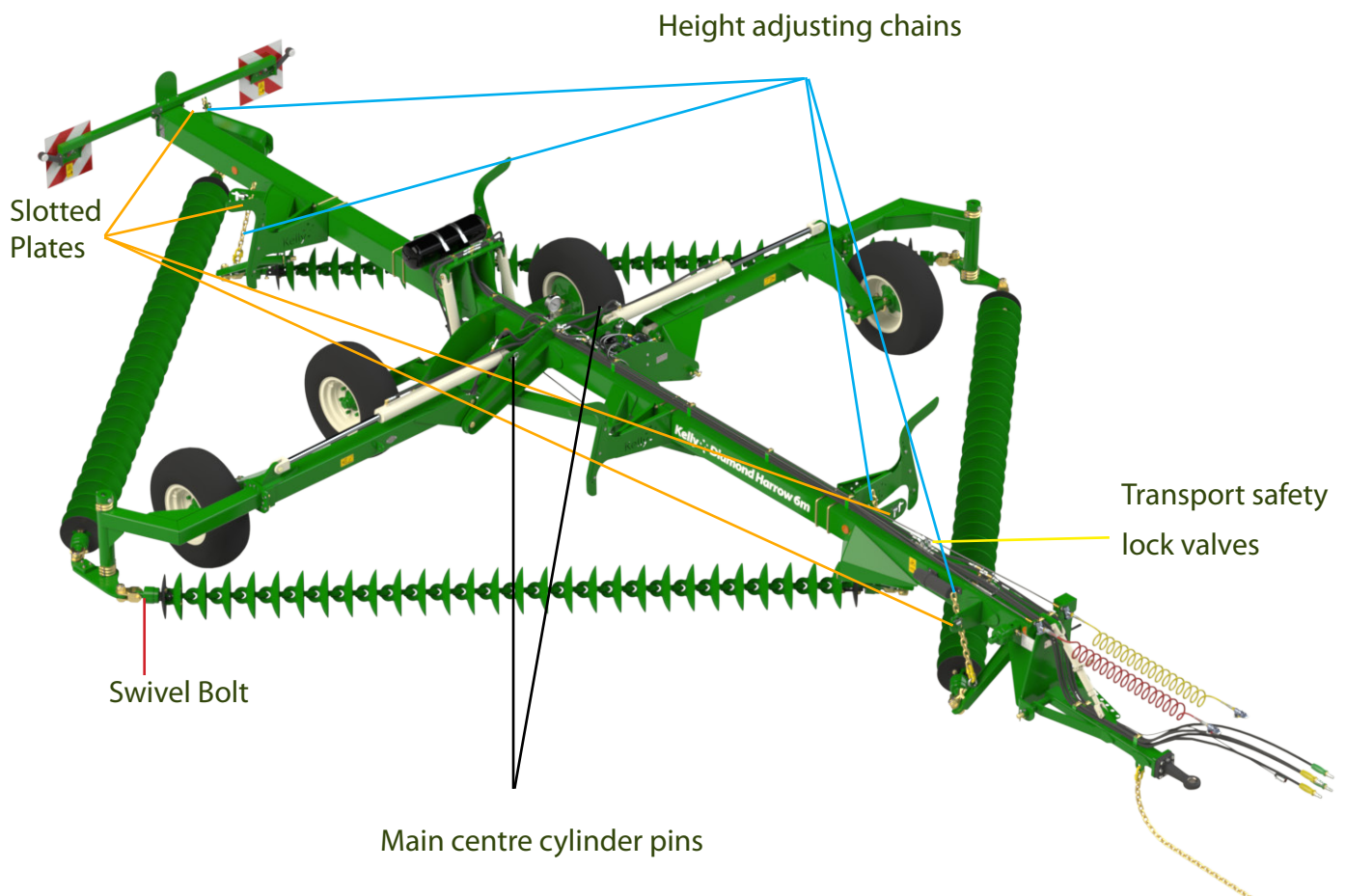

Folding:

1. Walk around and inspect the machine.
 - a. Check swivel bolts are in place and not broken.
 - b. Check that height adjusting chains have not fallen out of their slotted plates during operation.
2. Open wing tension valve. (Fig. 16)
3. Open transport safety lock valves (Fig 13).
4. Fold wings, holding the hydraulic lever until both cylinders are fully retracted.
5. Raise the machine to transport height until the cylinders are fully extended.
6. Close transport safety lock valves. (Fig. 13)
7. Attach transport safety chain. (Fig. 18)

Folding

Fig 16.

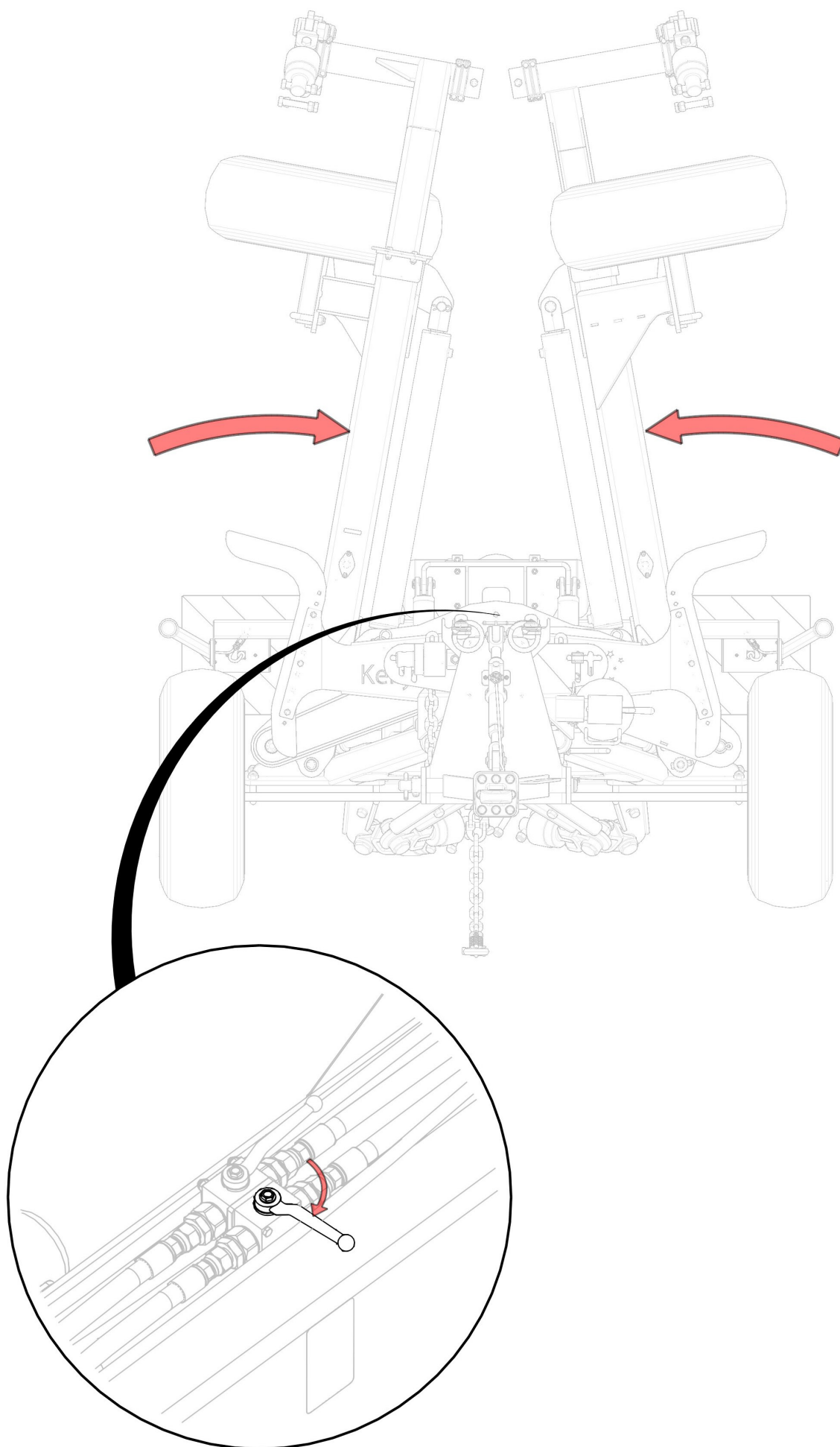

Folding

Fig 17.

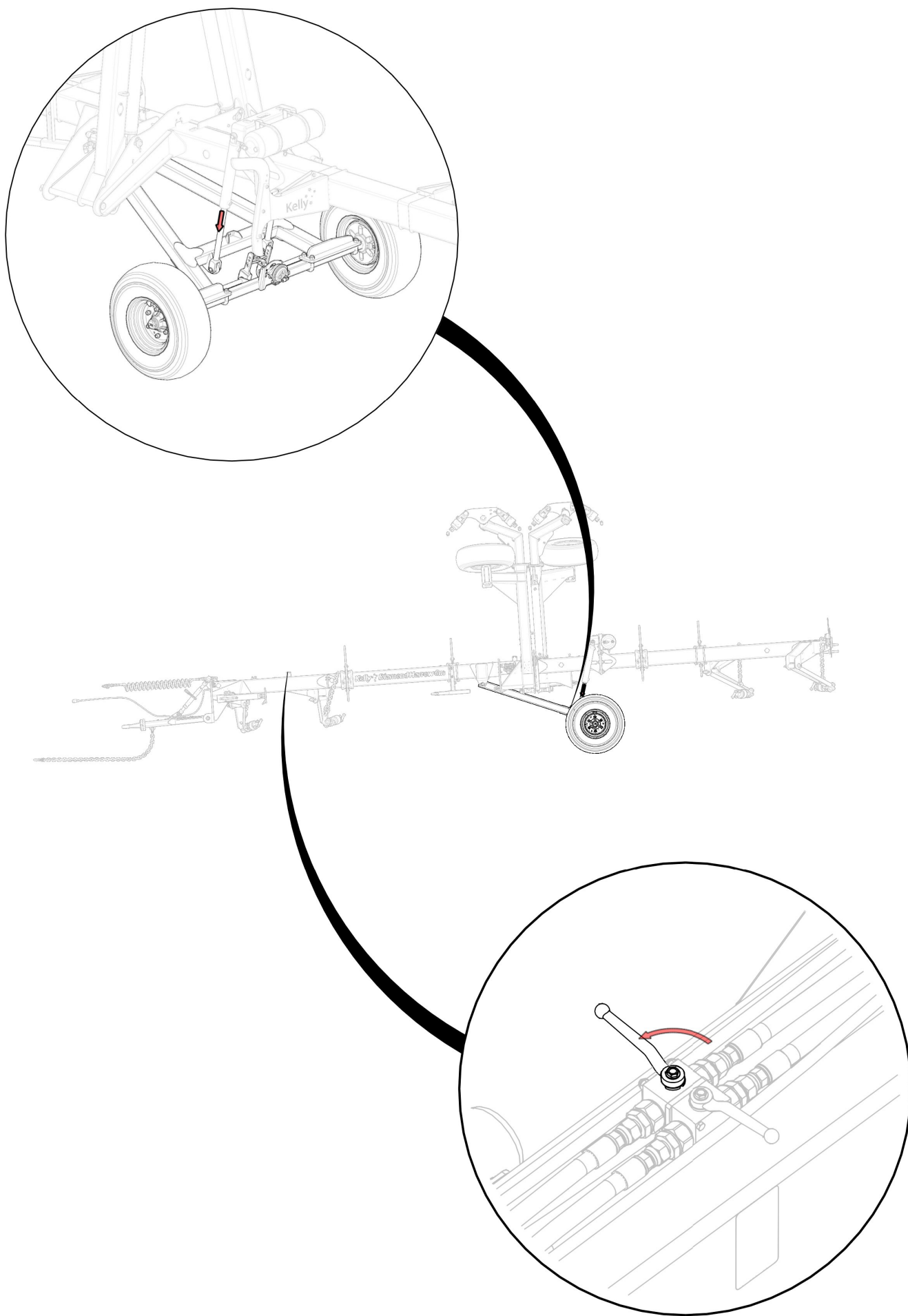

Folding

Fig 18.

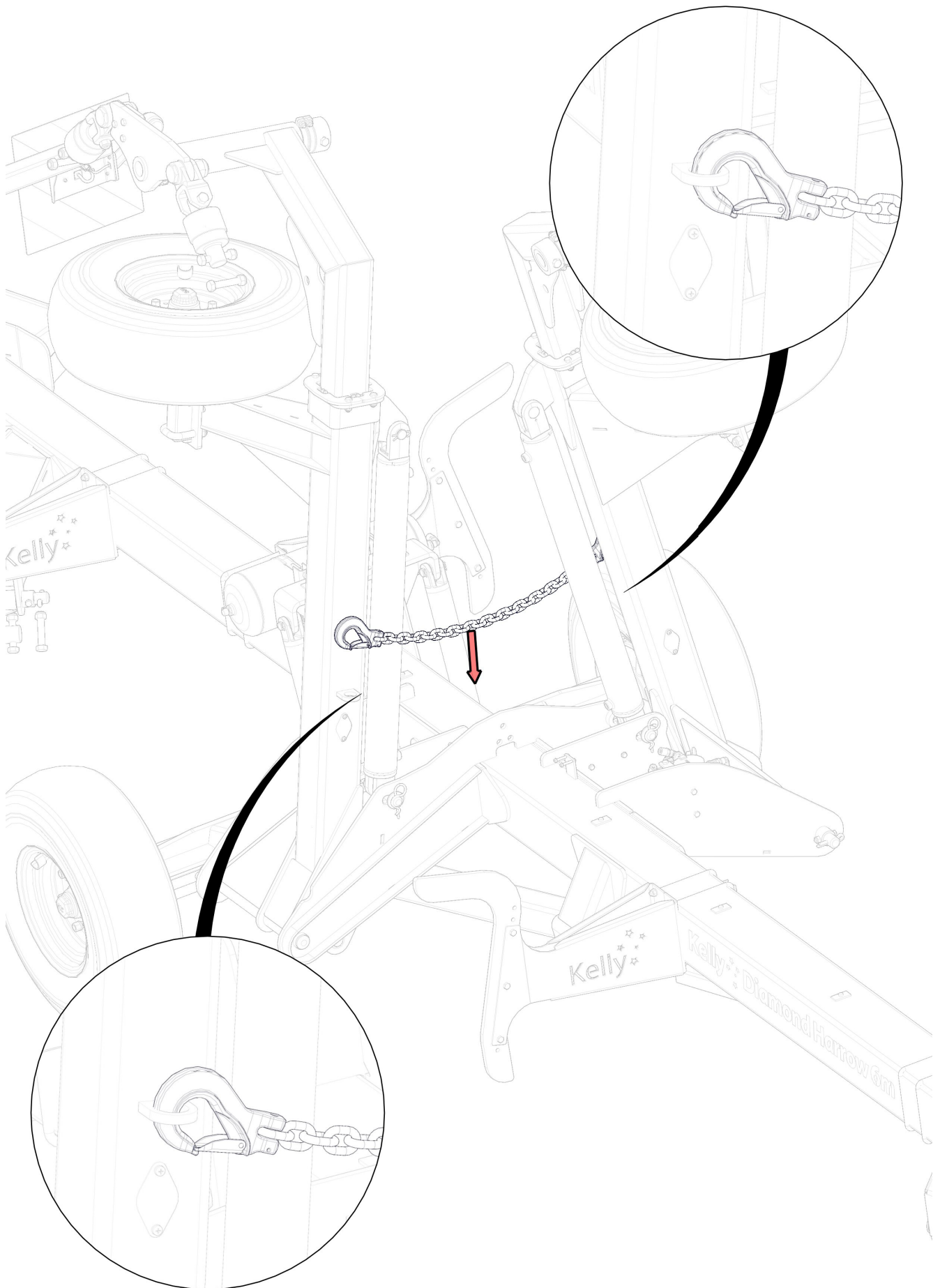

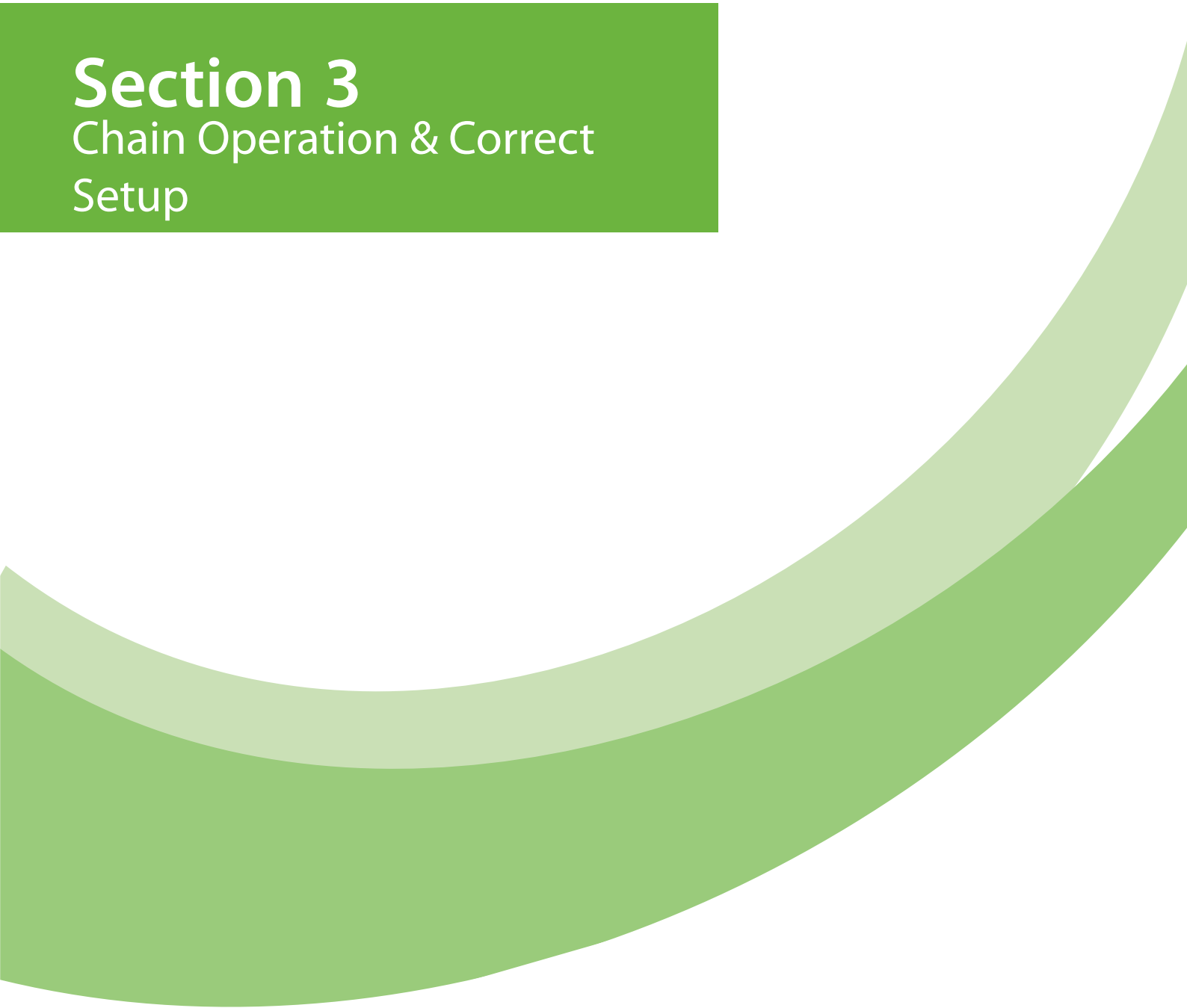

Section 3

Chain Operation & Correct Setup

Importance of good chain setup

Operational

It is imperative that the correct chain tension is maintained. Only through correct tension can a smooth and level finish be achieved in field working.

Loose chains lead to :

- Uneven performance across the width of the machine
- Uneven weed control
- Unsatisfactory incorporation
- Ineffective levelling
- Accelerated or premature chain link wear (not covered by warranty)
- Chains failing to engage with transport locator's when folded
- Machine damage when folding or unfolding
- Uneven field surface with ridges and furrows being created.

A correctly adjusted machine will not cause this phenomenon.

The framework should be horizontal when set on level ground. ie parallel to the ground. Fine adjustments should be made using the adjustor chains at each bearing mount plate.

Frame height adjustment

Machine body must be level front to rear

Ground level

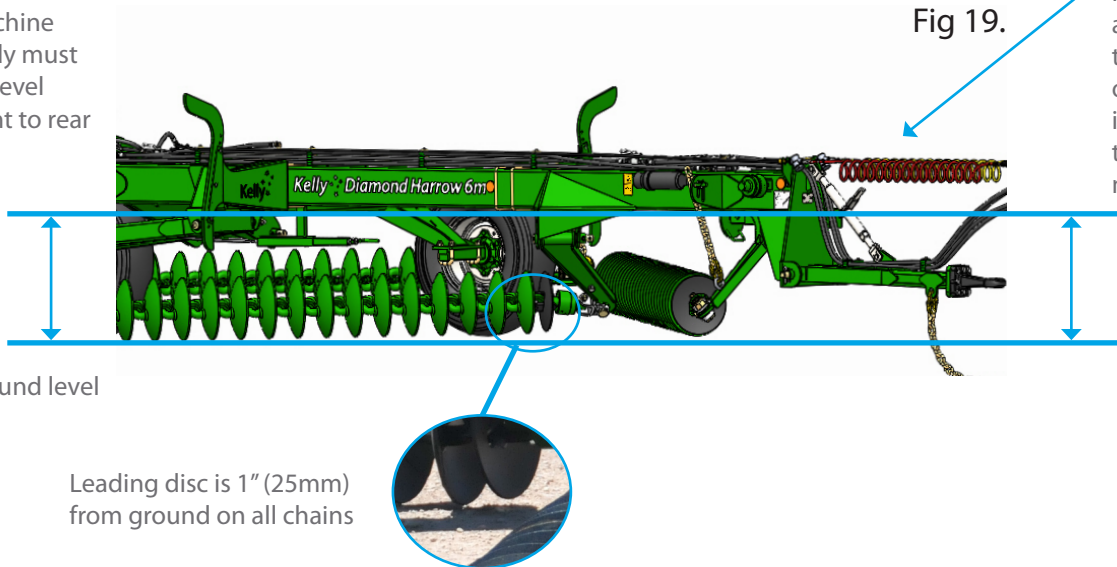

Fig 19.

Set drawbar height by adjusting the ratchet on the frame in order to level machine!

Leading disc is 1" (25mm) from ground on all chains

Once the frame is level tighten the lock nut (Fig 21.) on the drawbar ratchet (Fig 20.). This sets the drawbar height correctly for your tractor.

Fig 20.

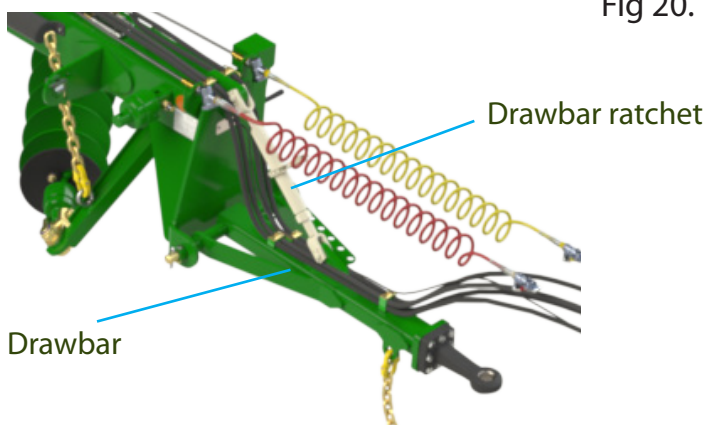
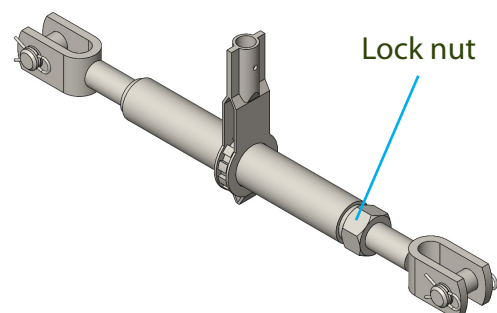

Fig 21.



Wing set up prior to operating

Fig 22.

Make sure the pin is centred

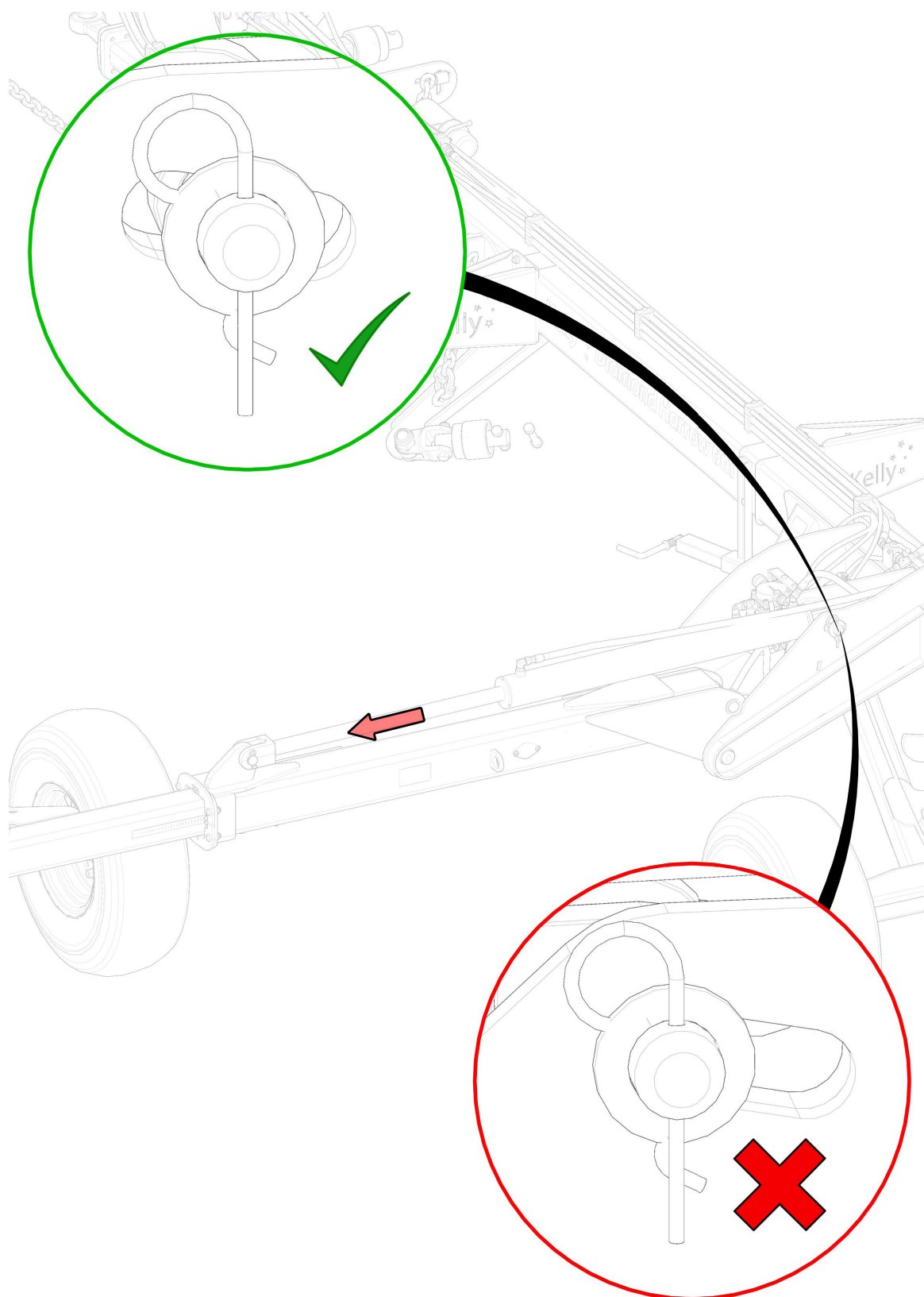

Set chain tension

Wing Tension Travel

It is important that the amount of wing extension be monitored throughout the life of the chain. Optimal outer wing extension should be between 600mm and 800mm. Fully retracted or extended will require chain adjustment.



If the cylinder is fully retracted you may need more discs.

If the cylinder is fully extended it will be necessary to remove a disc from each front and rear chain set.

If the machine has been used for a period of time, the chain is worn down and the cylinder is fully extended you will need to remove disc/s from each front and rear chain set.

Correct chain tension will ensure that the entire length of discs will roll as one. This minimises the movement between each link. If a chain is not adjusted and runs loose, each link acts as a universal joint as the curved chain rolls along and the wear rate between each link is greatly accelerated and can lead to premature failure. The chain links should not wear out before the discs are worn down. **ONLY POOR ADJUSTMENT CAUSES THIS.**

- The chain may sag not more than 150mm from centre line when working
- At rest there should be less than 100mm of sag in the chain.

Fig 24.

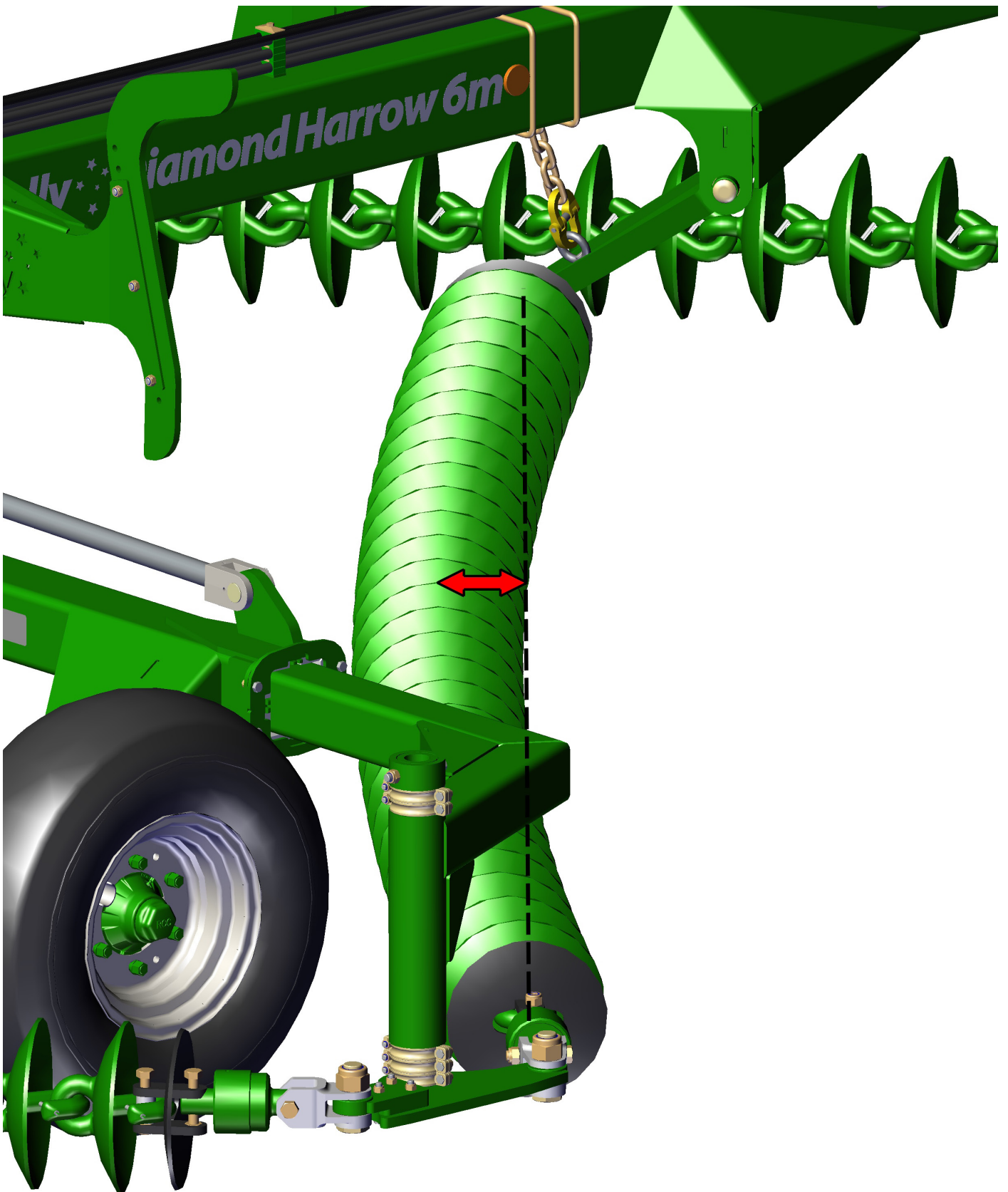

Correct hydraulic chain tensioning

The chain tension is managed by combination of telescopic cylinders, a nitrogen accumulator and a pressure control valve. Pressure is applied to the circuit by unfolding the wing. When the appropriate working pressure is reached (69 bar/1000psi), isolate the circuit by engaging the tension isolation valve.

A chain tension pressure of 69 Bar/ 1000psi is recommended for most situations. Refer to Fig 12. It may however be necessary in different situations to increase the pressure (Max 138 Bar/ 2000psi).

Loosen the lock nut, open the tension isolation valve (Fig 14), activate the unfold circuit while using an allen key to turn the screw in the direction (Fig 25) until the desired pressure is reached on the tension pressure gauge.

To decrease the tension pressure wind the screw all the way out, activate the fold circuit to release the tension pressure. Reactivate the unfold circuit while slowly winding the screw until the desired pressure is reached. (Fig 26.)

When finished close the tension isolating valve (Fig 14) and tighten the lock nut.

Increase tension pressure

Fig 25.

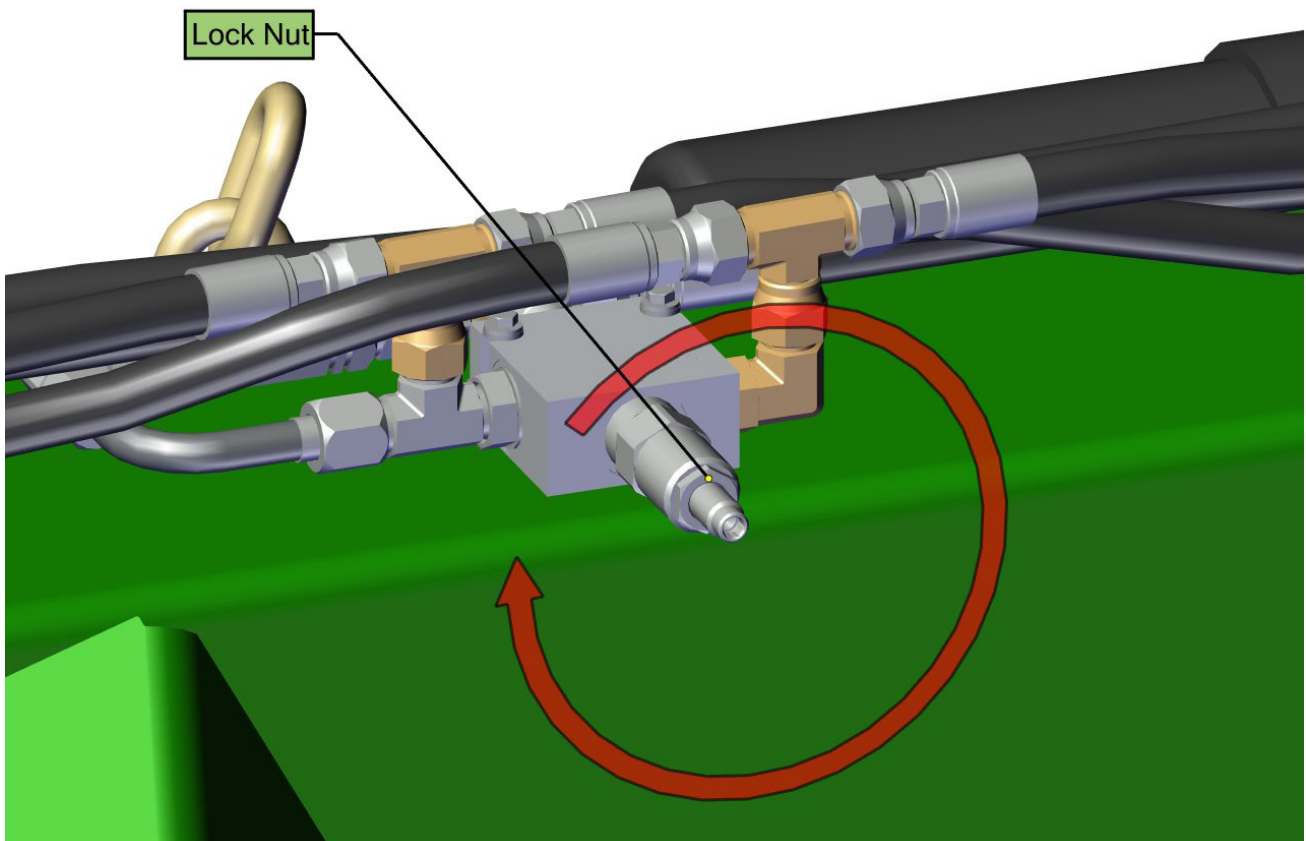

Decrease tension pressure

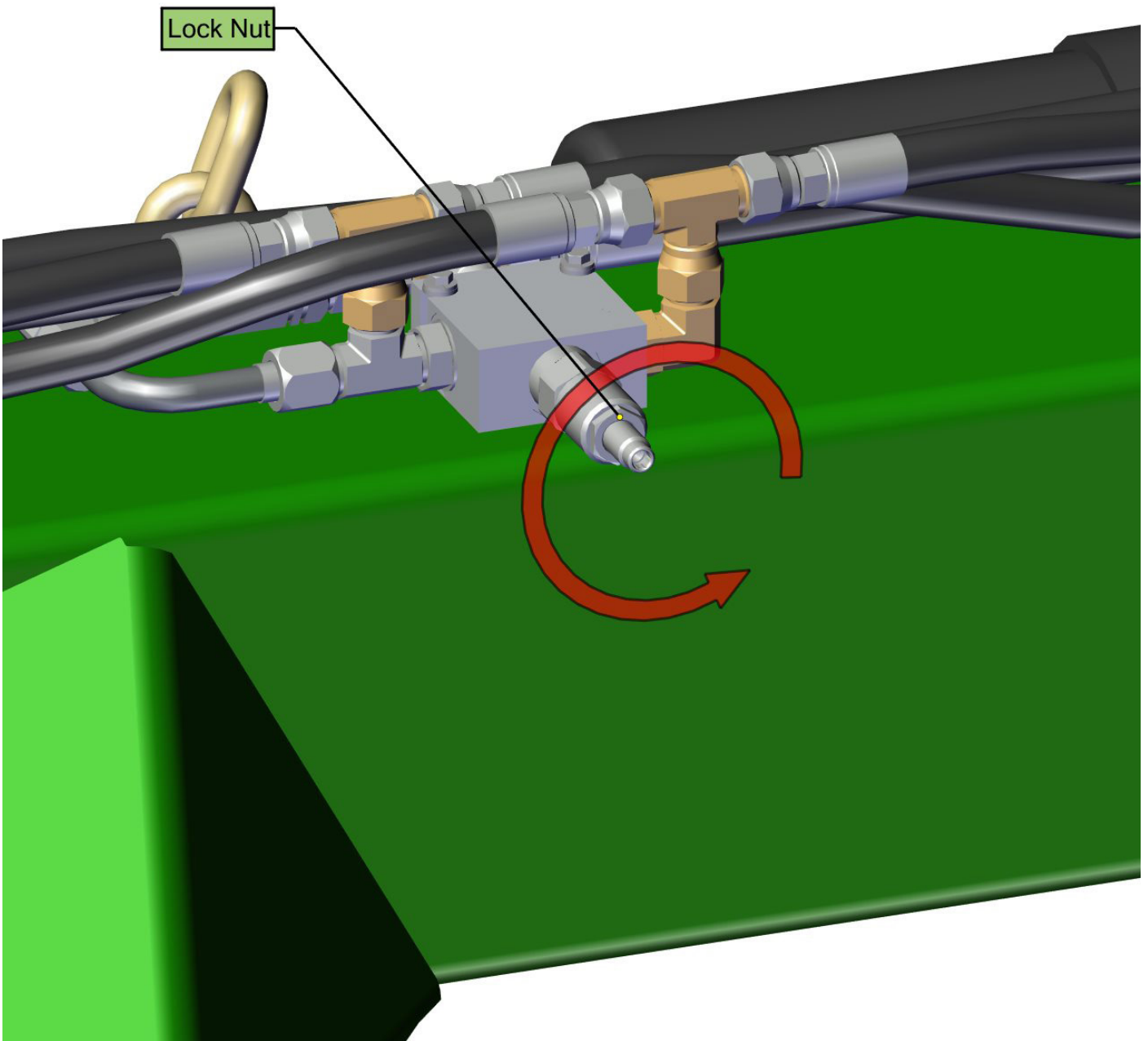

Chain mount arm height adjustment

- Use the tractor hydraulics to raise the frame or chain mount plate that requires adjustment.
- Position a suitable block or stand to support the arm (Fig 27.1)
- Using the tractor hydraulics, lower the machine until the height adjusting chains are loose.
- Remove spring retaining clip (Fig 27.2).
- Slide chain links through slot in lifting arm, turn links 90 degrees for fine adjustment.
- Lift Frame and install retaining clip (Fig 27.3).
- Remove stand.

Fig 27.1.



Fig 27.2.



Fig 27.3.



Dropleg height adjustment

- Release wing tension by opening the tension isolation valve (Fig 14)
- Move spacers to bottom of dropleg to decrease ground clearance (Fig. 28).

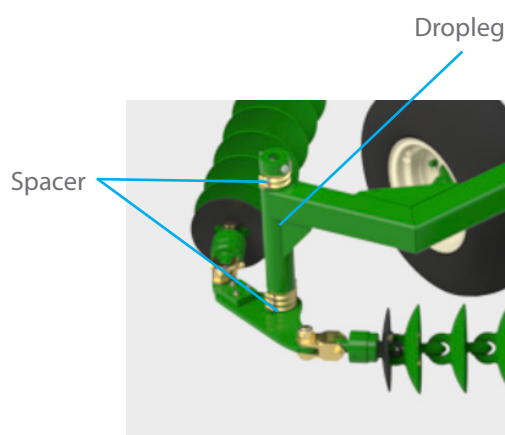
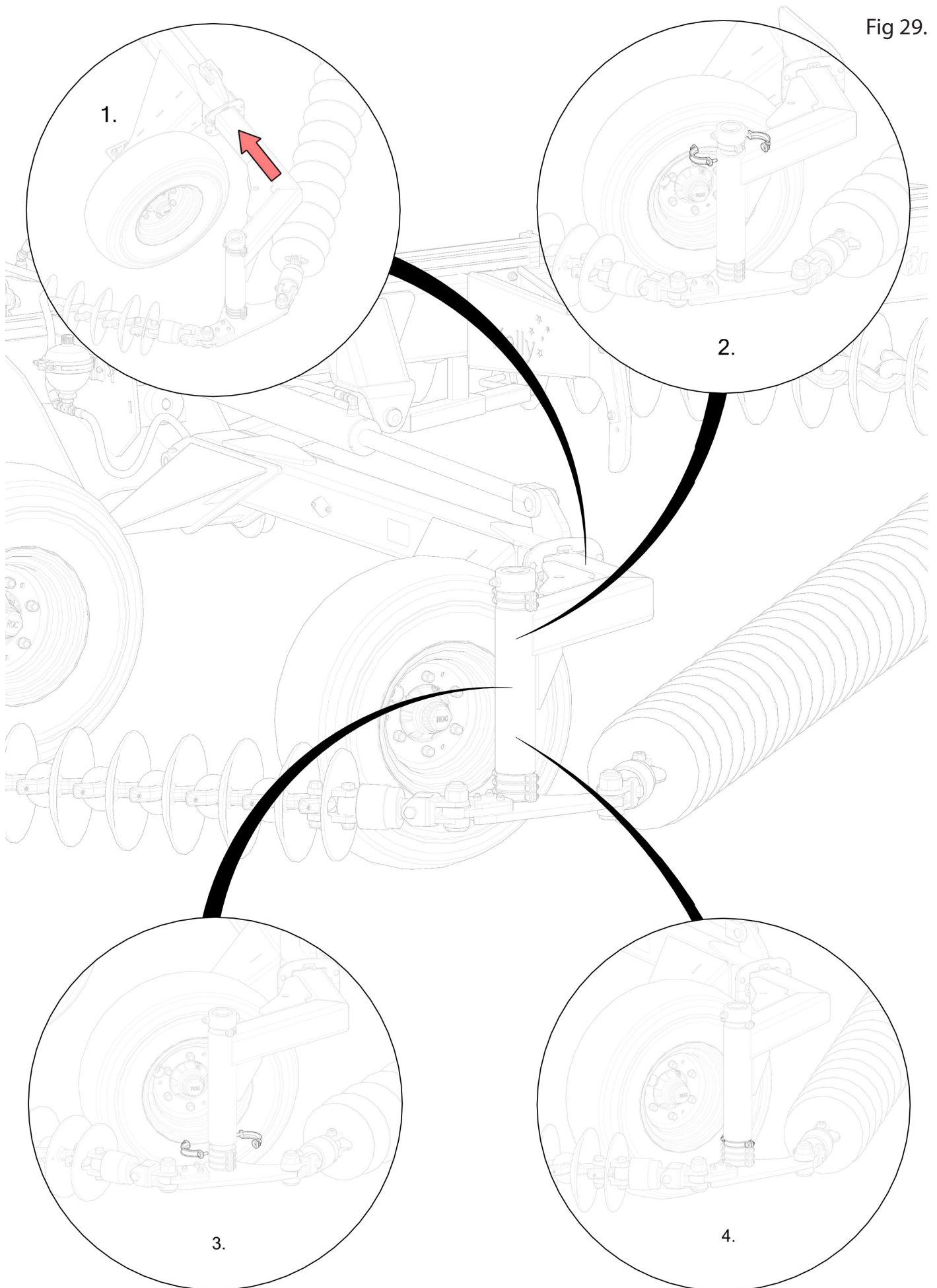

Fig 28.

Dropleg height adjustment

Fig 29.



Fine adjustment for perfect operating results

You may need to continue to adjust certain areas to achieve a level finish and a perfect seedbed.

It is possible with correct adjustment to achieve a level finish in most situations by manipulating the front and rear heights of each chain.

When set too low the leading disc on each chain has the capability of pushing up a ridge of soil that the following chains may not level out. This can occur at the front of each chain, at the front of the rear chains (widest point) and at the front of the machine (either side of center).

When the trailing disc is set too low, it may leave a furrow that may not be filled by other chains. Look for this at the rear of each chain, on the wings at the rear of the front chains and at the very rear of the machine near the center line.

There is enough overlap built into the machine to ensure that it is possible to raise the front of all of the chains just clear of the ground and still achieve a full cut.

Fig 30.

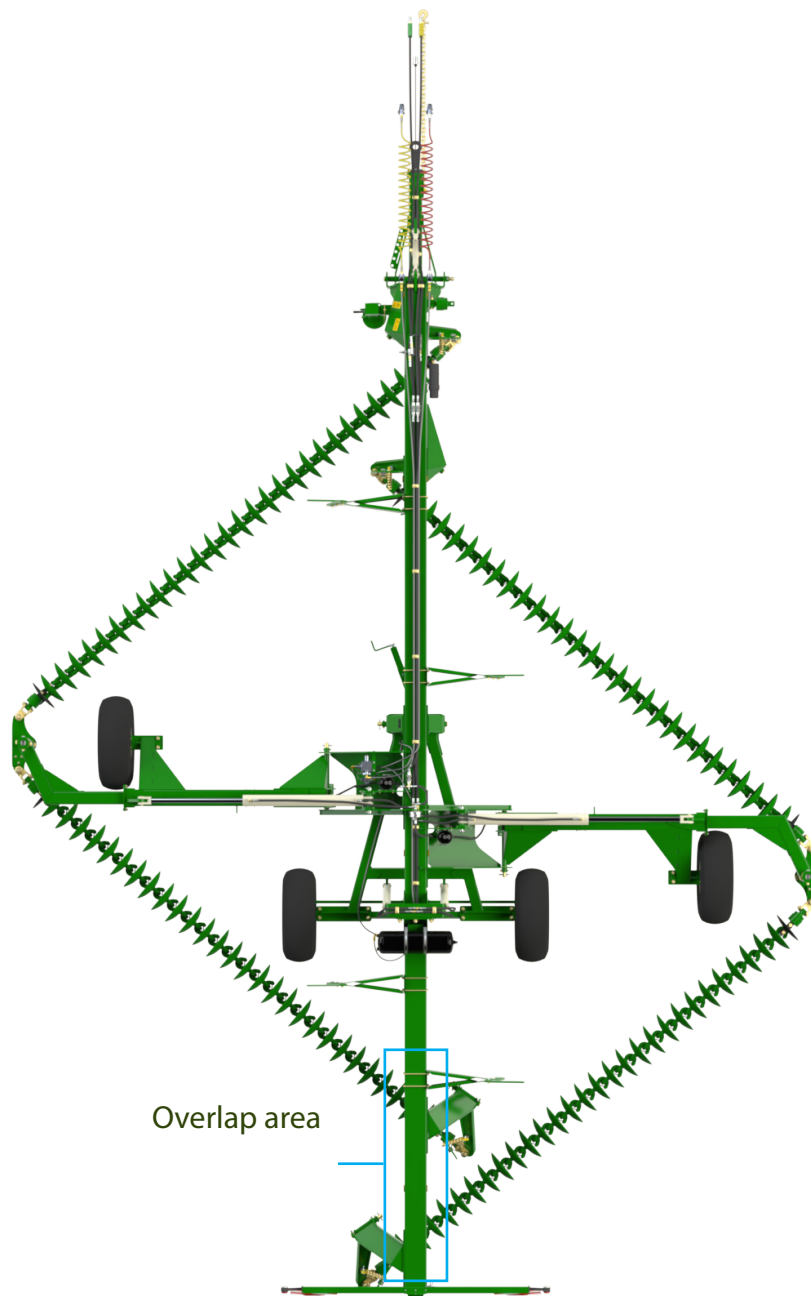

The optimum setting may vary depending on soil cover. In heavy stubble and unworked ground it is possible to set the swivels low to the ground. In light stubble or loose soil it is best to raise the leading discs so that the chains 'feather in' to the soil.

It is important to note that lowering the swivels will not cause the discs to dig deeper or more aggressively. It will result in premature wear of swivel hardware and the first two chain links. It will also cause ridges and furrows.

Digging effectiveness is a result of soil conditions and disc chain construction. The weight, shape, angle and spacing of the discs are the factors which influence efficacy. On hard dry soils it is unrealistic to expect the discs to dig fully or evenly. However, they will still perform well for residue breakdown and seed stimulation.



To prevent injury never lubricate or service the Kelly Tillage System while it is moving (folding up or down or in working motion)

Section 4

Maintenance & Inspection

Maintenance and inspection

Good maintenance is your responsibility

- Before working on your machine, ensure all moving parts have stopped
- Always use a safety support and block the wheels
- Use extreme caution when making adjustments
- Replace shields and guards after servicing and before moving
- After servicing, make sure all tools, parts and service equipment are removed
- Where replacement parts are necessary for periodic maintenance and servicing, genuine factory parts must be used. Kelly Engineering will not guarantee the use of unapproved parts and other damages as a result of their use and will not be liable for injury or warranty if equipment has been altered in any way
- An appropriate fire extinguisher and first aid kit should be kept readily available while performing maintenance.

Intervals

Item to check	First operation	Daily	25 hourly	Pre-season
Hydraulic, hose and cylinders for damage and oil leaks	✓	✓		✓
Airline leaks and hose damage	✓	✓		✓
Loose or missing fasteners/split pins	✓	✓		✓
Check bushes, pivot and cylinder pins for wear and replace as necessary				✓
Swivel unit fasteners	✓	✓		✓
Swivel unit - free and smooth rotation		✓	✓	✓
Swivel unit temperature: Average operating temperature is 55 °C, Failure is indicated at +80 °C	✓	✓		✓
Tyres are inflated to correct pressure	✓	✓	✓	✓
Wheel nuts are tightened at correct torque	✓			✓
Check wheel bearings	✓	✓	✓	✓
Check and tighten dust caps	✓		✓	✓
Tow hitch bolts are tightened at correct torque	✓			✓
Disc roll pins/ locking bolts are in place	✓			✓
Chain is tensioned correctly	✓	✓		✓
Lights are working correctly	✓	✓		✓
Warning signs are attached	✓	✓		✓
Grease wheel bearings				✓
Grease A frame front lift (6M ONLY)			✓	✓

Intervals

Item to check	First operation	Daily	25 hourly	Pre-season
Grease wheel lift bush (6M ONLY)			✓	✓
Grease centre cylinder pins x 2			✓	✓
Grease jockey wheel (9M and 12M ONLY)			✓	✓
Grease wing chain tensioner threads (9M and 12M ONLY)			✓	✓
Grease wing hinge pins x 8			✓	✓
We recommend that swivel units are covered for storage to prevent water penetration.				

Trouble shooting

The majority of the Kelly Tillage System operating problems are due to incorrect adjustment. This trouble shooting section may help you by providing solutions to common problems.

Symptom	Problem	Solution
Wings bouncing	Wing tyre pressure too low	Refer to page 41 for tyre pressure specifications
	Operating speed is too fast for field conditions	Refer to page 41 for operating speed
Chain Links wearing	Chain too loose. Chain loops back when working.	Refer to page 28, if the wing extension is correct then refer to tension pressure adjustment on page 30 and 31
	Swivel set too close to ground.	Refer to page 26 or 32



Never attempt to fold for transport if the chain is clogged with weeds or mud as the extra weight may damage hydraulics or frame

Trouble shooting

Symptom	Problem	Solution
Chain not rotating	Bearing failure in swivel unit	Refer to daily checks on page 37
	Front chain swivels on machine too low Foreign material fouling bearings	Refer to page 26 or 32
Uneven tread wear on transport wheels	Tyre pressure too low Excessive road speed	Inflate to correct pressure refer to table on page 41 Always travel at a safe speed. NEVER EXCEED 25kph.
Chains not locating properly on chain catcher	Chain catcher not correctly precision	Adjust chain catcher precision until chain locates correctly
Operation leaves central ridge behind machine	Front chain swivels are too low	Refer to chain mount arm height adjustment on page 32
Operation leaves central furrow behind machine	Rear chain swivels are too low	Refer to chain mount arm height adjustment on page 32
Ridging on outside edge of machine	Leading end of corresponding rear chain is too low	Refer to drop leg height adjustment on page 32 and 33
Furrow on outside edge	Rear of front chain set too low	Refer to drop leg height adjustment on page 32 and 33
Chain not tensioning properly	Tension cylinder at maximum stroke	Refer to page 28



Never attempt to fold for transport if the chain is clogged with weeds or mud as the extra weight may damage hydraulics or frame

Section 5

Specification

Operating speeds

Operating speeds for normal conditions	
Chain type	Speed
Prickle Chain	10-16 km
Disc Chain	10-12 km
Transport / towing on roads	< 25 km

Tyre pressure

Tyre size	Ply	KPA	Bar
11.5/80/15.3	14	250	2.5

Disc chain lengths and quantities

Model		Length	W36	CL1	R300	SD49	CL2	CL1's per CL2 chain	Prickle Chain
6m	Front right	4.51m	26	28	36	36	19	2	50
	Front left	4.53m	26	28	36	36	19	2	50
	Rear right	4.59m	27	28	37	37	20	2	51
	Rear left	4.61m	27	28	37	37	20	2	51

For correct chain tension, chain links may need to be removed from the end of the chain as follows:

CL2 Disc Chain - unhook disc chain link/s from end of the disc chain

CL1 Disc Chain - unhook disc chain link/s from end of the disc chain

K4 Disc Chain - unhook disc chain link/s from end of the disc chain

Spiked Disc Chain - cut a disc chain link from the end of the disc chain

R300 Disc Chain - cut a disc chain link from the end of the disc chain

W36 Disc Chain - cut a disc chain link from the end of the disc chain

Prickle Chain - cut a prickle chain link from the end of the prickle chain



Bolt torque settings

Bolt Type	Wheel nut	U Bolt		Class 8.8 Bolt				Class 10.9 Bolt	
Bolt Size	M18	M12	M20	M10	M12	M16	M24	M16	M20
Spanner	27	18	30	16	18	24	36	24	30
Ft lb	255	36	191	32	48	140	270	214	300
Nm	345	50	260	44	65	190	370	290	406

[1] When fitting a wheel & tyre to a hub, tighten the wheel nuts in a star pattern to the correct tension. To achieve this choose a wheel nut & tighten, then proceed to the opposite side of the hub to the next wheel nut & tighten & so on until all wheel nuts are tight. Then repeat the procedure to check that all nuts are tight. Do not use impact tools to tighten wheel nuts. For a guide to the correct tension of the wheel nuts please use the appropriate tension for your size wheel nuts from the Bolt Torque Settings table.

Torque values are for dry threads and surfaces however, it is permissible to apply a small amount of anti corrosive oil to the threads.

Fig 32.

