



12X

KELLY 12X
ASSEMBLY MANUAL

REVISION G – JUNE 2022

Kelly Engineering
PO Box 100
Booleroo Centre
South Australia 5482



+61 8 8667 2253



kellytillage.com



sales@kellytillage.com



Thank you for choosing a Kelly Tillage product

We trust that you find the following manual clear and easy to follow. If you should require additional customer support or assistance, please do not hesitate to contact us.

Spare parts can be purchased, as required, through your local dealer or by contacting the Kelly team directly.

Kelly welcomes feedback. Should you have any difficulties that you wish to raise, suggestions for improvement or modifications that you feel would enhance our products we look forward to hearing from you.

Contact Information

Australia

Kelly Engineering

PO Box 100

Booleroo Centre SA 5482

Phone: + 61 8 8667 2253

Email: sales@kellytillage.com

Spare Parts: parts@kellytillage.com

Website: www.kellytillage.com

United States – Spare Parts

Hood & Company Inc

Springfield MO

Phone: +1 417 865 2100

Email: parts@hoodco.com

Canada – Spare Parts

Adair Sales & Marketing Company Inc

Swift Current SK

Phone: +1 306 773 0996

Email: parts@adairreps.com

Contents

SECTION 1 Unpacking	6
SECTION 2 Parts and Assembly	8
SECTION 3 Hydraulics	41
SECTION 4 Decal Application	58
SECTION 5 Light Kit	68
SECTION 6 Chain Assembly	75
SECTION 7 Diagrams and Charts	84
SECTION 8 Chain Field Settings	87



This symbol indicates which bag the relevant fasteners are in



This symbol indicates which bag the relevant hydraulics are in



This symbol indicates which way the machine is travelling

Bolt Torque Settings

Bolt Type	Wheel nut		U Bolt			Class 8.8 Bolt							Class 10.9 Bolt	Grade 8 Bolt
	M12	M18	M12	M16	M20	M6	M8	M10	M12	M16	M20	M24	M20	1" UNF
Spanner	19	27	19	24	30	10	13	17	19	24	30	36	30	9/16"
Ft lb	65	221	21	53	104	7	16	32	57	140	273	472	389	849
Nm	88	300	29	72	141	9	22	44	77	190	370	640	528	1151

[1] When fitting a wheel & tire to a hub, tighten the wheel nuts in a star pattern to the correct tension. To achieve this, choose a wheel nut & tighten, then proceed to the opposite side of the hub to the next wheel nut & tighten & so on until all wheel nuts are tight. Then repeat the procedure to check that all nuts are tight. Do not use impact tools to tighten wheel nuts. For a guide to the correct tension of the wheel nuts please use the appropriate tension for your size wheel nuts from the Bolt Torque Settings table.

Torque values are for dry threads and surfaces however it is permissible to apply a small amount of anti-corrosive oil to the threads.

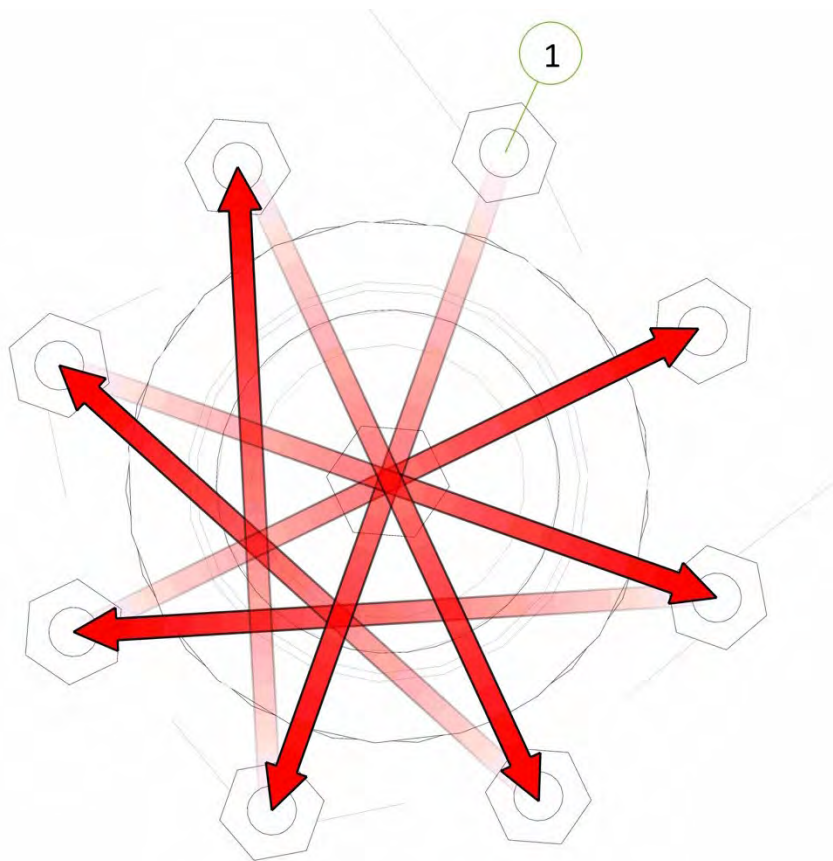



SECTION 1
UNPACKING

SECTION 1 UNPACKING



CAUTION

Before cutting straps attach slings or chains and take the weight of the frames to avoid them slipping or falling and causing injury.



CAUTION

Wear eye and hand protection when cutting straps. Sharp edges are exposed as straps separate and may cause injury.



CAUTION

To avoid falling or moving components, before cutting straps attach slings or chains to individual pieces and only cut the straps holding the piece to be lifted.

- Cut straps holding bundles and separate parts and place in assembly area
- Identify parts for each machine by serial no. or description and separate. Open parts box and check that all parts are accounted for against checklist
- Once all parts have been identified machines are ready for assembly
- Read assembly instructions before proceeding



SECTION 2
PARTS & ASSEMBLY



Fastener Kits Bags Location

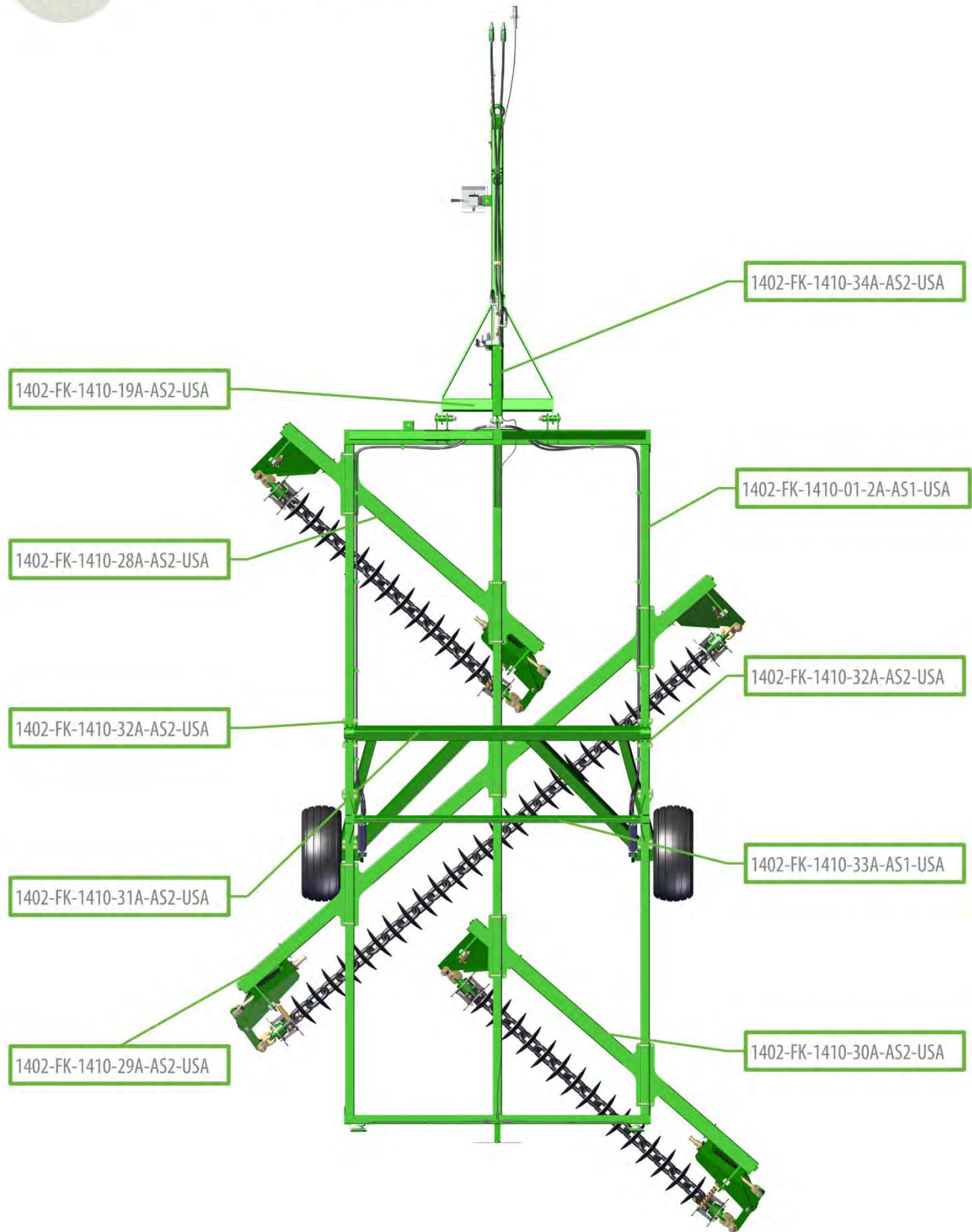

Item No.	Description	Number	Qty
1	Centre Frame	1410-01-2	1



Support frame with blocks or stands during initial assembly

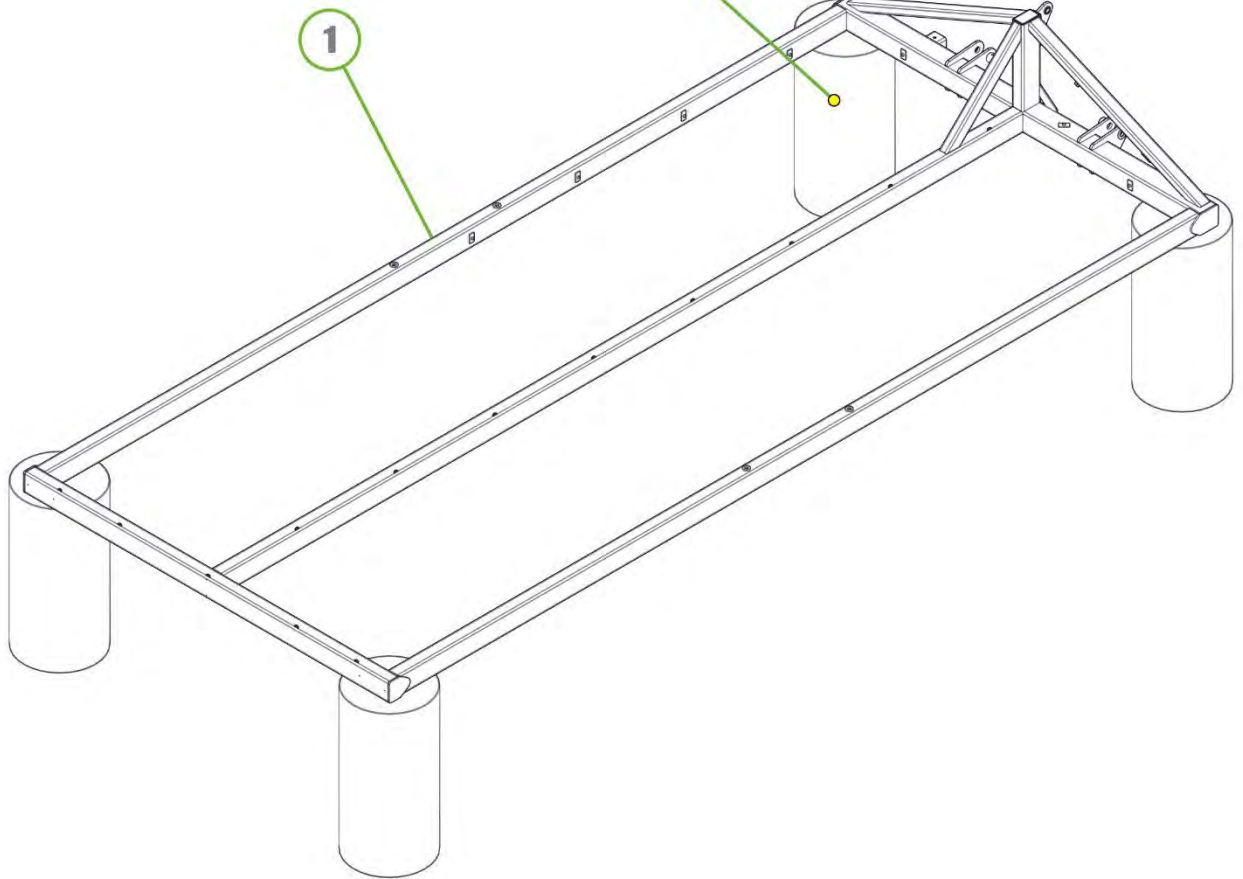

Item No.	Description	Number	Qty
1	Wheel Arm Frame	1410-31	1
2	Wheel Arm Bearing	1410-32	2
3	Grease Nipple 1/4" UNF	0181-GN1-4	2

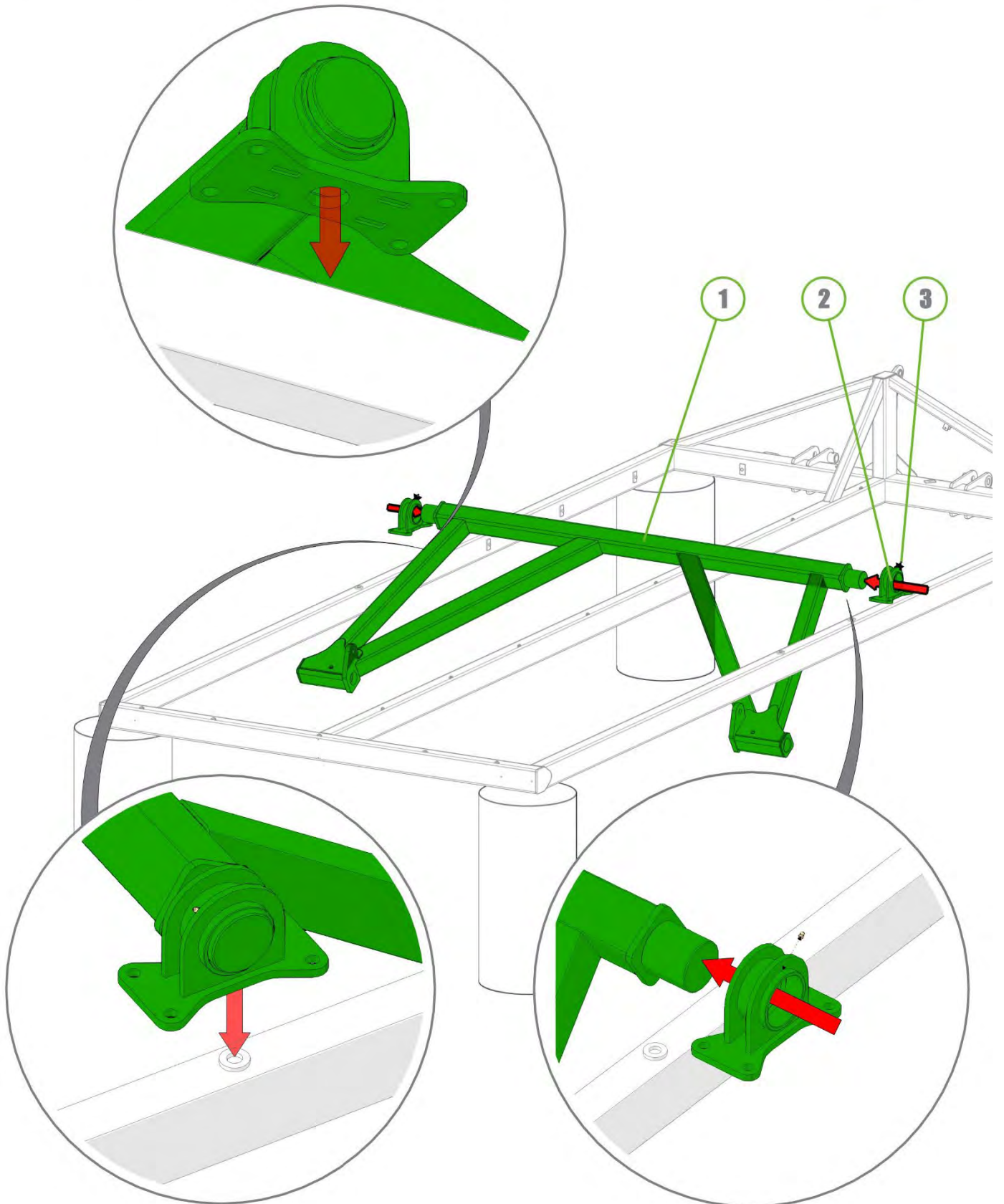

Item No.	Description	Number	Qty
1	Nyloc Nut M16	0221-NYL16	8
2	U-Bolt M16 x 167 Deep x 79 Wide	0271-1616779U	4
3	Washer Flat M16	0231-F16	8



1410-32A-AS2

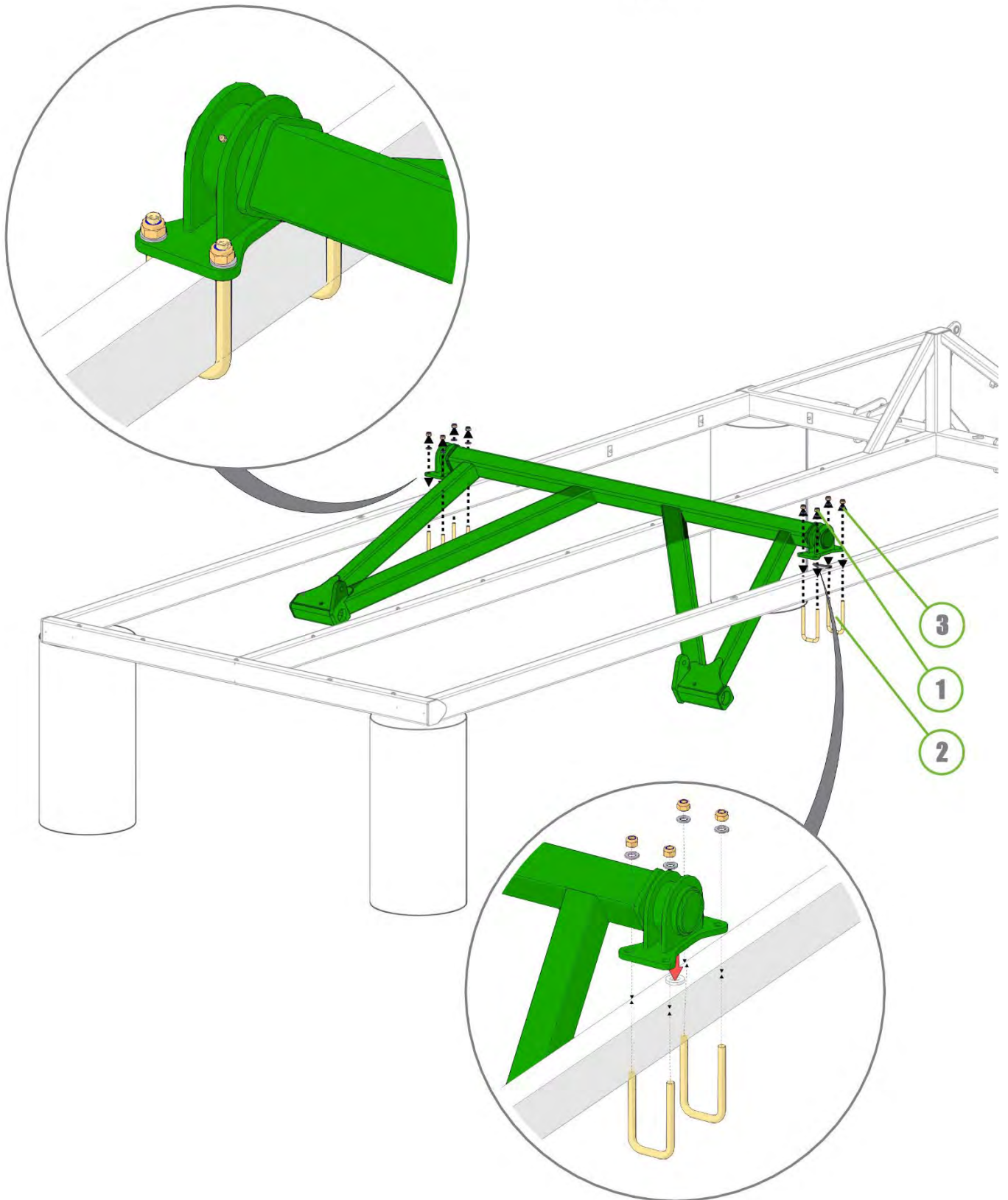

Item No.	Description	Number	Qty
1	31/13.5-15 Tire and Rim Assembly	0751-31-13.5-15	2
2	2.75"R C/W 6 tonne 8 on 8" PCD Complete Assembly inc GS	0733-LG6080067	2
3	M20 x 140 Class 8.8 ZP Bolt	0211-20140	2
4	Nyloc Nut M20	0221-NYL20	2
5	Washer Flat M20	0231-F20	4



1410-31A-AS2

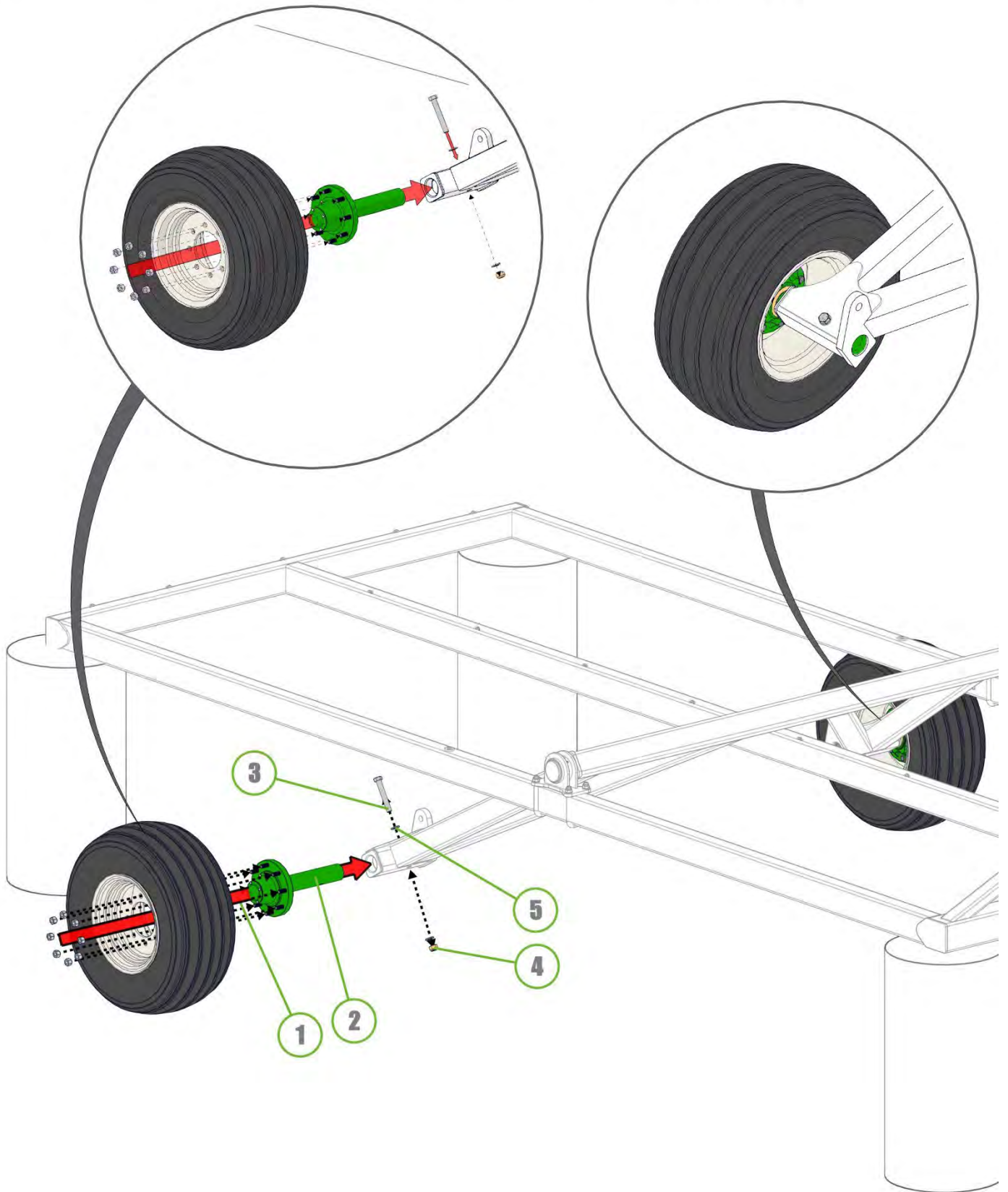

Item No.	Description	Number	Qty
1	Nyloc Nut M16	0221-NYL16	16
2	Ram Mount Frame	1410-33	1
3	U-Bolt M16 x 167 Deep x 79 Wide	0271-1616077	8
4	Washer Flat M16	0231-F16	16



1410-33A-AS1

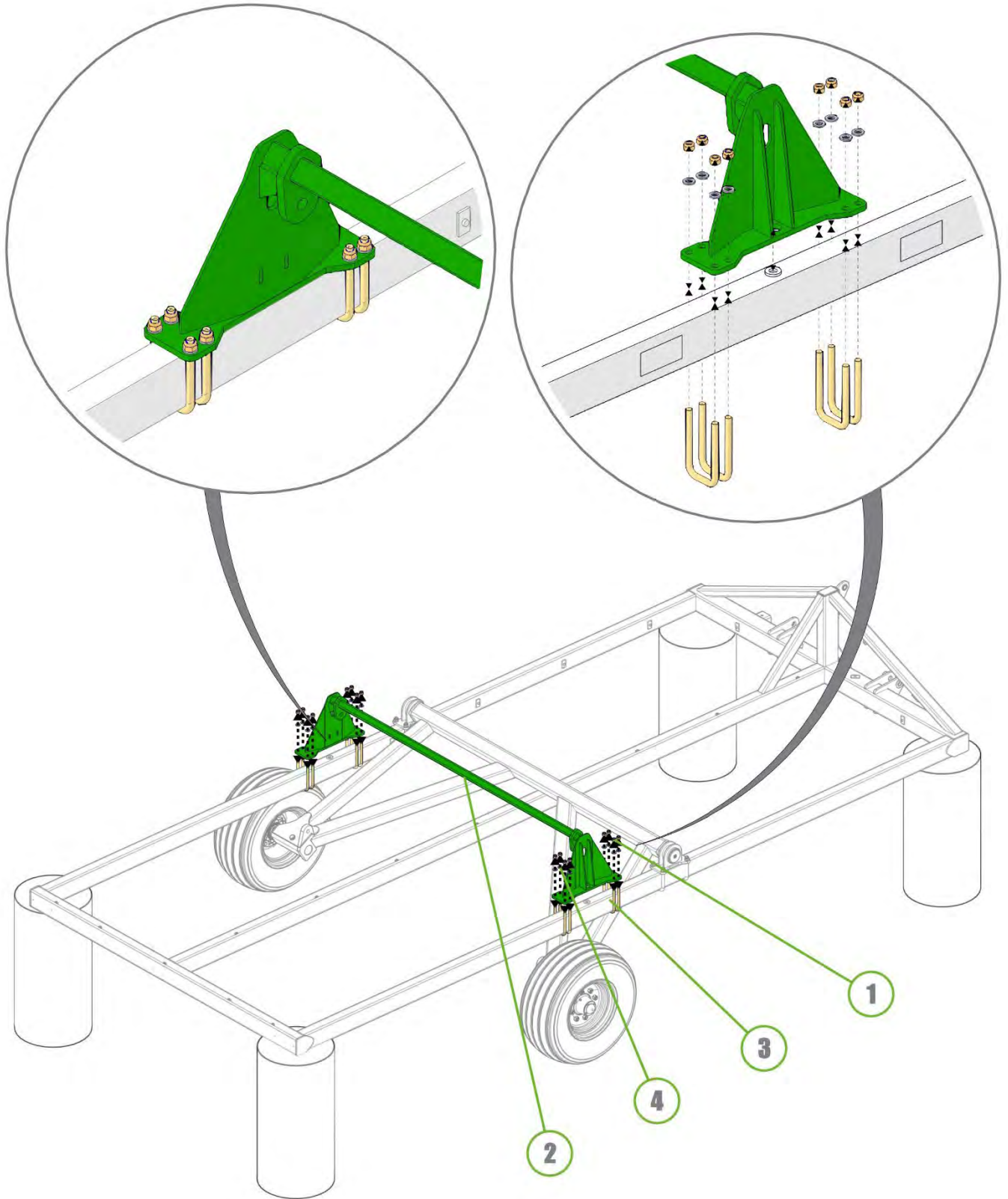

Item No.	Description	Number	Qty
1	2.5" Bore x 16" Stroke Hydraulic Cylinder	0311-2516	2

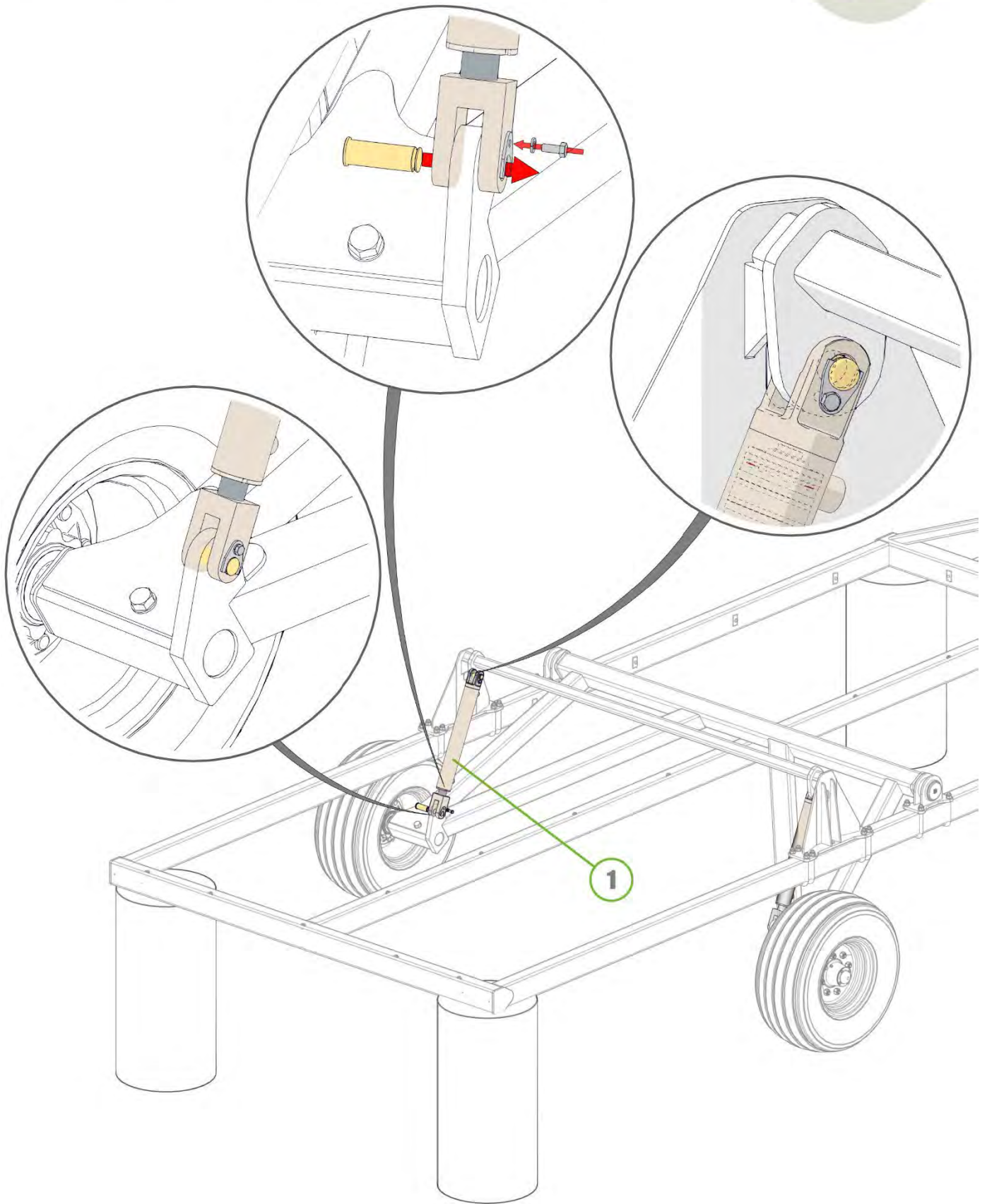

Item No.	Description	Number	Qty
1	Cotter Pin M13 x 63	0261-PINC1363	2
2	M12 x 65 Grade 8.8 ZP Bolt	0211-1265	2
3	Nyloc Nut M12	0221-NYL12	2
4	Grease Nipple 1/4" UNF	0181-GN1-4	4
5	Drawbar	1410-19	1
6	Tail Frame Pivot pin	0801-10-08-175	2



1410-01-2A-AS1

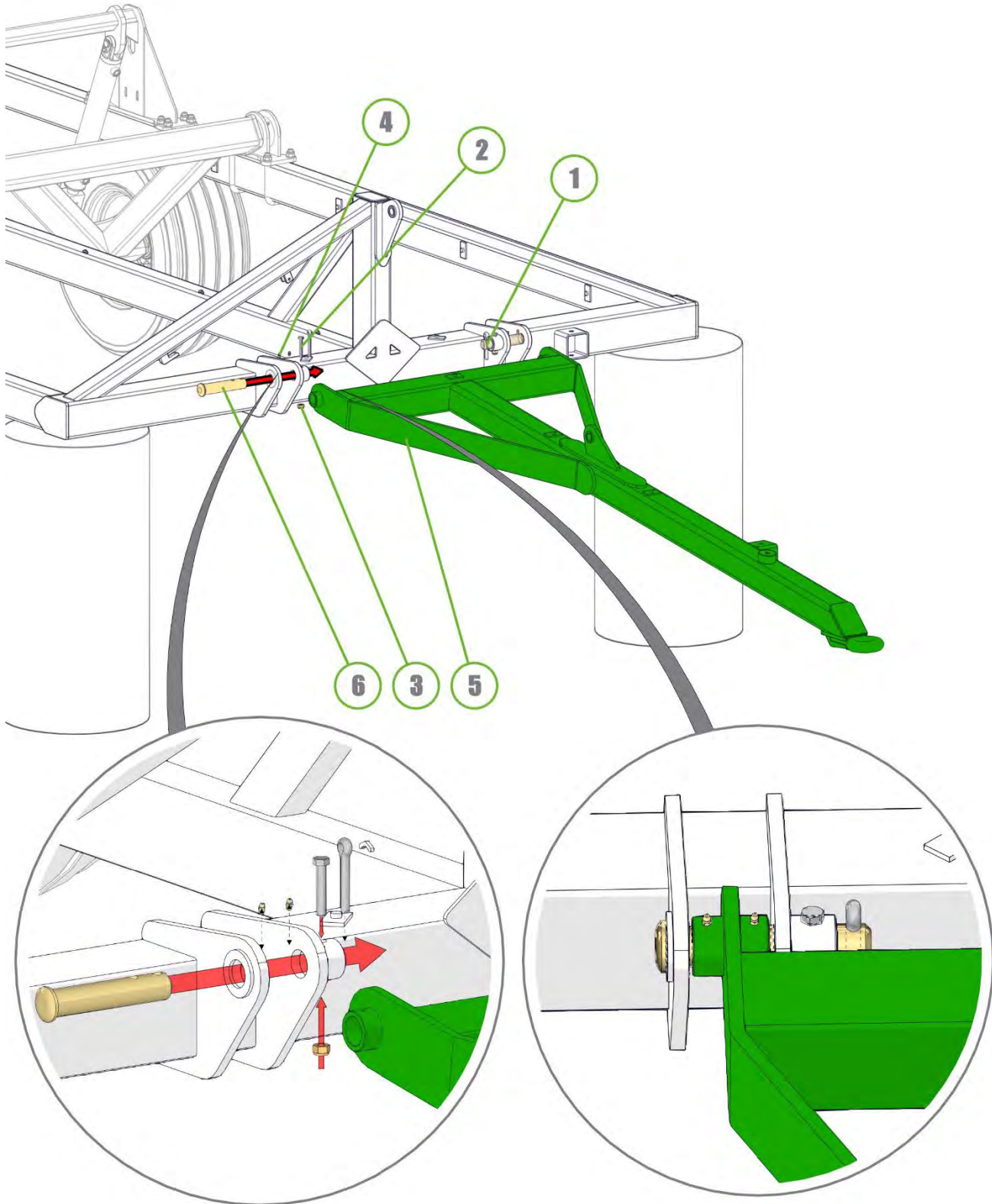

Item No.	Description	Number	Qty
1	2.5" Bore x 6" Stroke Extended Cylinder	0311-2506EXT	1
2	Depth Stop Sleeve	1410-34	1
3	R Clip 3mm	0511-RCLIP3	1
4	Washer Flat 1"	0232-F1	2



1410-34A-AS2

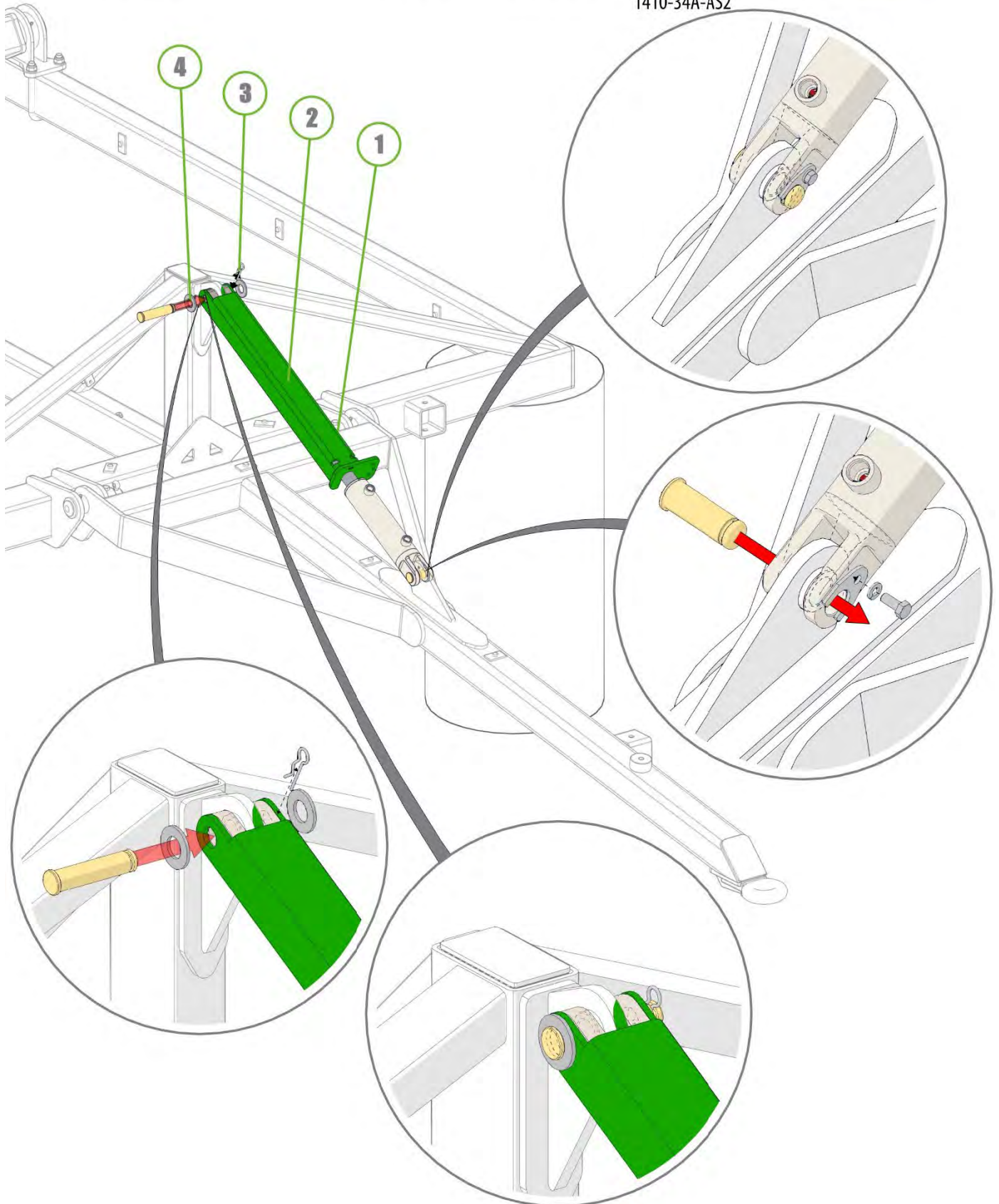

Item No.	Description	Number	Qty
1	3/8"-16 x 1-1/4" Pipe Size Zinc Plated Round Bend U-Bolt	0274-42026	1
2	Compression Cup Washer	0231-SPRINGCUP	7
3	Nyloc Nut 3/8" UNC	0222-NYL3-8	2
4	Round Linch Pin Ø4.5mm x 35mm S3545	0266-Linch Pin 4x35	1
5	Shoulder Screw M12 x 16 x 110	0211-12110SHSCREW	2
6	Washer Flat M10	0231-F10	2



1410-34A-AS2

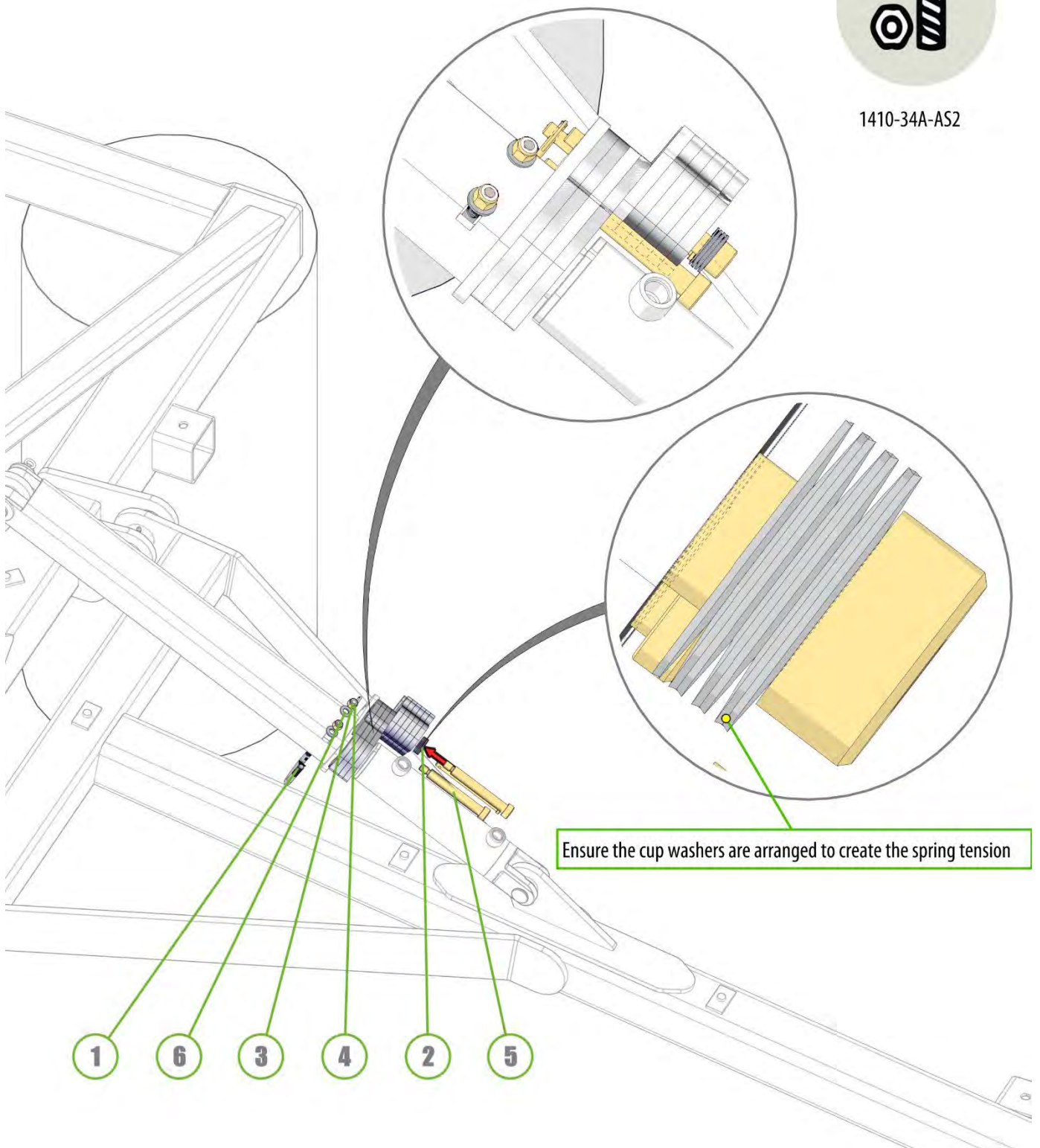

Item No.	Description	Number	Qty
1	M16 x 35 Grade 8.8 ZP Bolt	0211-1635	1
2	Washer Flat M16	0231-F16	1
3	Washer Spring M16	0231-S16	1
4	Hose Post Spring	1601-CDB-00-0012	1
5	Safety Chain Assembly	1402-16	1



1410-19A-AS2

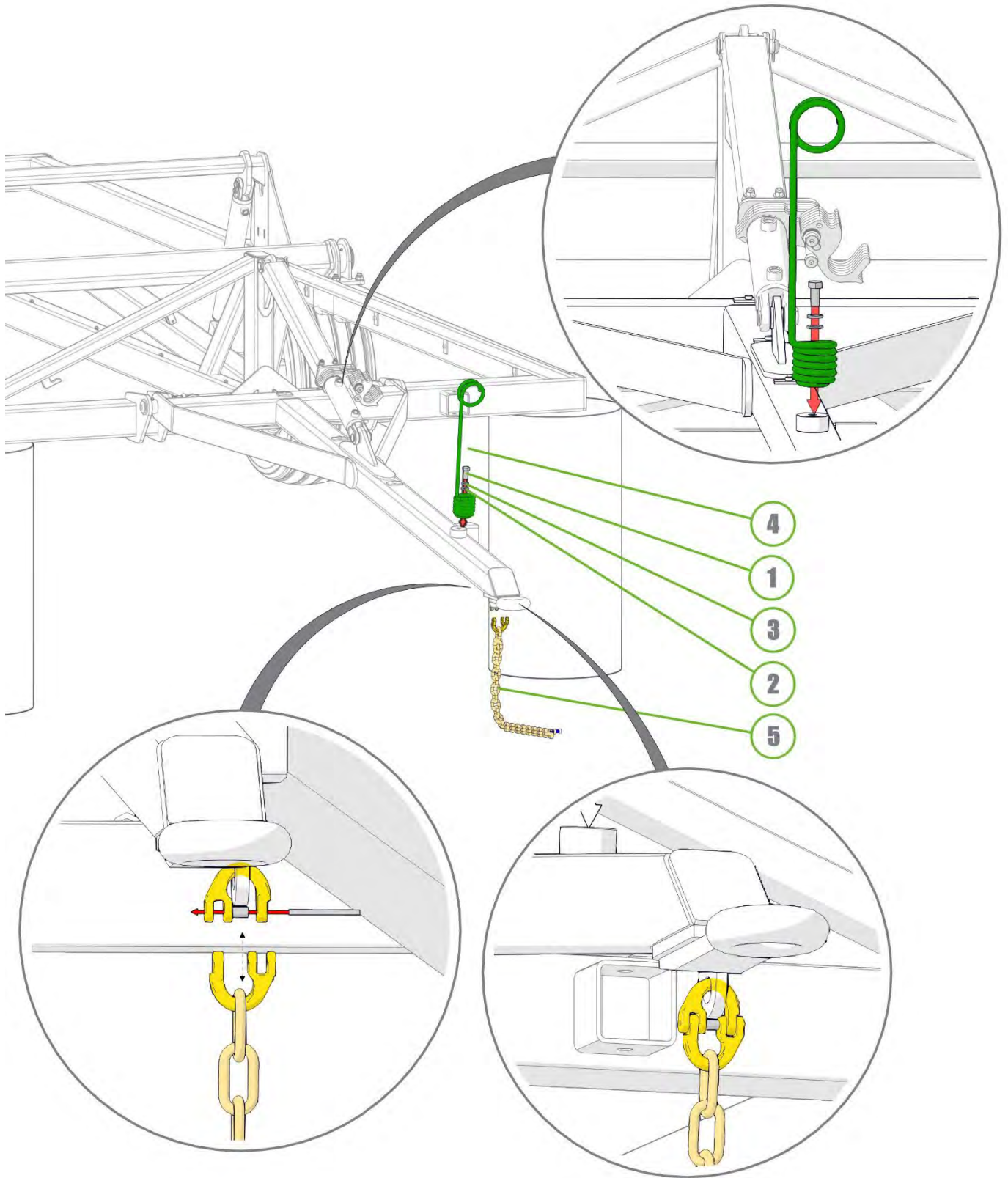

Item No.	Description	Number	Qty
1	Jack Pin	0801-B3077	1
2	US 3t Jack Assembly	0810-31-US	1



1410-19A-AS2

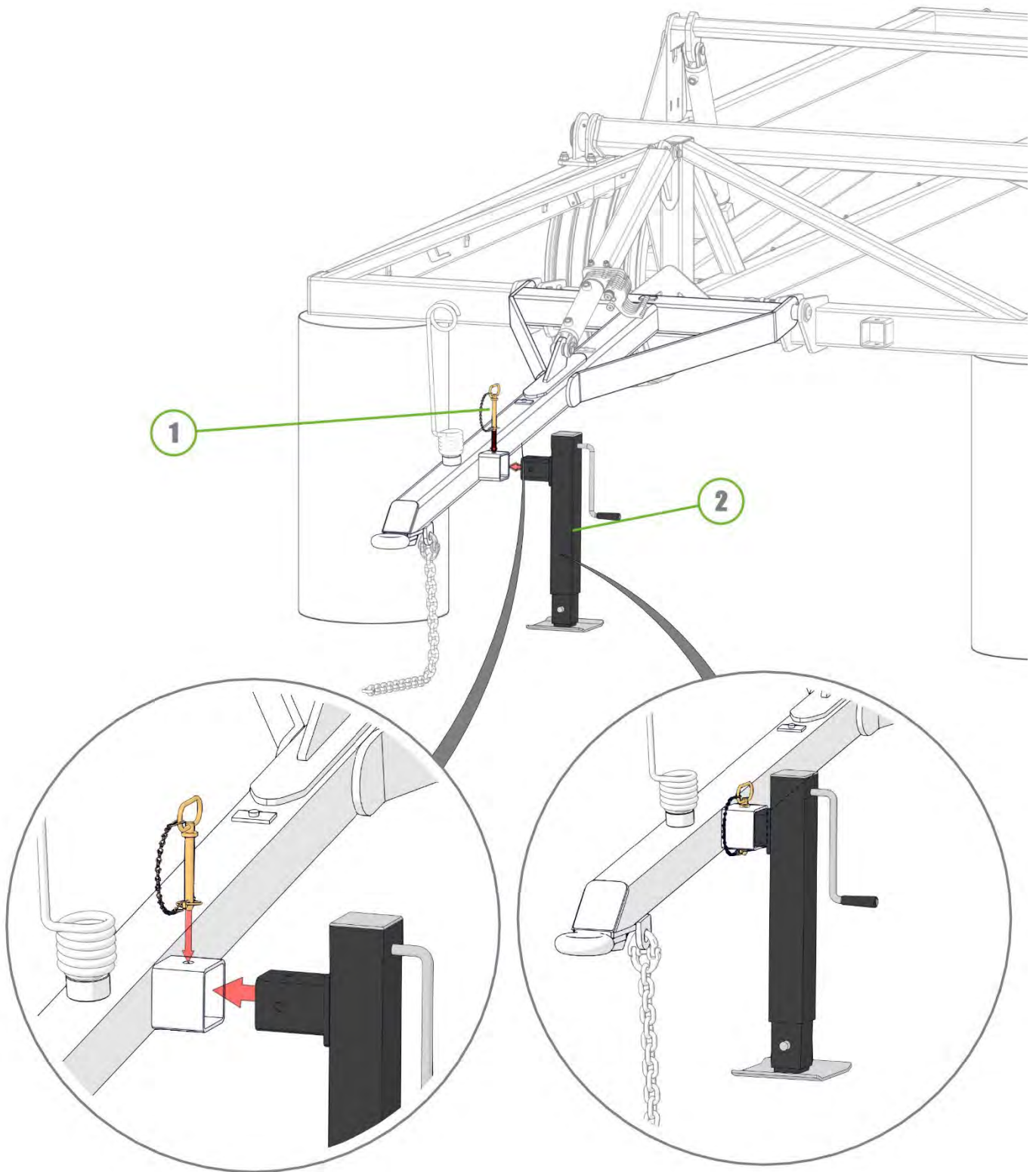



Remove stands, sit on wheels and support jack.

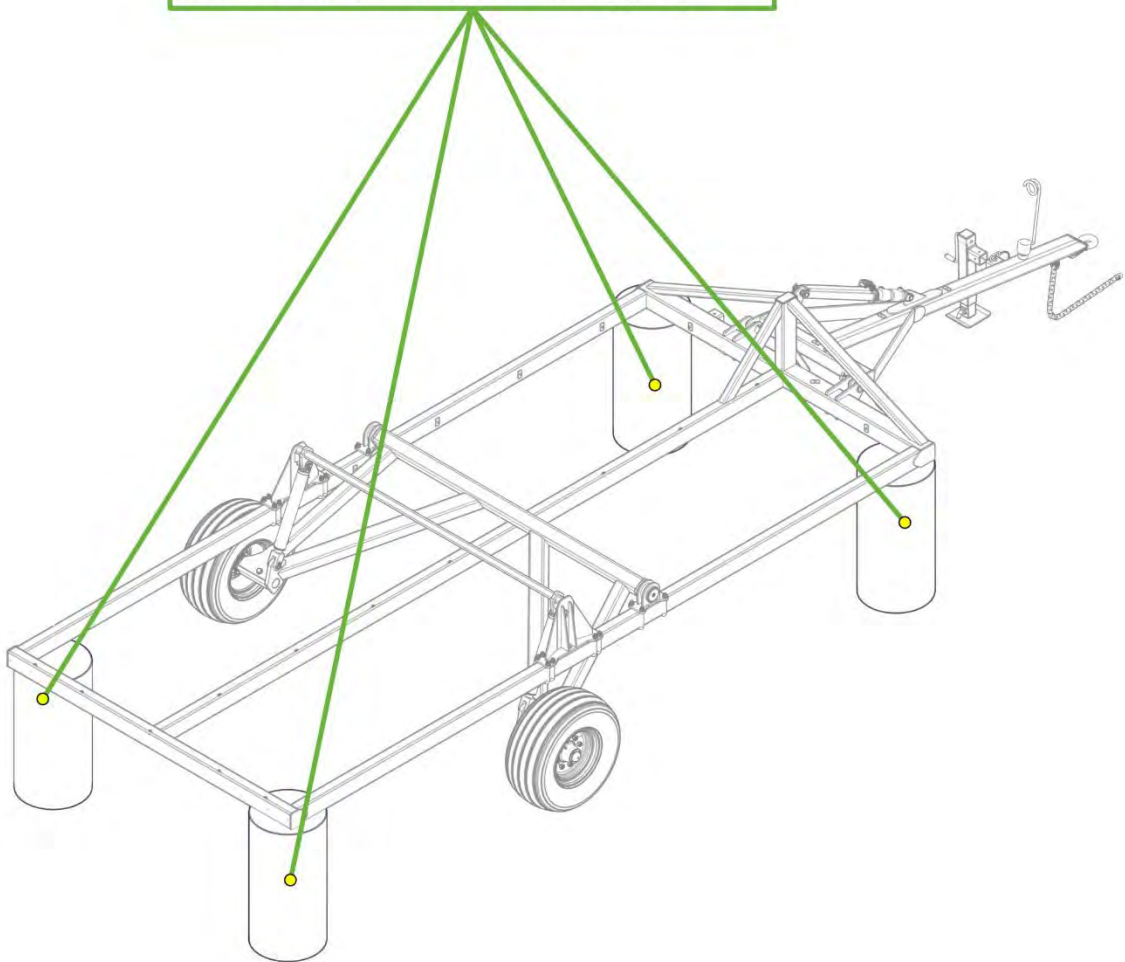

Item No.	Description	Number	Qty
1	Front Module	1410-28-2	1
2	U-Bolt M16 x 167 Deep X 79 Wide	0271-1616779U	4
3	Nyloc Nut M16	0221-NYL16	8
4	Washer Flat M16	0231-F16	8



1410-28A-AS2

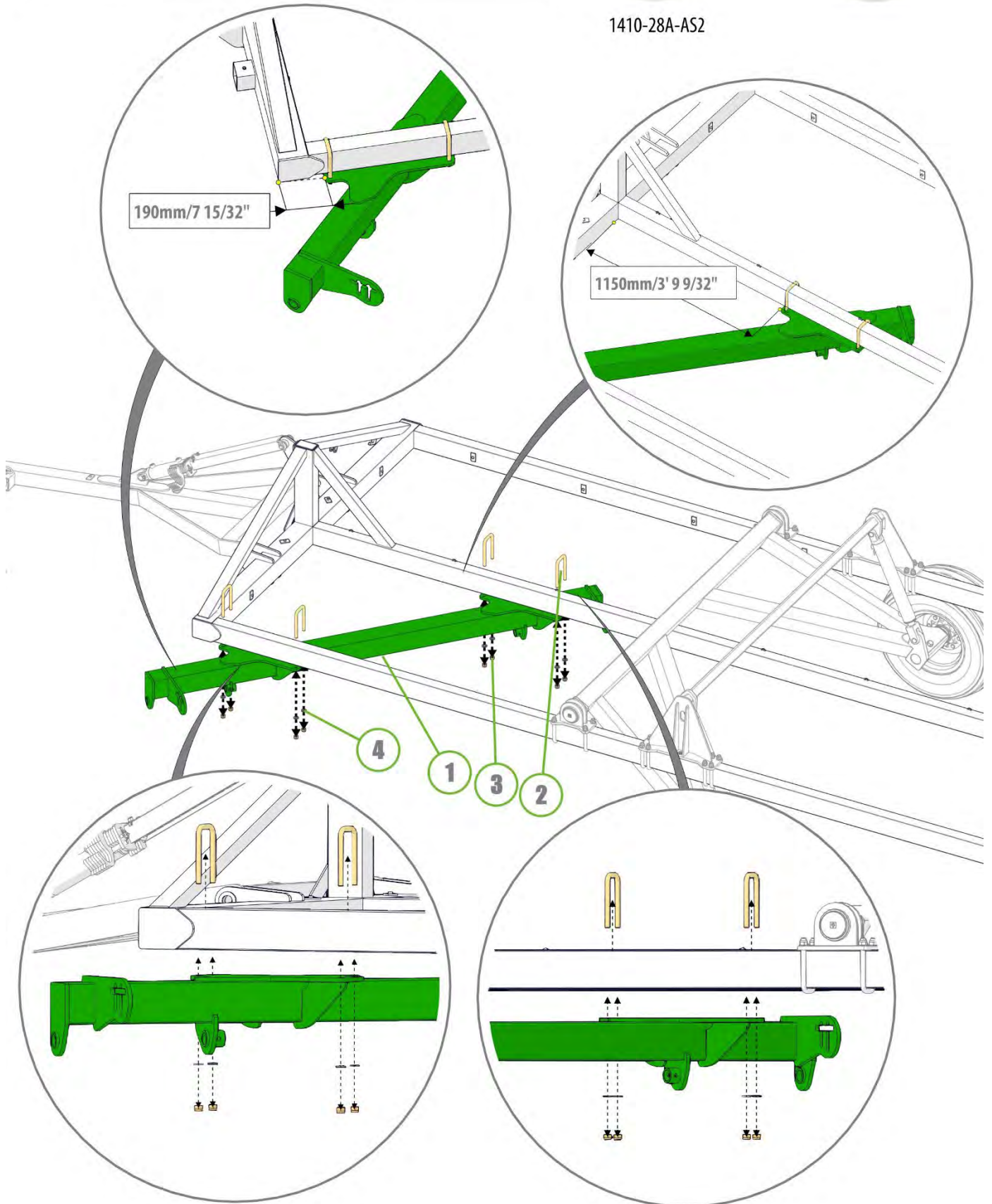

Item No.	Description	Number	Qty
1	Standard Chain Mount Plate	1610-20	1
2	Chain Mount Pivot Pin	0801-10-51	1
3	Washer High Tensile 1 3/8"	0232-HT13-8	1
4	Nyloc Nut M12	0221-NYL12	1
5	M12 x 65 Class 8.8 ZP Bolt	0211-1265	1



1410-28A-AS2

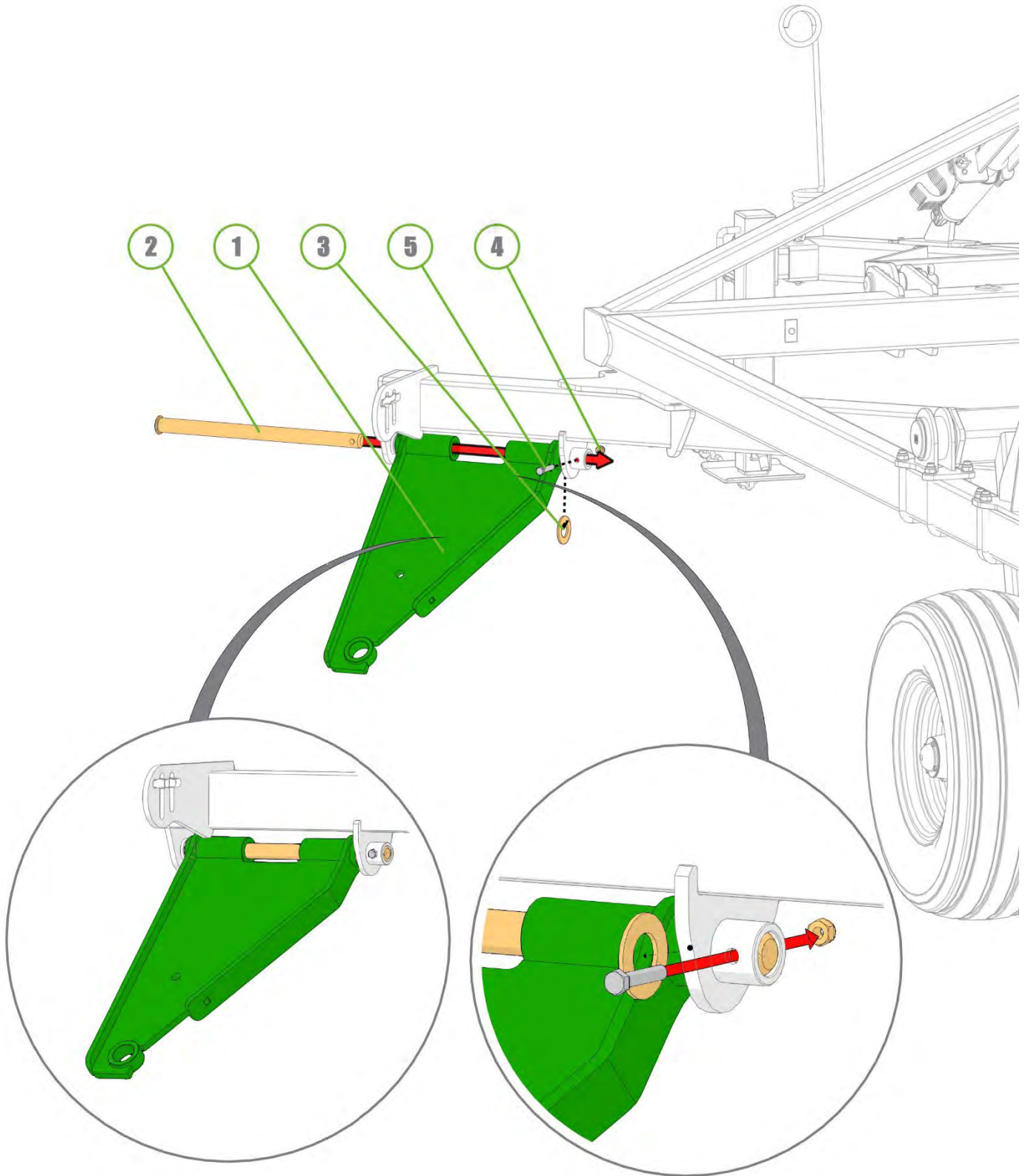

Item No.	Description	Number	Qty
1	Height Adjusting Chain Assembly 13 Link	0801-20MCA	1
2	Height Adjustor Retaining Clip	0801-KE014	1



1410-28A-AS2

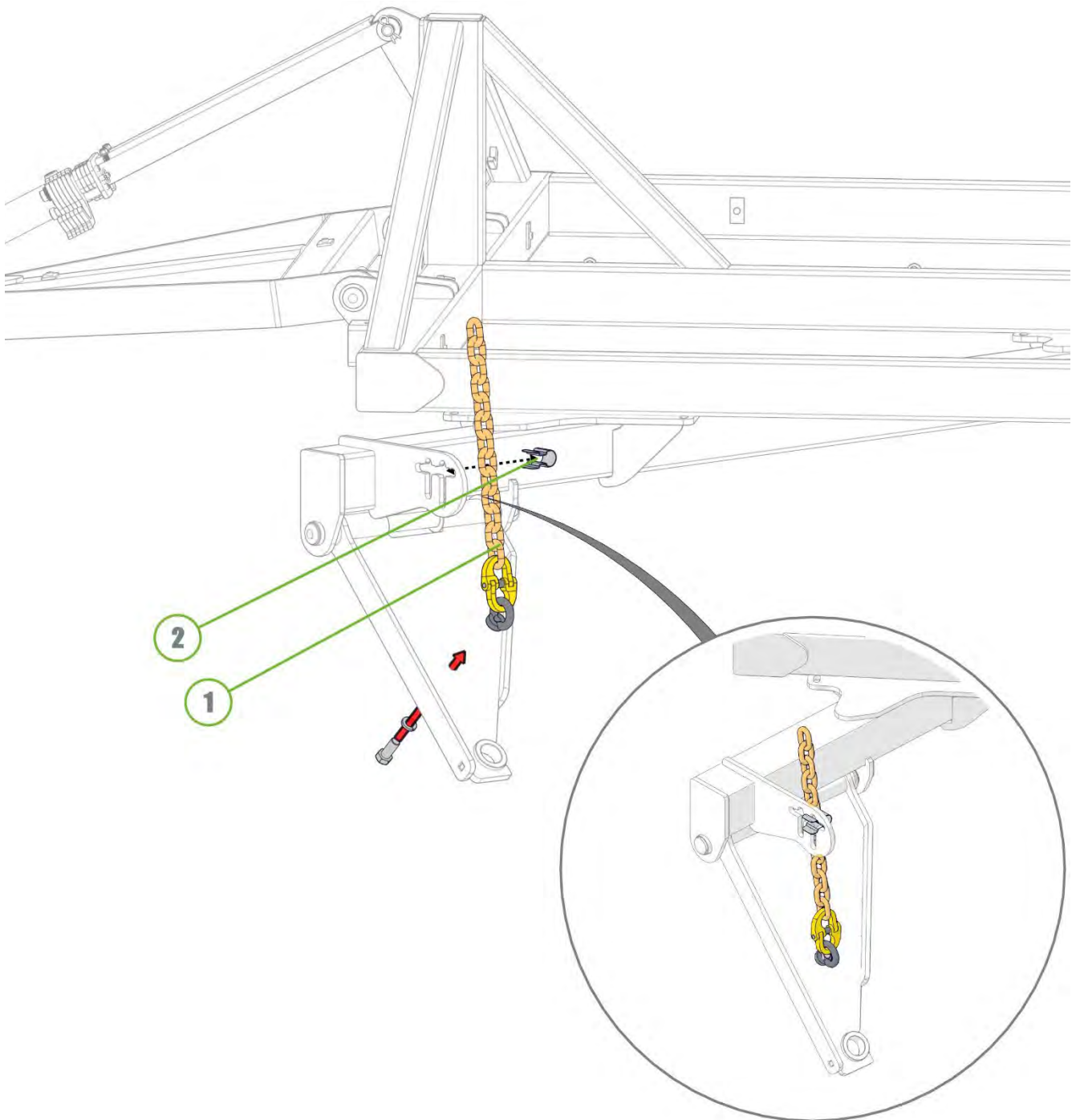

Item No.	Description	Number	Qty
1	Forged Clevis 21mm Bolt Hole	0801-FC21	1
2	M36 Grade 8.8 ZP Bolt	0211-36105	1
3	Wear Bush	1501-365033-SS	1
4	Nyloc Nut M36	0221-NYL36	1



1410-28A-AS2

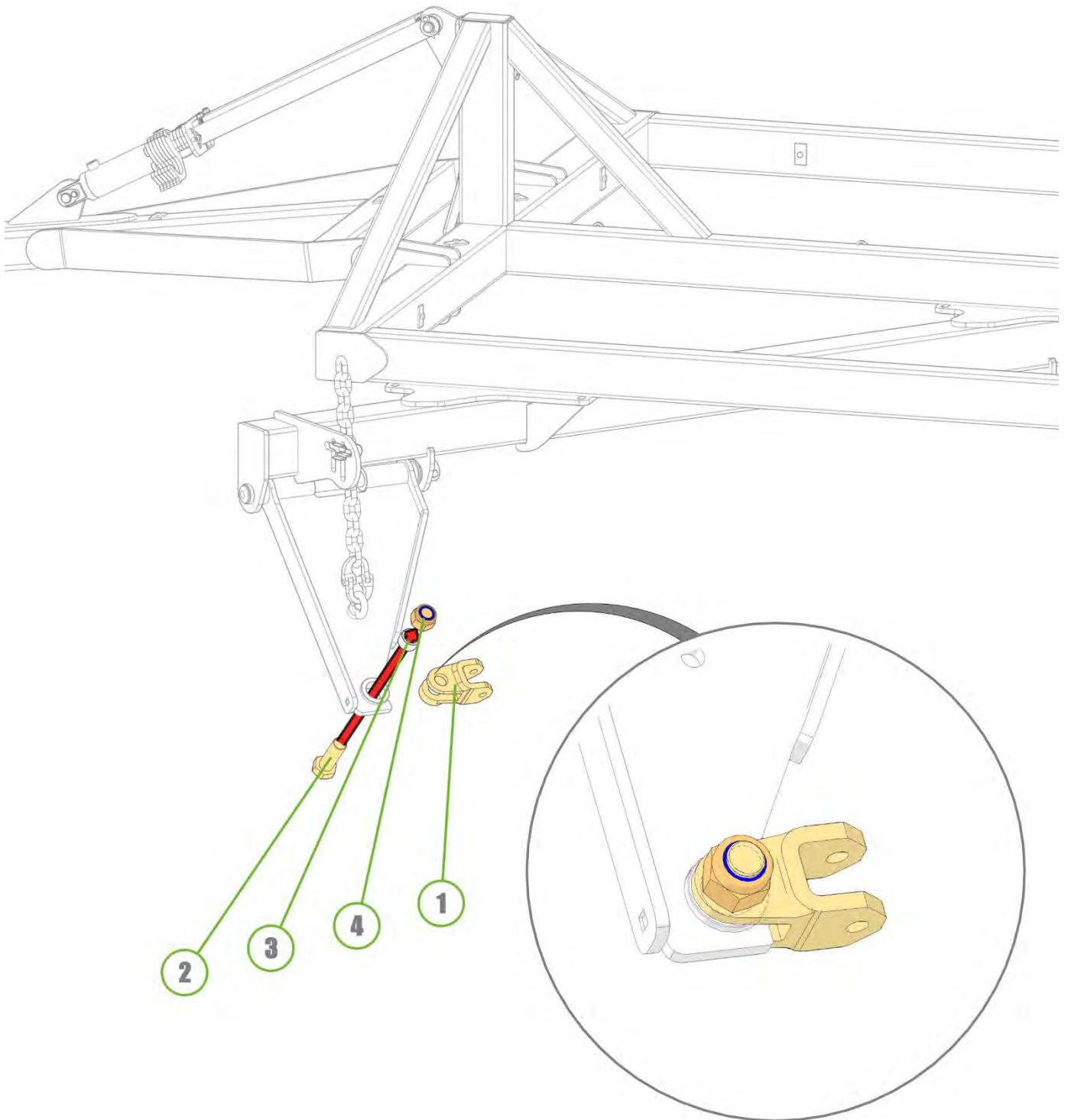

Item No.	Description	Number	Qty
1	20mm Bolt Swivel Unit	0802-PCHB55	1
2	M20 x 110 Class 10.9 ZP Short Thread Bolt	0211-20110ST	1
3	Nyloc Nut M20	0221-NYL20	1



1410-28A-AS2

Note: Ensure ALL clevis can pivot after installation

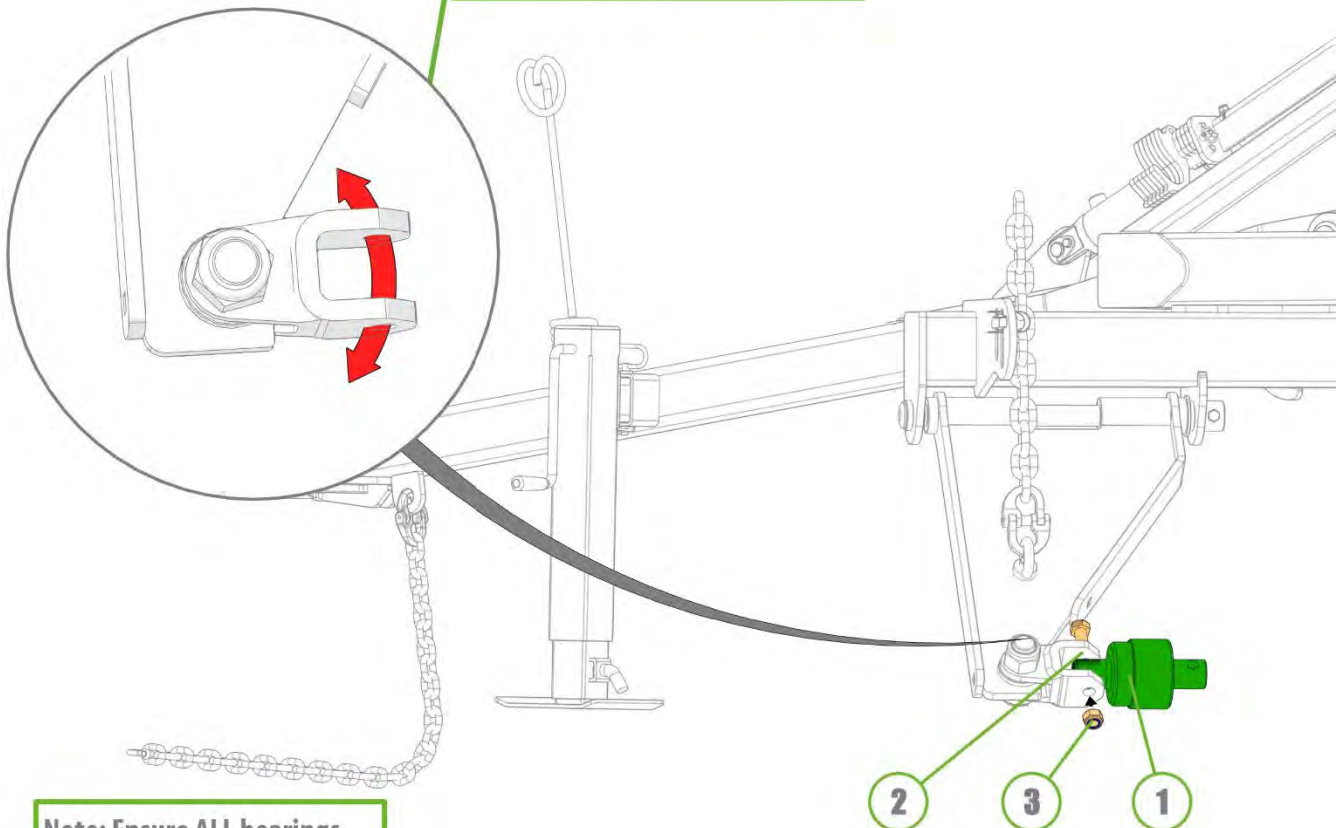

Note: Ensure ALL bearings are correctly orientated.

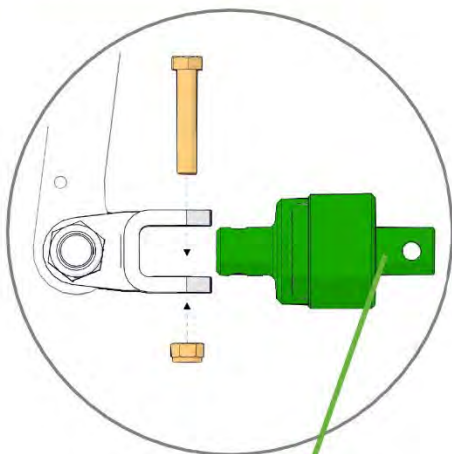

Rotating seal end of swivel should always face rearward

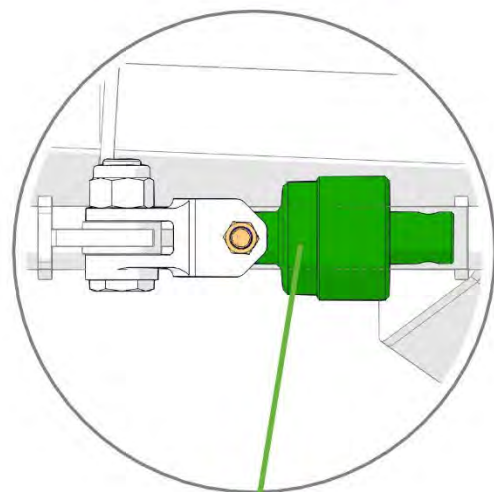

Fixed housing end of swivel should always face forward

Item No.	Description	Number	Qty
1	Tapered Chain End Hub	0810-45-5	1
2	TCE Blade Large	0800-767	1
3	TCE Blade Small	0800-766	1
4	Disc Chain Spacer	0801-253755	1
5	M20 x 110 Class 10.9 ZP Short Thread Bolt	0211-20110ST	2
6	M12 x 40 Coach Head Bolt	0215-CH1240	8
7	Nyloc Nut M12	0221-NYL12	8
8	Nyloc Nut M20	0221-NYL20	2
9	Washer Flat M12	0231-F12	8



1410-28A-AS2

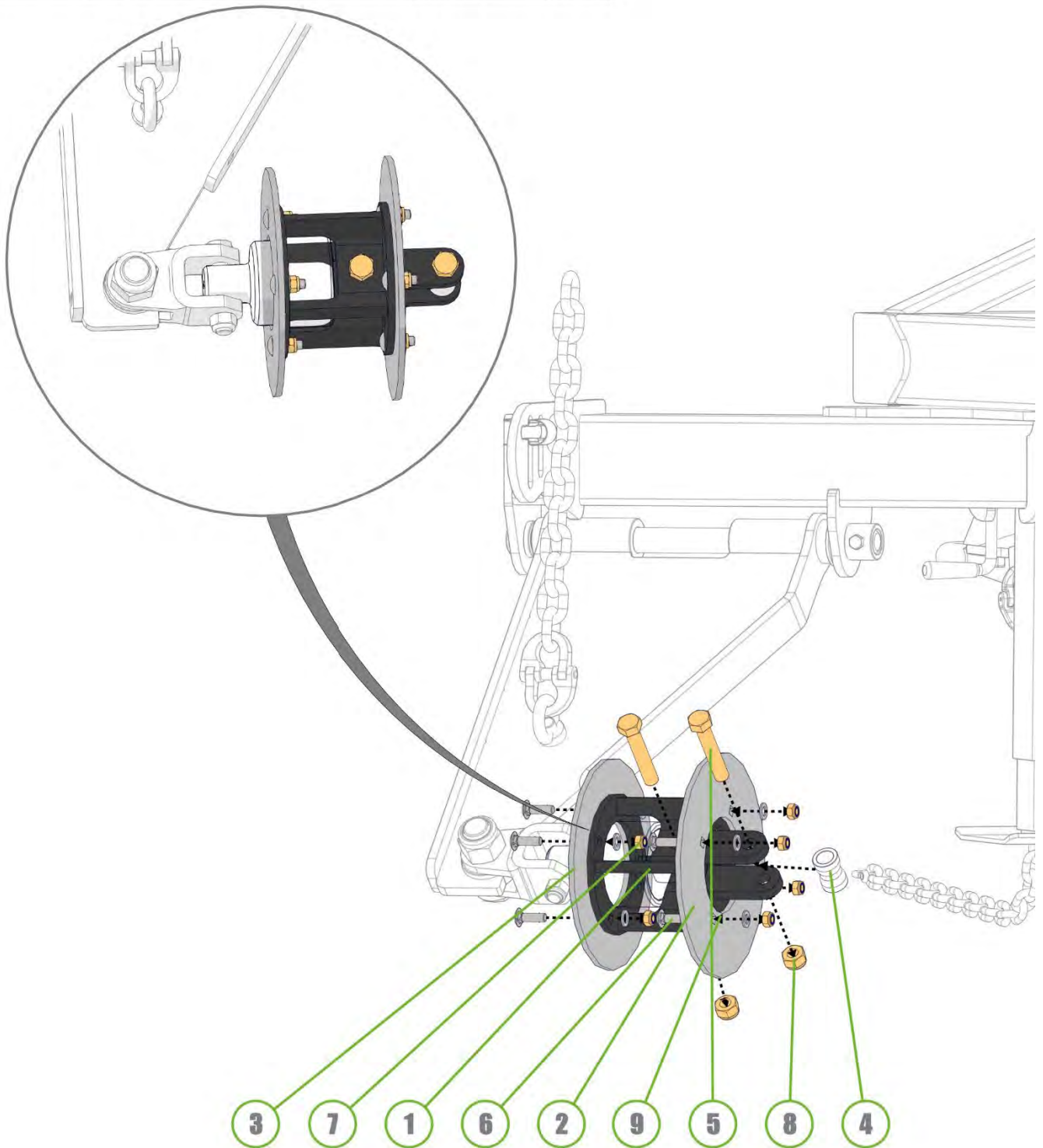

Item No.	Description	Number	Qty
1	Tension Box	0810-57	1
2	Height Adjusting Chain Assembly 13 Link	0801-20MCA	1
3	Chain Mount Pivot Pin	0801-10-51	1
4	Height Adjustor Retaining Clip	0801-KE014	1
5	M12 x 65 Class 8.8 ZP Bolt	0211-1265	1
6	Nyloc Nut M12	0221-NYL12	1
7	Washer High Tensile 1 3/8"	0232-HT13-8	1



1410-28A-AS2

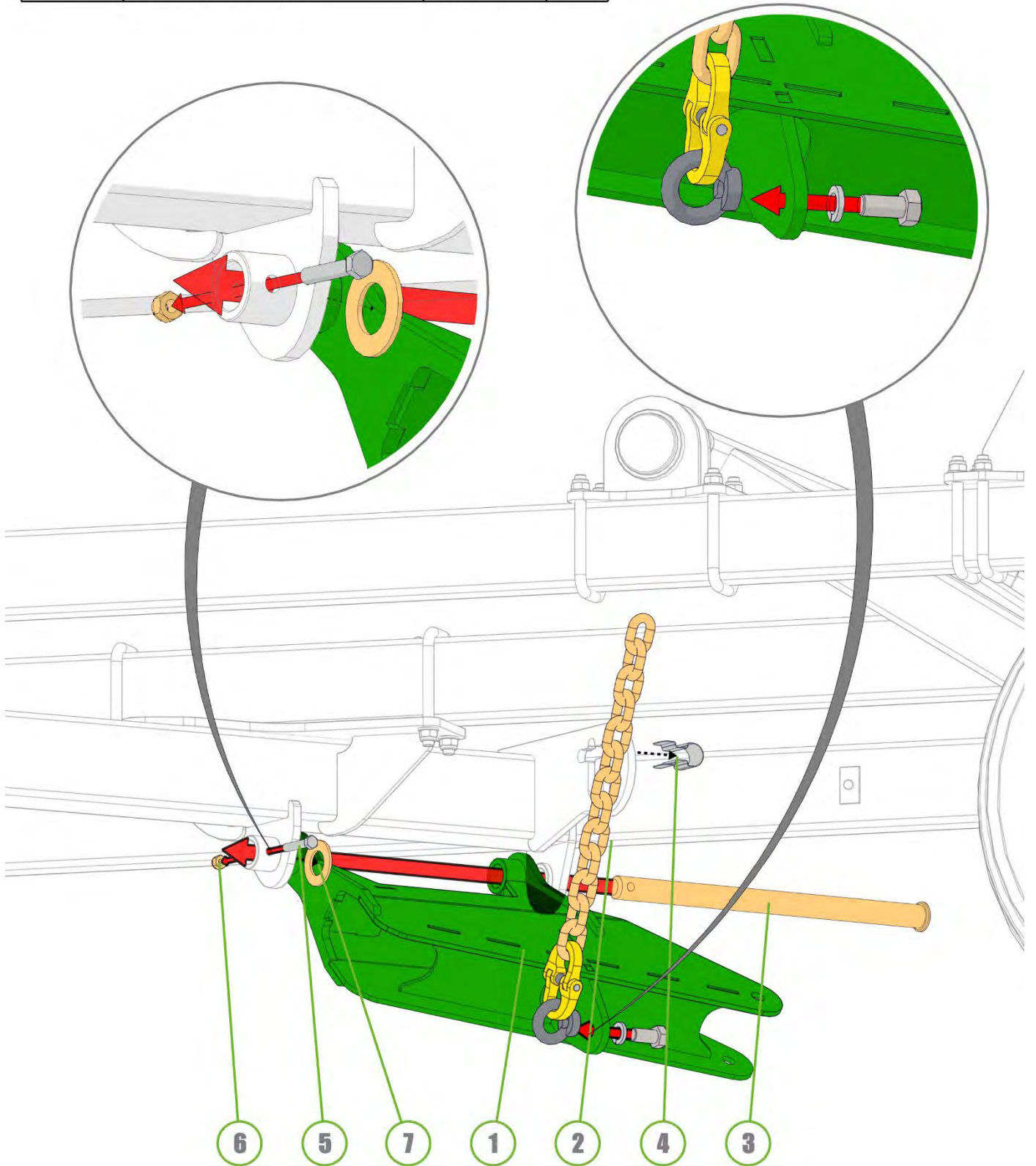

Item No.	Description	Number	Qty
1	Module Tension Rod Assembly	0810-105A	1
2	Heavy Duty Coil Spring 24mm	0801-K2455350	1
3	Rigid Spring Locator	0801-10-S2L	1
4	Washer High Tensile 1 1/4"	0232-HT11-4	1



1410-28A-AS2

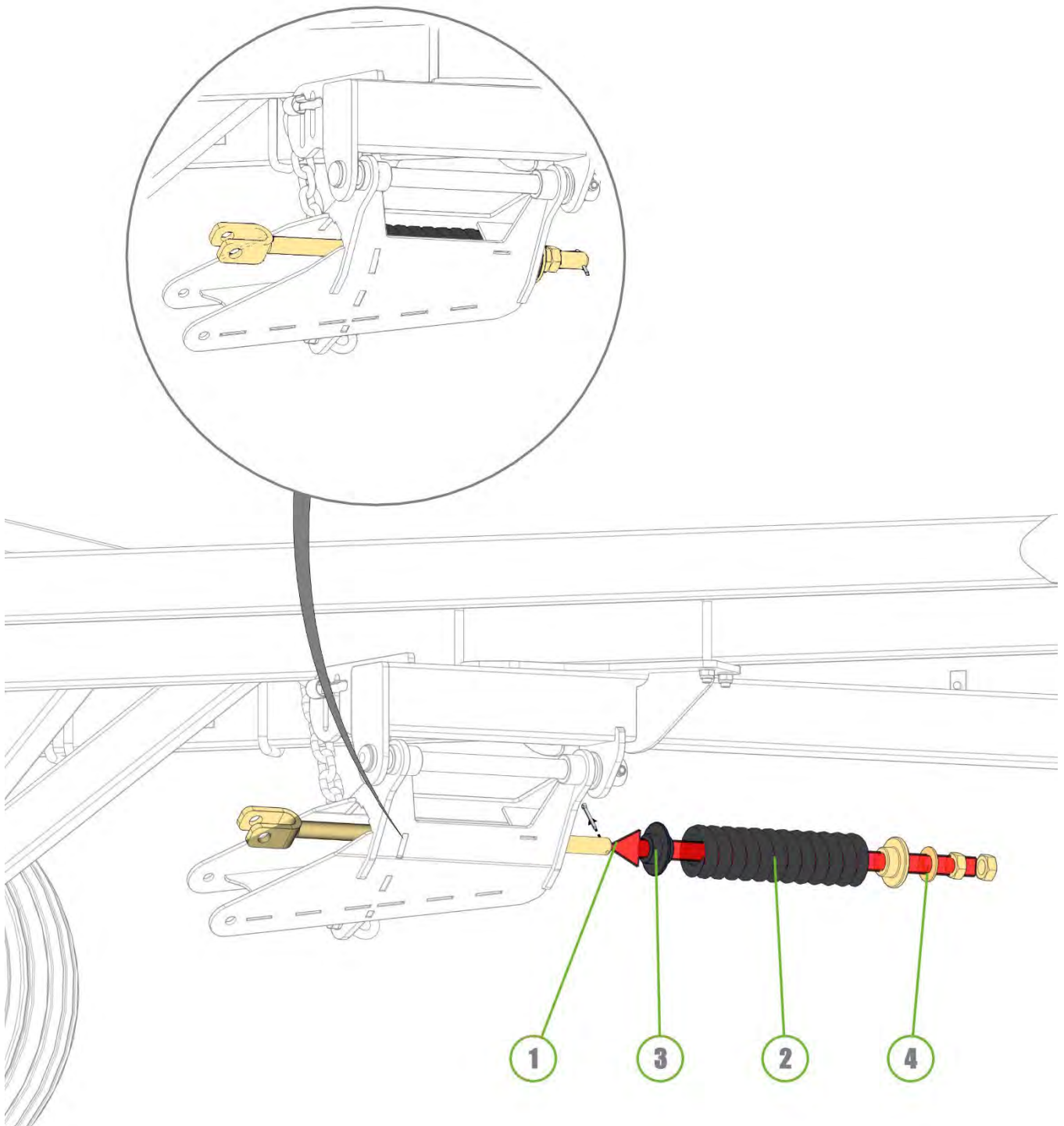

Item No.	Description	Number	Qty
1	Forged Clevis 21mm Bolt Hole	0801-FC21	1
2	M36 x 105 Class 8.8 ZP Bolt	0211-36105	1
3	Nyloc Nut M36	0221-NYL36	1
4	Wear Bush	1501-365033-SS	1
5	Chain Tension Arm	0810-104-3.5	1
6	Washer Flat 1"	0232-F1	1
7	M20 x 160 Class 8.8 ZP Bolt	0211-20160	1
8	Module Tension Rod Assembly	0810-105A	1
9	Nyloc Nut M20	0221-NYL20	1



1410-28A-AS2

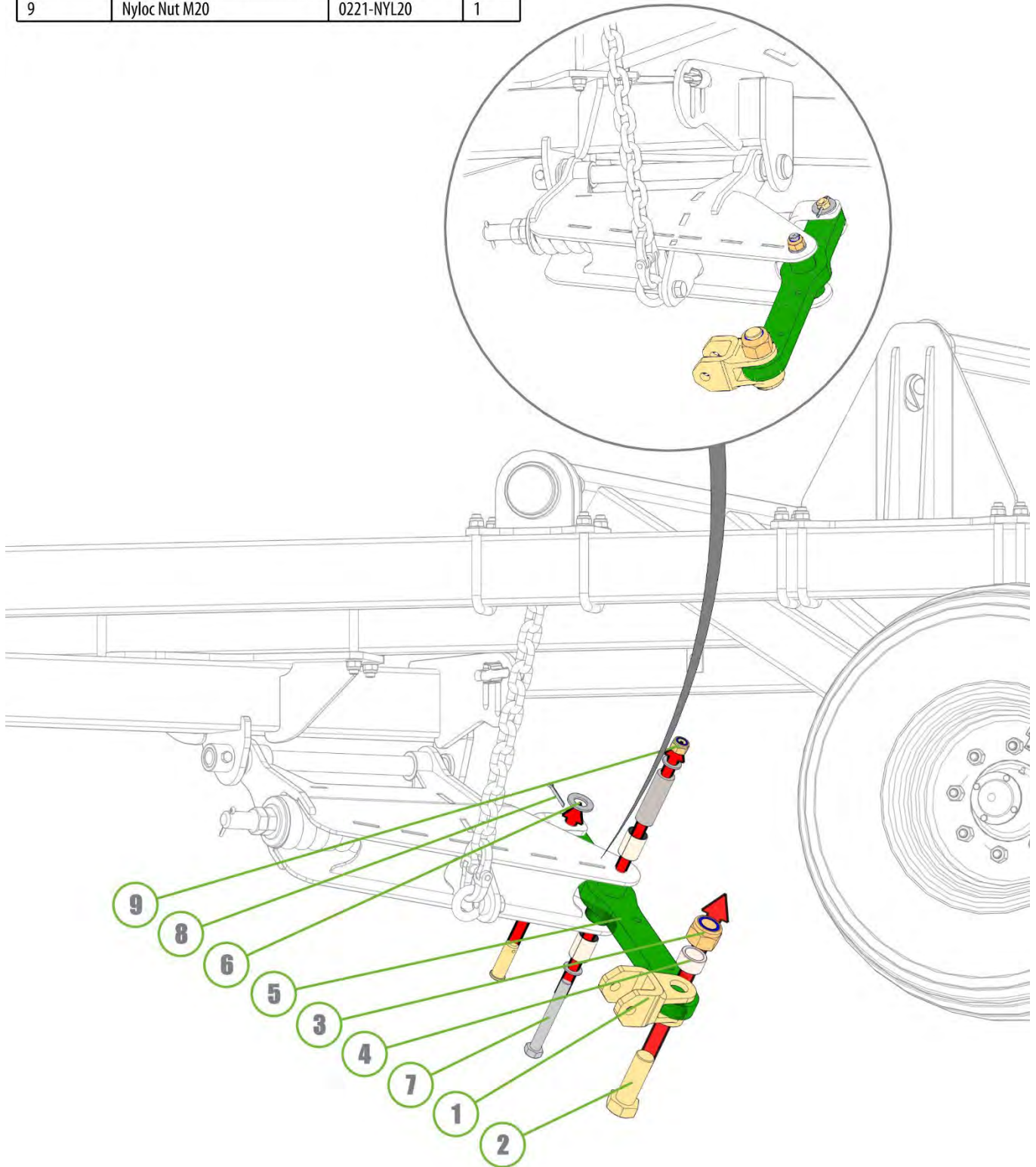

Item No.	Description	Number	Qty
1	20mm Bolt Swivel Unit	0802-PCHB55	1
2	Tapered Chain End Hub	0810-45-5	1
3	TCE Blade Large	0800-767	1
4	TCE Blade Small	0800-766	1
5	Disc Chain Spacer	0801-253755	1
6	M20 x 110 Class 10.9 ZP Short Thread Bolt	0211-20110ST	3
7	Nyloc Nut M20	0221-NYL20	2
8	M12 x 40 Coach Head Bolt	0215-CH1240	8
9	Nyloc Nut M12	0221-NYL12	8
10	Washer Flat M12	0231-F12	8



1410-28A-AS2

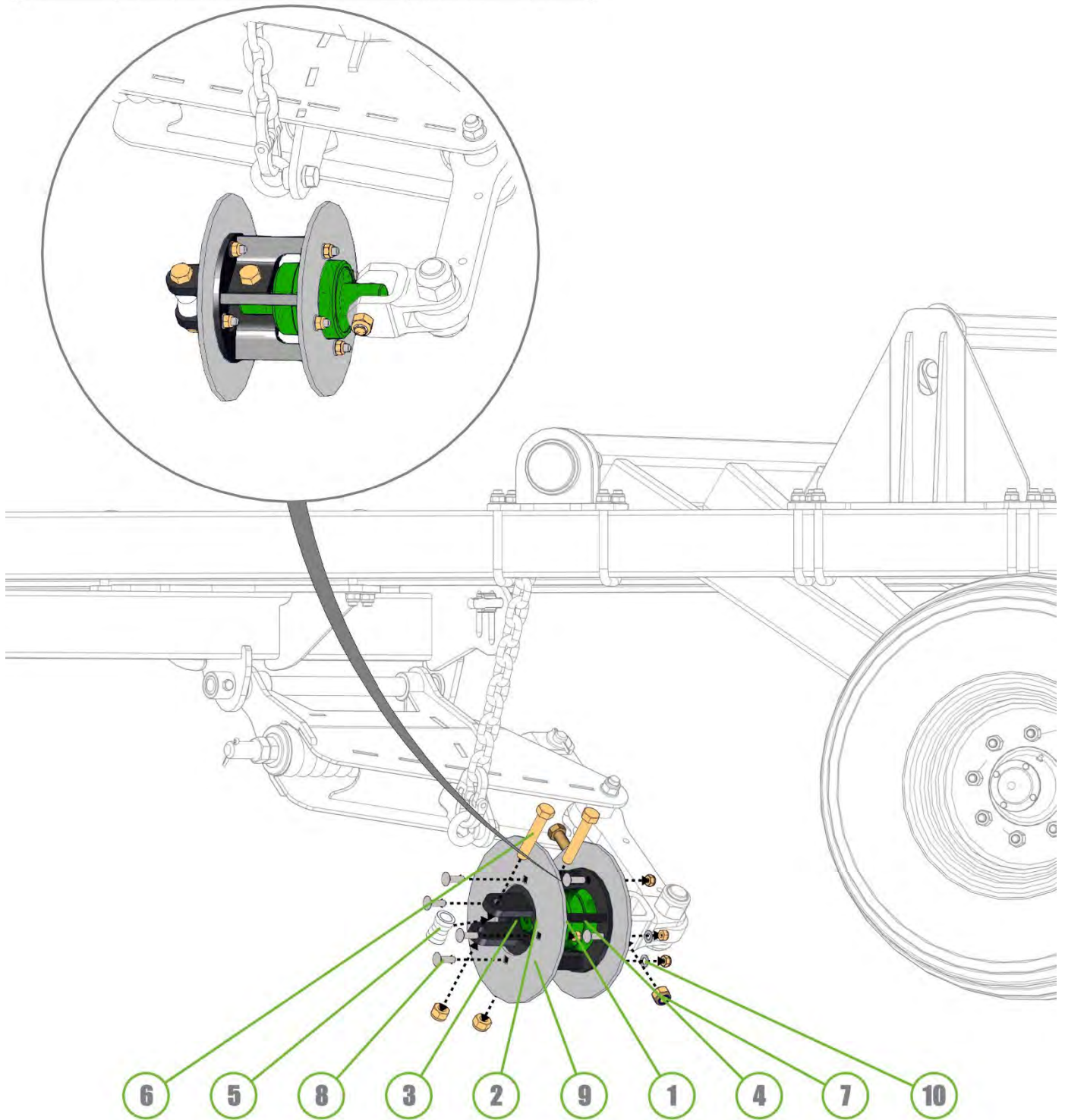

Item No.	Description	Number	Qty
1	Centre Module	1410-29-2	1
2	U-Bolt M16 x 167 Deep x 79 Wide	0271-1616077	6
3	Washer Flat M16	0231-F16	12
4	Nyloc Nut M16	0221-NYL16	12



1410-29A-AS2

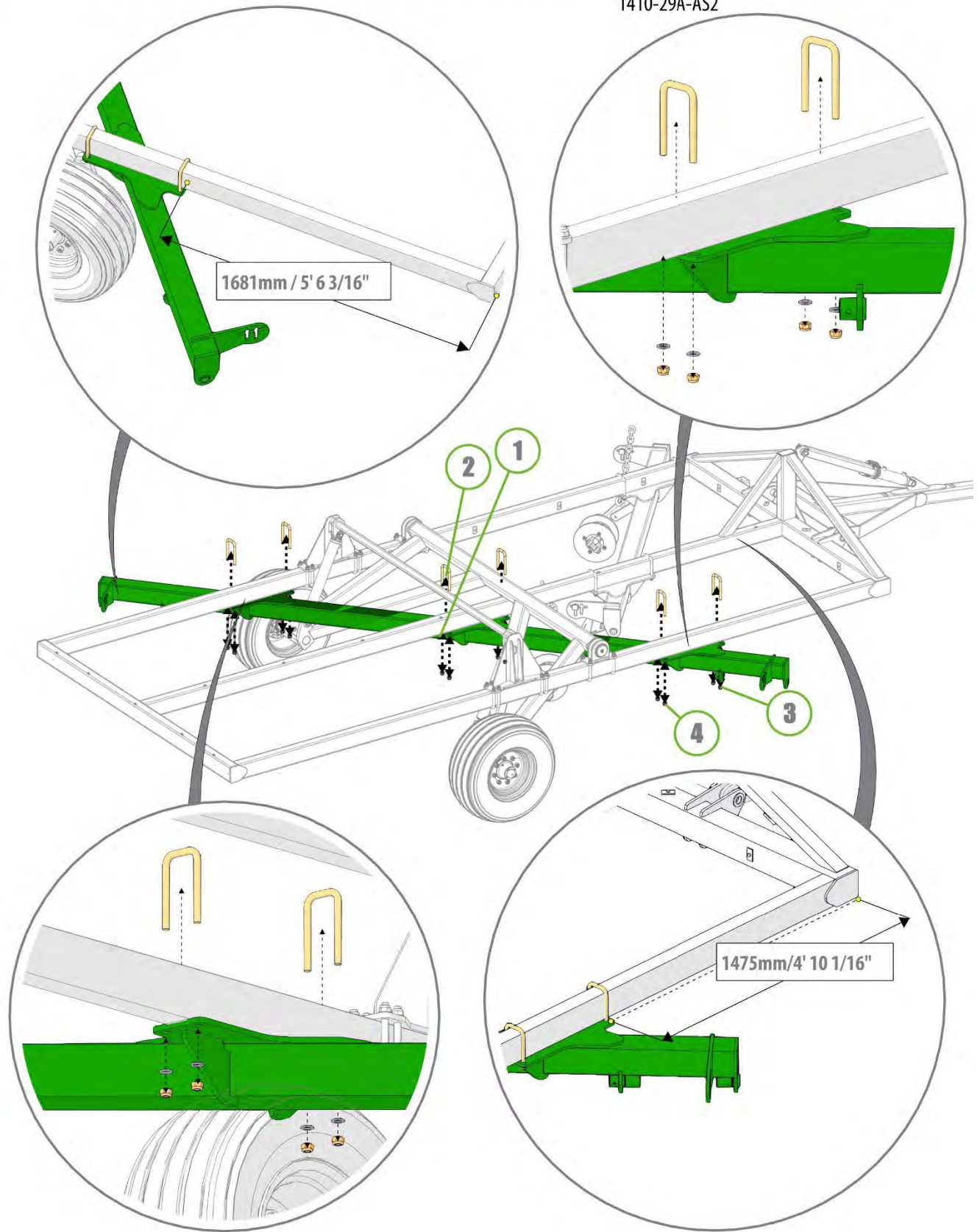

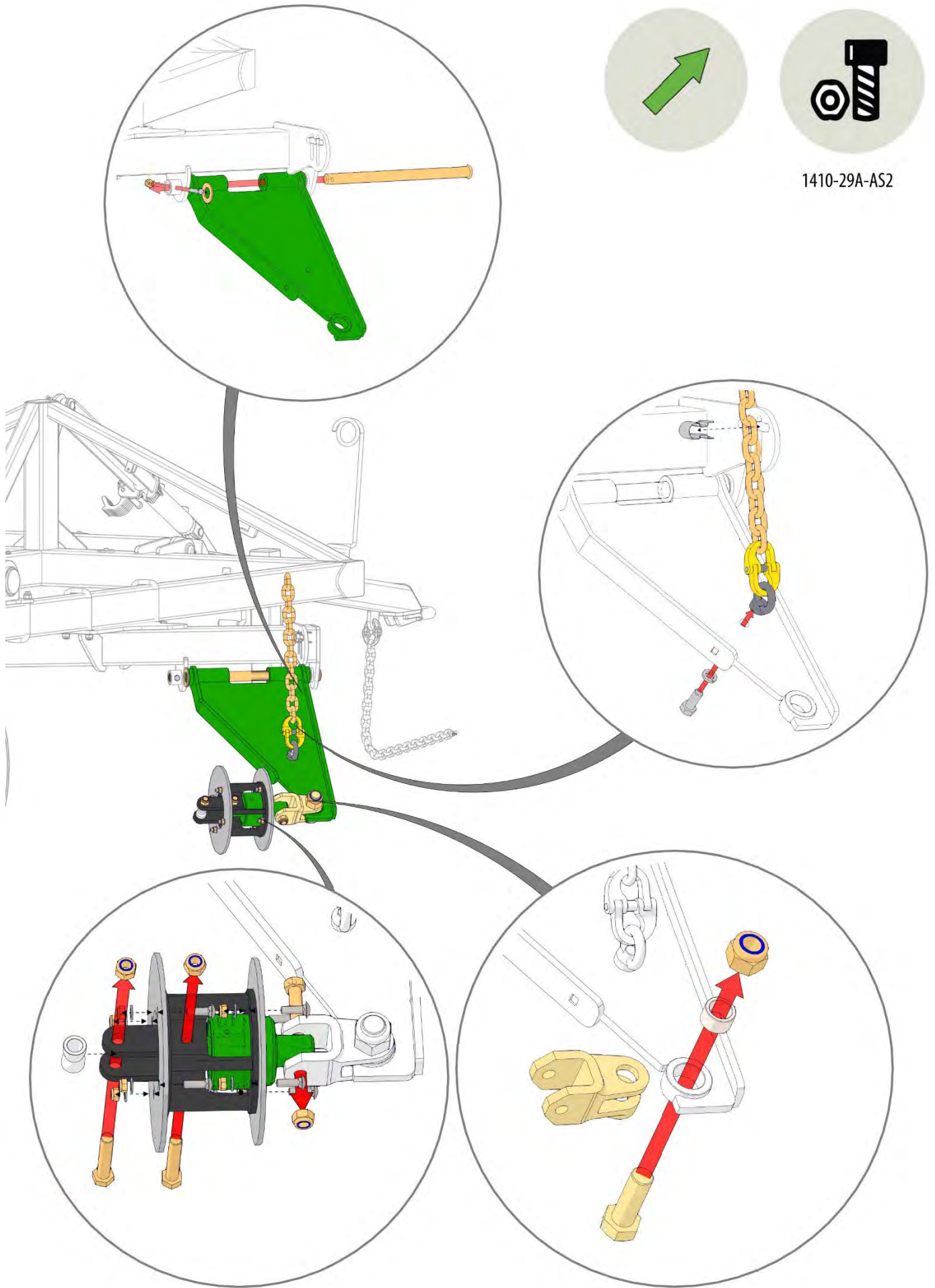

1410-29A-AS2



1410-29A-AS2

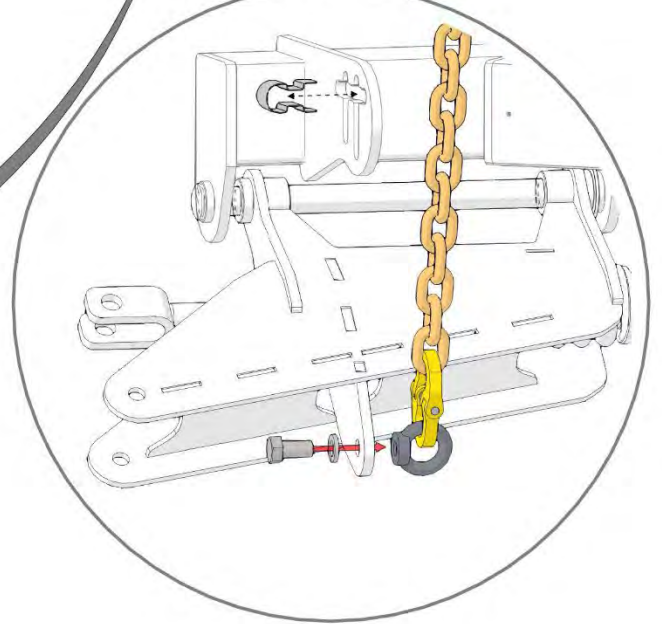
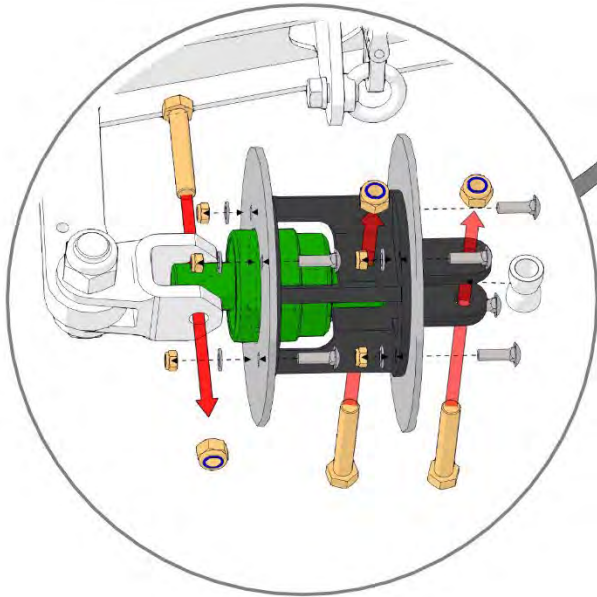
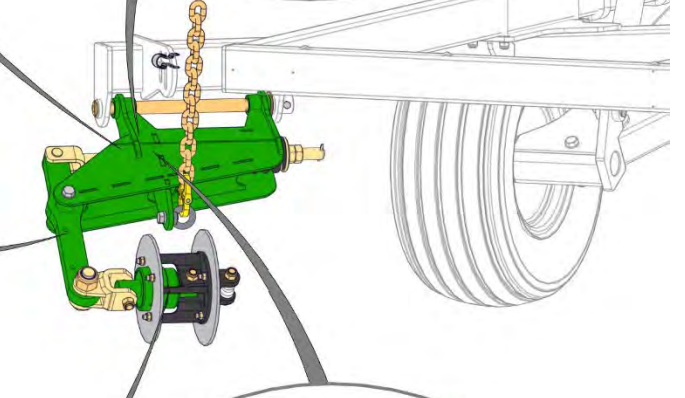
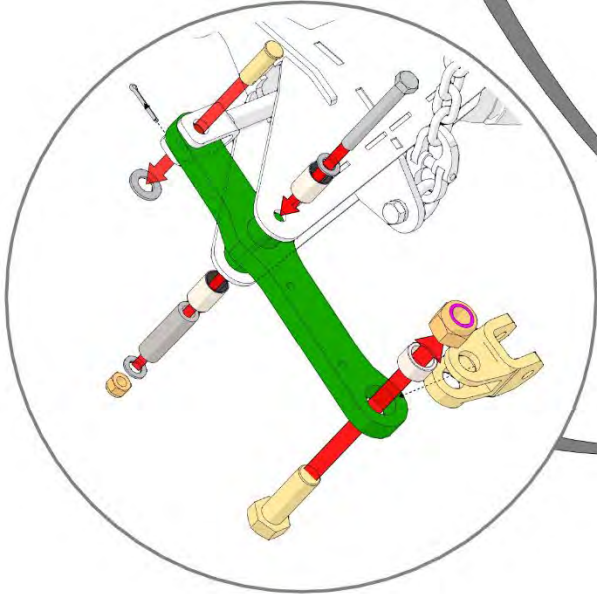
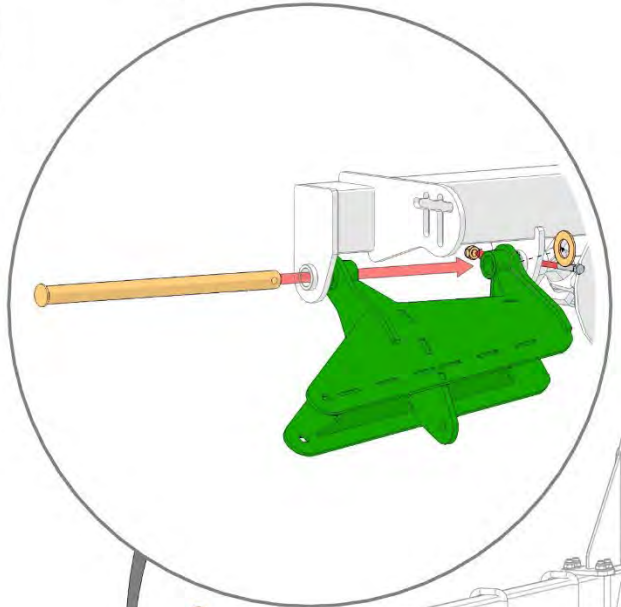
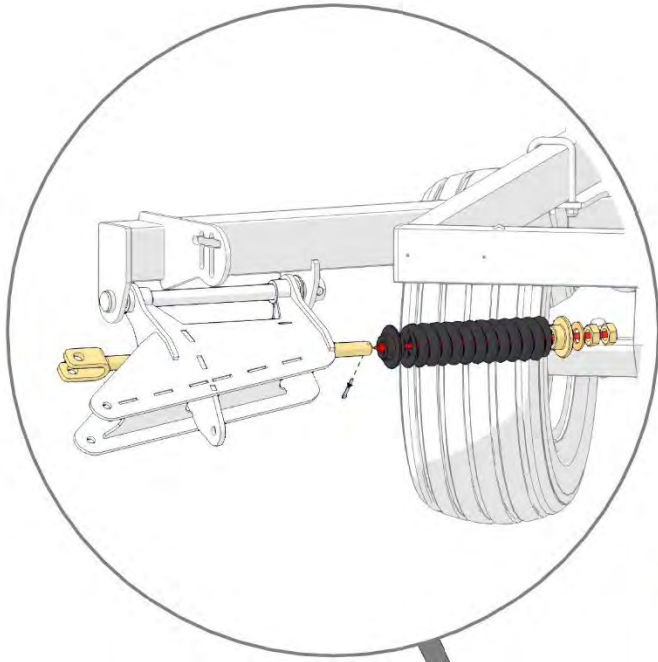

Item No.	Description	Number	Qty
1	Rear Module	1410-30-2	1
2	U-Bolt M16 x 167 Deep X 79 Wide	0271-1616779U	4
3	Nyloc Nut M16	0221-NYL16	8
4	Washer Flat M16	0231-F16	8



1410-30A-AS2

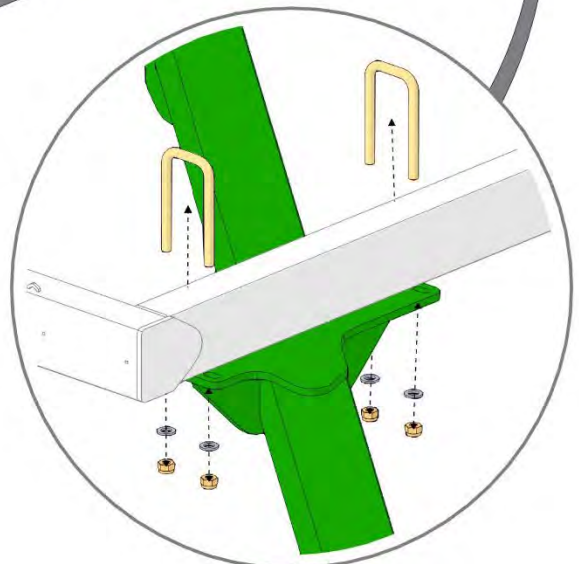
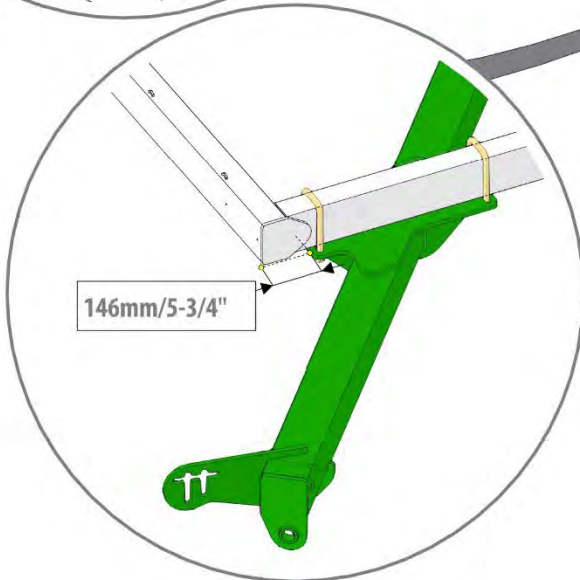
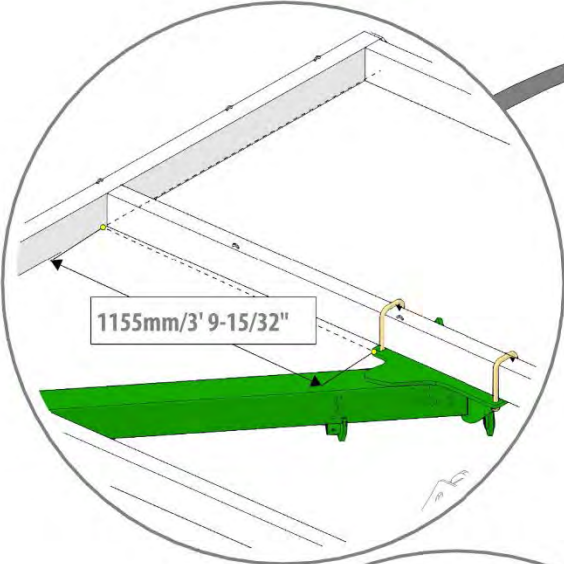
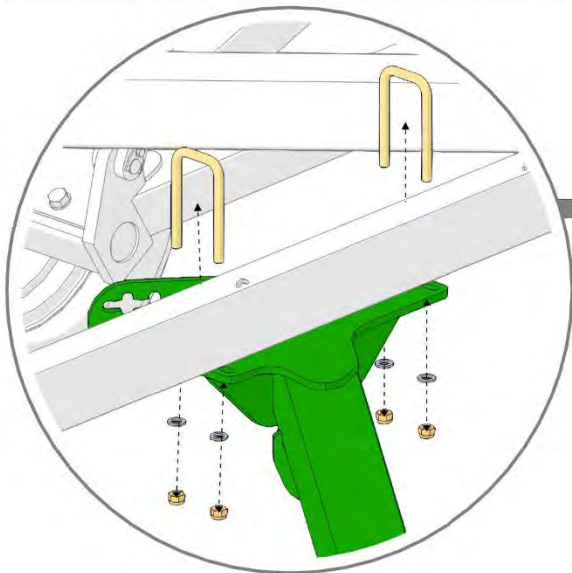
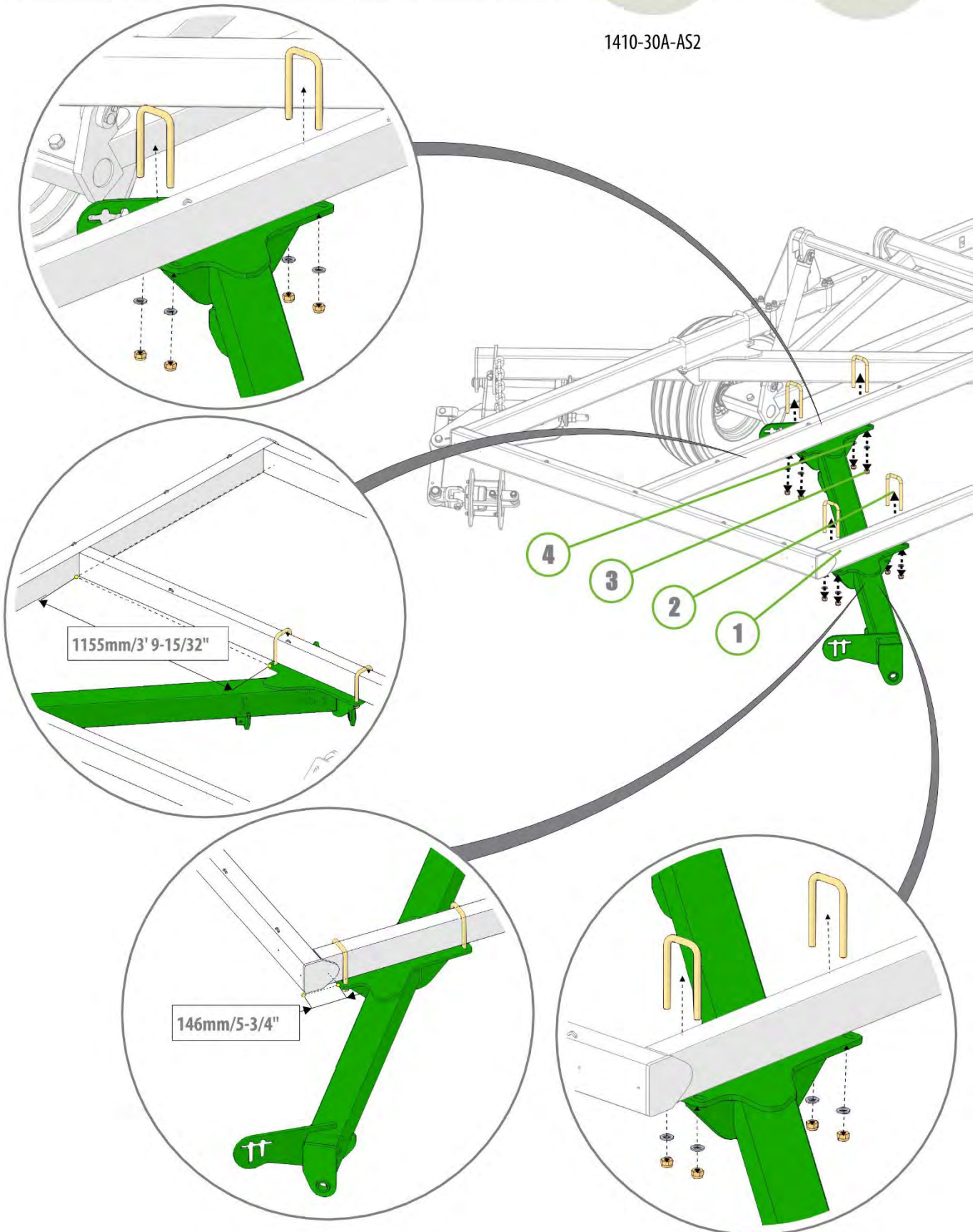

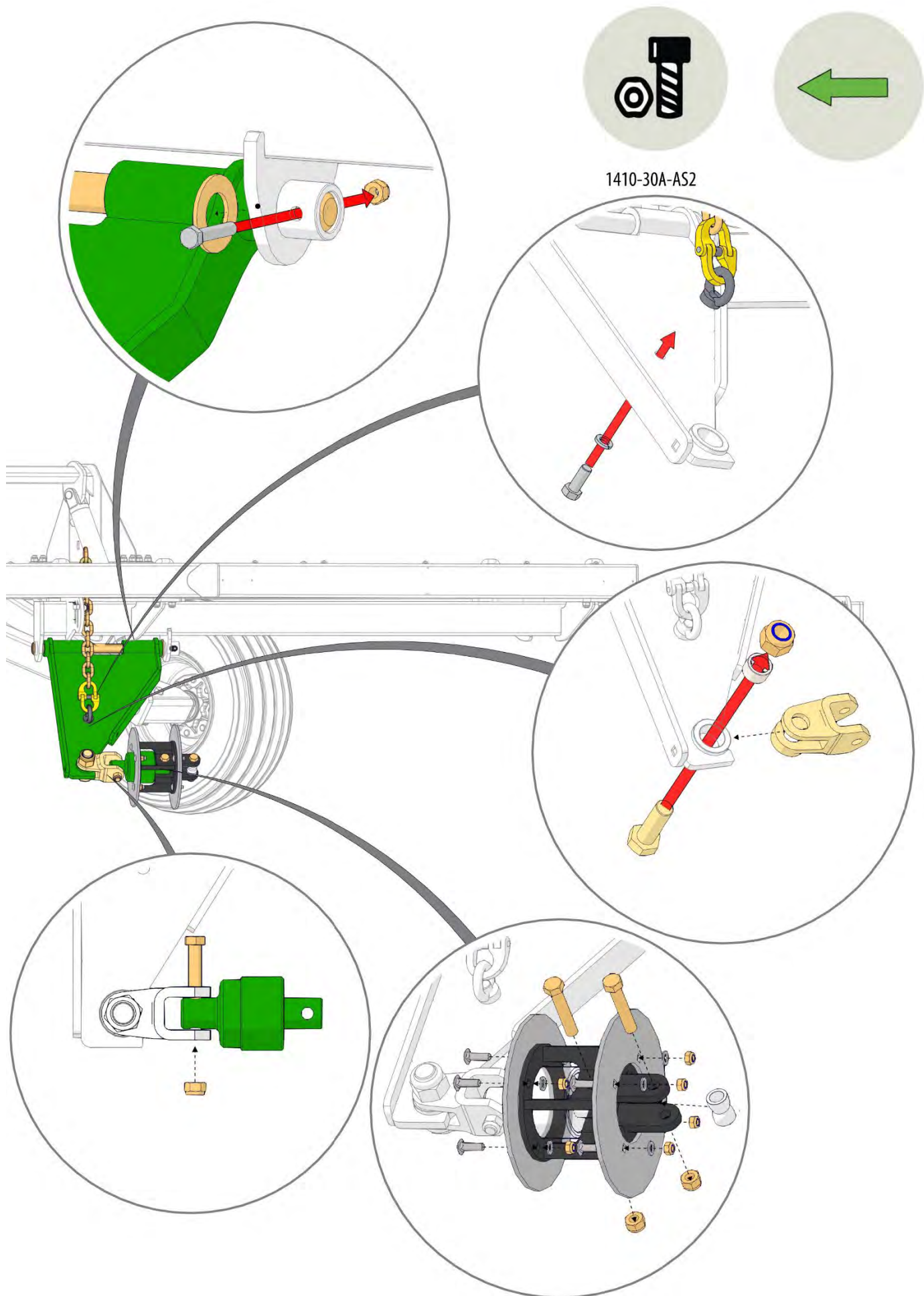

1410-30A-AS2

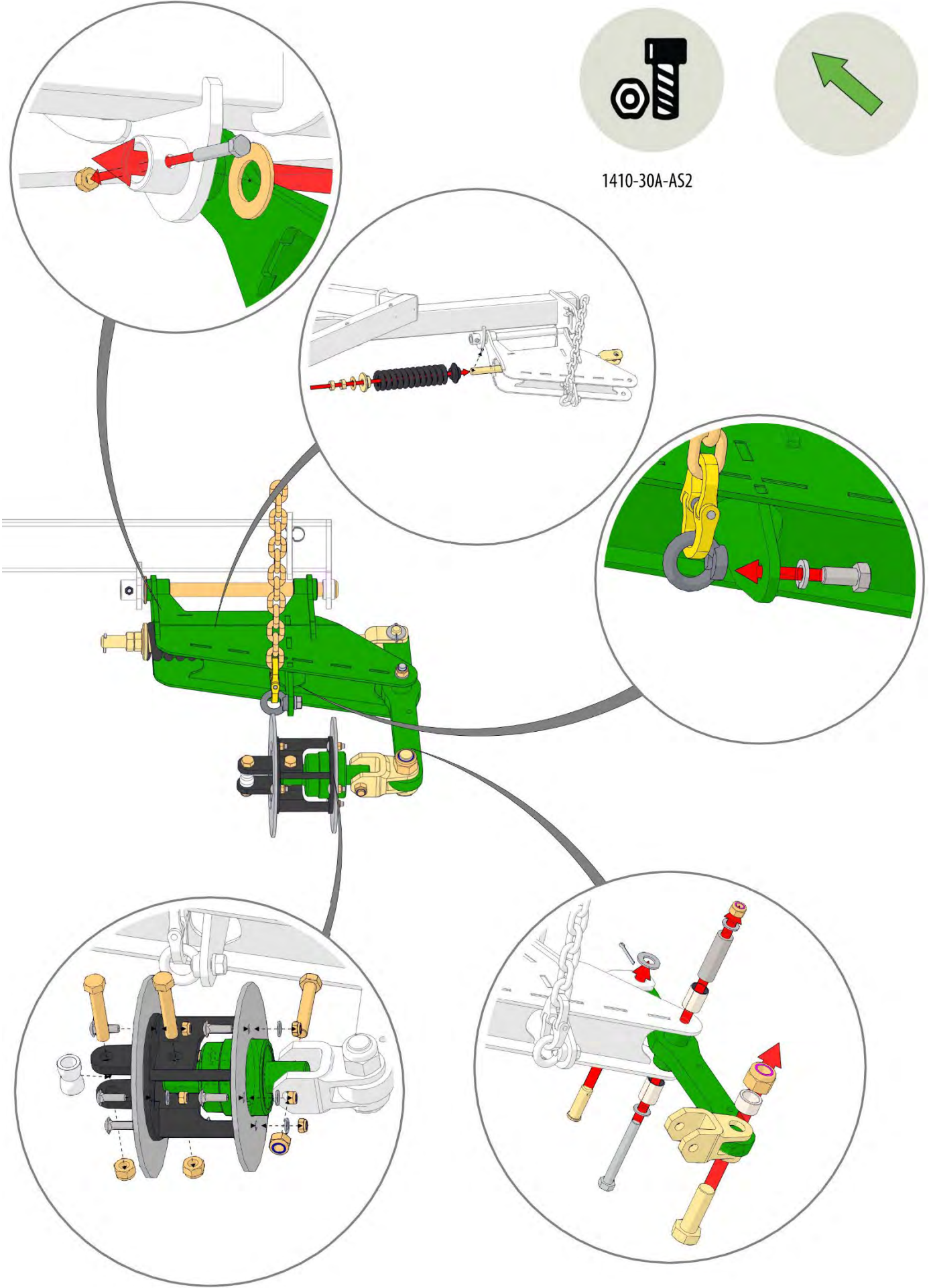

1410-30A-AS2

Item No.	Description	Number	Qty
1	M6 x 20mm Trilobe Screw	0211-M620MZPHTF	4
2	SMV Sign Bracket	0800-195.1	1
3	Slow Moving Vehical Sign	0801-FBSMVTUF	1



1410-01-2A-AS1

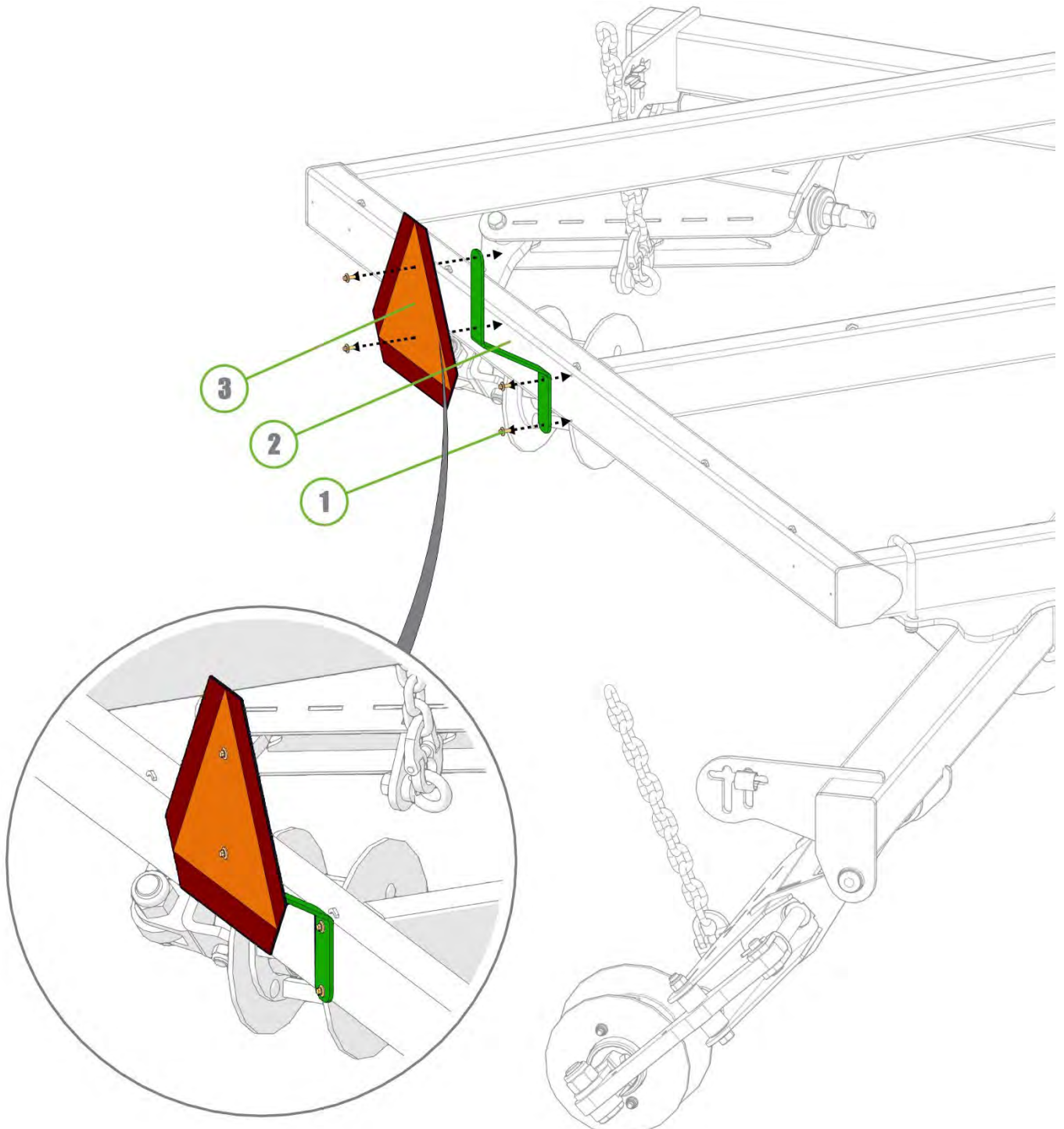

Item No.	Description	Number	Qty
1	Operator Manual Cannister	0801-OMC-1	1
2	M6 x 20mm Trilobe Screw	0211-M620MZPHTF	3
3	Ratcheting Gear Wrench 1 3/4"	0802-GW1 3-4	1
4	Square Loop Pin M8 x 63	0511-PINLOOPSQ863	1



1410-01-2A-AS1

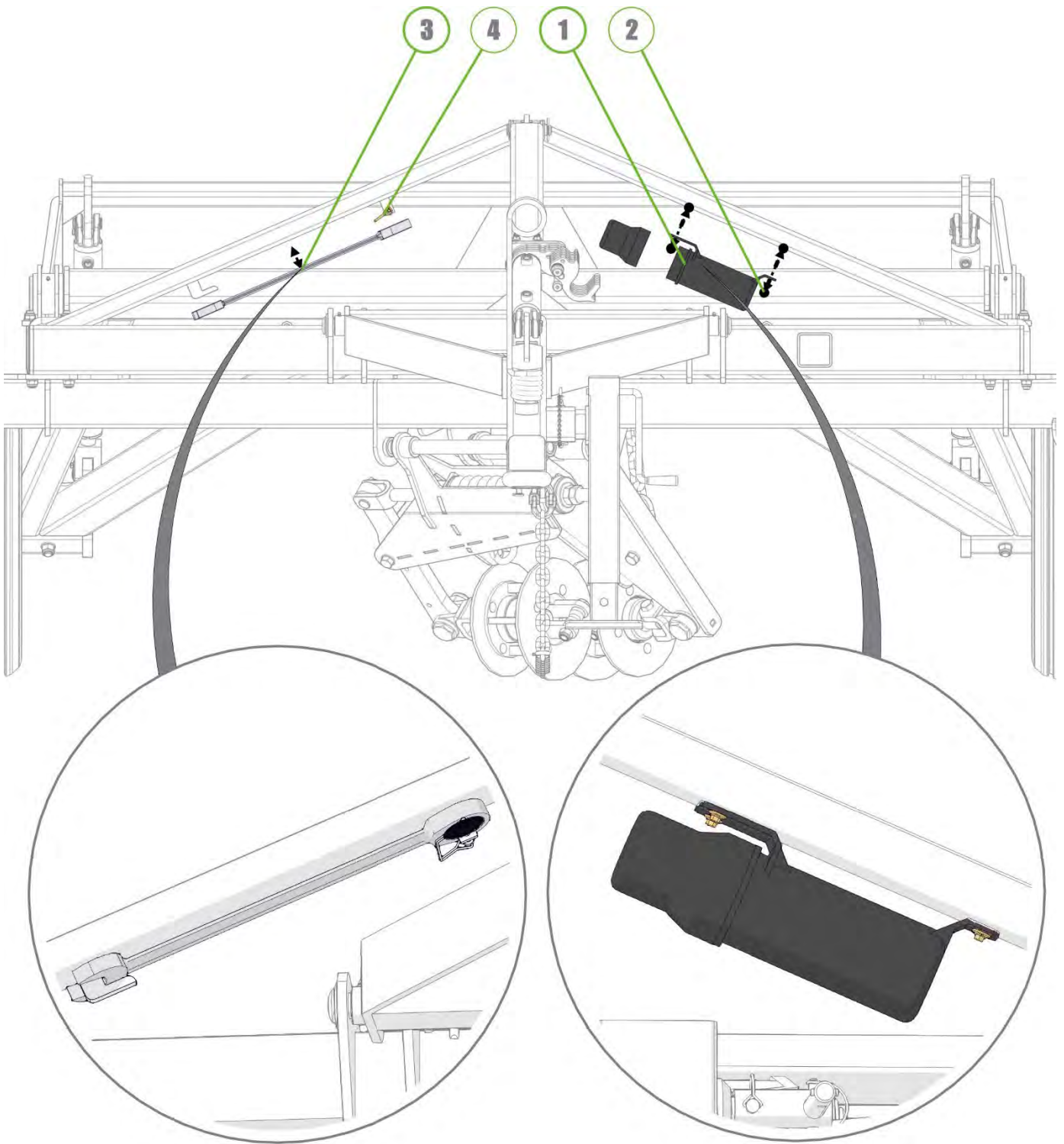

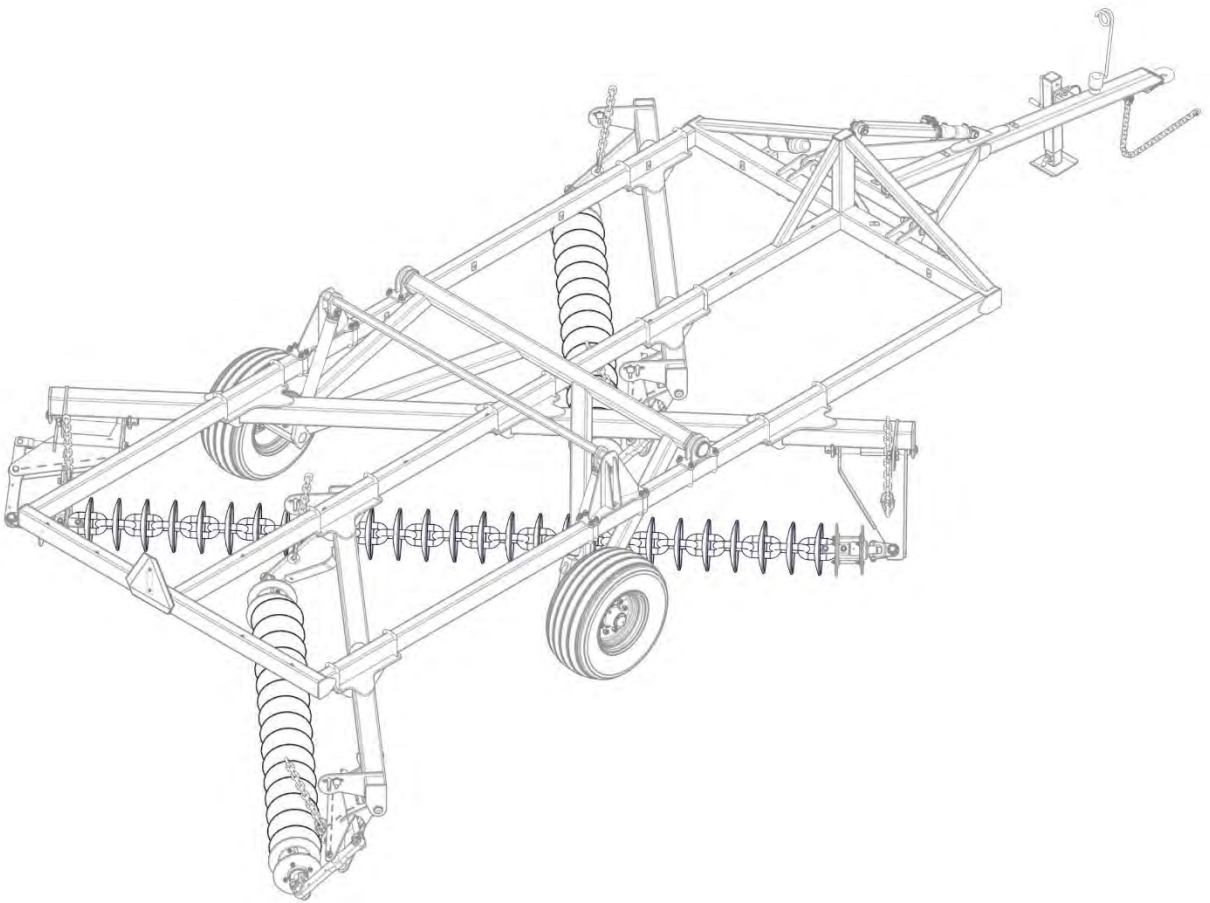



SECTION 3
HYDRAULICS

SECTION 3 HYDRAULICS

Item No.	Description	Number	Qty
1	RCD Double Clamp Bolt No 2	0325-RCD-2BH	1
2	RCD Double Clamp Jaws 17mm	0325-RCD-17J	1
3	RCD Double Clamp Top Plate No 2	0325-RCD-2PT	1

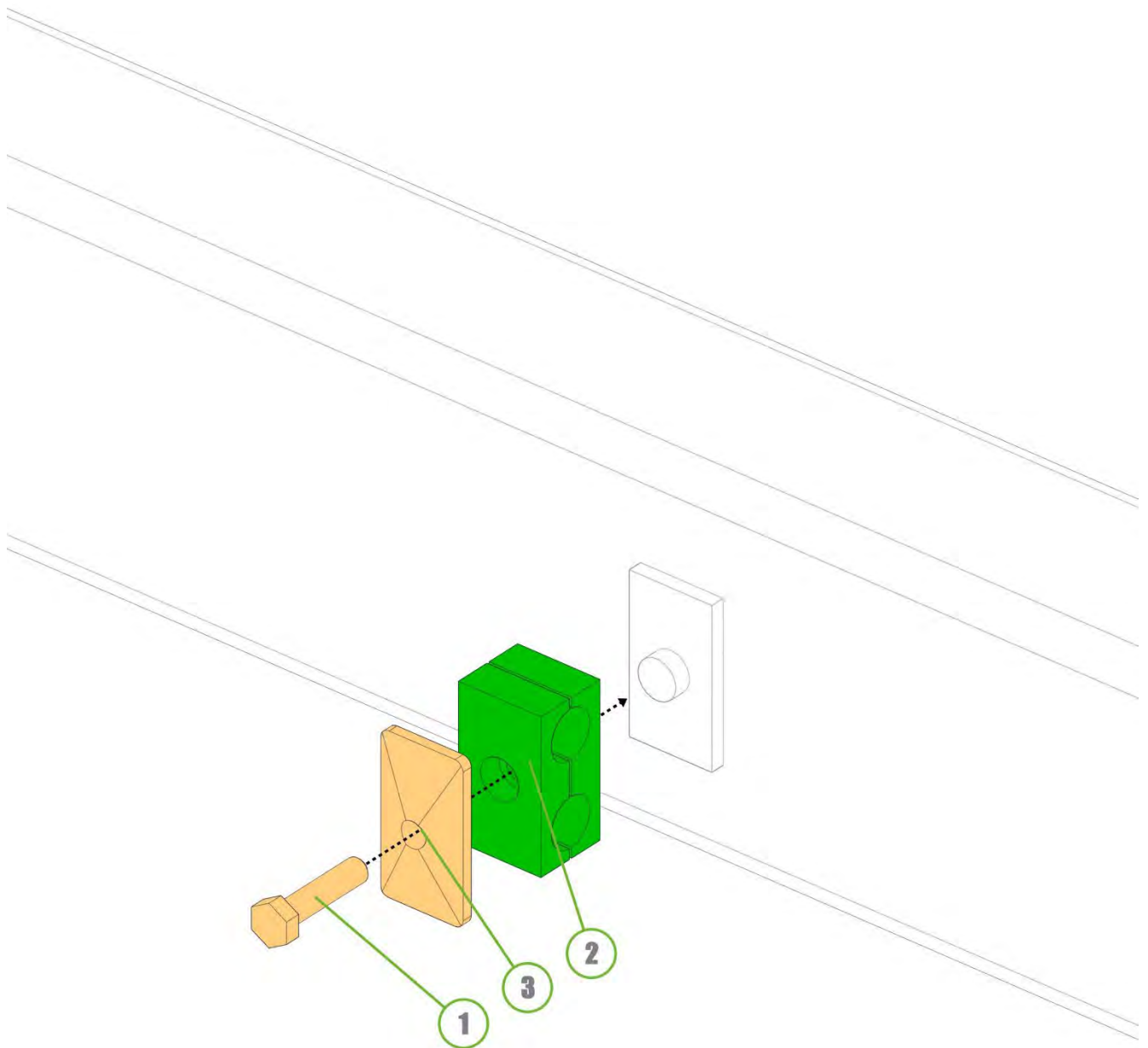

Item No.	Description	Number	Qty
1	3/4" JIC Male 3/4" UN O Ring Male 90° Elbow	0323-S91-1212	2

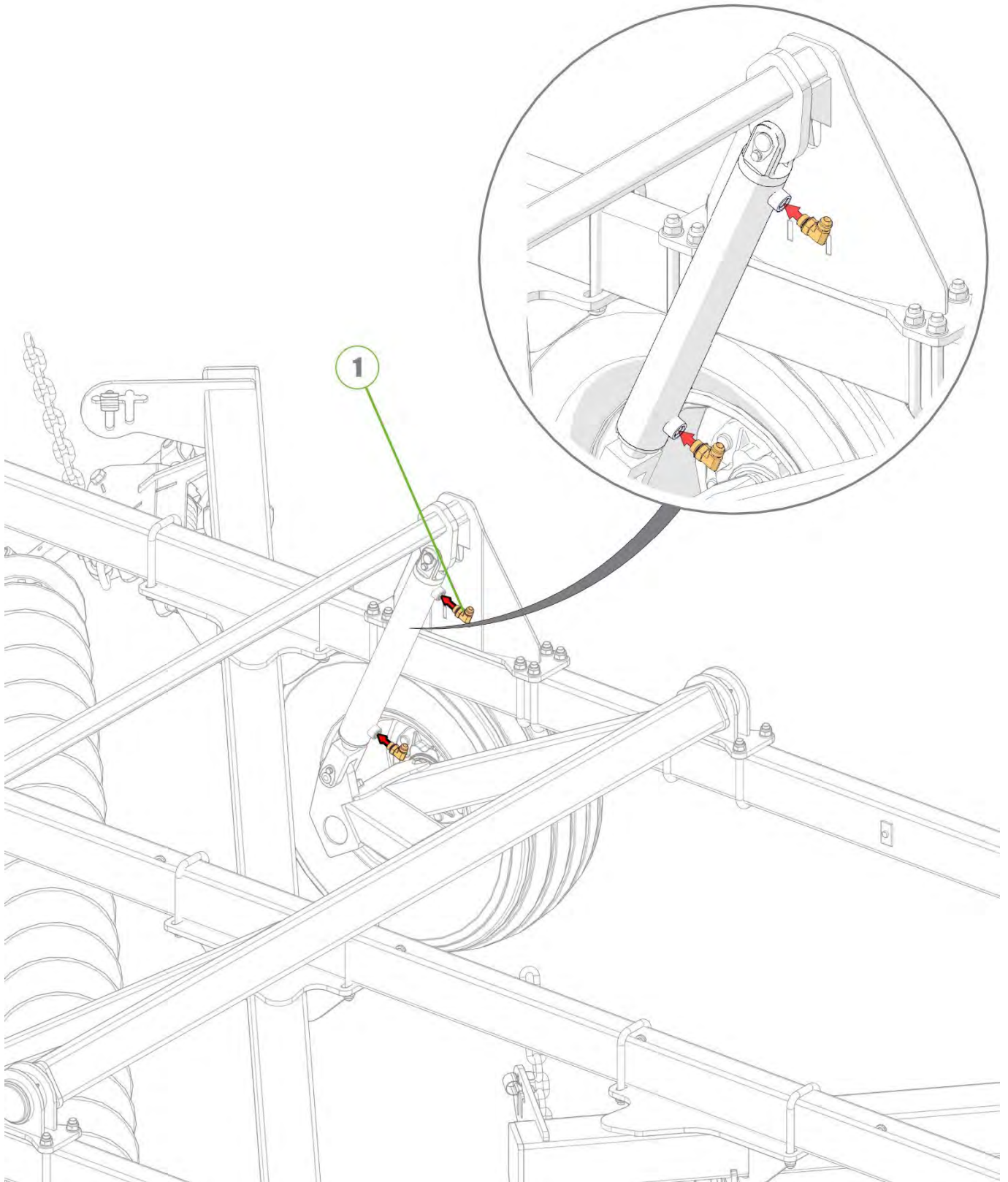

Item No.	Description	Number	Qty
1	Extend Tee To Extend Port of LH Lift Cylinder	1402-HK-04	1
2	Retract Tee To Retract Port of LH Lift Cylinder	1402-HK-05	1

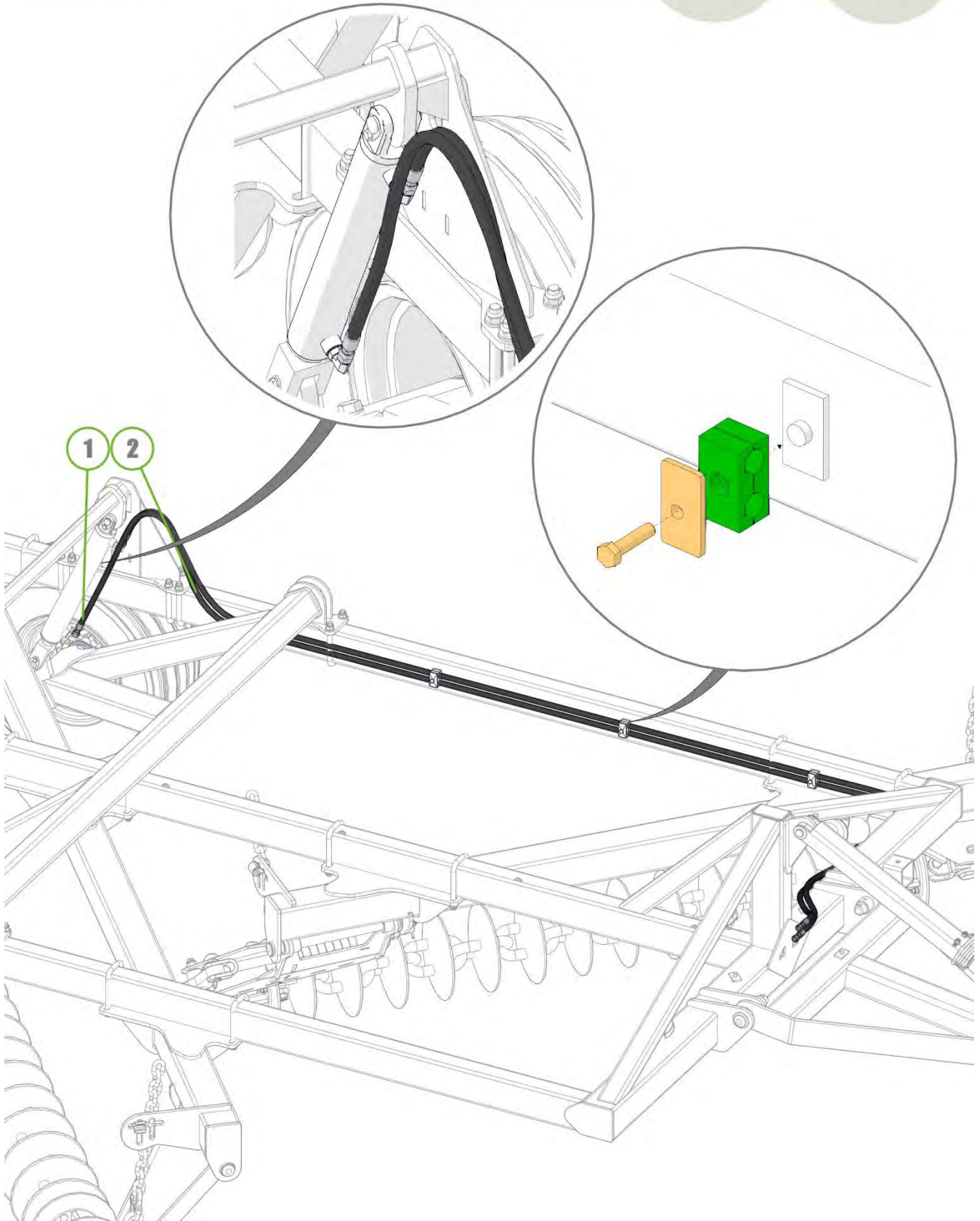
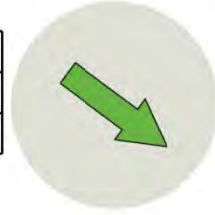

Item No.	Description	Number	Qty
1	3/4" JIC Male Tee 3/4" JIC Male Tee 3/4" JIC Male Tee	0324-519-121212	2

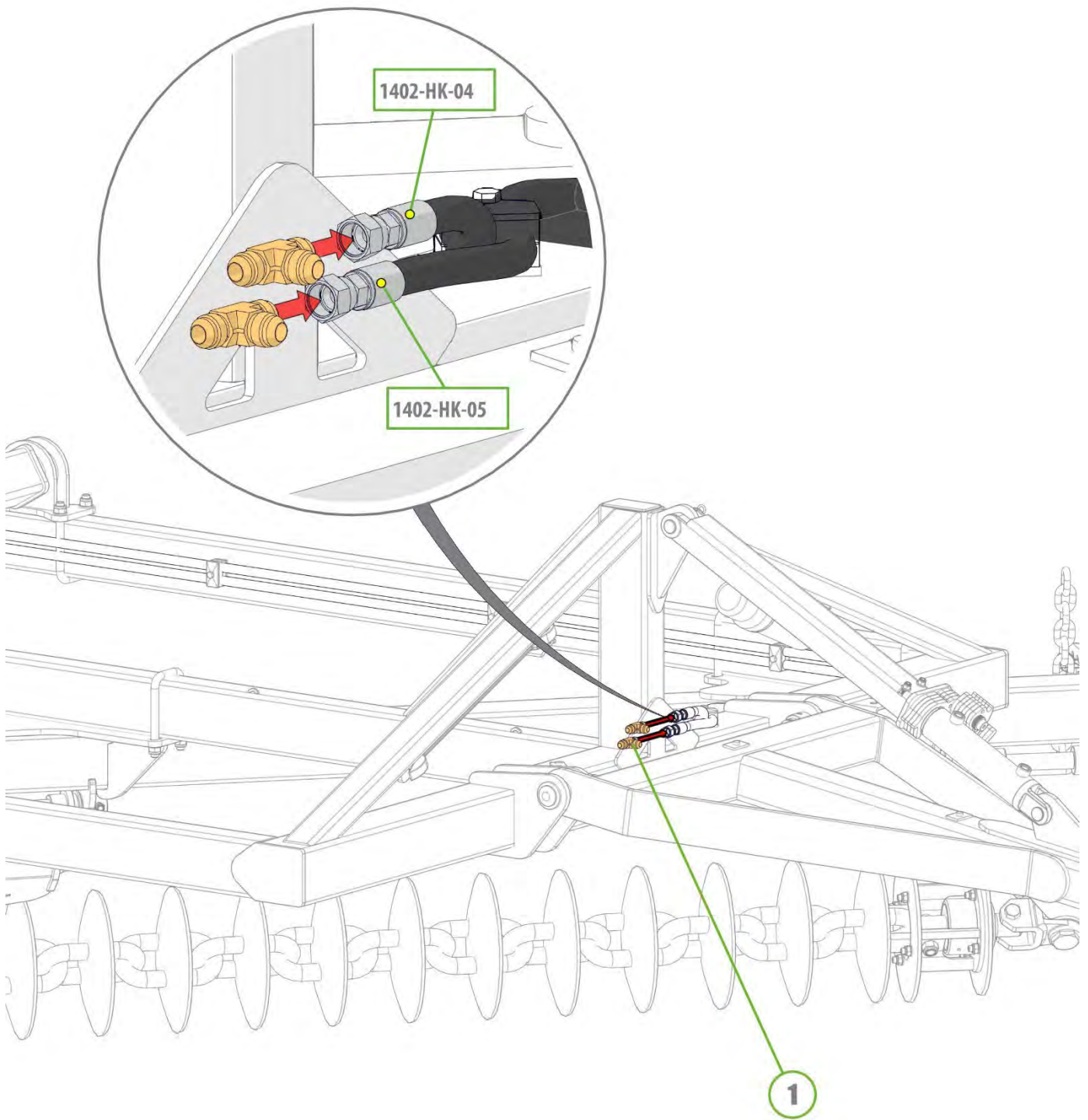

Item No.	Description	Number	Qty
1	3/4" JIC Male 3/4" UN O Ring Male 90° Elbow	0323-S91-1212	2

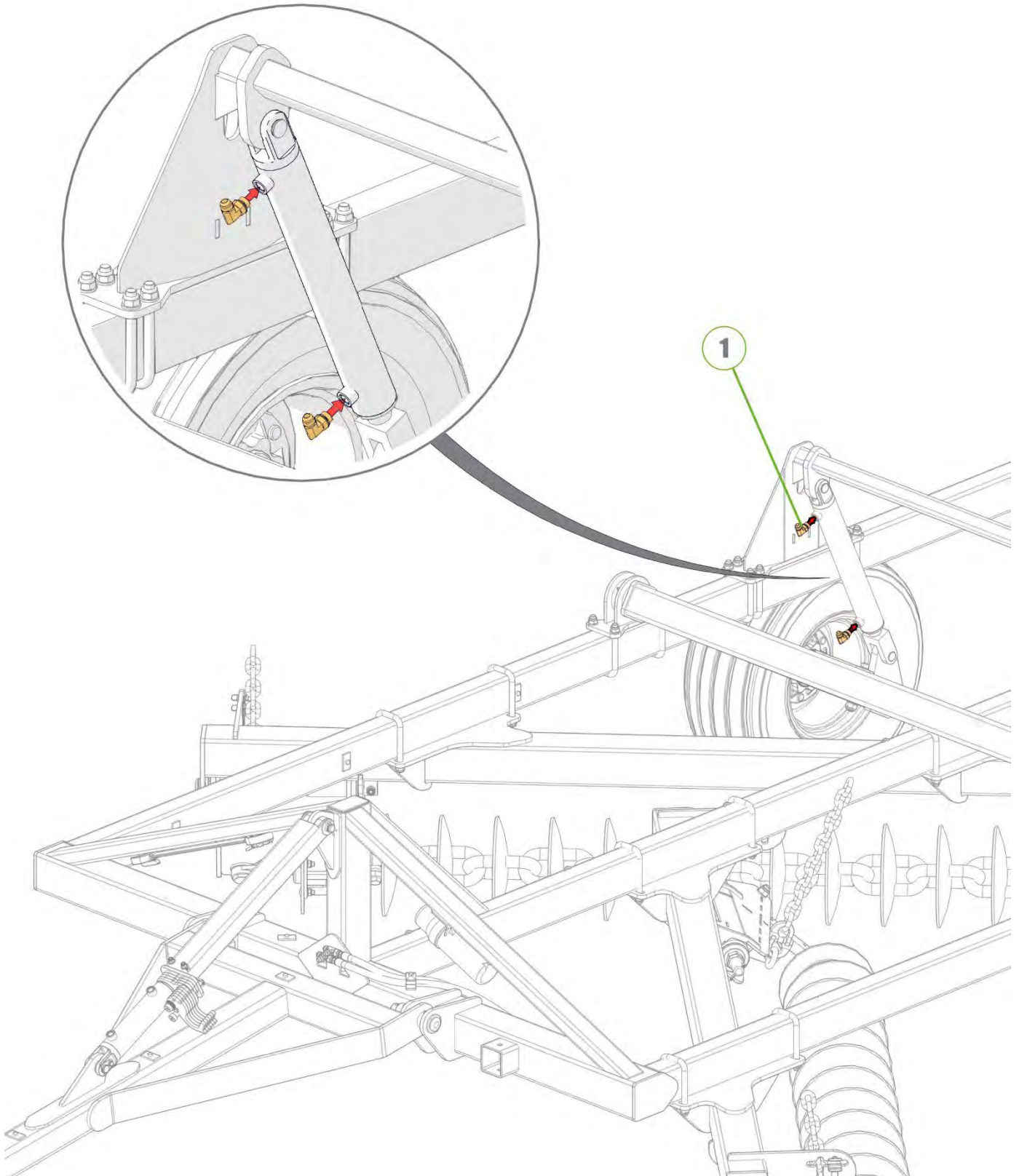

Item No.	Description	Number	Qty
1	Extend Tee To Extend Port of RH Lift Cylinder Hose	1402-HK-06	1
2	Retract Tee To Retract Port of RH Lift Cylinder Hose	1402-HK-07	1

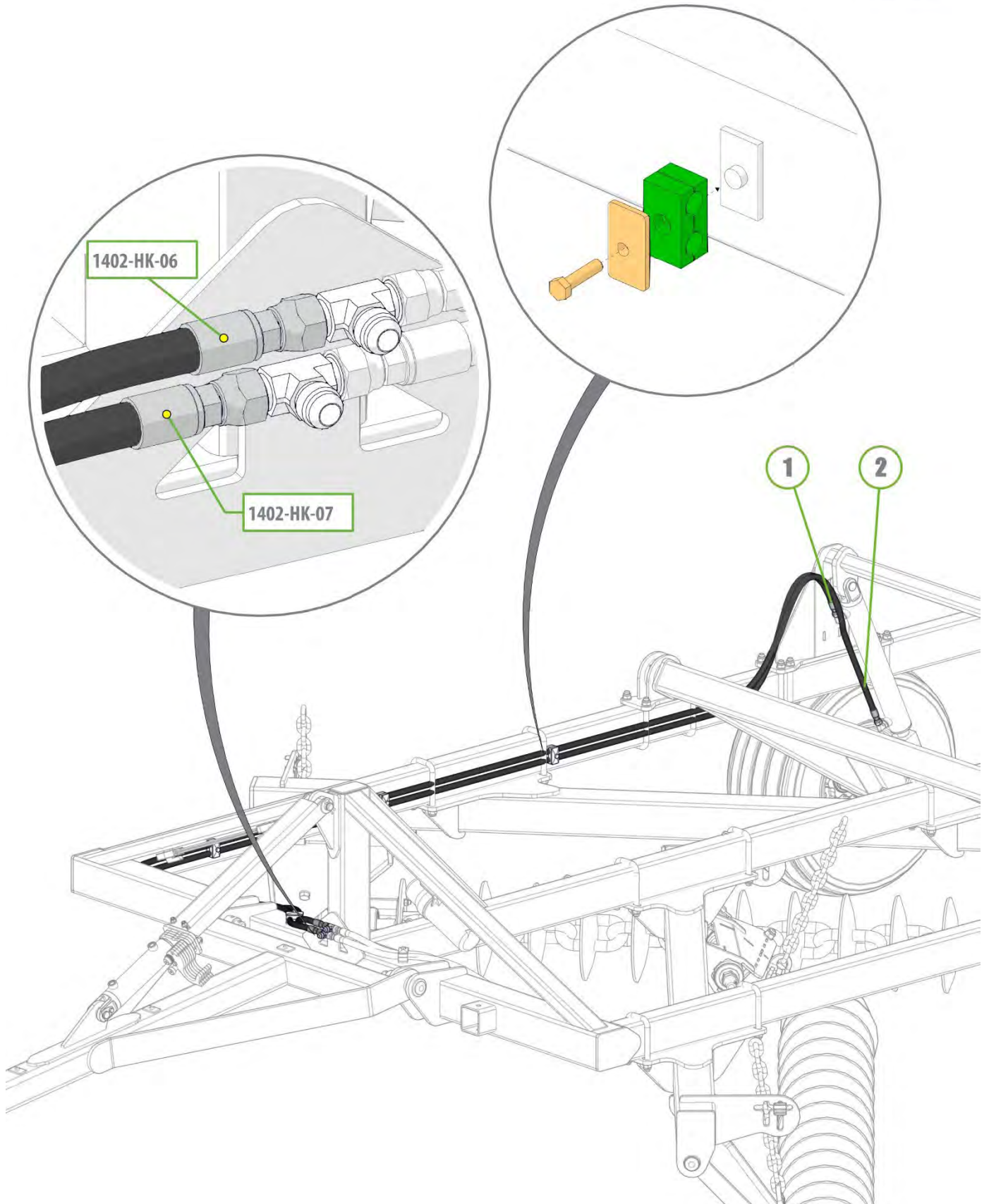

Item No.	Description	Number	Qty
1	3/4" JIC Male to 3/4" JIC Female 3.572mm (9/64") Orifice Adaptor	0323-1212R3.572	2

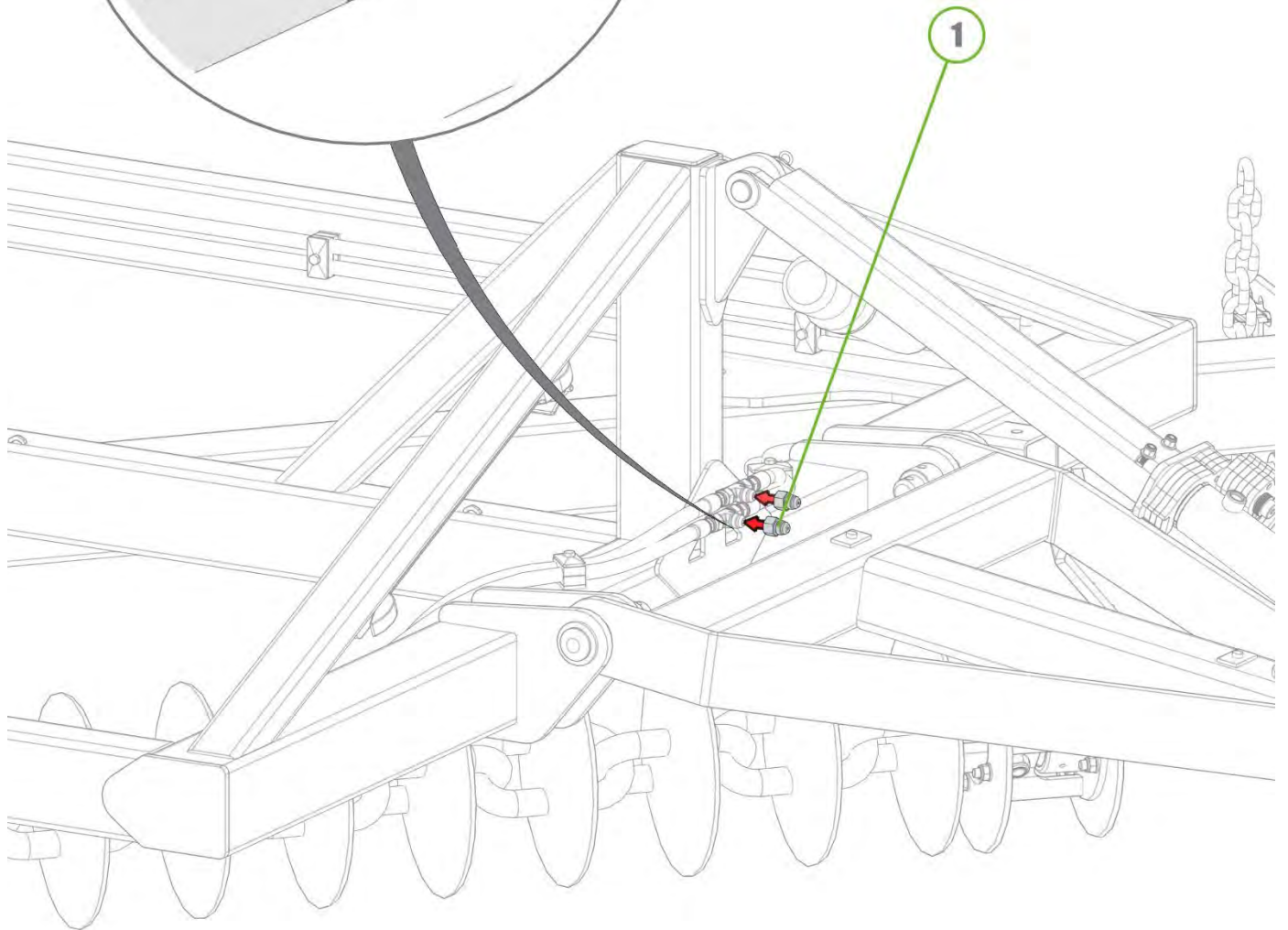
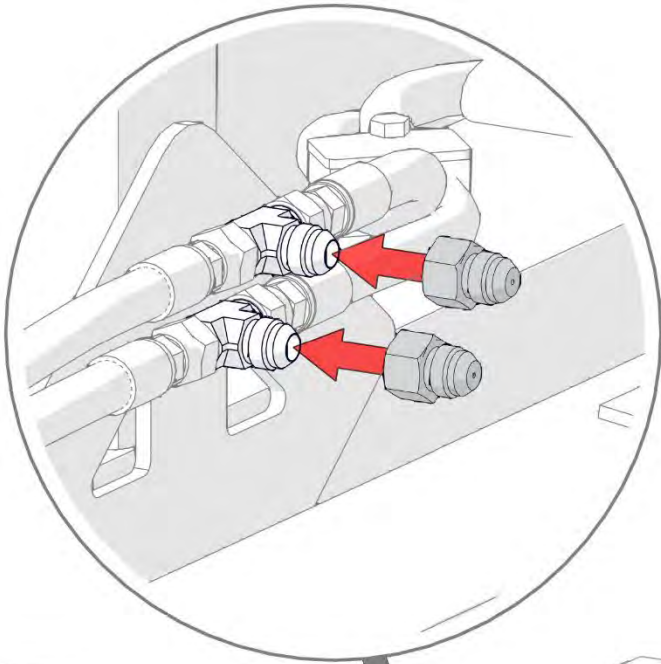

Item No.	Description	Number	Qty
1	Ball Valve to Extend Orifice Fitting	1402-HK-02	1

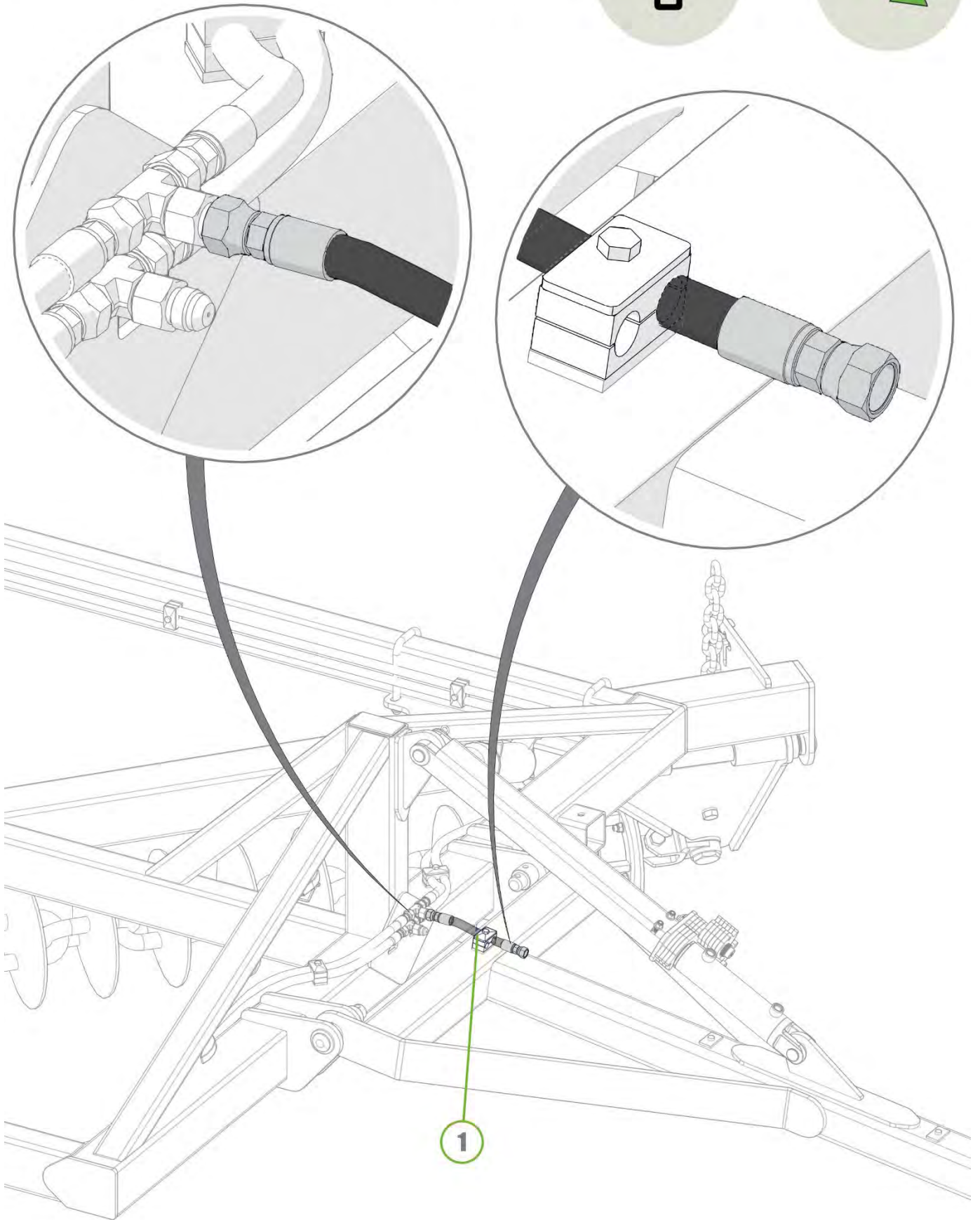

Item No.	Description	Number	Qty
1	1/2" BSPP Encapt Male 3/4" JIC Male Adaptor	0323-S74-0812	1
2	Ball Valve BSPP 1/2"	0341-RL20SH-0808	1

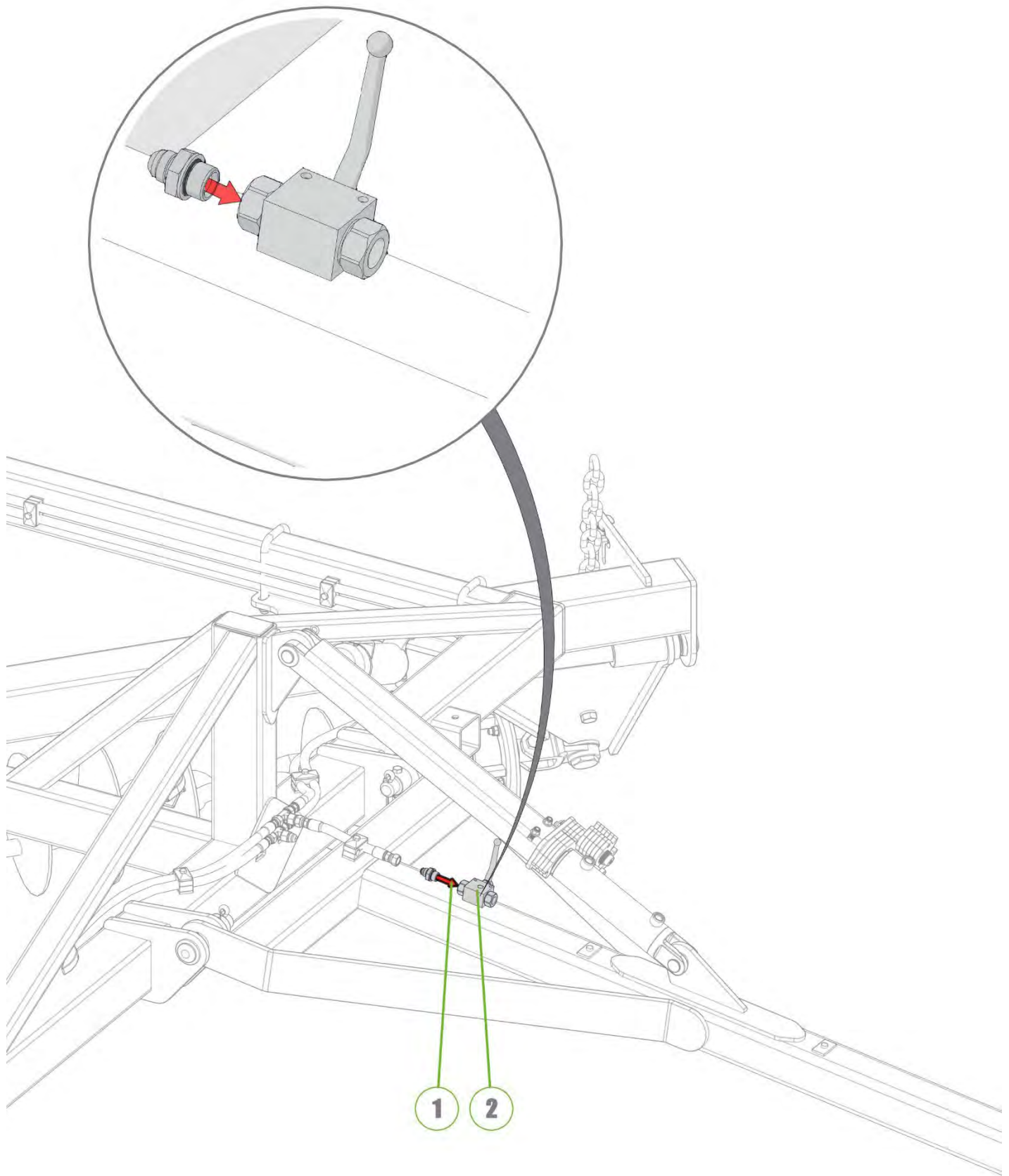

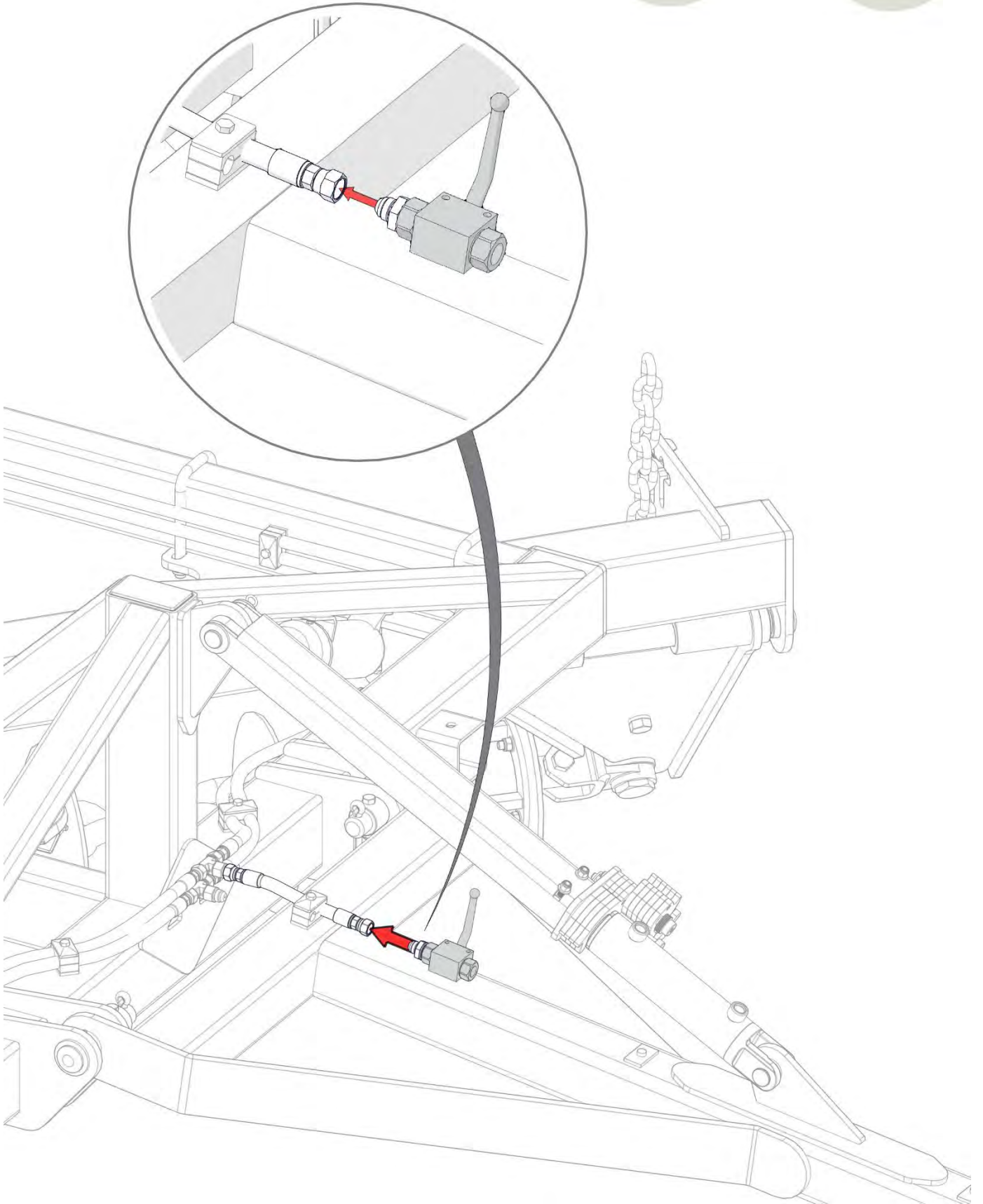

Item No.	Description	Number	Qty
1	1/2" BSPP Encapt Male 3/4" JIC Male Adaptor	0323-S74-0812	1

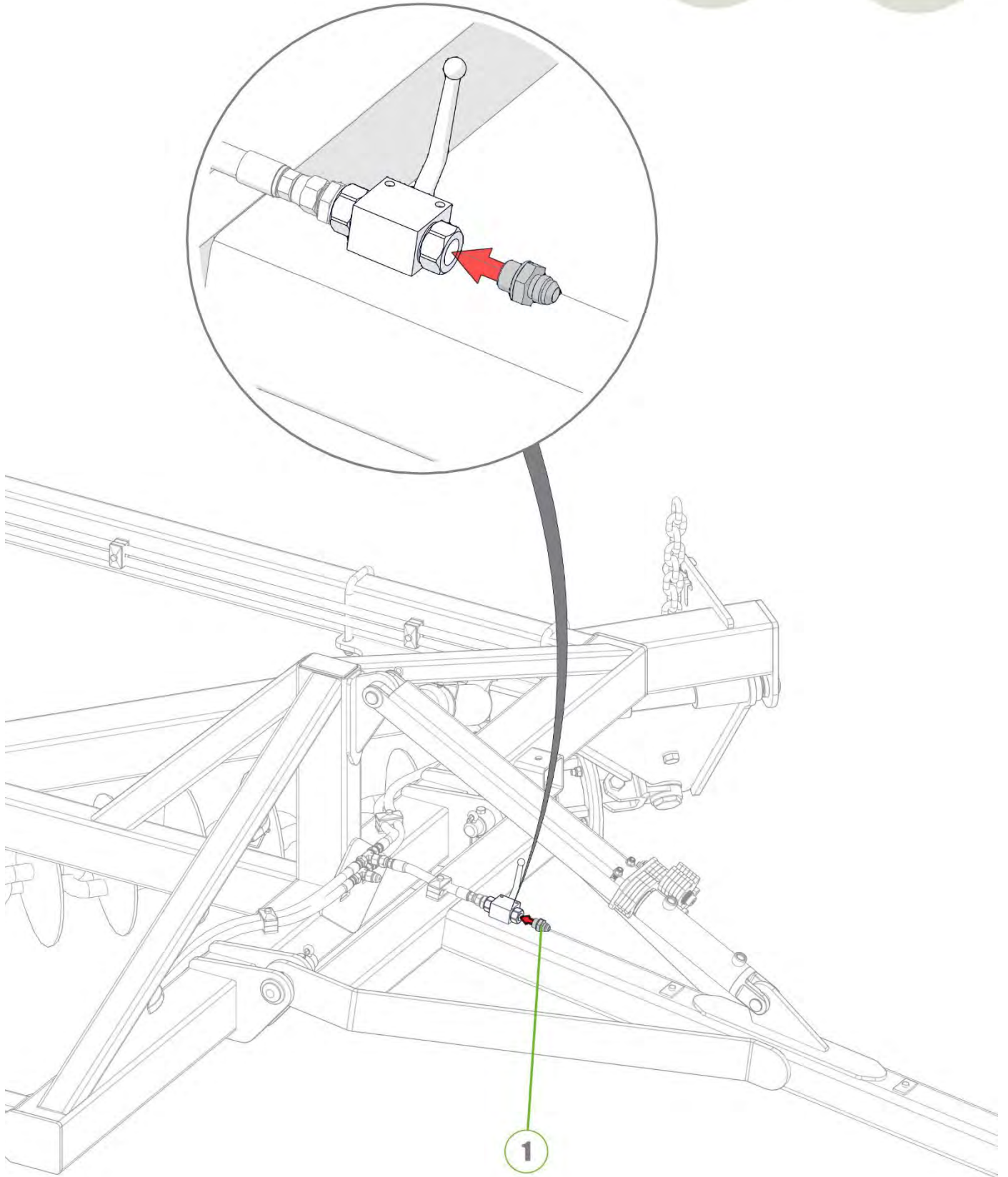

Item No.	Description	Number	Qty
1	3/4" JIC Male 3/4" UN O Ring Male 90° Elbow	0323-S91-1212	2

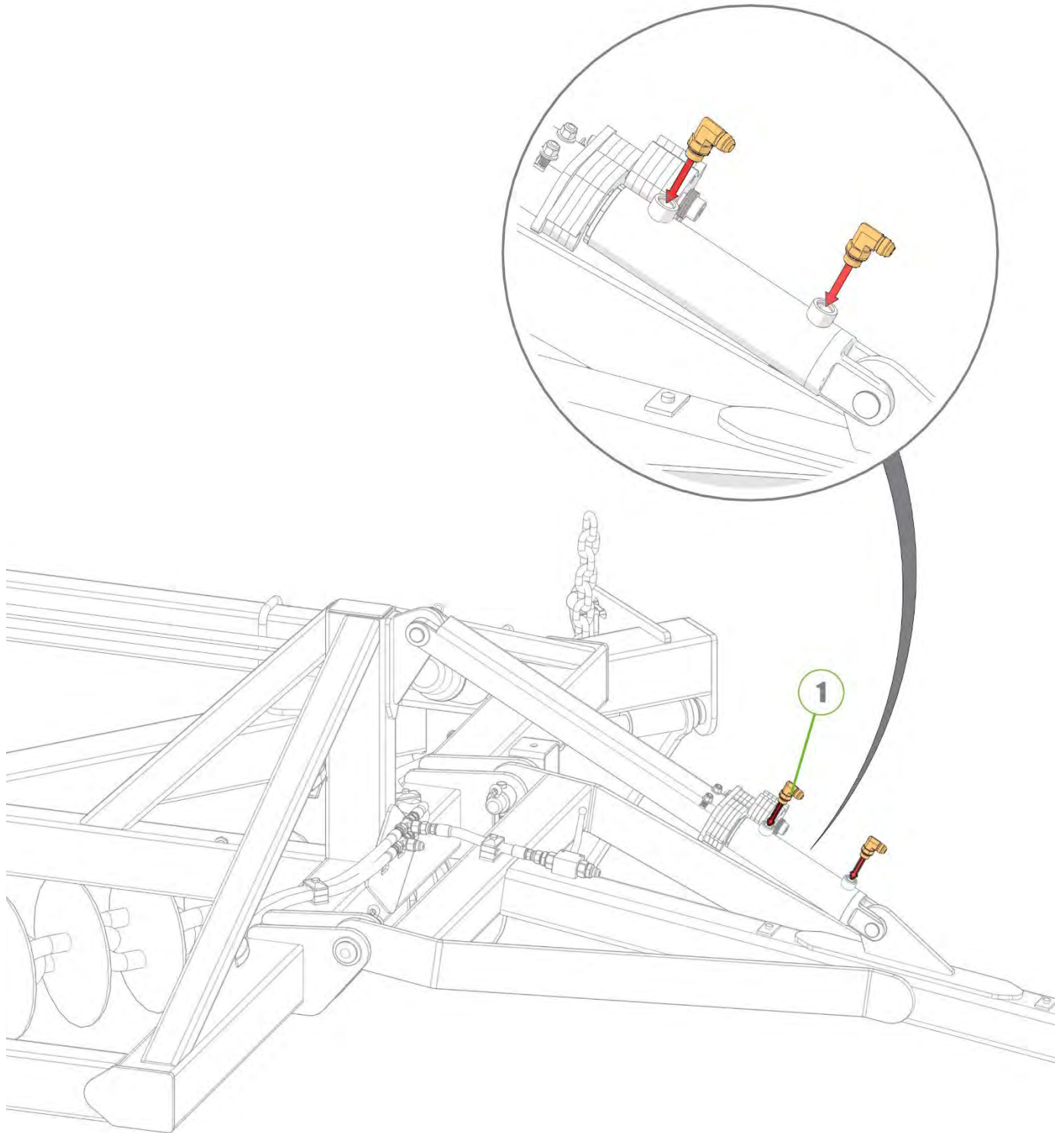

Item No.	Description	Number	Qty
1	3/4" JIC Male to 3/4" JIC Female 1.5875mm (1/16") Orifice Adaptor	0323-1212R1.5875	2

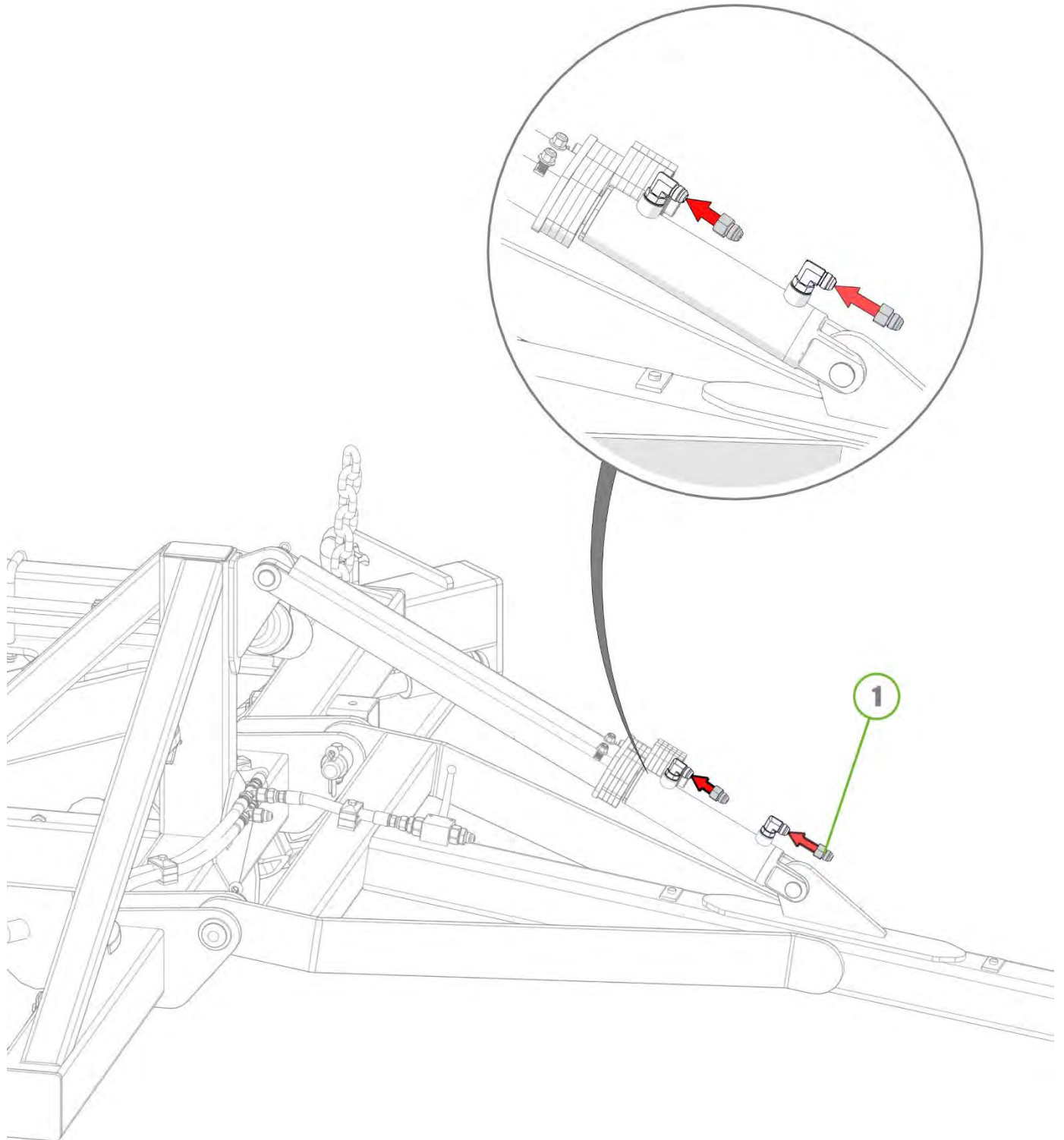

Item No.	Description	Number	Qty
1	3/4" JIC Male 3/4" JIC Female 3/4" JIC Male Tee	0324-S67-121212	2

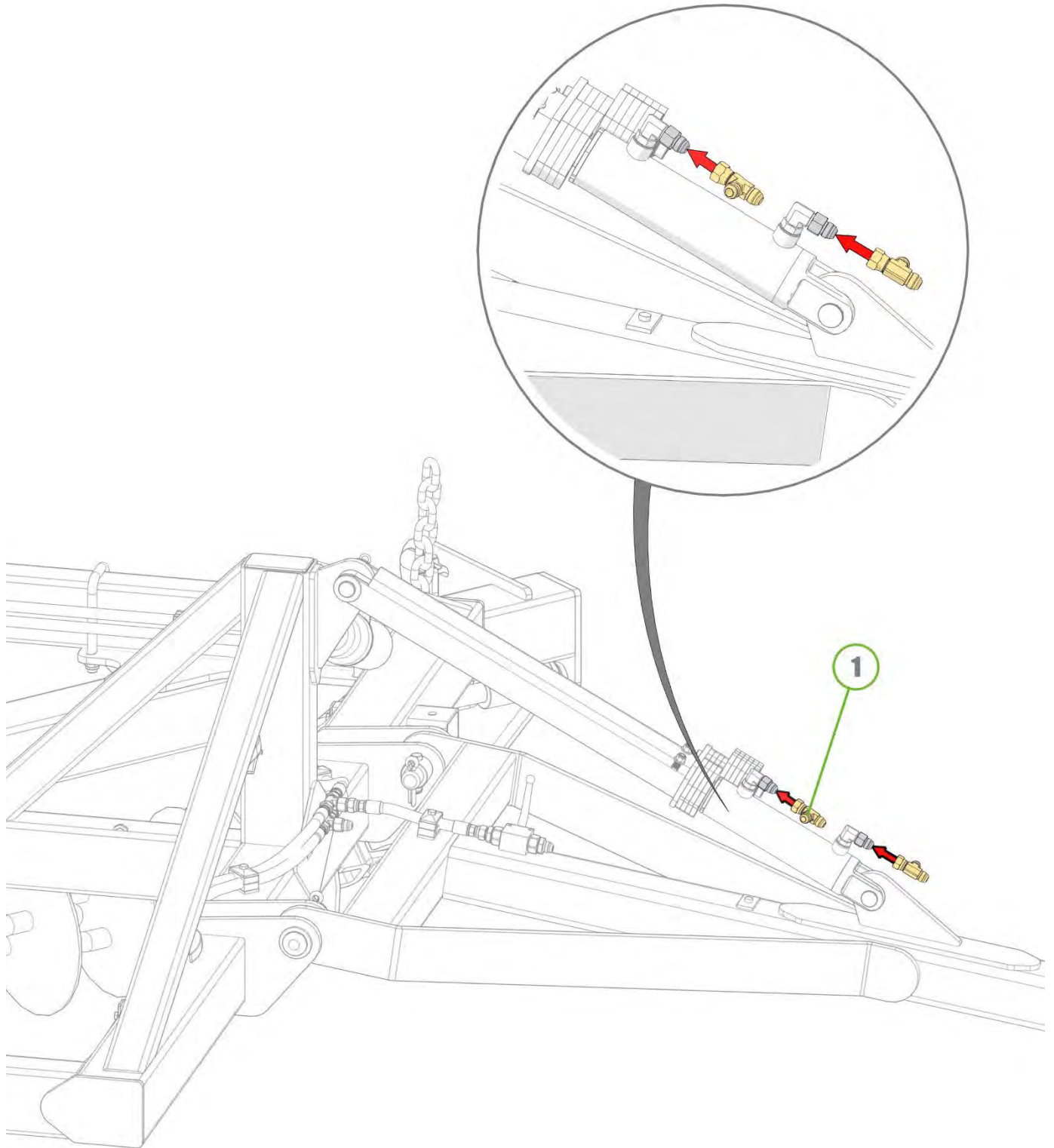

Item No.	Description	Number	Qty
1	Front Cylinder Extend Tee To Ball Valve	1402-HK-10	1
2	Retract Orifice Fitting To Front Cylinder Retract Tee	1402-HK-11	1

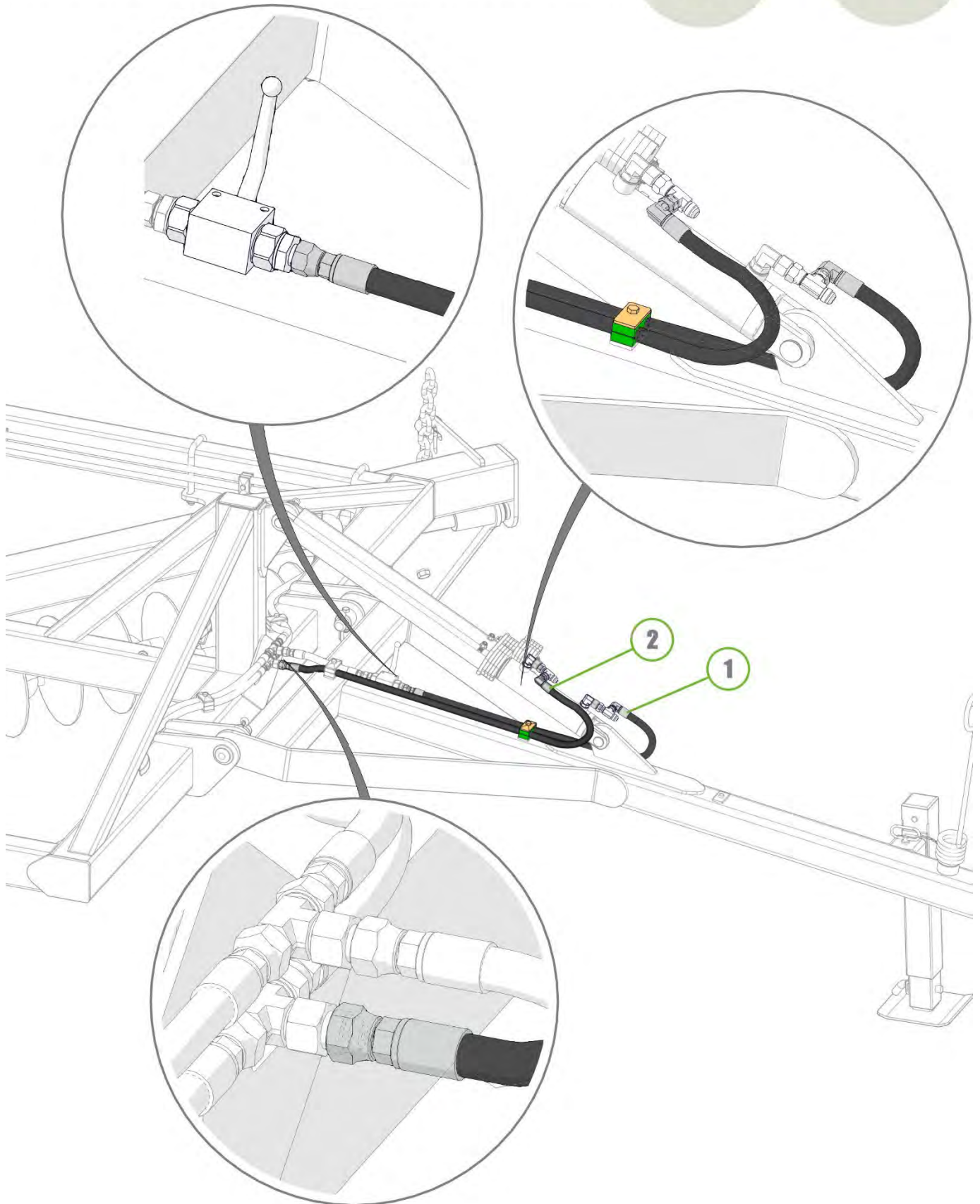

Item No.	Description	Number	Qty
1	Tractor To Extend Port Of Front Cylinder Fitted with Blue Extend Grip Hose	1402-HK-09	1
2	Tractor To Retract Port Of Front Cylinder Fitted with Blue Retract Grip Hose	1402-HK-08	1

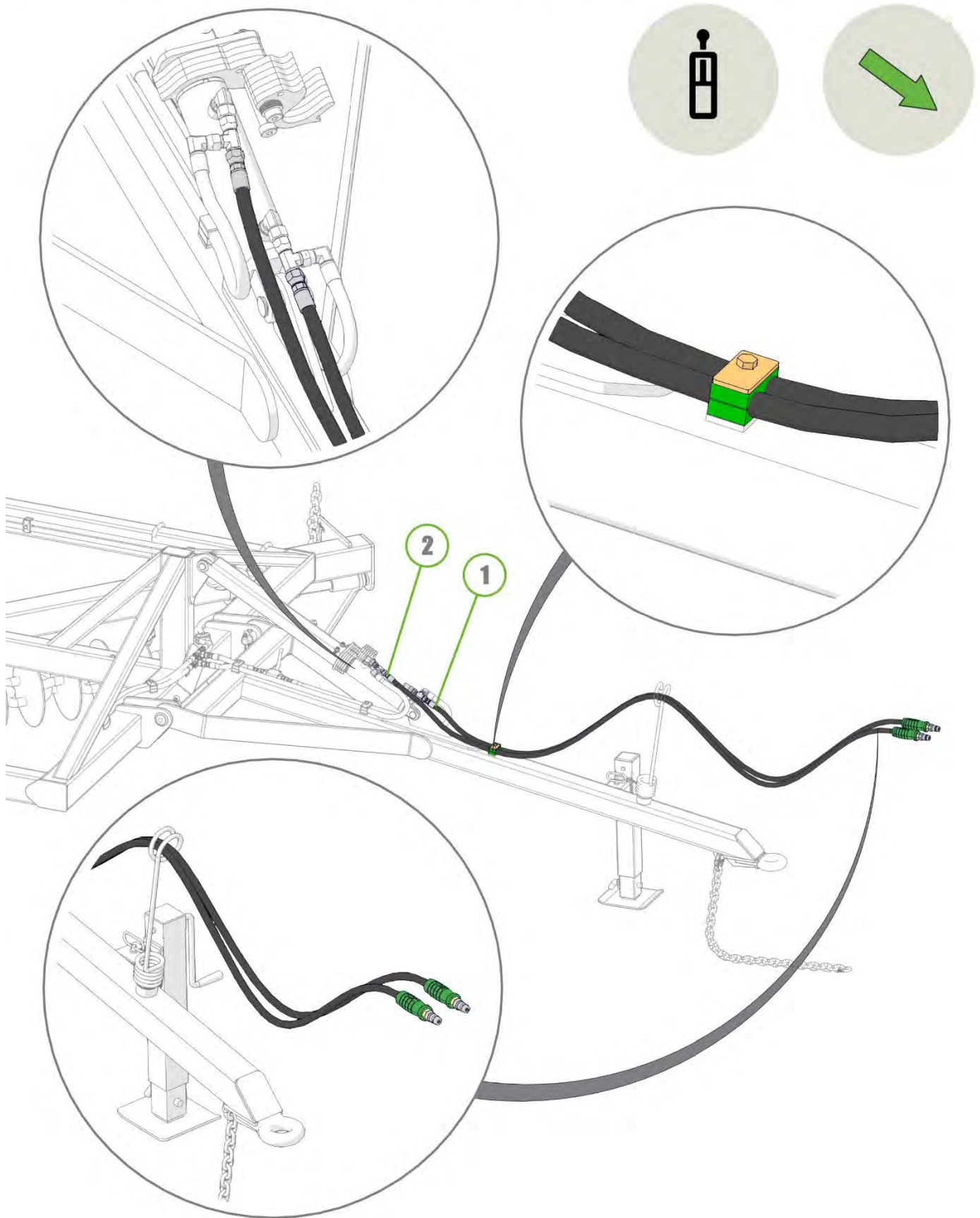



SECTION 4
DECAL APPLICATION

SECTION 4 DECAL APPLICATION

Item No.	Description	Number	Qty
1	Red Reflective Decal	0801-SRRF	2

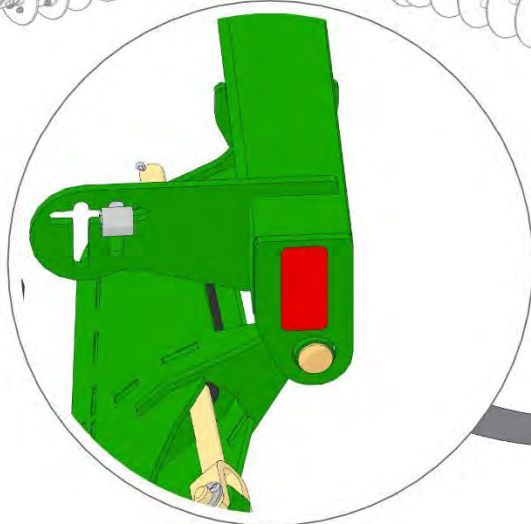
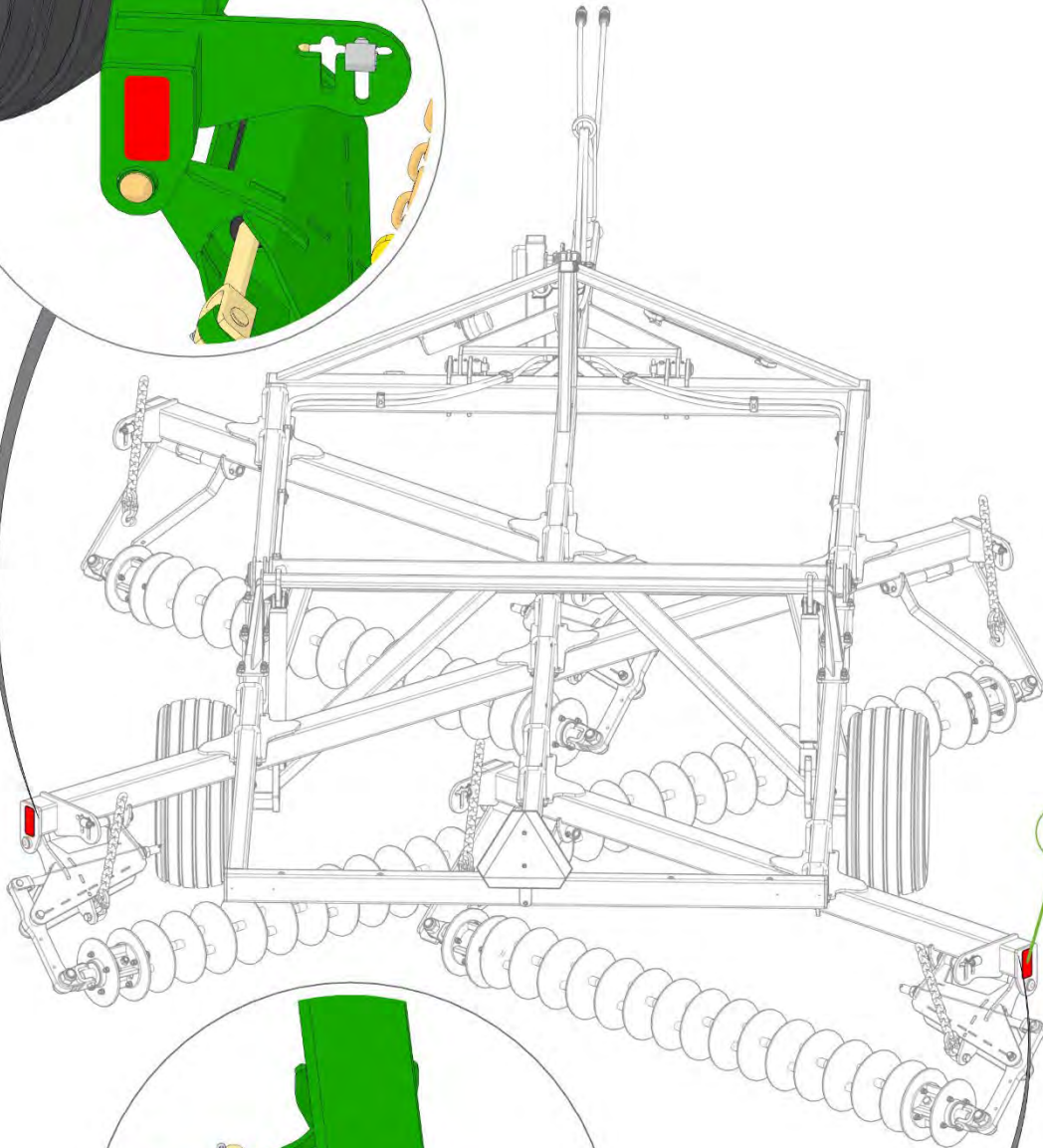
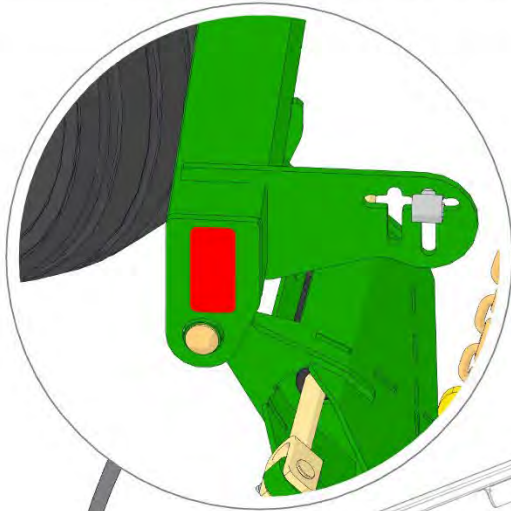

Item No.	Description	Number	Qty
1	Chain Tension 330mm Decal	0801-515	1
2	Danger Crush Hazard Decal	0801-53	1
3	Decal- 31/13.5/15 Tyre Inflation	0801-58-31-13.5-15	1
4	Pinch Point Decal	0801-517	1
5	Wheel Nut Decal	0801-59	1

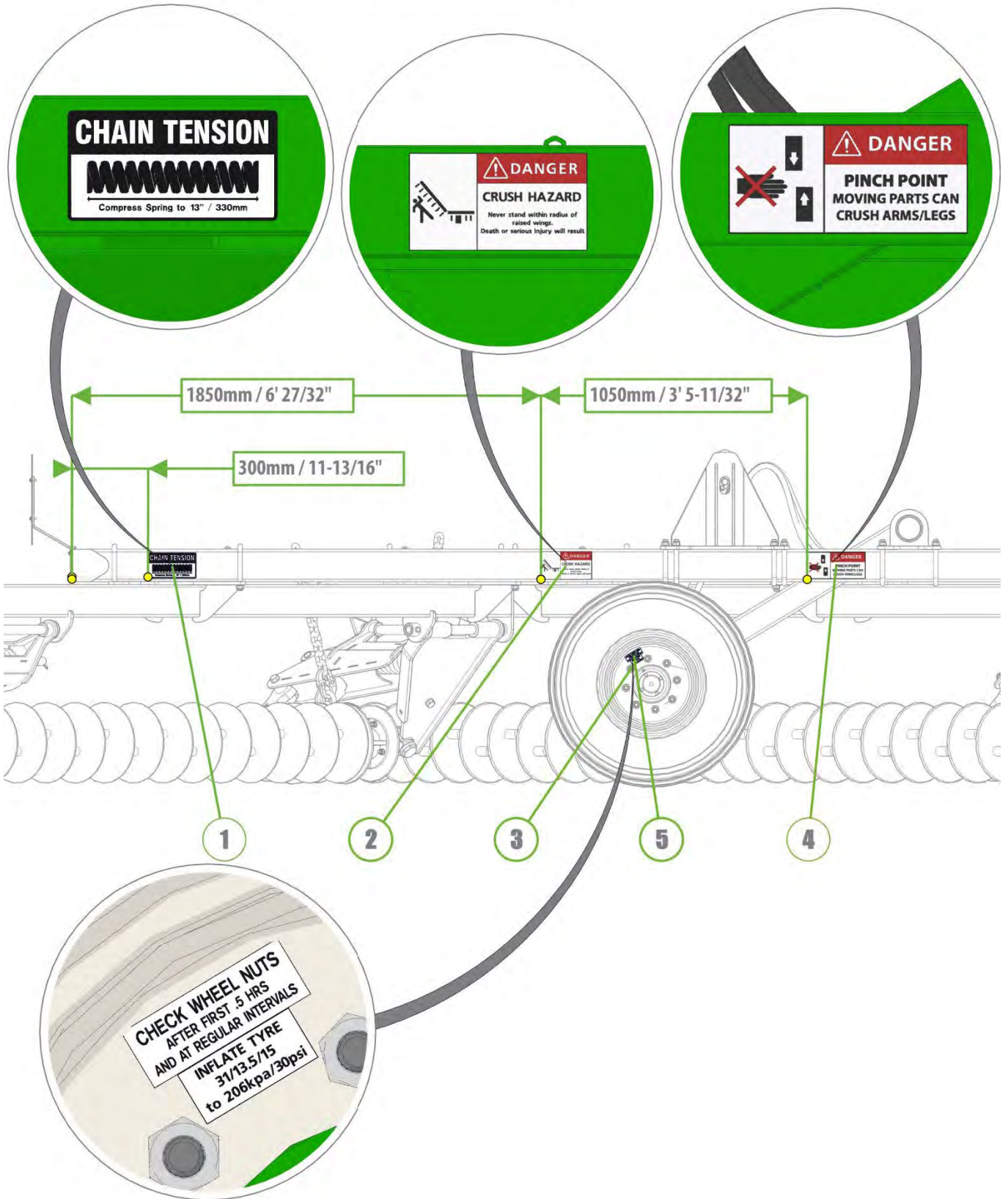

Item No.	Description	Number	Qty
1	Grease Decal	0801-S10	2

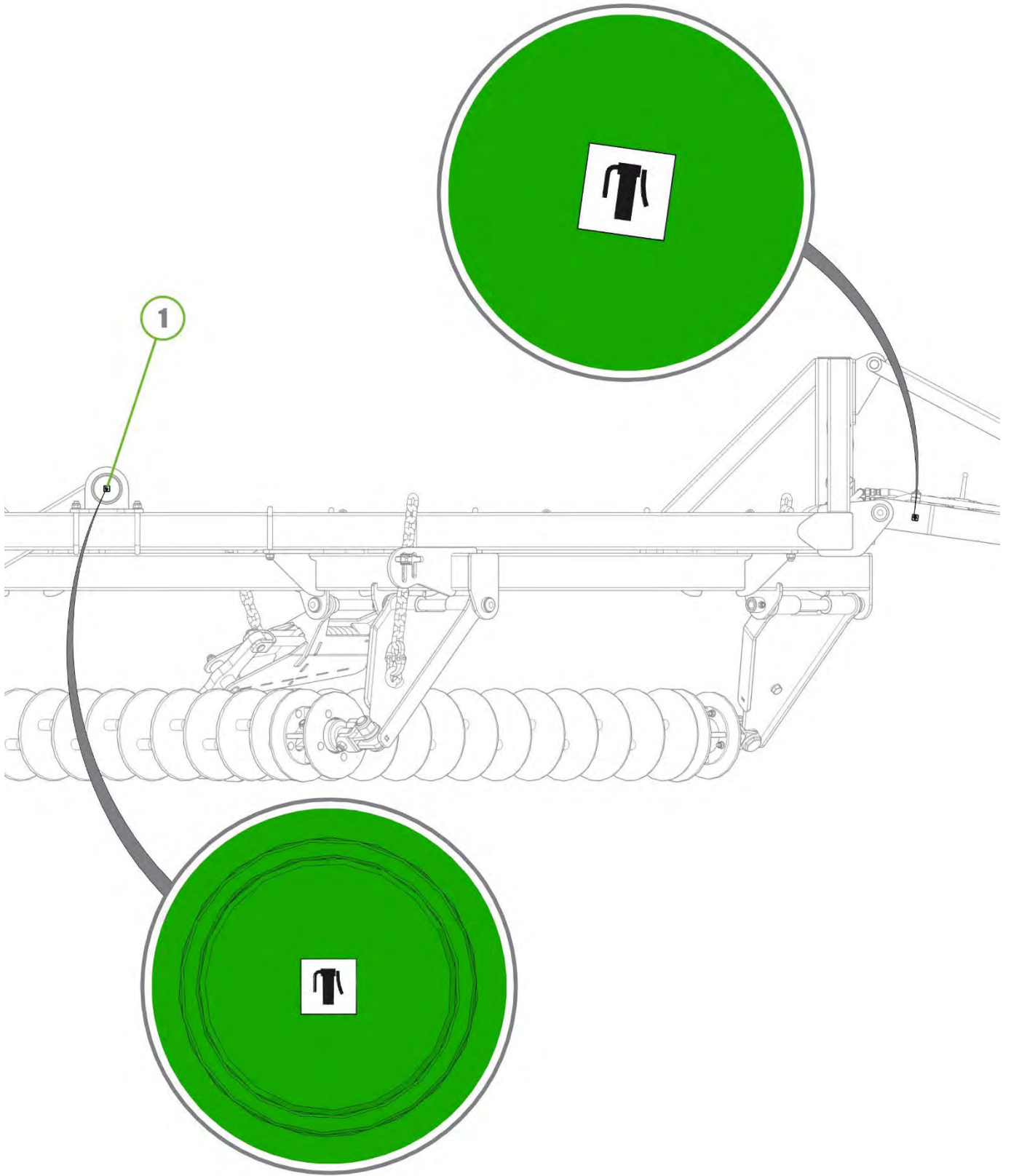

Item No.	Description	Number	Qty
1	Diamond Harrow 12X Decal	0801-SKDH12X	1
2	Kelly Engineering Decal	0801-S12	1

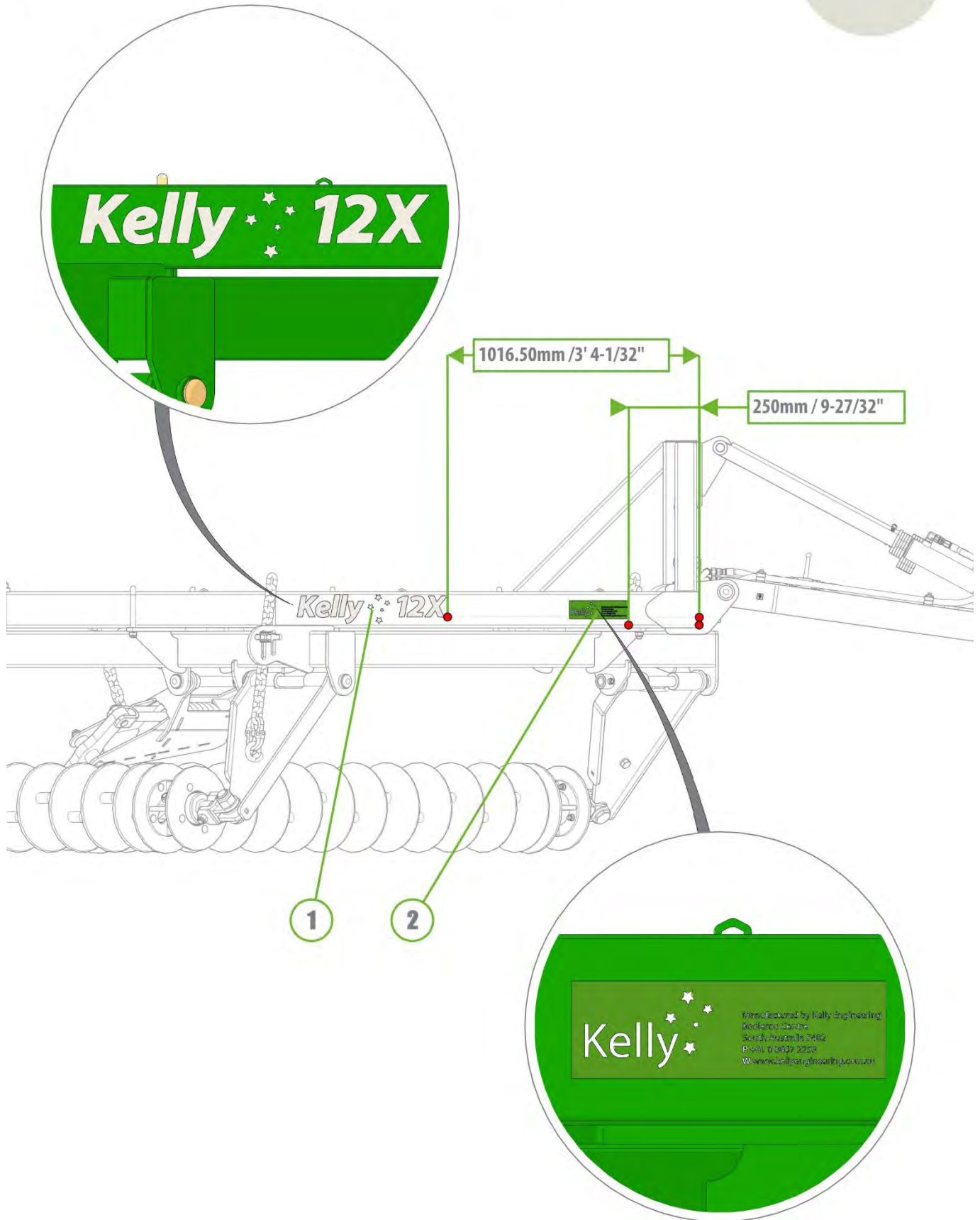

Item No.	Description	Number	Qty
1	Hydraulic Pressure Caution Decal	0801-S4	1
2	Towing Speed Decal	0801-S5	1

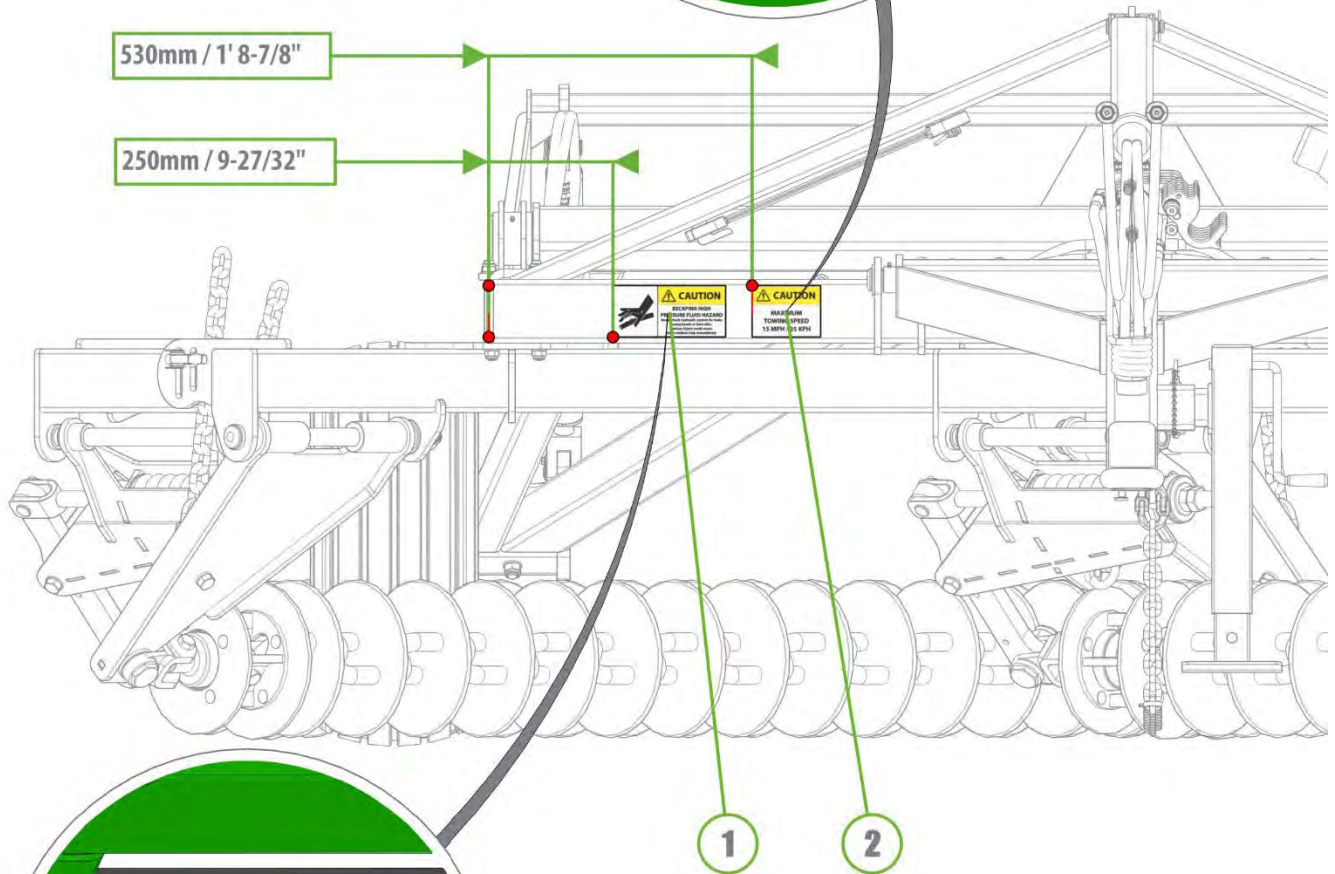

Item No.	Description	Number	Qty
1	Yellow Reflective Decal	0801-SYRF	2

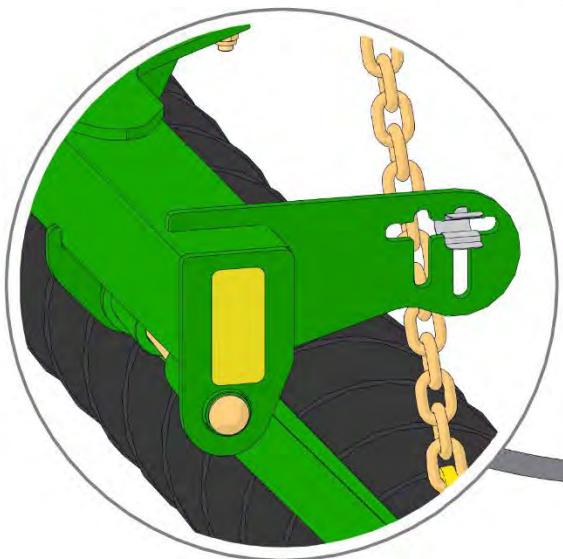
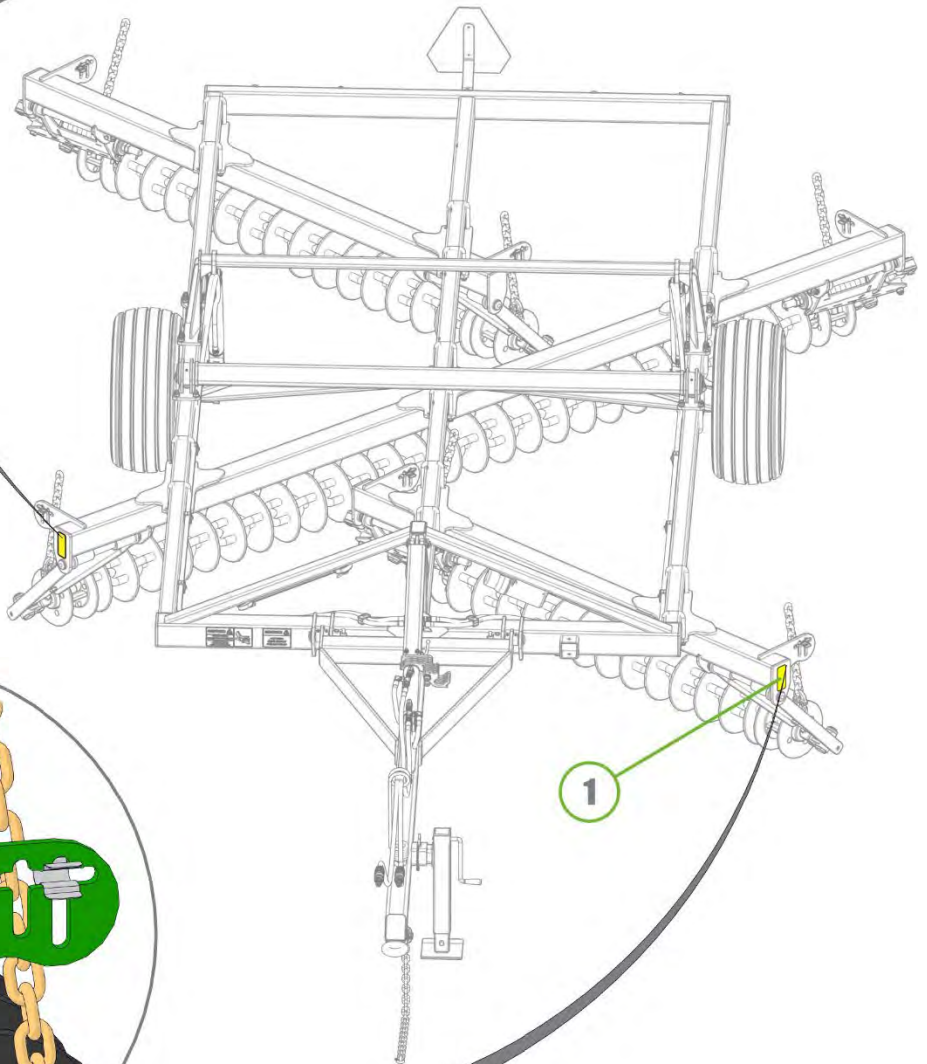
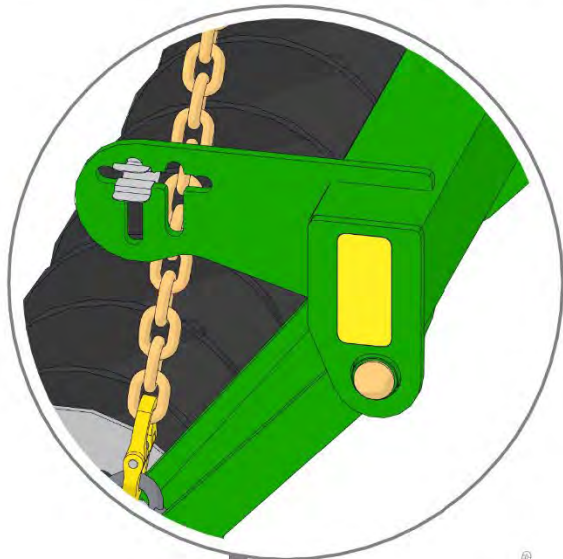

Item No.	Description	Number	Qty
1	Grease Decal	0801-S10	2

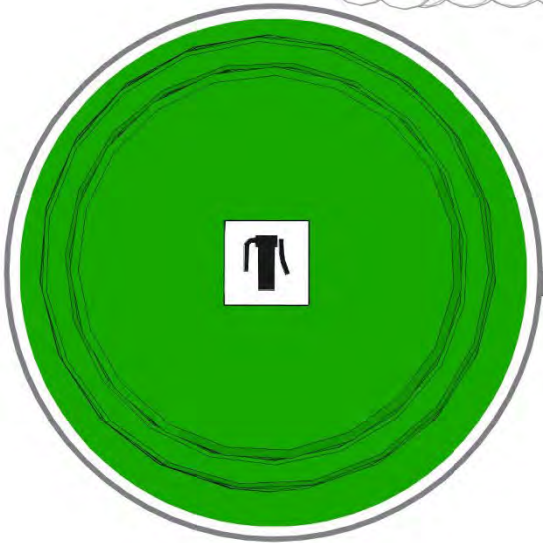
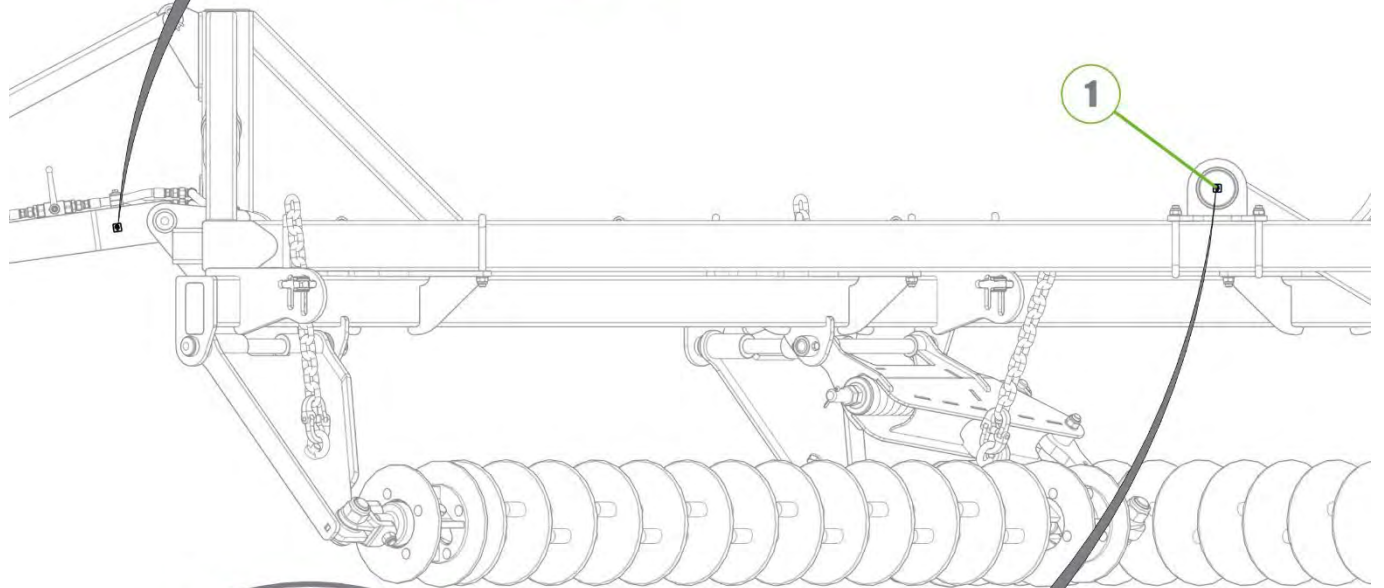
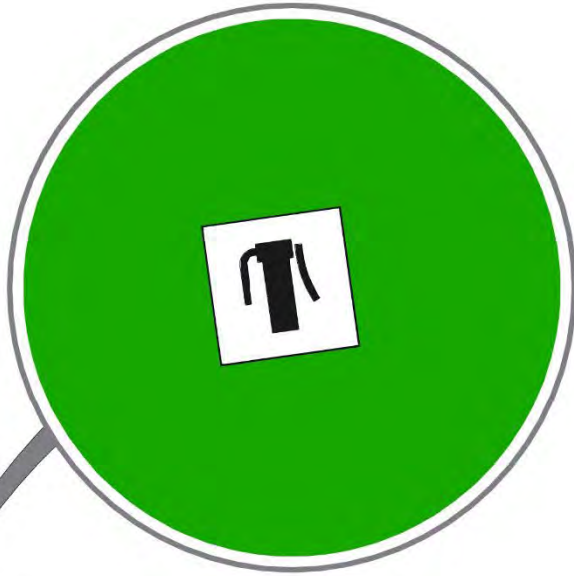

Item No.	Description	Number	Qty
1	Diamond Harrow 12X Decal	0801-SKDH12X	1
2	Kelly Engineering Decal	0801-S12	1

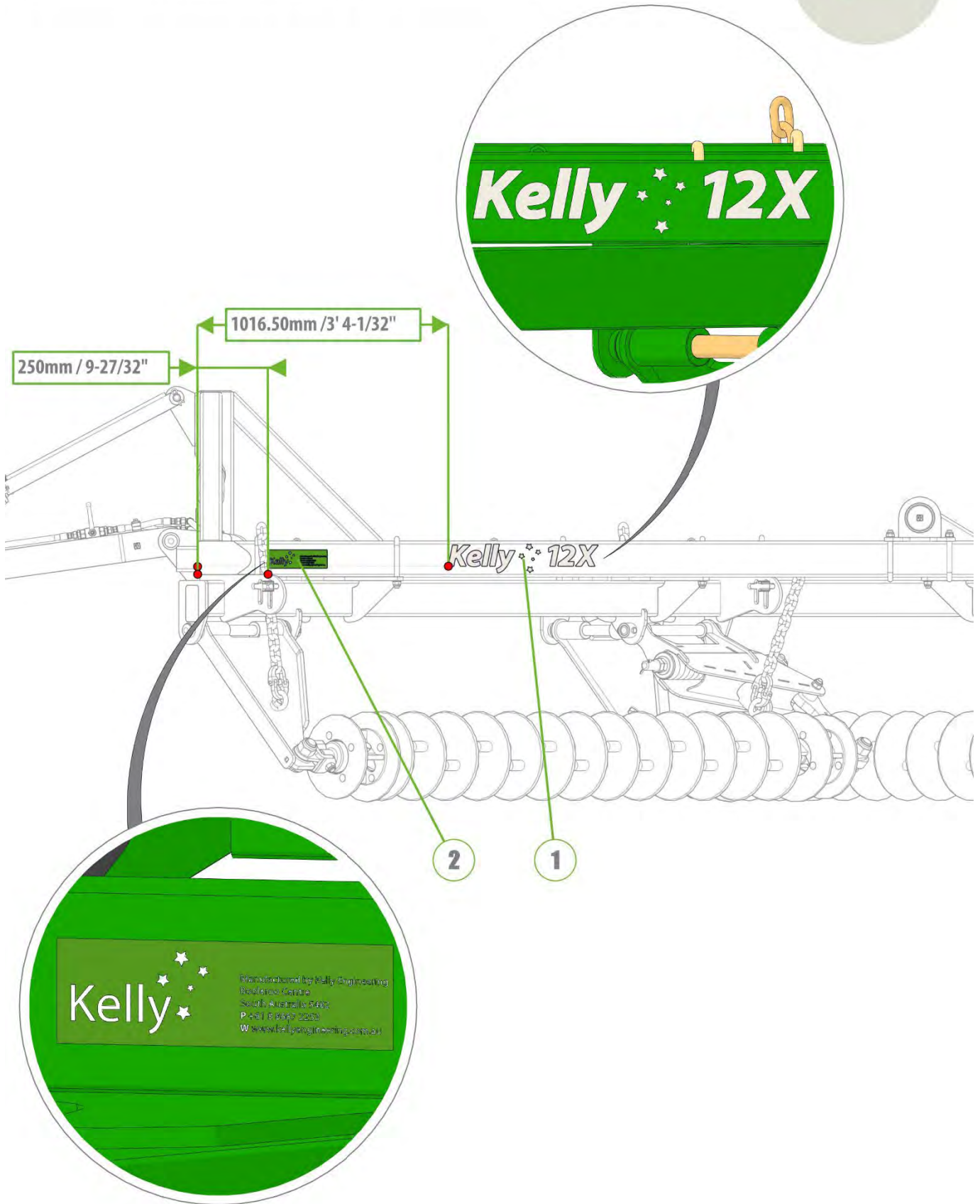

Item No.	Description	Number	Qty
1	Chain Tension 330mm Decal	0801-S15	1
2	Danger Crush Hazard Decal	0801-S3	1
3	Decal- 31/13.5/15 Tyre Inflation	0801-S8-31-13.5-15	1
4	Pinch Point Decal	0801-S17	1
5	Wheel Nut Decal	0801-S9	1

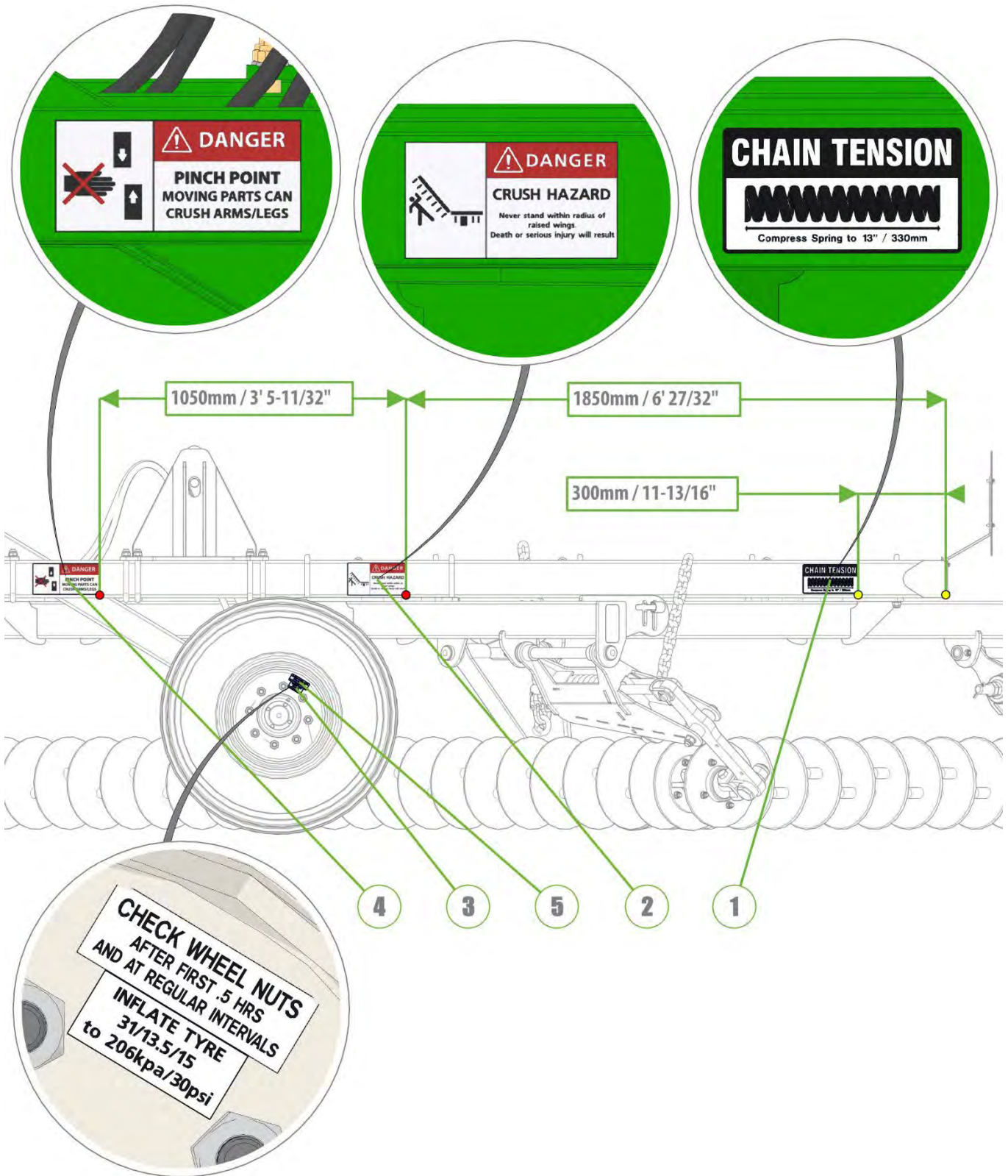



SECTION 5
LIGHT KIT

SECTION 5 LIGHT KIT

Item No.	Description	Number	Qty
1	US Tail Light Bracket	0800-194.1	2
2	LED Stop Tail Lamp	0412-LED110RM	2
3	110RM Rubber Grommet	0412-53101RG	2
4	M6 x 20mm Trilobe Screw	0211-M620MZPHTF	4



1410-01-2A-AS1

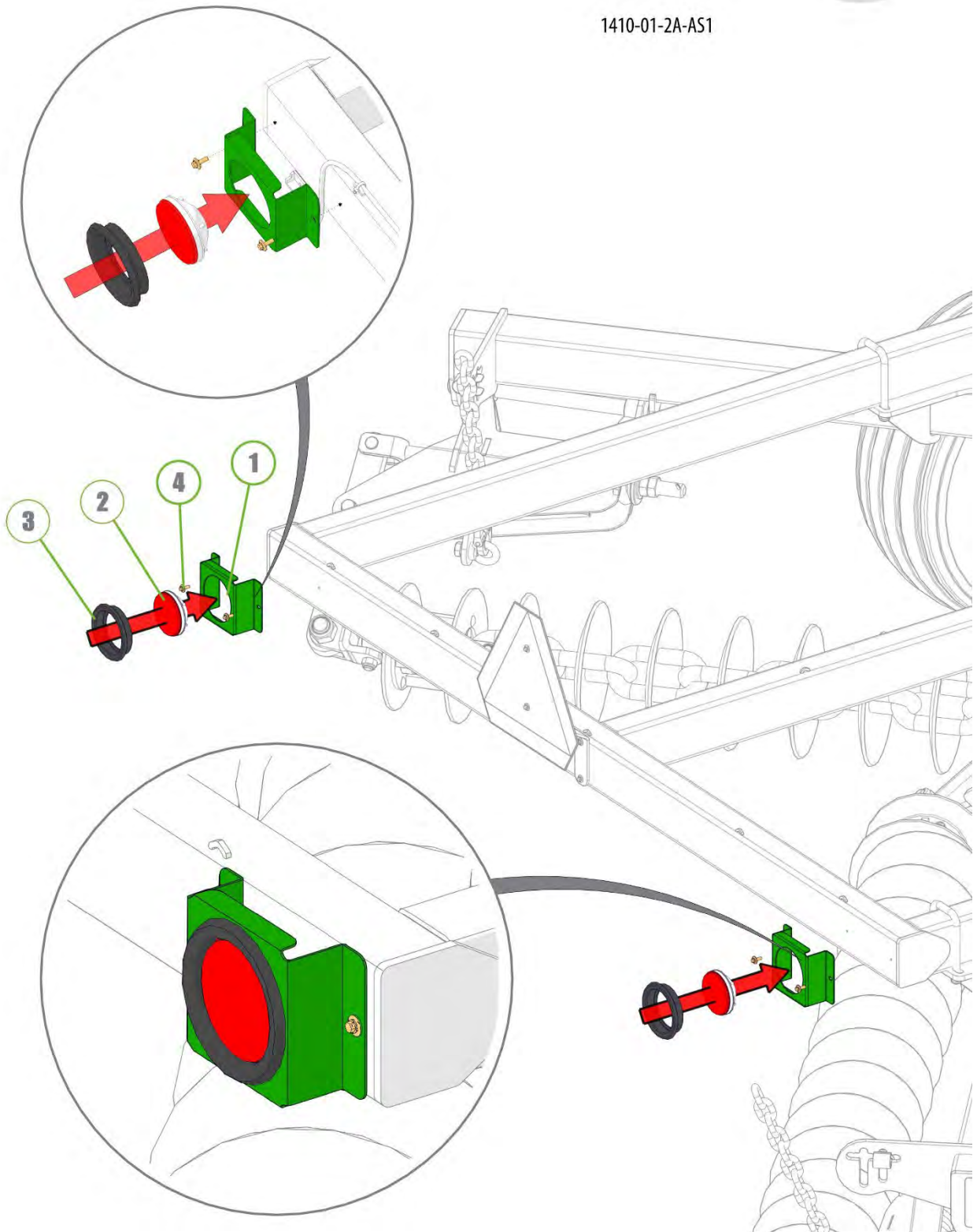

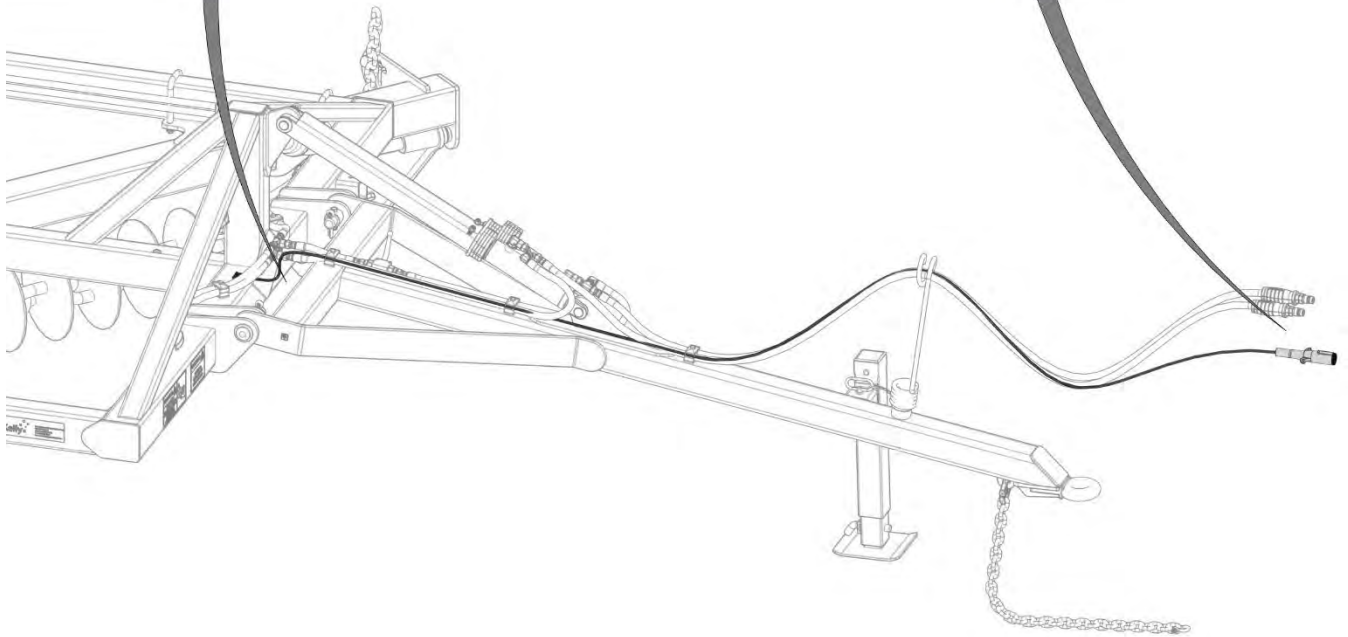
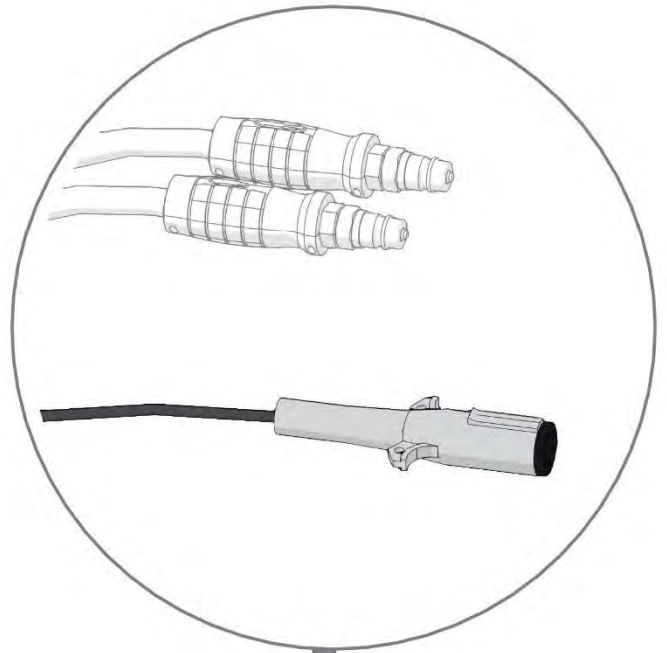
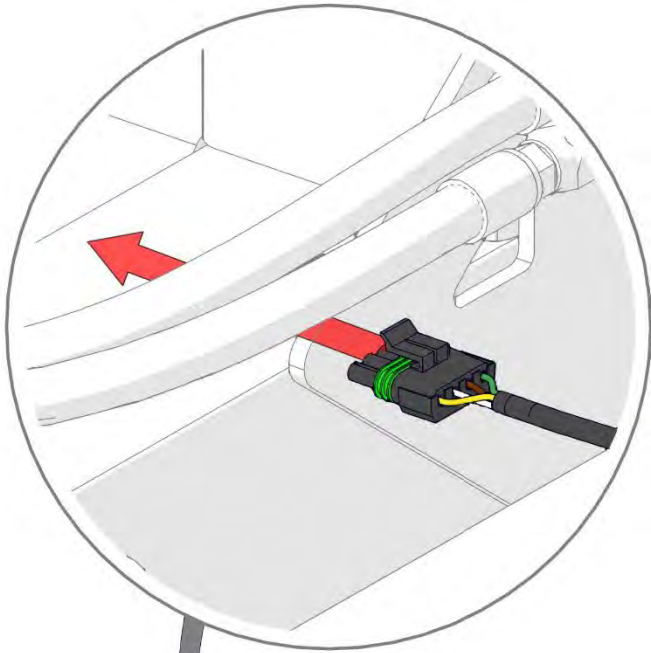

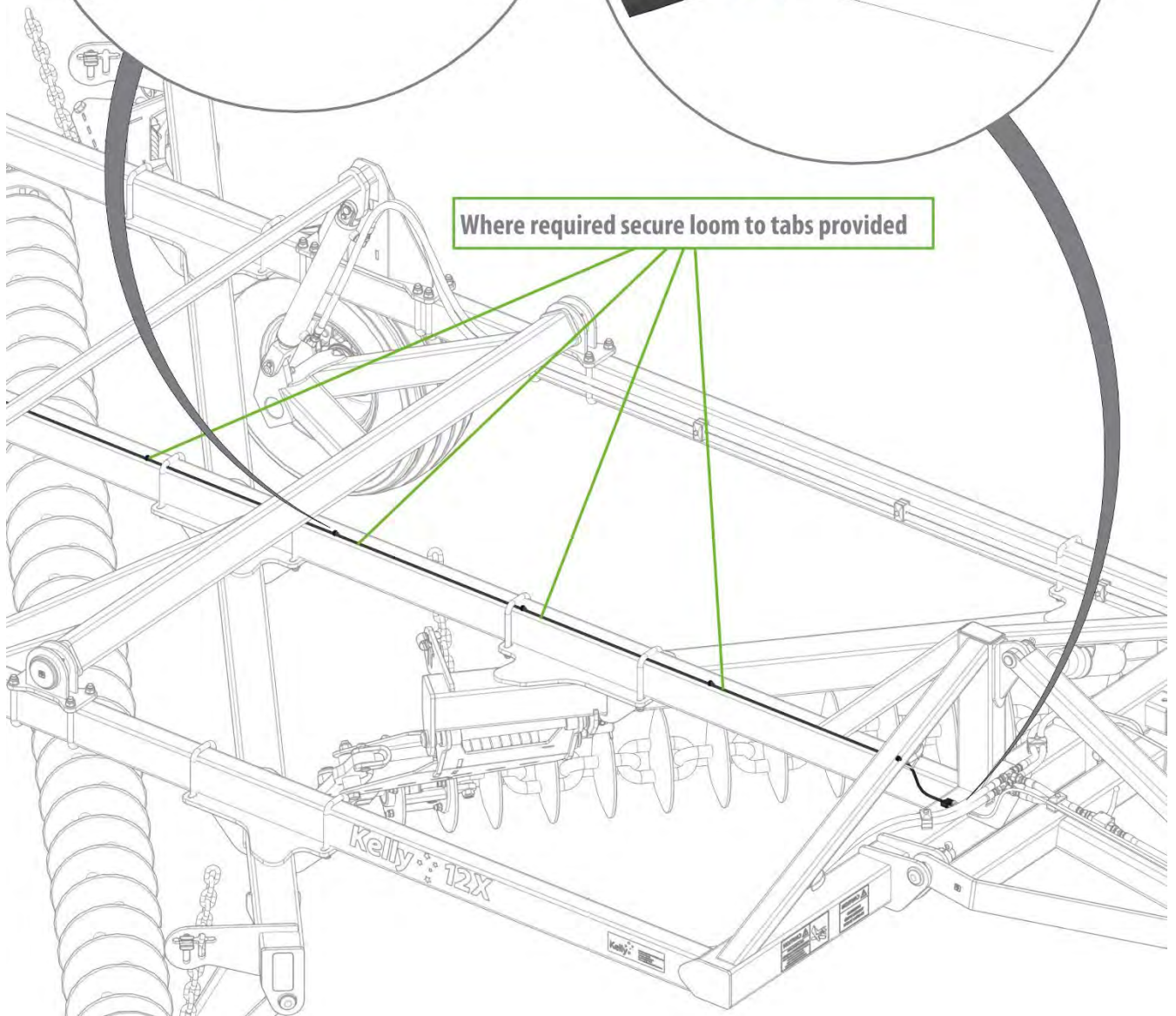
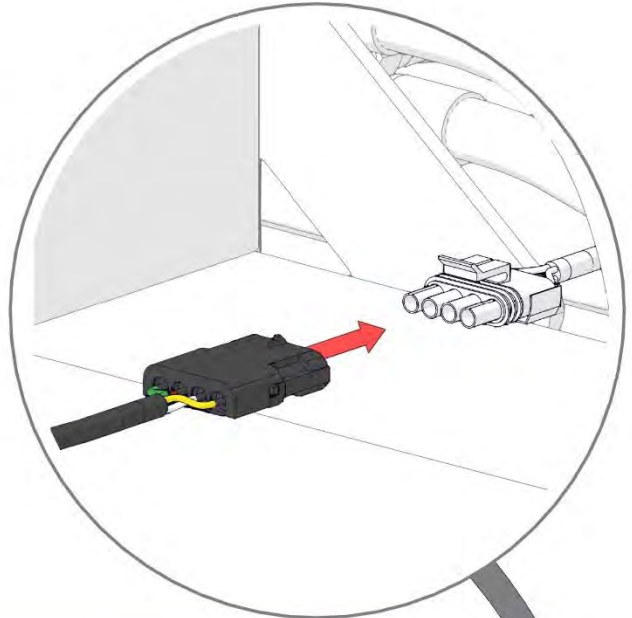
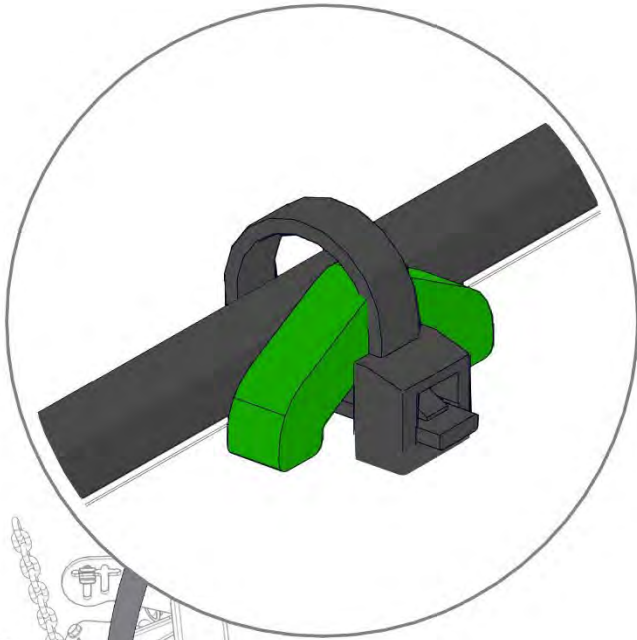

Where required secure loom to tabs provided

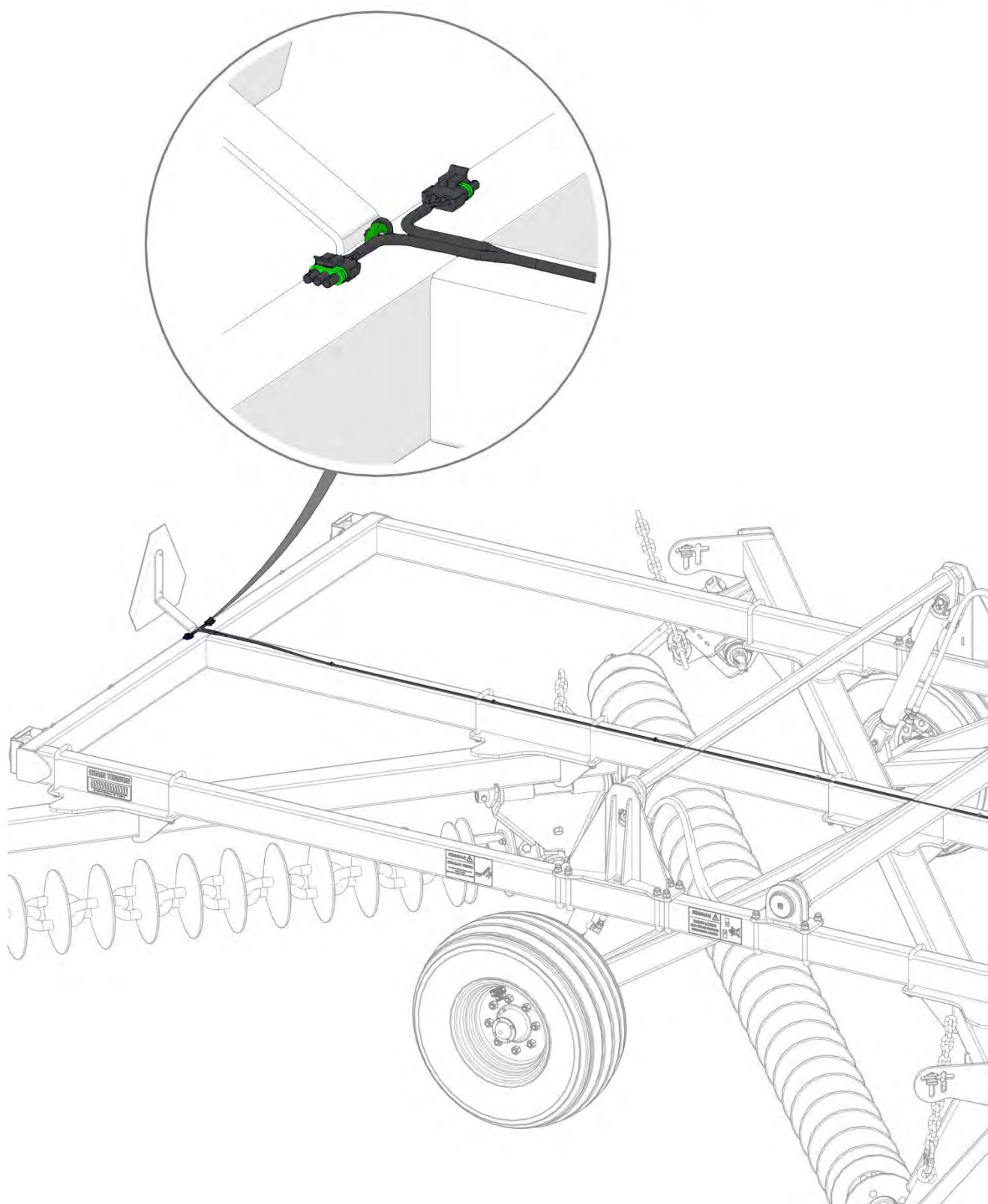

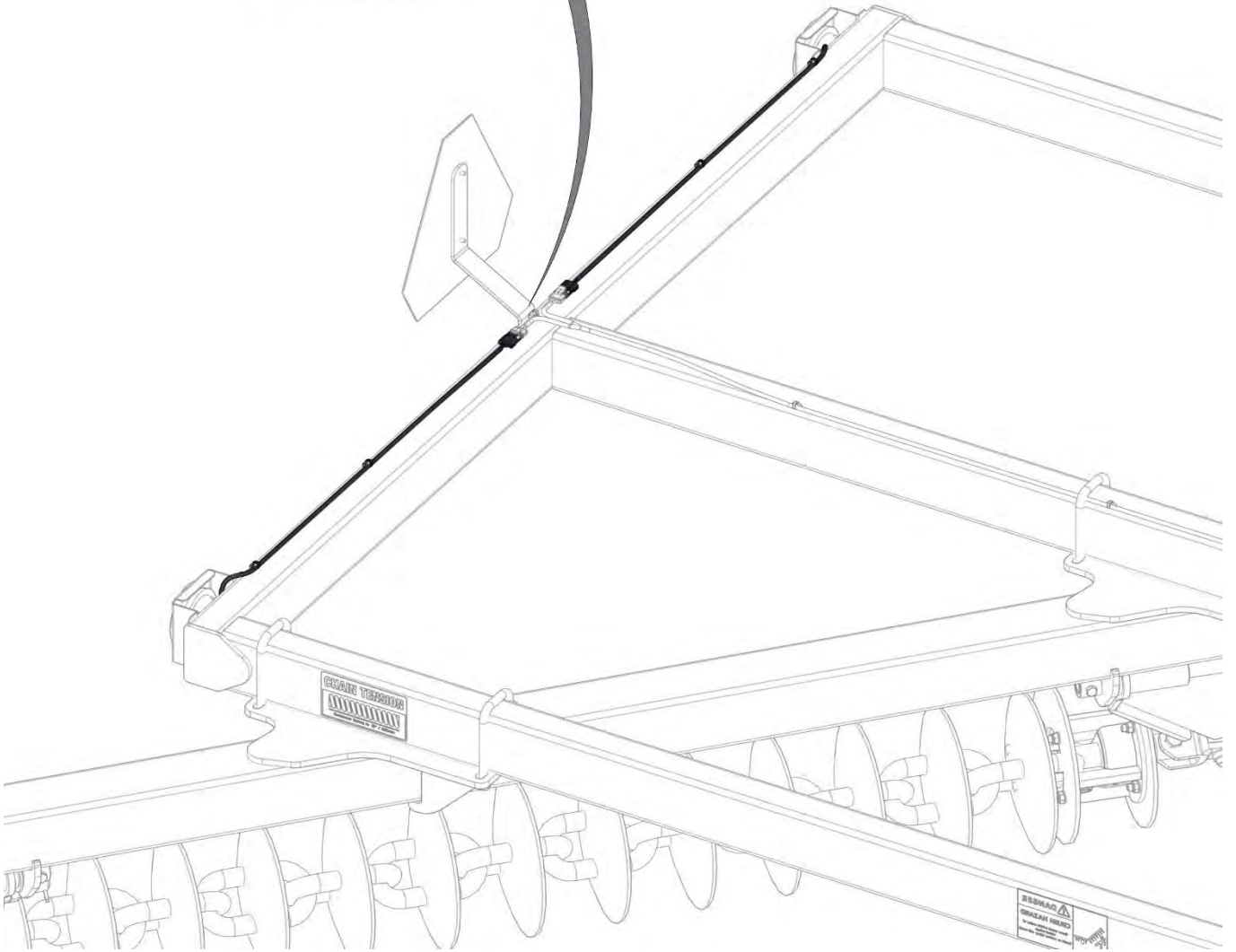
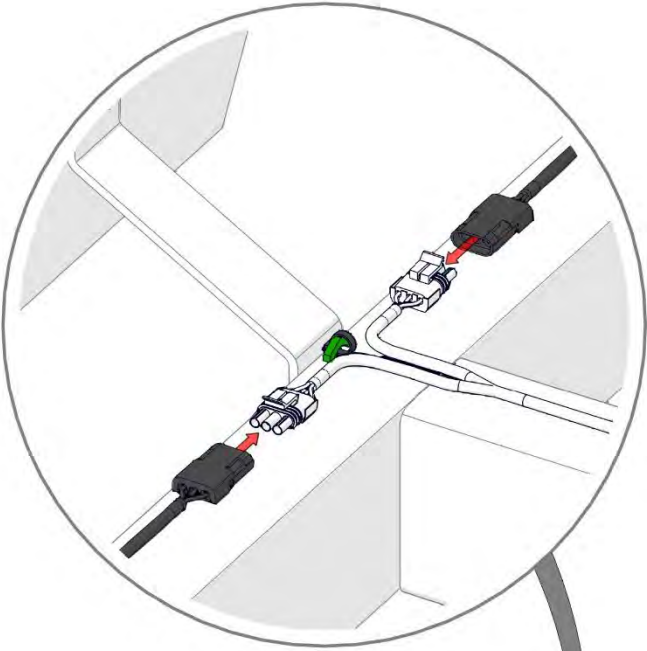

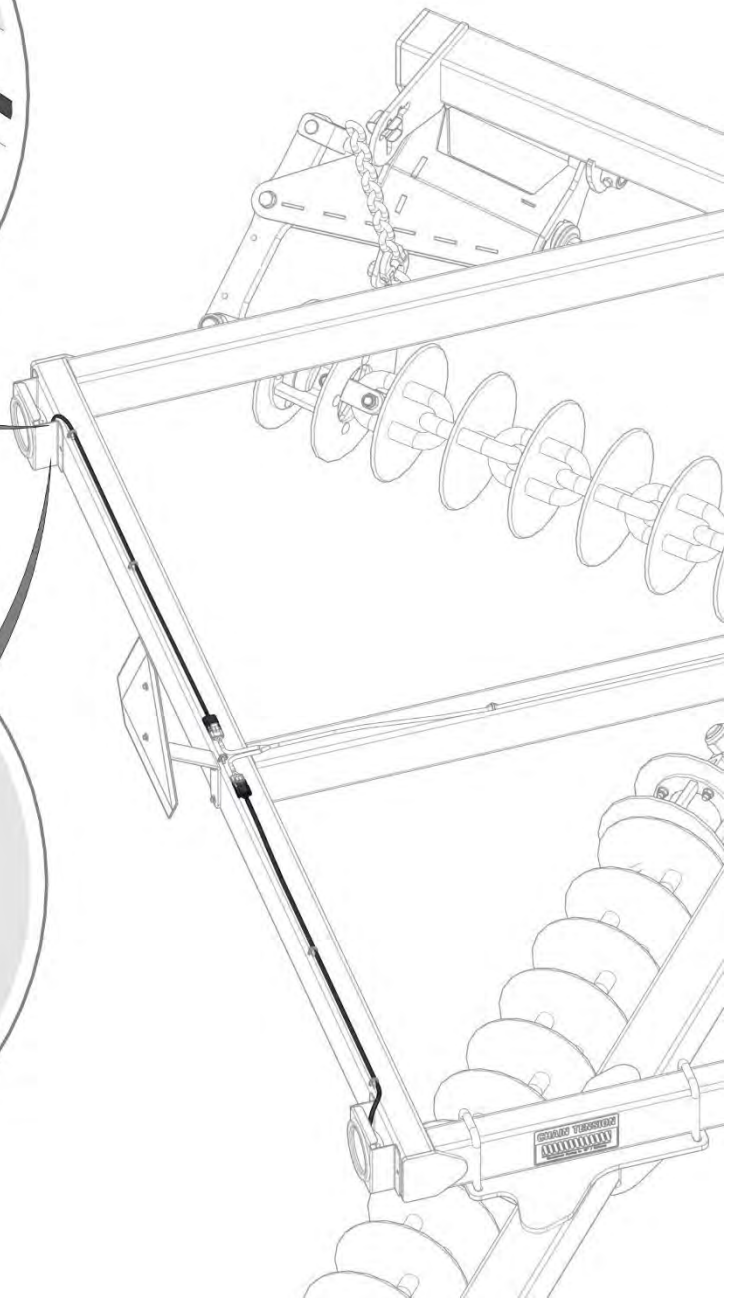
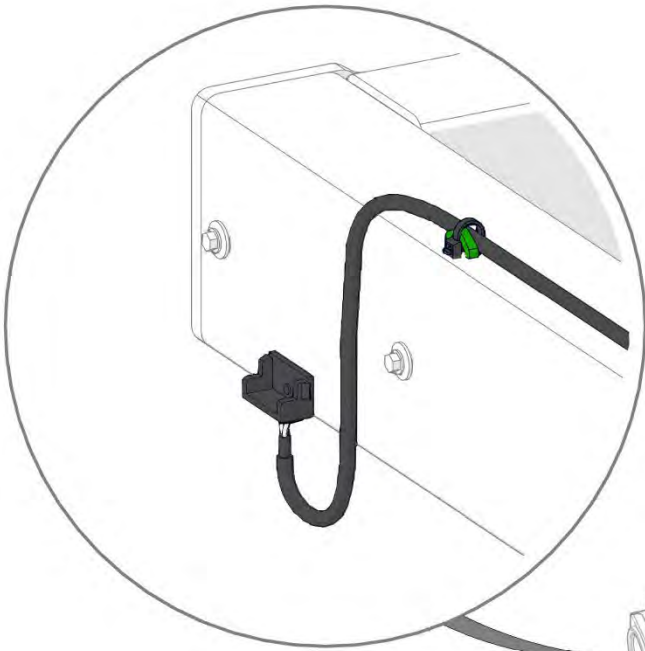



SECTION 6
CHAIN ASSEMBLY

SECTION 6 CHAIN ASSEMBLY

Chains

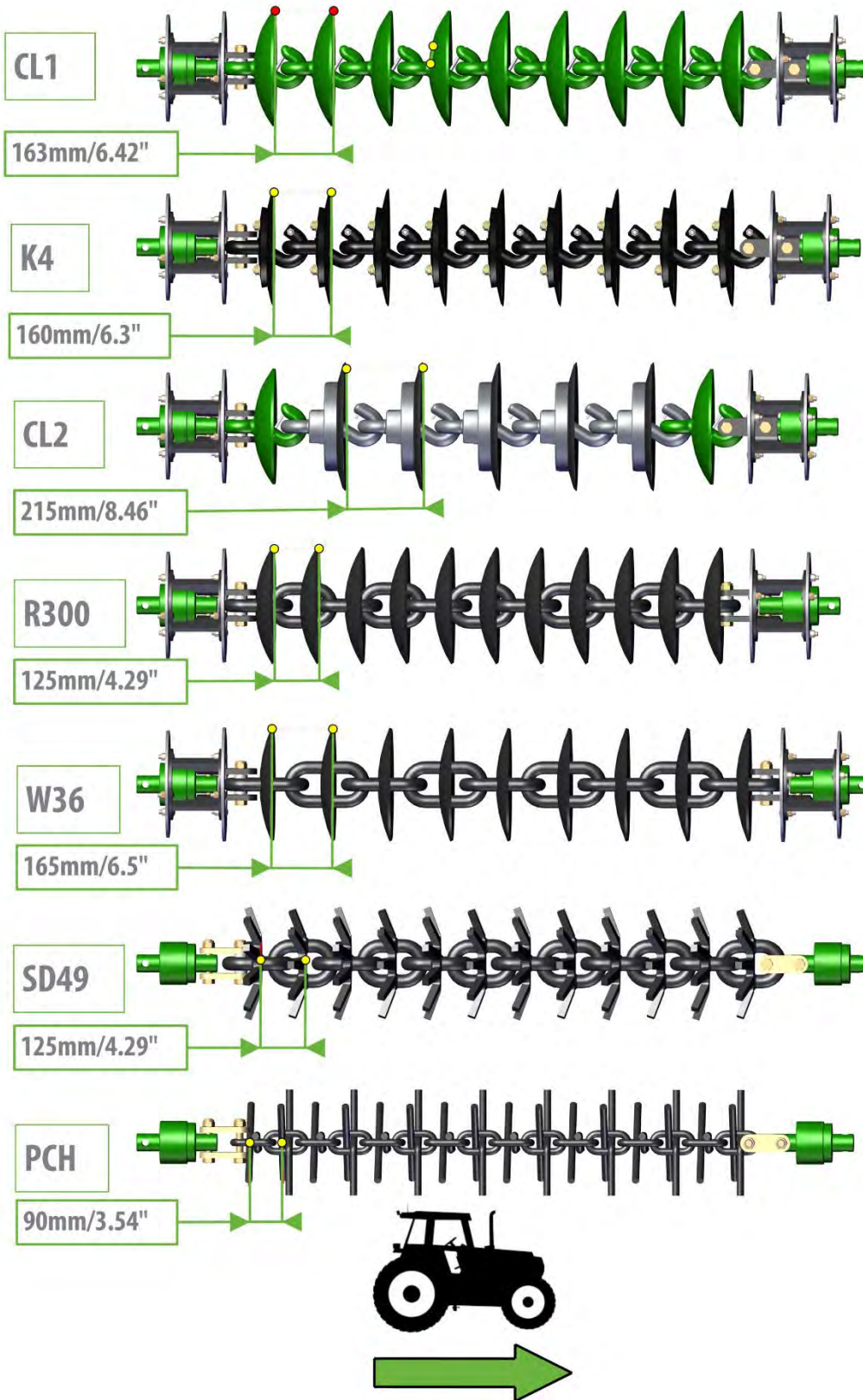

CL1 Chain

Item No.	Description	Number
1	Nyloc Nut M20/24	0221-NYL20/24
2	M20 x 110 / M24 x 120 grade 10.9 ZP Short Thread Bolt	0211-20110ST/0211-24120ST
3	20/24mm Bolt Swivel Unit	0802-PCHB55 / 0802-PCHB553
4	Tapered Chain End Hub	0810-45-5
5	Disc Chain Spacer	0801-253755
6	Roll Pin Zinc Plated 3/8" x 2"	0262-3-8X2
7	CL1-B Chain Disc Link	0803-CL1
8	TCE Blade Large	0800-767
9	TCE Blade Small	0800-766
10	Nyloc Nut M12	0221-NYL12
11	Washer Flat M12	0231-F12

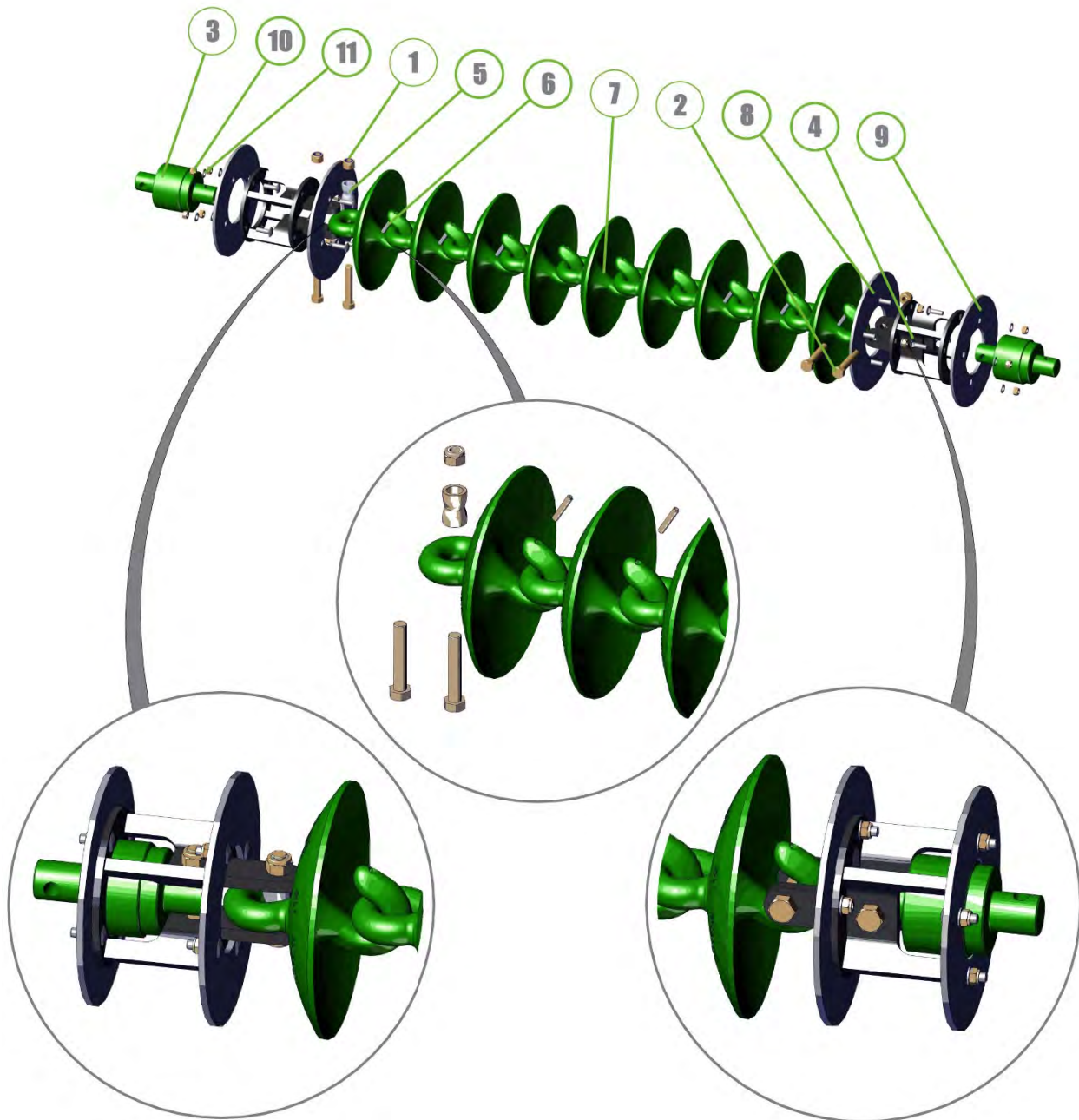

Fitting Cast Link Pins

Please install cast link retaining Pins (3/8" x 2" Roll pin, part number 0262-3-8X2) on all cast disc links. Failure to do this could lead to the discs becoming dislodged during transport causing severe damage or injury.

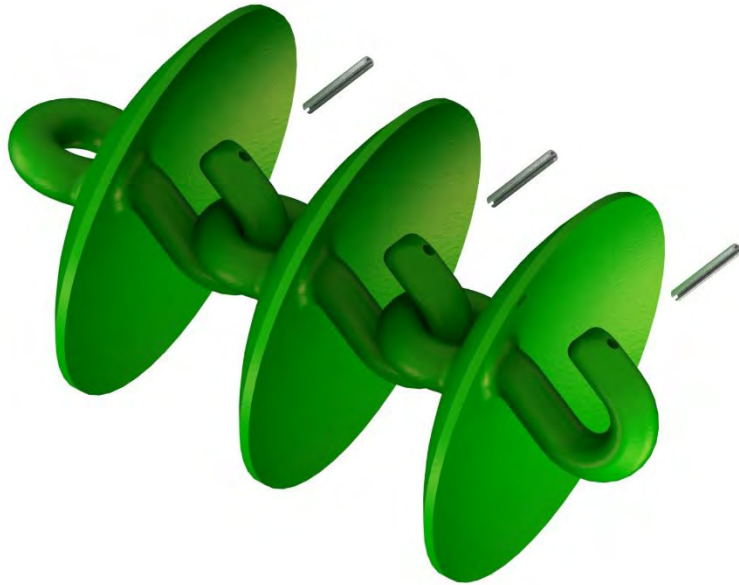
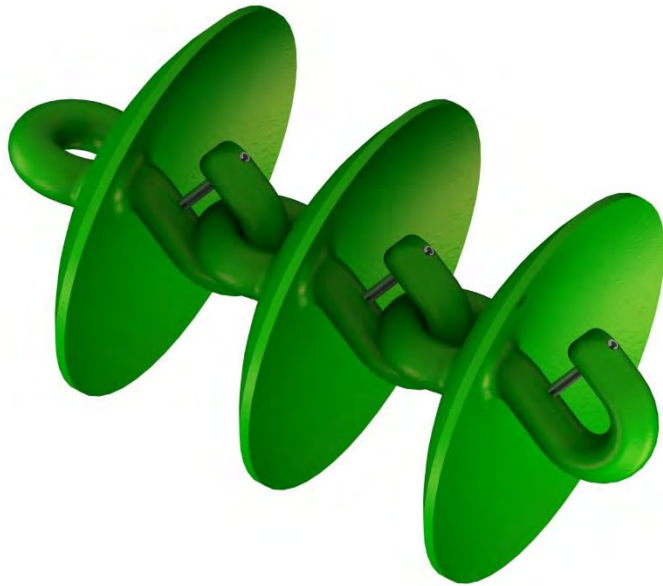

K4 Chain

Item No.	Description	Number
1	20mm Bolt Swivel Unit	0802-PCHB55
2	Nyloc Nut M20	0221-NYL20
3	M20 x 110 Class 10.9 ZP Short Thread Bolt	0211-20110ST
4	Tapered Chain End Hub	0810-45-5
5	Disc Chain Spacer	0801-253755
6	K4 Disc Assembly	0803-K4
7	Nyloc Nut M12	0221-NYL12
8	TCE Blade Large	0800-767
9	TCE Blade Small	0800-766
10	Nyloc Nut M12	0221-NYL12
11	Washer Flat M12	0231-F12

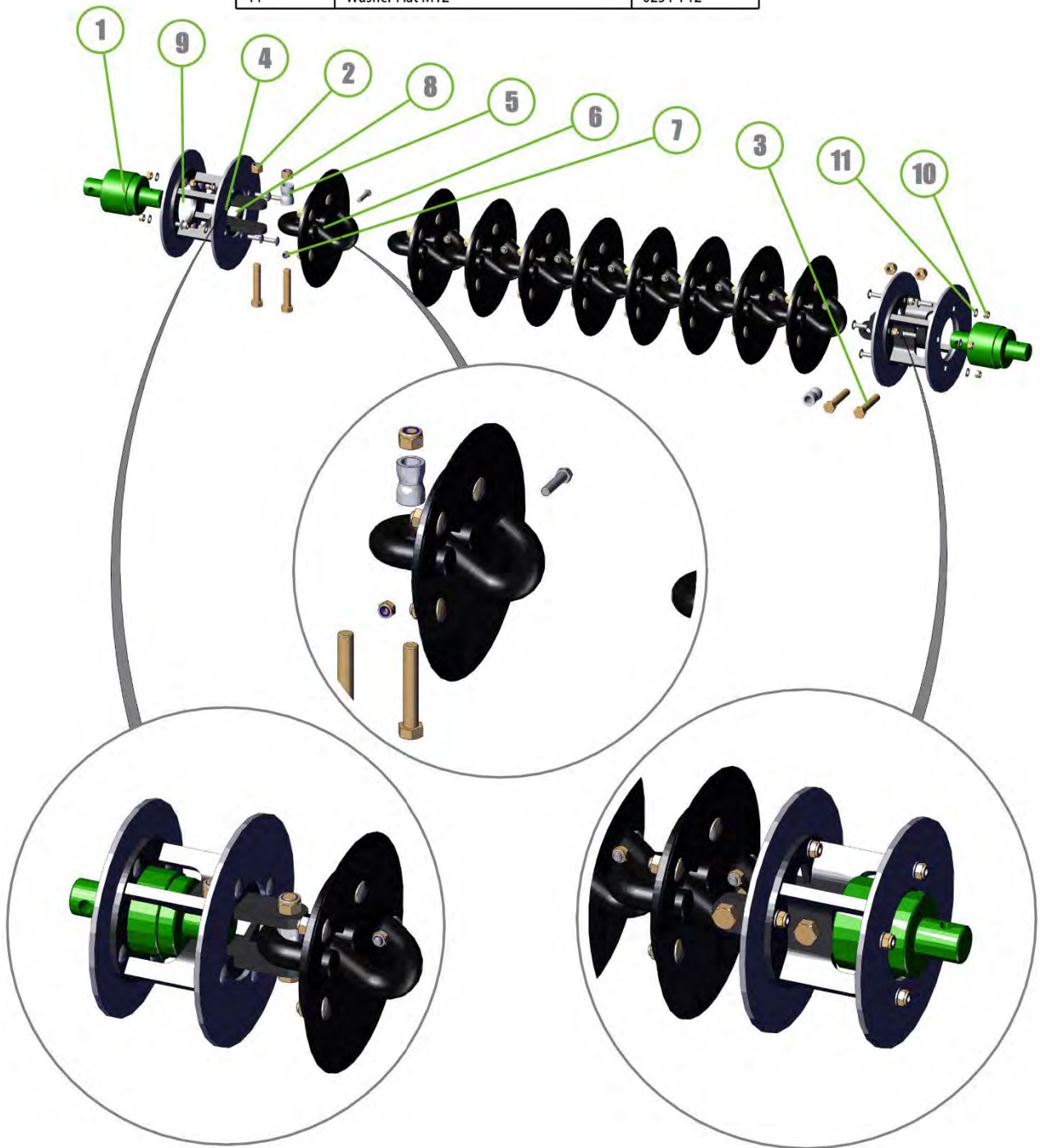

W36 Chain

Item No.	Description	Number
1	W36/25 Chain Link	0803-W36
2	20mm Bolt Swivel Unit	0802-PCHB55
3	Tapered Chain End Hub	0810-45-5
4	Disc Chain Spacer	0801-253755
5	Nyloc Nut M20	0221-NYL20
6	M20 x 110 Class 10.9 ZP Short Thread Bolt	0211-20110ST
7	TCE Blade Large	0800-767
8	TCE Blade Small	0800-766
9	Nyloc Nut M12	0221-NYL12
10	Washer Flat M12	0231-F12

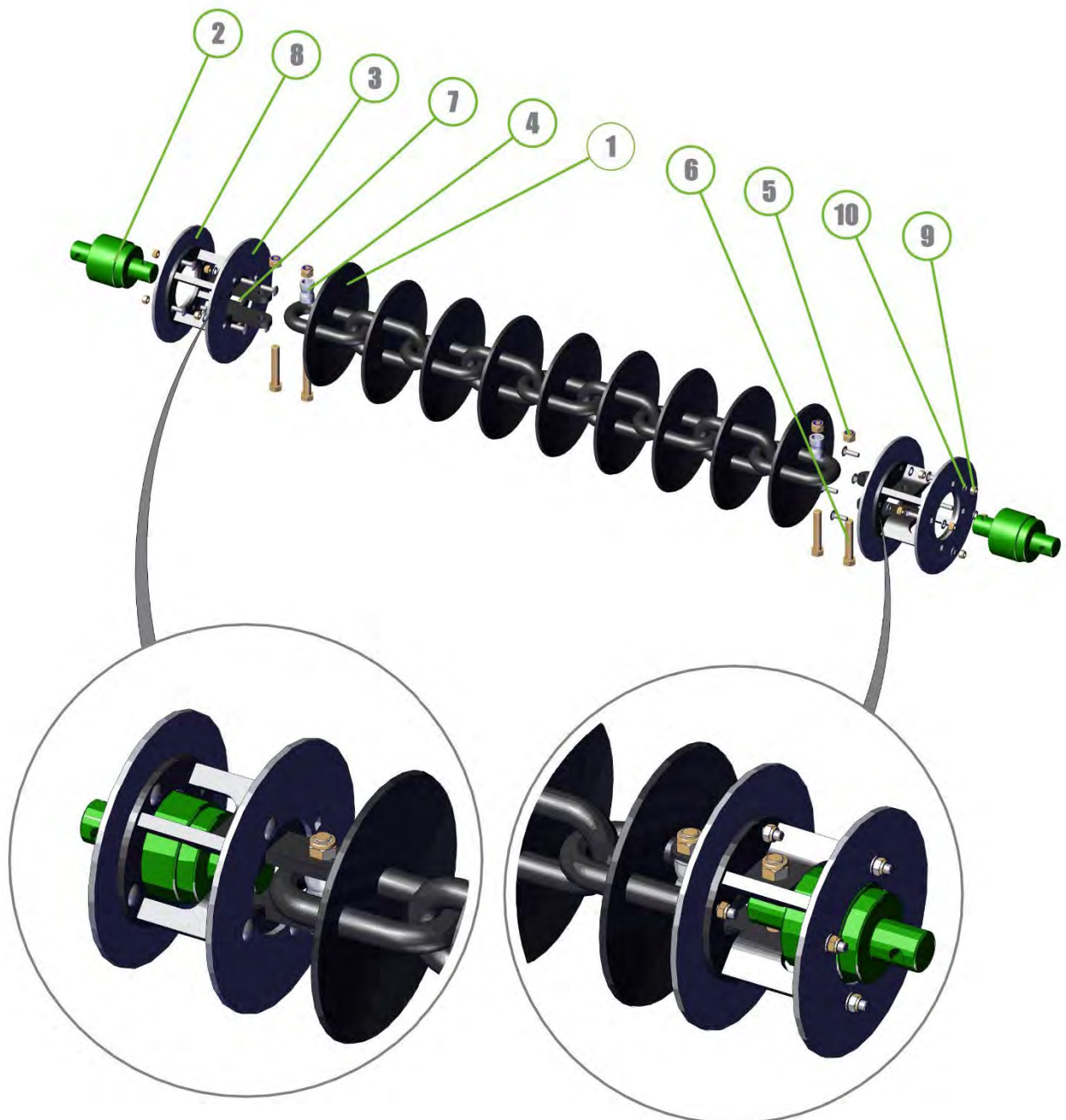

Spike Disc (SD49) Chain

Item No.	Description	Number
1	10 Spike Disc Chain 49/27/5	0803-SD49
2	Tie Plate For 20mm Bolt/ Tie Plate For 24mm Bolt	0800-83.2 / 0800-83.3
3	20mm Bolt Swivel Unit	0802-PCHB55
4	Disc Chain Spacer	0801-253755
5	M20 x 110 Class 10.9 ZP Short Thread Bolt	0211-20110ST
6	Nyloc Nut M20	0221-NYL20

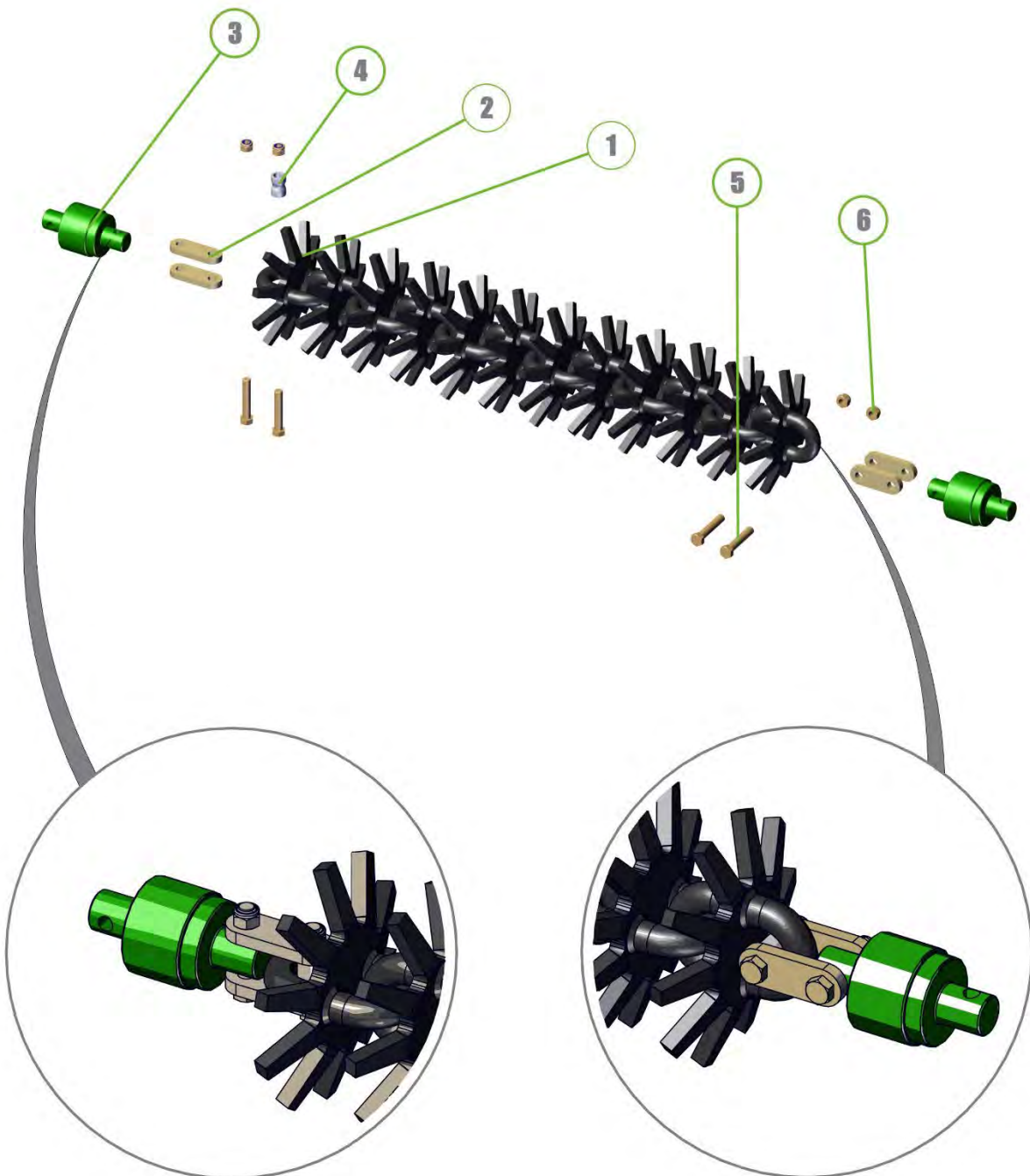
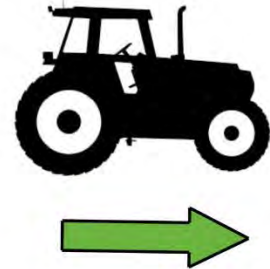

Disc Chain Lengths and Quantities

12X Model	Length	CL1/W36	CL1	W36	SD49	K4
Front Left	7' 1-39/100" / 2.169m	CL1 - 15	13	13	17	14
Centre	15' 10-43/100" / 4.583m	CL1 - 15 W36 - 14	28	27	37	29
Rear Right	8' 1-12/25" / 2.476m	W36 - 15	15	14	20	16

For correct chain tension, chain links may need to be removed from the end of the chain as follows:

CL1 Disc Chain - unhook disc chain link/s from end of the disc chain

Spiked Disc Chain - cut a disc chain link from the end of the disc chain

W36 Disc Chain - cut a disc chain link from the end of the disc chain

K4 Disc Chain - unhook disc chain link/s from end of the disc chain

Scan the following QR code to open the removing a welded disc chain video.



FRONT CHAINSET

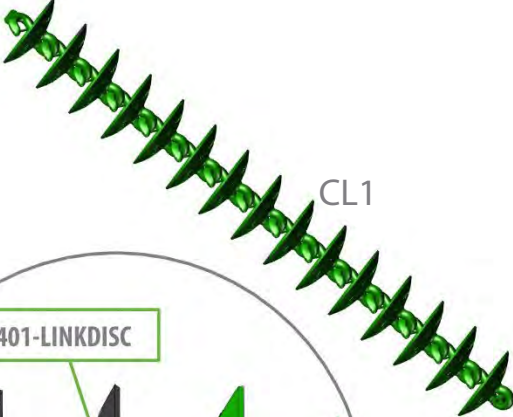

CL1

CENTRE CHAINSET

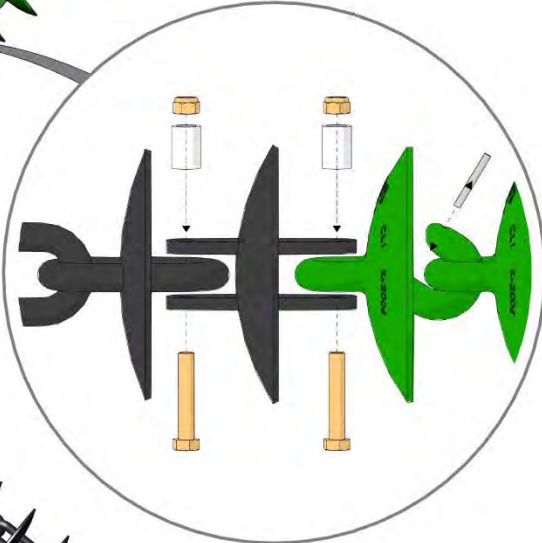
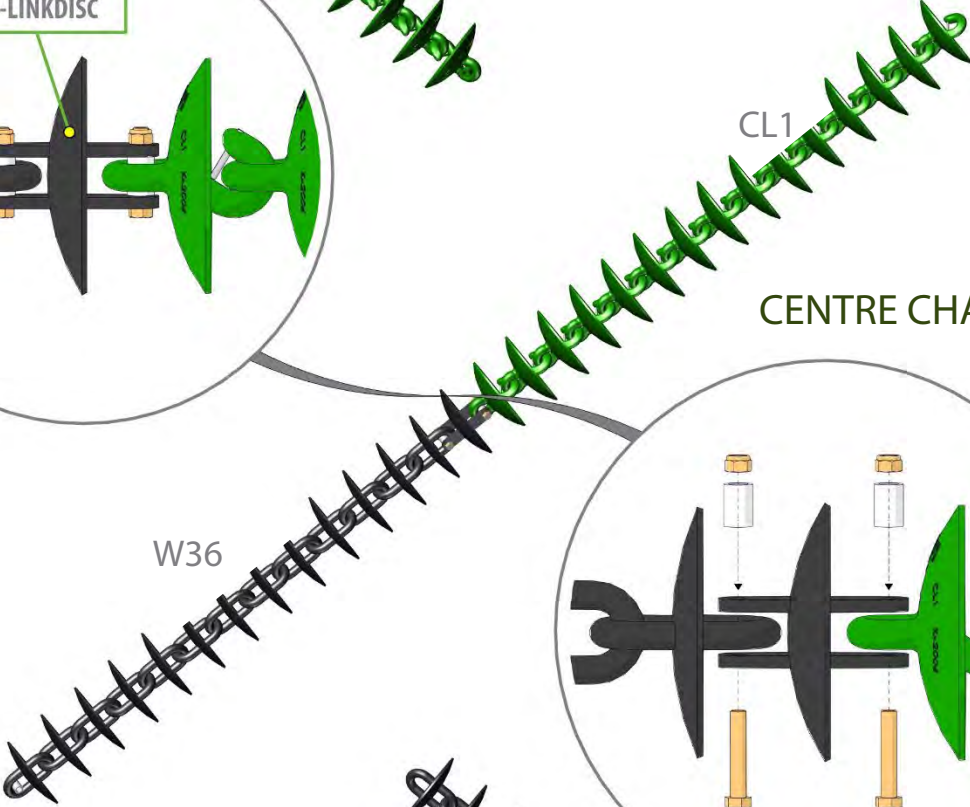

W36

W36

REAR CHAINSET

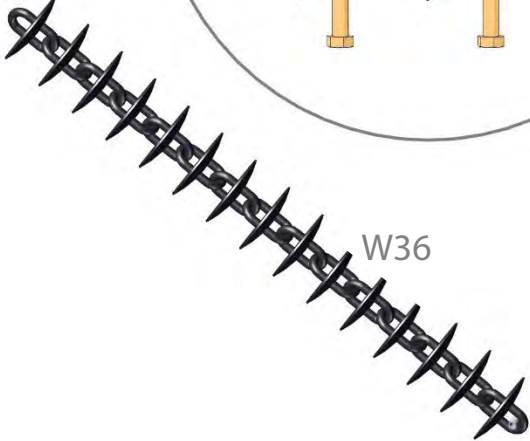



SECTION 7
DIAGRAMS & CHARTS

SECTION 7 DIAGRAMS & CHARTS

Wiring Diagram

Item No.	Part Number	Description	Qty.
1	0412-110RMLP	LED110RM Loom Plug (53102)	2
2	0412-53101RG	110RM Rubber Grommet	2
3	0412-LED110RM	LED Stop Tail Lamp	2
4	0413-2C3CW-F	3 Pin Connector Female	2
5	0413-2C3CW-M	3 Pin Connecto Male	2
6	0413-2C4CW-F	4 Pin Connector Female	1
7	0413-2C4CW-M	4 Pin Connector Male	1
8	0413-82194	Heavy Duty Metal 7 Pin Plug	1

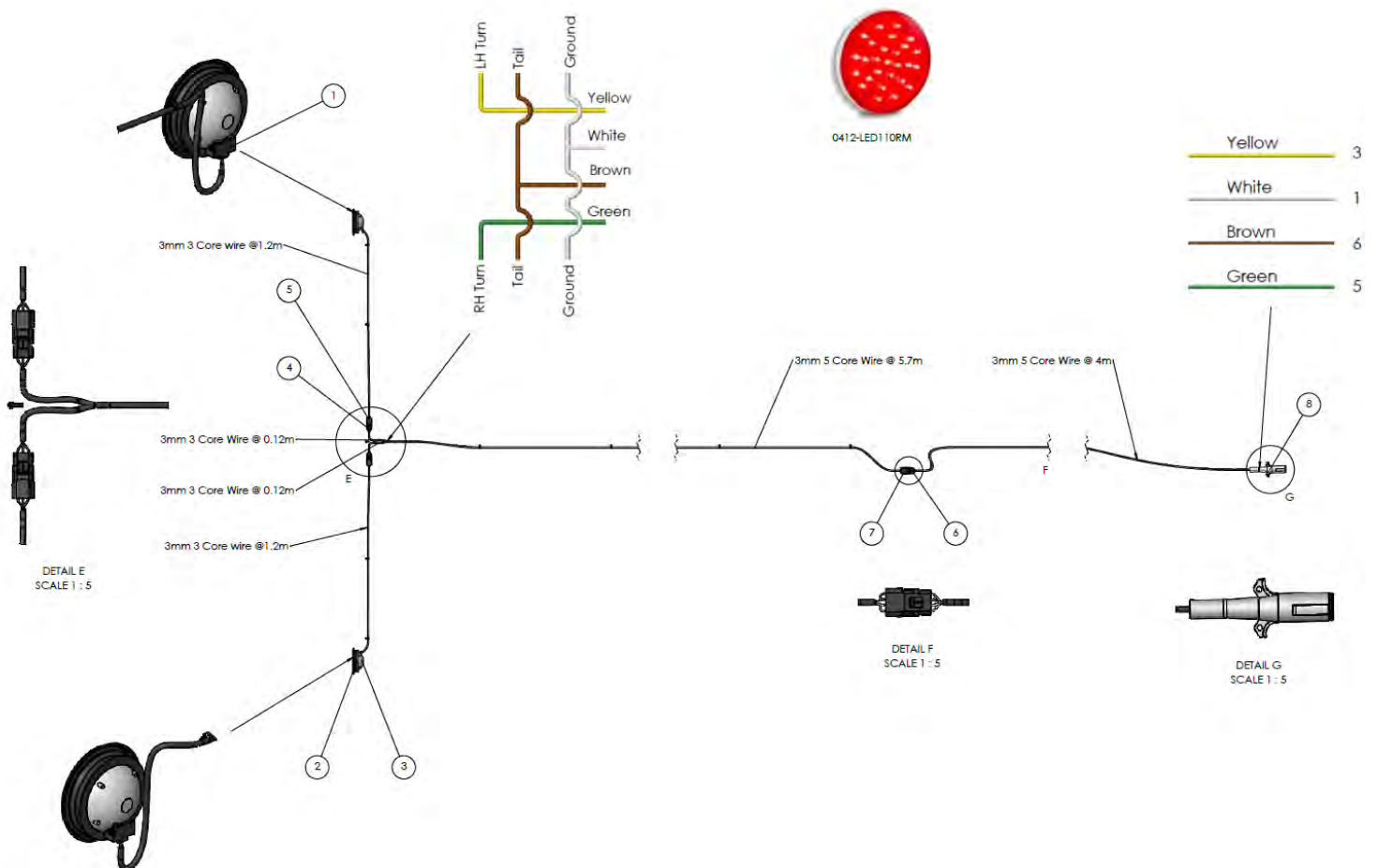

Specifications

Operating speeds

Recommended operating speeds in normal conditions with all chain types	
Operating / working speed	(6-8 mph) / (10-12 km/h)
Transporting / towing speed	(15 mph) / (25 km/h)

Tire pressure

Tire size	Ply	KPA	PSI
31/13.5-15	12	206	30

12X specifications

Model	12X
Operating width	14' 9-1/2" / 4.51m
Transport width	14' 9-4/5" / 4.52m
Transport height	6' 3-22/25" / 1.93m
Transport length	30' 9-23/25" 9.40m



SECTION 8
CHAIN SETTINGS

Chain Tension

Importance of Chain Tension

Operational

Chain tension is critical to achieve a smooth and level seedbed. A correctly tensioned, monitored and maintained chain will deliver the results you need. Incorrect chain tension can lead to:

- Uneven results across the cut width of the machine
- Uneven weed control
- Unsatisfactory incorporation
- Ineffective levelling
- Accelerated or premature chain link wear (not covered by warranty)
- Chains failing to engage with transport locator's when folded
- Machine damage when folding or unfolding
- Uneven field surface with ridges and furrows being created.

A correctly adjusted machine will not cause this problem.

Chain Tension - Modules

1. Loosen the lock nut on the module tension rod.
2. For correct chain tension, tighten the adjusting nut clockwise until the outside face of the spring retaining washer is flushed with the face of the tension body. Spring length of 330mm / 1' 1".
3. If more than 150mm / 5-29/32" of tensioner thread is visible, then remove one link from the chain set to maintain correct chain tension.
4. Retighten the lock nut.

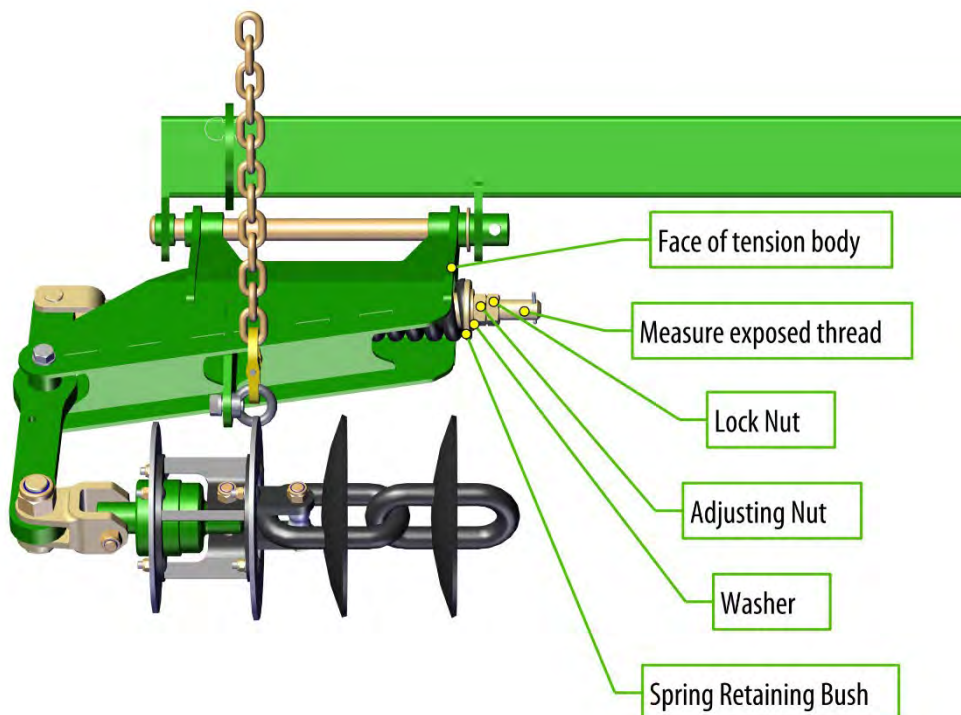

1

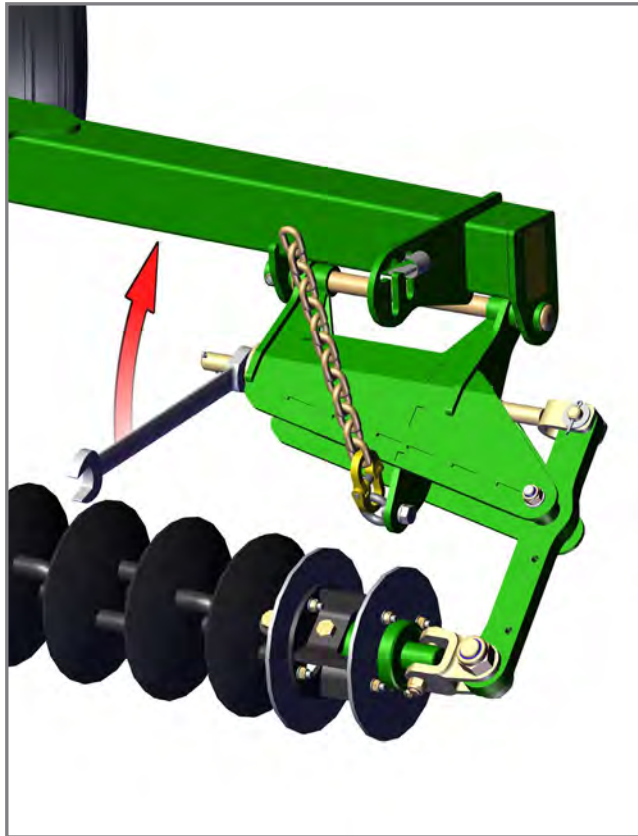

2

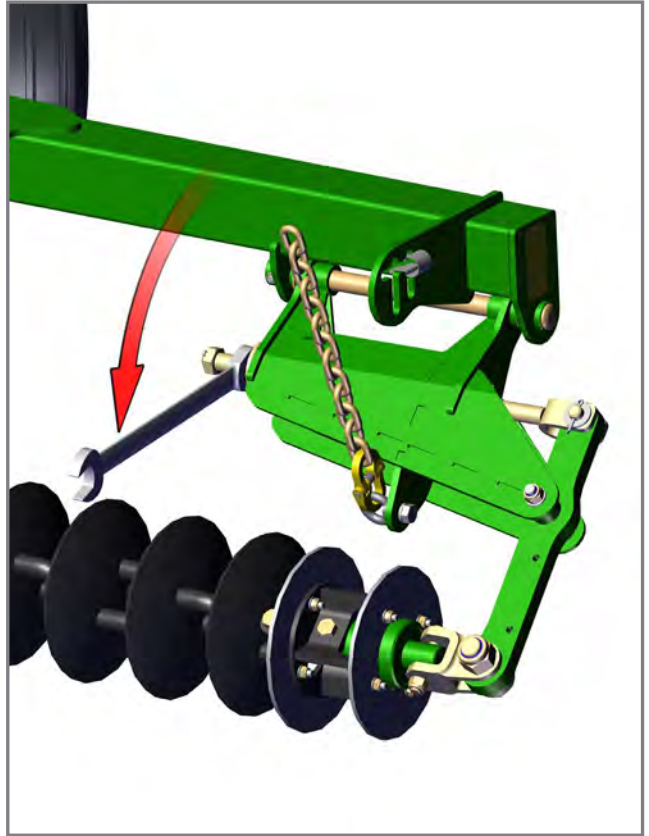

3

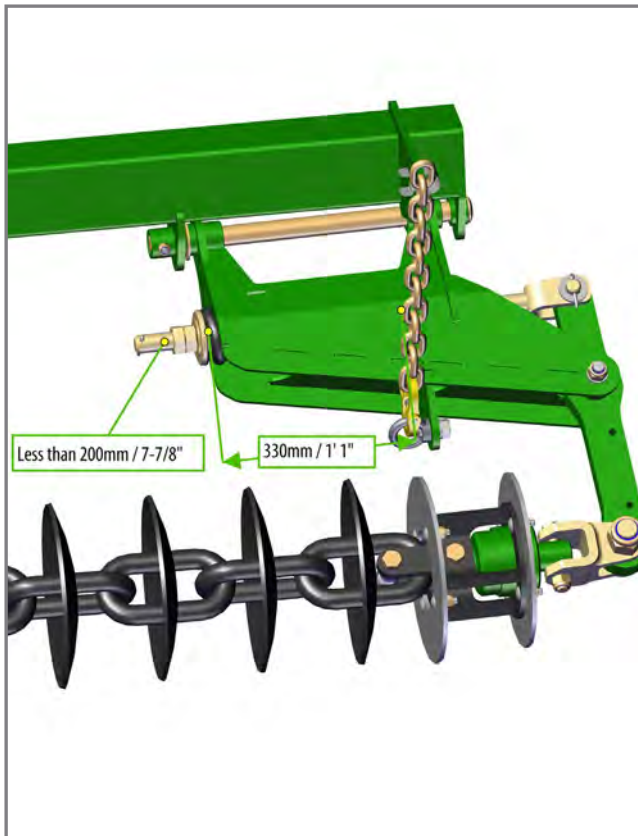

4

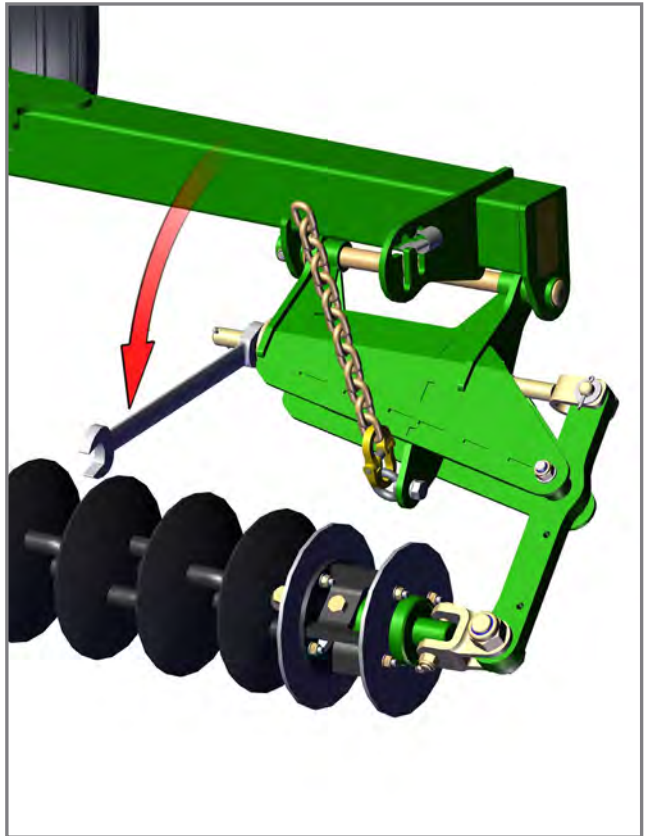

Chain Curve

Correct chain tension will ensure that the entire length of discs will roll as one. This minimises the movement between each link. If a chain is not adjusted and runs loose, each link acts as a universal joint as the curved chain rolls along. The wear rate between each link is greatly accelerated and can lead to premature failure. The chain should not wear out before the discs are worn down.

ONLY POOR ADJUSTMENT CAUSES PREMATURE WEAR

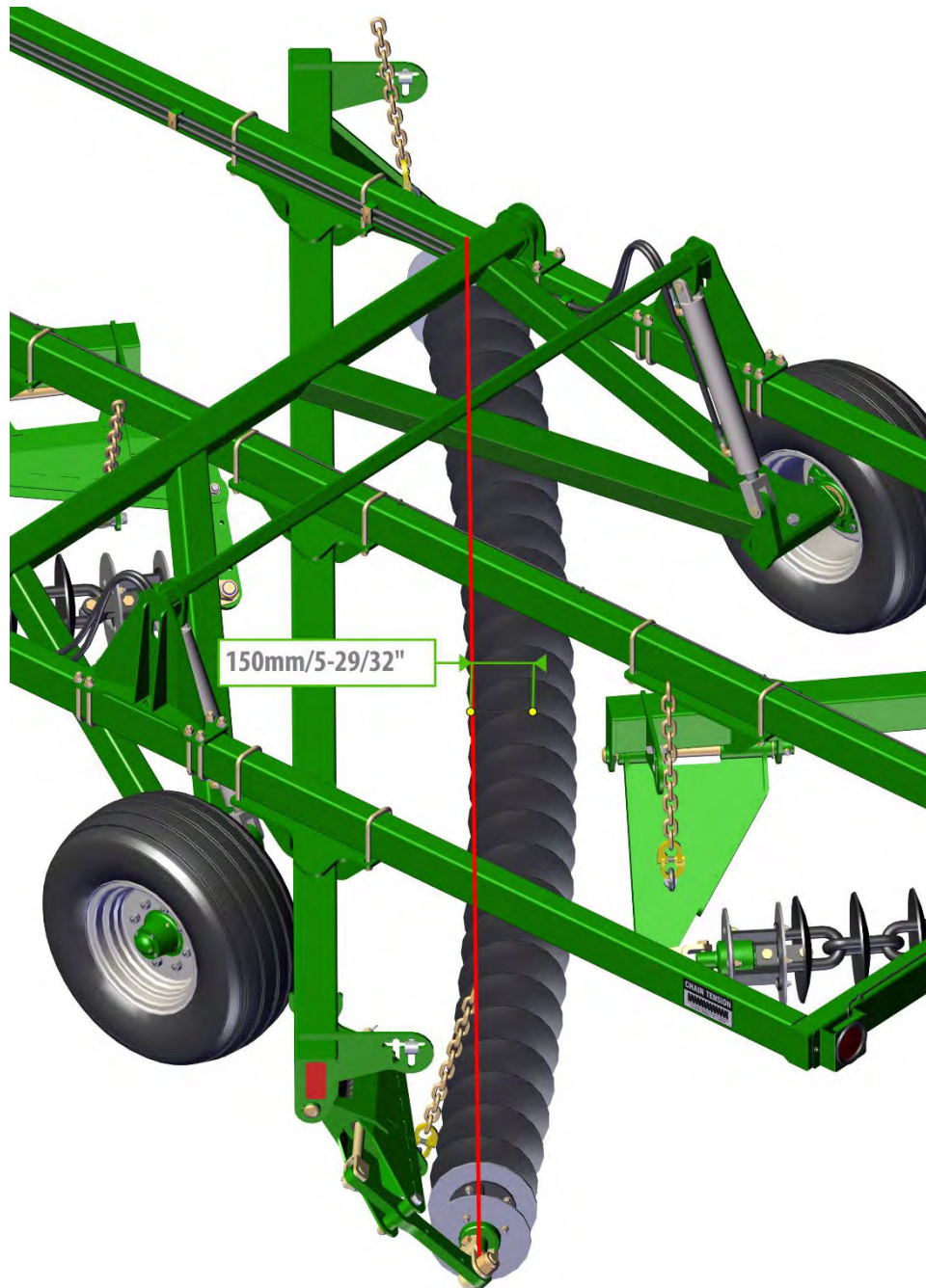

Indicator line shows acceptable curvature when operating.

Chain Mount Arm Height Adjustment

1. Use tractor hydraulics to raise the module chain or chain mount plate that requires adjustment. Position a suitable block or stand to support the arm. Using the tractor hydraulics, lower the machine until the height adjusting chains are loose.

2. Remove spring retaining clip. Slide chain up to the top of the slot in lifting arm to pass the chain through the cross at top of plate.

3. Slide chain back down to the bottom when the desired position is reached. To achieve "one link" of adjustment, lift chain to the top of the slot, pass one link through the slot and rotate 90 degrees to allow the next link in the adjusting chain to lower into the same slot.

To achieve "half link" of adjustment lift the chain to the top of the slot and slide chain horizontally and lower the same link into the second slot. This will raise or lower the chain mount plate by half a link depending on which slot the chain started in. Any excess chain can be fed back through the second slot.

4. Install retaining clip. Remove stand.

Step 1



Step 2



Step 3



Step 4



Frame height adjustment

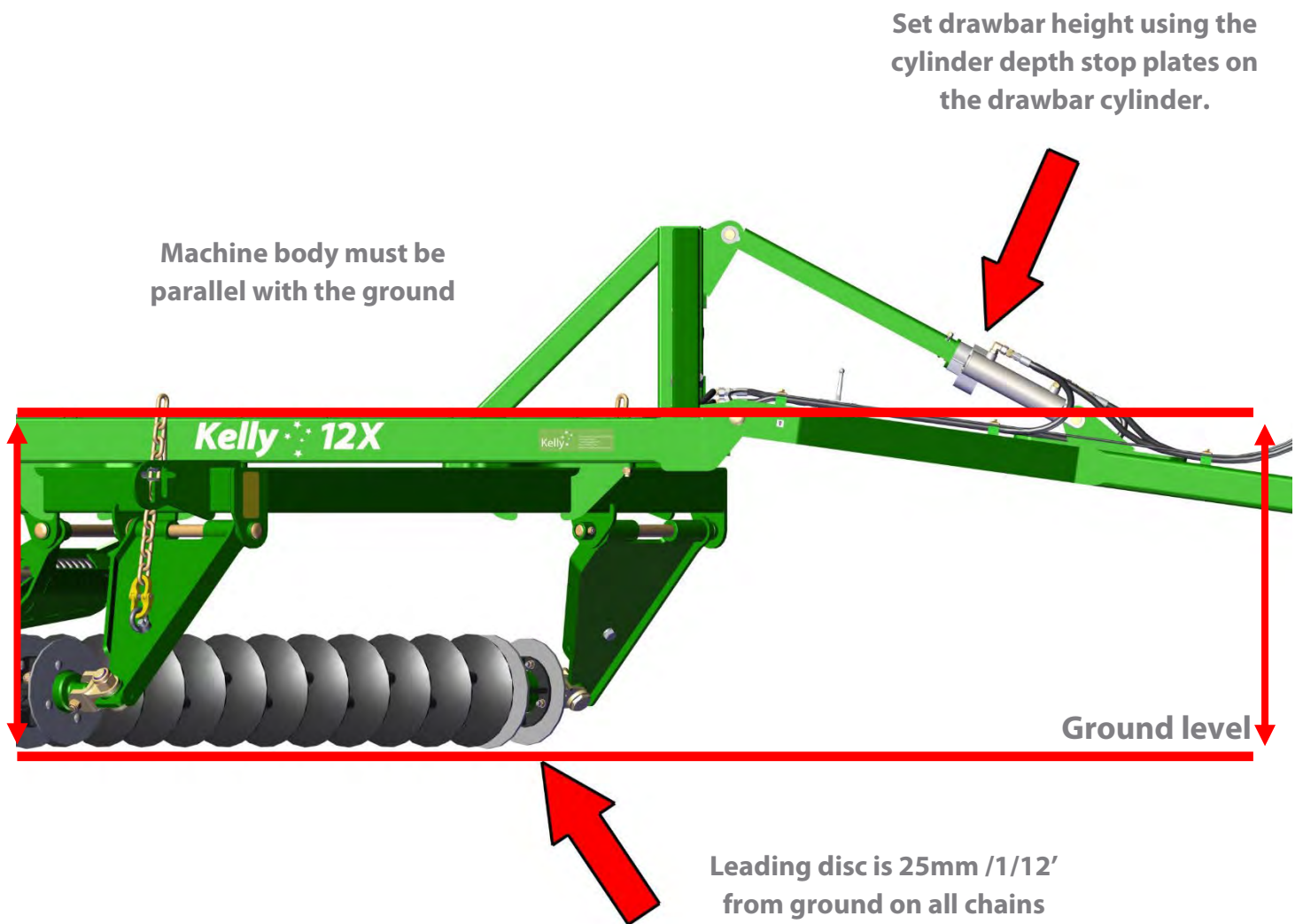

Check the length of the height adjusting chains on the two front chain mount plates. There should be no slack in the chain and about 25-51mm / 1/12'-1/6' of gap between the ground and the bottom of the first disc machine near the centre line.

