

# KELLY

Better Tillage. Better Tomorrow.

# Operating Instruction Manual

## KELLY TILLAGE SYSTEM 12X

KEOPM-H-01012023



SERIAL NUMBER:

# KELLY

Phone +61 8 8667 2253  
Email [sales@kellytillage.com](mailto:sales@kellytillage.com)  
[kellytillage.com](http://kellytillage.com)

**Booleroo (Head Office)**  
684 Kelly Road,  
Booleroo Centre SA 5482

**Adelaide Office**  
28 Greenhill Road,  
Wayville SA 5034





# Thank you for choosing a KELLY product.

We trust that you find the following manual clear and easy to follow. If you should require additional customer support or assistance, please do not hesitate to contact us.

Spare parts can be purchased, as required, through your local dealer or by contacting KELLY directly.

The KELLY team values your feedback. Should you have any difficulties that you wish to raise, suggestions for improvement or modifications that you feel would enhance our products we look forward to hearing from you.

## Contact Us

### Australia

#### Booleroo (Head Office)

684 Kelly Road,  
Booleroo Centre SA 5482

+61 8 8667 2253

Monday - Friday  
8am - 4pm ACDT

#### Adelaide Office

28 Greenhill Road,  
Wayville SA 5034

+61 8 8667 2253

Monday - Friday  
8am - 4pm ACDT

## Global Locations

#### Eastern Canada

Leading Edge Equipment  
[www.leadingedgeequipment.ca](http://www.leadingedgeequipment.ca)

1-519-421-3223

Monday - Friday  
8am - 4pm EST

#### Western Canada

Adair Sales & Marketing Co Inc  
[www.adairreps.com](http://www.adairreps.com)

1-306-773-0996

Monday - Friday  
8am - 5pm CST

#### United States

Hood & Company

+1 417-865-2100

Monday - Friday  
8am - 4pm CST

#### Europe

[kellytillage.com](http://kellytillage.com)

+61 8 8667 2253

Monday - Friday  
8am - 4pm ACDT

#### Argentina

Giorgi Sa Maquinarias Agrícolas  
[www.giorgi.com.ar](http://www.giorgi.com.ar)

+54 3464 493512

Monday - Friday  
8am - 5pm ART

#### South Africa

Desmond Whitfield CC

+27 82 567 8245

Monday - Friday  
8am - 4pm SAST

# Contents

## Safety Information

Signal words	4
General operation	4
Transport	4
Hydraulics	4
Maintenance & inspection	4

## Section 1 - Warranty

Warranty policy	5
Product registration form	6

## Section 2 - Machine Operation

Before operation	7
Pre-operation checklist	7

## Section 3 - Chain Operation & Correct Setup

Importance of good chain setup	8
Chain tension	8
Chain curve	10
Chain mount arm height adjustment	11
Frame height adjustment	12

## Section 4 - Maintenance & Inspection

Maintenance and inspection	13
Recommended maintenance checklist	14
Chain inspection	15
Trouble shooting	15

## Section 5 - Specifications

Operating speed	16
Tyre pressure	16
Machine specifications	16
Bolt torque settings	17
Disc chain lengths and quantities	18

## Section 6 - Pre-delivery checklist

Pre-delivery checklist	21
Notes	22

**Register within 2 months of purchasing your machine to receive an additional 12 months warranty.** Find the registration information on page 6.

# Safety Information



**Read all assembly instructions and study all photographs thoroughly before assembling the unit.**

**Please note:** Left and right is determined by standing behind the machine and looking to the front.

## Signal Words

A signal word - DANGER, WARNING, or CAUTION, is used with the safety alert symbol.

When you see this symbol on your machine or in this manual, be alert to instructions involving your personal safety and the safety of others. Failure to follow these instructions can result in injury or death.



**DANGER** - Indicates an immediate hazardous situation that, if not avoided, will result in **DEATH OR SERIOUS INJURY**.



**WARNING** - Indicates a potentially hazardous situation that, if not avoided, could result in **DEATH OR SERIOUS INJURY**.



**CAUTION** - Indicates a potentially hazardous situation that, if not avoided, may result in a **MINOR OR MODERATE INJURY**.

Carefully read all safety points in this manual and on your machine. Keep all safety decals in good condition and replace ones that have been worn or lost. Replacement decals are available by contacting your local dealer.

***If any safety decals are missing please contact your local dealer immediately and do not use the machine.***

## General Operation

- Proceed cautiously under overhead powerlines and around power poles, as contact may result in the operator suffering a severe electrical shock.
- Never allow anyone within the immediate area when operating machinery.
- Stand clear when raising or lowering wings.

## Transporting

- Always travel at a safe speed. NEVER EXCEED 25kph.
- Ensure transporting transport safety lock valves are closed during transport to ensure machine is transported safely (Fig.13 & 14).
- Ensure your speed is low enough for an emergency stop to be safe and secure and reduce speed prior to turns.
- Ensure safety chain is attached correctly to the towing vehicle.
- Please refer to your own country, state, provincial, county or municipality laws on the rules of transporting farm machinery on roads.
- Ensure that disc or prickles chains are engaged in chain guides and supports. Disc or prickles chain should be clear of the ground.
- Be aware of the height, length and width of the machine. Beware of obstacles and overhead powerlines.
- Use approved accessory and necessary warning devices on the road during both day and night time transporting.

## Hydraulics

- **NEVER** remove hydraulic hoses or ends unless the machine is in either transport position or fully extended in working position. Relieve all hydraulic pressure before disconnecting hydraulic hoses and fittings.
- Ensure all fittings and hoses are in good condition.
- Do not search for high pressure hydraulic leaks without hand and face protection. A leak can penetrate the skin, thereby requiring immediate medical attention.
- Double check that all is clear before operating hydraulics.
- Maintain proper hydraulic fluid levels and pressure.

## Maintenance and Inspection

- Good maintenance is your responsibility.
  - Regular maintenance and inspection is imperative
- Maintenance guidelines can be found in section 4.*



# Section 1 - Warranty

## Warranty Policy

**The warranty for the machine will be null and void if any non-genuine KELLY part is used on the machine.**

KELLY guarantees its products against faulty workmanship and materials for twelve (12) months from date of purchase. Disc Chain, Prickle Chain and Swivel Bearings units are considered to be wear items and it's reasonable to expect that these parts may need to be replaced over time.

KELLY offers an additional 12 month warranty if the machine is registered within 2 months of purchasing the machine. Machine registrations can be completed by the customer or dealer on the KELLY website or the KELLY supplied warranty registration form in the operator manual.

The KELLY warranty policy does not cover misuse, modifications, damage during transit or product that has not been maintained per the KELLY maintenance procedures outlined in the relevant product manual.

Failure to properly maintain the machine or blatant misuse shall result in the warranty being null and void.

KELLY reserves the right to request written, photographic or video documentation prior to any warranty authorisation.

All warranty queries and requests for authorisation can be directed to [warranty@kellyengineering.com.au](mailto:warranty@kellyengineering.com.au).

Any warranty repair, service or modification to products must be performed by an authorised KELLY repairer and pre-approved by KELLY in writing prior to any work being carried out.

KELLY will issue an "Authorised Returns" notice for any faulty parts to be returned at the request of the company.

Any claim for warranty, labour or parts must be completed on the prescribed warranty claim form found on the KELLY website.

Warranty claims are to be lodged within 30 days of completion of work. If further information is requested on the claim from the Warranty Officer, you have 30 days to provide the information. If you fail to adhere with the above instructions the warranty claim may be declined.

Upon completion and approval of this claim the dealer will receive a credit to their account.

**To activate the warranty a Machine Registration form must be lodged with the manufacturer.**

**Complete the Machine Registration form online**  
Visit the **Resources** page on our website

Receive an additional **12 months warranty** by registering your product within 2 months of purchasing.  
*Simply return your completed form via email or post, or fill the online form to be eligible.*

## Purchaser/Owner

Name: \_\_\_\_\_

Address: \_\_\_\_\_

\_\_\_\_\_

Email Address: \_\_\_\_\_

Contact number: \_\_\_\_\_

Occupation: \_\_\_\_\_

## Purchasing Details

Date of Purchase: \_\_\_\_\_

Place of Purchase: \_\_\_\_\_

\_\_\_\_\_

Model Purchase: \_\_\_\_\_

Serial Number: \_\_\_\_\_

### What brought KELLY Tillage products to your attention?

Field Day	Family	Magazine/Newspaper: _____
Dealer	Website	Demonstration: _____
Friend/Neighbor	Radio	Referral Source: _____

On a scale of 1 to 10 (10 being highest) how likely are you to recommend us to friends and family?

1	2	3	4	5	6	7	8	9	10
---	---	---	---	---	---	---	---	---	----

If you scored 8 or below then what must we do to become a 10 in your opinion?

\_\_\_\_\_

\_\_\_\_\_

If you scored 9 or above then please tell us why you gave us this score:

\_\_\_\_\_

\_\_\_\_\_

### Satisfaction with dealer/agent:

Was the machine pre-delivered satisfactorily?	Yes	No	_____
Were agents well informed about the product?	Yes	No	_____
Would you recommend the agent to other farmers?	Yes	No	_____

**Please return the completed form to:**  
**Mail to:** PO Box 100, Booleroo Centre SA 5482 Australia  
**Email to:** sales@kellytillage.com

**OR complete the Machine Registration form online:**  
 Visit the **Resources** page on our website



# Section 2 - Machine Operation

## Before Operation

- Carefully study and understand this manual.
- Do not wear loose fitting clothing that may catch in moving parts.
- Always wear protective clothing and footwear.
- Be sure that there are no tools lying in or on the equipment.
- Do not use the machine until you are sure that the area is clear, particularly of children or animals.
- If this machine is being used in a dry area, or in the presence of combustibles, care should be taken to prevent fires and fire fighting equipment should be readily available.
- Familiarise yourself and other operators with the machine's operation before using.

## Pre-Operation Checklist

1	All wheel nuts, bolts and nuts are tightened to the correct torque setting
2	Split pins are in place
3	Stickers and warning signs are in place
4	Hydraulic fittings are tight and have no leaks
5	Chains are adjusted so that all springs are compressed to 330mm/ 1' 1"
6	Check swivel bearings are not seized and still turning freely



# Section 3 - Chain Operation & Correct Setup

## Importance of good chain setup

### Operational

It is imperative that the correct chain tension is maintained. Only through correct tension can a smooth and level finish be achieved in field working.

Loose chains lead to :

- Uneven performance across the width of the machine
- Uneven weed control
- Unsatisfactory incorporation
- Ineffective levelling
- Accelerated or premature chain link wear (not covered by warranty)
- Chains failing to engage with transport locator's when folded
- Machine damage when folding or unfolding
- Uneven field surface with ridges and furrows being created.

**A correctly adjusted machine will not cause this phenomenon.**

The framework should be horizontal when set on level ground. ie parallel to the ground. Fine adjustments should be made using the adjustor chains at each bearing mount plate.

## Chain Tension

1. Loosen the lock nut on the draw bolt.
2. For correct chain tension, tighten the adjusting nut clockwise until the outside face of the spring retaining washer is flushed with the face of the tension body. Spring length of 330mm / 1' 1"
3. If more than 150mm / 5-29/32" of tensioner thread is visible, then remove one link from the chainset to maintain correct chain tension.
4. Retighten the lock nut.

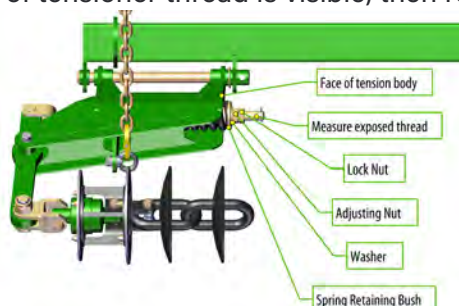



1

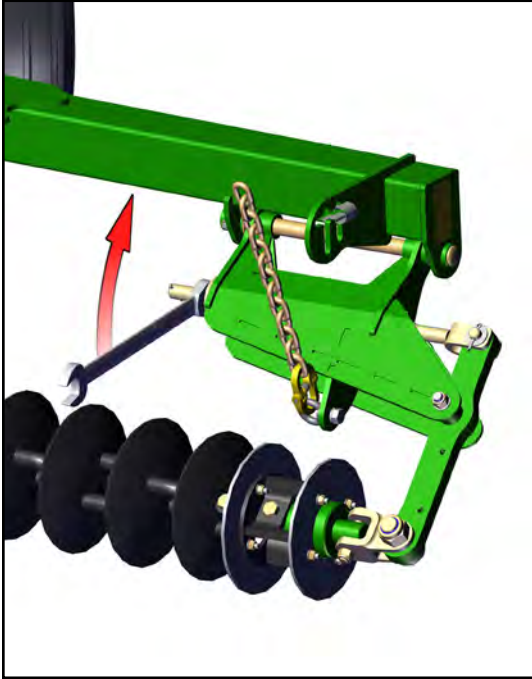

2

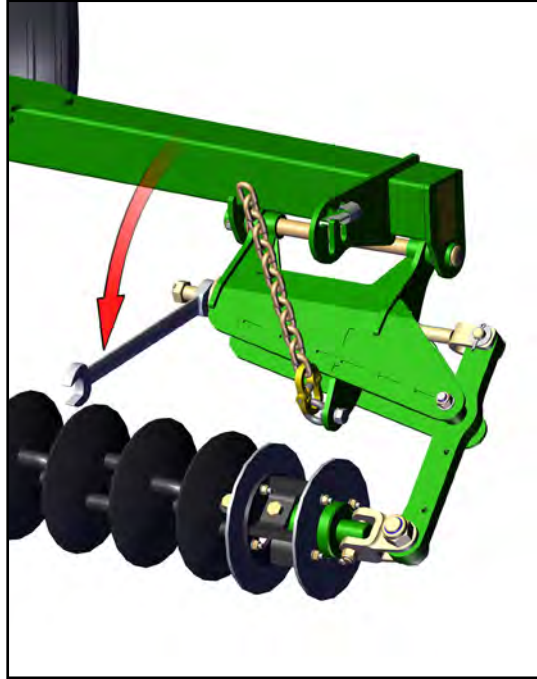

3

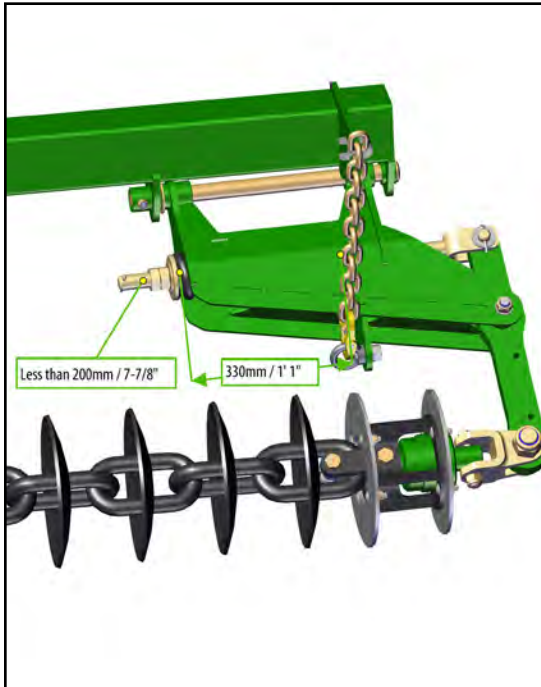

4

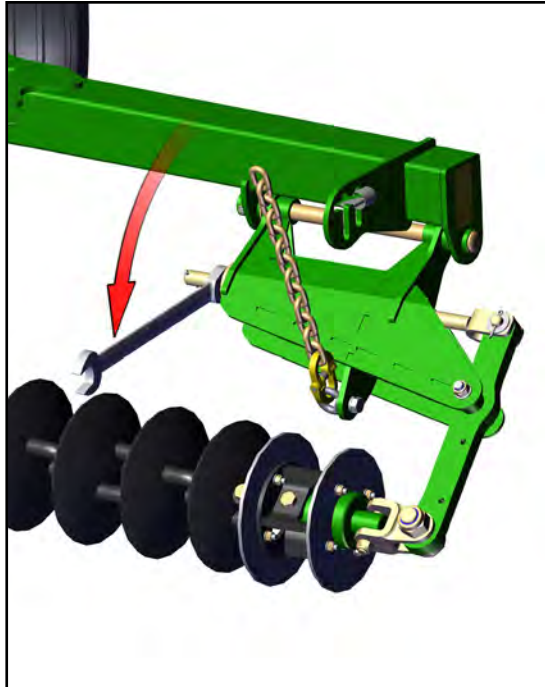

## Chain Curve

Correct chain tension will ensure that the entire length of discs will roll as one. This minimises the movement between each link. If a chain is not adjusted and runs loose, each link acts as a universal joint as the curved chain rolls along. The wear rate between each link is greatly accelerated and can lead to premature failure. The chain should not wear out before the discs are worn down.

### ONLY POOR ADJUSTMENT CAUSES PREMATURE WEAR

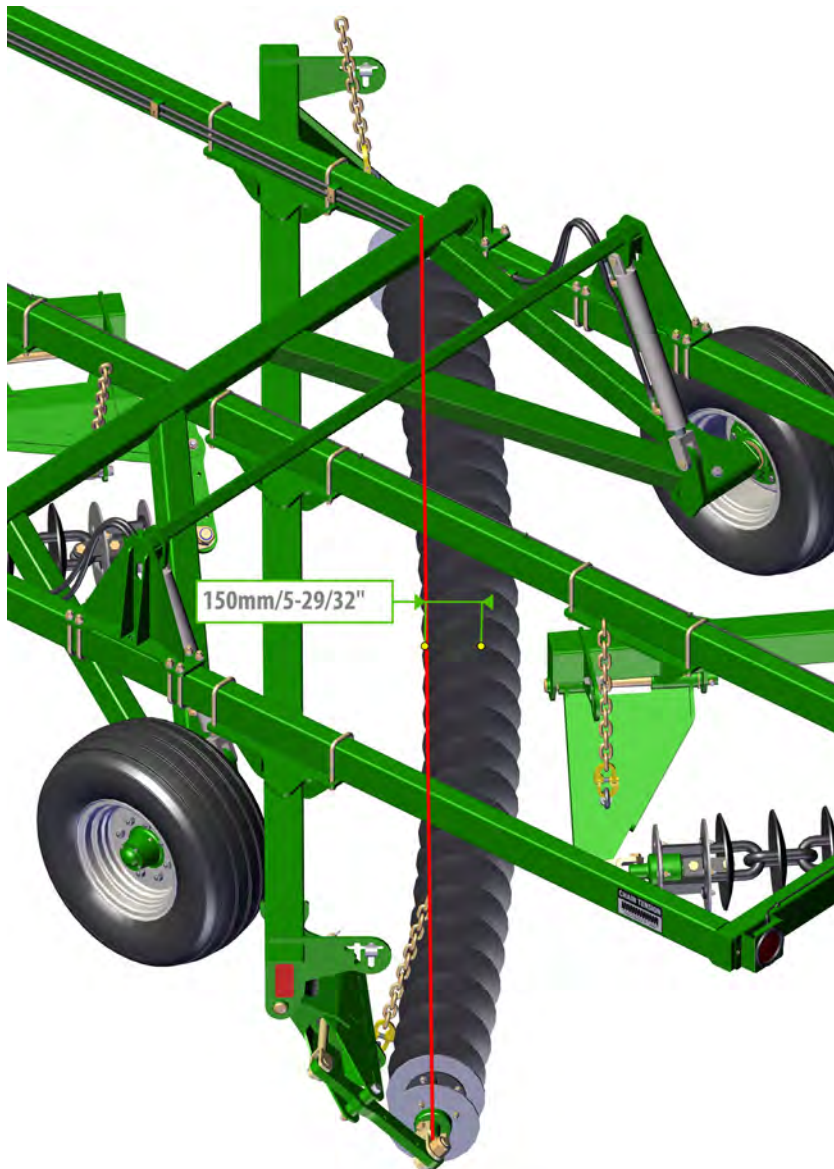

Indicator line shows acceptable curvature when operating.

## Chain Mount Arm Height Adjustment

1. Use tractor hydraulics to raise the module chain or chain mount plate that requires adjustment. Position a suitable block or stand to support the arm. Using the tractor hydraulics, lower the machine until the height adjusting chains are loose.
2. Remove spring retaining clip. Slide chain up to the top of the slot in lifting arm to pass the chain through the cross at top of plate.
3. Slide chain back down to the bottom when the desired position is reached. To achieve "one link" of adjustment, lift chain to the top of the slot, pass one link through the slot and rotate 90 degrees to allow the next link in the adjusting chain to lower into the same slot. To achieve "half link" of adjustment lift the chain to the top of the slot and slide chain horizontally and lower the same link into the second slot. This will raise or lower the chain mount plate by half a link depending on which slot the chain started in. Any excess chain can be fed back through the second slot.
4. Install retaining clip. Remove stand.

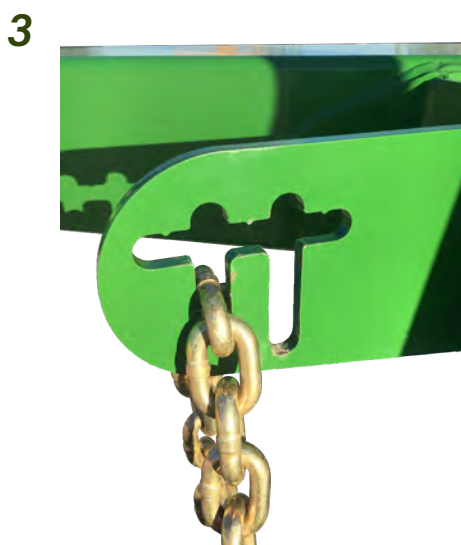
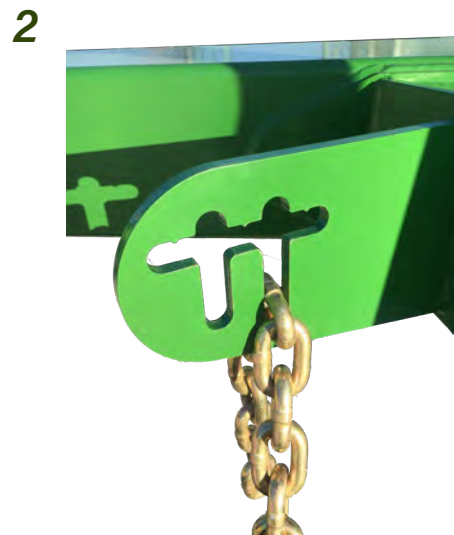
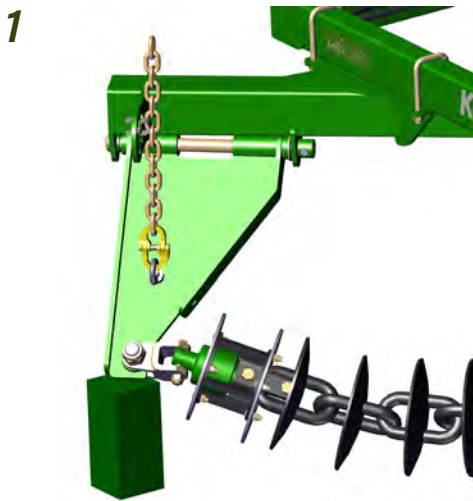

## Frame height adjustment

Set drawbar height using the cylinder depth stop plates on the drawbar cylinder.

Machine body must be parallel with the ground

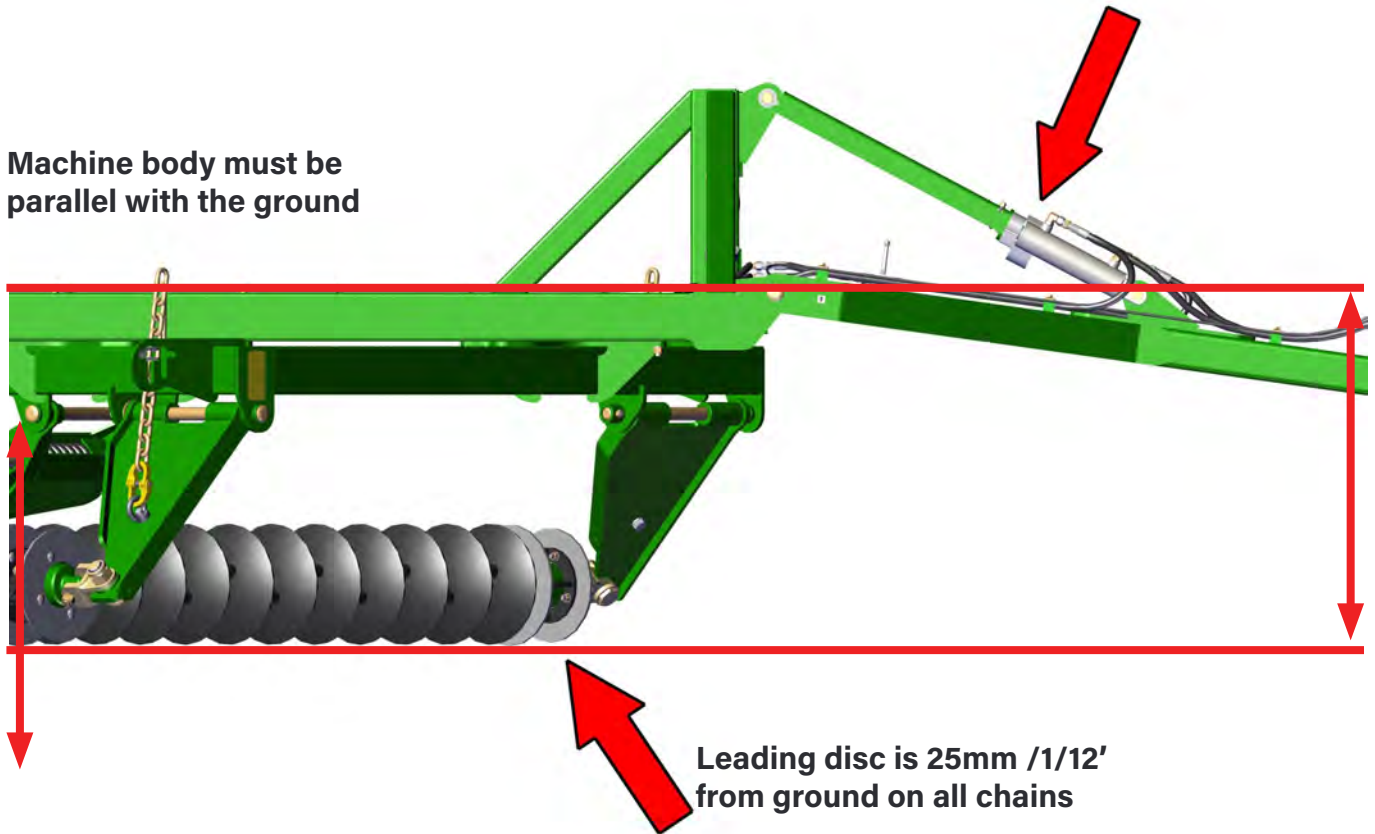

Check the length of the height adjusting chains on the two front chain mount plates. There should be no slack in the chain and about 25-51mm /1/12'-1/6' of gap between the ground and the bottom of the first disc machine near the centre line.



# Section 4 - Maintenance & Inspection

## Maintenance and inspection

### Good maintenance is your responsibility

- Before working on your machine, ensure all moving parts have stopped
- Always use a safety support and block the wheels
- Use extreme caution when making adjustments
- Replace shields and guards after servicing and before moving
- After servicing, make sure all tools, parts and service equipment are removed
- Where replacement parts are necessary for periodic maintenance and servicing, genuine factory parts must be used. Kelly Engineering will not guarantee the use of unapproved parts and other damages as a result of their use and will not be liable for injury or warranty if equipment has been altered in any way
- An appropriate fire extinguisher and first aid kit should be kept readily available while performing maintenance.



## Recommended Maintenance Checklist

Item to check	First operation	Daily	25 hourly	Pre-season
Hydraulic, hose and cylinders for damage and oil leaks				
Loose or missing fasteners/split pins				
Check bushes, pivot and cylinder pins for wear and replace as necessary				
Swivel unit fasteners				
Swivel unit - free and smooth rotation				
Swivel unit temperature: Average operating temperature is 55 °C, Failure is indicated at +80 °C				
Tires are inflated to correct pressure				
Wheel nuts are tightened at correct torque				
Check wheel bearings				
Check and tighten dust caps				
Disc roll pins/ locking bolts are in place				
Chain is tensioned correctly				
Lights are working correctly				
Warning signs are attached				
Grease wheel bearings				
Grease drawbar pivot				
Grease wheel lift bush				
We recommend that swivel units are covered for storage to prevent water penetration.				

## Chain Inspection

- There is a break-in period where the disc chain will wear in and become longer.
- More frequent adjustments will be necessary on a new machine.
- Over time, as the disc chain wears, it may be necessary to remove a link to maintain disc chain tension. This is the most important check and adjustment to ensure a long working life for the disc chain.

## Trouble Shooting

The majority of the Kelly Tillage System operating problems are due to incorrect adjustment. This trouble shooting section will help you by providing solutions to common problems.

Symptom	Problem	Solution
Chain Links wearing	Chain too loose. Chain loops back when working.	Refer to page 8 for setting correct chain tension
	Swivel set too close to ground.	Refer to page 10
Chain not rotating	Front chain swivels on machine too low  Foreign material fouling bearings	Refer to page 10
	Bearing failure in swivel unit	Refer to page 10
Uneven tread wear on transport wheels	Tire pressure too low  Excessive road speed	Inflate to correct pressure refer to table on page 16 Always travel at a safe speed. <b>NEVER EXCEED 25kph/16 mph.</b>
Chain not tensioning properly	Excessively worn chain  May need a link removed	Replace if required  Remove excess chain link
Operation leaves ridge behind machine  Operation leaves furrow behind machine	Chain swivels are too low	Refer to chain mount plate height adjustment on page 11



# Section 5 - Specifications

## Operating speeds

Recommended operating speeds in normal conditions with all chain types	
Operating / working speed	(6-8 mph) / (10-12 km/h)
Transporting / towing speed	(15 mph) / (25 km/h)

## Tire pressure

Tire size	Ply	KPA	PSI
31/13.5-15	12	206	30

## 12X specifications

Model	12X
Operating width	14' 9-1/2" / 4.51m
Transport width	14' 9-4/5" / 4.52m
Transport height	6' 3-22/25" / 1.93m
Transport length	30' 9-23/25" / 9.40m



## Bolt Torque Settings

Bolt Type	Wheel nut		U Bolt			Class 8.8 Bolt							Class 10.9 Bolt	Grade 8 Bolt
	Bolt Size	M12	M18	M12	M16	M20	M6	M8	M10	M12	M16	M20	M24	M20
Spanner	19	27	19	24	30	10	13	17	19	24	30	36	30	9/16"
Ft lb	65	221	21	53	104	7	16	32	57	140	273	472	389	849
Nm	88	300	29	72	141	9	22	44	77	190	370	640	528	1151

[1] When fitting a wheel & tire to a hub, tighten the wheel nuts in a star pattern to the correct tension. To achieve this, choose a wheel nut & tighten, then proceed to the opposite side of the hub to the next wheel nut & tighten & so on until all wheel nuts are tight. Then repeat the procedure to check that all nuts are tight. Do not use impact tools to tighten wheel nuts. For a guide to the correct tension of the wheel nuts please use the appropriate tension for your size wheel nuts from the Bolt Torque Settings table.

Torque values are for dry threads and surfaces however it is permissible to apply a small amount of anti-corrosive oil to the threads.

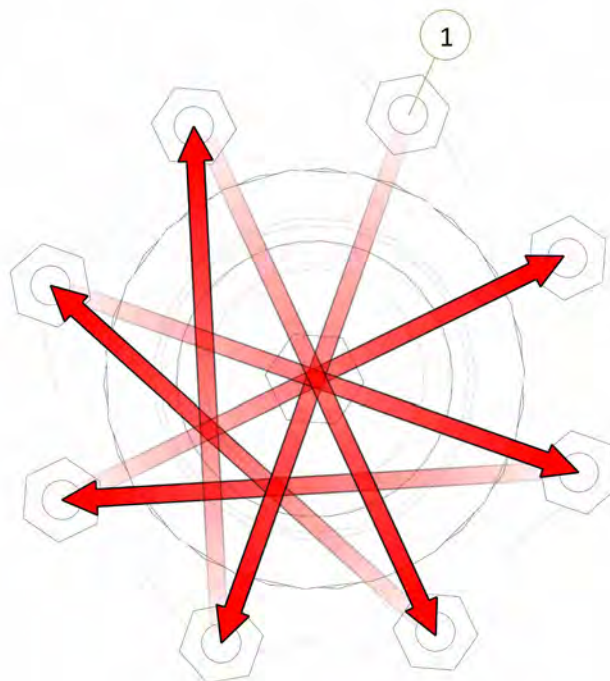

## Disc Chain Lengths and Quantities

12X Model	Length	CL1/W36	CL1	W36	SD49	K4
Front Left	7' 1-39/100" / 2.169m	CL1 - 15	13	13	17	14
Centre	15' 10-43/100" / 4.583m	CL1 - 15 W36 - 14	28	27	37	29
Rear Right	8' 1-12/25" / 2.476m	W36 - 15	15	14	20	16

For correct chain tension, chain links may need to be removed from the end of the chain as follows:

CL1 Disc Chain - unhook disc chain link/s from end of the disc chain

Spiked Disc Chain - cut a disc chain link from the end of the disc chain

W36 Disc Chain - cut a disc chain link from the end of the disc chain

K4 Disc Chain - unhook disc chain link/s from end of the disc chain

Scan the following QR code to open the removing a welded disc chain video.



FRONT CHAINSET

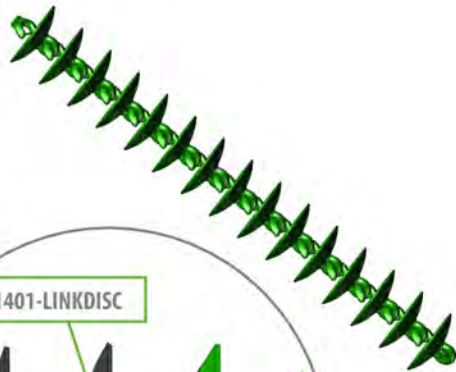

CL1

CENTRE CHAINSET

W36



REAR CHAINSET





# Section 6 - Pre-Delivery Checklist

Check Item:	Checked by Initial
Hydraulic hoses are routed through holders and fitted to cylinders with no leaks	
All bolts and nuts are tightened to the correct torque values and marked.	
All split pins are inserted and split	
All safety signs and decals are in the correct locations as per the Assembly/ Operator's manual	
All safety lights are in the correct locations and working	
All tires are fitted correctly and inflated to correct pressure	
All wheel nuts are tightened to the correct torque and marked	
Swivel Units are correctly orientated	
Grease all marked locations	
Disc roll pins/locking bolts are installed in the discs (CL1, CL2 and K4 only)	
Check the chain tension as per Operators manual	
Machine is registered for warranty	
Customer has been shown the website and how to access parts information	
Operator's manual has been provided with the machine	

Completed Pre-Delivery Checklist to be returned to [warranty@kellytillage.com](mailto:warranty@kellytillage.com) within 7 days of delivery to the customer.

<b>Name:</b>	
<b>Signature:</b>	
<b>Date:</b>	



# Notes

A series of horizontal lines for taking notes, starting from the top of the white content area and extending to the bottom.





Phone +61 8 8667 2253  
Email [sales@kellytillage.com](mailto:sales@kellytillage.com)  
[kellytillage.com](http://kellytillage.com)

**Booleroo (Head Office)**  
684 Kelly Road,  
Booleroo Centre SA 5482

**Adelaide Office**  
28 Greenhill Road,  
Wayville SA 5034

