



Better Tillage. Better Tomorrow.

Assembly Manual

KELLY TILLAGE SYSTEM 4614

KEASM-P-01012023

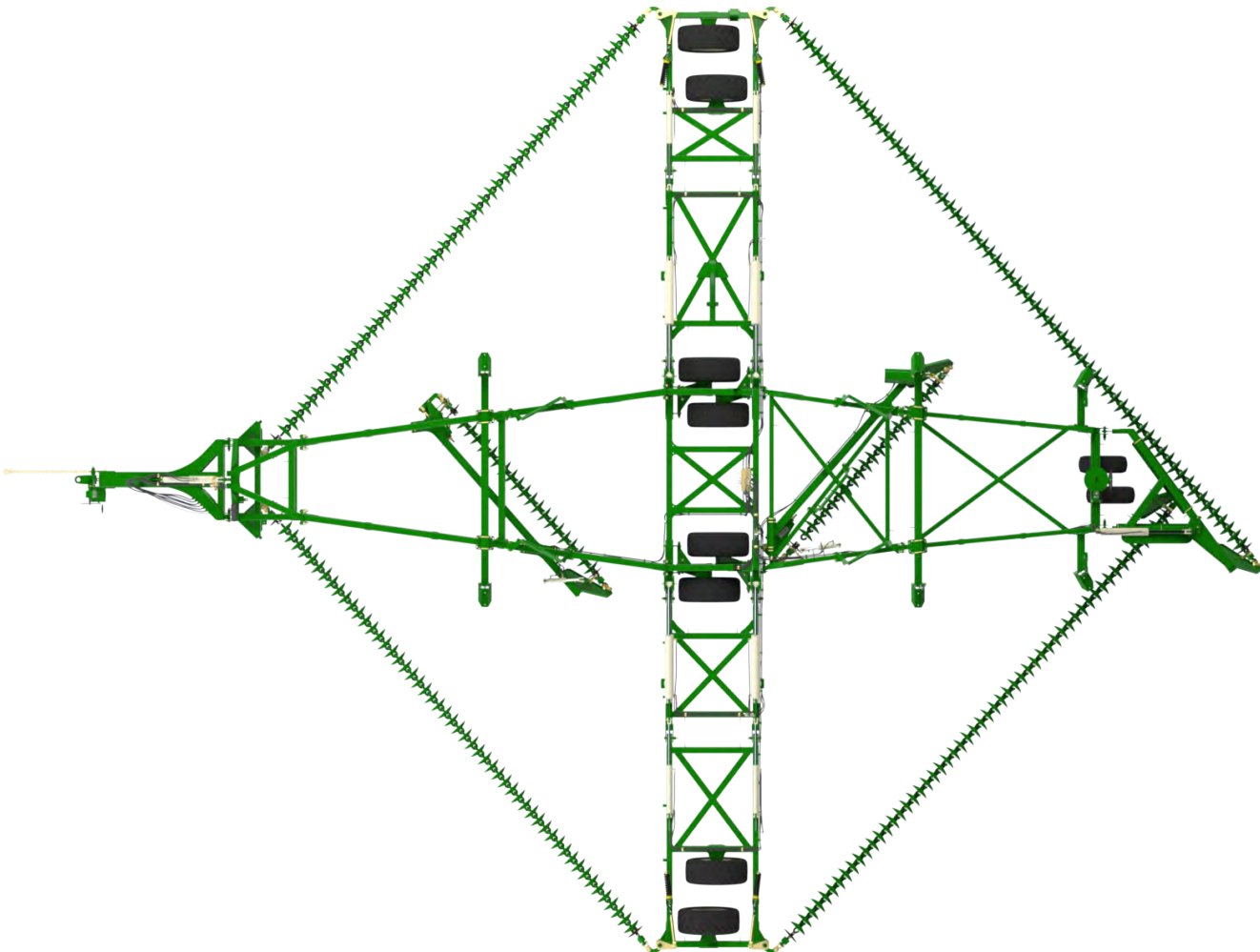

SERIAL NUMBER:



Phone +61 8 8667 2253
Email sales@kellytillage.com
kellytillage.com

Booleroo (Head Office)
684 Kelly Road,
Booleroo Centre SA 5482

Adelaide Office
28 Greenhill Road,
Wayville SA 5034





Thank you for choosing a KELLY product.

We trust that you find the following manual clear and easy to follow. If you should require additional customer support or assistance, please do not hesitate to contact us.

Spare parts can be purchased, as required, through your local dealer or by contacting KELLY directly.

The KELLY team values your feedback. Should you have any difficulties that you wish to raise, suggestions for improvement or modifications that you feel would enhance our products we look forward to hearing from you.

Contact Us

Australia

Booleroo (Head Office)

684 Kelly Road,
Booleroo Centre SA 5482

+61 8 8667 2253

Monday - Friday
8am - 4pm ACDT

Adelaide Office

28 Greenhill Road,
Wayville SA 5034

+61 8 8667 2253

Monday - Friday
8am - 4pm ACDT

Global Locations

Eastern Canada

Leading Edge Equipment
www.leadingedgeequipment.ca

1-519-421-3223

Monday - Friday
8am - 4pm EST

Western Canada

Adair Sales & Marketing Co Inc
www.adairreps.com

1-306-773-0996

Monday - Friday
8am - 5pm CST

United States

Hood & Company

+1 417-865-2100

Monday - Friday
8am - 4pm CST

Europe

kellytillage.com

+61 8 8667 2253

Monday - Friday
8am - 4pm ACDT

Argentina

Giorgi Sa Maquinarias Agrícolas
www.giorgi.com.ar

+54 3464 493512

Monday - Friday
8am - 5pm ART

South Africa

Desmond Whitfield CC

+27 82 567 8245

Monday - Friday
8am - 4pm SAST

Contents

Section 1 - Unpacking	5
Section 2 - Assembly	6
Section 3 - Decal Application	134
Section 4 - Light Kit	155
Section 5 - Chain Assembly	165
Section 6 - Specifications	173
Section 7 - Operation	178

Legend



This symbol indicates which bag the relevant fasteners are in.



This symbol indicates which bag the relevant hydraulics are in.

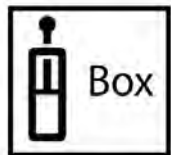

This symbol indicates the hydraulics are in a box.



This symbol indicates which way the machine is travelling.

Bolt Torque Settings

Bolt Type	Wheel nut					U Bolt 4.6				Grade 8.8 Bolt						Grade 10.9 Bolt		Grade 8 Bolt	
Bolt Size	M12	M18	M20	1/2"	9/16"	M10	M12	M16	M20	M6	M8	M10	M12	M16	M20	M24	M20	M24	1" UNF
Spanner	19	27	30	19	22	17	19	24	30	10	13	17	19	24	30	36	30	36	36
Ft lb	69	221	265	102	142	12	21	53	104	7	16	32	57	140	273	472	389	660	931
Nm	94	300	360	138	192	17	29	72	141	9	22	44	77	190	370	640	528	895	1262

[1] When fitting a wheel & tire to a hub, tighten the wheel nuts in a star pattern to the correct tension. To achieve this choose a wheel nut & tighten, then proceed to the opposite side of the hub to the next wheel nut & tighten & so on until all wheel nuts are tight. Then repeat the procedure to check that all nuts are tight. Do not use impact tools to tighten wheel nuts. For a guide to the correct tension of the wheel nuts please use the appropriate tension for your size wheel nuts from the Bolt Torque Settings table.

Torque values are for dry threads and surfaces however it is permissible to apply a small amount of anti corrosive oil to the threads.

Verification and recording of the prescribed torque settings in the table above is the responsibility of the assembler and it shall be documented in accordance with their approved Quality Assurance system

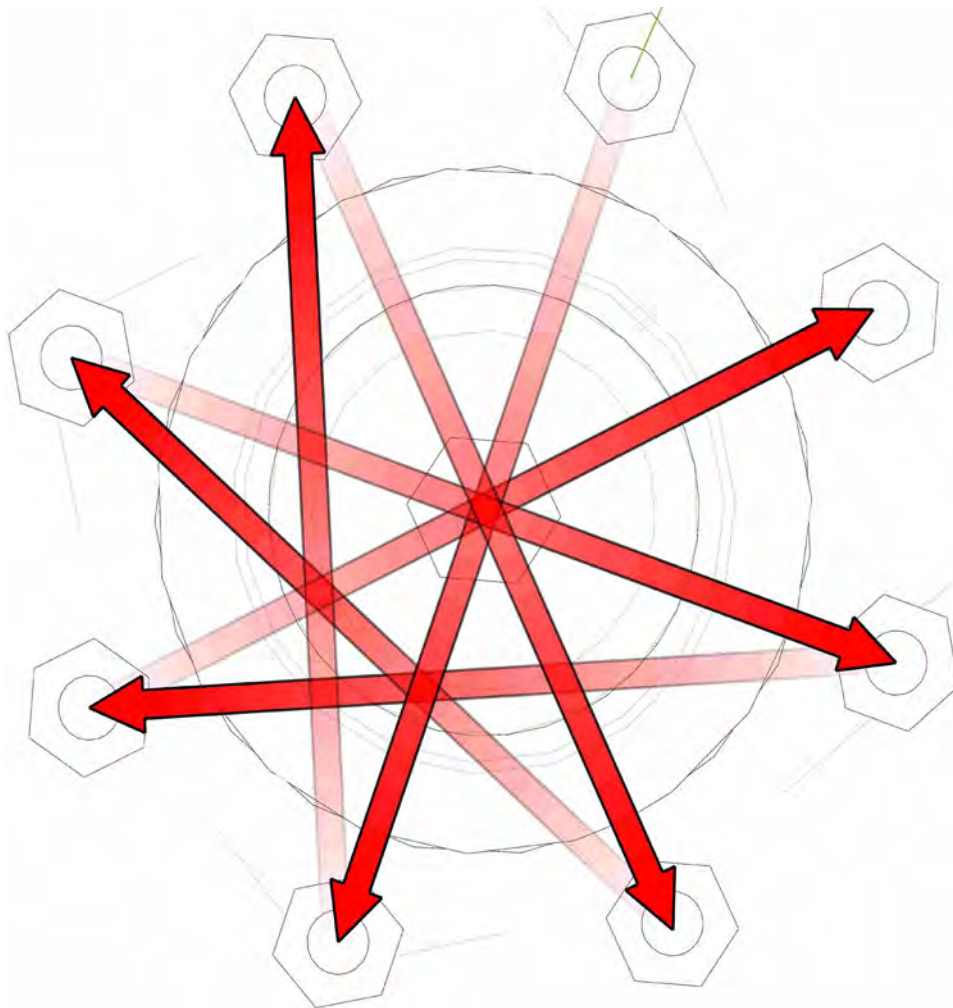



Section 1 - Unpacking



CAUTION

Before cutting straps attach slings or chains and take the weight of the frames to avoid them slipping or falling and causing injury.



CAUTION

Wear eye and hand protection when cutting straps. Sharp edges are exposed as straps separate and may cause injury.



CAUTION

To avoid falling or moving components, before cutting straps attach slings or chains to individual pieces and only cut the straps holding the piece to be lifted.

- Remove boxes from rear of container one at a time using a forklift truck. Each box weighs approximately 5512 lbs (2500 kg)
- Cut straps holding bundles and separate parts and place in assembly area
- Once all parts have been identified, the machine is ready for assembly
- Identify parts for each machine by serial no. or description and separate. Open parts box and check that all parts are accounted for against checklist
- Read assembly instructions before proceeding.

Dealer assembly begins at page 58.



Section 2 - Assembly

Fastener Bag Locations

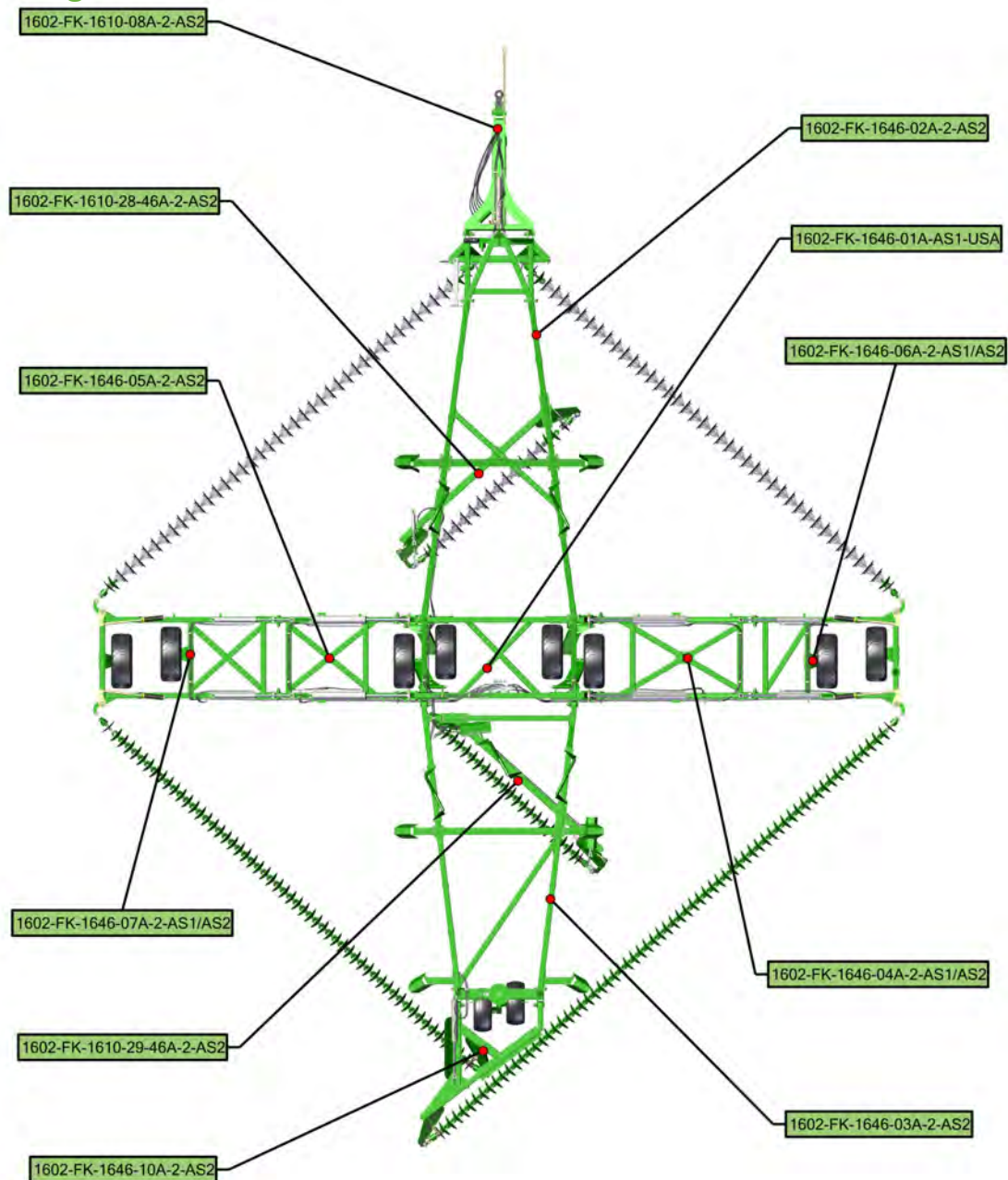

Item No.	Description	Number	Qty
1	46' Centre Frame	1646-01-2	1
2	LH Walking Axle Arm	1610-40	2
3	RH Walking Axle Arm	1610-41	2
4	1-1/2 ID x 2" DU Bush	0113-24DU32	8



Please note bushes are factory inserted

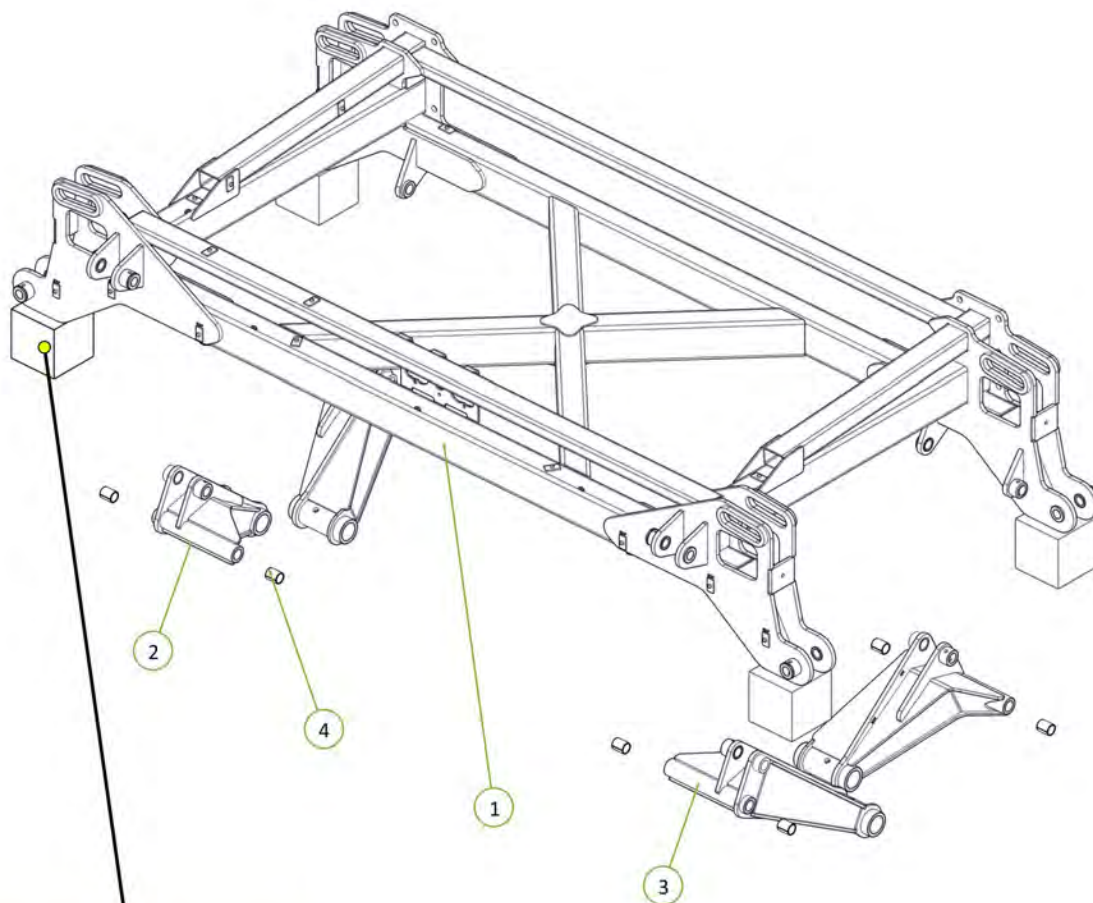

Support frame with blocks or stands during initial assembly

Item No.	Description	Number	Qty
1	Walking Axle Pivot Pin	1601-P38-525	4
2	Washer High Tensile 1 3/8"	0232-HT13-8	8
3	M12 x 90 Class 8.8 ZP Bolt	0211-1290	4
4	Nyloc Nut M12	0221-NYL12	4
5	Cotter Pin M13 x 63	0261-PINC1363	4

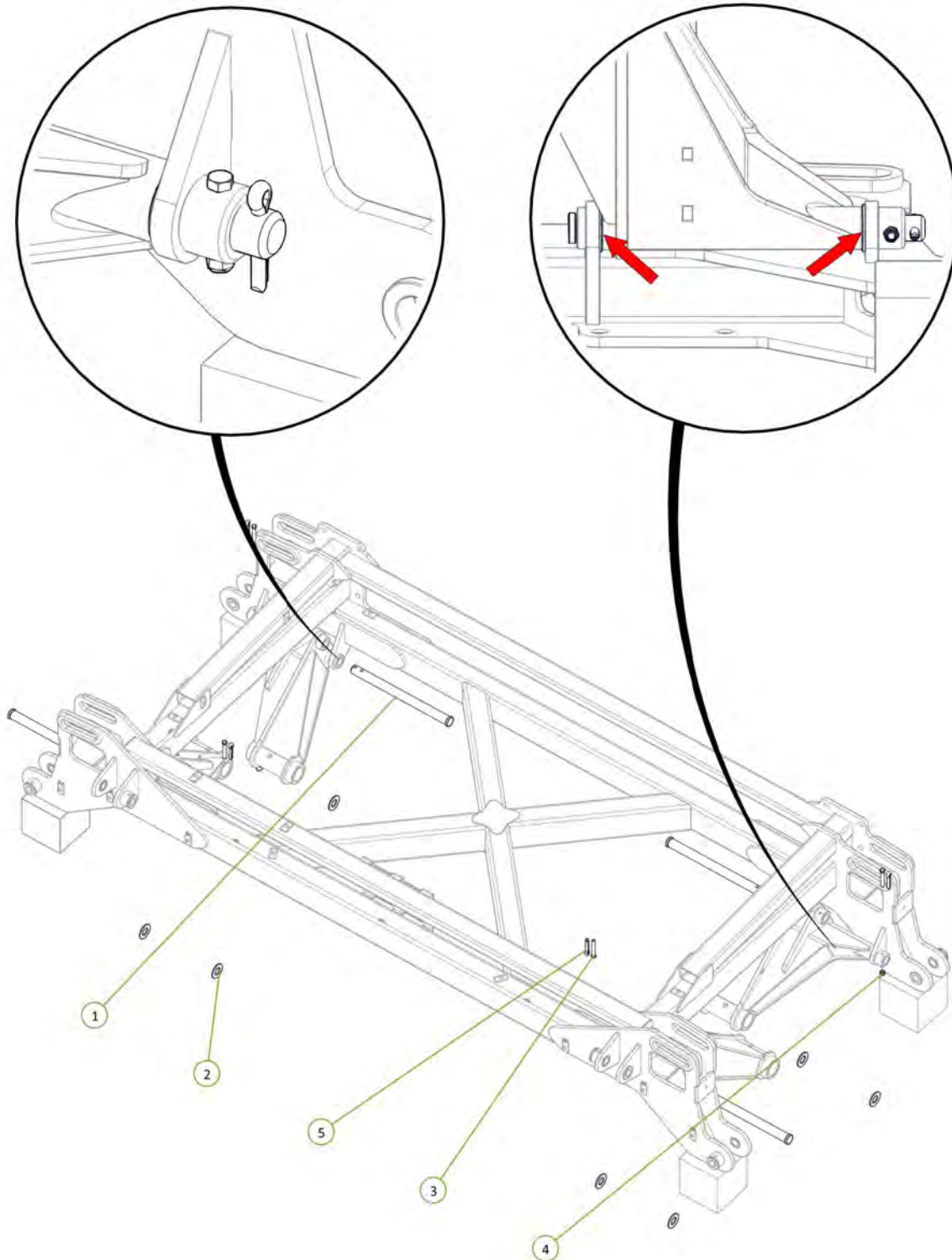

Item No.	Description	Number	Qty
1	2.75"R C/W 6 tonne 8 on 8" PCD Complete Assembly inc GS	0733-LG6080067	4
2	M20 x 120 grade 8.8 ZP Bolt	0211-20120	4
3	Nyloc Nut M20	0221-NYL20	4

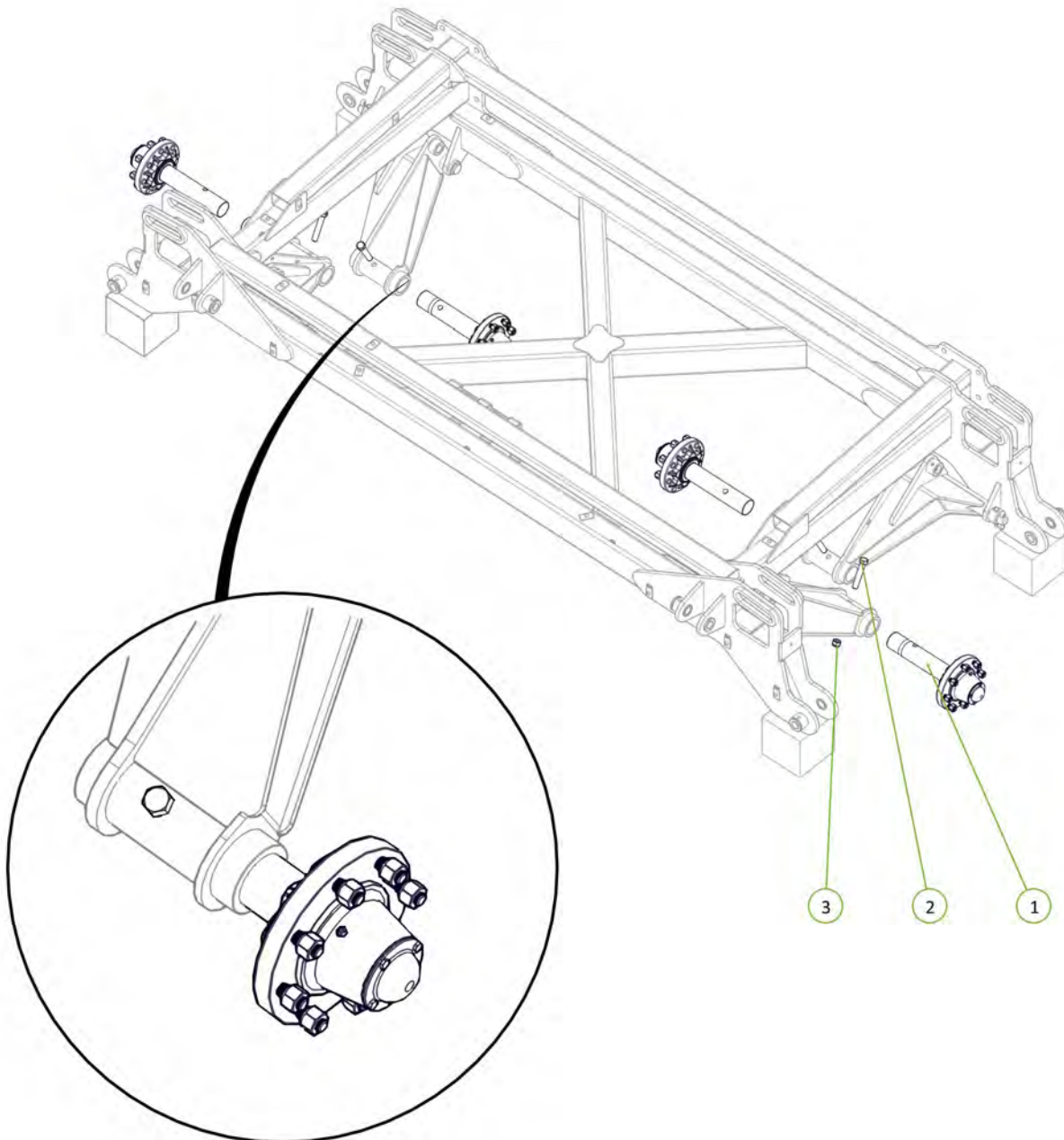

Item No.	Description	Number	Qty
1	Wing Folding Buffer	1201-12	4
2	M16 x 55 grade 8.8 zp Bolt	0211-1655	4
3	Washer Flat M16	0231-F16	4
4	Nyloc Nut M16	0221-NYL16	4

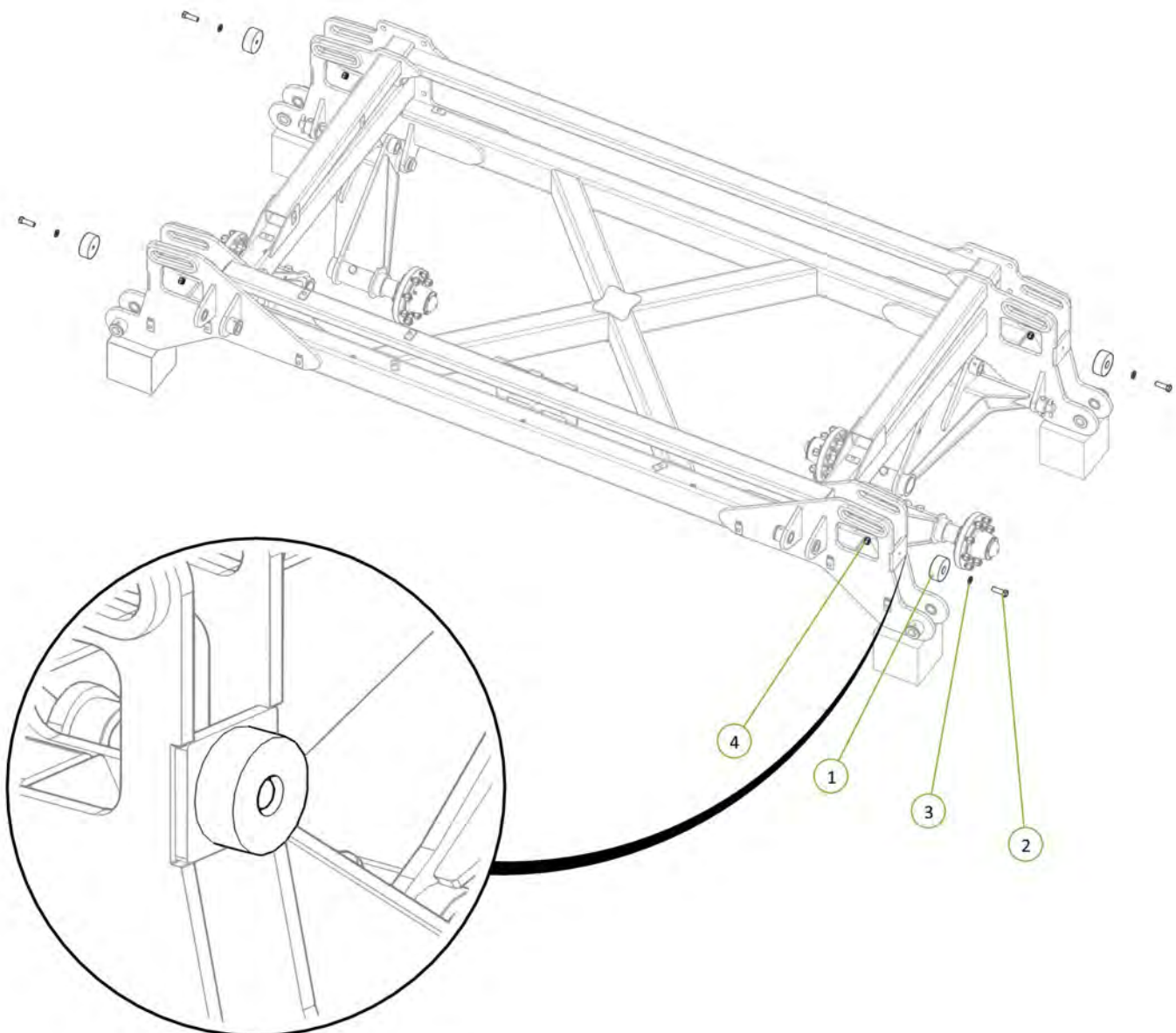

Item No.	Description	Number	Qty
1	46' RH Inner Wing Frame	1646-04-2	1
2	35 ID x 30mm DU Bush	0113-MB3530DU	4
3	PCH Wing Pivot Pin	0801-10-08-235	2
4	Nyloc Nut M12	0221-NYL12	2
5	Cotter Pin M13 x 63	0261-PINC1363	2
6	M12 x 90 Class 8.8 ZP Bolt	0211-1290	2

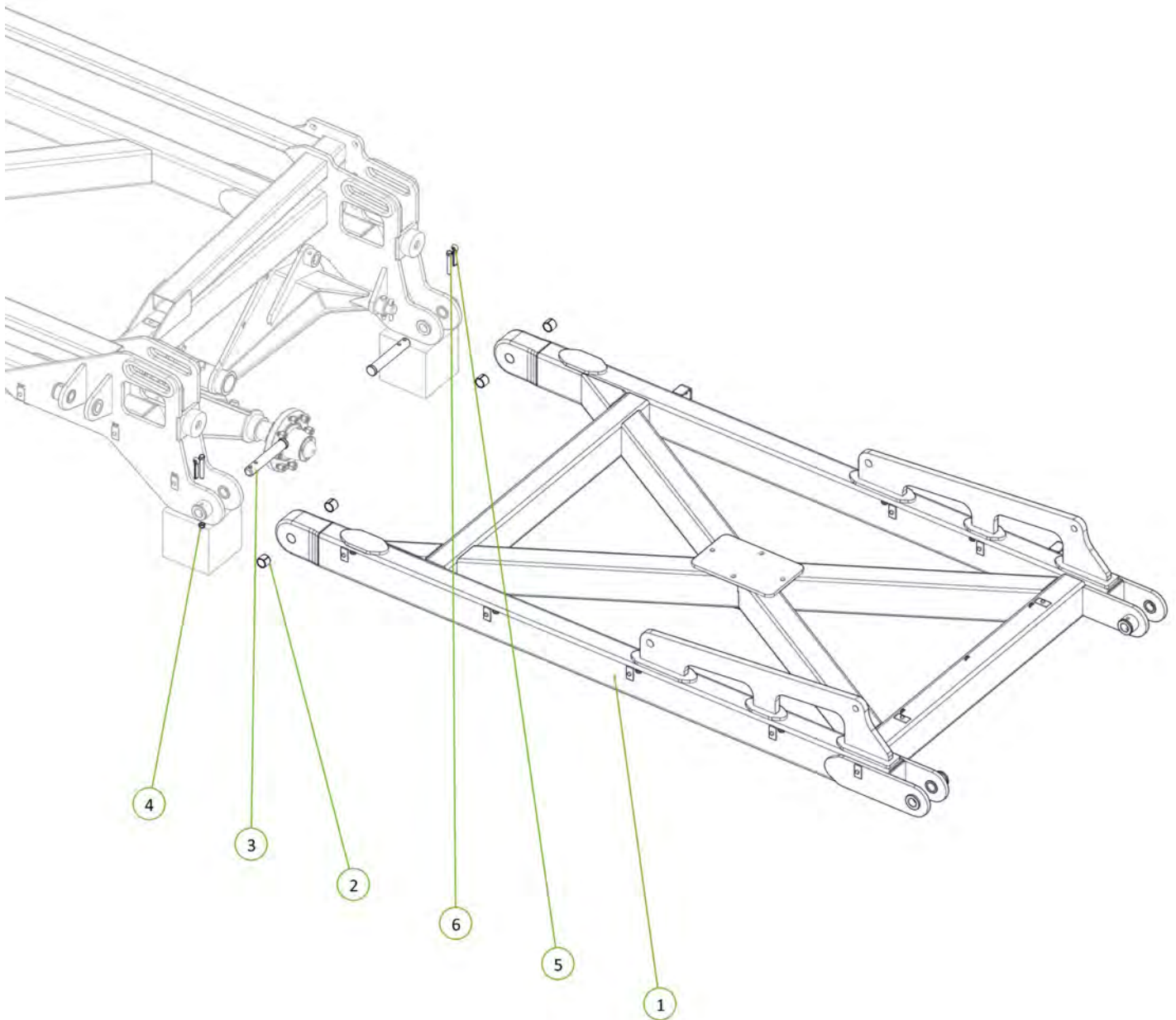

Item No.	Description	Number	Qty
1	46' Inner Wing Post	1646-04P-2	1
2	M16 x 50 Grade 8.8 ZP Bolt	0211-1650	4
3	Nyloc Nut M16	0221-NYL16	4
4	Washer Flat M16	0231-F16	8

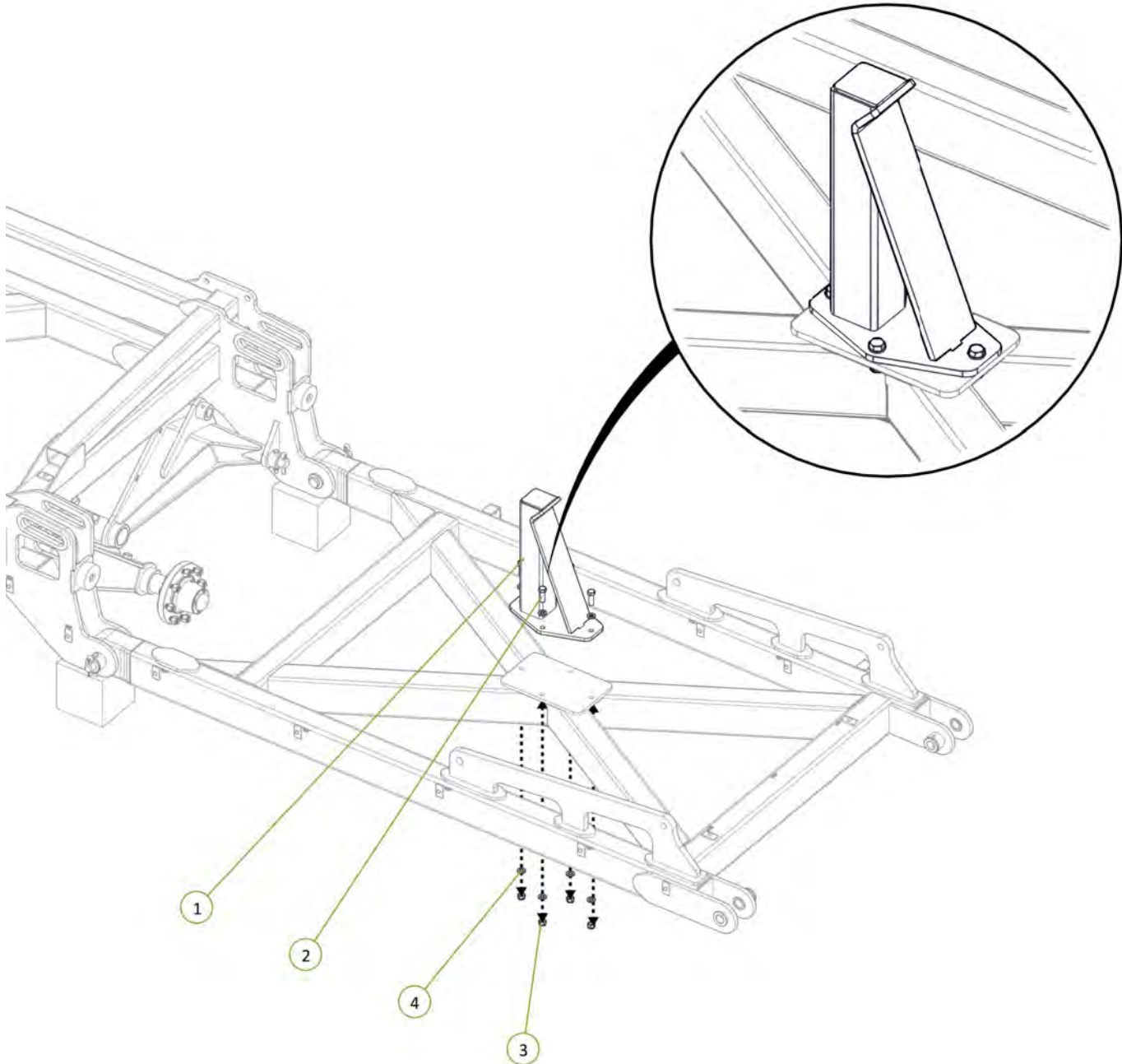

Item No.	Description	Number	Qty
1	46' RH Outer Wing Frame	1646-06-2	1
2	35 ID x 30mm DU Bush	0113-MB3530DU	4
3	PCH Wing Pivot Pin	0801-10-08-235	2
4	Nyloc Nut M12	0221-NYL12	2
5	Cotter Pin M13 x 63	0261-PINC1363	2
6	M12 x 90 Class 8.8 ZP Bolt	0211-1290	2

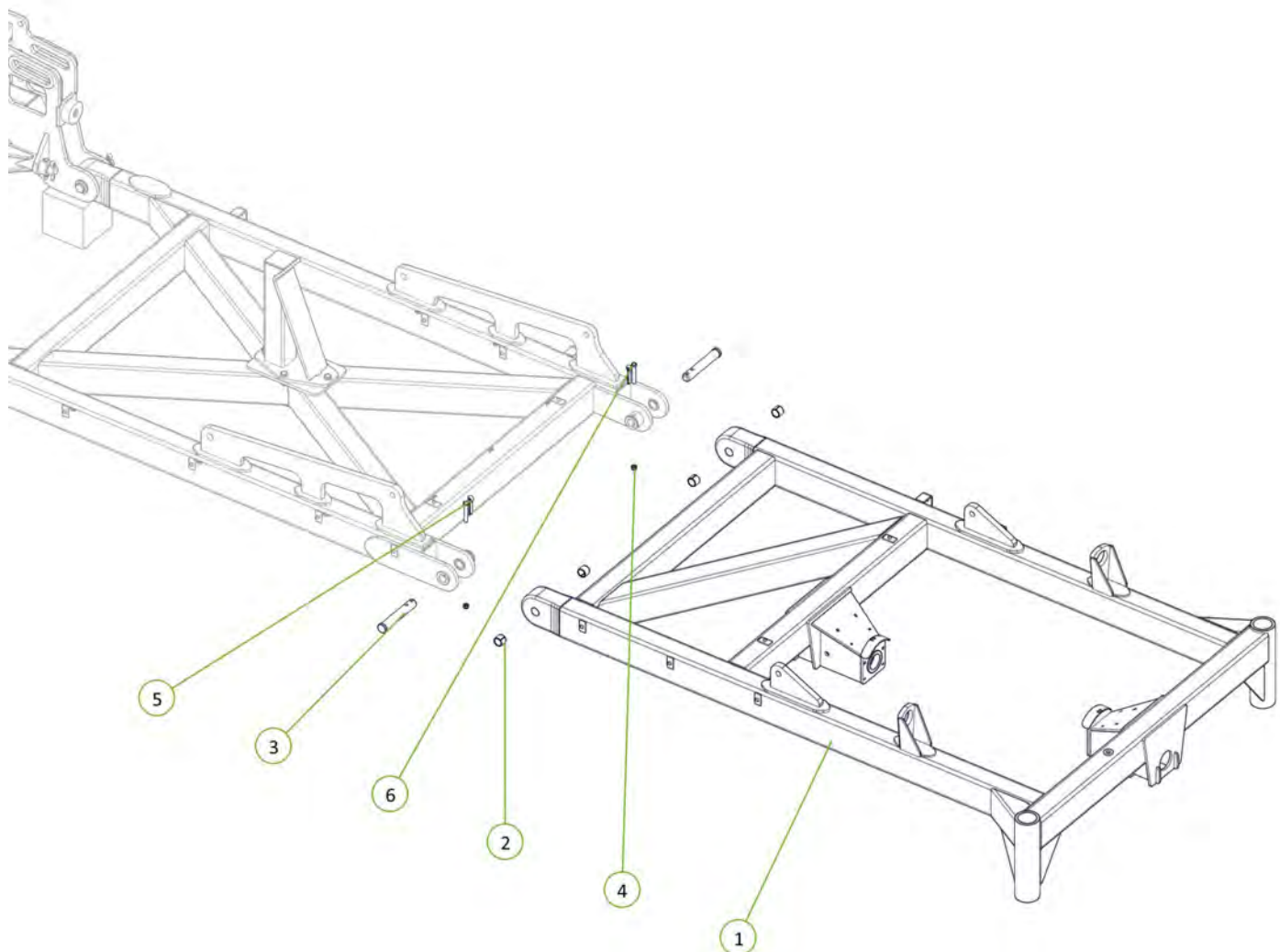

Item No.	Description	Number	Qty
1	46' Outer Wing Post	1646-06P-2	1
2	U-Bolt M16 x 190 Deep x 106 Wide	0271-16190106U	2
3	Nyloc Nut M16	0221-NYL16	4
4	Washer Flat M16	0231-F16	4

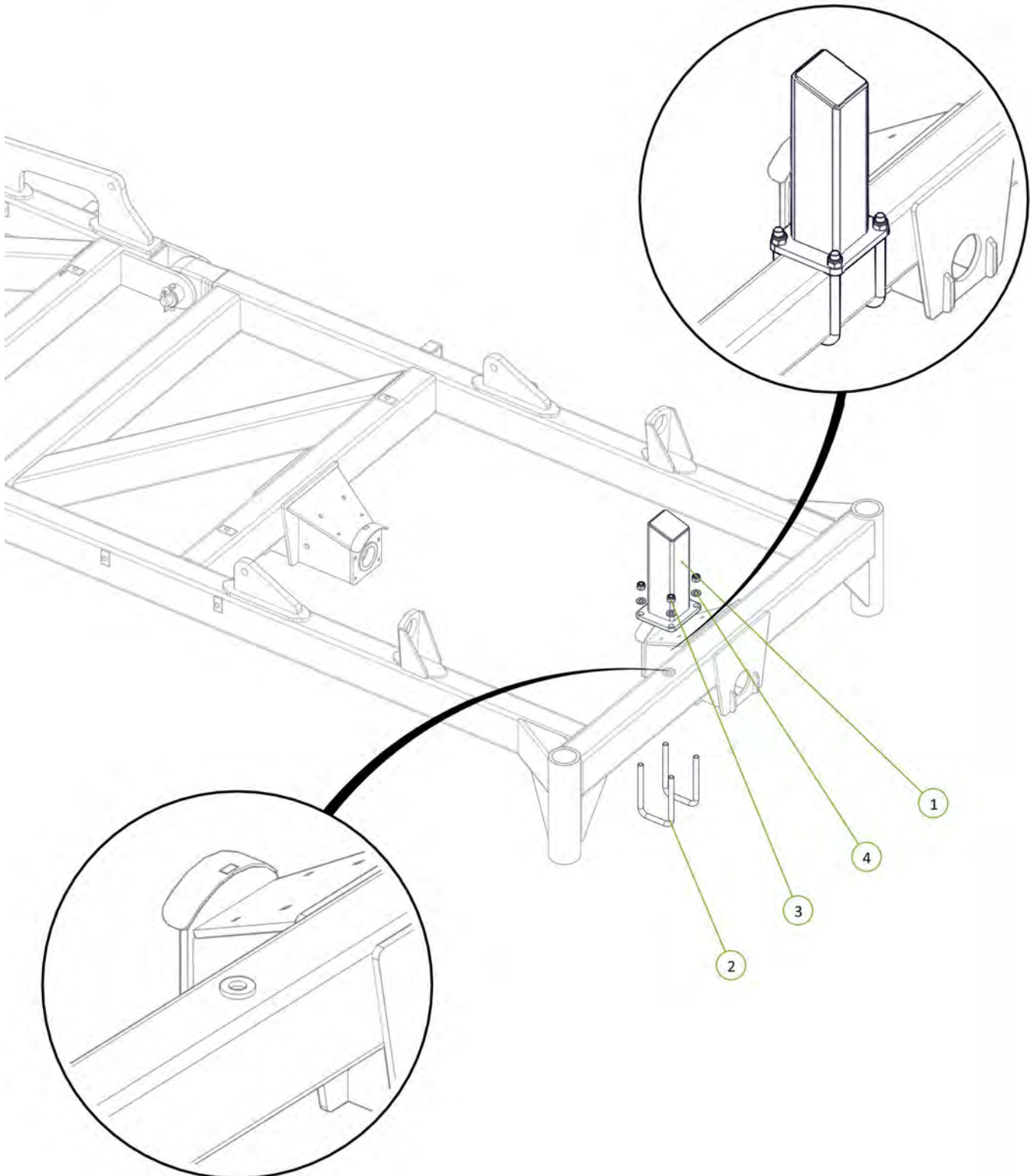

Item No.	Description	Number	Qty
1	2.75"R C/W 6 tonne 8 on 8" PCD Complete Assembly inc GS	0733-LG6080067	2
2	M20 x 170 grade 8.8 ZP Bolt	0211-20170	2
3	Nyloc Nut M20	0221-NYL20	2
4	Washer Flat M20	0231-F20	4

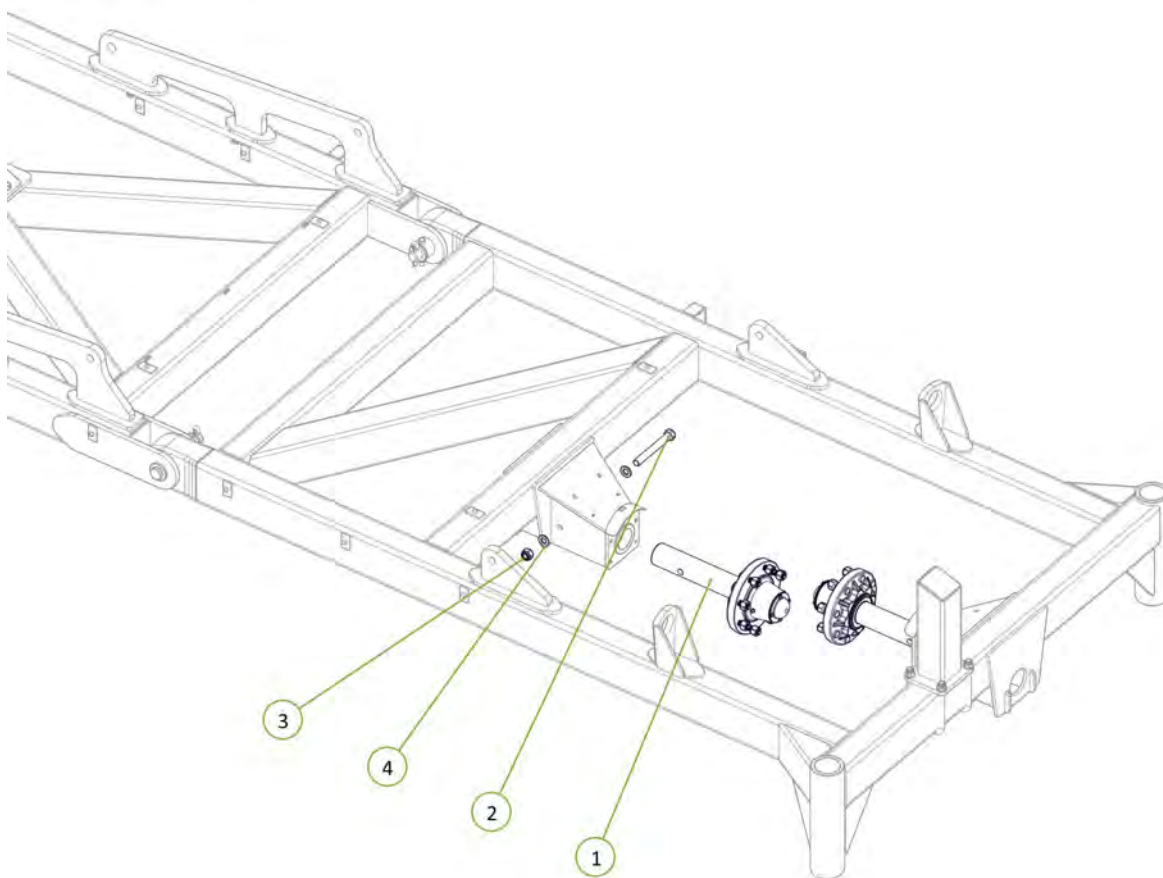
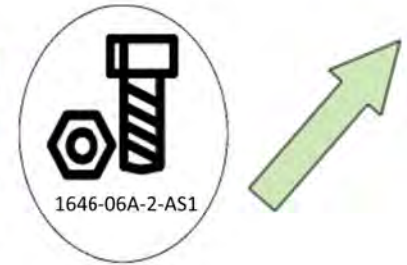

Dual outer wing wheel option shown

Item No.	Description	Number	Qty
1	46' LH Inner Wing Frame	1646-05-2	1
2	35 ID x 30mm DU Bush	0113-MB3530DU	8
3	PCH Wing Pivot Pin	0801-10-08-235	2
4	Nyloc Nut M12	0221-NYL12	2
5	Cotter Pin M13 x 63	0261-PINC1363	2
6	M12 x 90 Class 8.8 ZP Bolt	0211-1290	2

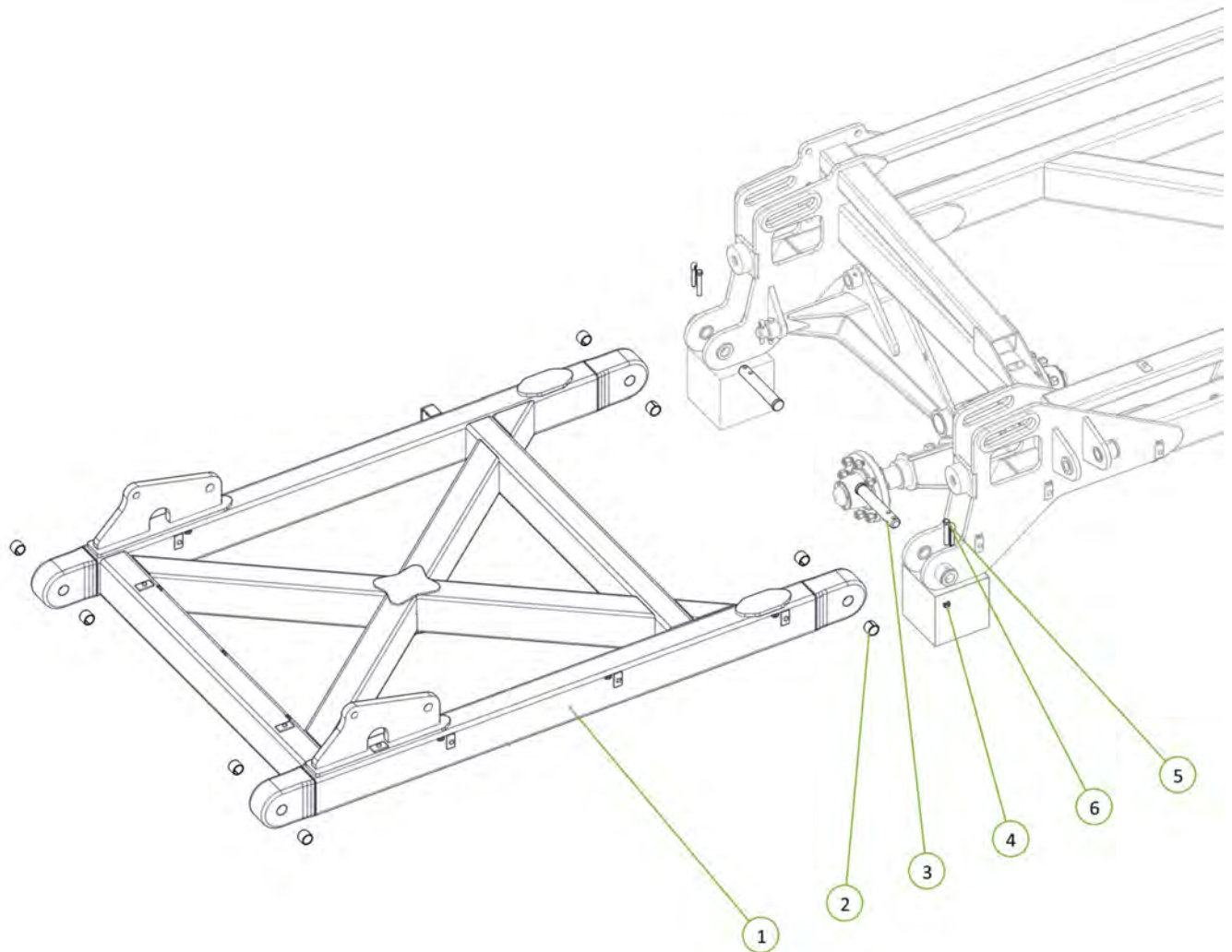

Item No.	Description	Number	Qty
1	46' LH Outer Wing Frame	1646-07-2	1
2	PCH Wing Pivot Pin	0801-10-08-235	2
3	M12 x 90 Class 8.8 ZP Bolt	0211-1290	2
4	Nyloc Nut M12	0221-NYL12	2
5	Cotter Pin M13 x 63	0261-PINC1363	2

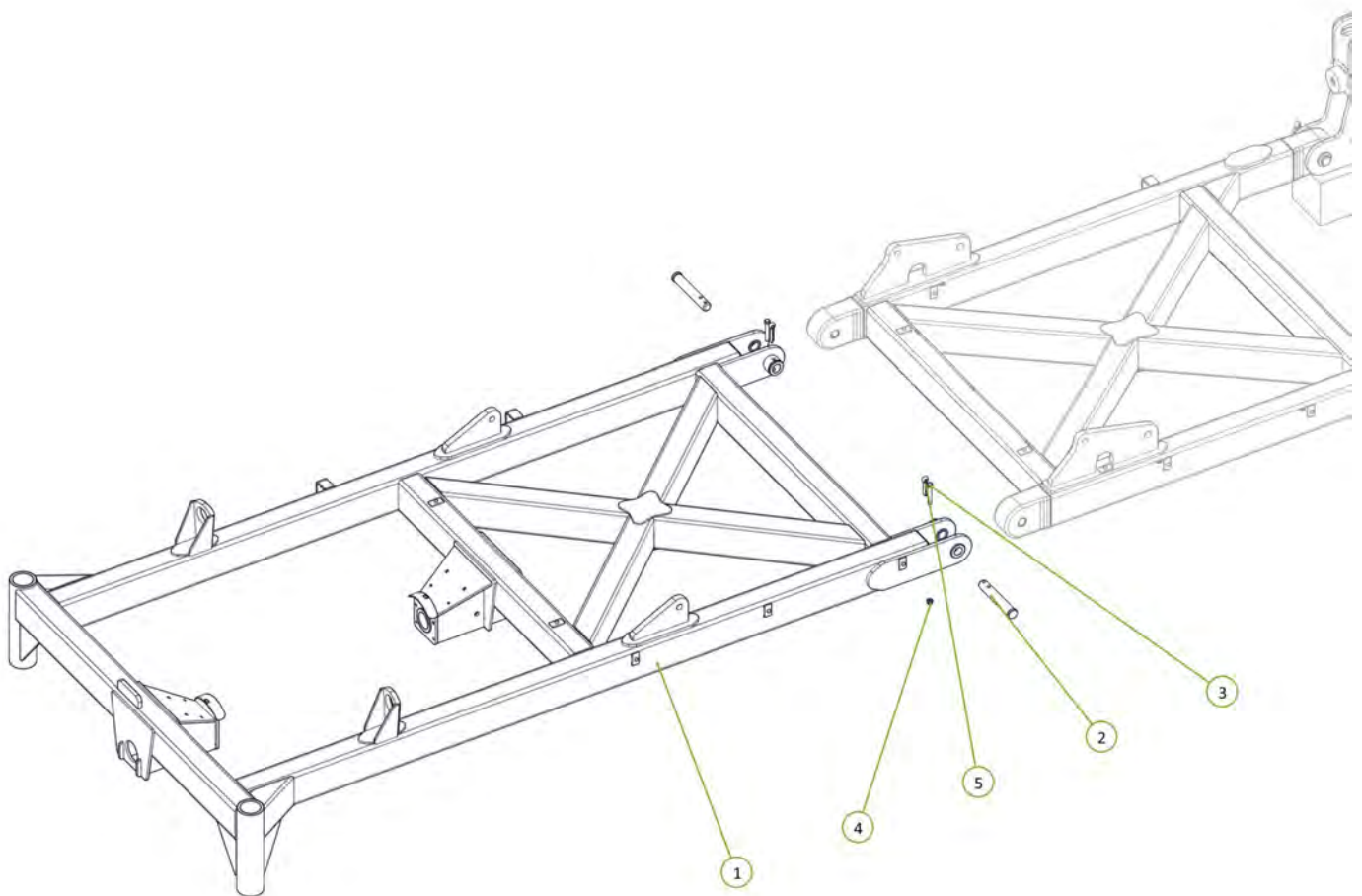

Item No.	Description	Number	Qty
1	2.75"R C/W 6 tonne 8 on 8" PCD Complete Assembly inc GS	0733-LG6080067	2
2	M20 x 170 grade 8.8 ZP Bolt	0211-20170	2
3	Nyloc Nut M20	0221-NYL20	2
4	Washer Flat M20	0231-F20	4

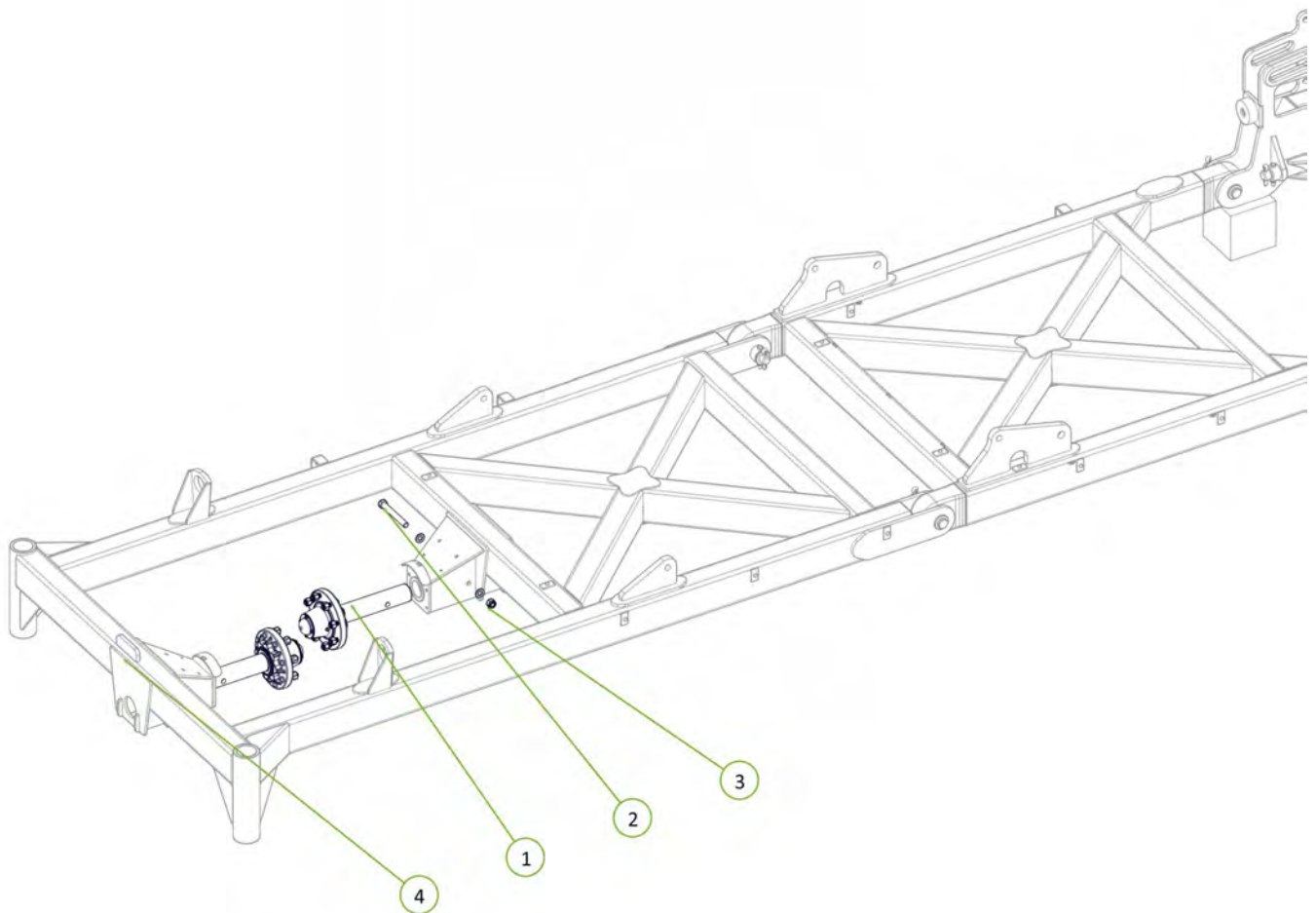

Item No.	Description	Number	Qty
1	Dual Circuit 3 Stage Sequence Manifold V12.5	0802-692196	1
2	M10 x 30 grade 8.8 ZP Bolt	0211-1030	6
3	Washer Spring M10	0231-S10	6
4	Washer Flat M10	0231-F10	6

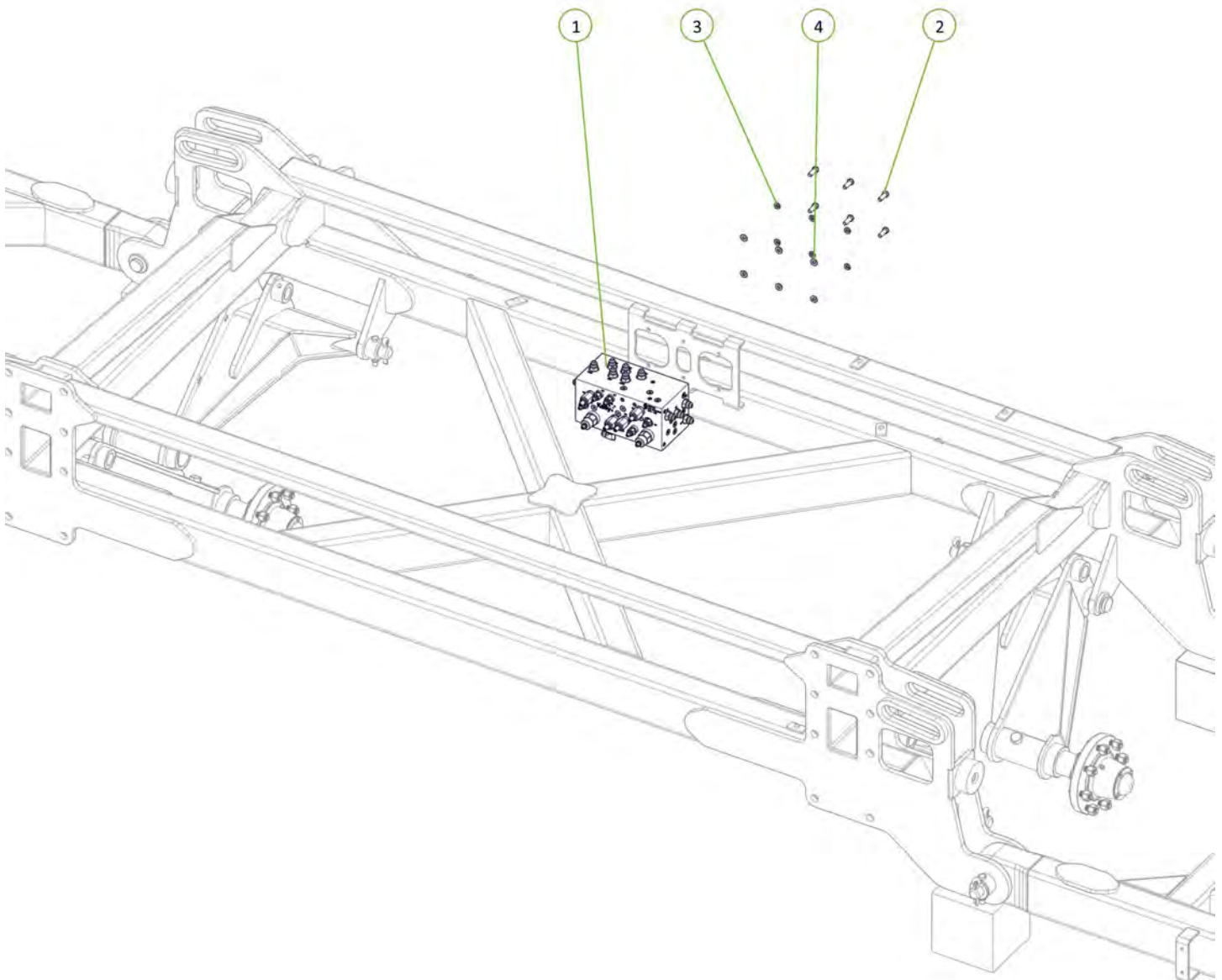

Item No.	Description	Number	Qty
1	3" Bore x 24" Stroke 1.5" Rod Hydraulic Cylinder Side Port	0311-324STSP	2

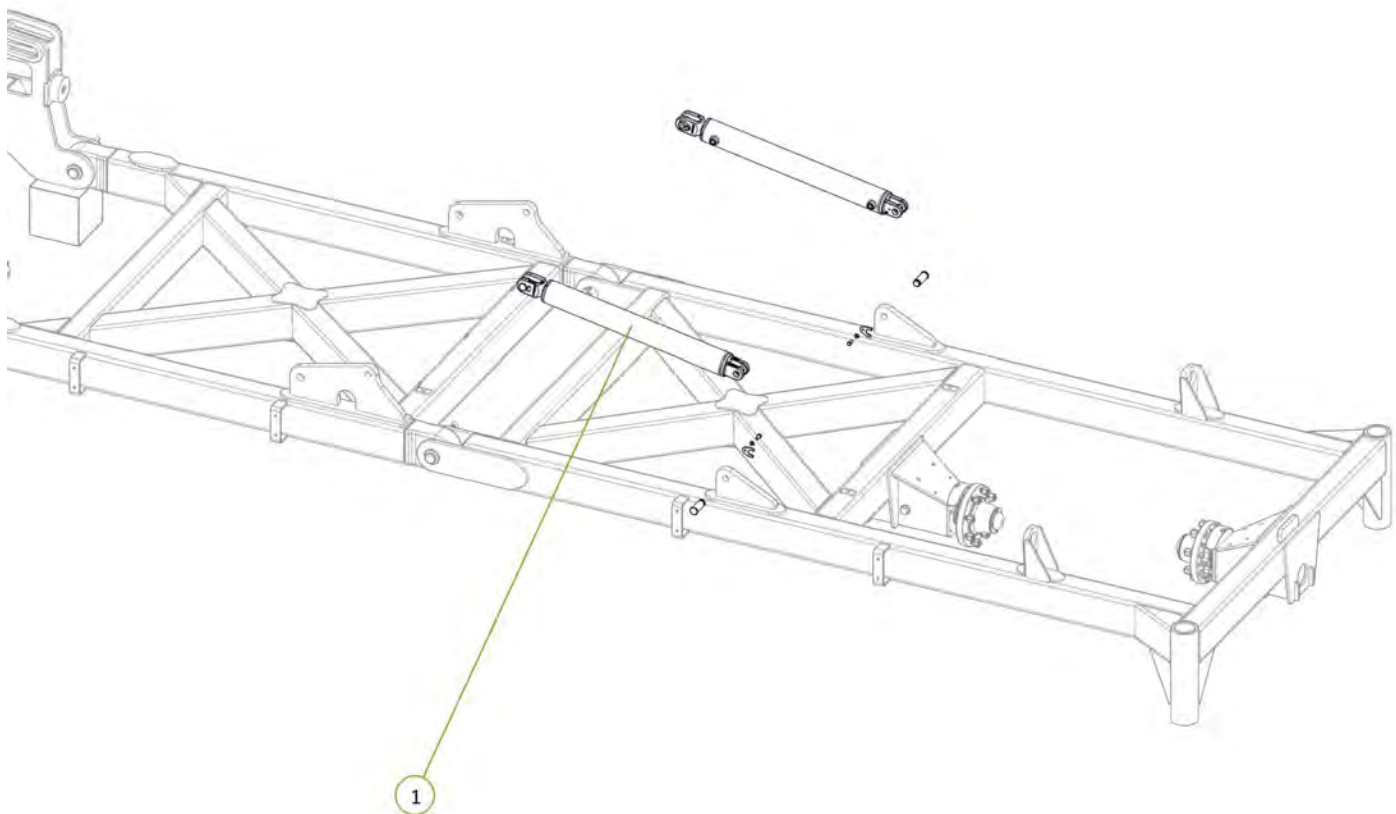
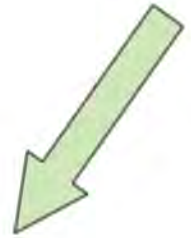

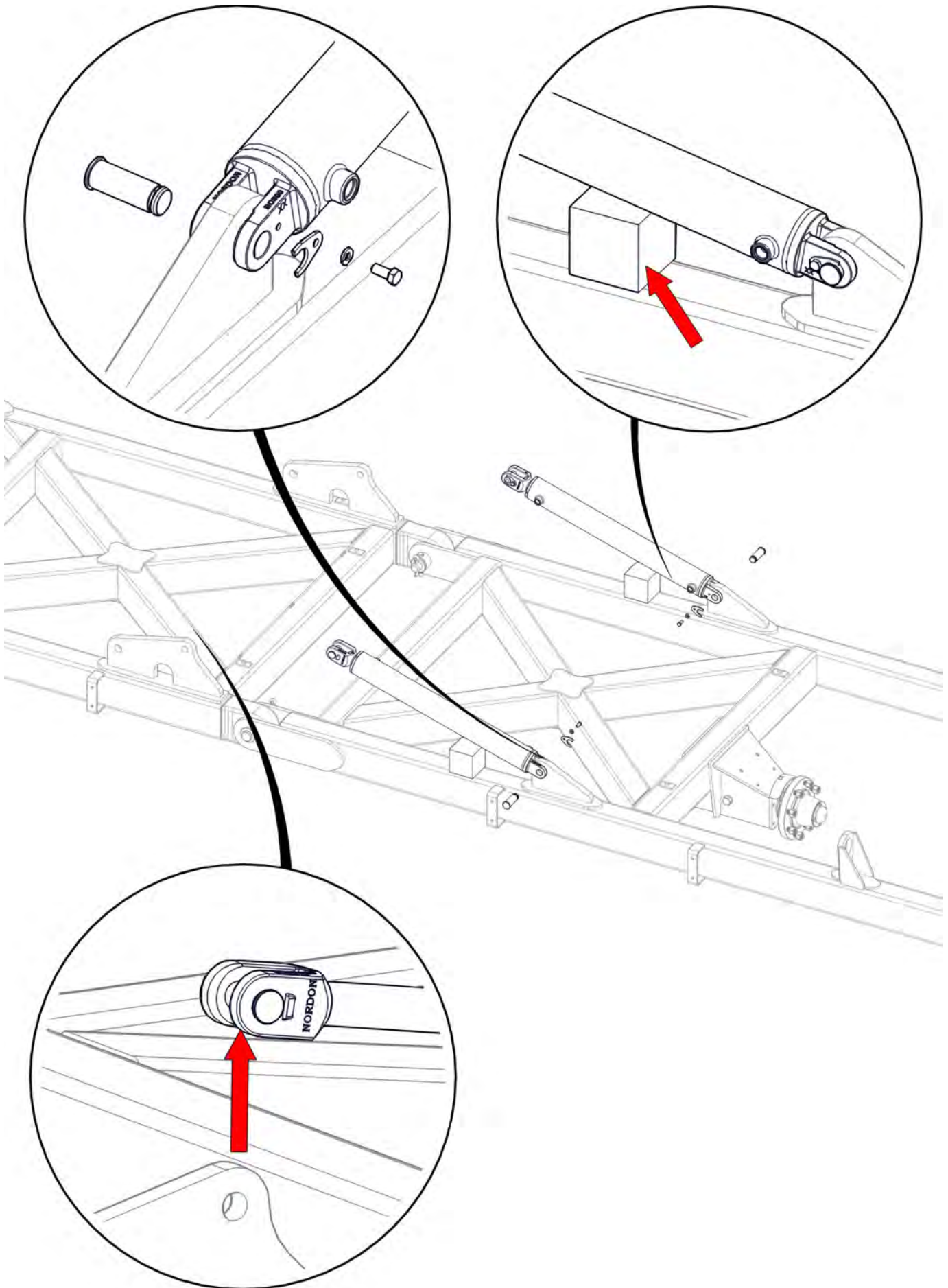

Item No.	Description	Number	Qty
1	3/4" JIC Male 3/4" UN O Ring Male 90° Elbow	0323-S91-1212	4

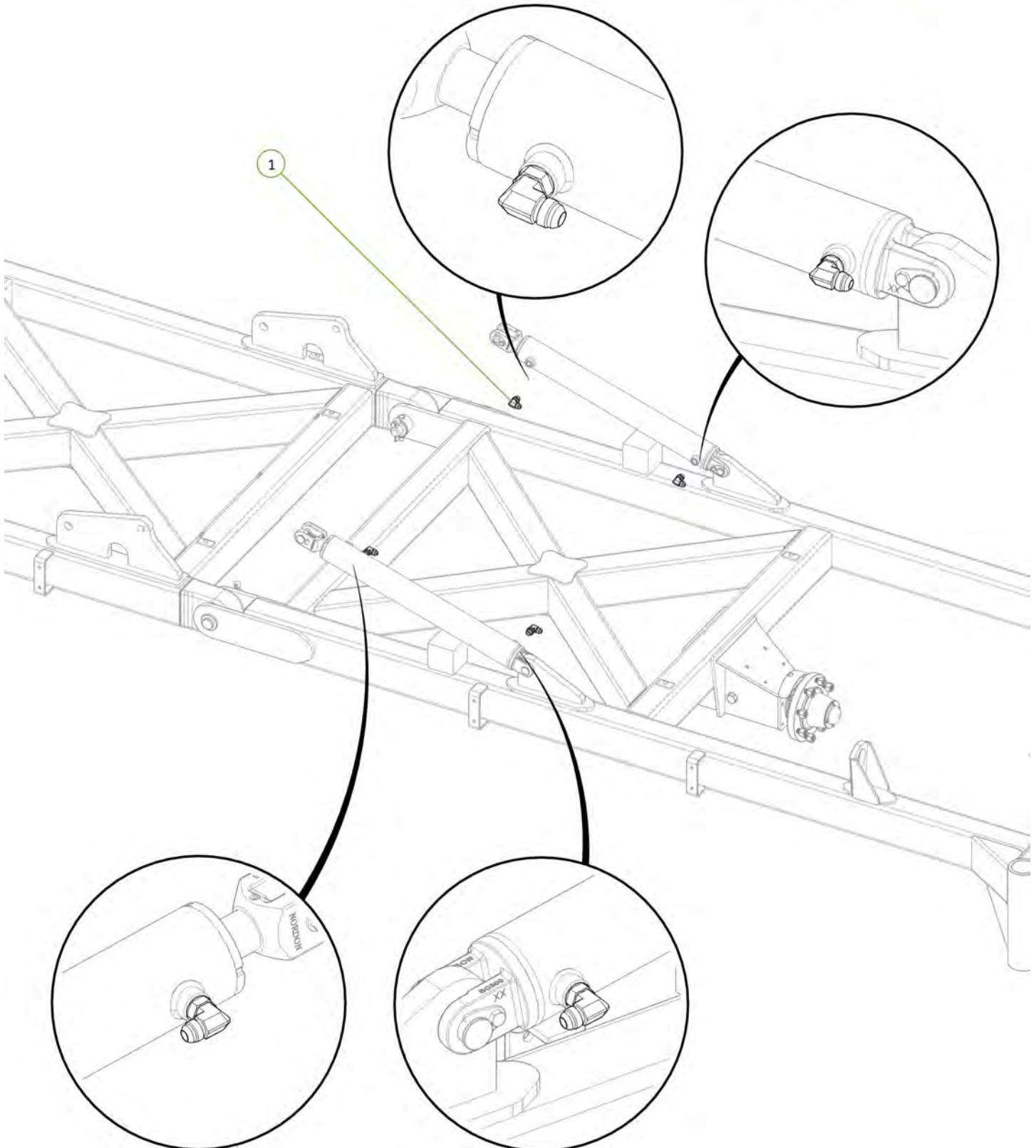

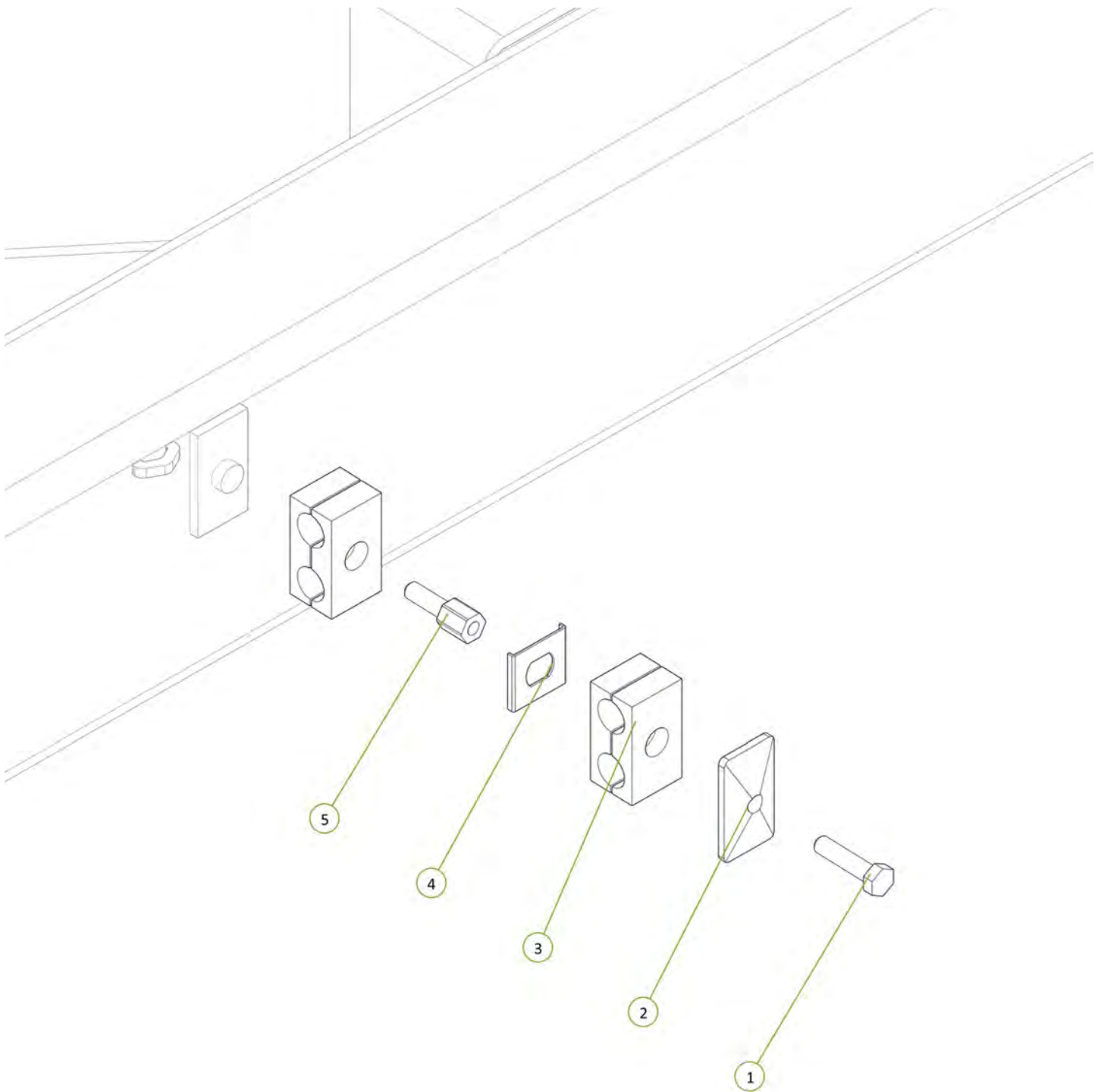

Item No.	Description	Number	Qty
1	Double Clamp Bolt Group 2	0325-RCD-2BH	1
2	Clamp top plate group 2	0325-RCD-2PT	1
3	17mm Clamp Jaws (Pair)	0325-RCD-17J	2
4	Double Clamp Stacking Plate (Non Ryco)	0325-SI-2-5D-W3	1
5	Double Clamp Stacking Bolt Group 2	0325-RCD-2BS	1



Item No.	Description	Number	Qty
1	LH Sequence Valve LE Port to LH Outer Wing Extend Tee	H46-2-21	1
2	LH Sequence Valve LR Port to LH Outer Wing Cylinder Retract Port	H46-2-24	1
3	3/4" JIC Male Tee 3/4" JIC Male Tee 3/4" JIC Male Tee	0324-S19-121212	2

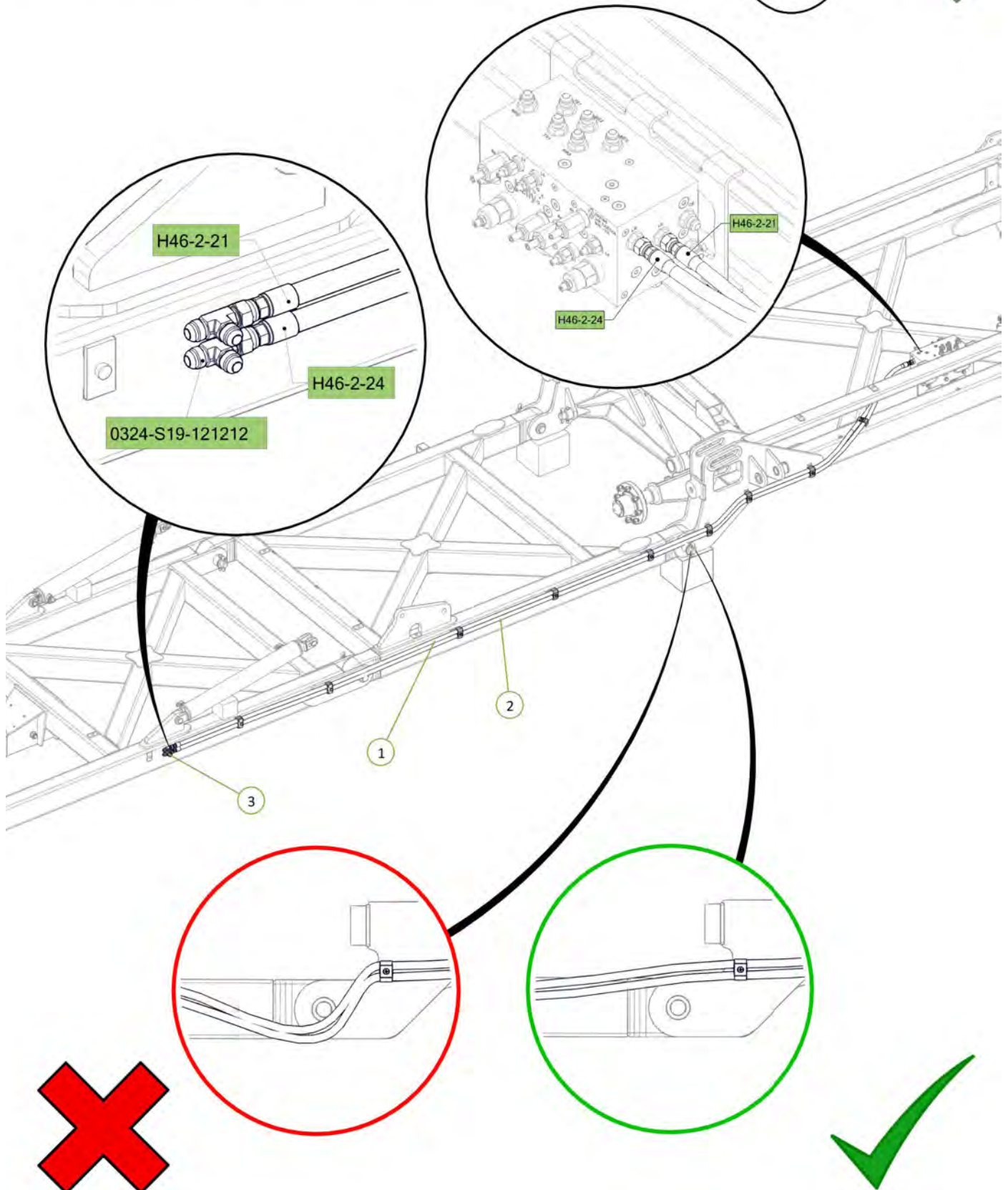

Item No.	Description	Number	Qty
1	LH Outer Wing Extend Tee to LH Inner Wing Front Cylinder Extend Port	H46-2-23	1
2	LH Outer Wing Retract Tee to LH Inner Wing Front Cylinder Retract Port	H46-2-26	1

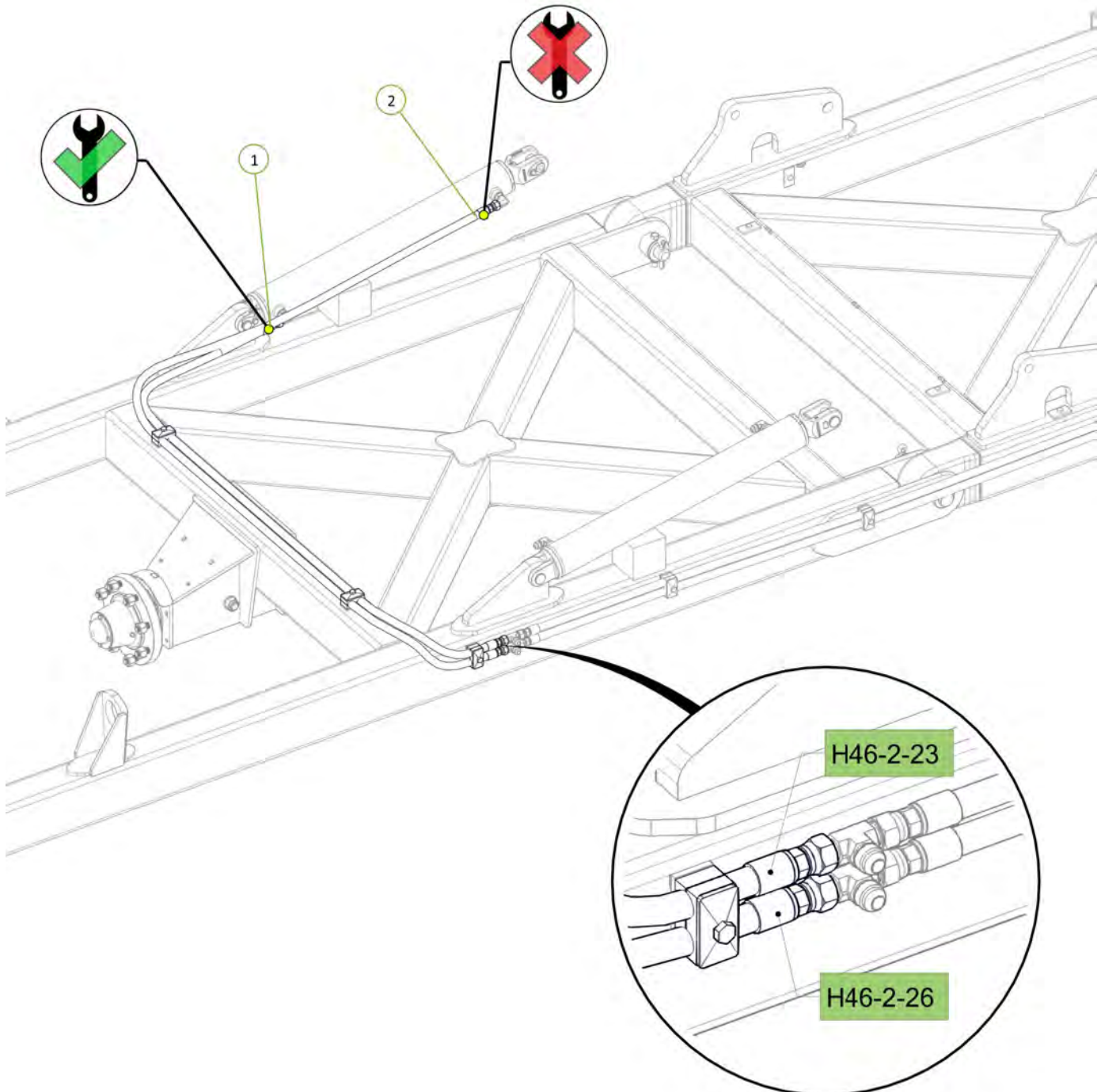

Item No.	Description	Number	Qty
1	LH Outer Wing Extend Tee to LH Inner Wing Rear Cylinder Extend Port	H46-2-22	1
2	LH Outer Wing Retract Tee to LH Inner Wing Rear Cylinder Retract Port	H46-2-25	1

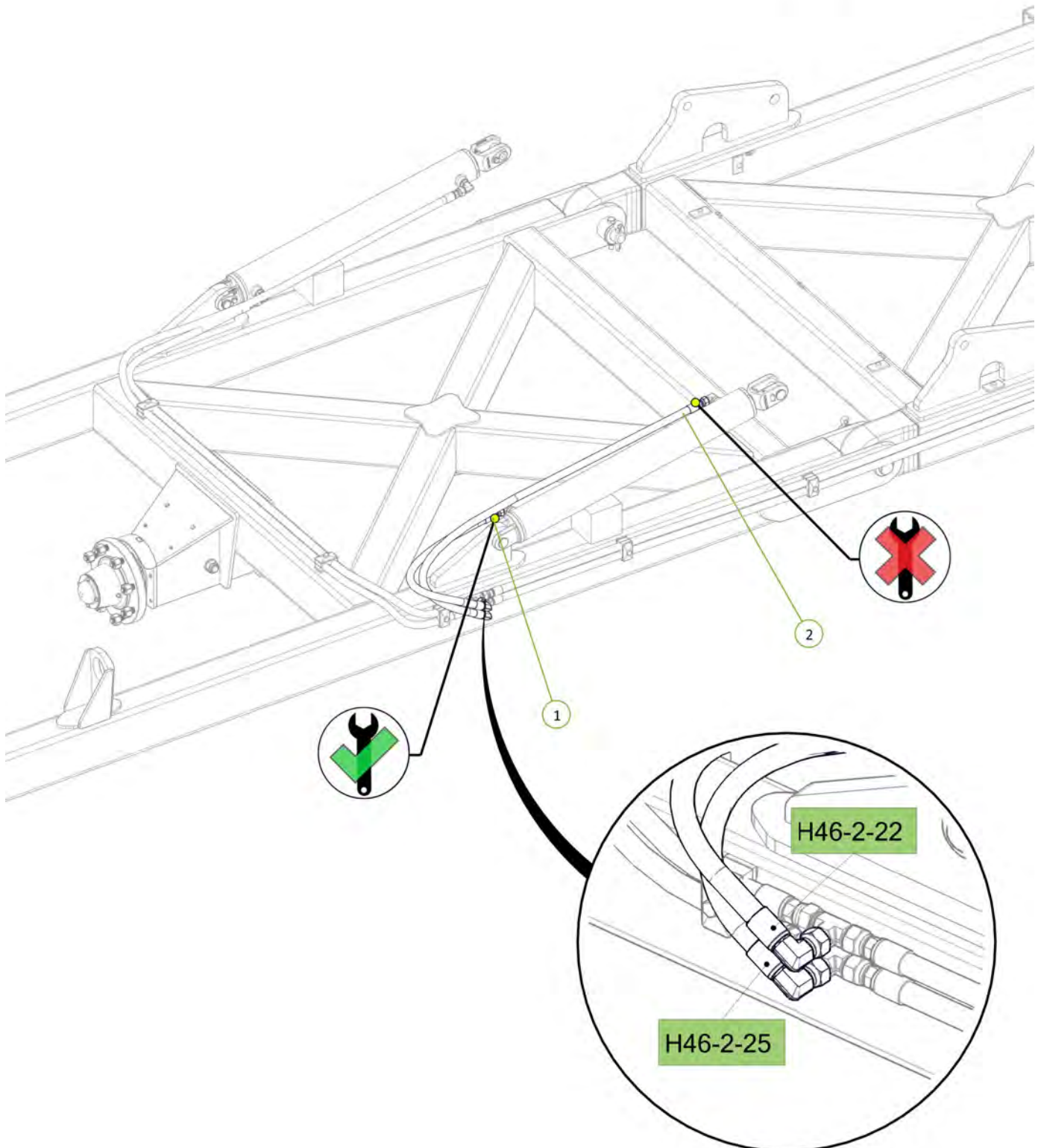

Item No.	Description	Number	Qty
1	5" Bore 30" Stroke 3 1/8" S/Tube 2" Rod Hydraulic Cylinder	0311-530STSP	2

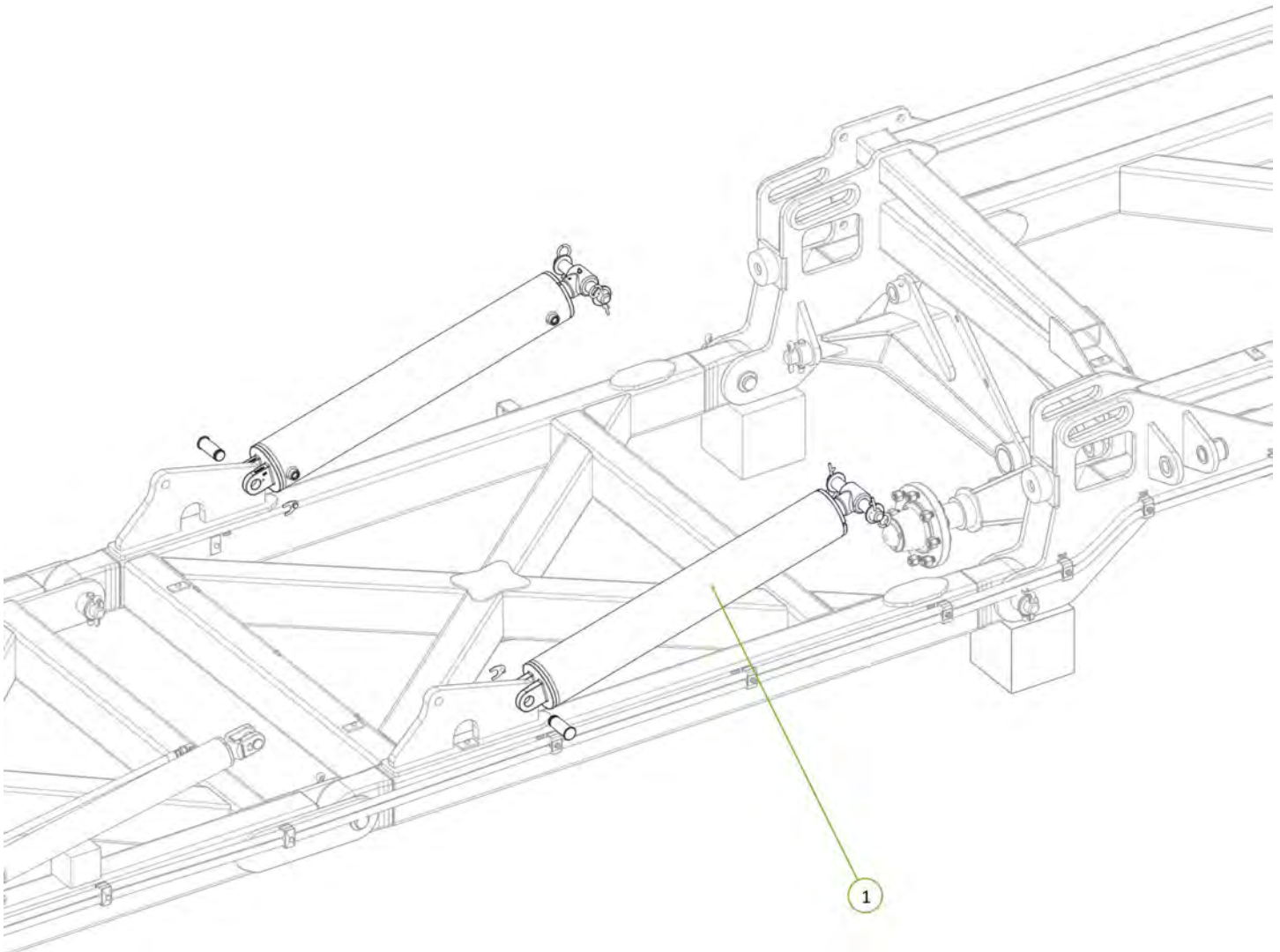

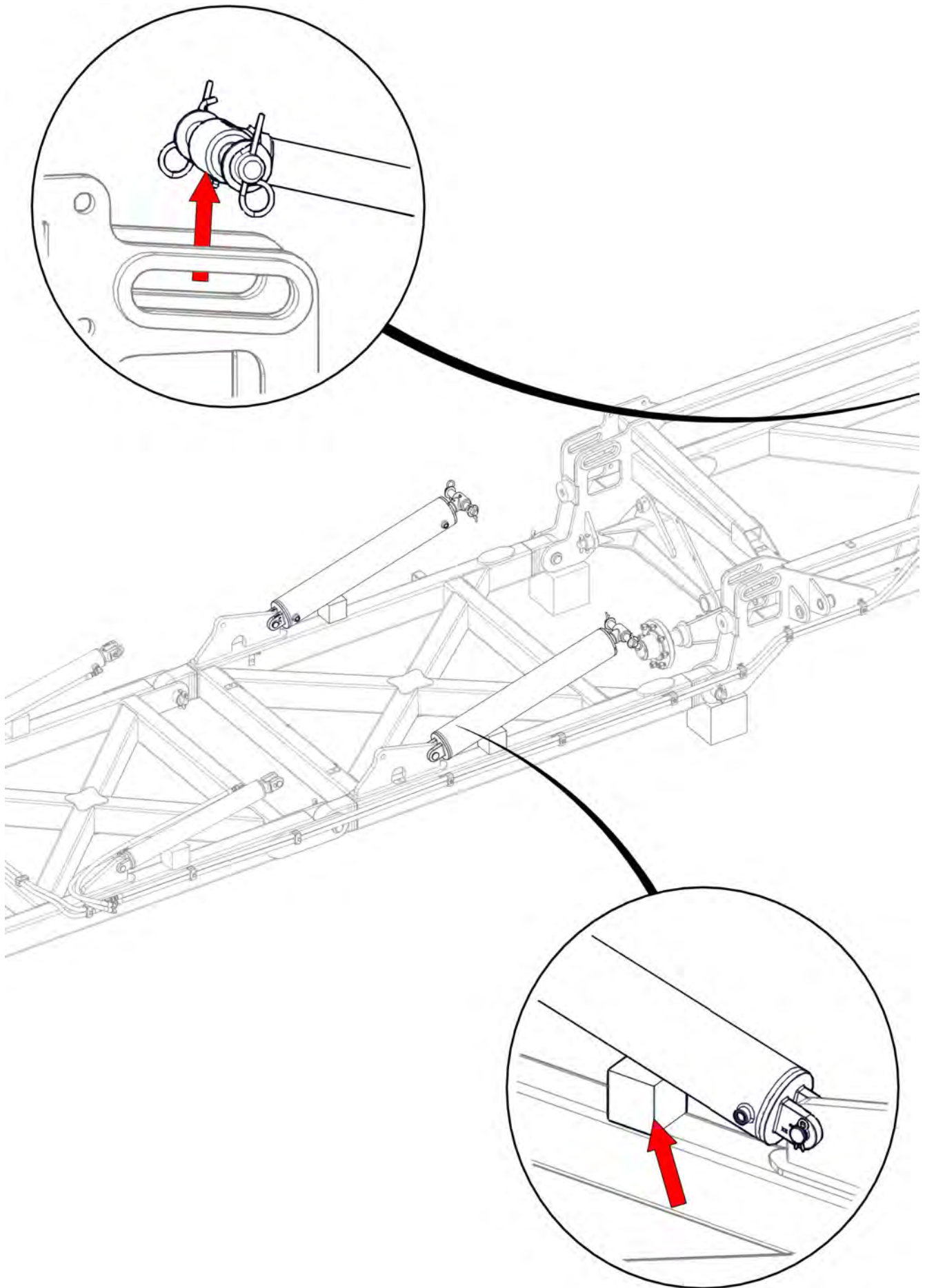

Item No.	Description	Number	Qty
1	3/4" JIC Male 3/4" UN O Ring Male 90° Elbow	0323-S91-1212	4

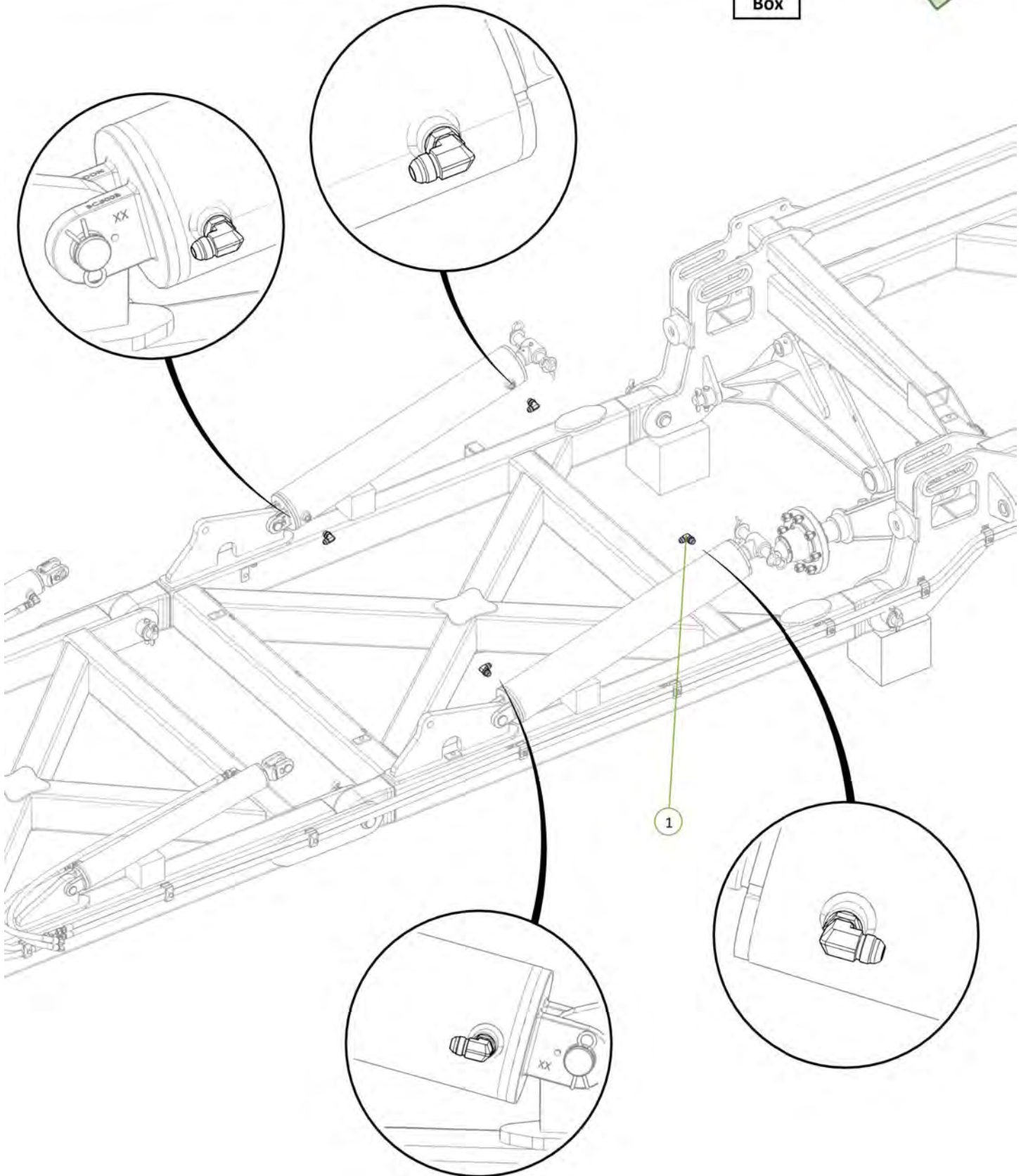

Item No.	Description	Number	Qty
1	LH Sequence Valve CE Port to LH Inner Wing Extend Tee	H46-2-15	1
2	LH Sequence Valve CR Port to LH Inner Wing Retract Tee	H46-2-18	1
3	3/4" JIC Male Tee 3/4" JIC Male Tee 3/4" JIC Male Tee	0324-S19-121212	2

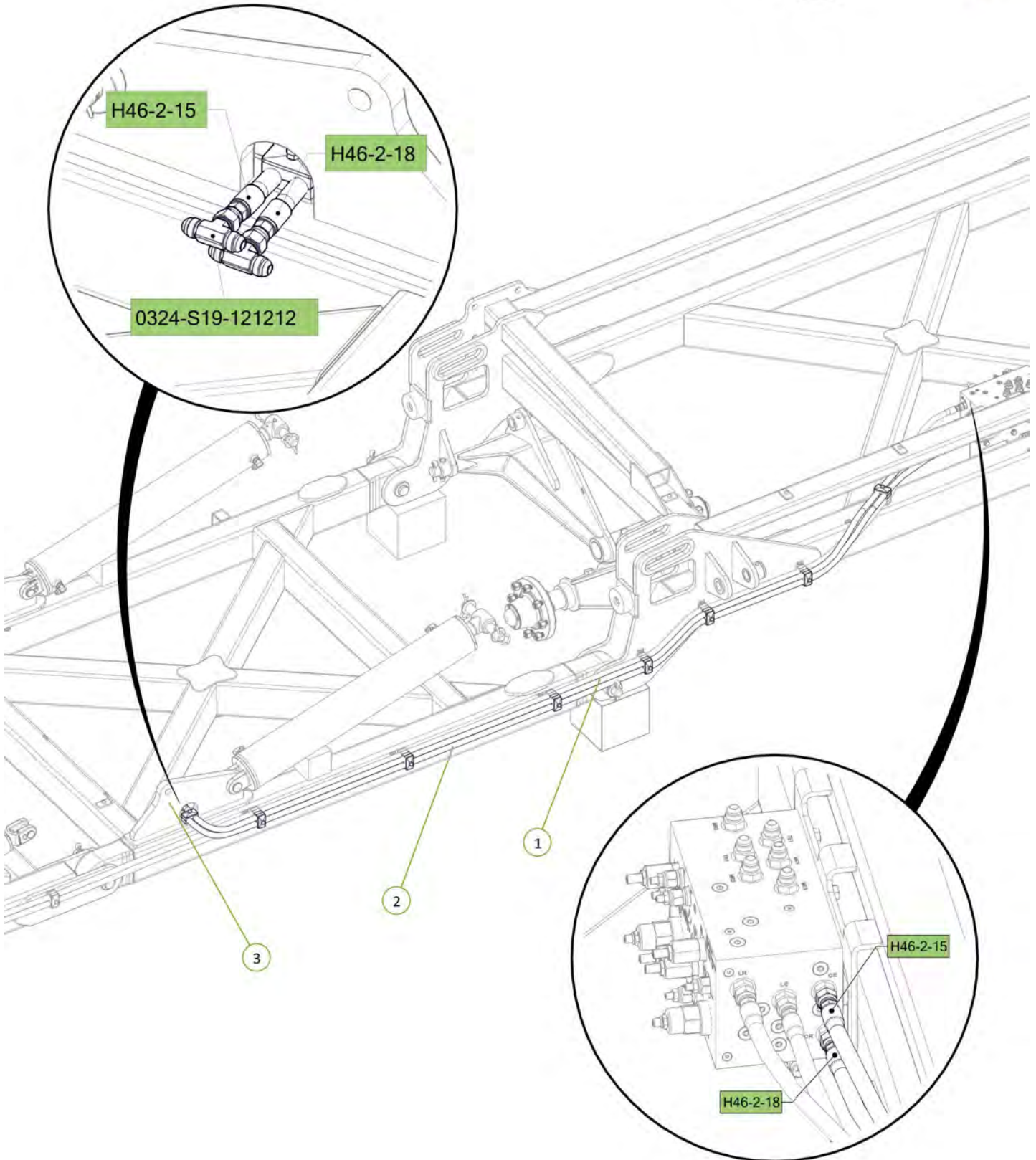

Item No.	Description	Number	Qty
1	LH Inner Wing Extend Tee to LH Inner Wing Rear Cylinder Extend Port	H46-2-16	1
2	LH Inner Wing Retract Tee to LH Inner Wing Rear Cylinder Retract Port	H46-2-19	1

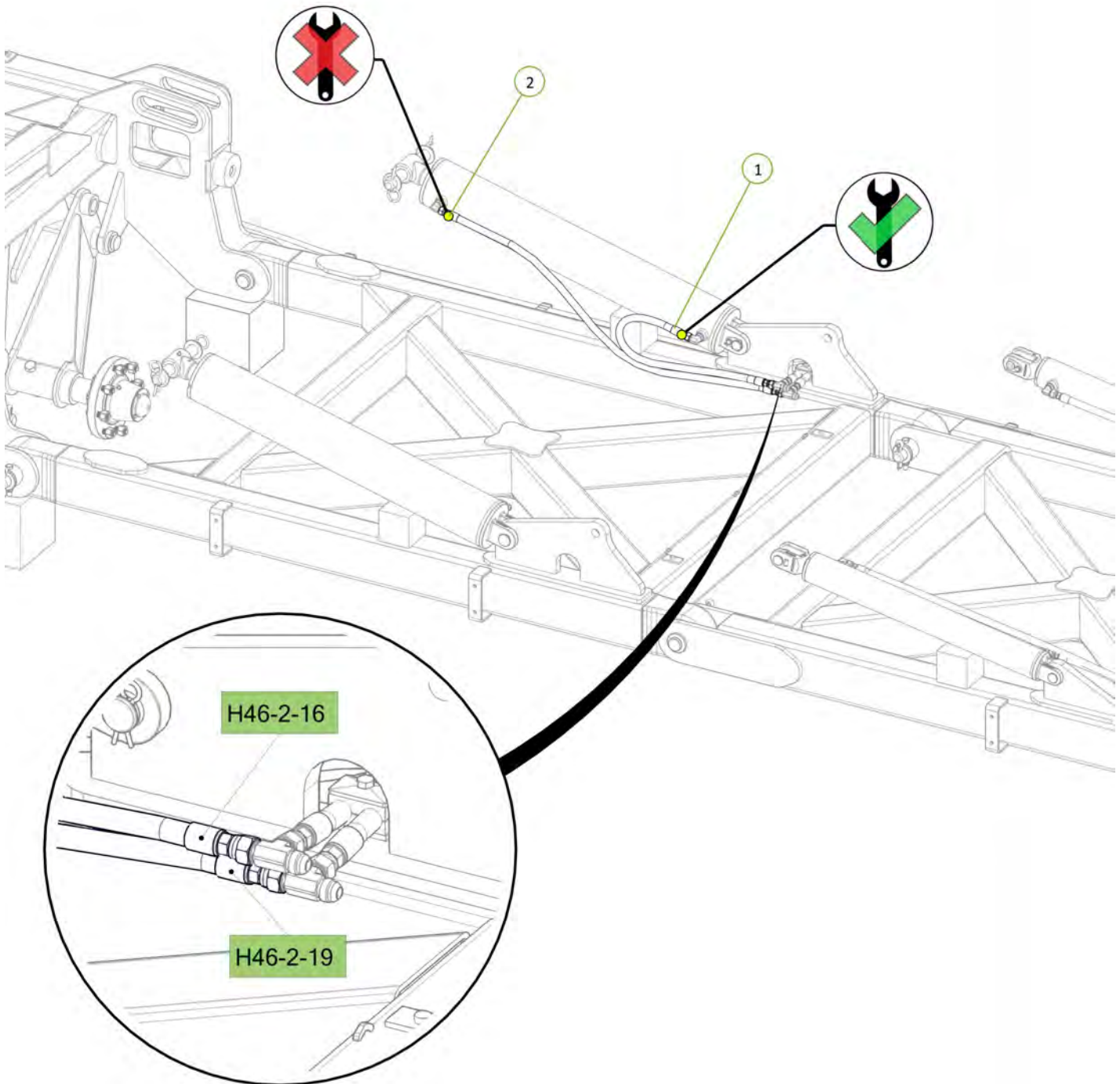

Item No.	Description	Number	Qty
1	LH Inner Wing Extend Tee to LH Inner Wing Front Cylinder Extend Port	H46-2-17	1
2	LH Inner Wing Retract Tee to LH Inner Wing Front Cylinder Retract Port	H46-2-20	1

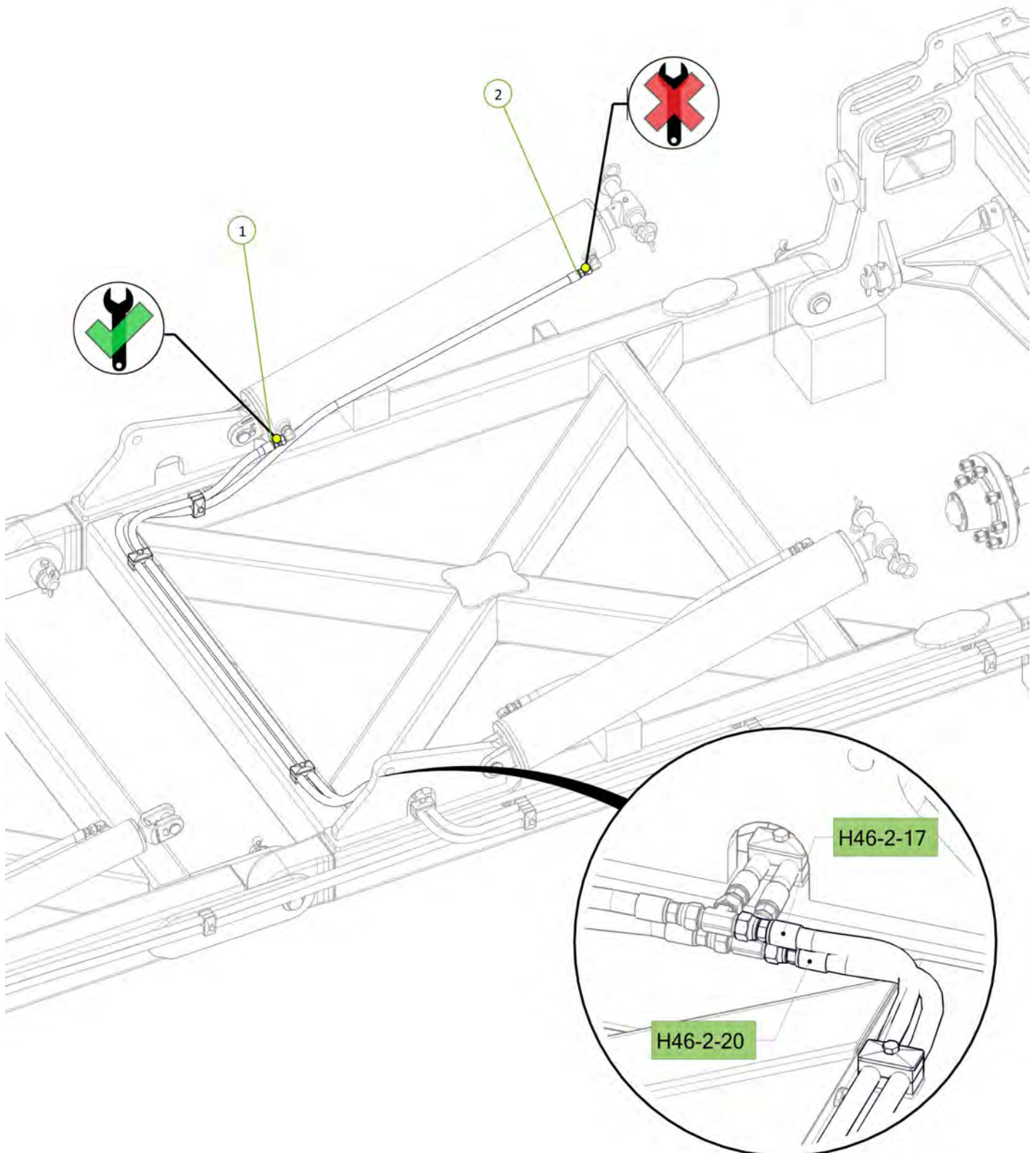

Item No.	Description	Number	Qty
1	3" Bore x 24" Stroke 1.5" Rod Hydraulic Cylinder Side Port	0311-324STSP	2

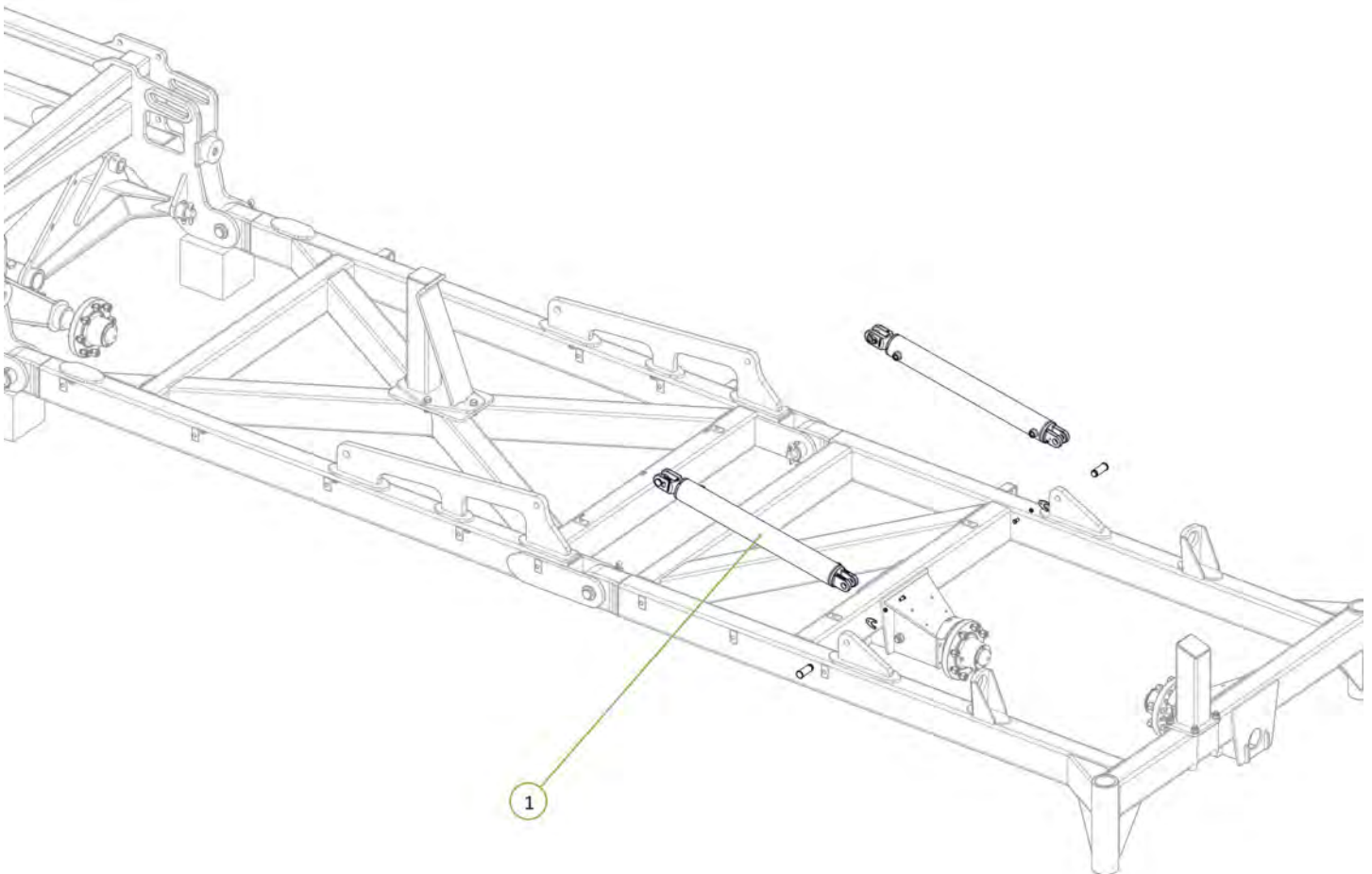

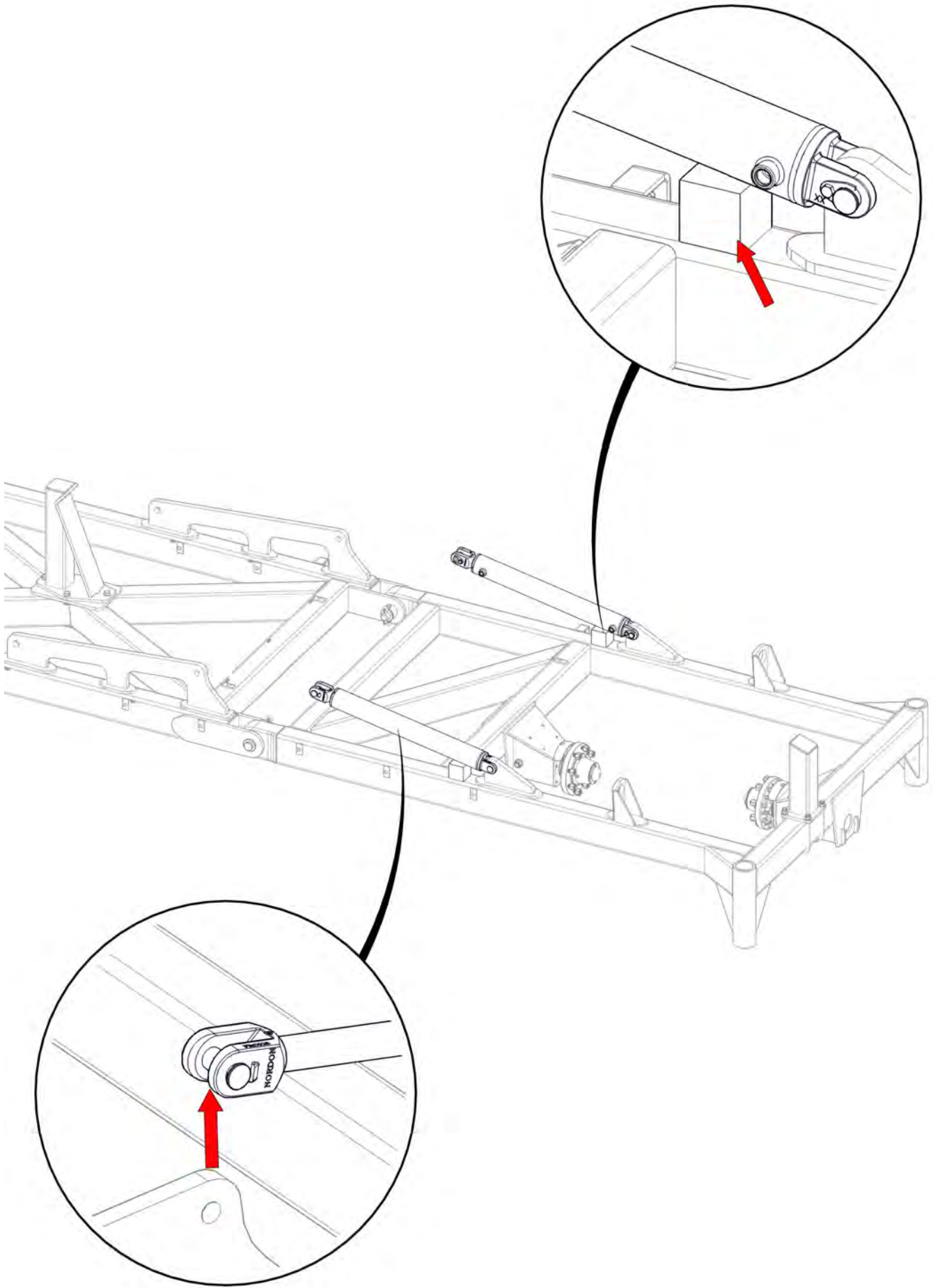

Item No.	Description	Number	Qty
1	3/4" JIC Male 3/4" UN O Ring Male 90° Elbow	0323-S91-1212	4

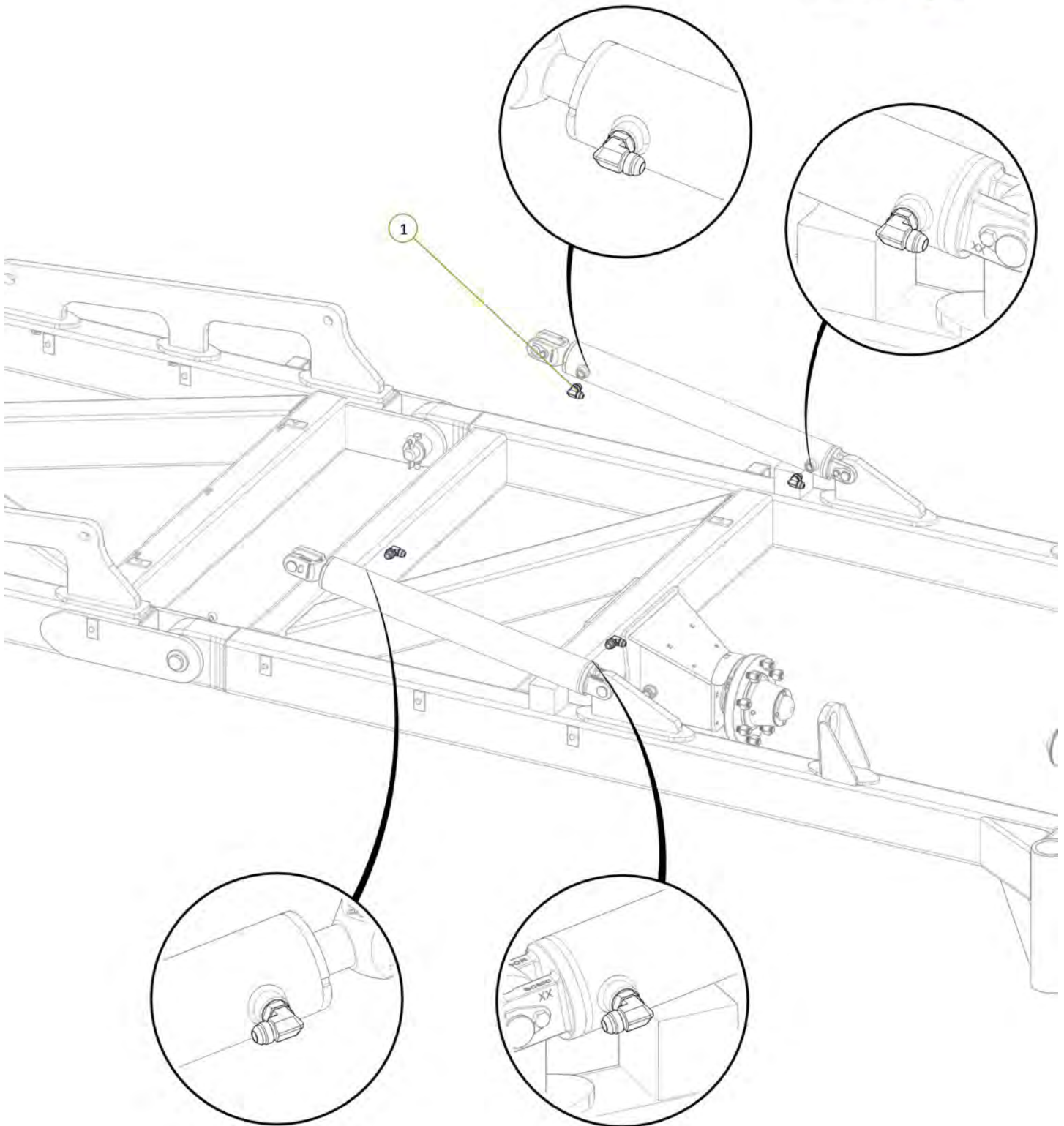

Item No.	Description	Number	Qty
1	RH Sequence Valve RE Port to RH Outer Wing Extend Tee	H46-2-33	1
2	RH Sequence Valve RR Port to RH Outer Wing Retract Tee	H46-2-36	1
3	3/4" JIC Male Tee 3/4" JIC Male Tee 3/4" JIC Male Tee	0324-S19-121212	2

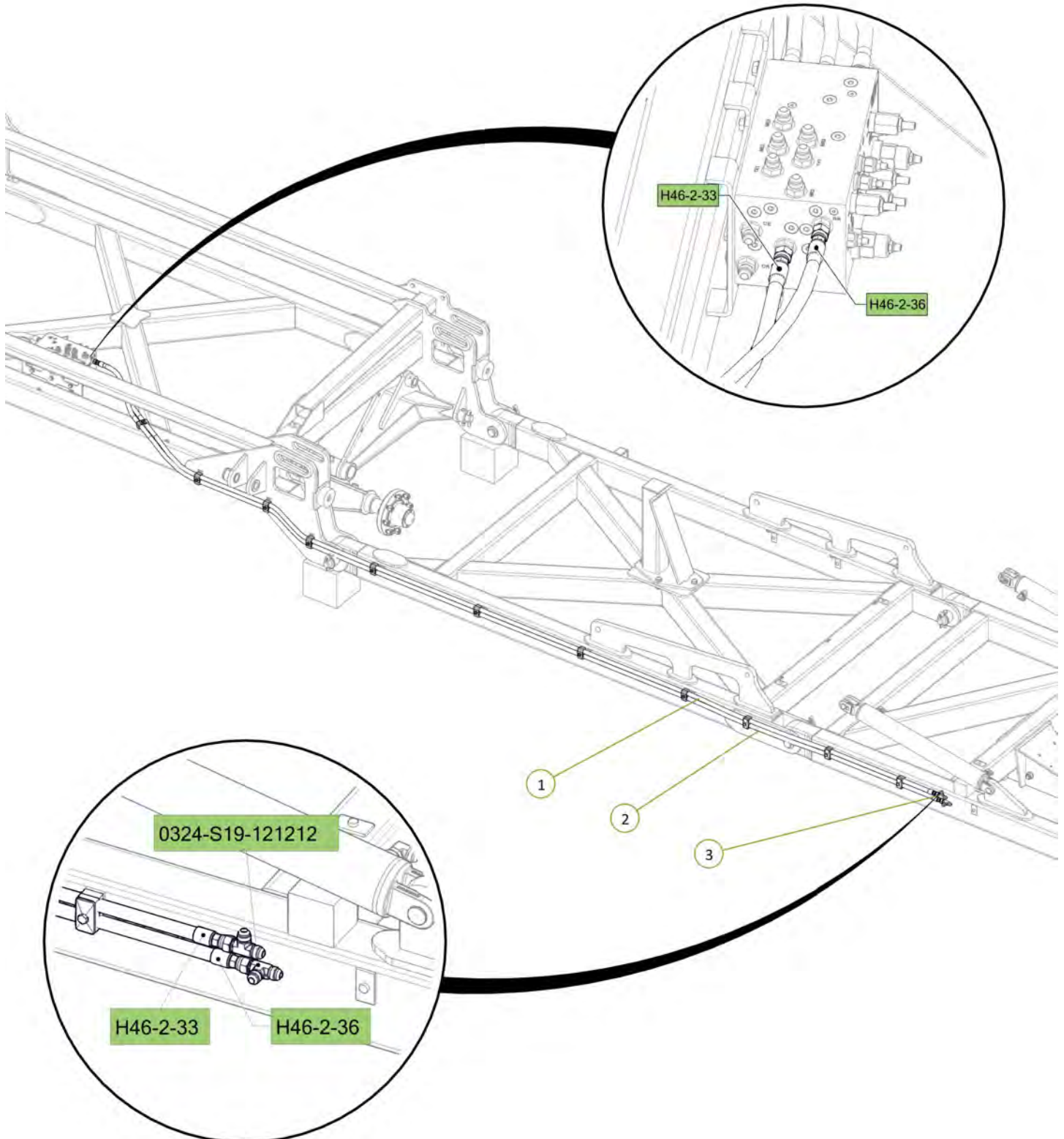
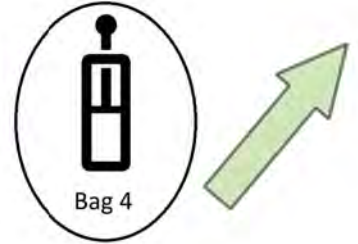

Item No.	Description	Number	Qty
1	RH Outer Wing Extend Tee to RH Inner Wing Rear Cylinder Extend Port	H46-2-34	1
2	RH Outer Wing Retract Tee to RH Inner Wing Rear Cylinder Retract Port	H46-2-37	1

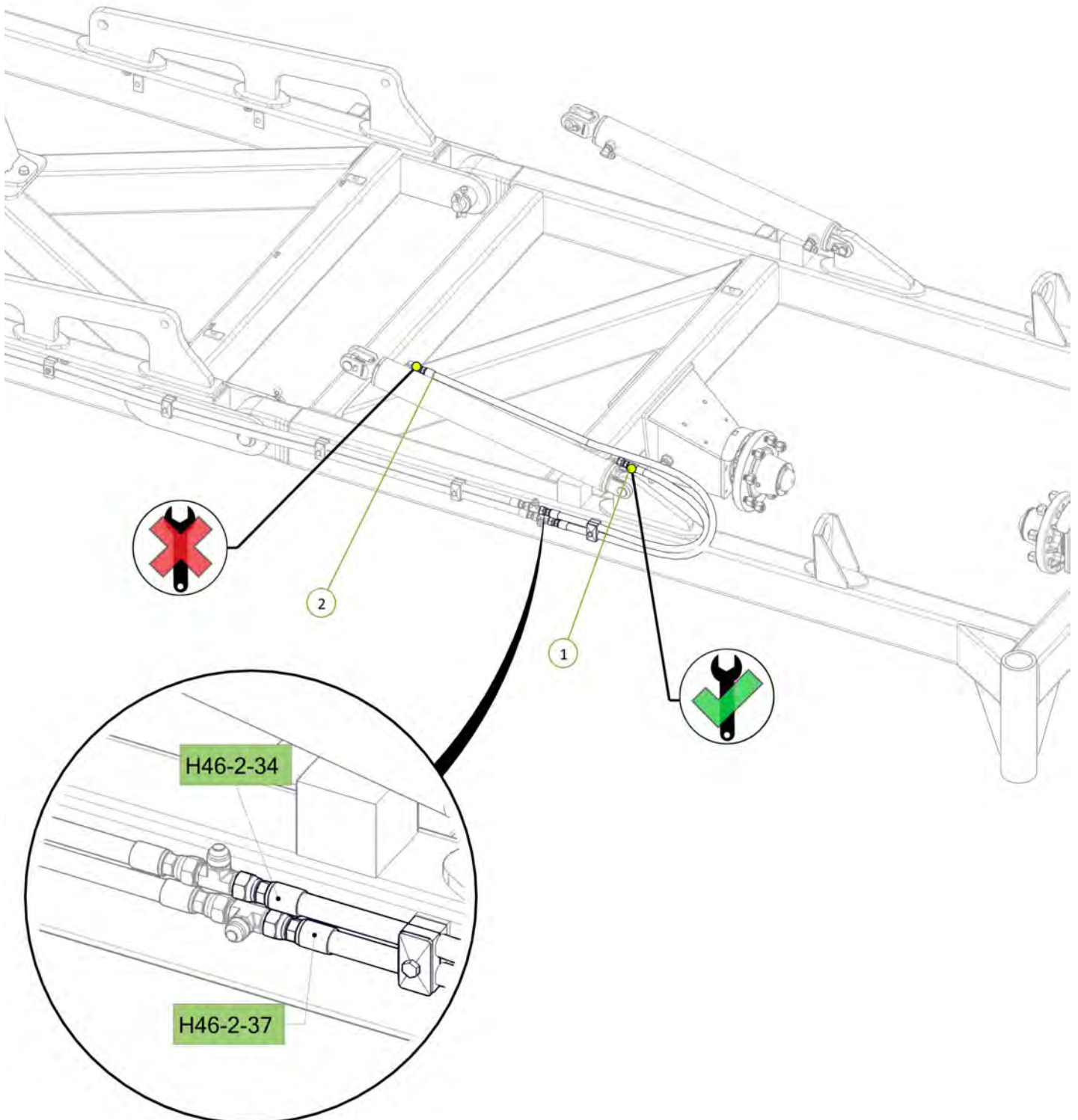
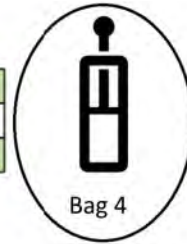

Item No.	Description	Number	Qty
1	RH Outer Wing Extend Tee to RH Inner Wing Front Cylinder Extend Port	H46-2-35	1
2	RH Outer Wing Retract Tee to RH Inner Wing Front Cylinder Retract Port	H46-2-38	1
3	3/4" JIC Male 3/4" JIC Female Swivel 90° Elbow	0323-S15-1212	1

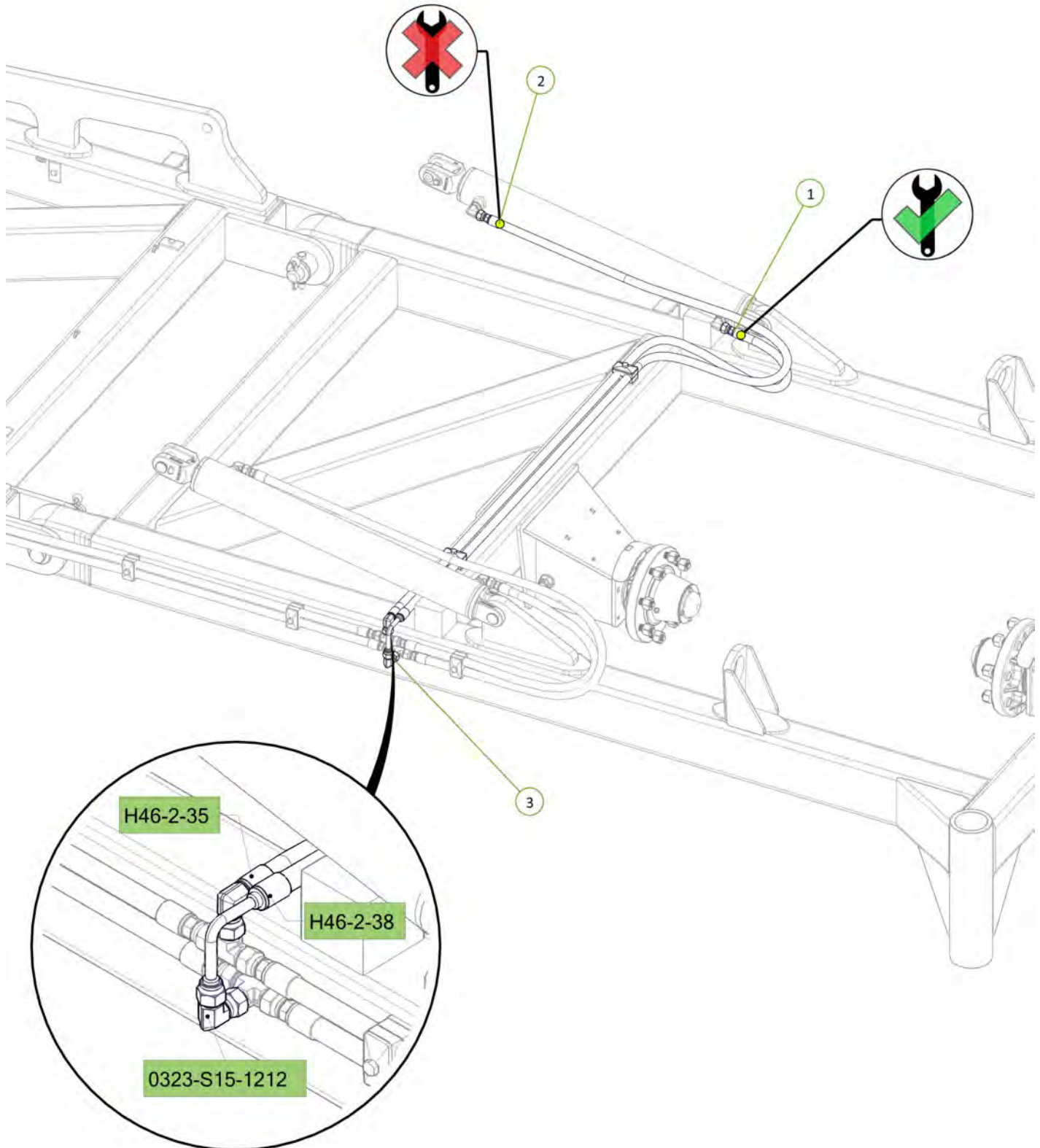

Item No.	Description	Number	Qty
1	5" Bore 30" Stroke 3 1/8" S/Tube 2" Rod Hydraulic Cylinder	0311-530TSP	2

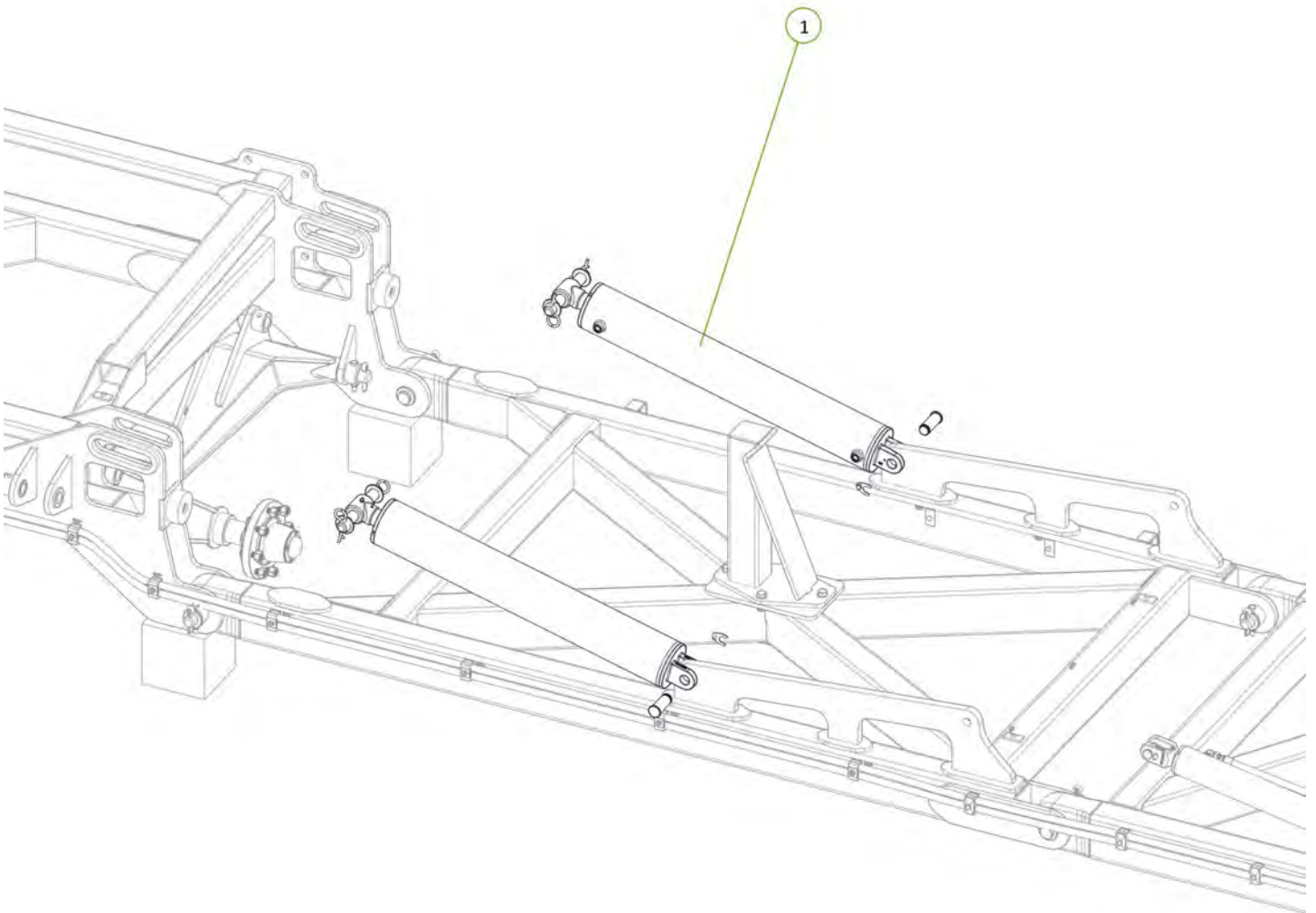

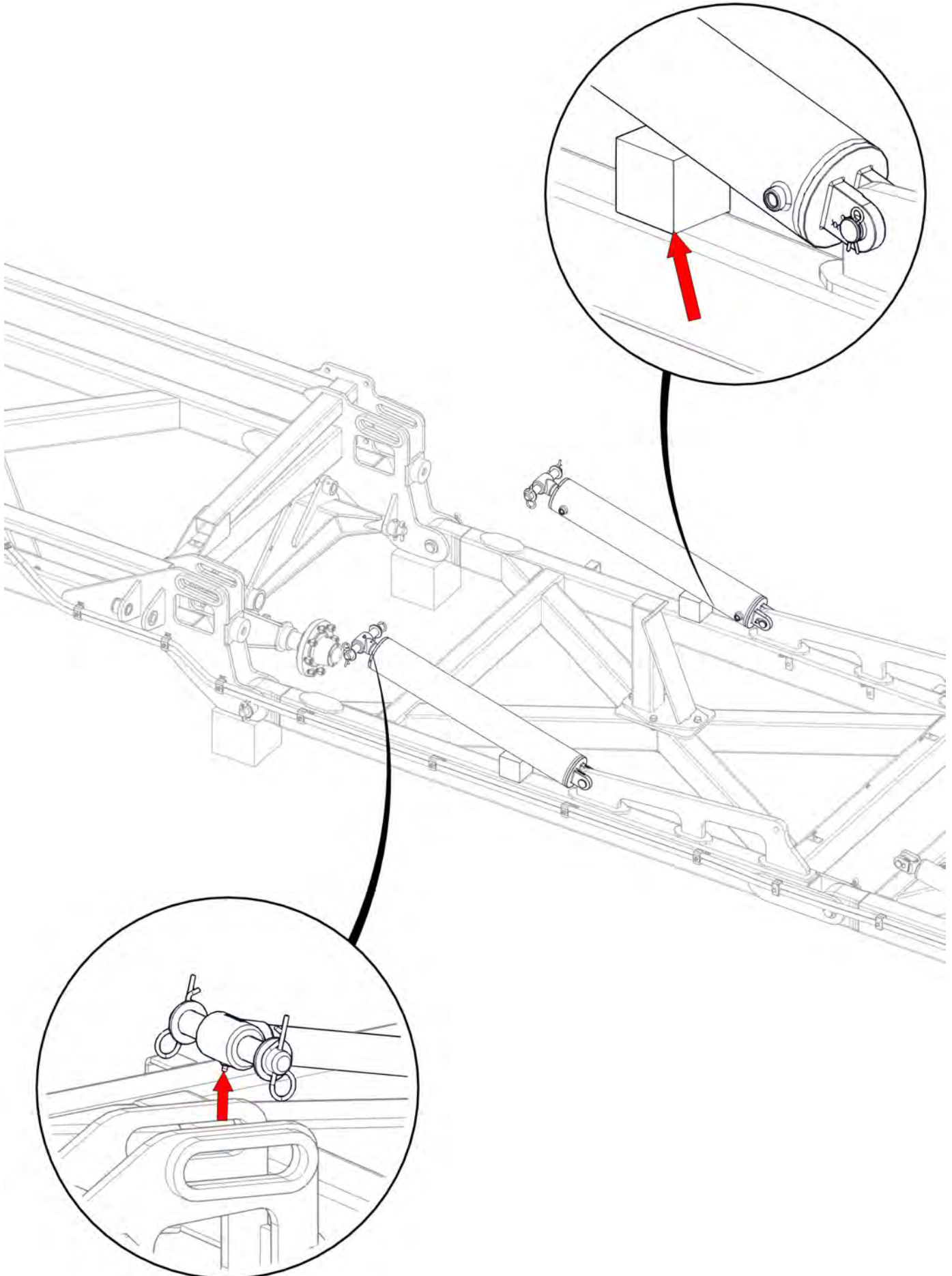

Item No.	Description	Number	Qty
1	3/4" JIC Male 3/4" UN O Ring Male 90° Elbow	0323-591-1212	4

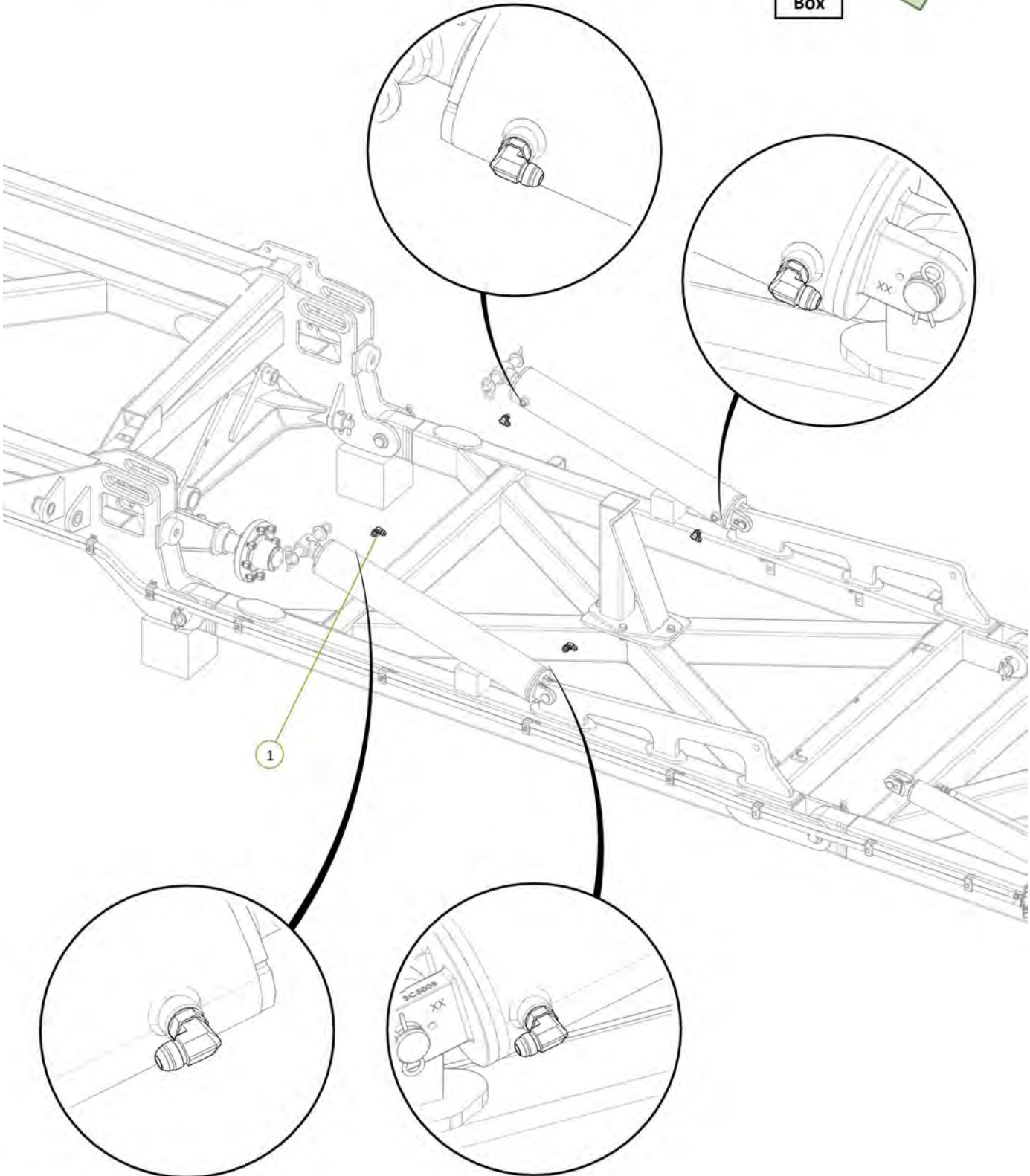

Item No.	Description	Number	Qty
1	RH Sequence Valve CE Port to RH Inner Wing Extend Tee	H46-2-27	1
2	RH Sequence Valve CR Port to RH Inner Wing Retract Tee	H46-2-30	1
3	3/4" JIC Male Tee 3/4" JIC Male Tee 3/4" JIC Male Tee	0324-S19-121212	2

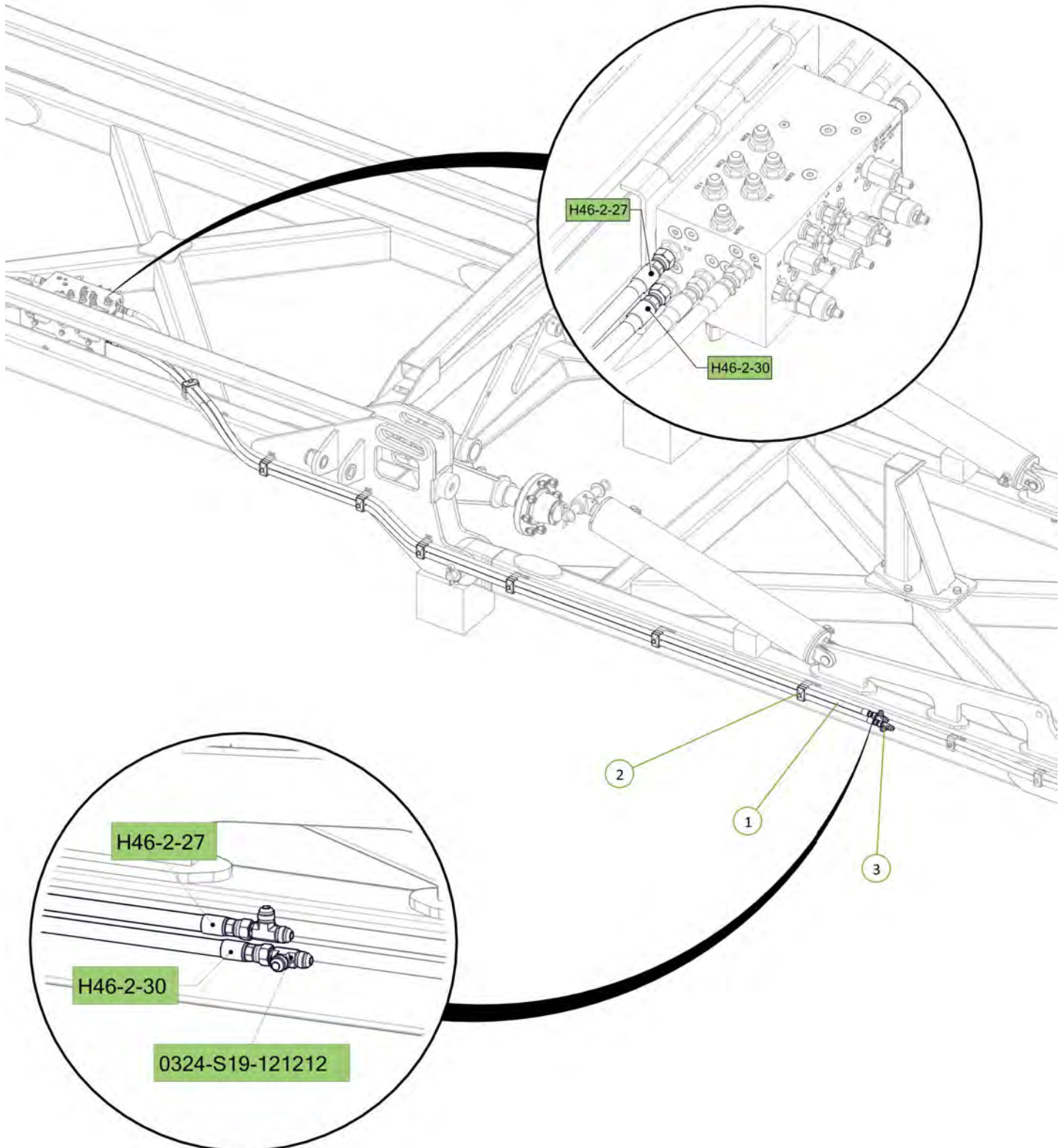

Item No.	Description	Number	Qty
1	RH Inner Wing Extend Tee to RH Inner Wing Front Cylinder Extend Port	H46-2-29	1
2	RH Inner Wing Retract Tee to RH Inner Wing Front Cylinder Retract Port	H46-2-32	1

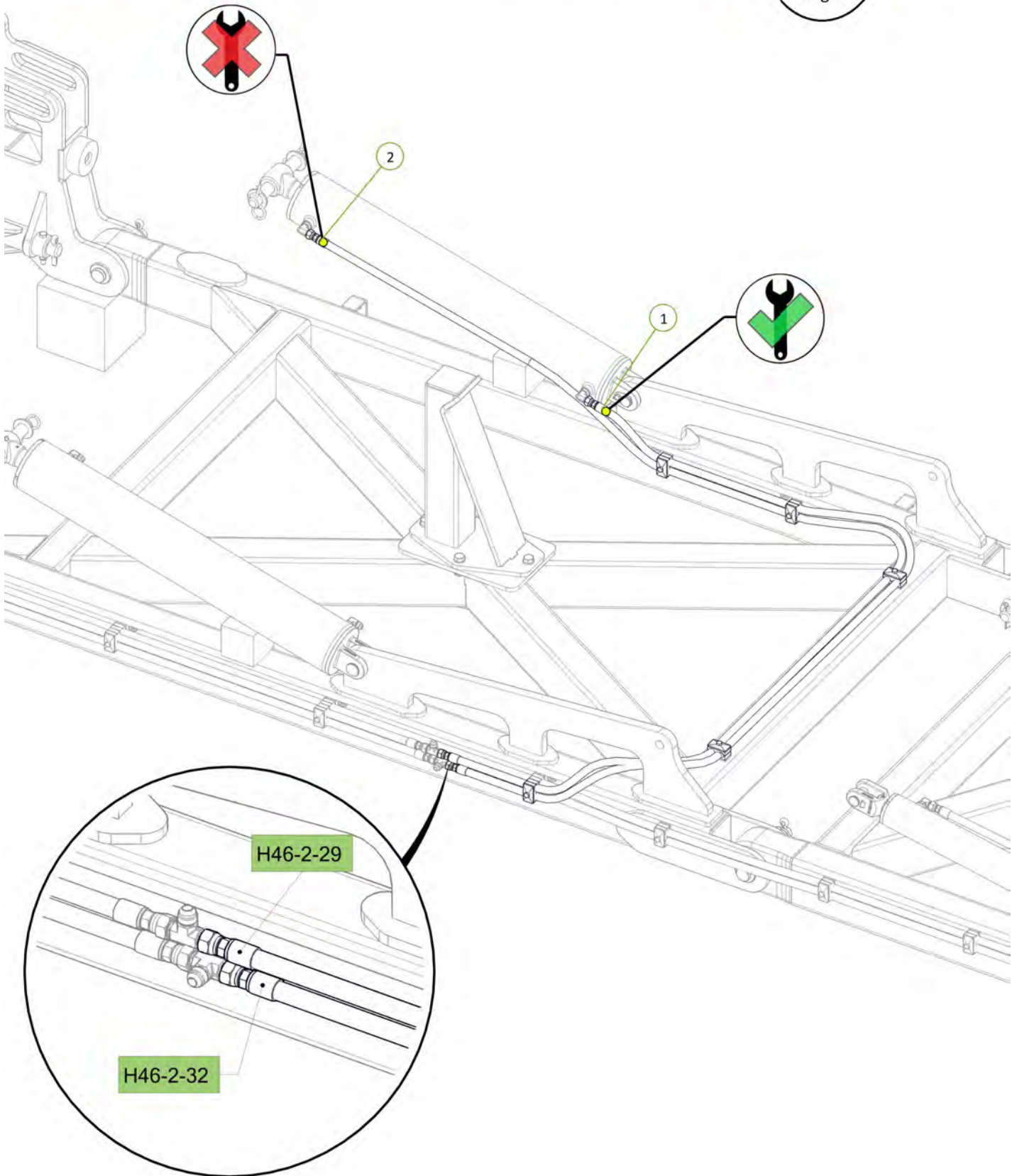
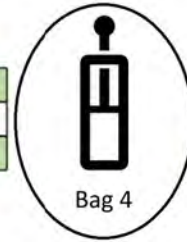

Item No.	Description	Number	Qty
1	RH Inner Wing Extend Tee to RH Inner Wing Rear Cylinder Extend Port	H46-2-28	1
2	RH Inner Wing Retract Tee to RH Inner Wing Rear Cylinder Retract Port	H46-2-31	1
3	3/4" JIC Male 3/4" JIC Female Swivel 90° Elbow	0323-S15-1212	1

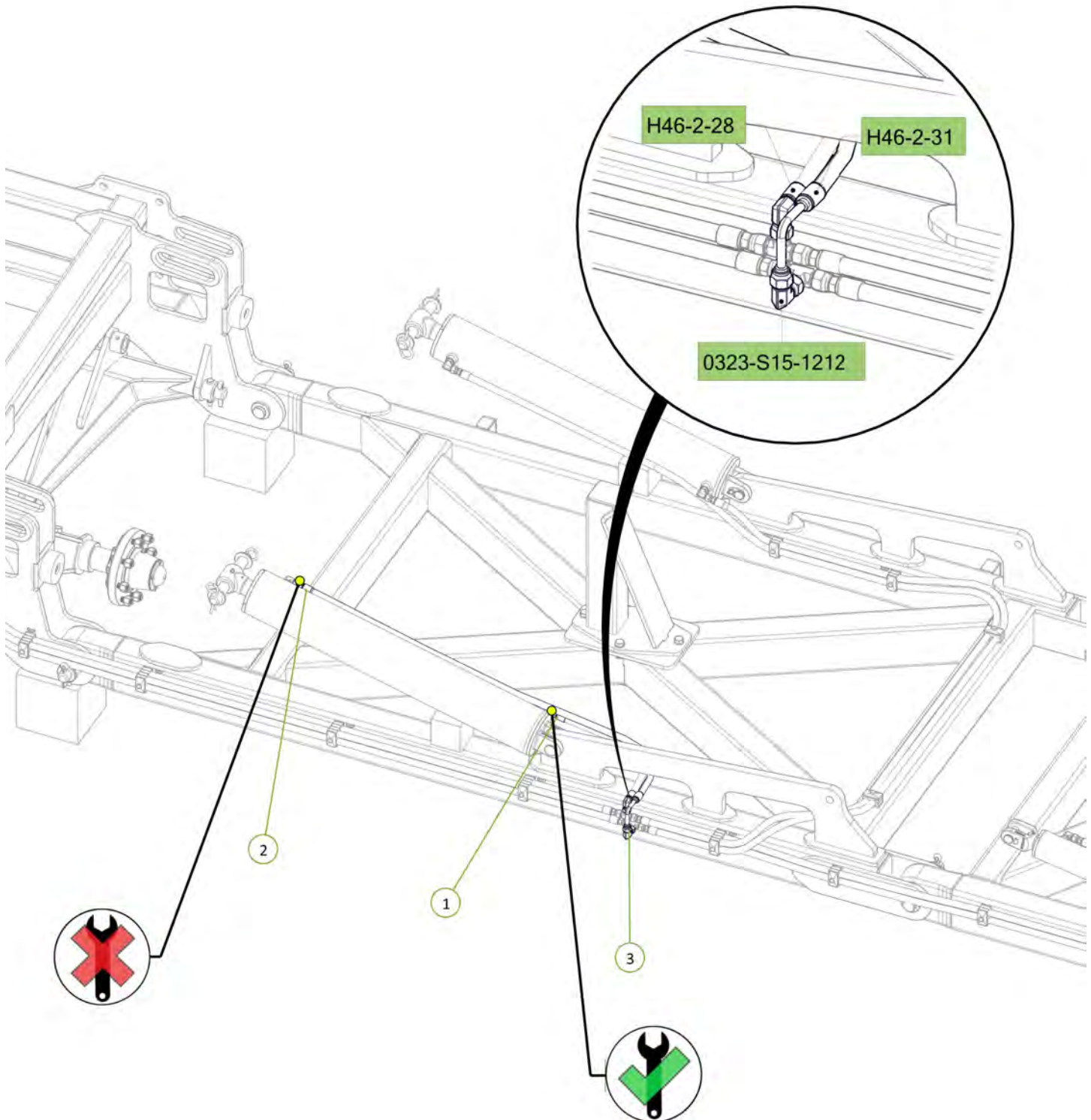

Item No.	Description	Number	Qty
1	Tractor to Sequence Valve EXT1 Port Fitted With Green EXT Decal	H46-2-01-GE-EXT1	1
2	Tractor to Sequence Valve RCT1 Port Fitted With Green RET Decal	H46-2-02-GR-RCT1	1

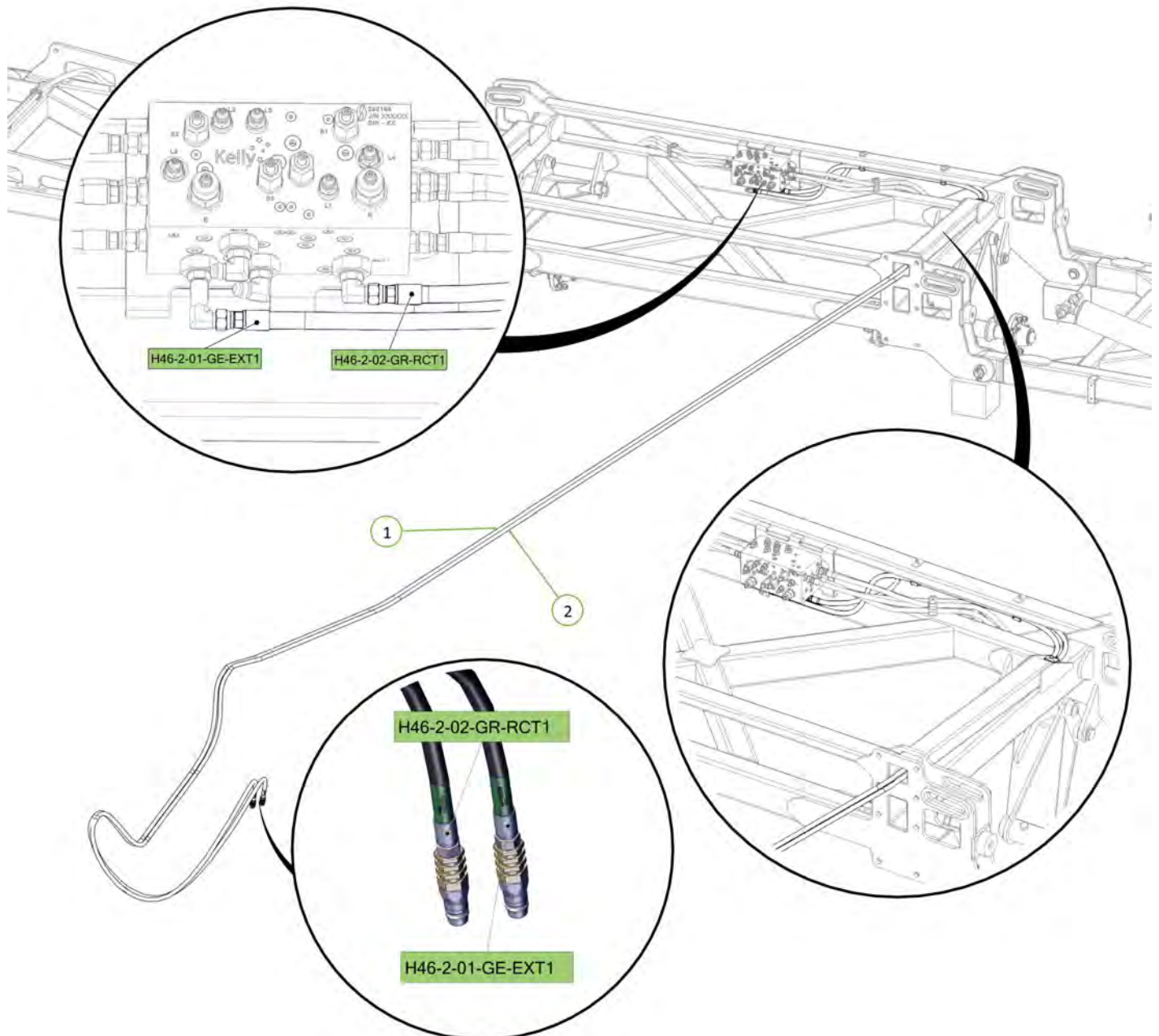

Ensure retract hose fittings are loose to allow air to escape

Check cylinders chocked up to prevent clashing during extension

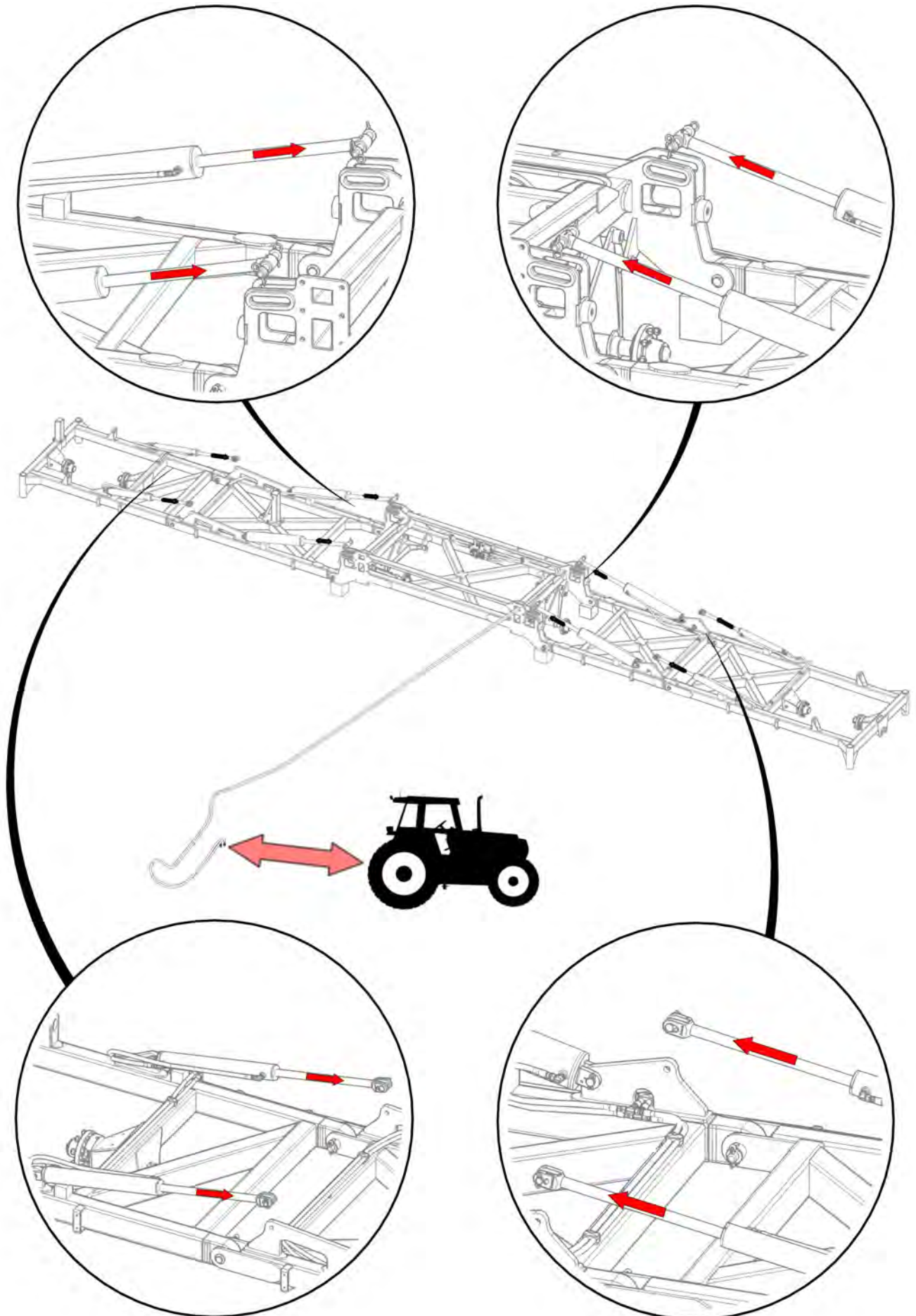

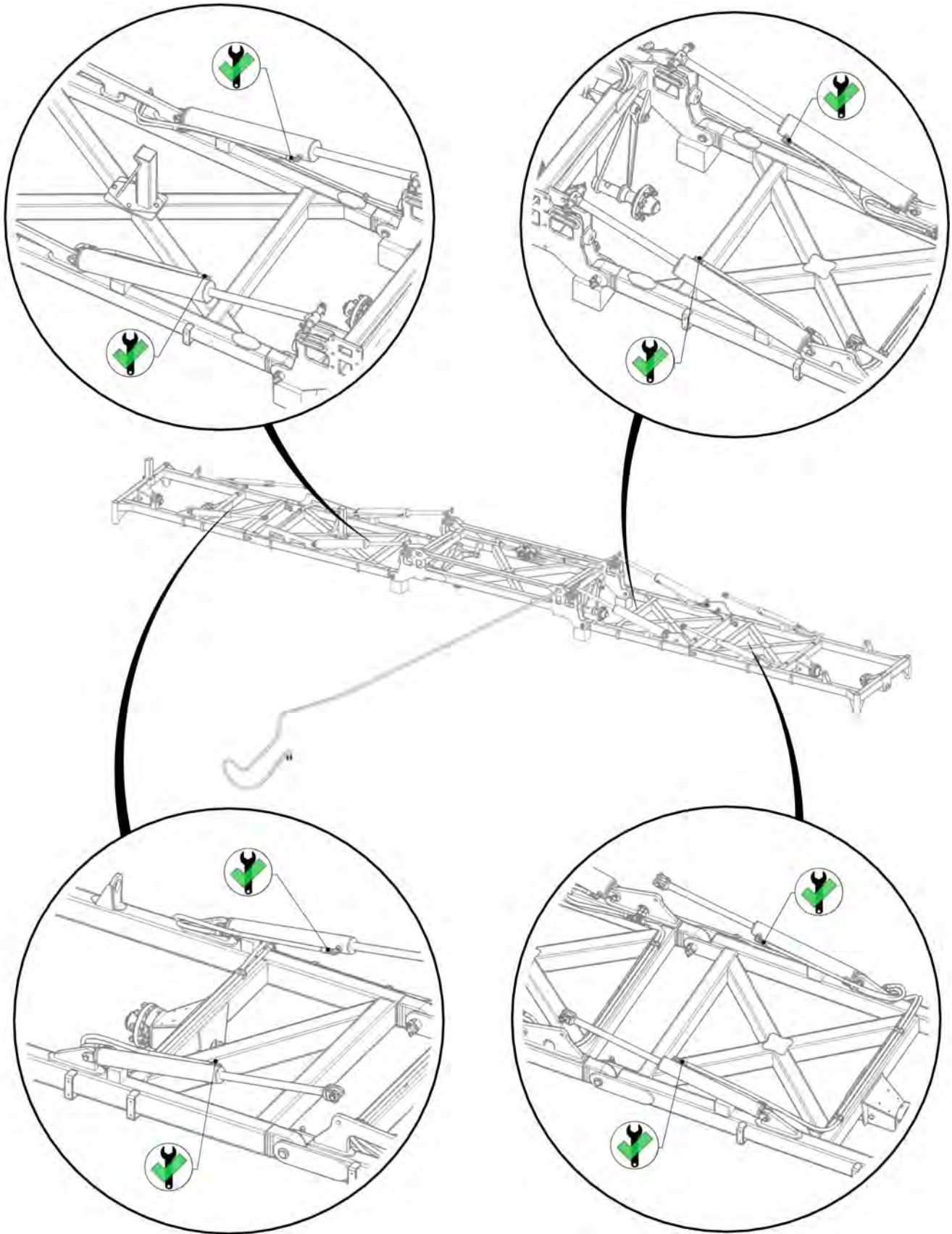

Tighten retract fittings

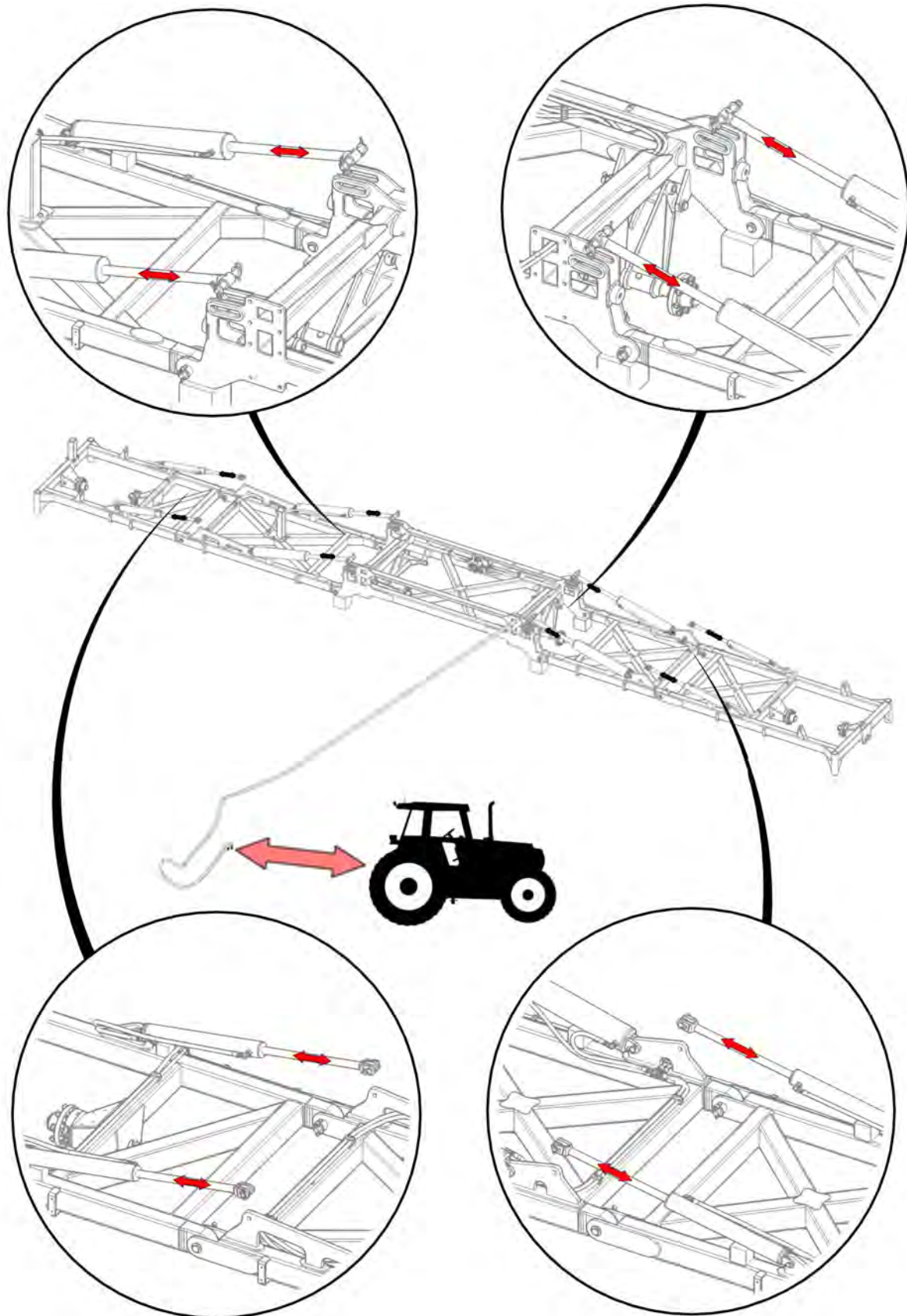

Cycle cylinders to expel air from system

Item No.	Description	Number	Qty
1	Long Cylinder Pin Bearing Bush	1201-19	8

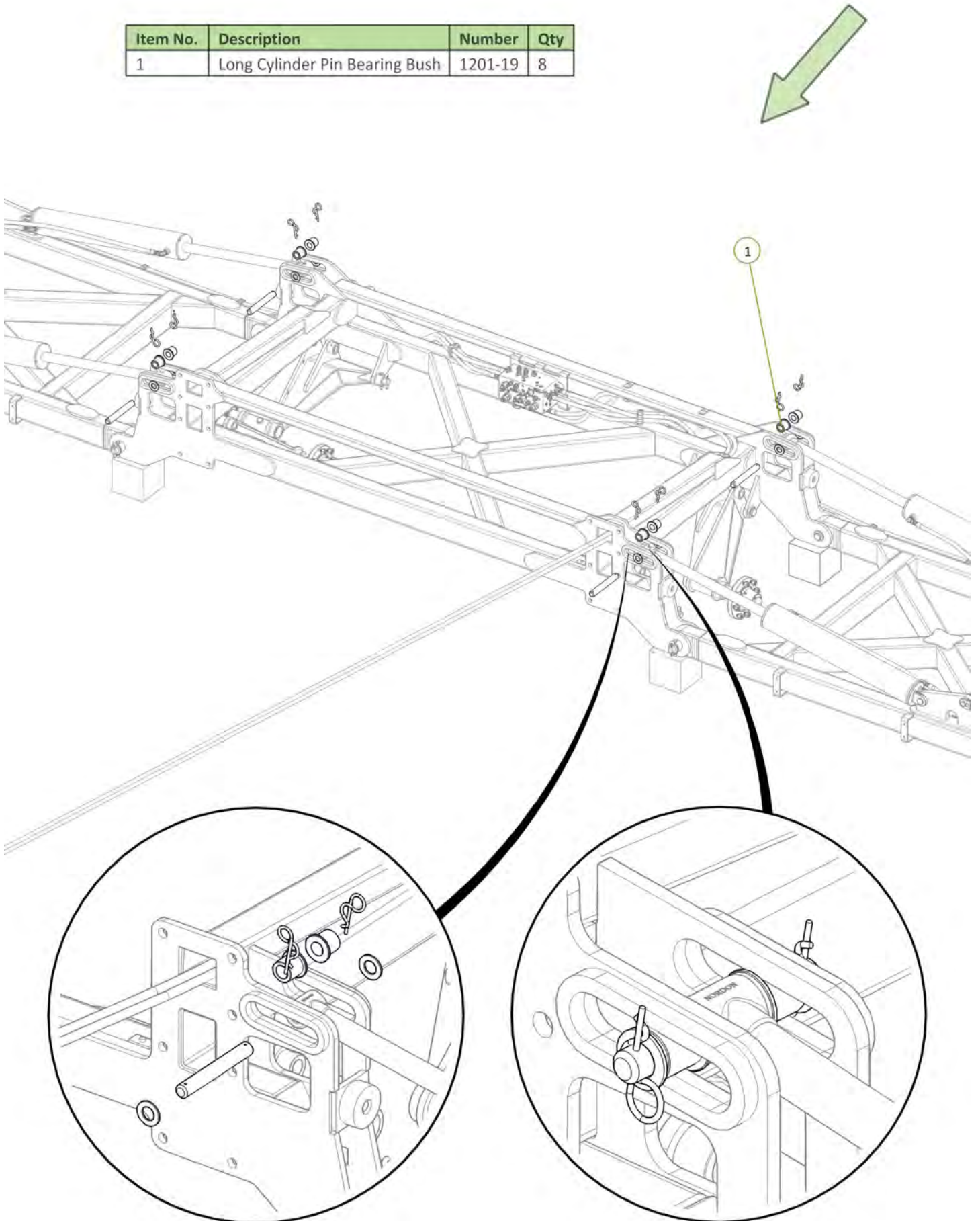

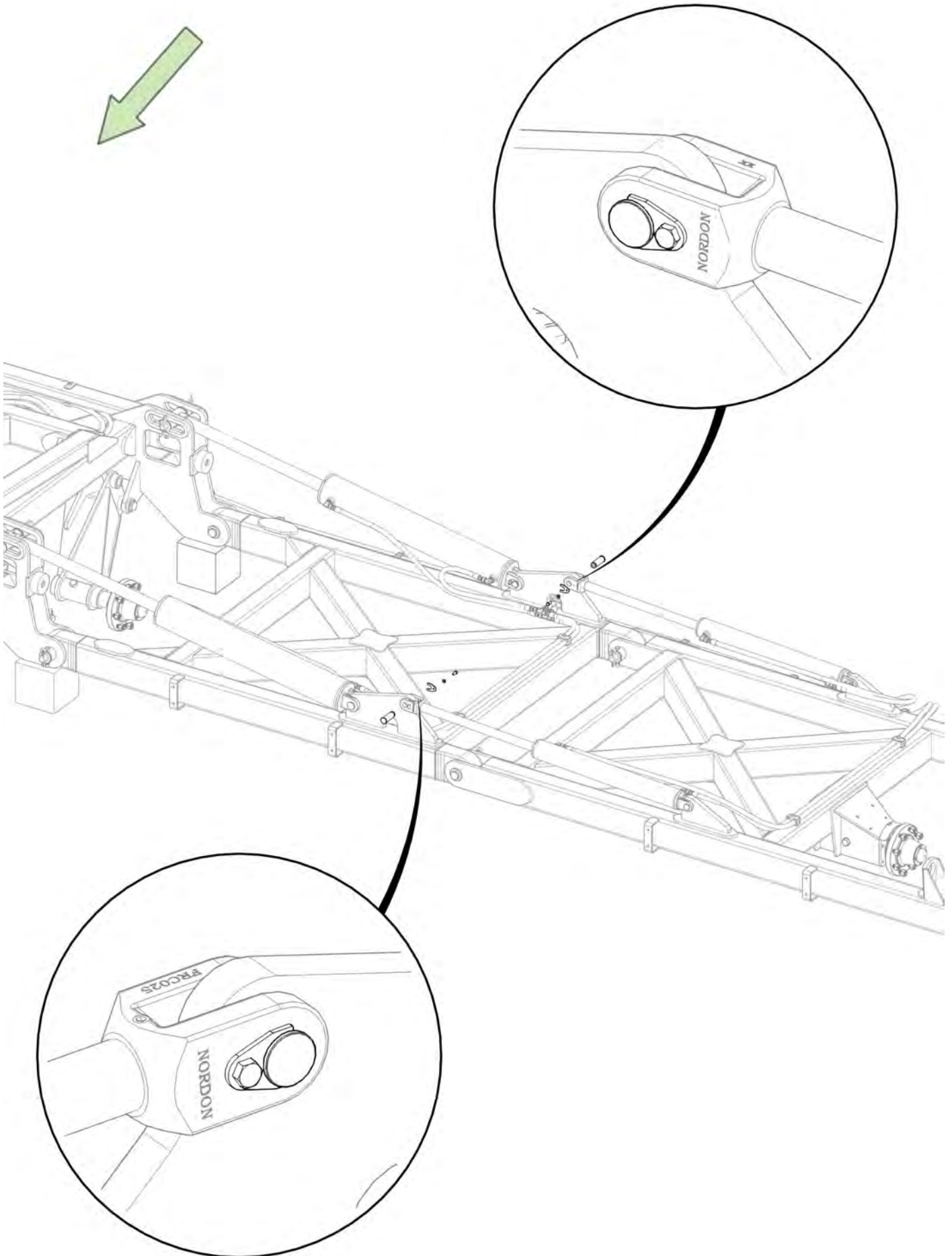

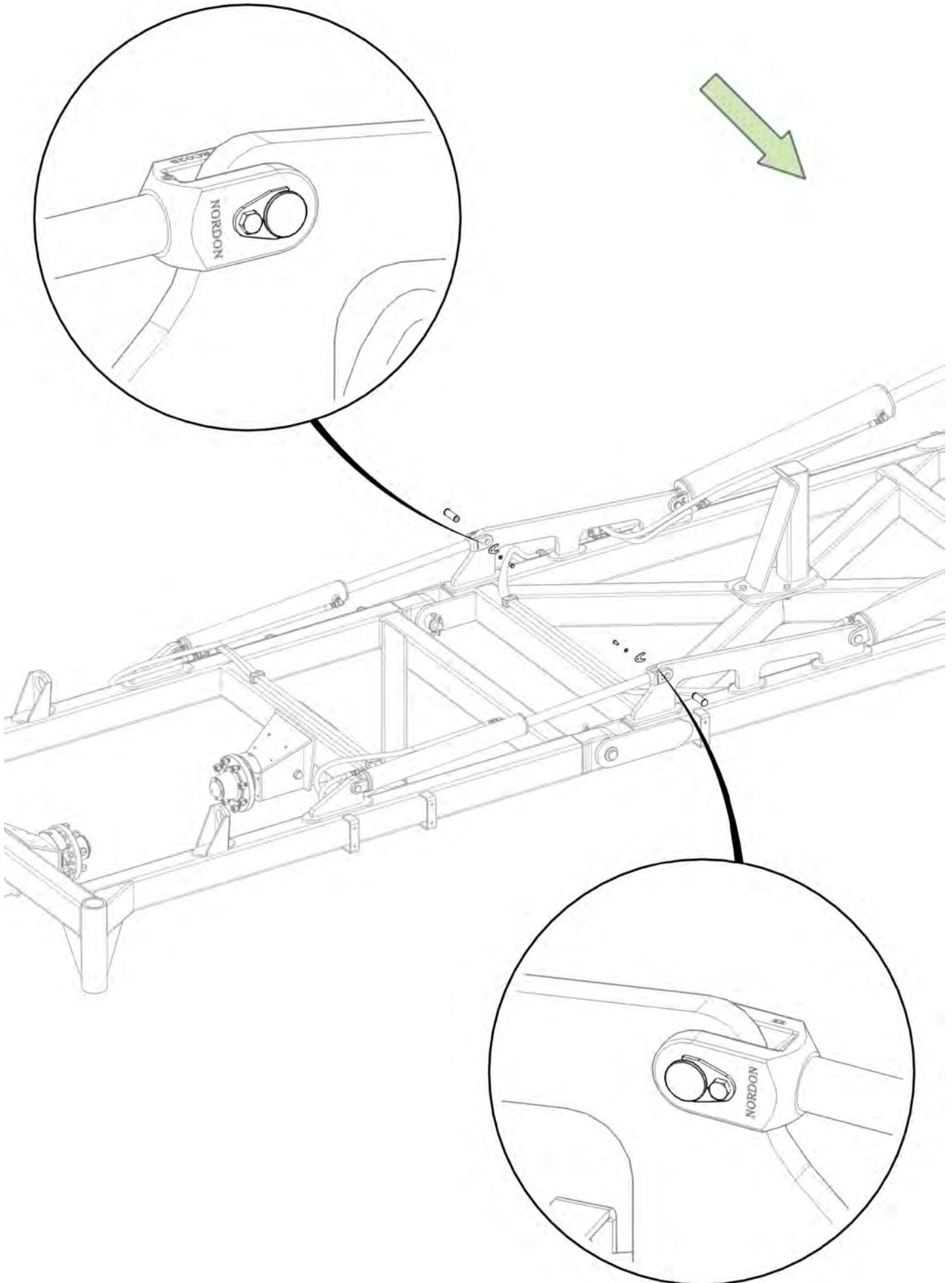

Item No.	Description	Number	Qty
1	Super Single LH Drop Leg No Clevis	0810-24SF	1
2	Super Single RH Drop Leg No Clevis	0810-25SF	1
3	LH Chain Adjusting Lug	0810-26	1
4	RH Chain Adjusting Lug	0810-27	1
5	M24 x 140 grade 8.8 zp Bolt	0211-24140	2
6	Nyloc Nut M24	0221-NYL24	2

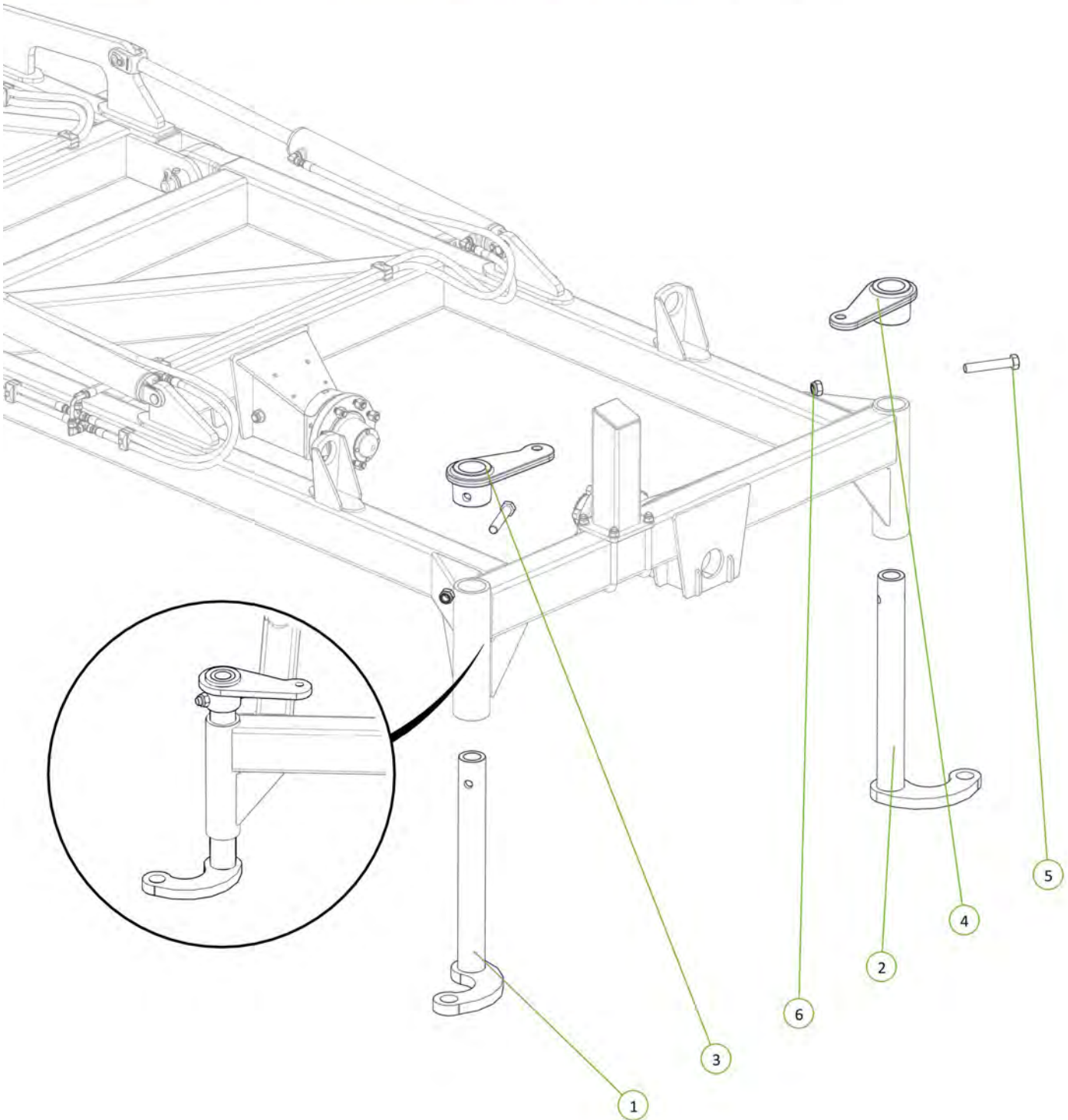

Item No.	Description	Number	Qty
1	Cast 25mm Spacing	0801-CS25	24
2	M10 x 30 grade 8.8 ZP Bolt	0211-1030	24
3	Nyloc Nut M10	0221-NYL10	24

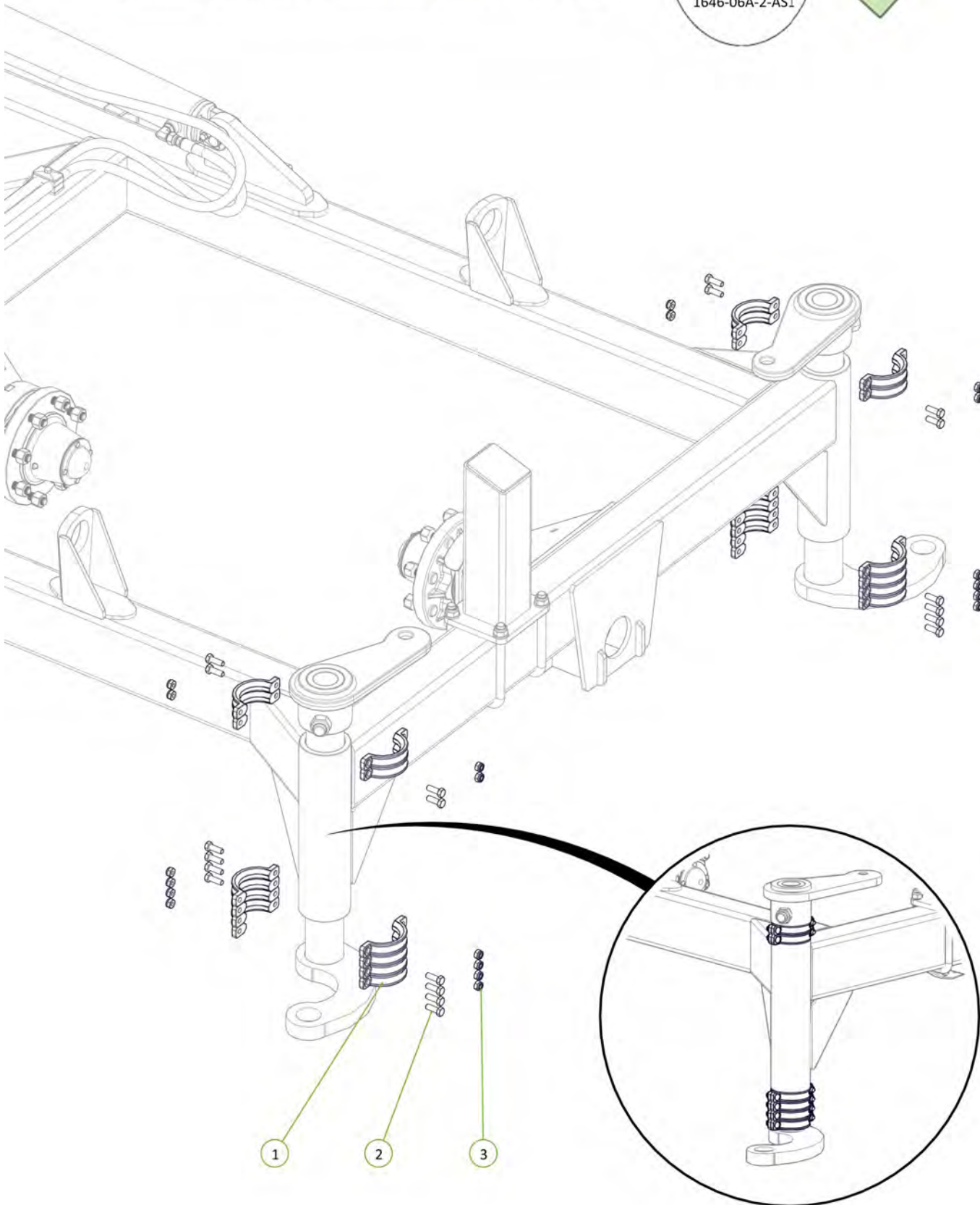

Item No.	Description	Number	Qty
1	Chain Tension Adjustor	0802-PCHTA	2
2	Heavy Duty Coil Spring 24mm	0801-K2455350	2
3	Tensioner Cup - Male	0801-KE0805-3	2
4	Female Spring Locator	0801-KE0805-4	2
5	Washer High Tensile 1 1/4"	0232-HT11-4	2

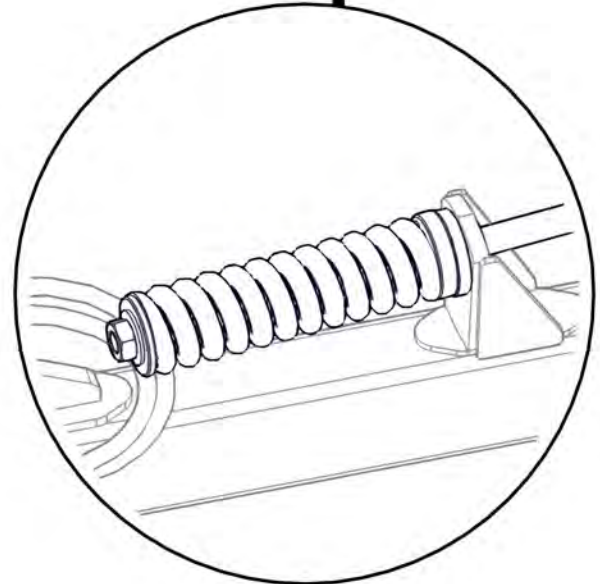
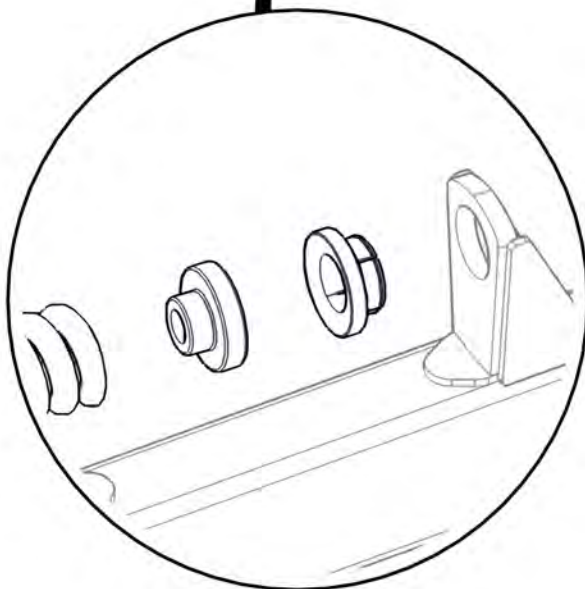
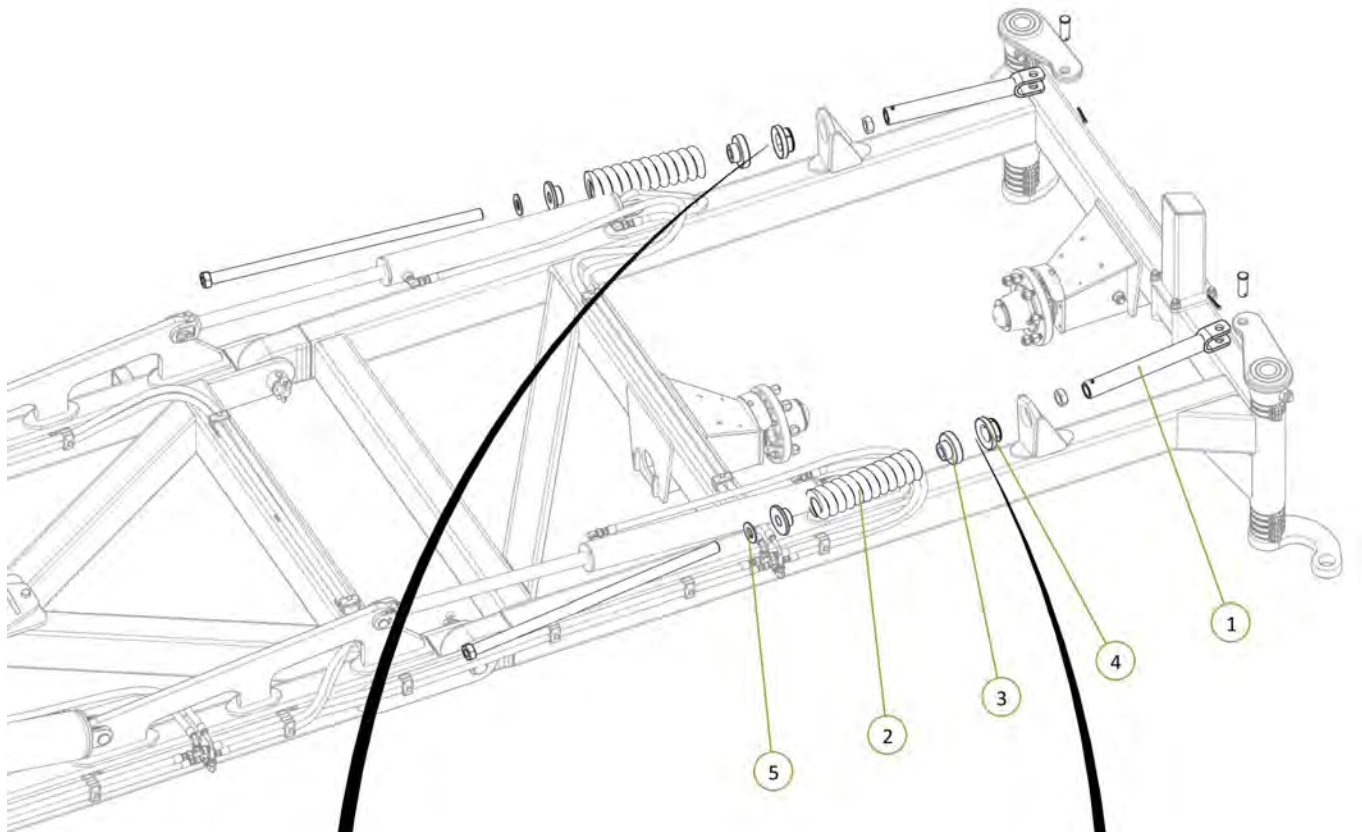

Item No.	Description	Number	Qty
1	Super Single LH Drop Leg No Clevis	0810-24SF	1
2	Super Single RH Drop Leg No Clevis	0810-25SF	1
3	LH Chain Adjusting Lug	0810-26	1
4	RH Chain Adjusting Lug	0810-27	1
5	M24 x 140 grade 8.8 zp Bolt	0211-24140	2
6	Nyloc Nut M24	0221-NYL24	2

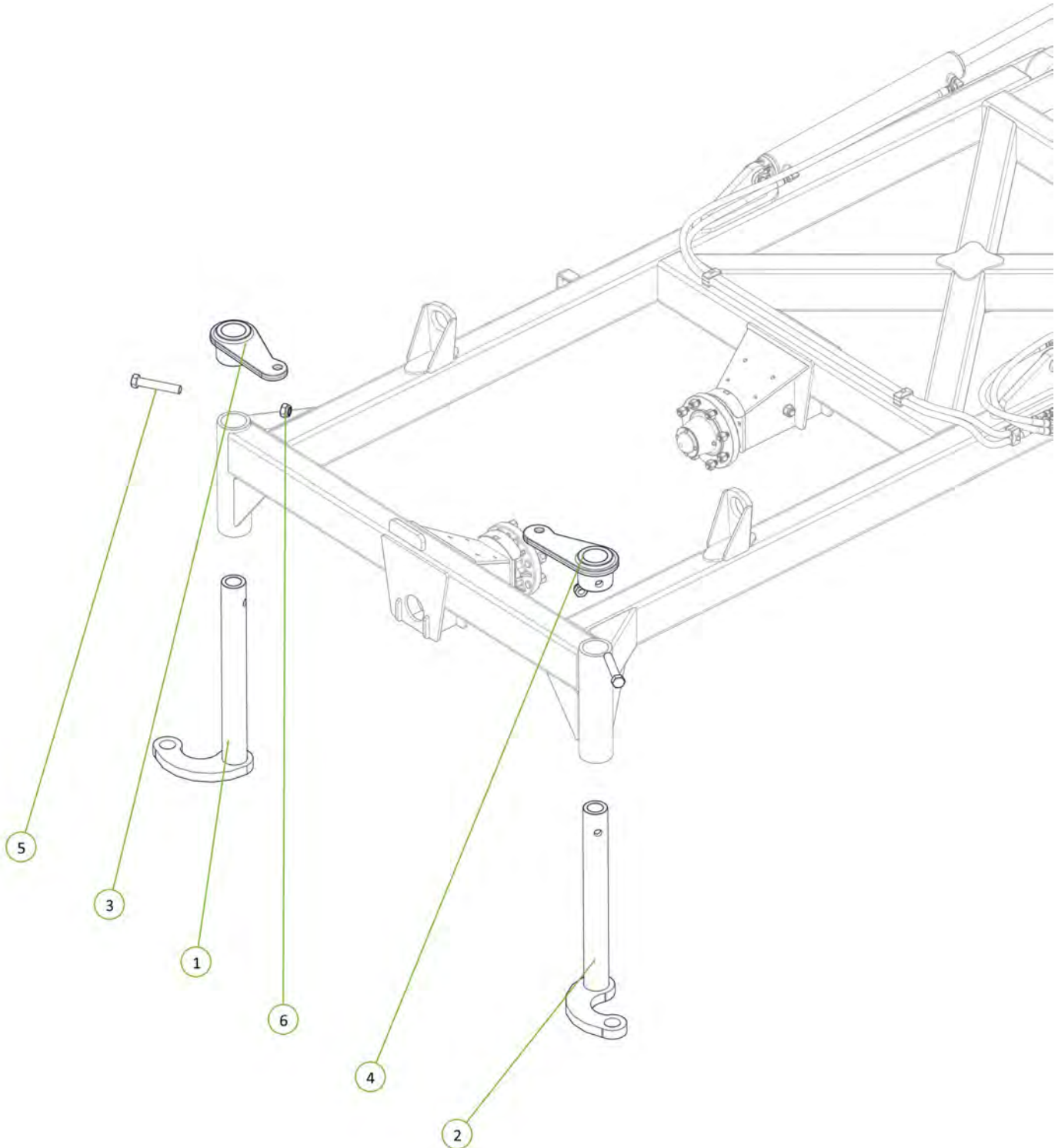

Item No.	Description	Number	Qty
1	Cast 25mm Spacing	0801-CS25	24
2	M10 x 30 grade 8.8 ZP Bolt	0211-1030	24
3	Nyloc Nut M10	0221-NYL10	24

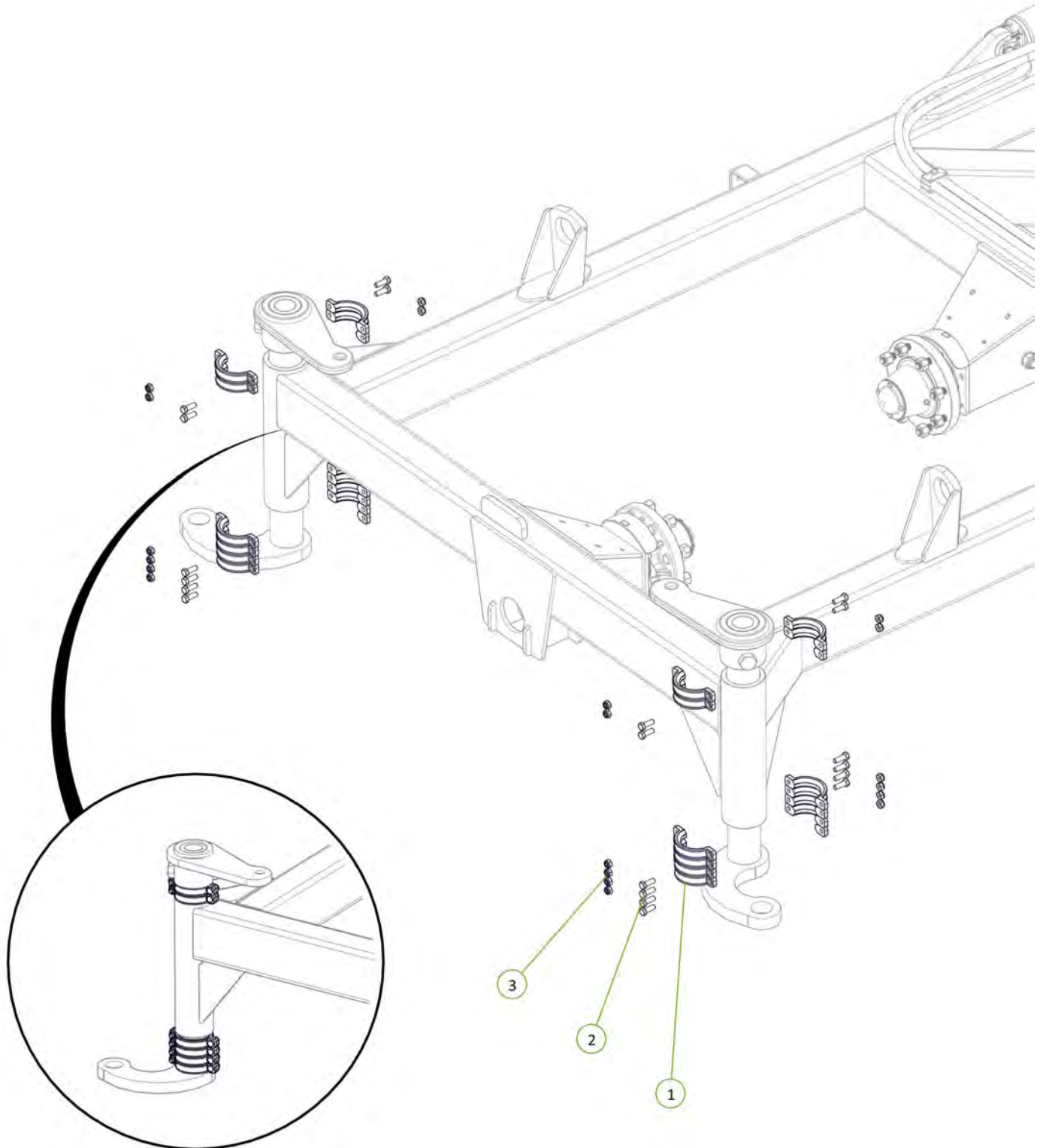

Item No.	Description	Number	Qty
1	Chain Tension Adjustor	0802-PCHTA	2
2	Heavy Duty Coil Spring 24mm	0801-K2455350	2
3	Tensioner Cup - Male	0801-KE0805-3	2
4	Female Spring Locator	0801-KE0805-4	2
5	Washer High Tensile 1 1/4"	0232-HT11-4	2

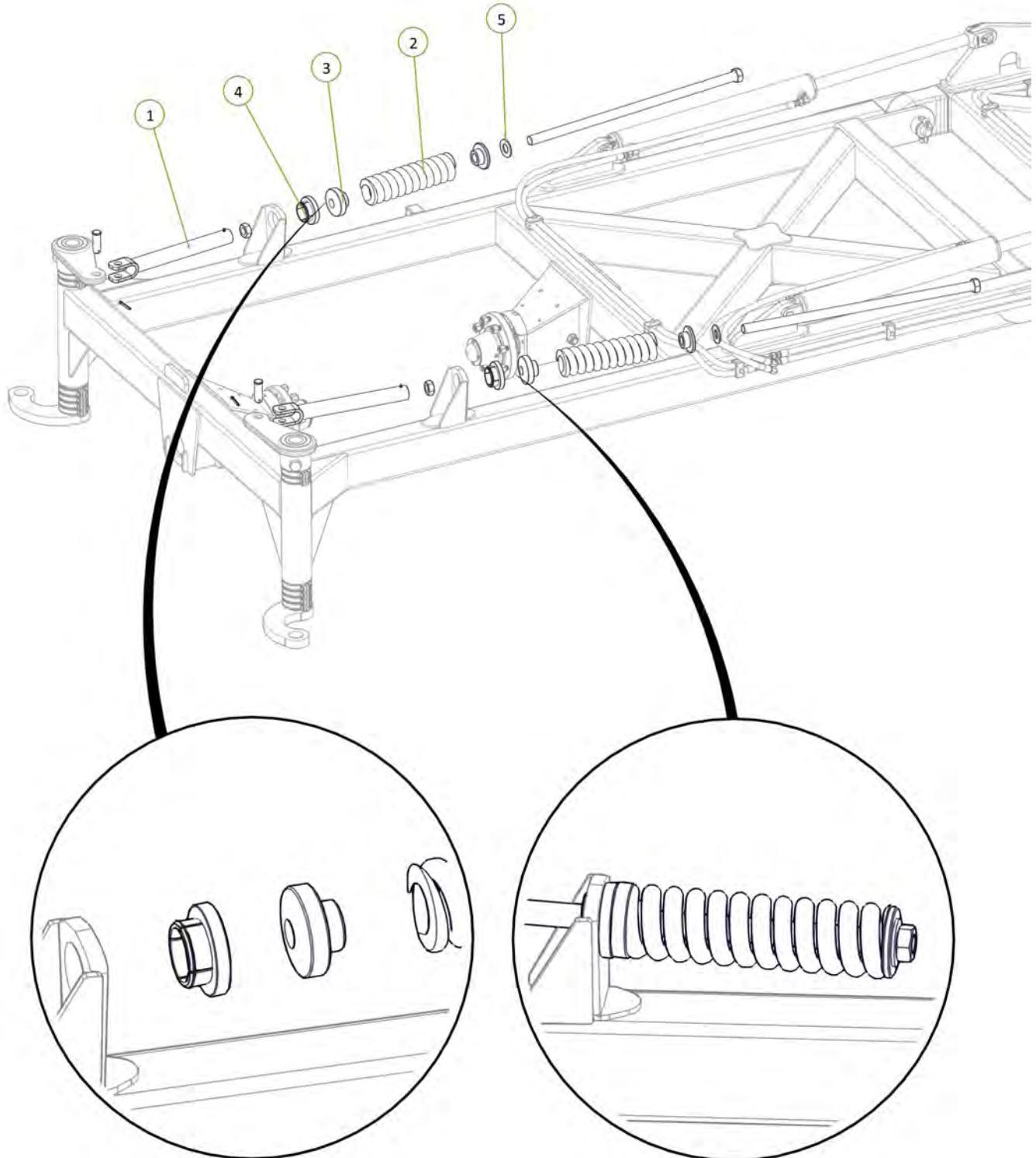

Item No.	Description	Number	Qty
1	Walking Axle Linkage	1610-33	2
2	M12 x 90 Class 8.8 ZP Bolt	0211-1290	4
3	Walking Axle Linkage Pivot Pin	1601-P38-220	4
4	1-1/2 ID x 1-1/4mm DU Bush	0113-24DU20	8
5	Nyloc Nut M12	0221-NYL12	4
6	Cotter Pin M13 x 63	0261-PINC1363	4

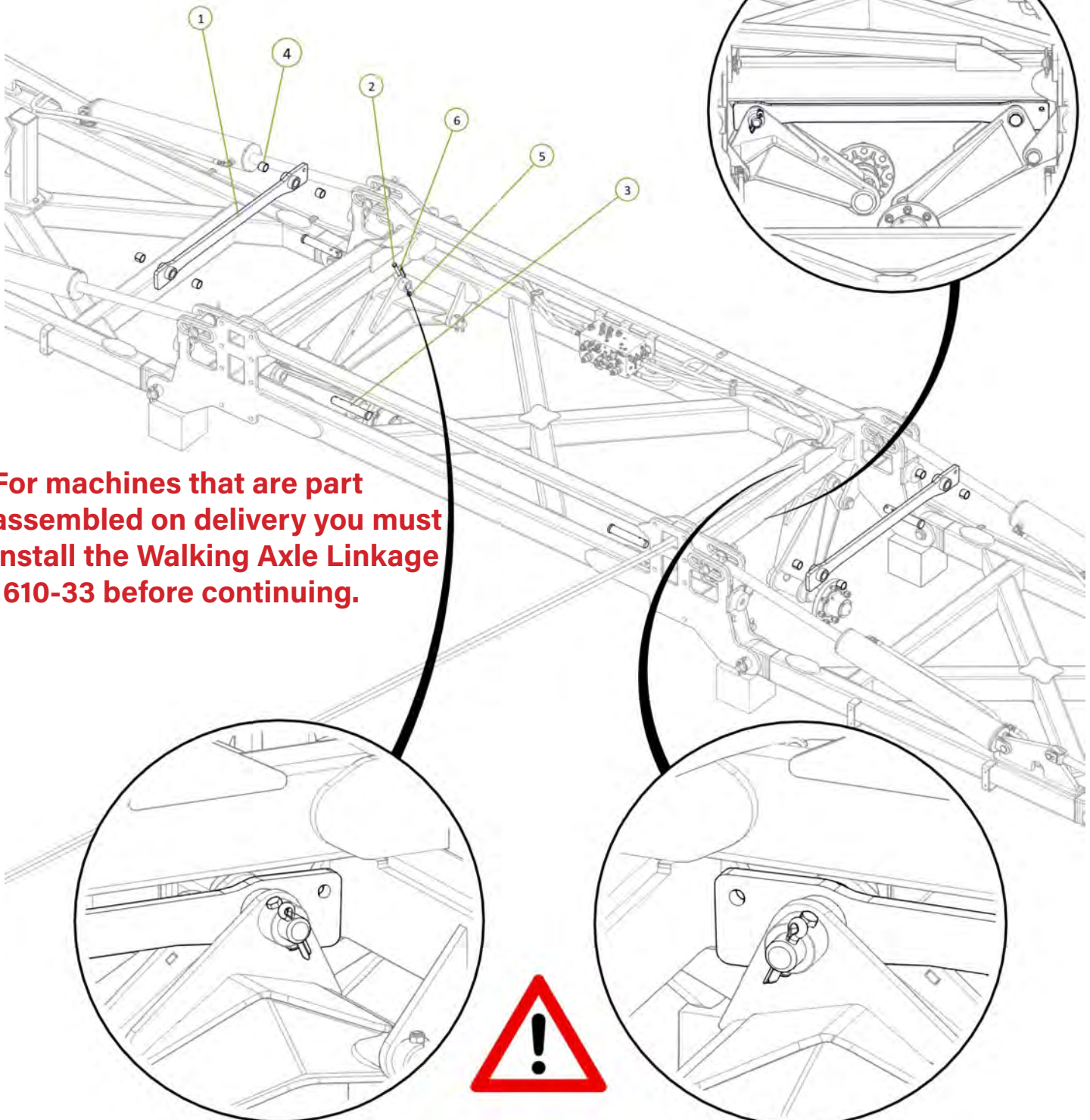

For machines that are part assembled on delivery you must install the Walking Axle Linkage 1610-33 before continuing.

Item No.	Description	Number	Qty
1	46' Main Pull - Nose	1646-02-01	1
2	46' Main Pull Right Hand Side	1646-02-02	1
3	46' Main Pull Left Hand Side	1646-02-03	1
4	46' Main Pull Brace	1646-02-04	1
5	M24 x 75 grade 8.8 zp Bolt	0211-2475	20
6	M16 x 50 grade 8.8 zp Bolt	0211-1650	8
7	Nyloc Nut M24	0221-NYL24	20
8	Nyloc Nut M16	0221-NYL16	8
9	Washer Flat M24	0231-F24	40
10	Washer Flat M16	0231-F16	16

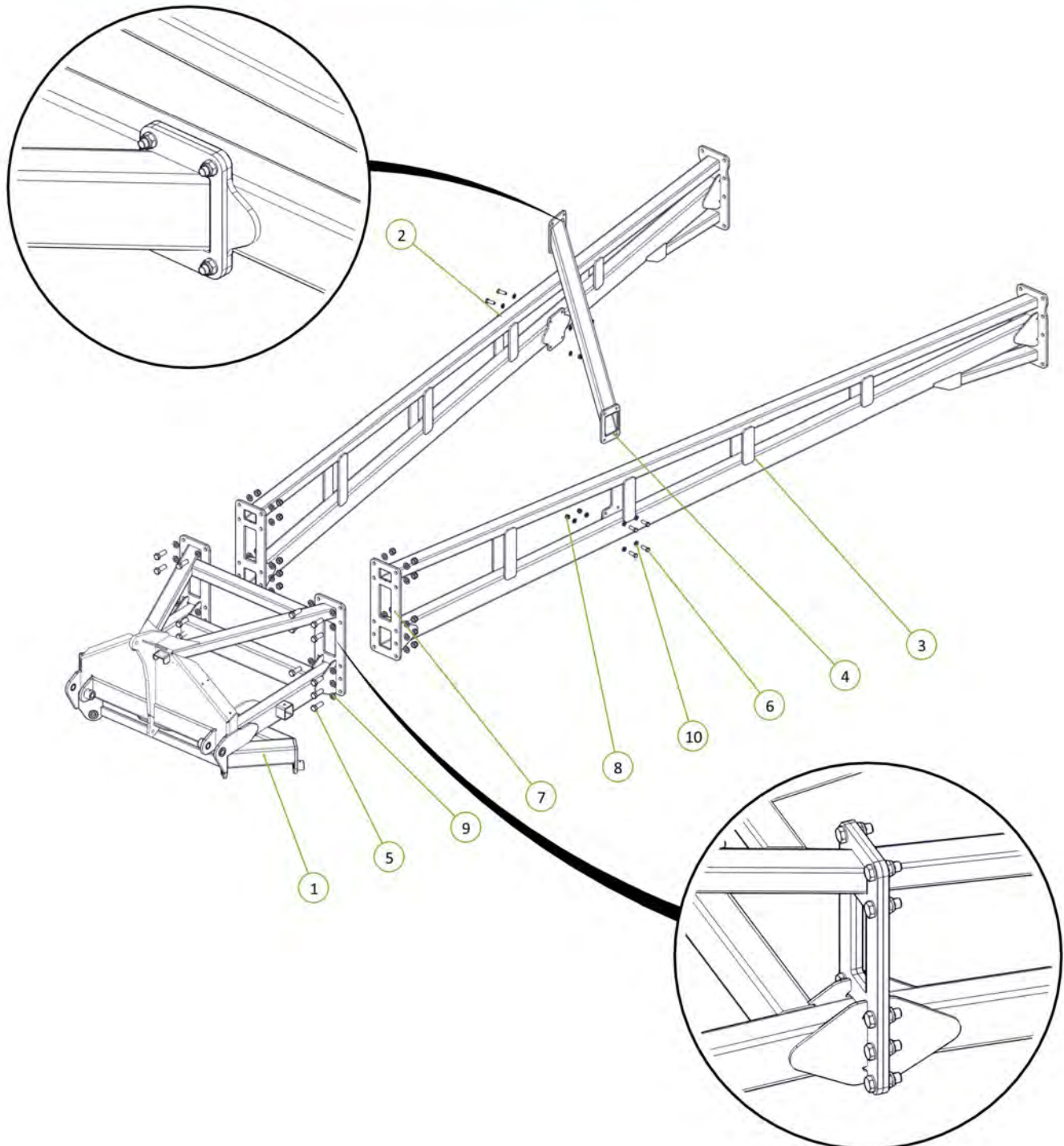

Item No.	Description	Number	Qty
1	M24 x 75 grade 8.8 zp Bolt	0211-2475	16
2	Nyloc Nut M24	0221-NYL24	16
3	Washer Flat M24	0231-F24	32

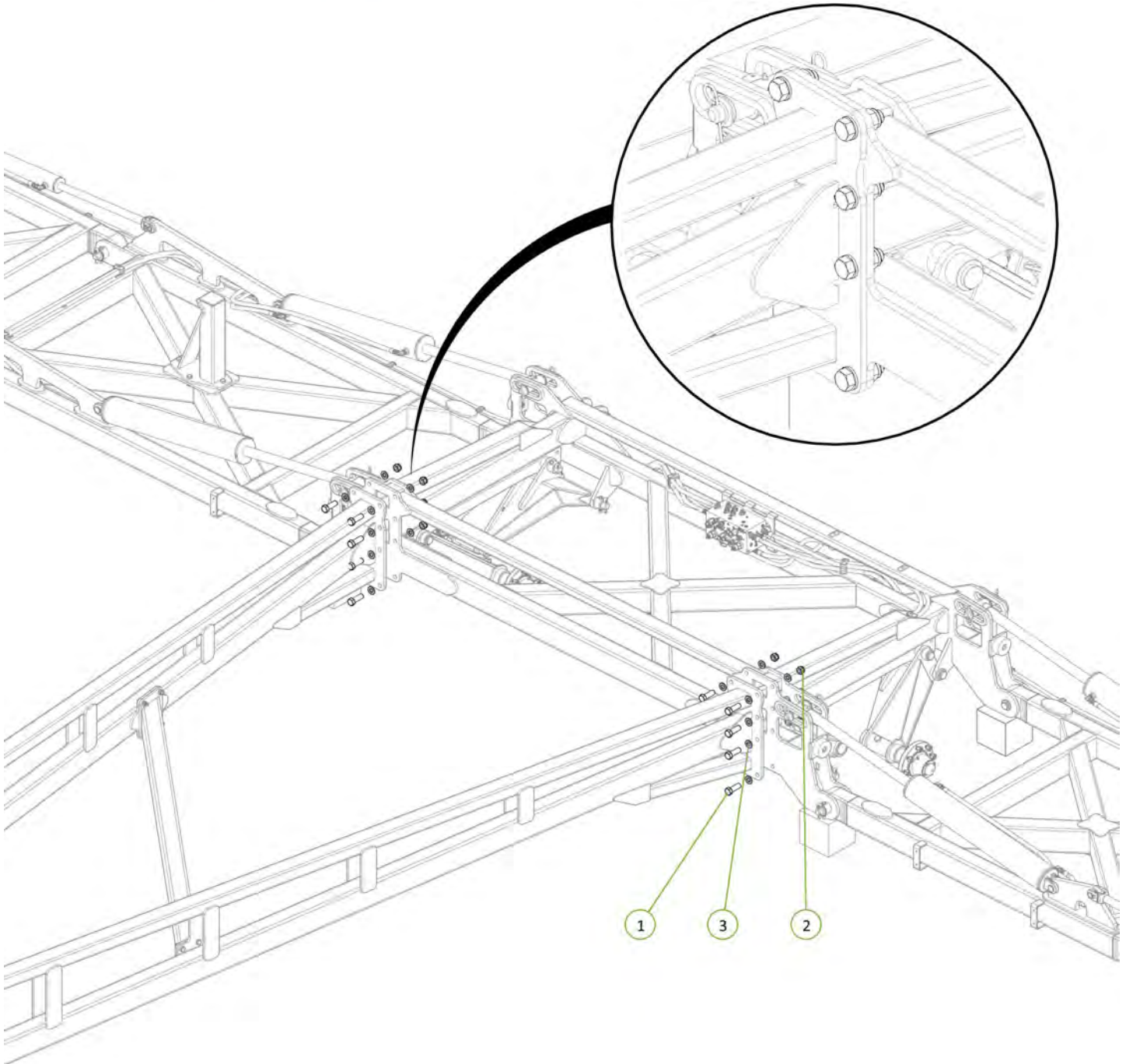
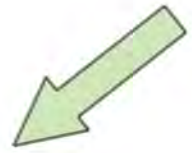

Item No.	Description	Number	Qty
1	400/55-22.5 Tyre on 8 on 8" PCD Rim (Right Hand)	0751-400-55-22.5TR-R	4
2	400/55-22.5 Tyre on 8 on 8" PCD Rim (Left Hand)	0751-400-55-22.5TR-L	4

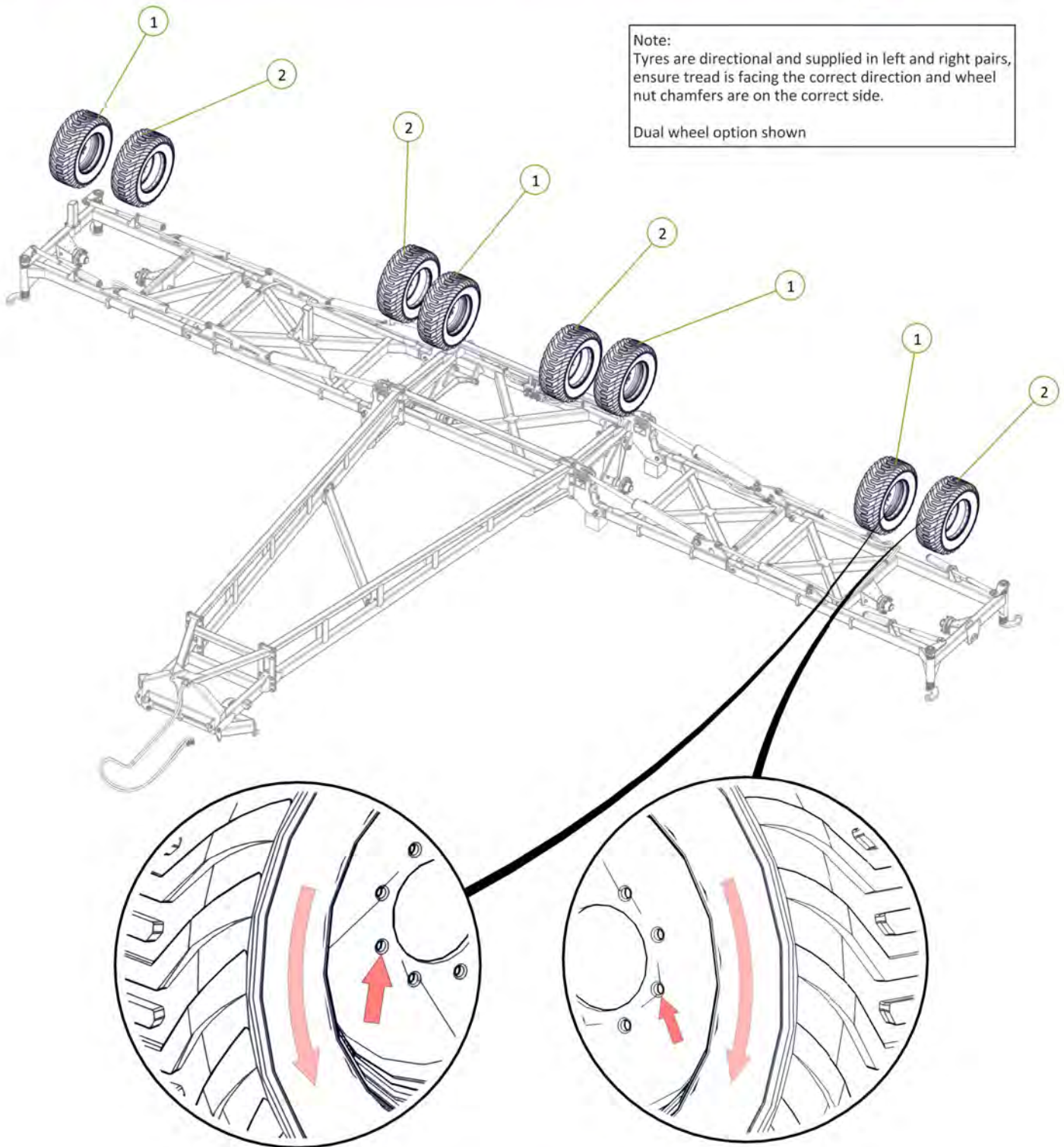

Note:
Tyres are directional and supplied in left and right pairs, ensure tread is facing the correct direction and wheel nut chamfers are on the correct side.

Dual wheel option shown

Torque wheel nuts to 100ft-lb / 140Nm

Item No.	Description	Number	Qty
1	US4t Heavy Duty Jack inc Handle	0810-37-US	1
2	Jack Pin	0801-B3077	1

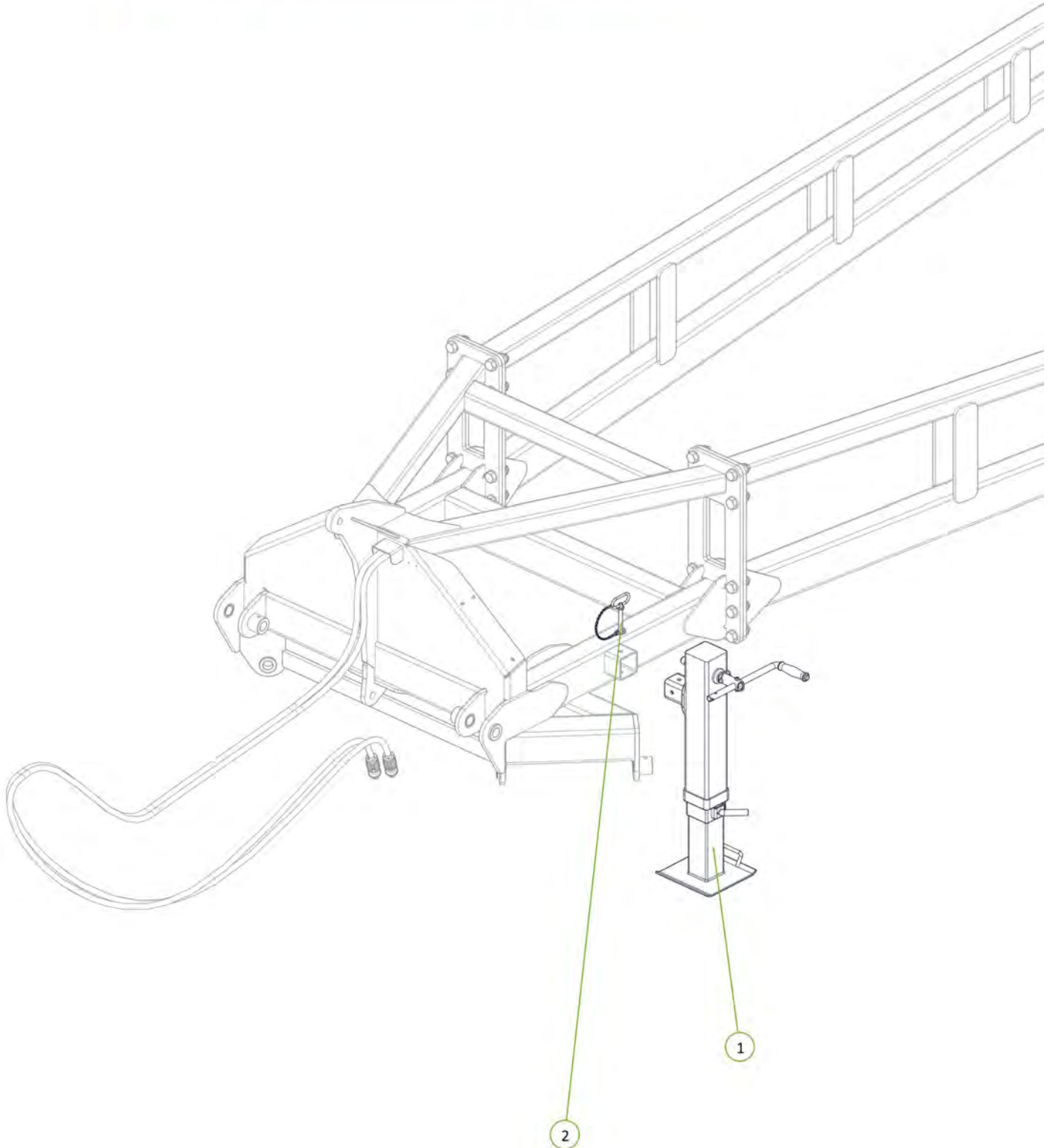

Item No.	Description	Number	Qty
1	Tractor to Sequence Valve EXT2 Port Fitted With Yellow EXT Decal	H46-2-03-YE-EXT2	1
2	Tractor to Sequence Valve RTC2 Port Fitted With Yellow RTC Decal	H46-2-04-YR-RCT2	1

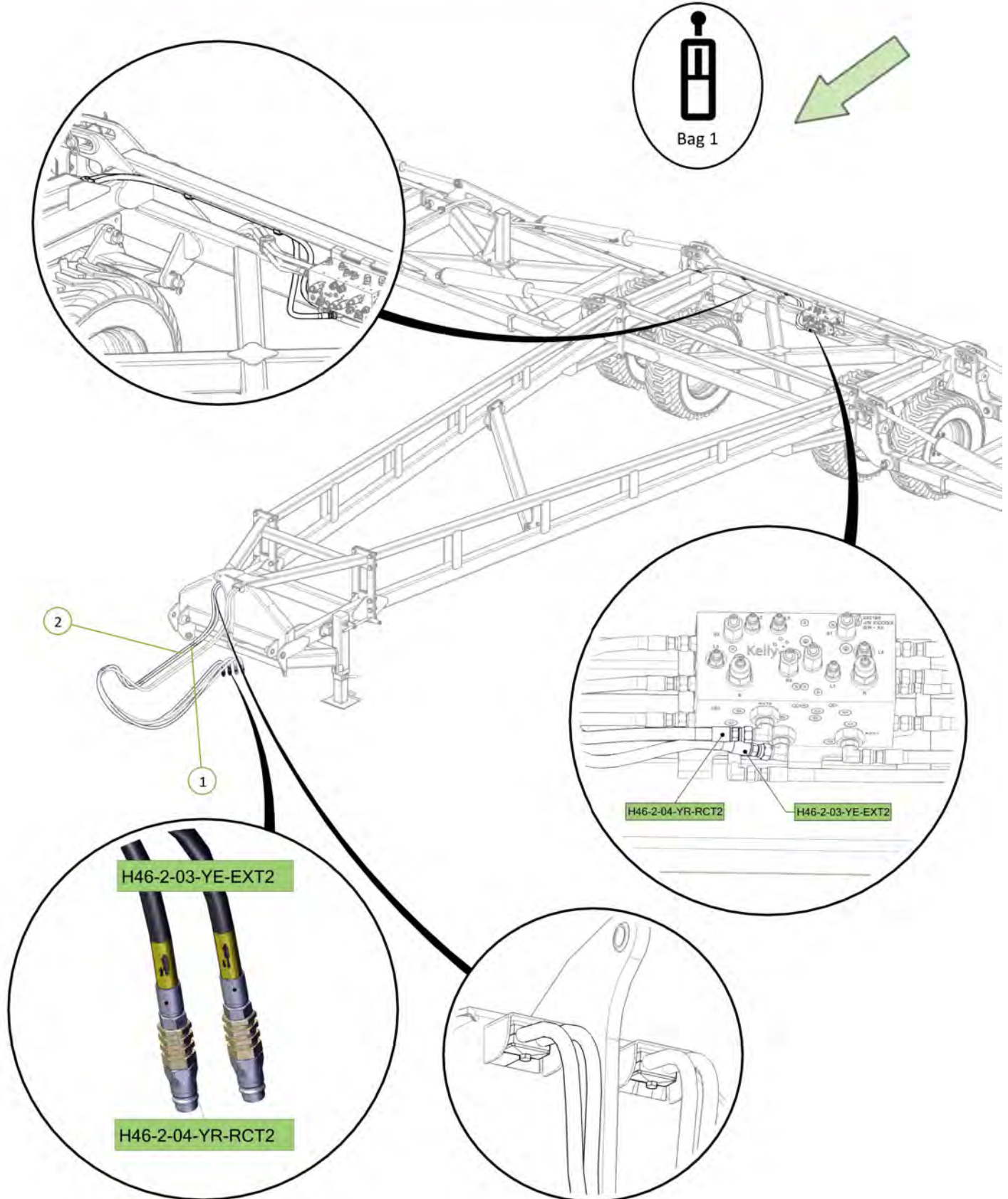

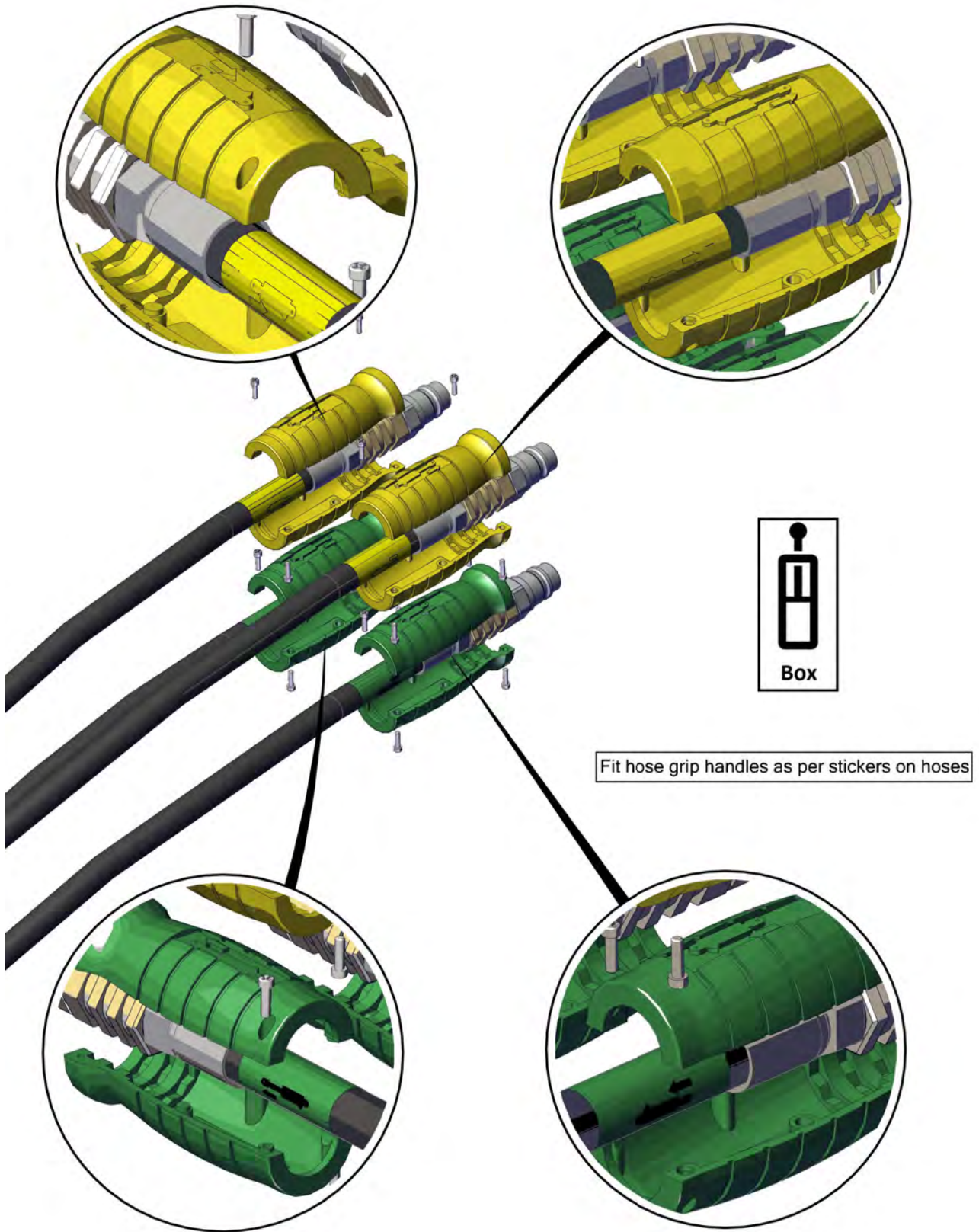

Item No.	Description	Number	Qty
1	46' Rear A-Frame	1646-03-11	1
2	46' Rear A-Frame Right Hand Side	1646-03-12	1
3	46' Rear A-Frame Left Hand Side	1646-03-13	1
4	46' Rear A-Frame Front Brace	1646-03-14	1
5	46' Rear A-Frame Cross Brace	1646-03-15	1
6	M20 x 65 grade 8.8 ZP Bolt	0211-2065	15
7	Nyloc Nut M20	0221-NYL20	15
8	M16 x 50 grade 8.8 zp Bolt	0211-1650	16
9	Nyloc Nut M16	0221-NYL16	16
10	35 ID x 30mm DU Bush	0113-MB3530DU	4
11	Washer Flat M16	0231-F16	32
12	Washer Flat M20	0231-F20	30

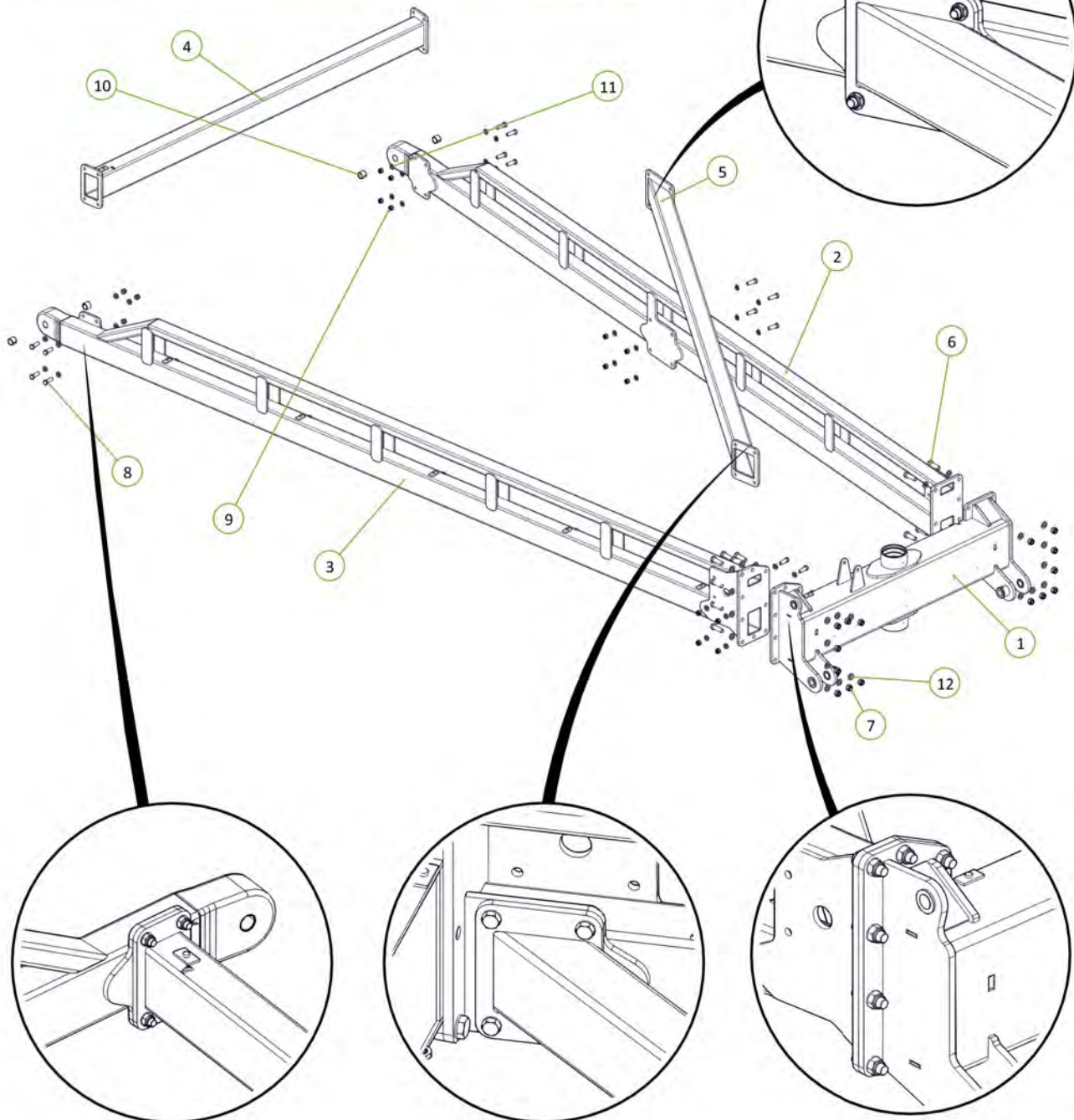

Item No.	Description	Number	Qty
1	Jockey Wheel 90mm Shaft 70mm Axles	1610-13-90	1
2	Plain Spherical Bearing 90mm	0113-GE90DO-2RSP	2
3	Circlip Internal 130mm	0171-J130	2
4	Circlip External 90mm	0172-D1400-90	1
5	TC Seal 90mm x 135mm x 12mm	0121-TC12906	1
6	TC Seal 110mm x 140mm x 12mm	0121-TC12700	1
7	Grease Nipple 1/4" UNF 45°	0181-GN1/445	2

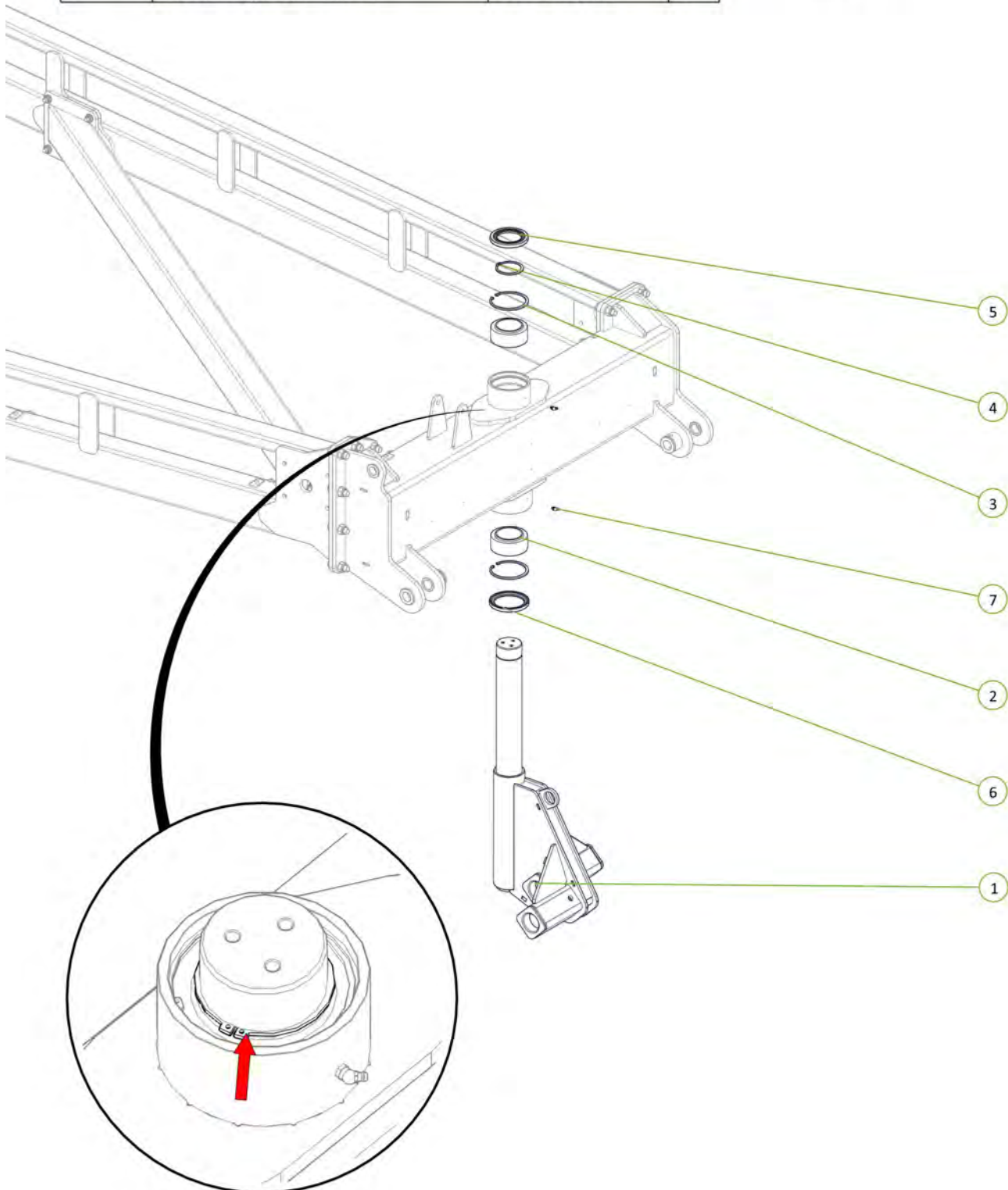

Item No.	Description	Number	Qty
1	Brake Disc	1600-405	1
2	M12 x 24 Wheel Bolt	0216-WB1224	3

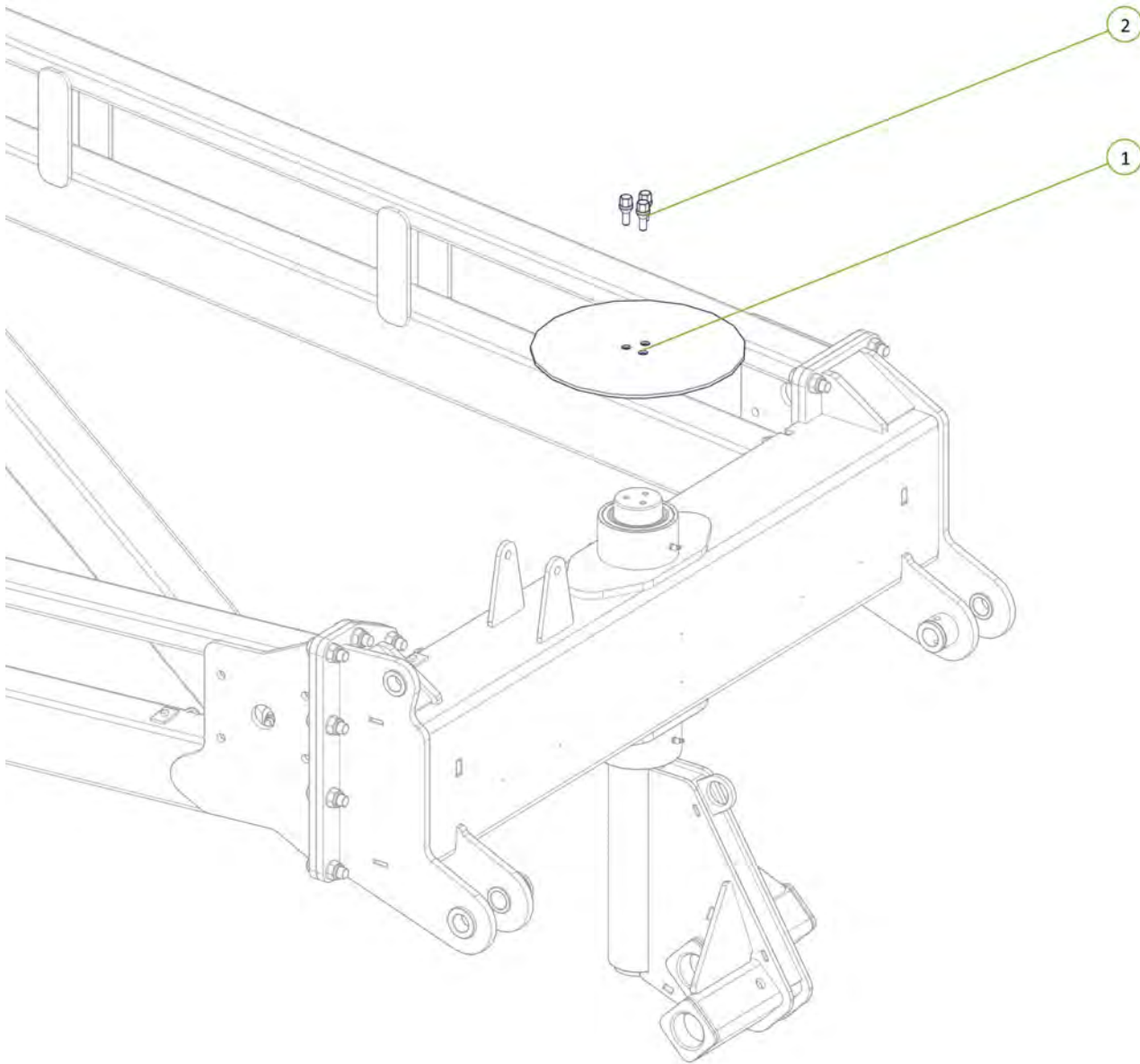

Torque wheel bolts to 65ft-lb / 88Nm

Item No.	Description	Number	Qty
1	Jockey Wheel Brake Caliper	0810-12CAL	1
2	Brake Compression Spring	0801-KE009	1
3	Brake Spring Indicator	0800-772	1
4	M16 x 150 Class 8.8 ZP Bolt	0211-16150	1
5	M16 x 160 Class 8.8 ZP Bolt	0211-16160	1
6	Nyloc Nut M16	0221-NYL16	1
7	Washer Flat M16	0231-F16	2
8	Washer Square M16 x 50 x 5	0231-SQ16505	1

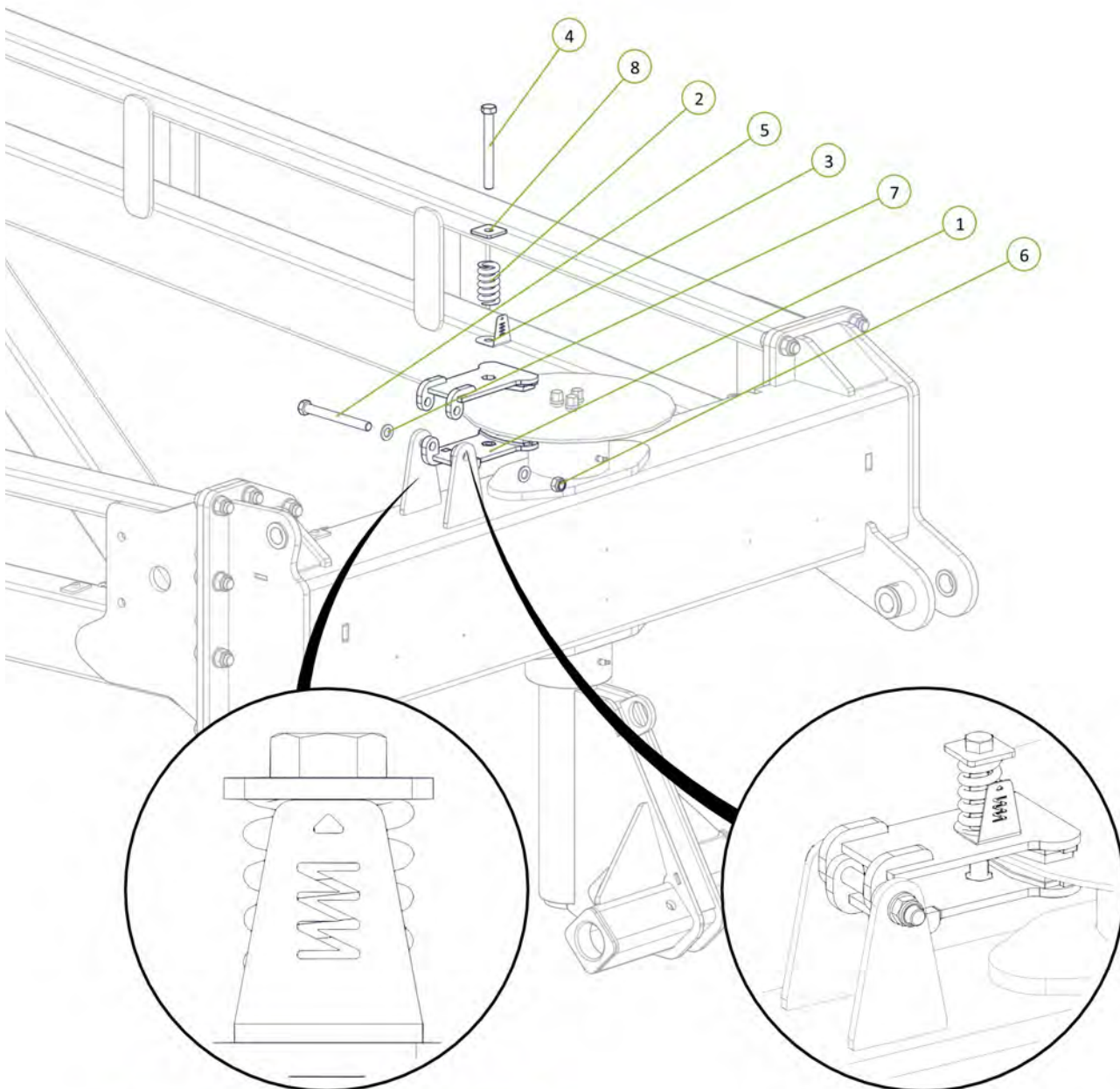

Compress spring to top of indicator as shown

Item No.	Description	Number	Qty
1	2.75"R C/W 6 tonne 8 on 8" PCD Complete Assembly inc GS	0733-LG6080067	2
2	M20 x 140 Class 8.8 ZP Bolt	0211-20140	2
3	Nyloc Nut M20	0221-NYL20	2
4	Washer Flat M20	0231-F20	4

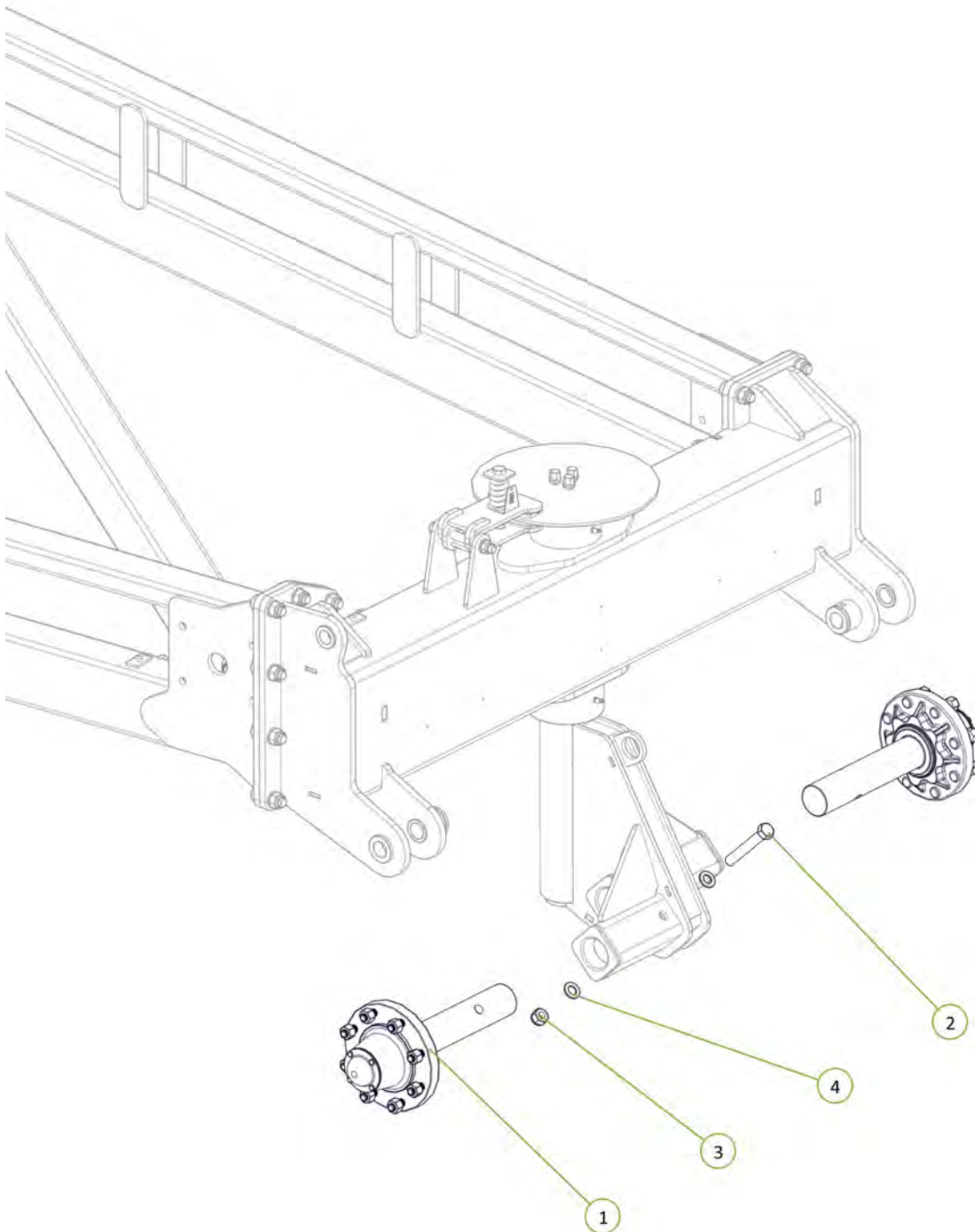

Item No.	Description	Number	Qty
1	31/13.5-15 Tire and Rim Assembly	0751-31-13.5-15	2

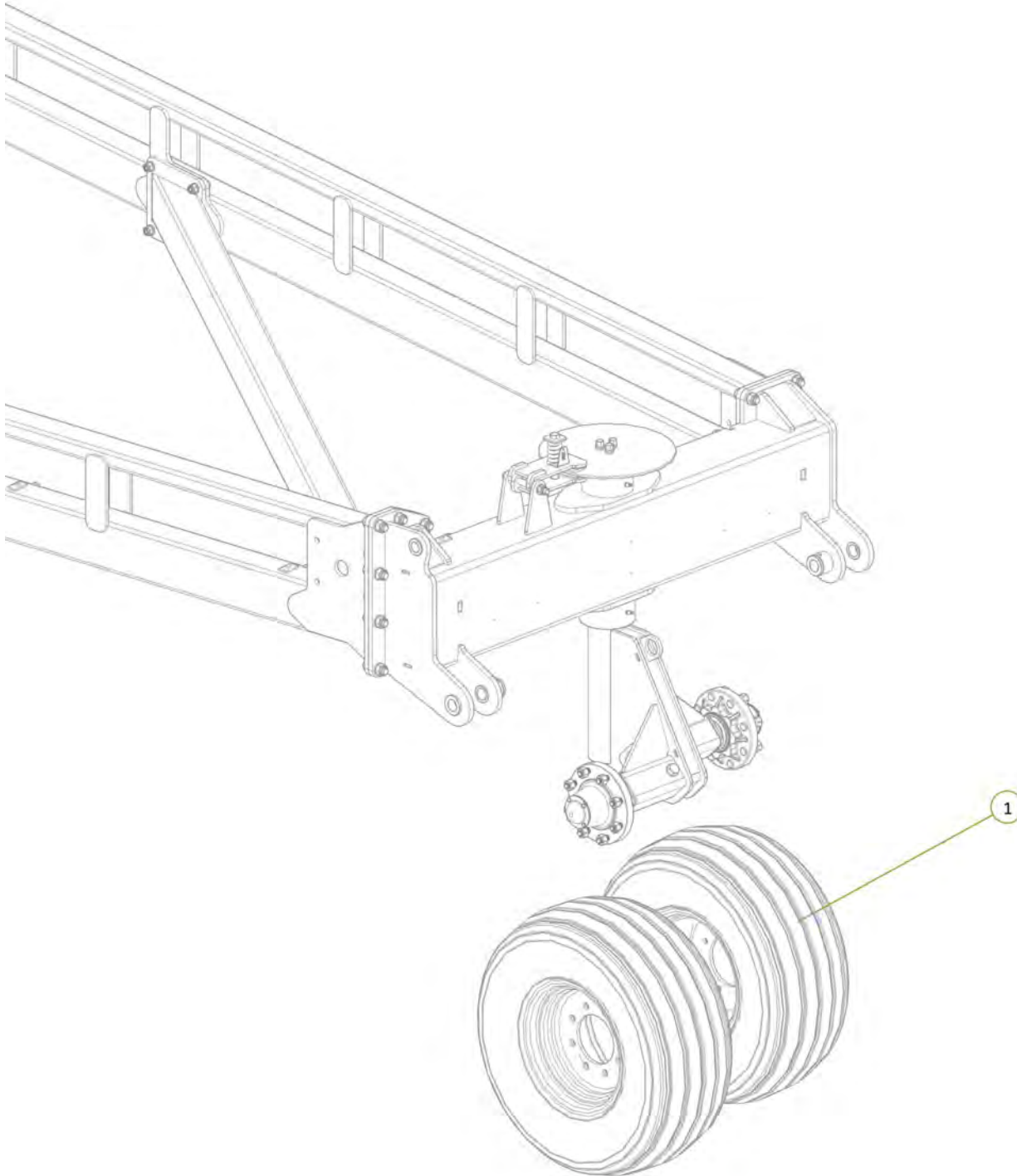

Torque wheel nuts to 100ft-lb / 140Nm

Item No.	Description	Number	Qty
1	PCH Wing Pivot Pin	0801-10-08-235	2
2	M12 x 90 Class 8.8 ZP Bolt	0211-1290	2
3	Cotter Pin M13 x 63	0261-PINC1363	2
4	Nyloc Nut M12	0221-NYL12	2

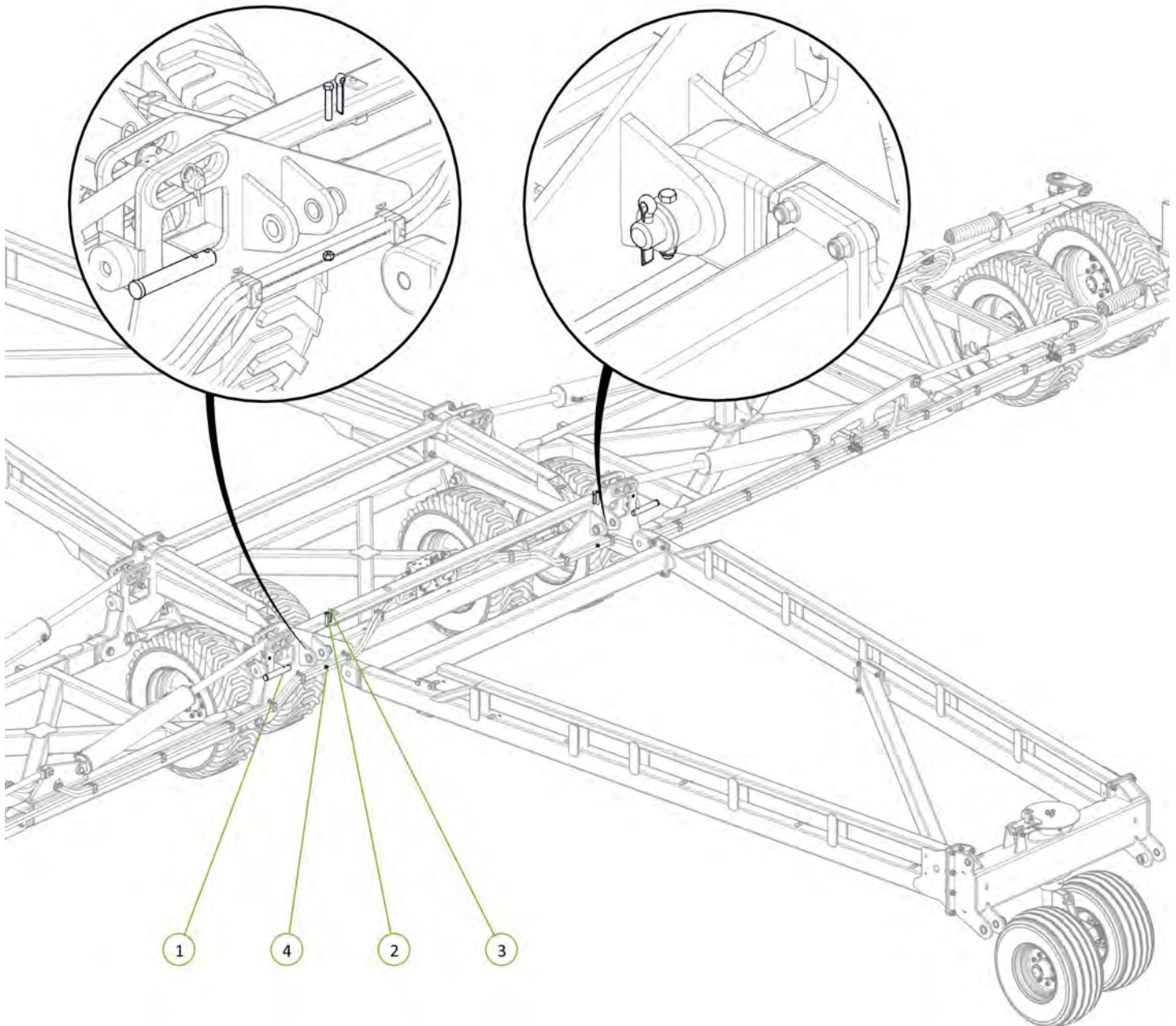

Item No.	Description	Number	Qty
1	Rear Tail	1510-40S-2	1
2	35 ID x 30mm DU Bush	0113-MB3530DU	4
3	M12 x 90 Class 8.8 ZP Bolt	0211-1290	2
4	Nyloc Nut M12	0221-NYL12	2
5	Cotter Pin M13 x 63	0261-PINC1363	2
6	PCH Wing Pivot Pin	0801-10-08-235	2

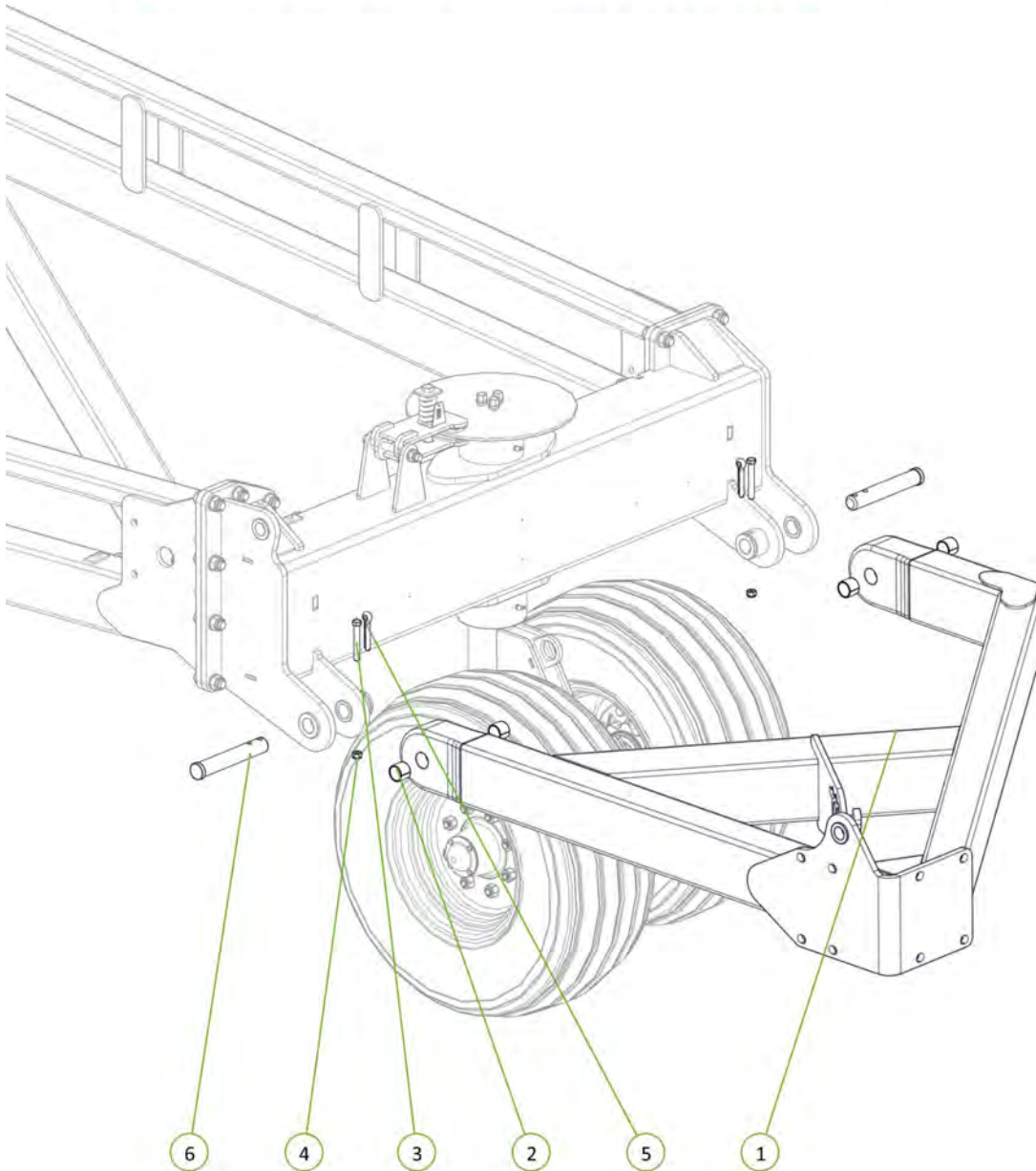

Item No.	Description	Number	Qty
1	4" Bore 24" Stroke 1.75" Rod Hydraulic Cylinder	0311-424	1

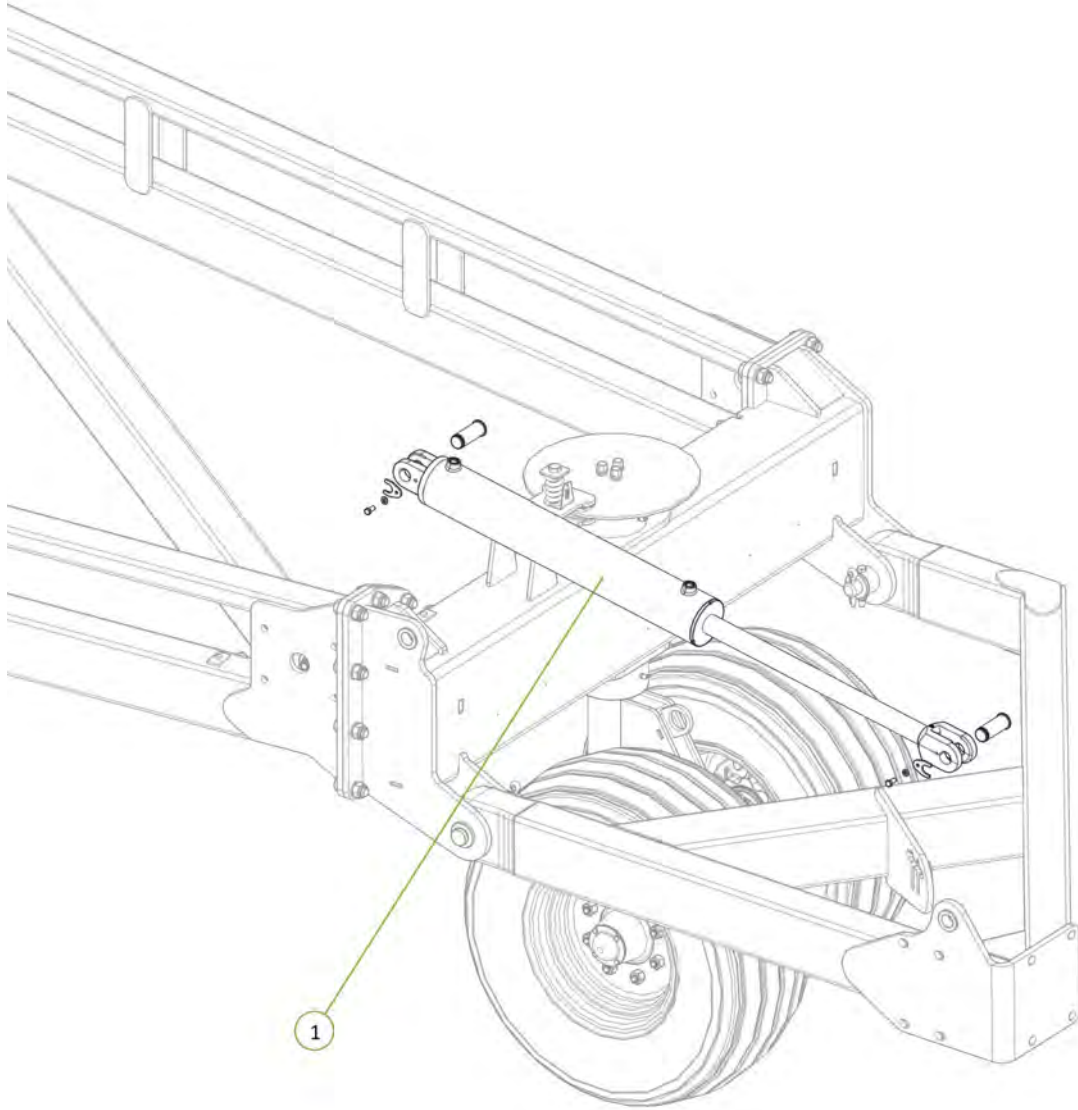

Item No.	Description	Number	Qty
1	3/4" JIC Male 3/4" UN O Ring Male 90° Elbow	0323-S91-1212	2

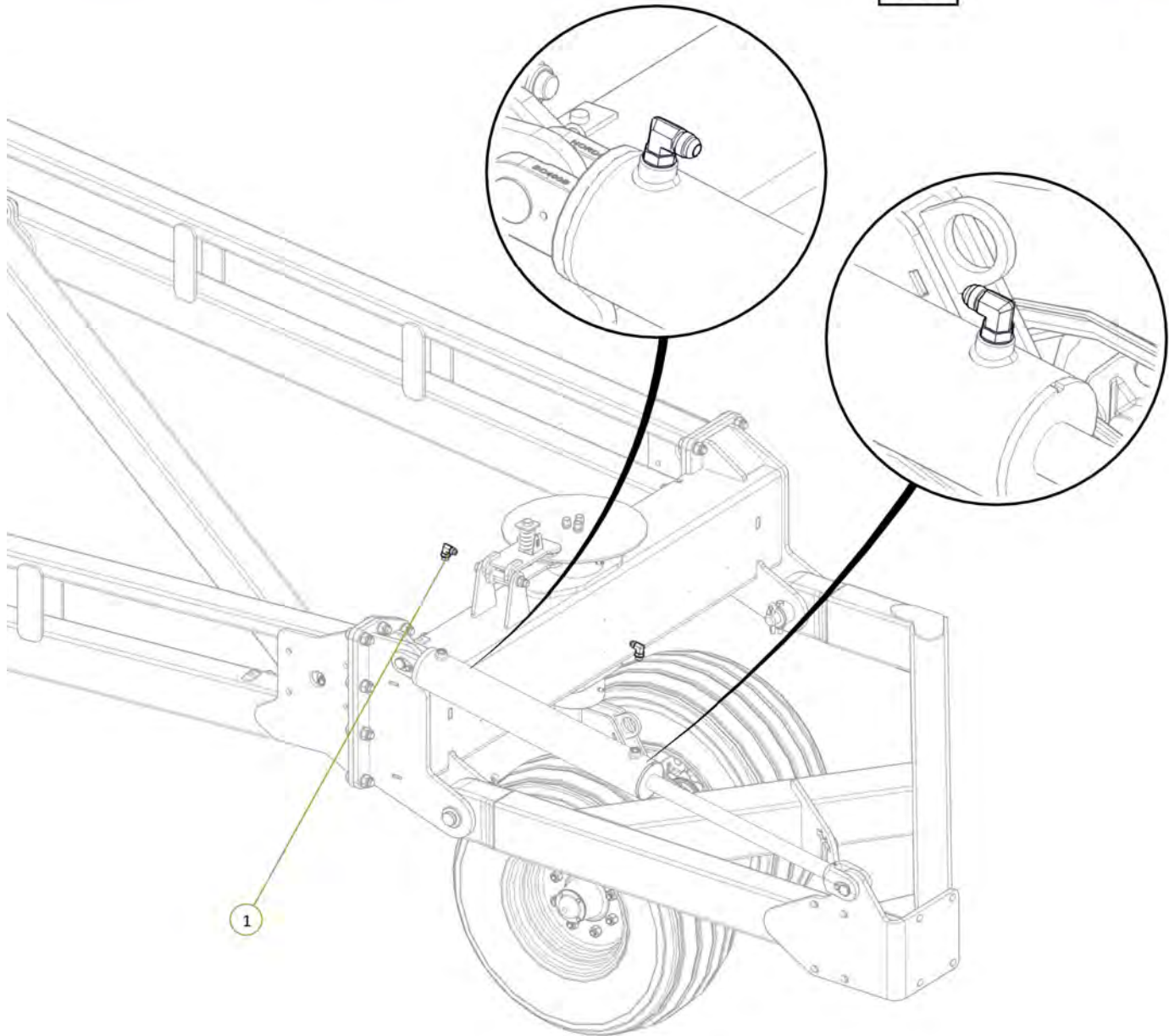
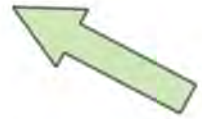
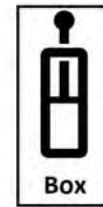

Item No.	Description	Number	Qty
1	Sequence Valve TE1 Port to Tail Cylinder Extend Port	H46-2-09	1
2	Sequence Valve TR1 Port to Tail Cylinder Retract Port	H46-2-10	1

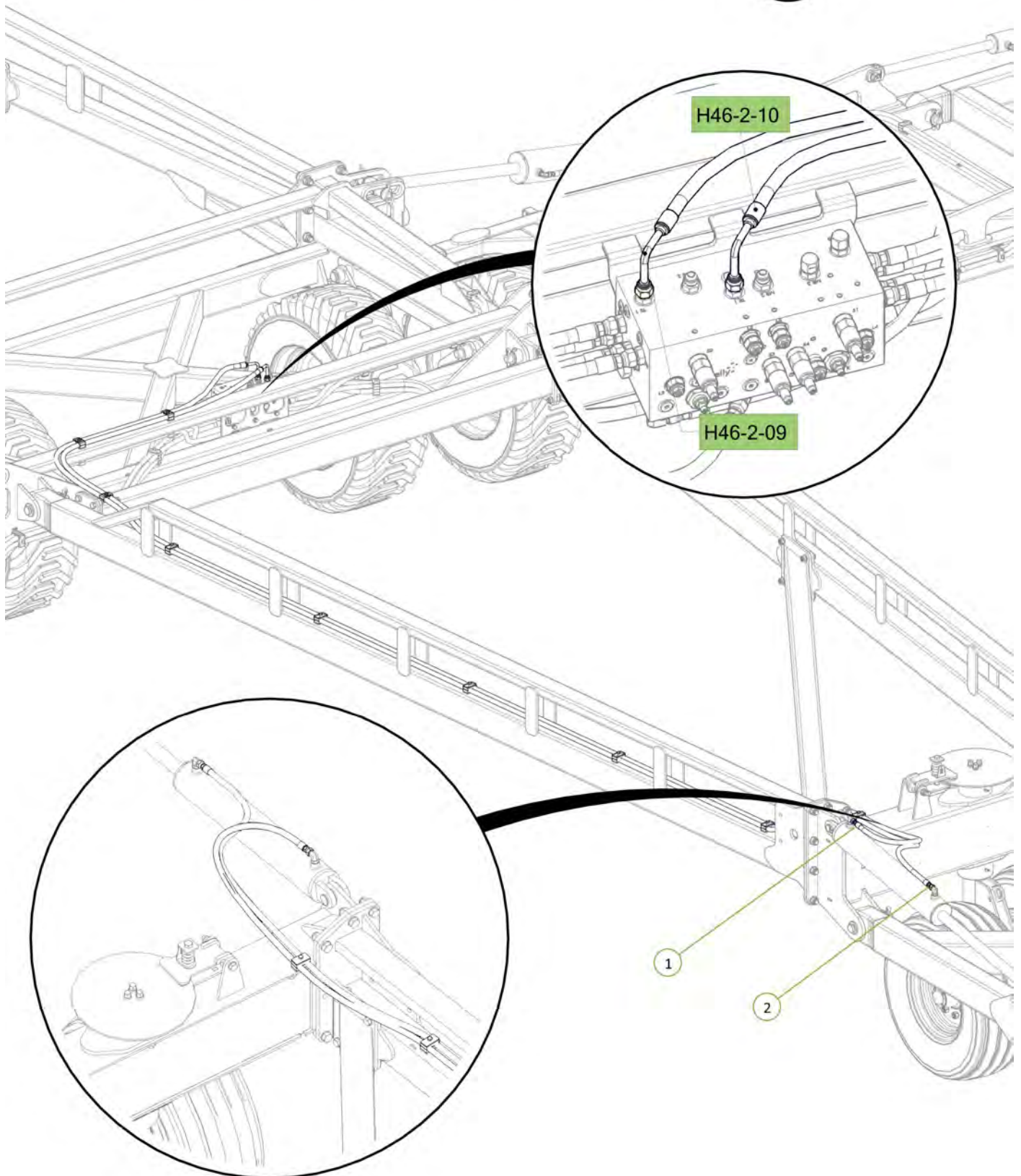
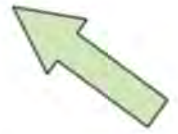

Item No.	Description	Number	Qty
1	46' Front Module Frame	1610-28-46-2	1
2	U-Bolt M16 x 190 Deep x 106 Wide	0271-16190106U	10
3	Washer Flat M16	0231-F16	20
4	Nyloc Nut M16	0221-NYL16	20

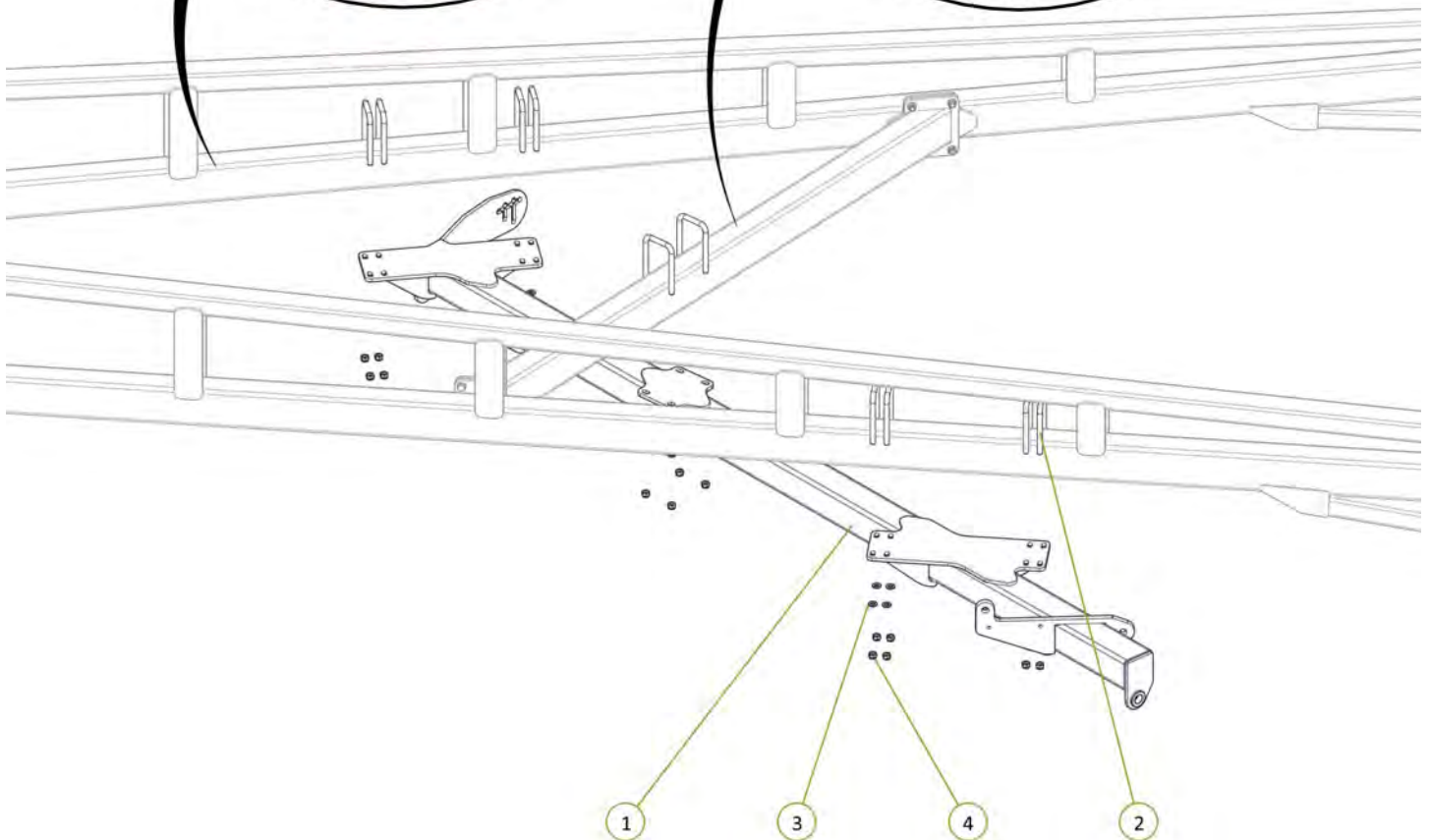
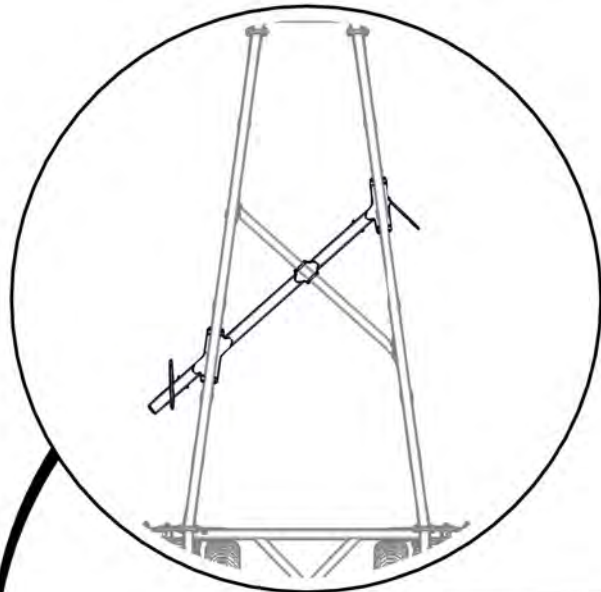
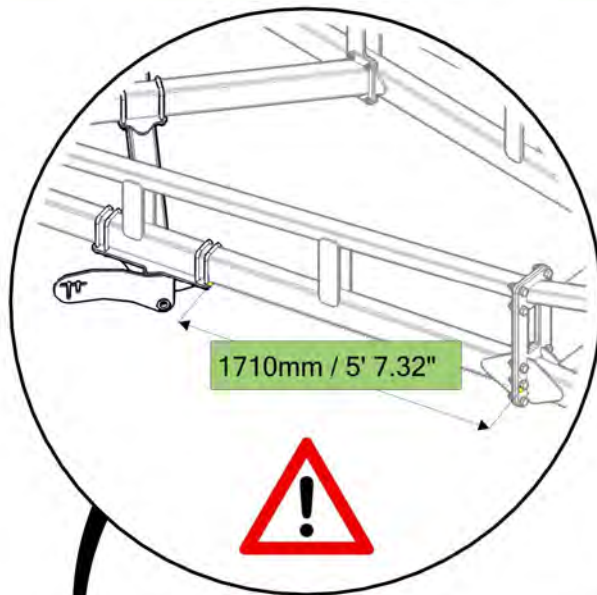
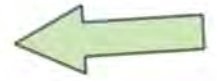

Item No.	Description	Number	Qty
1	46' Rear Module Frame	1610-29-46-2	1
2	U-Bolt M16 x 190 Deep x 106 Wide	0271-16190106U	8
3	Washer Flat M16	0231-F16	16
4	Nyloc Nut M16	0221-NYL16	16

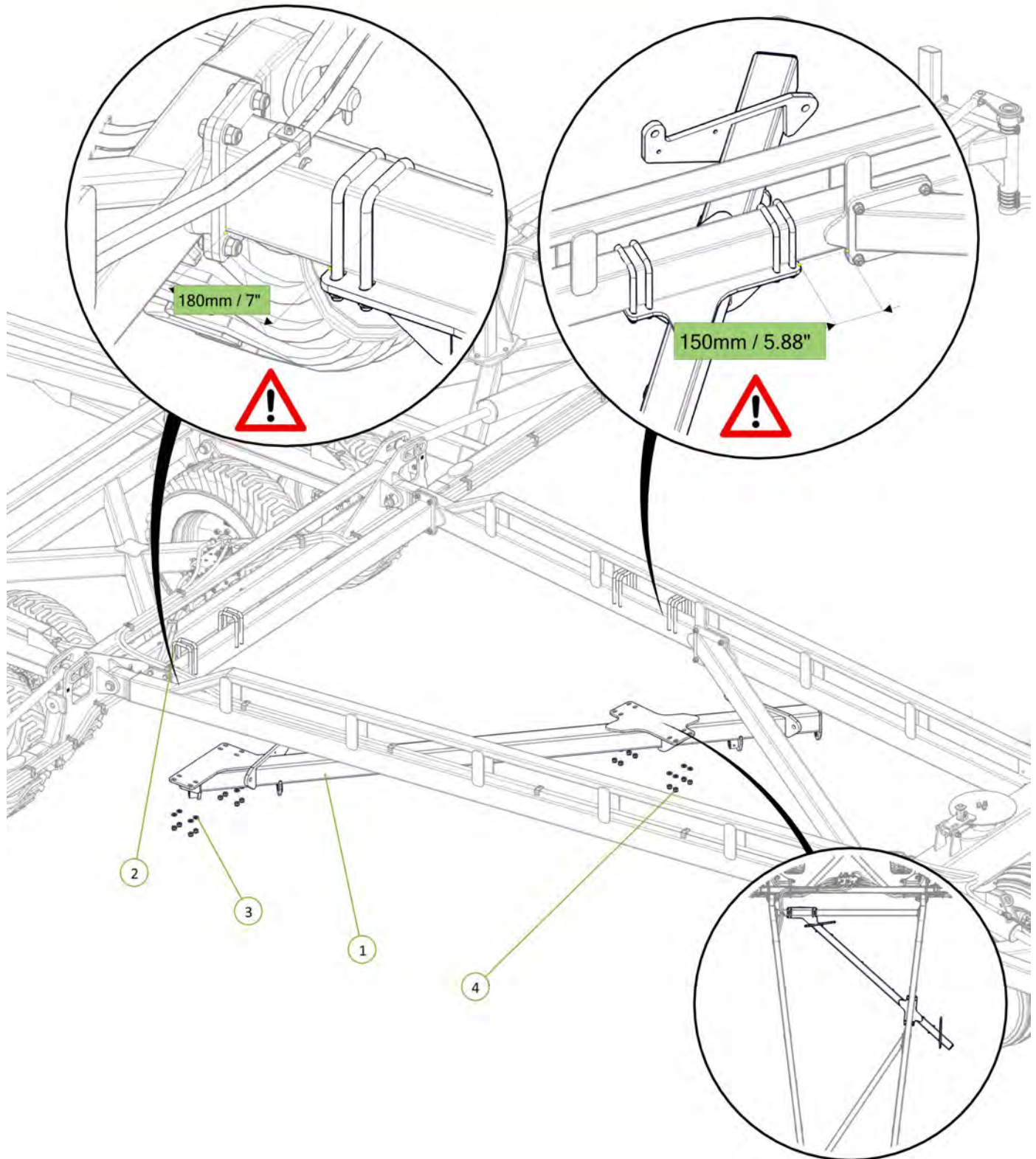

Item No.	Description	Number	Qty
1	Long Module Lift Arm	1610-106	1
2	Clevis Pin 25mm x 75mm	0801-KE0307-1	1
3	Cotter Pin M5 x 50	0261-PINC550	1
4	Washer Flat M24	0231-F24	1

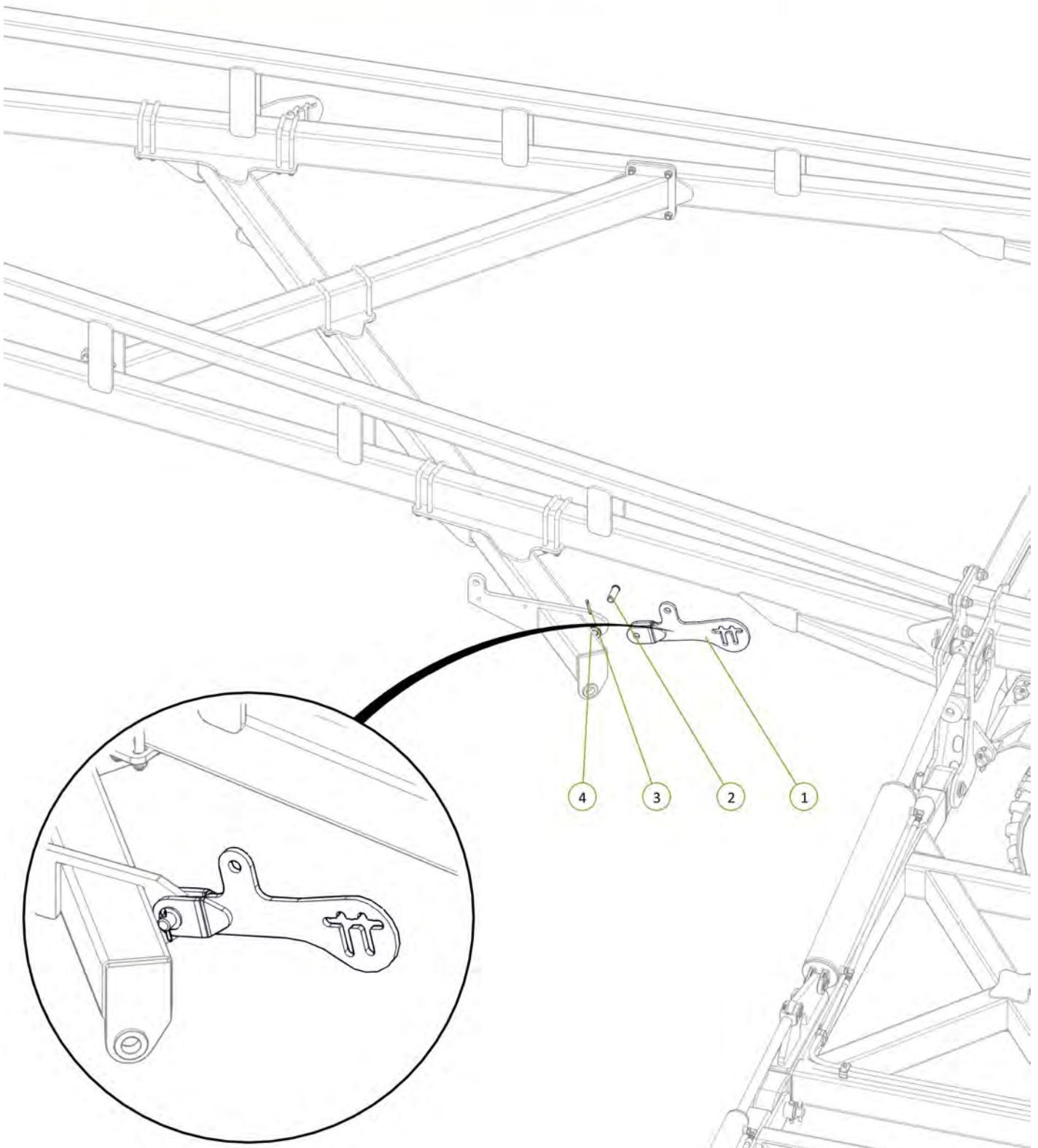

Item No.	Description	Number	Qty
1	2.5" Bore x 6" Stroke 1.5" Rod Side Port Cylinder	0311-256SP	1

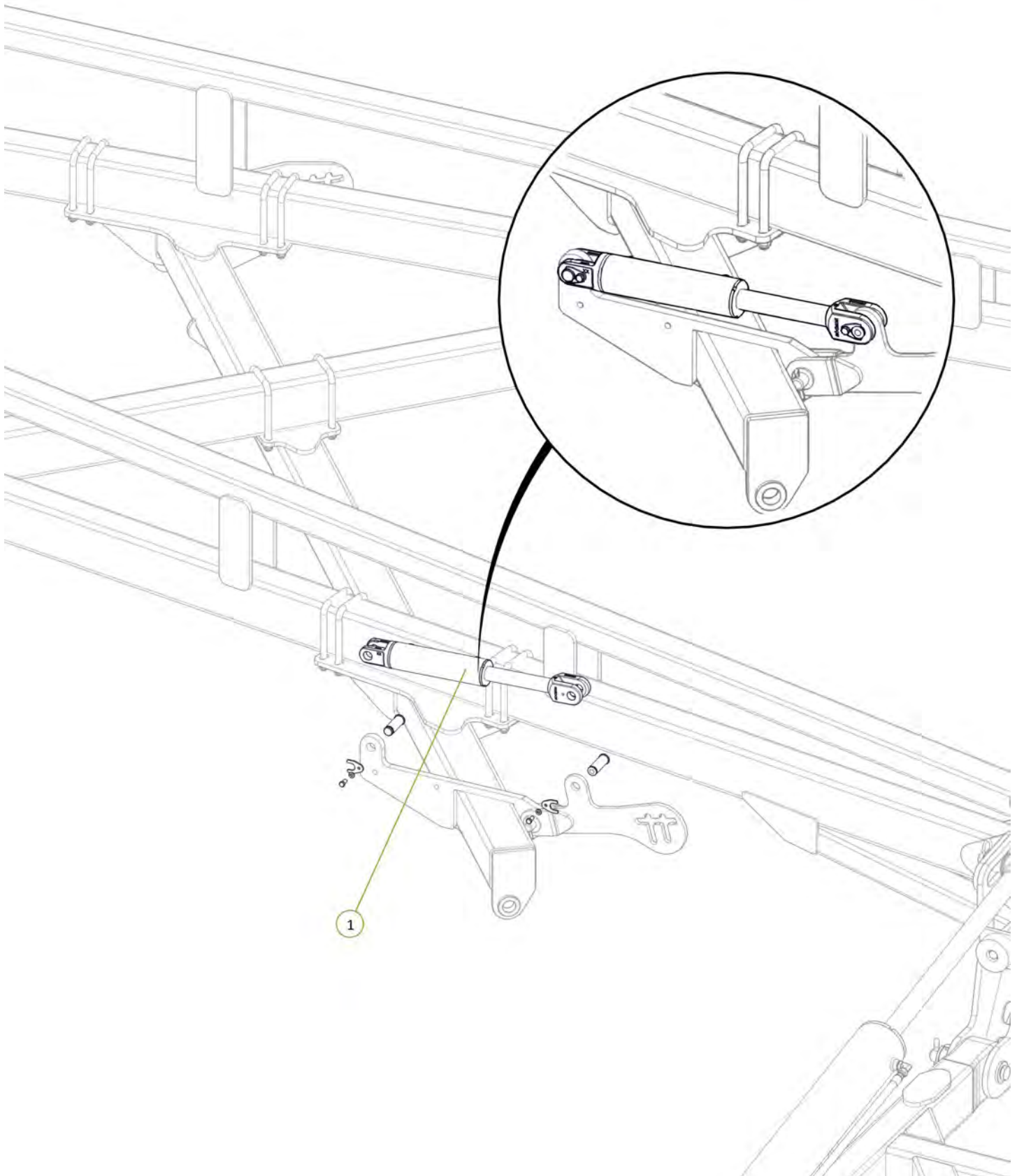

Item No.	Description	Number	Qty
1	3/4" JIC Male 3/4" UN O Ring Male 90° Elbow	0323-S91-1212	1
2	3/4" JIC Male 3/4" UN O Ring Male 45° Elbow	0323-S88-1212	1

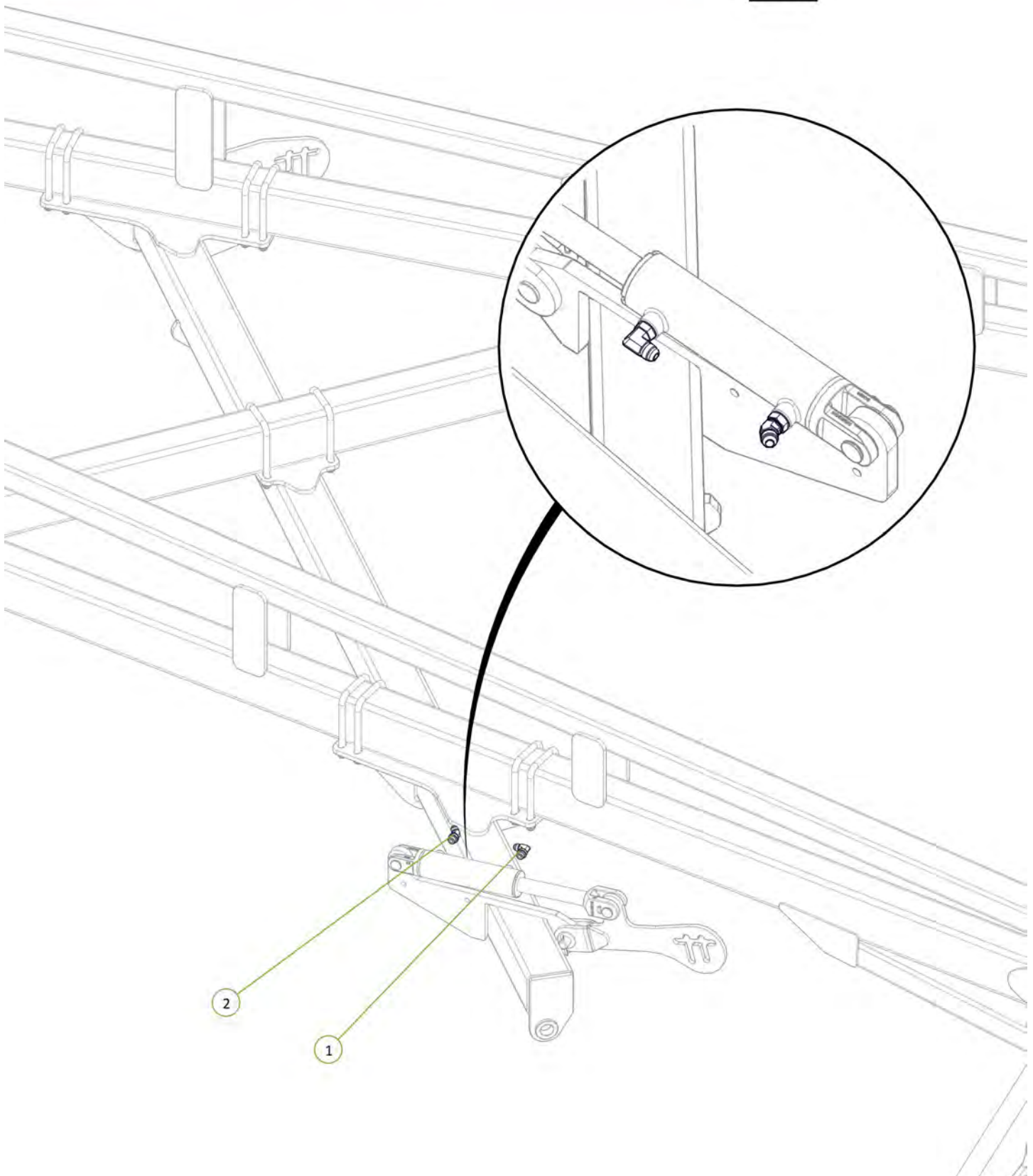
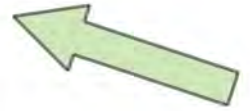

Item No.	Description	Number	Qty
1	Sequence Valve ME3 Port to Front Module Cylinder Extend Port	H46-2-07	1
2	Sequence Valve MR3 Port to Front Module Cylinder Retract Port	H46-2-08	1

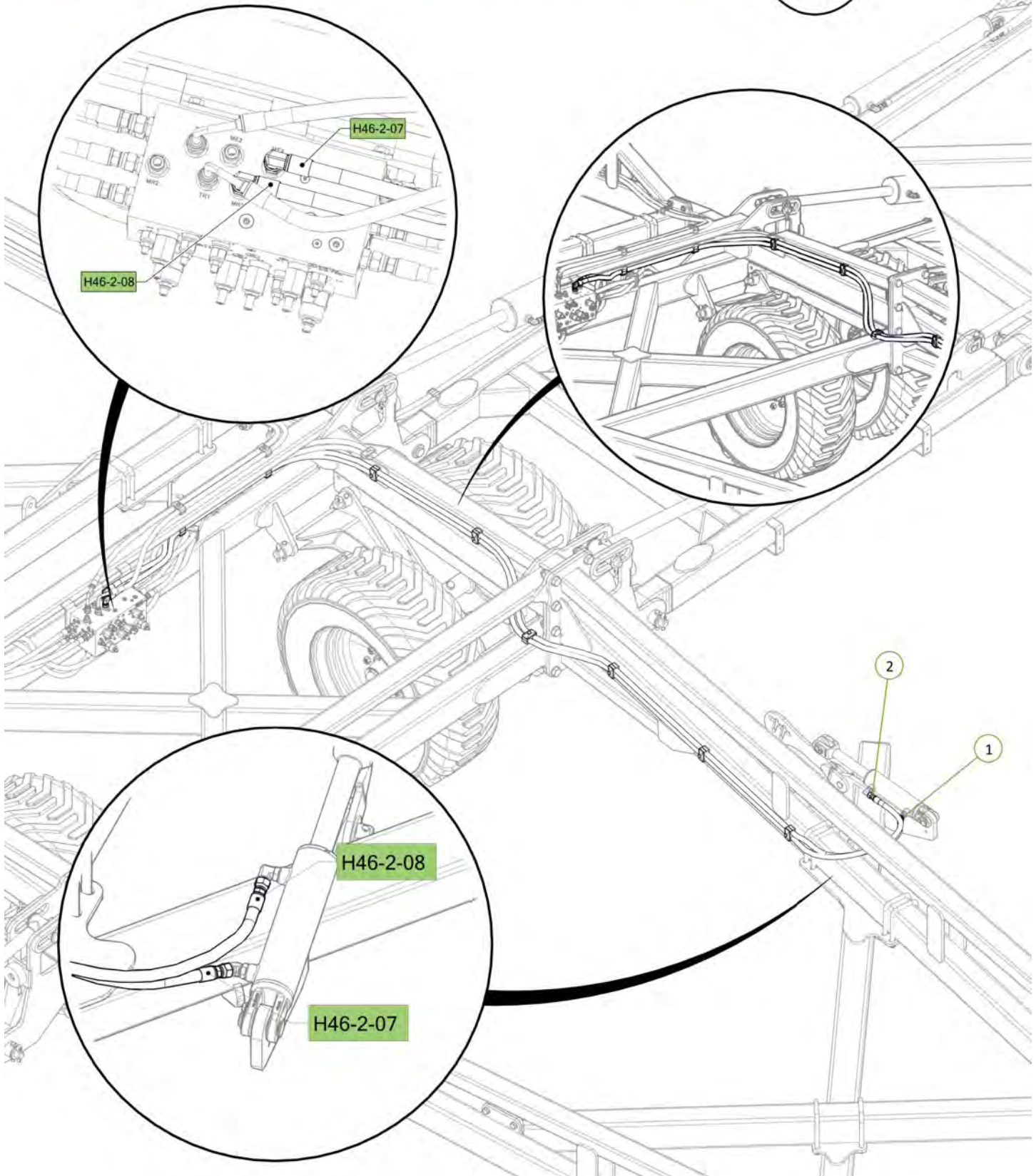

Item No.	Description	Number	Qty
1	Long Module Lift Arm	1610-106	2
2	Clevis Pin 25mm x 75mm	0801-KE0307-1	2
3	Washer Flat M24	0231-F24	2
4	Cotter Pin M5 x 50	0261-PINC550	2

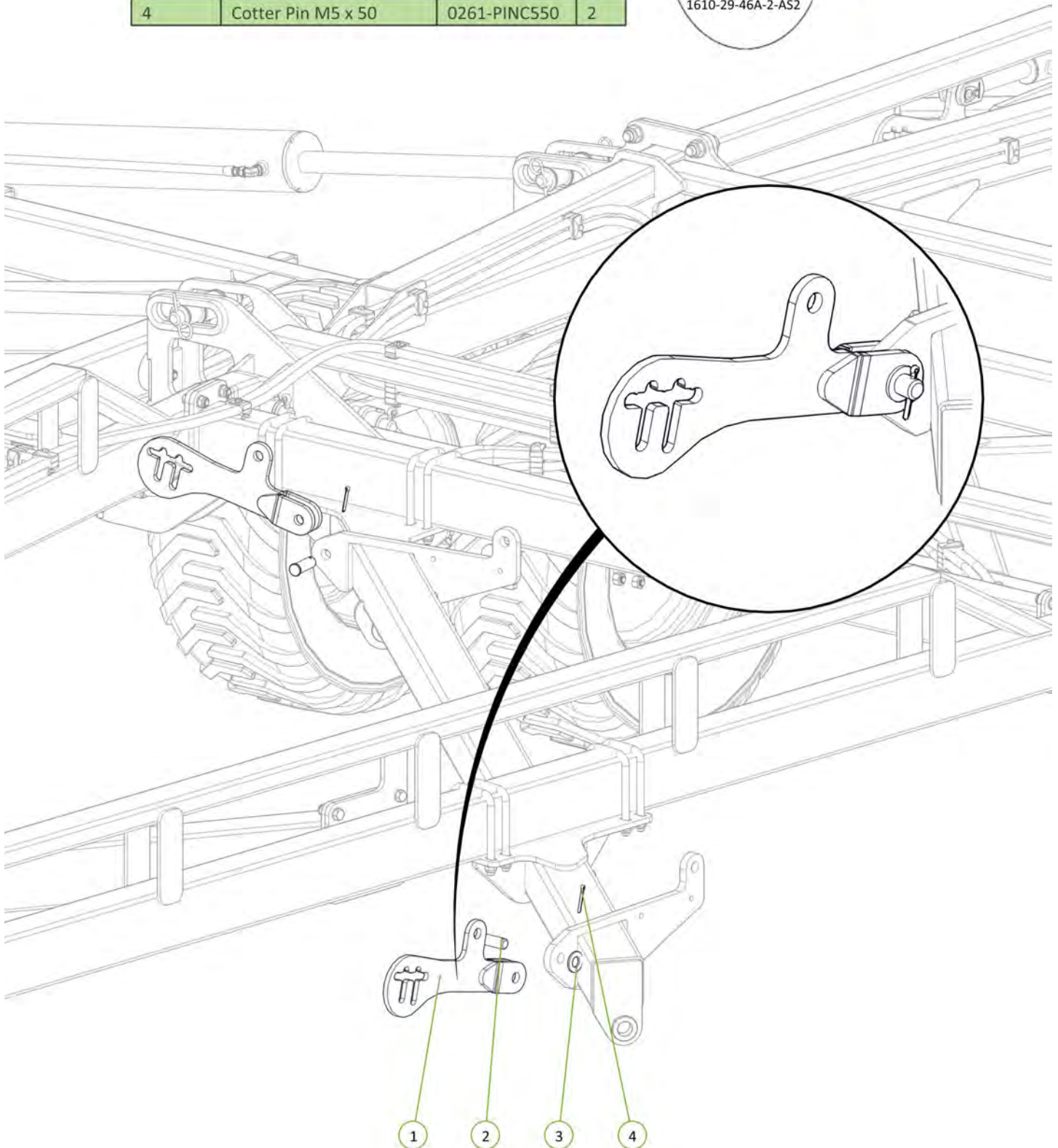

Item No.	Description	Number	Qty
1	2.5" Bore x 6" Stroke 1.5" Rod Side Port Cylinder	0311-256SP	2

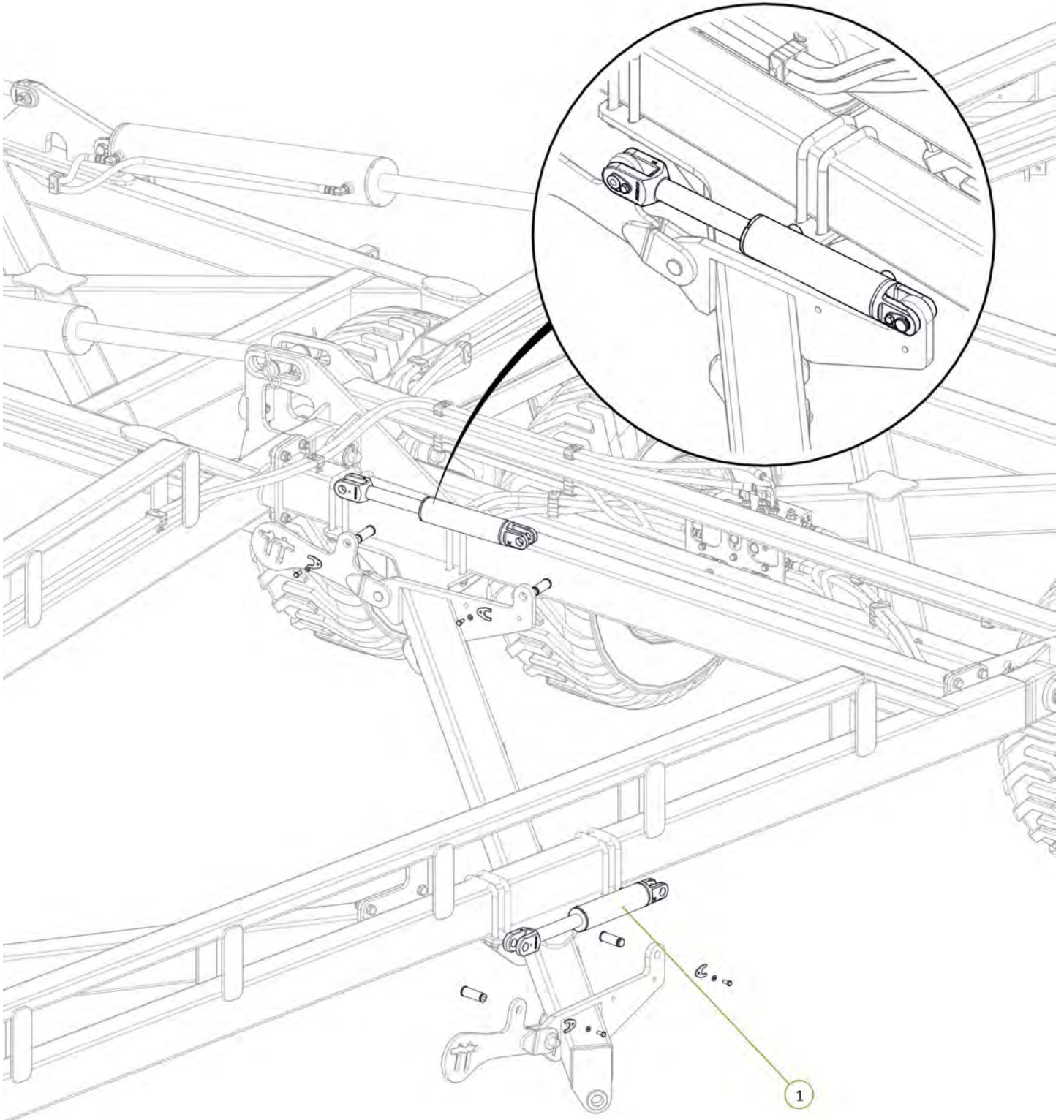

Item No.	Description	Number	Qty
1	3/4" JIC Male 3/4" UN O Ring Male 45° Elbow	0323-S88-1212	1
2	3/4" JIC Male 3/4" UN O Ring Male 90° Elbow	0323-S91-1212	1
3	3/4" JIC Male 3/4" JIC Male 3/4" UN O Ring Male Tee	0324-S92-121212	2

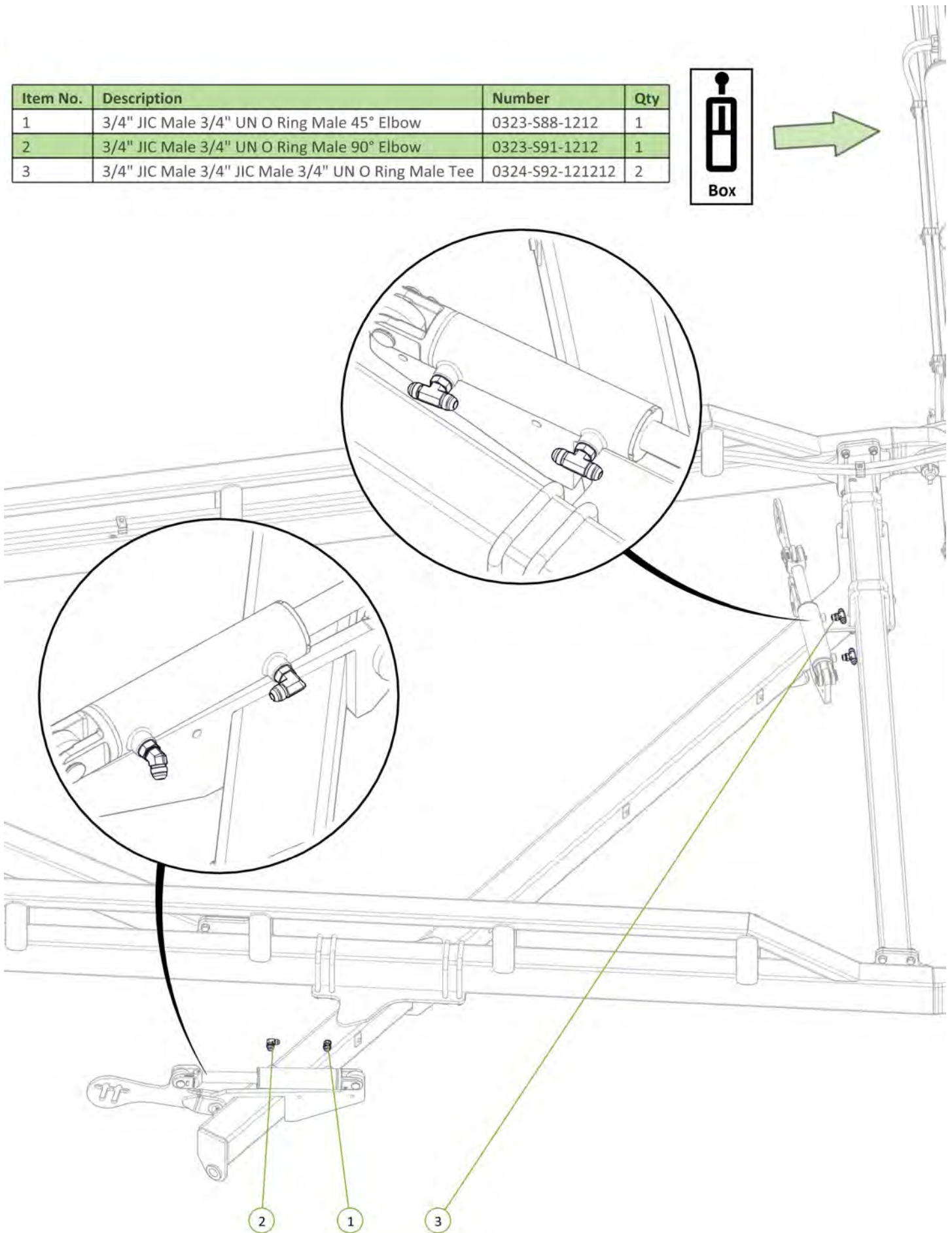
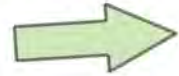

Item No.	Description	Number	Qty
1	Sequence Valve ME2 Port to LH Rear Module Extend Tee	H46-2-11	1
2	Sequence Valve MR2 Port to LH Rear Module Retract Tee	H46-2-13	1

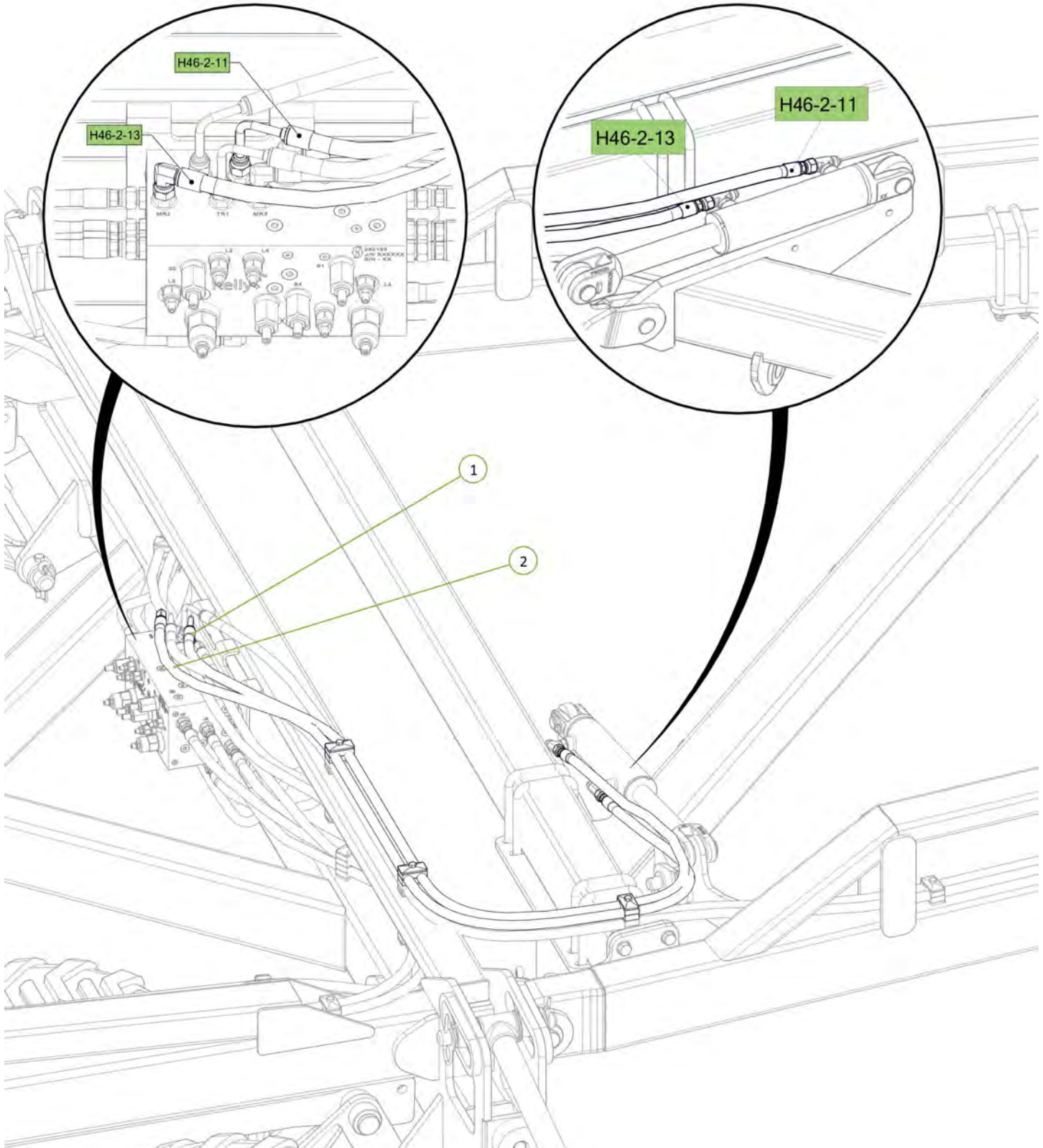
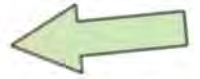

Item No.	Description	Number	Qty
1	LH Rear Module Extend Tee to RH Rear Module Cylinder Extend Port	H46-2-12	1
2	LH Rear Module Retract Tee to RH Rear Module Cylinder Retract Port	H46-2-14	1

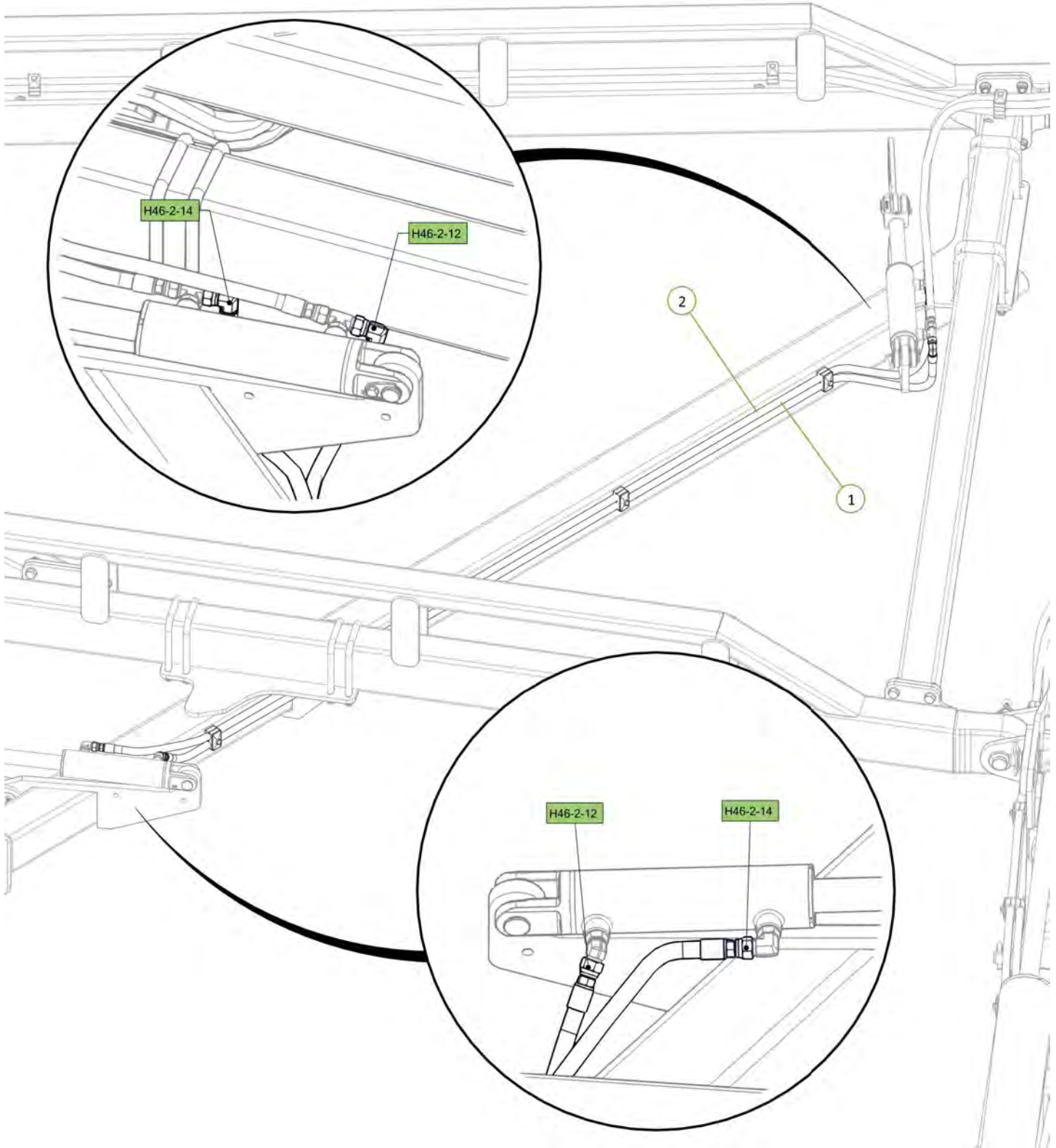

Item No.	Description	Number	Qty
1	46' Chain Carrier Beam	0810-17-45-46	1
2	Chain Carrier Mount Plate	0800-139.1	2
3	U-Bolt M16 x 162 Deep x 129 Wide	0271-16162129U	4
4	U-Bolt M16 x 114 Deep x 106 Wide	0271-16114106U	4
5	Washer Flat M16	0231-F16	16
6	Nyloc Nut M16	0221-NYL16	16

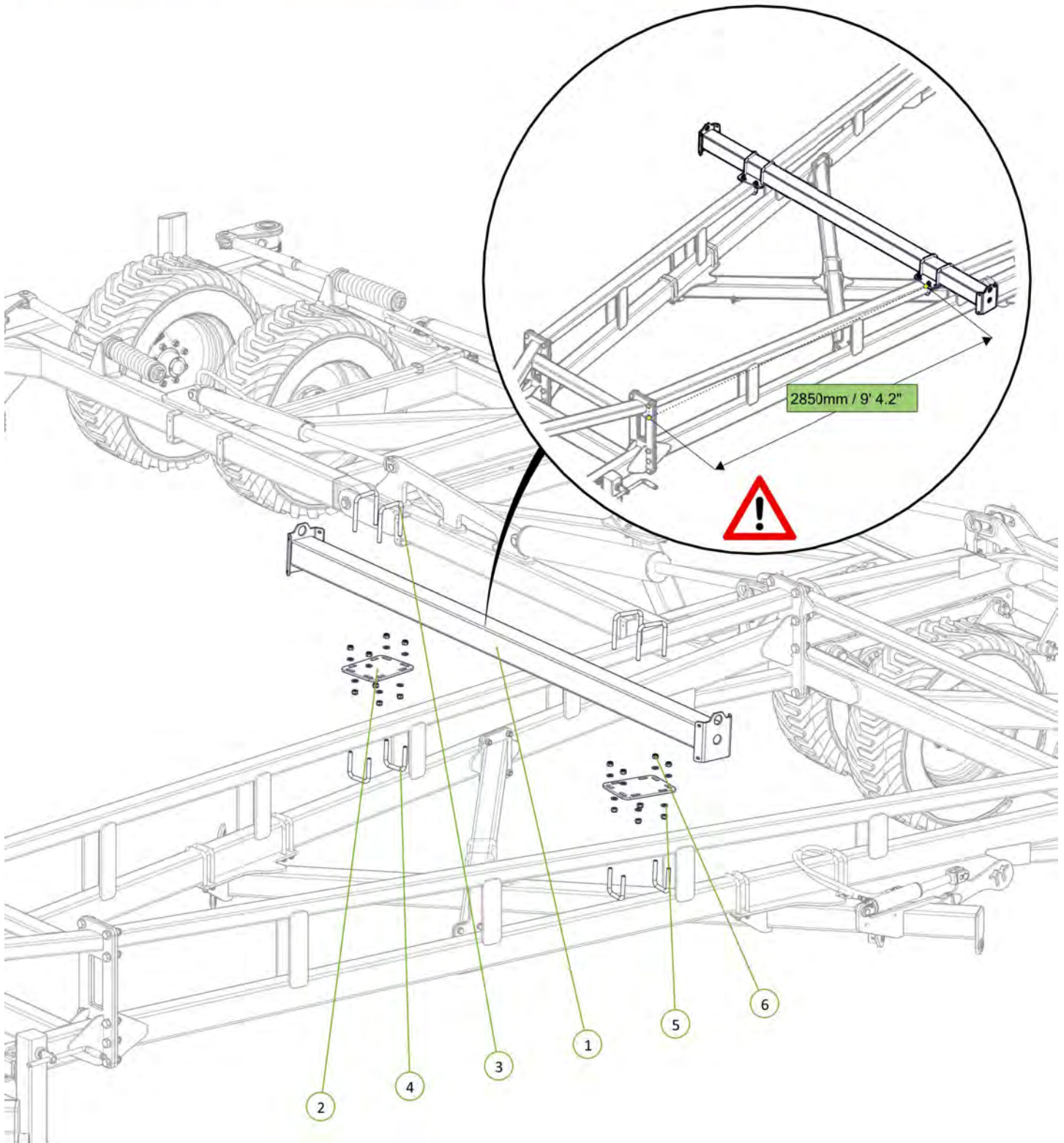

Item No.	Description	Number	Qty
1	Extended Chain Carrier Bolt on End	0810-17LE	2
2	M12 x 30 Coach Head Bolt	0215-CH1230	8
3	Washer Flat M12	0231-F12	8
4	Nyloc Nut M12	0221-NYL12	8

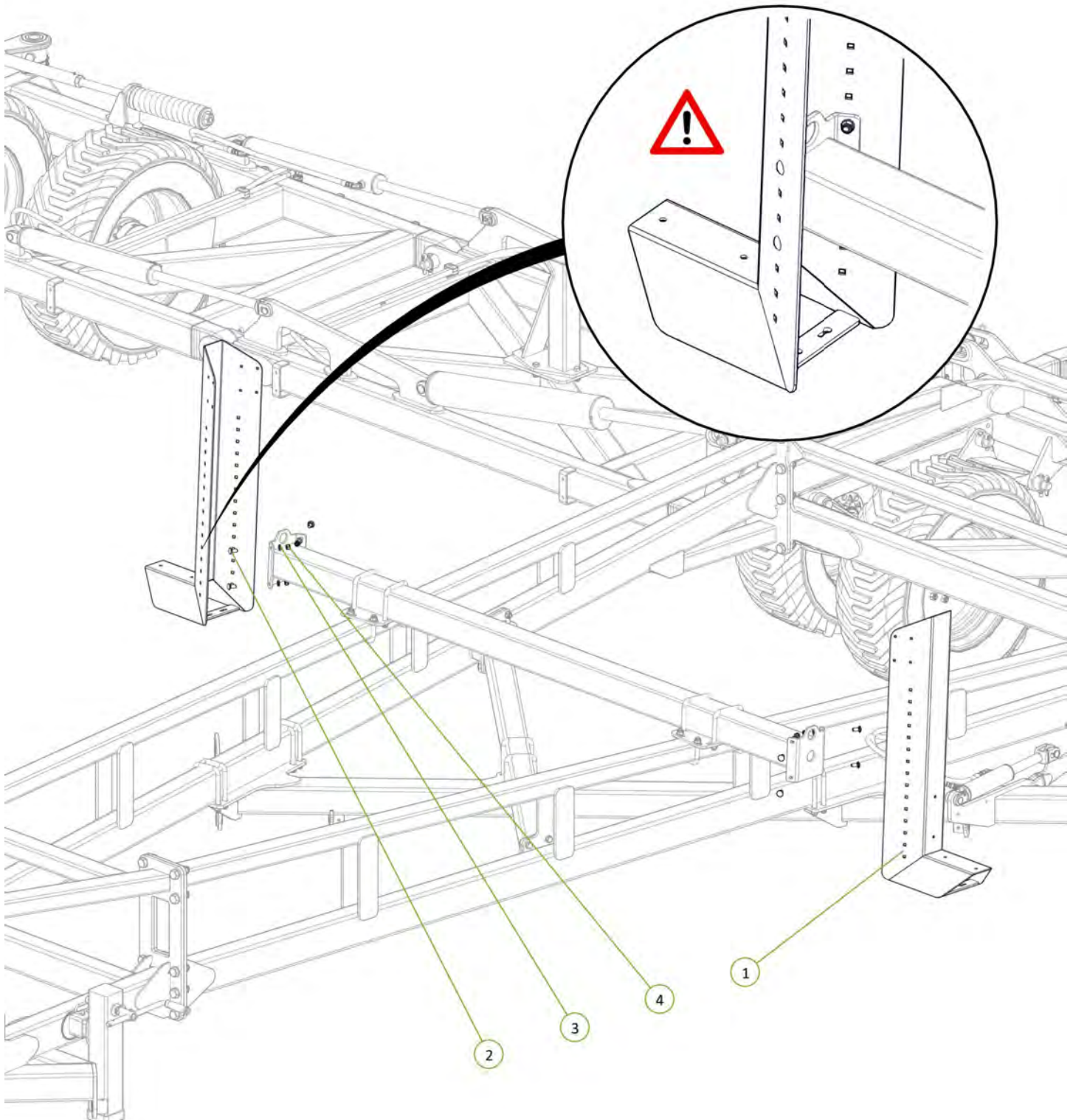

Item No.	Description	Number	Qty
1	46' Chain Carrier Beam	0810-17-45-46	1
2	300mm Chain Carrier Pedestal	1510-43	2
3	U-Bolt M16 x 104 Wide x 85 Deep	0271-1610686U	4
4	U-Bolt M16 x 162 Deep x 129 Wide	0271-16162129U	4
5	Washer Flat M16	0231-F16	16
6	Nyloc Nut M16	0221-NYL16	16

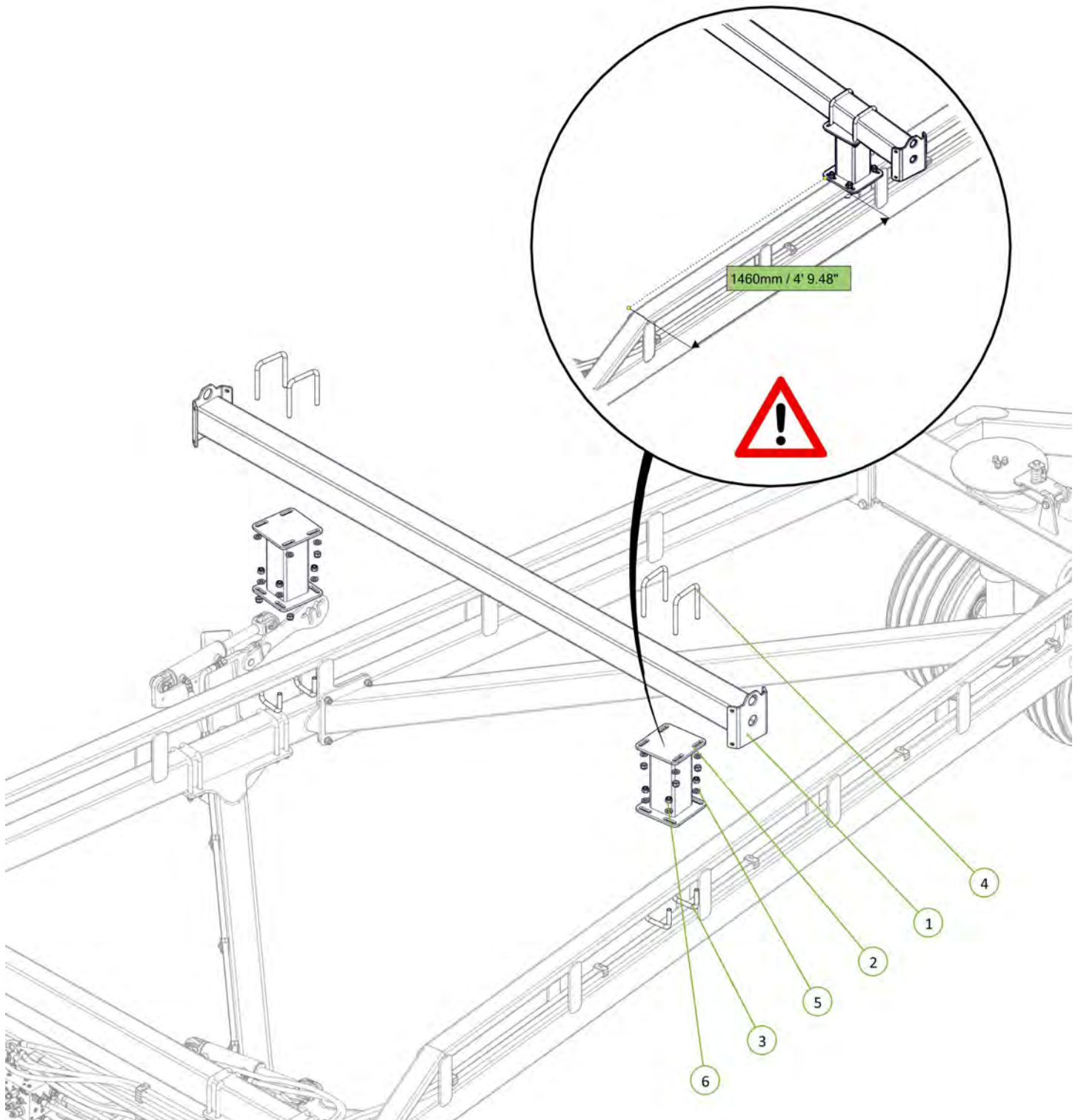
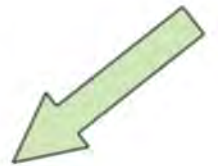

Item No.	Description	Number	Qty
1	Extended Chain Carrier Bolt on End	0810-17LE	2
2	M12 x 30 Coach Head Bolt	0215-CH1230	8
3	Washer Flat M12	0231-F12	8
4	Nyloc Nut M12	0221-NYL12	8

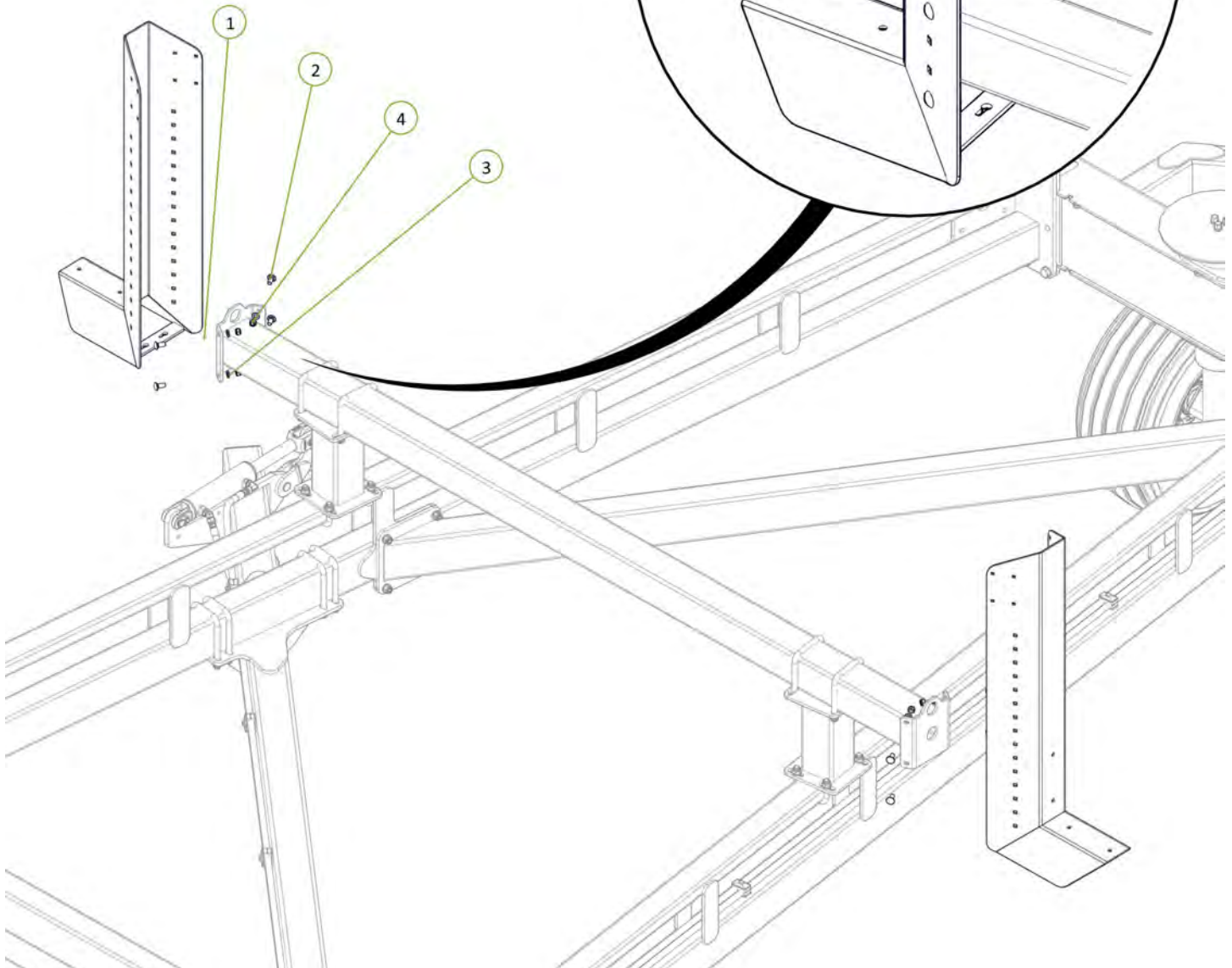
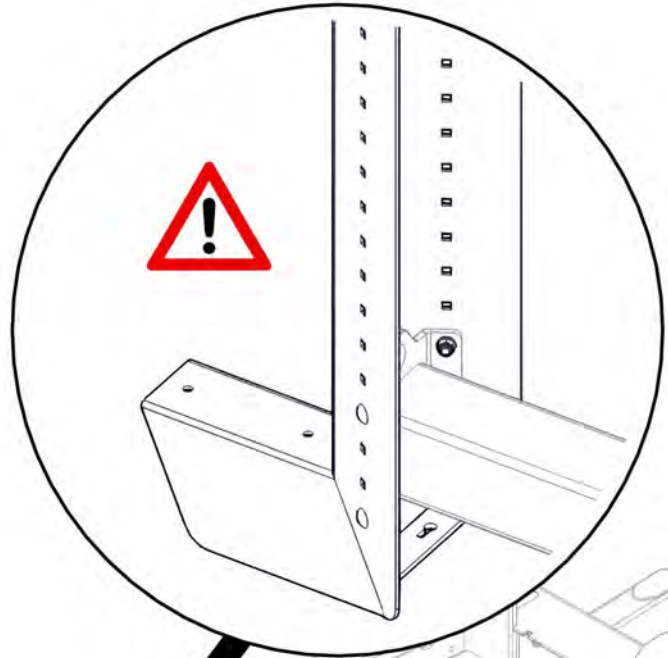

Item No.	Description	Number	Qty
1	46' Outrigger	1610-109	2
2	M16 x 50 grade 8.8 zp Bolt	0211-1650	8
3	Nyloc Nut M16	0221-NYL16	8
4	Washer Flat M16	0231-F16	16

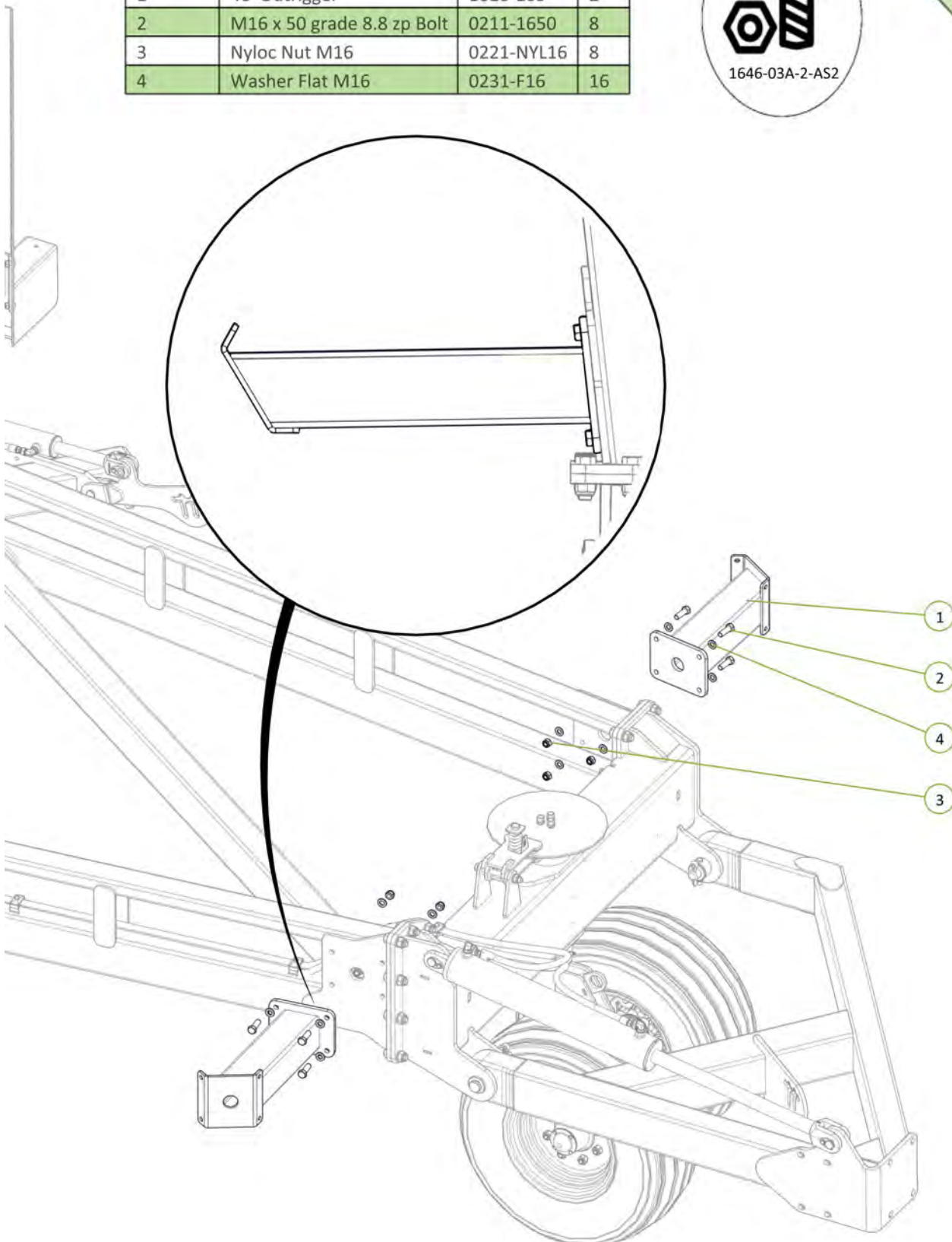
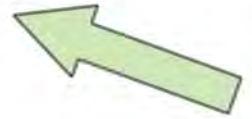

Item No.	Description	Number	Qty
1	Extended Chain Carrier Bolt on End	0810-17LE	2
2	M12 x 30 Coach Head Bolt	0215-CH1230	8
3	Washer Flat M12	0231-F12	8
4	Nyloc Nut M12	0221-NYL12	8

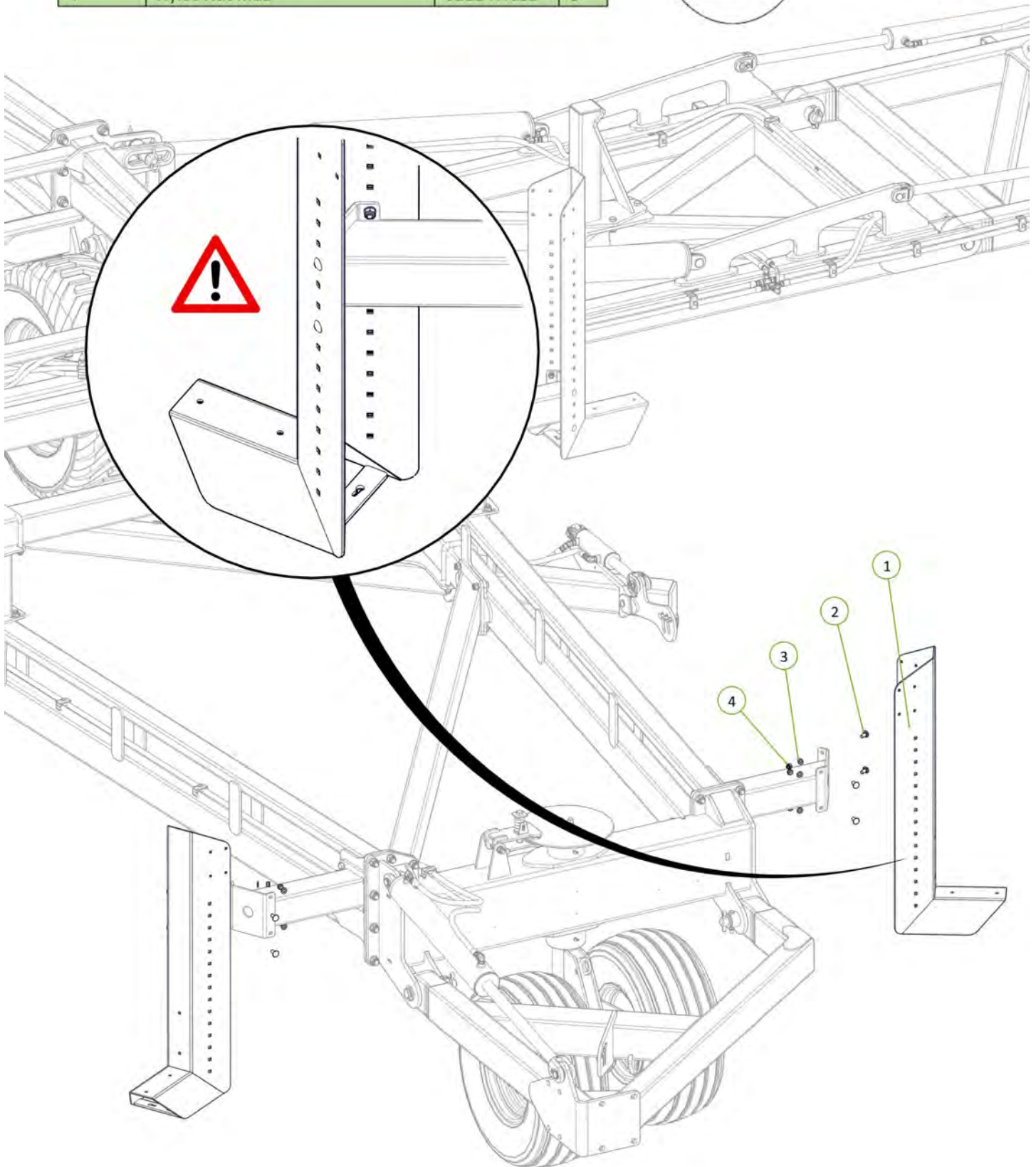

Item No.	Description	Number	Qty
1	Right Hand Off Set M	0810-18R	1
2	Left Hand Off Set M	0810-19L	1
3	Module M	1610-189	1
4	U-Bolt M12 x 106 Deep x 79 Wide	0271-1210679U	4
5	U-Bolt M12 x 157 Deep x 129 Wide	0271-12157129U	2
6	Round Tube Insert 60.3 x 3.2-5mm	0264-RTRi-5584	6
7	Washer Flat M12	0231-F12	12
8	Nyloc Nut M12	0221-NYL12	12

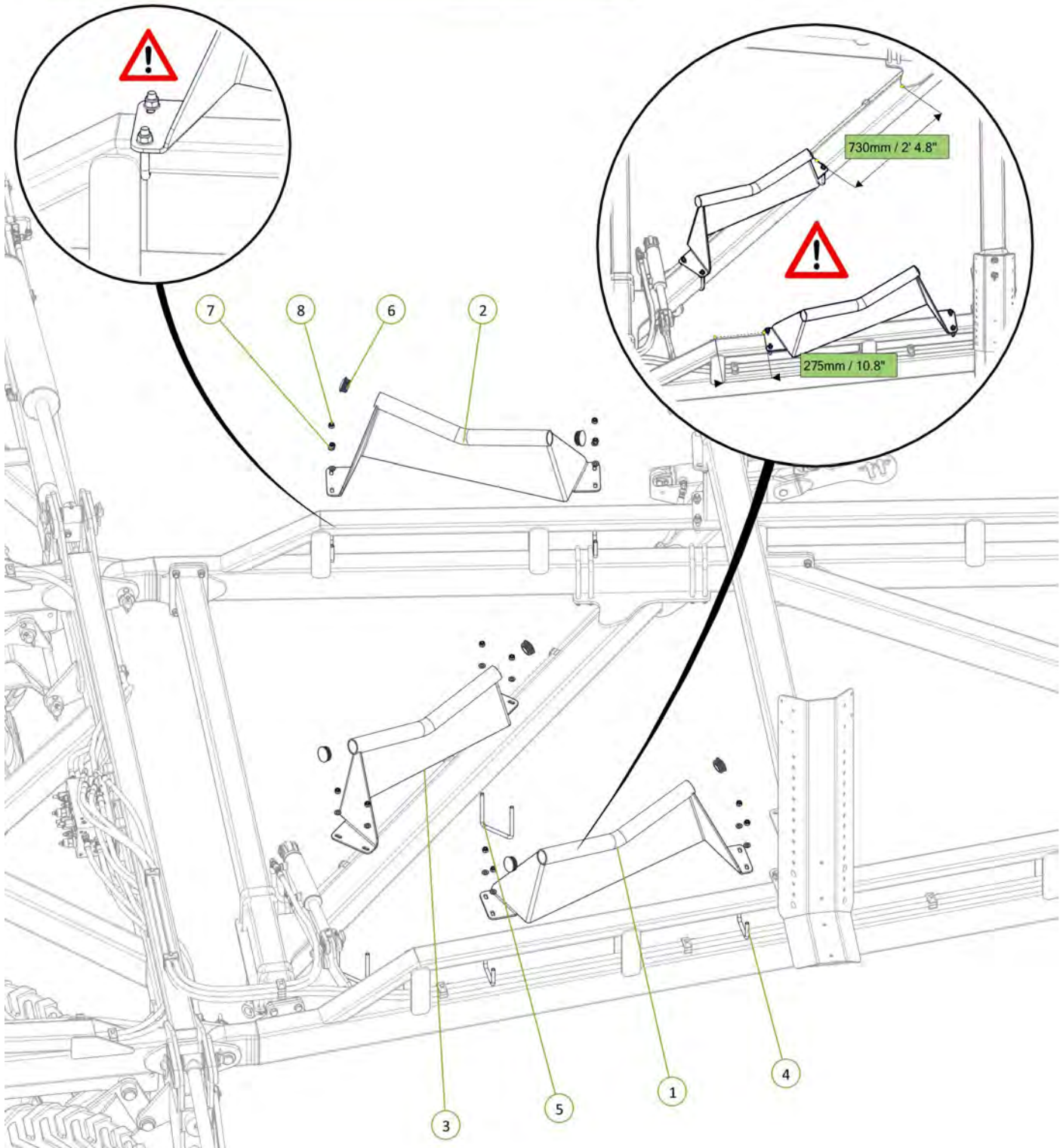

Item No.	Description	Number	Qty
1	Right Hand Off Set M	0810-18R	1
2	Left Hand Off Set M	0810-19L	1
3	Round Tube Insert 60.3 x 3.2-5mm	0264-RTRI-5584	4
4	U-Bolt M12 x 107 Deep x 106 Wide	0271-12107106U	4
5	Washer Flat M12	0231-F12	8
6	Nyloc Nut M12	0221-NYL12	8

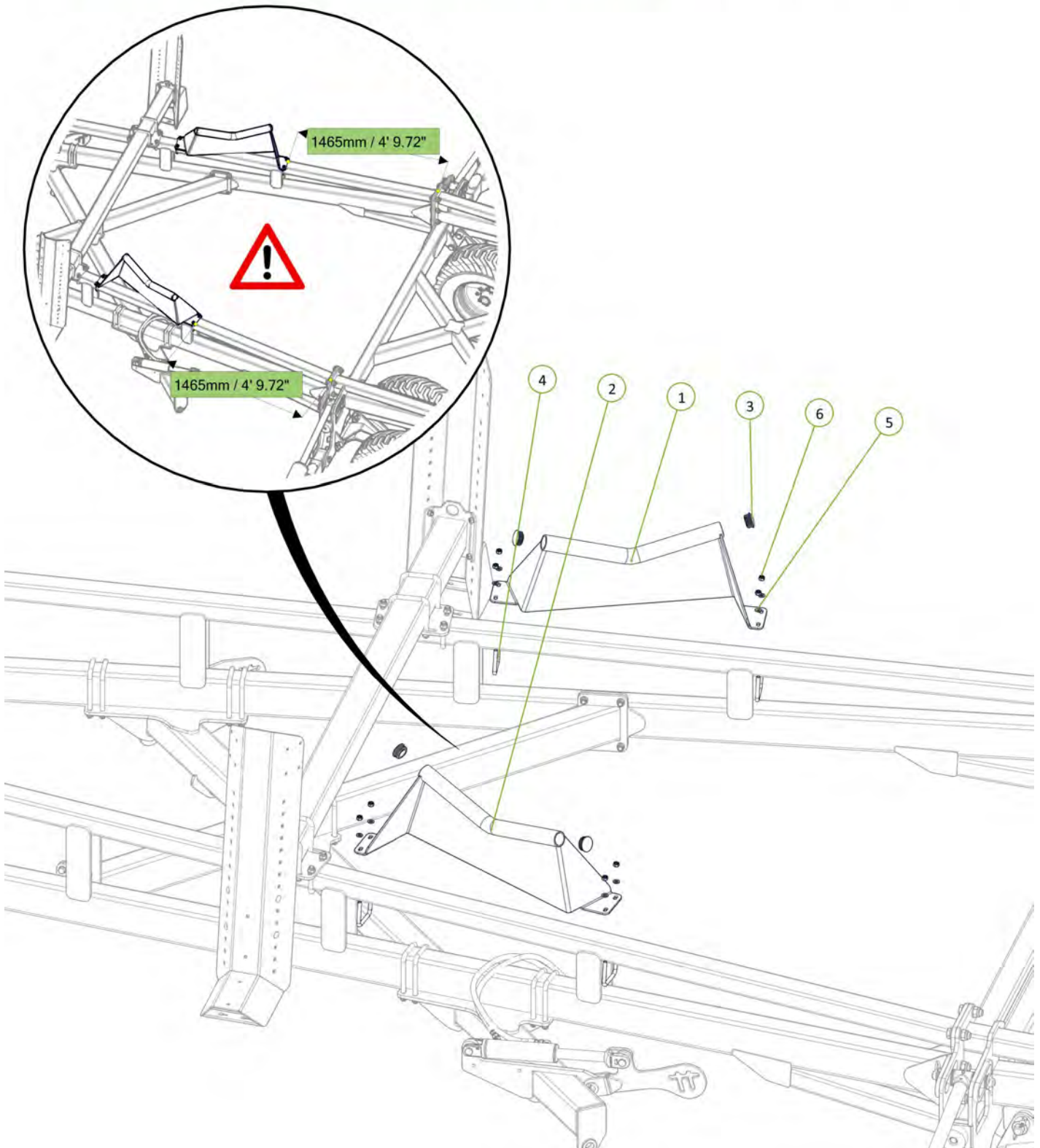

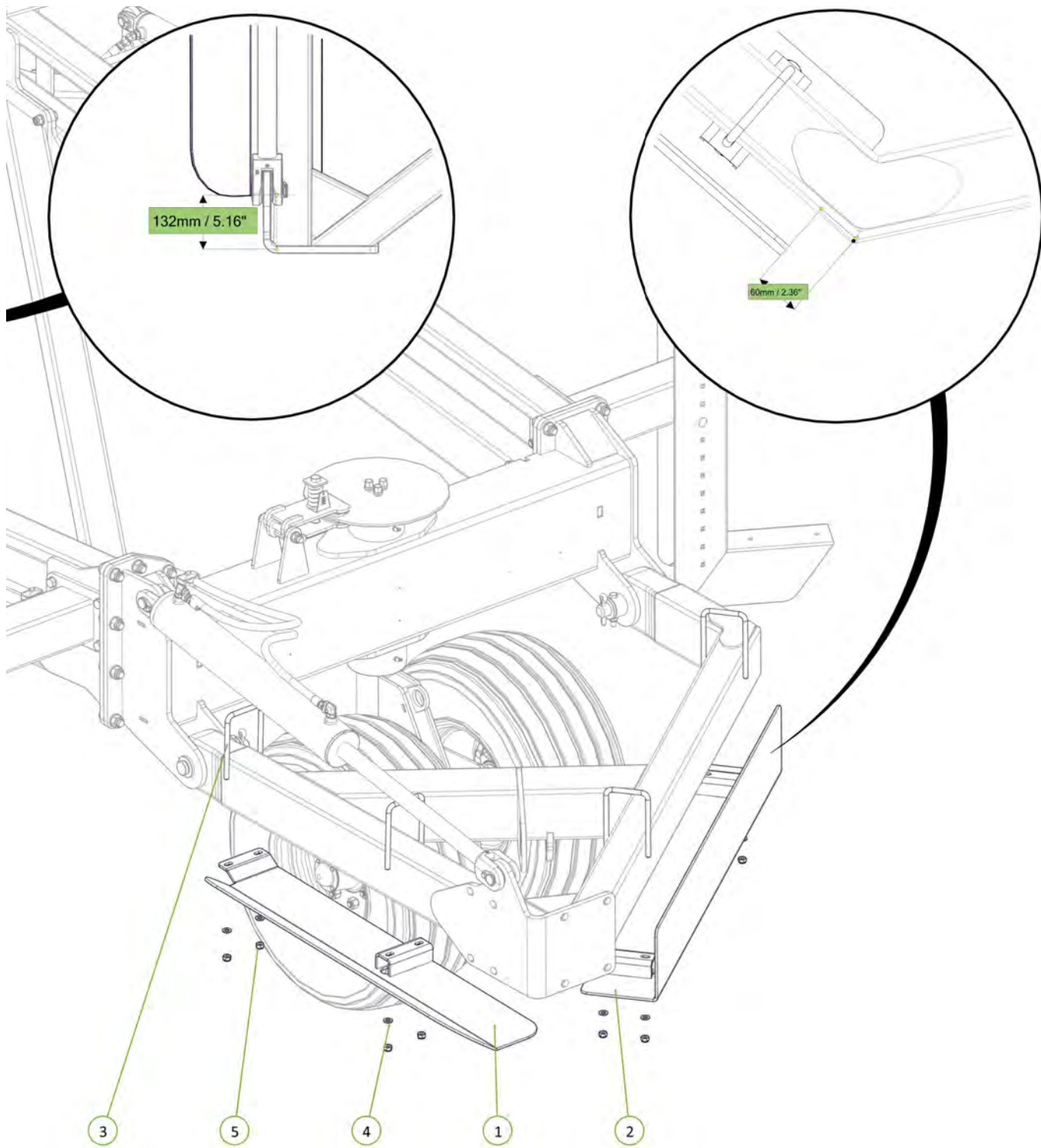

Item No.	Description	Number	Qty
1	Rear Guard 12m	1510-229	1
2	Rear Tail Guard	1610-188	1
3	U-Bolt M12 x 188 Deep x 106 Wide	0271-12188106U	4
4	Washer Flat M12	0231-F12	8
5	Nyloc Nut M12	0221-NYL12	8



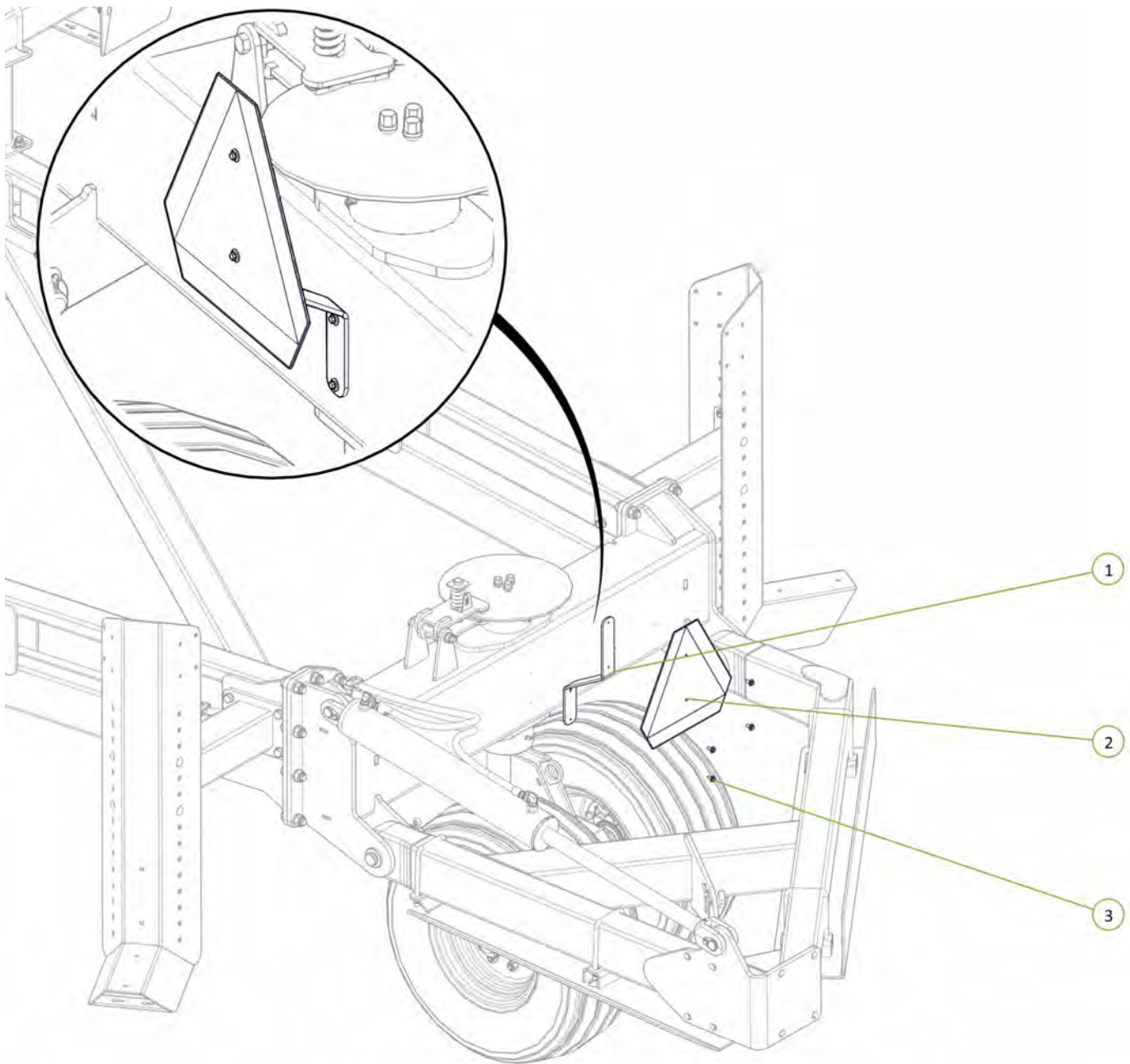

Item No.	Description	Number	Qty
1	SMV Sign Bracket	0800-195.1	1
2	Slow Moving Vehical Sign	0801-FBSMVTUF	1
3	M6 x 20 Trilobe self tapping Scew	0211-M620MZPHTF	4



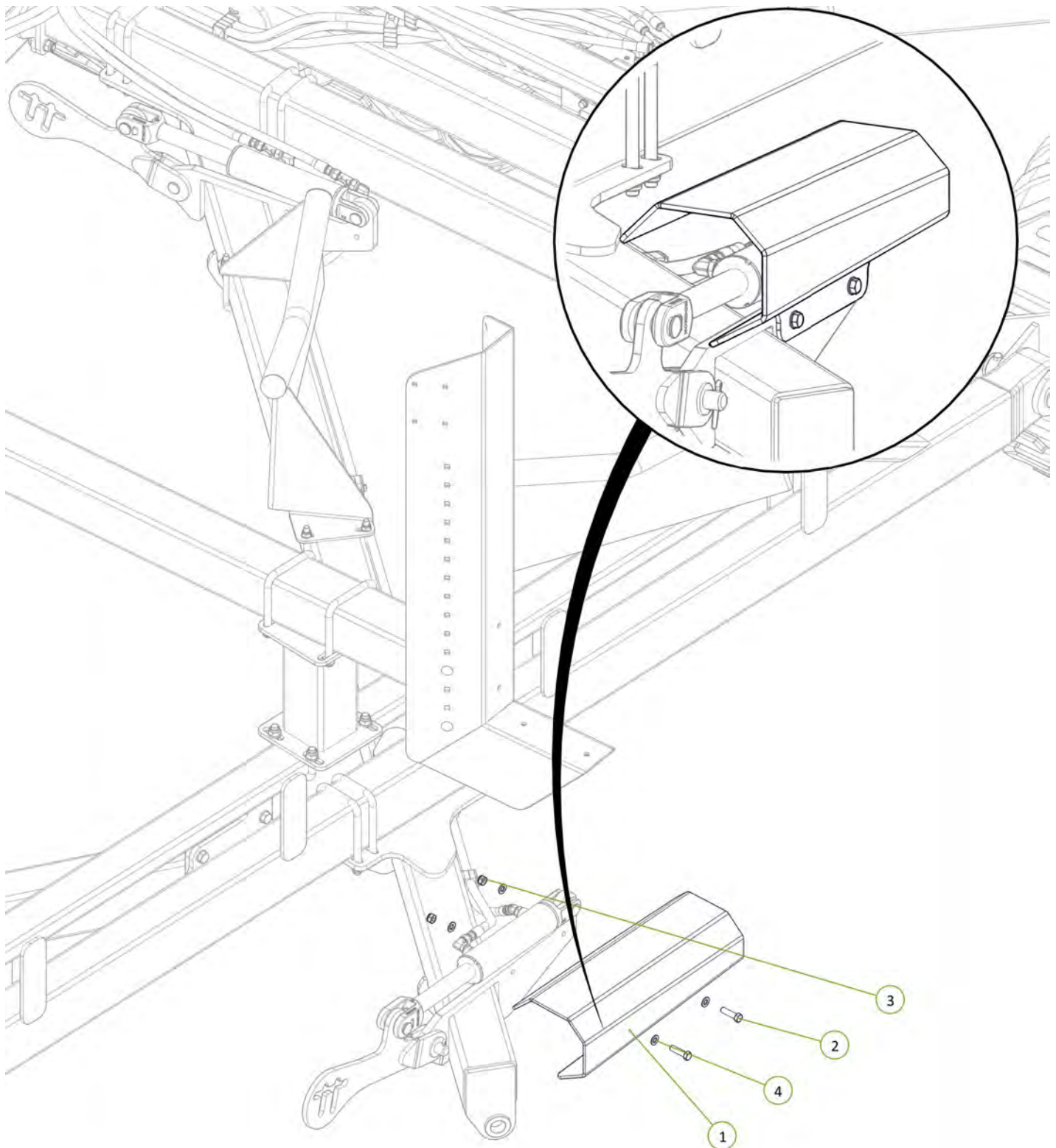

Item No.	Description	Number	Qty
1	Module Cylinder Guard	0800-167.3	1
2	M12 x 45 grade 8.8 ZP Bolt	0211-1245	2
3	Nyloc Nut M12	0221-NYL12	2
4	Washer Flat M12	0231-F12	4



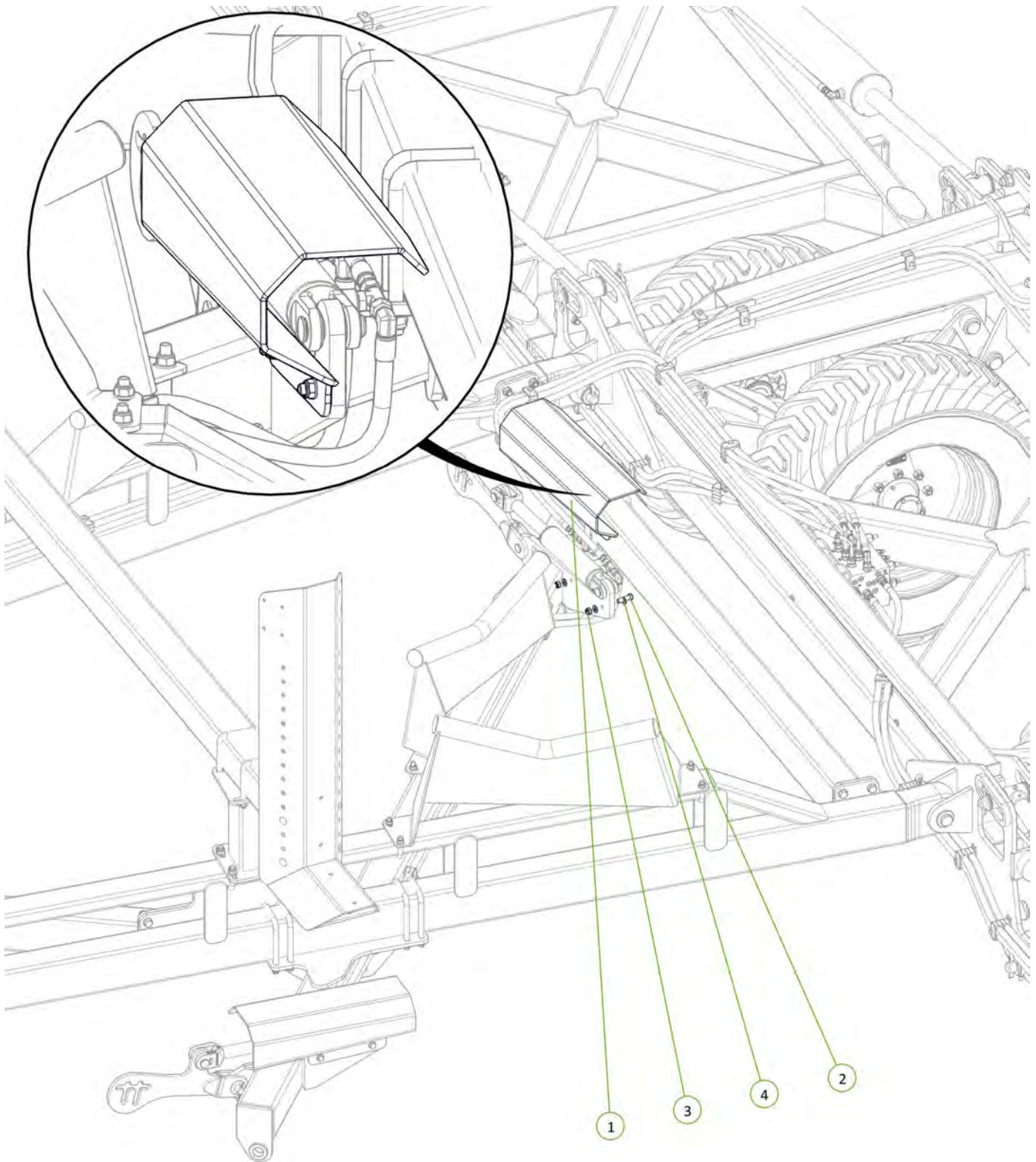

Item No.	Description	Number	Qty
1	Module Cylinder Guard	0800-167.3	1
2	M12 x 45 grade 8.8 ZP Bolt	0211-1245	2
3	Nyloc Nut M12	0221-NYL12	2
4	Washer Flat M12	0231-F12	4



Item No.	Description	Number	Qty
1	Operator Manual Cannister	0801-OMC-1	1
2	M8 x 25 grade 8.8 ZP Bolt	0211-825	3
3	Nyloc Nut M8	0221-NYL8	3
4	Washer Flat M8	0231-F8	6

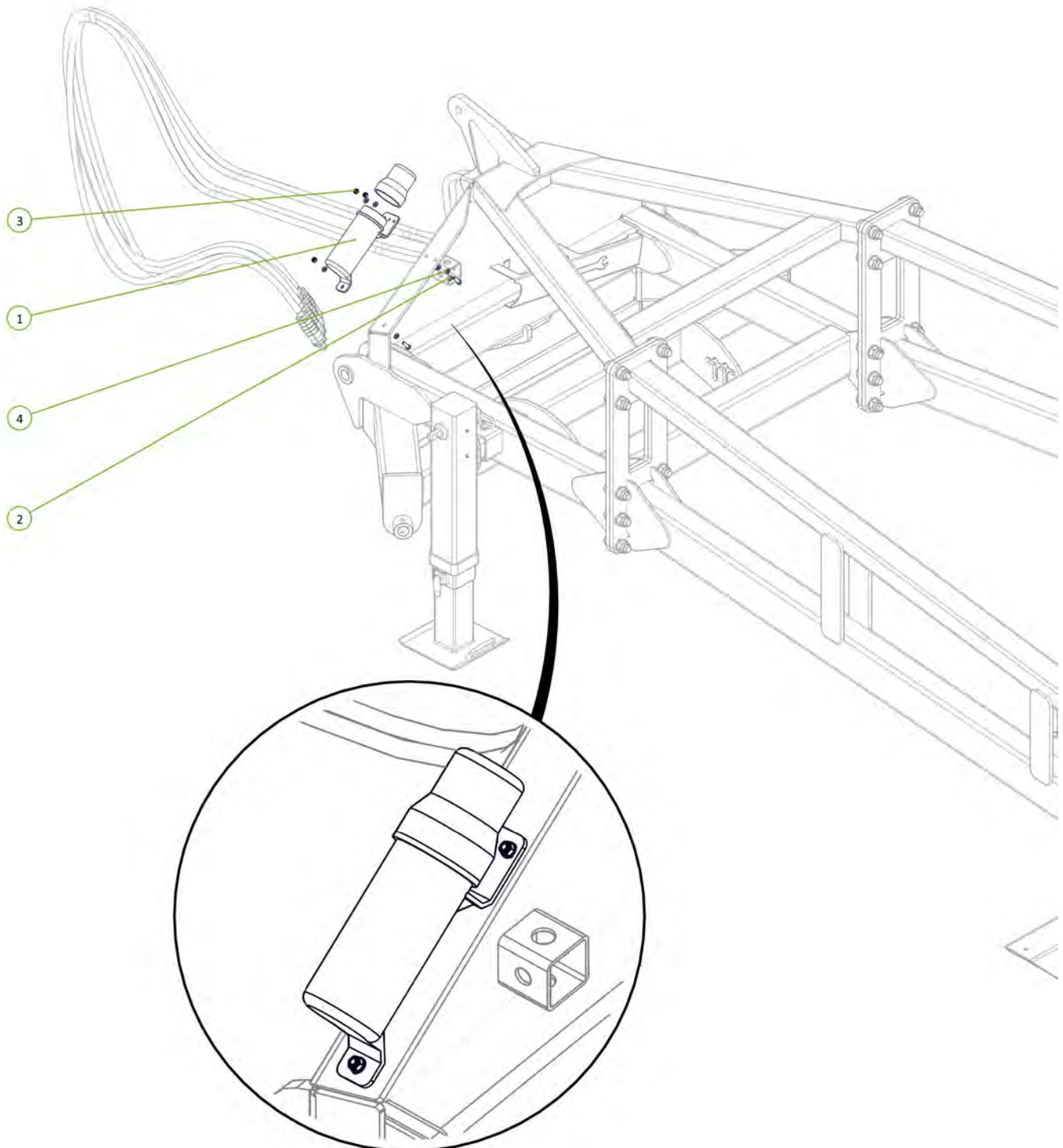

Item No.	Description	Number	Qty
1	Forged Clevis 21mm Bolt Hole	0801-FC21	2
2	Stainless Steel Wear Bush	1501-365033-SS	2
3	M36 x 105 grade 8.8 zp Bolt	0211-36105	2
4	Nyloc Nut M36	0221-NYL36	2

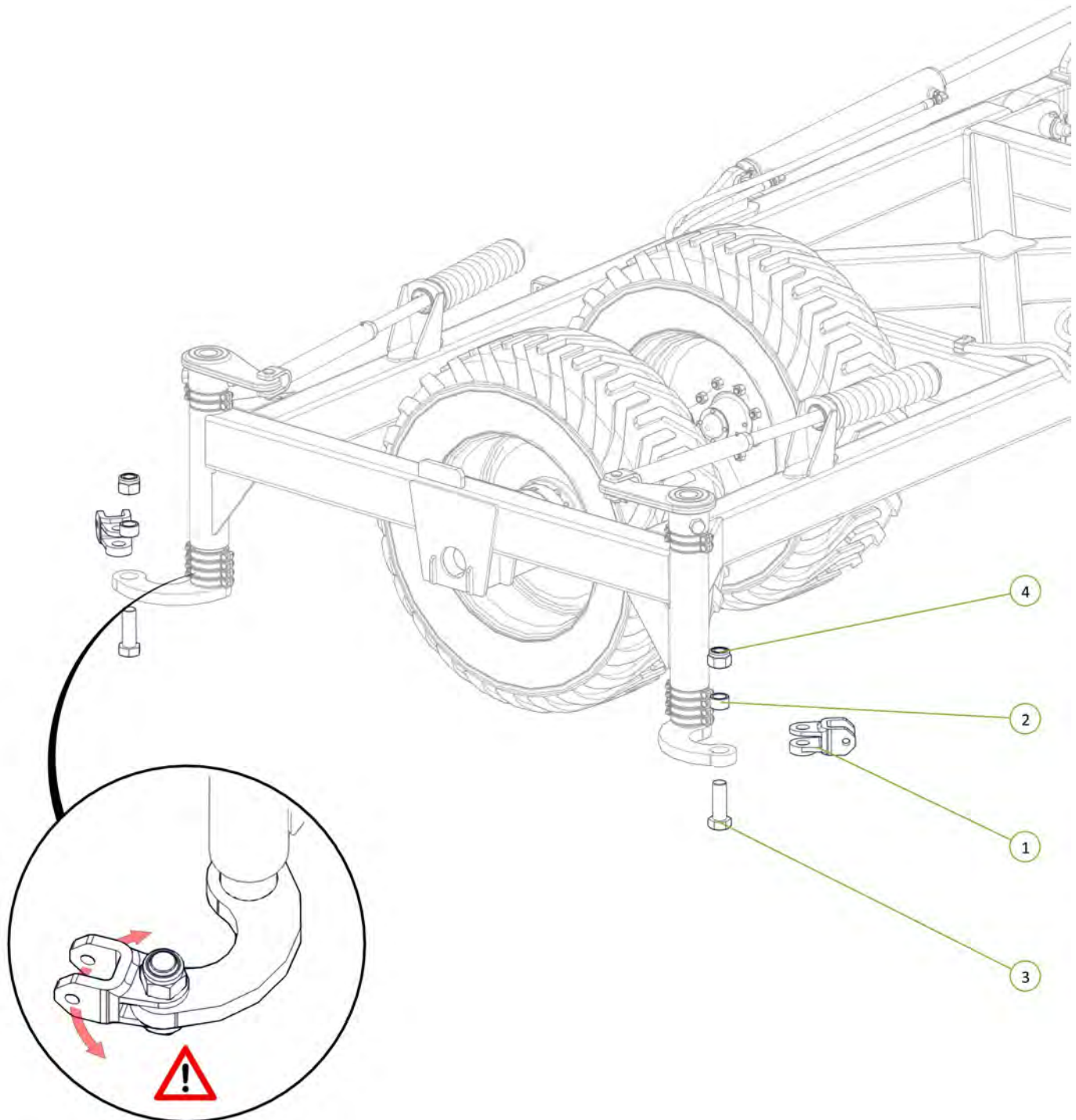

Ensure the clevis can pivot after installation

Item No.	Description	Number	Qty
1	Forged Clevis 21mm Bolt Hole	0801-FC21	2
2	Stainless Steel Wear Bush	1501-365033-SS	2
3	Nyloc Nut M36	0221-NYL36	2
4	M36 x 105 grade 8.8 zp Bolt	0211-36105	2

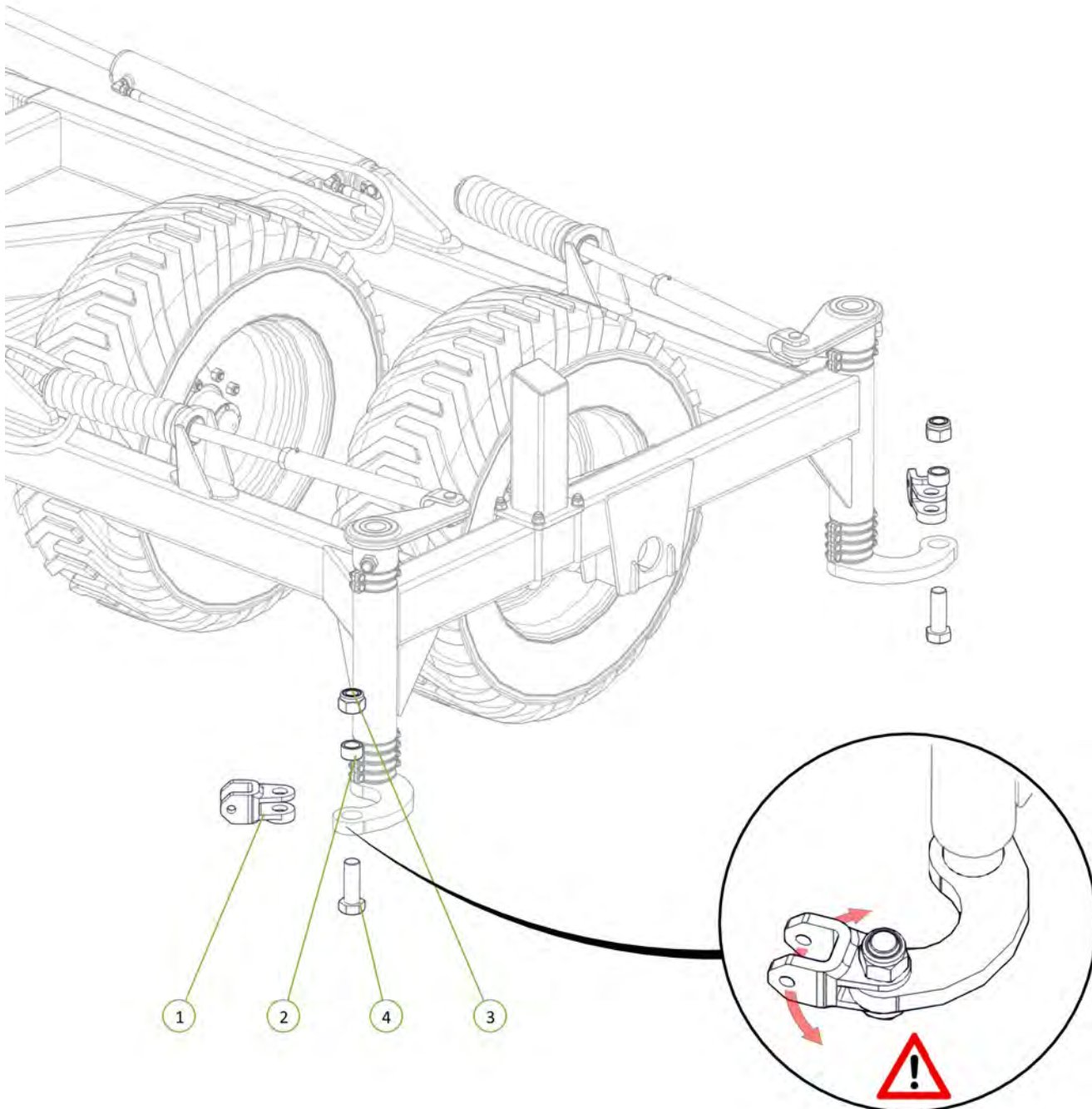

Ensure the clevis can pivot after installation

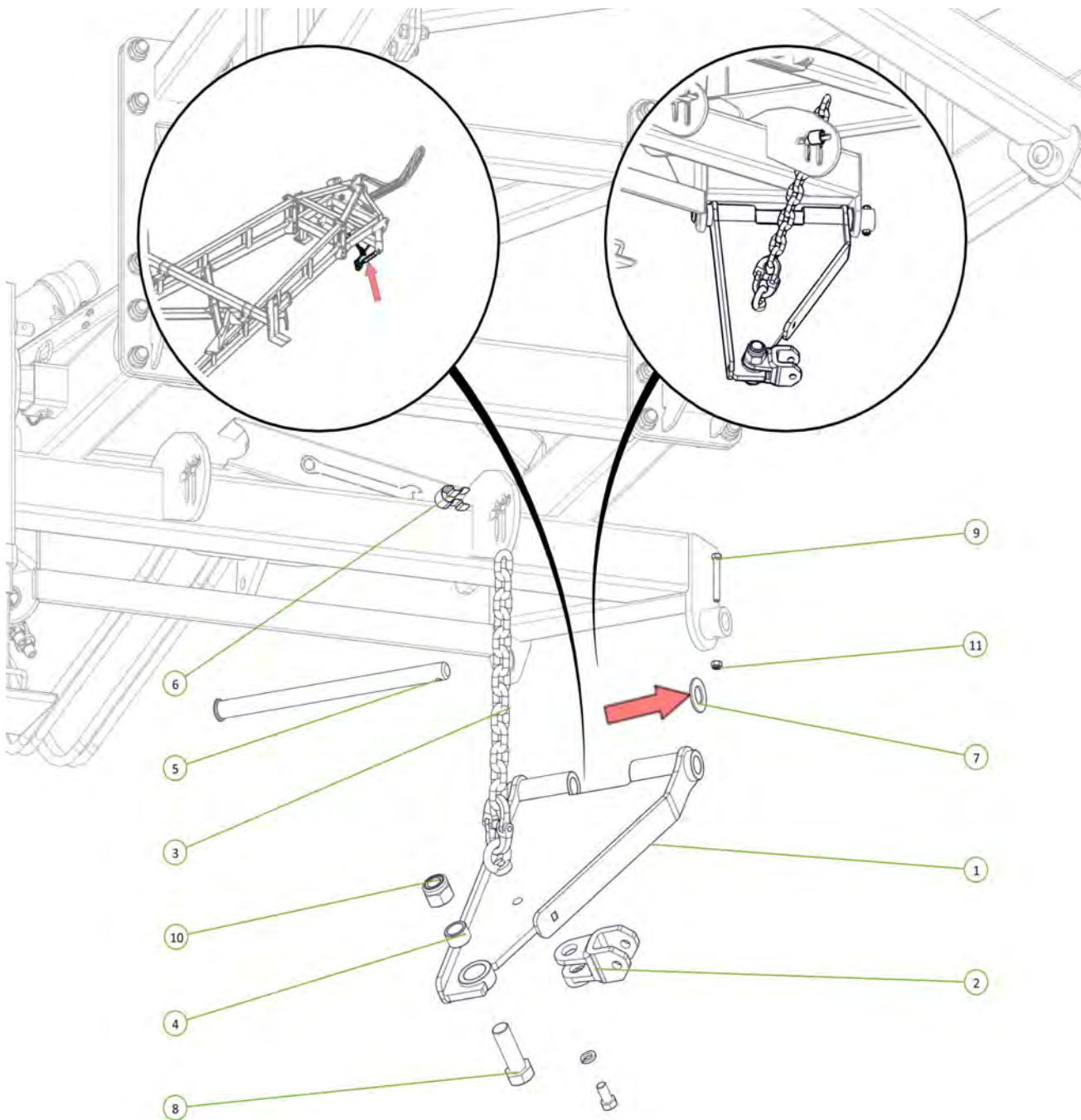

Ensure the clevis can pivot after installation

Item No.	Description	Number	Qty
1	Standard Chain Mount Plate	1610-20	1
2	Forged Clevis 21mm Bolt Hole	0801-FC21	1
3	Height Adjusting Chain Assembly 13 Link	0801-20MCA	1
4	Stainless Steel Wear Bush	1501-365033-SS	1
5	Chain Mount Pivot Pin	0801-10-51	1
6	Height Adjustor Retaining Clip	0801-KE014	1
7	Washer High Tensile 1 3/8"	0232-HT13-8	1
8	M36 x 105 grade 8.8 zp Bolt	0211-36105	1
9	M12 x 90 Class 8.8 ZP Bolt	0211-1290	1
10	Nyloc Nut M36	0221-NYL36	1
11	Nyloc Nut M12	0221-NYL12	1



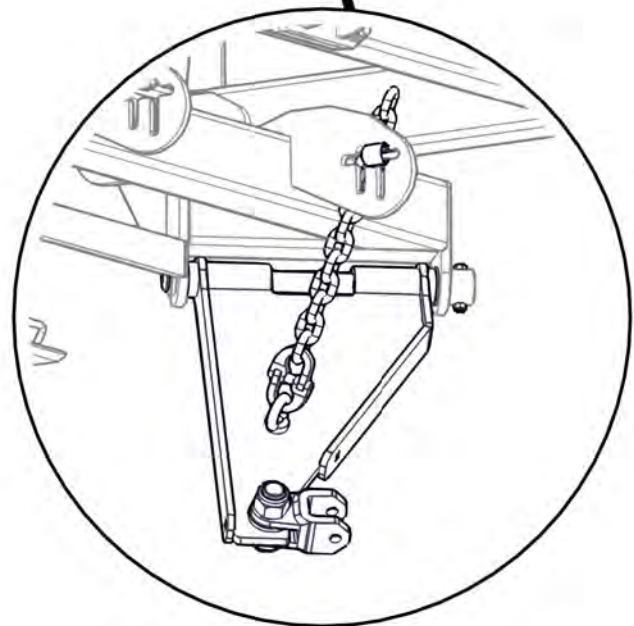
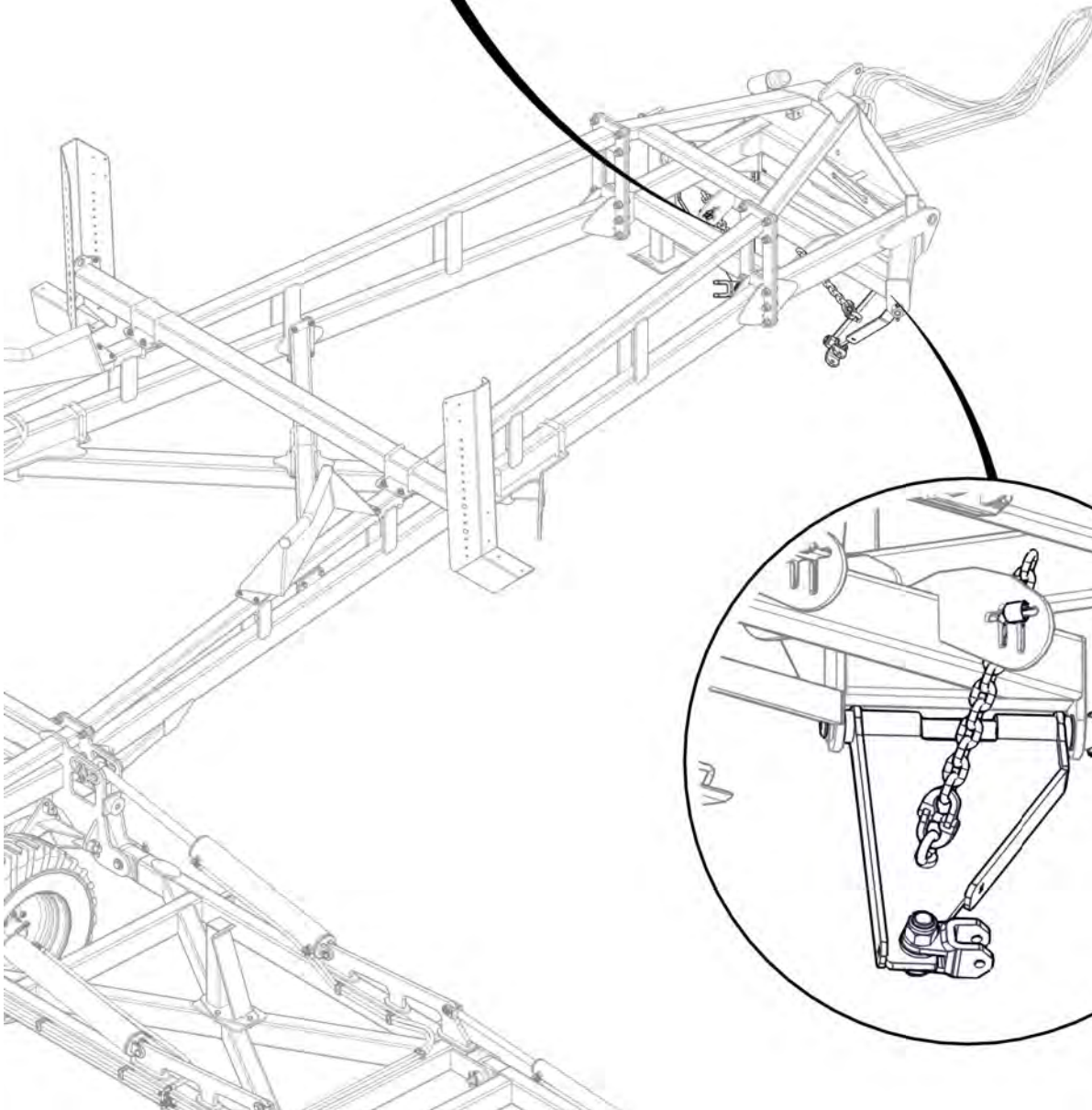
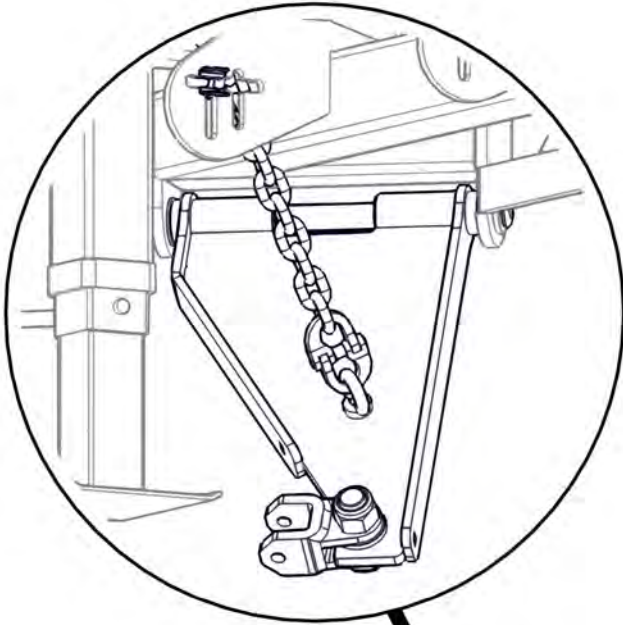

Item No.	Description	Number	Qty
1	Tension Box	0810-57	1
2	Module Tension Rod Assembly	0810-105A	1
3	Heavy Duty Coil Spring 24mm	0801-K2455350	1
4	Rigid Spring Locator	0801-10-S2L	1
5	Height Adjusting Chain Assembly 13 Link	0801-20MCA	1
6	Washer High Tensile 1 1/4"	0232-HT11-4	1
7	Washer Flat 1"	0232-F1	1

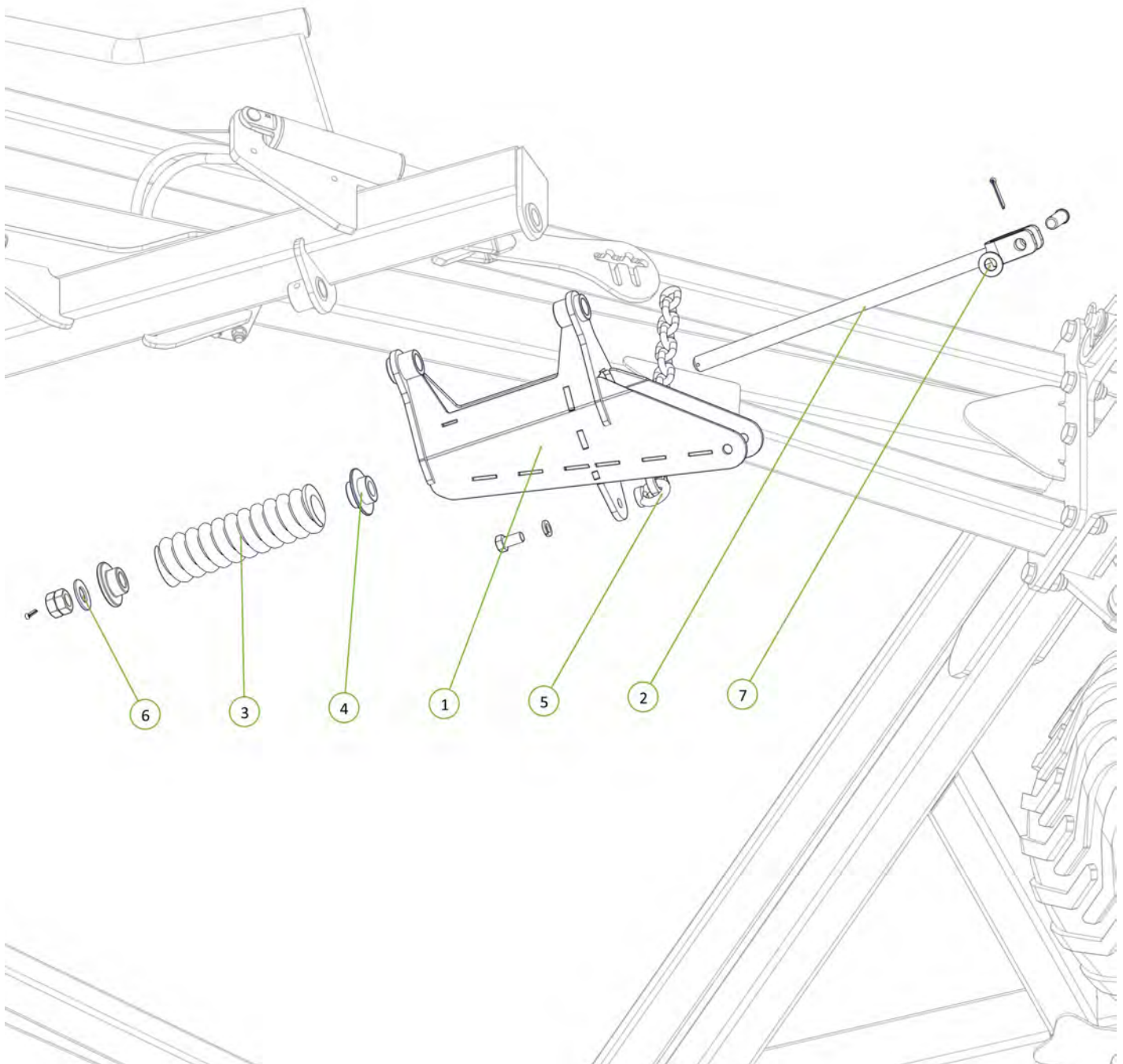

Item No.	Description	Number	Qty
1	Module Tension Arm No Clevis	0810-104	1
2	Forged Clevis 21mm Bolt Hole	0801-FC21	1
3	M36 x 105 Class 8.8 ZP Bolt	0211-36105	1
4	Module Pivot Arm Bush	0801-10-110	1
5	Nyloc Nut M36	0221-NYL36	1
6	M20 x 160 Grade 8.8 ZP Bolt	0211-20160	1
7	Nyloc Nut M20	0221-NYL20	1
8	Wear Bush	1501-365033-SS	1
9	35 ID x 50mm DU Bush	0113-MB3550DU	2
10	Washer Flat M20	0231-F20	2

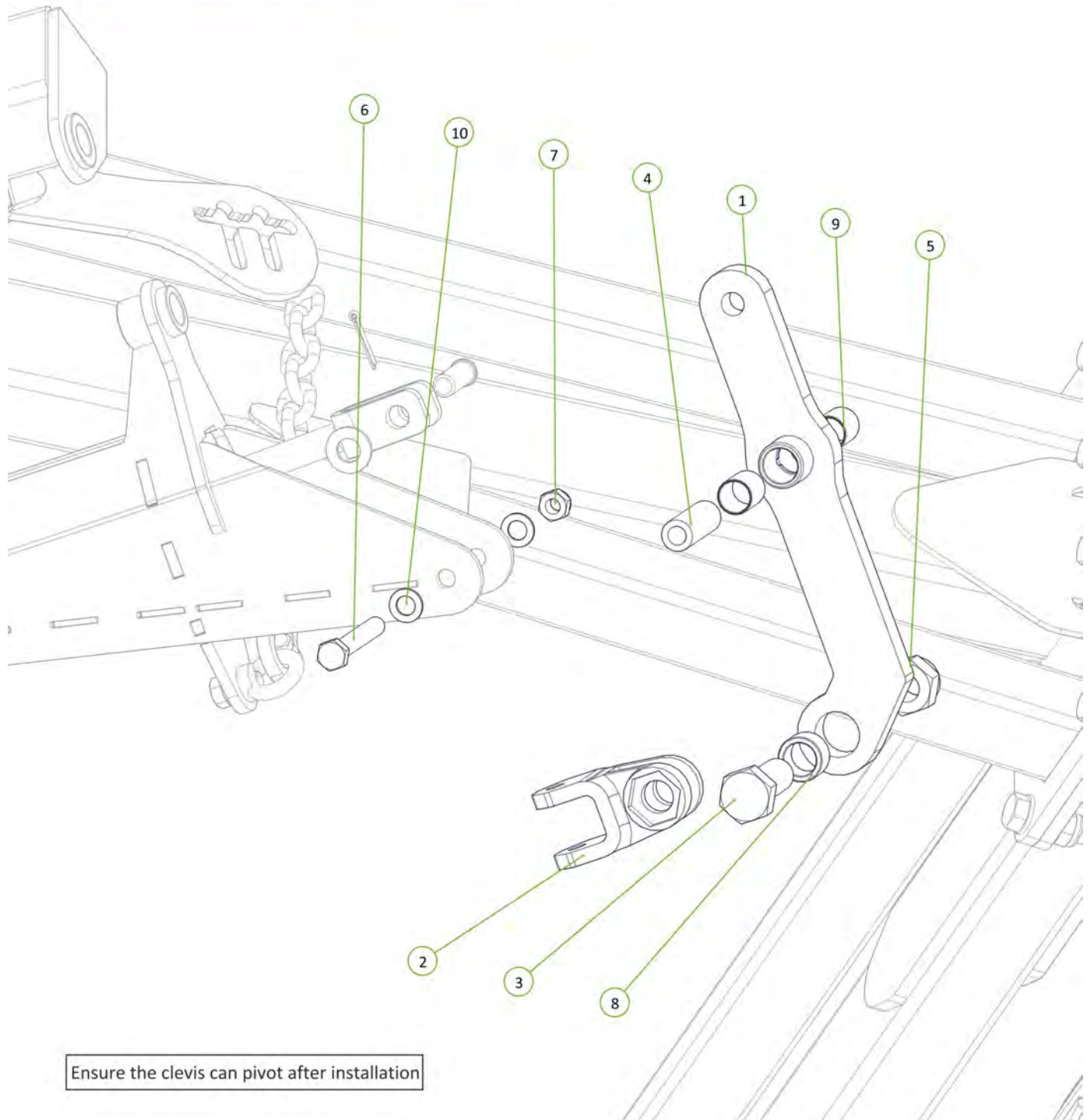

Item No.	Description	Number	Qty
1	Chain Mount Pivot Pin	0801-10-51	1
2	M12 x 90 Class 8.8 ZP Bolt	0211-1290	1
3	Nyloc Nut M12	0221-NYL12	1
4	Washer High Tensile 1 3/8"	0232-HT13-8	1
5	Height Adjustor Retaining Clip	0801-KE014	1

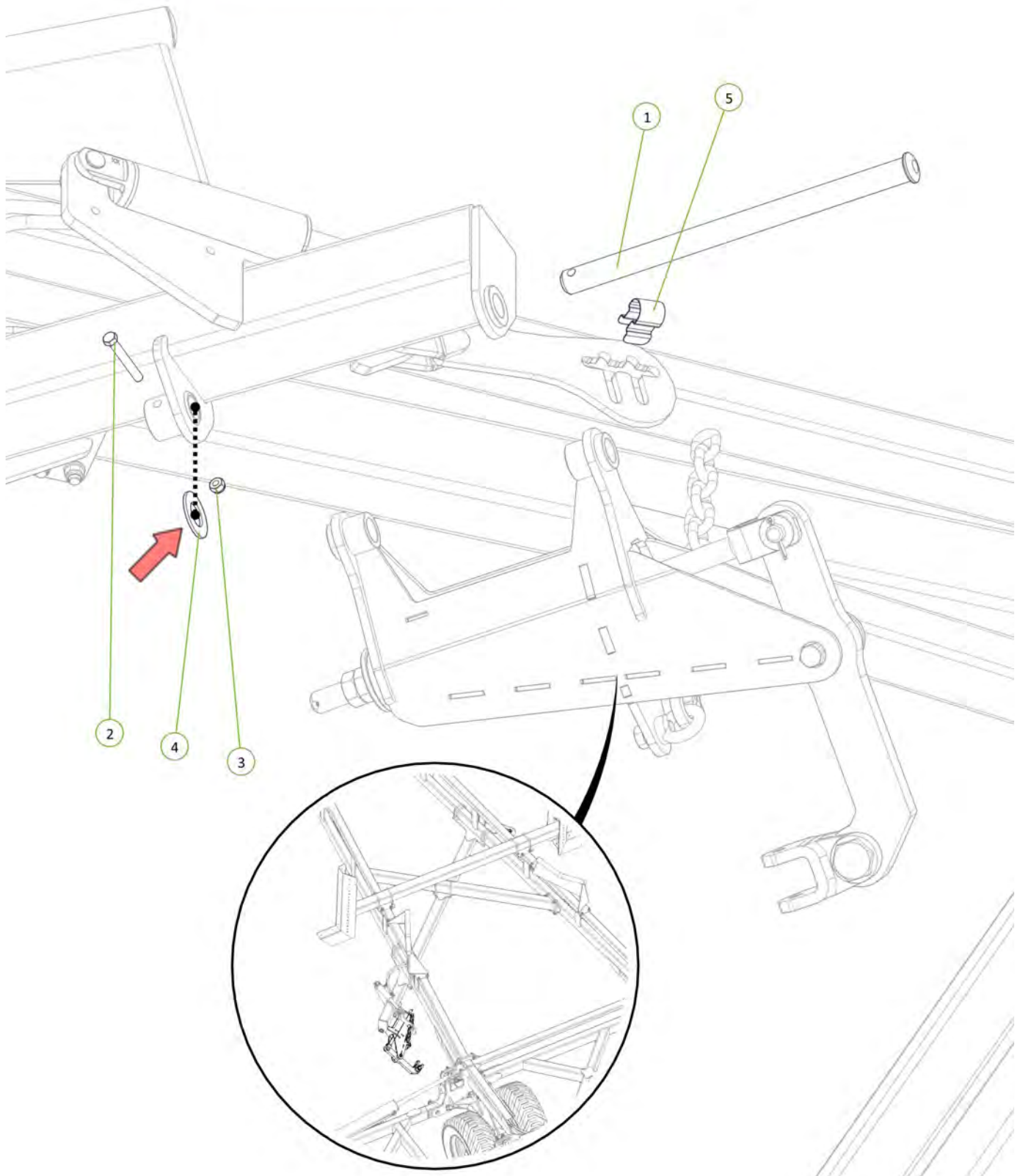

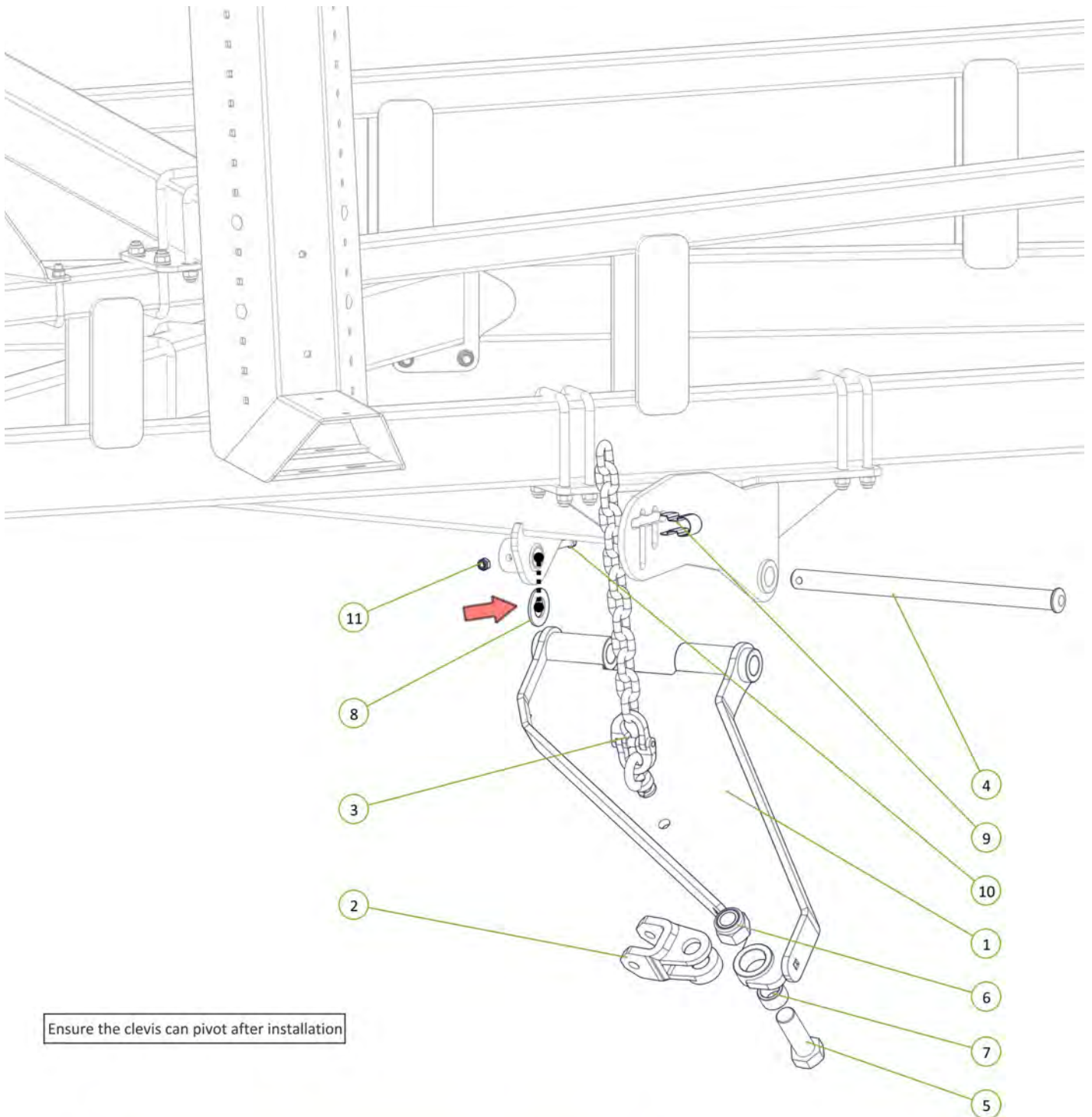

Ensure the clevis can pivot after installation

Item No.	Description	Number	Qty
1	Extended Chain Mount Plate	1610-21	1
2	Forged Clevis 21mm Bolt Hole	0801-FC21	1
3	Height Adjusting Chain Assembly 13 Link	0801-20MCA	1
4	Chain Mount Pivot Pin	0801-10-51	1
5	M36 x 105 Class 8.8 ZP Bolt	0211-36105	1
6	Nyloc Nut M36	0221-NYL36	1
7	Wear Bush	1501-365033-SS	1
8	Washer High Tensile 1 3/8"	0232-HT13-8	1
9	Height Adjustor Retaining Clip	0801-KE014	1
10	M12 x 90 Class 8.8 ZP Bolt	0211-1290	1
11	Nyloc Nut M12	0221-NYL12	1



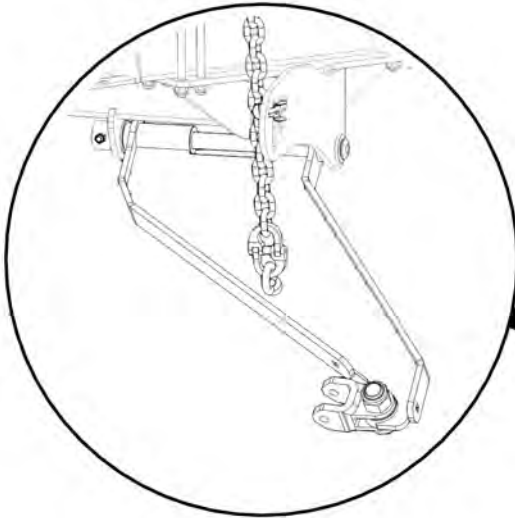

1610-28-46A-2-AS2

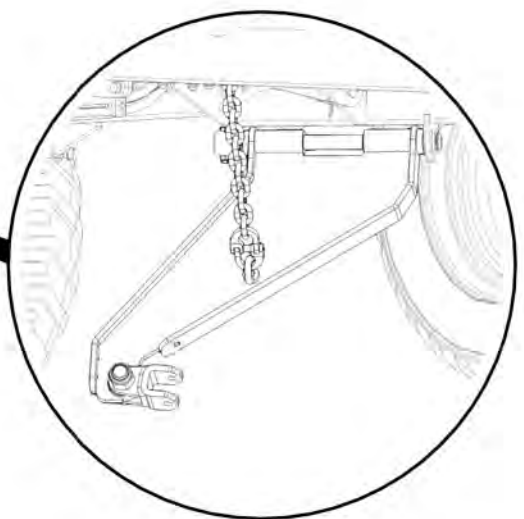
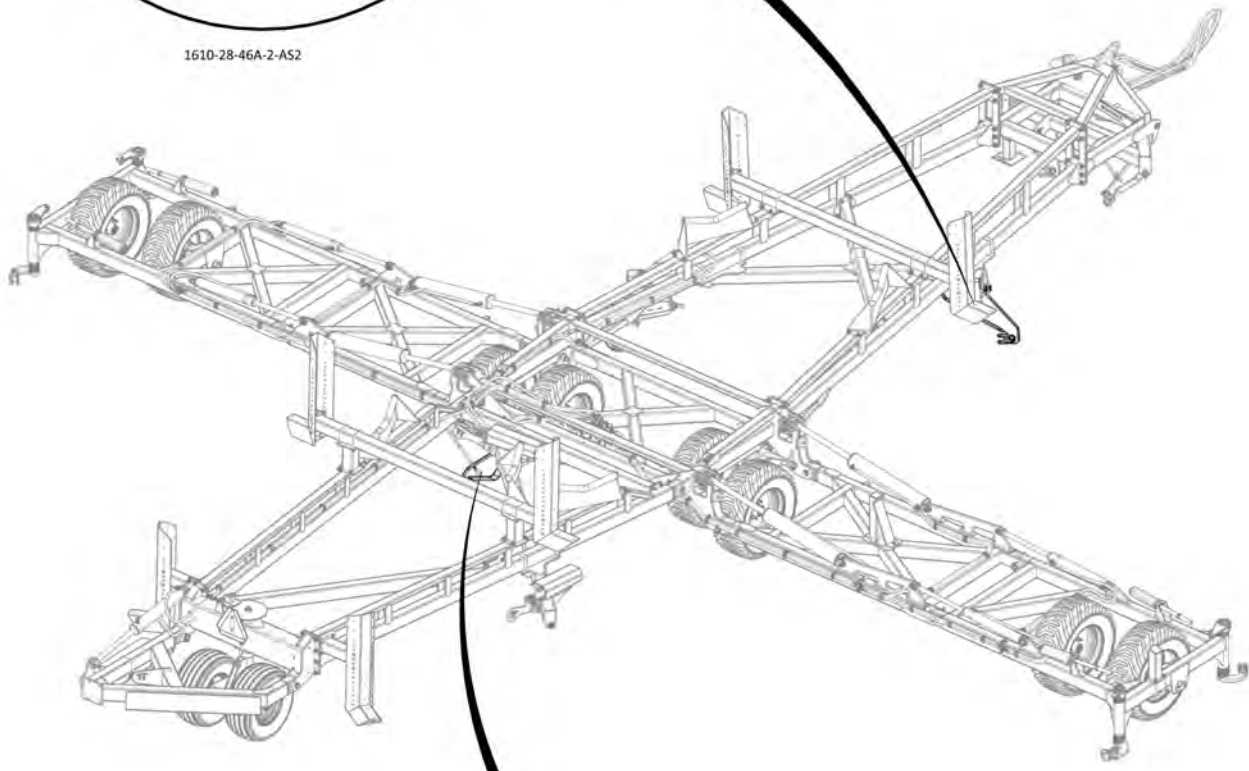

1610-29-46A-2-AS2

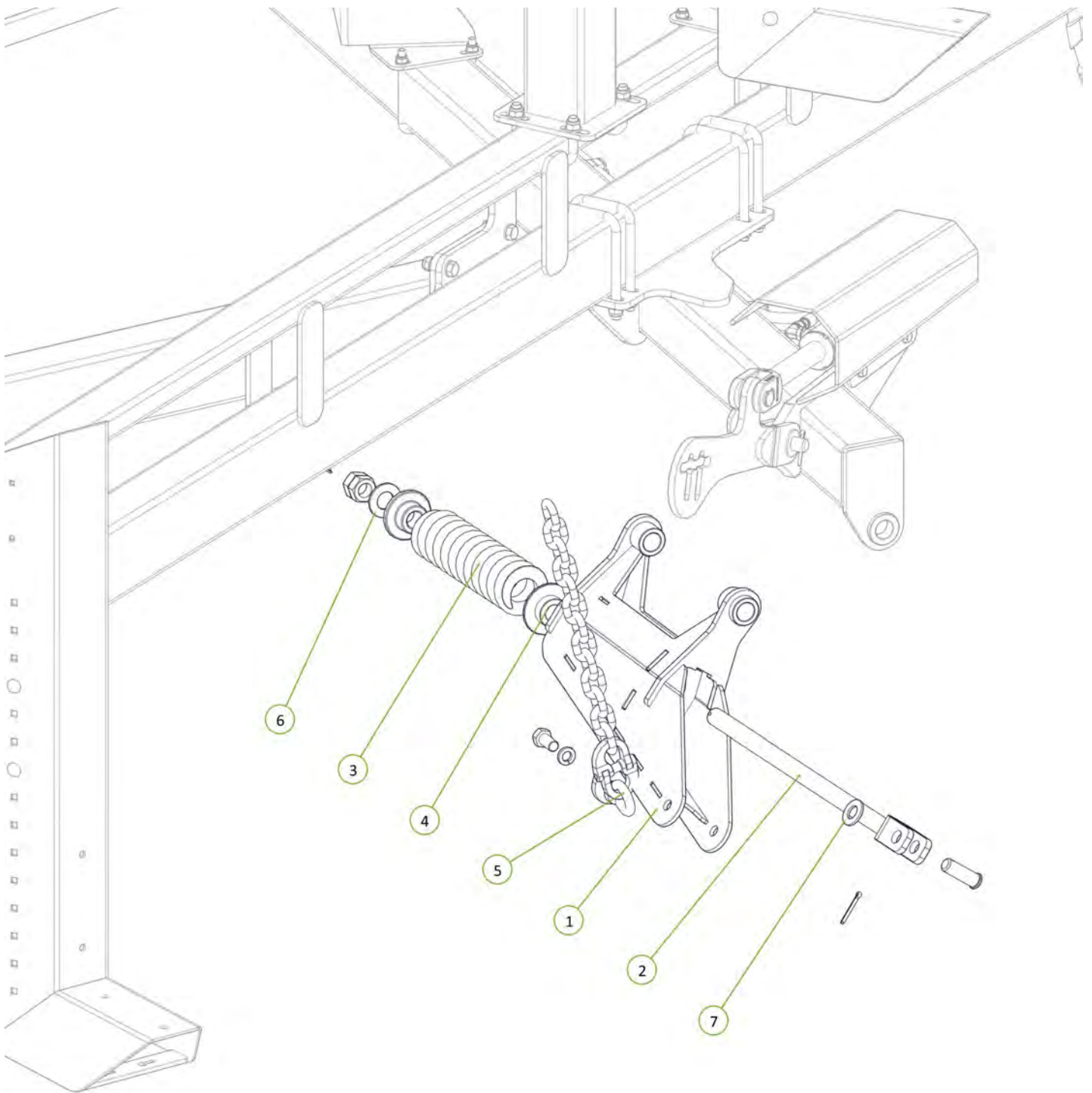

Item No.	Description	Number	Qty
1	Tension Box	0810-57	1
2	Module Tension Rod Assembly	0810-105A	1
3	Heavy Duty Coil Spring 24mm	0801-K2455350	1
4	Rigid Spring Locator	0801-10-S2L	1
5	Height Adjusting Chain Assembly 13 Link	0801-20MCA	1
6	Washer High Tensile 1 1/4"	0232-HT11-4	1
7	Washer Flat 1"	0232-F1	1

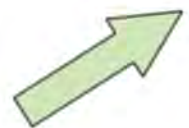

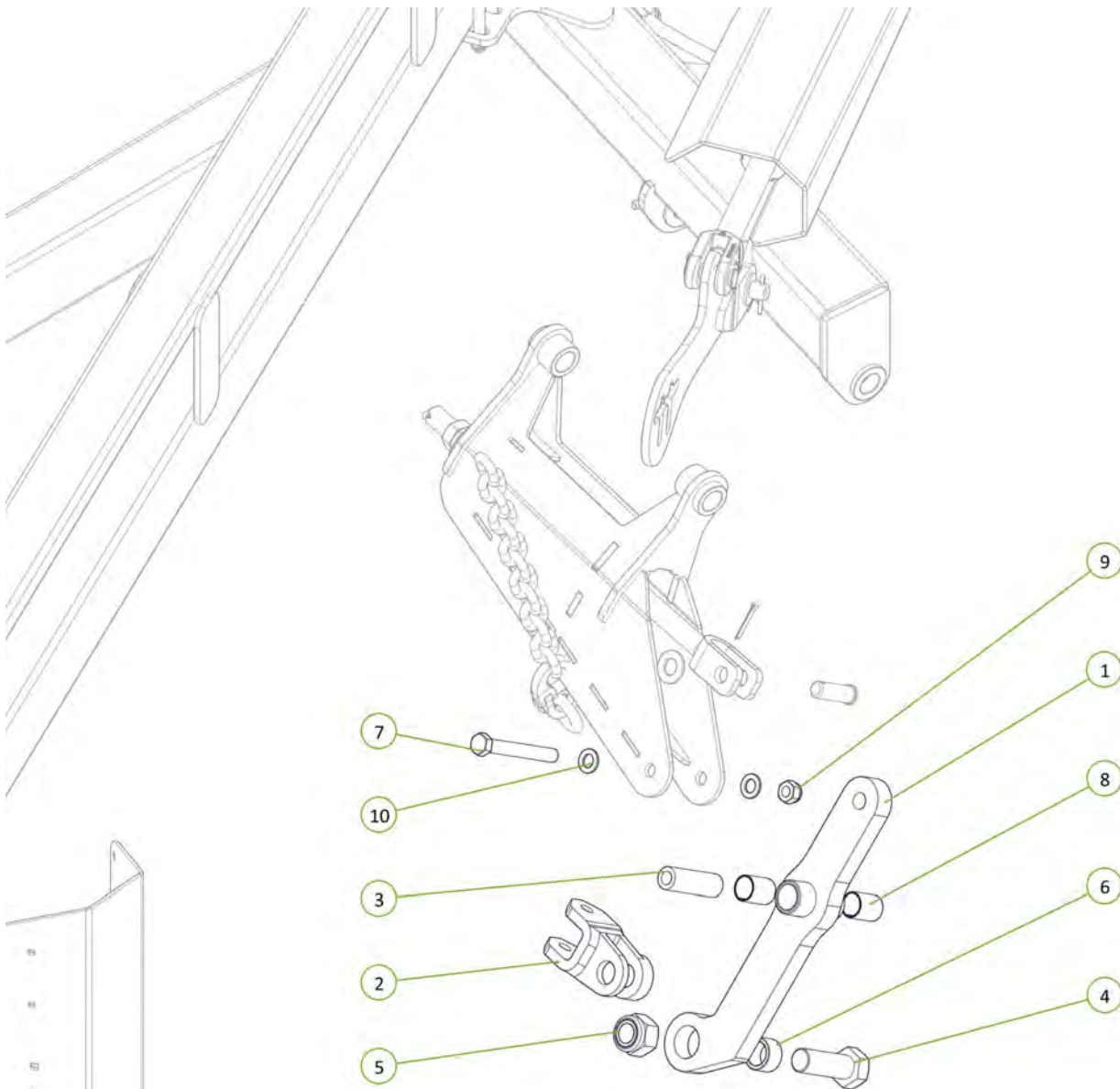

Ensure the clevis can pivot after installation

Item No.	Description	Number	Qty
1	Module Tension Arm No Clevis	0810-104	1
2	Forged Clevis 21mm Bolt Hole	0801-FC21	1
3	Module Pivot Arm Bush	0801-10-110	1
4	M36 x 105 Class 8.8 ZP Bolt	0211-36105	1
5	Nyloc Nut M36	0221-NYL36	1
6	Wear Bush	1501-365033-SS	1
7	M20 x 160 Grade 8.8 ZP Bolt	0211-20160	1
8	35 ID x 50mm DU Bush	0113-MB3550DU	2
9	Nyloc Nut M20	0221-NYL20	1
10	Washer Flat M20	0231-F20	2



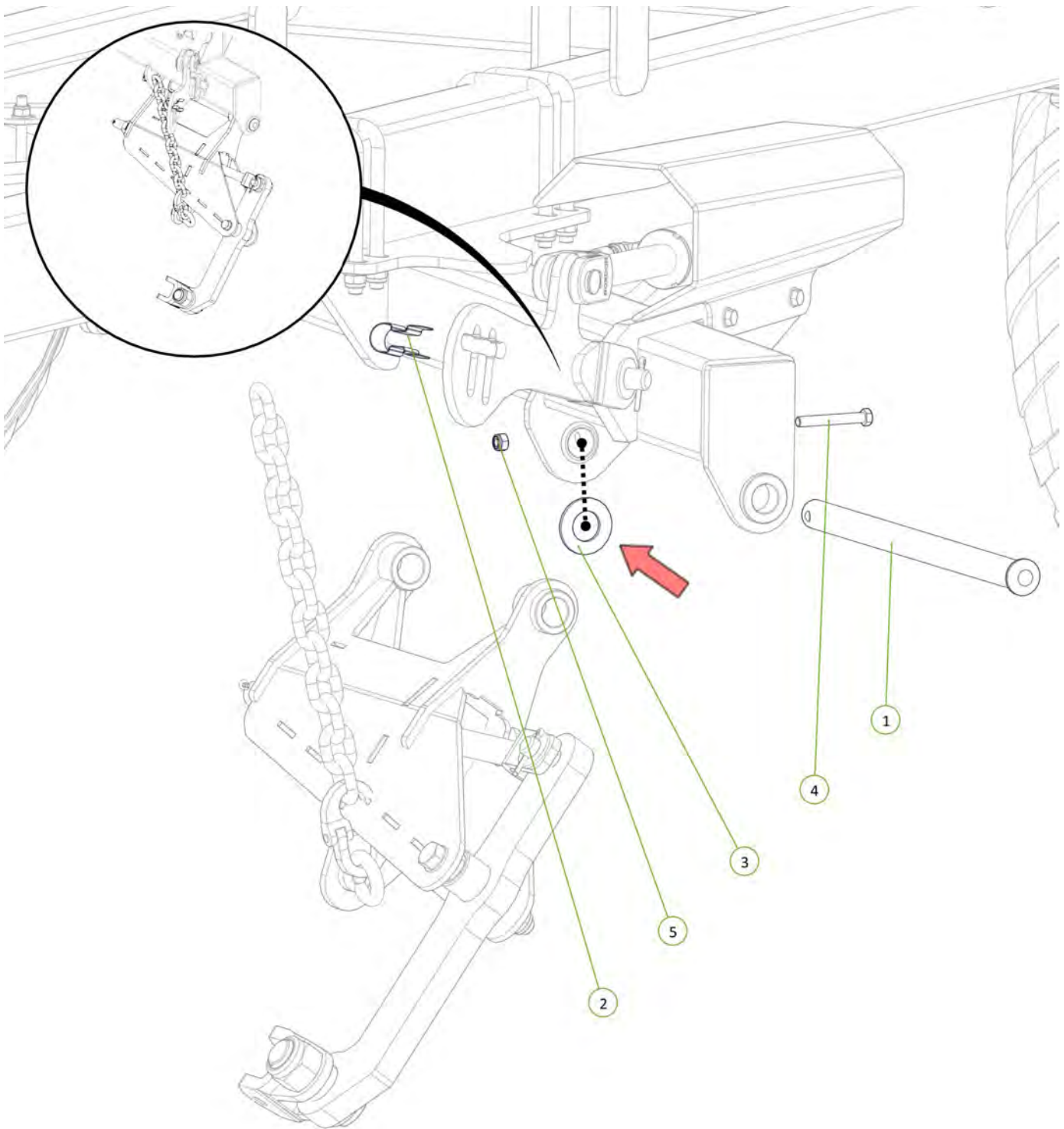

Item No.	Description	Number	Qty
1	Chain Mount Pivot Pin	0801-10-51	1
2	Height Adjustor Retaining Clip	0801-KE014	1
3	Washer High Tensile 1 3/8"	0232-HT13-8	1
4	M12 x 90 Class 8.8 ZP Bolt	0211-1290	1
5	Nyloc Nut M12	0221-NYL12	1



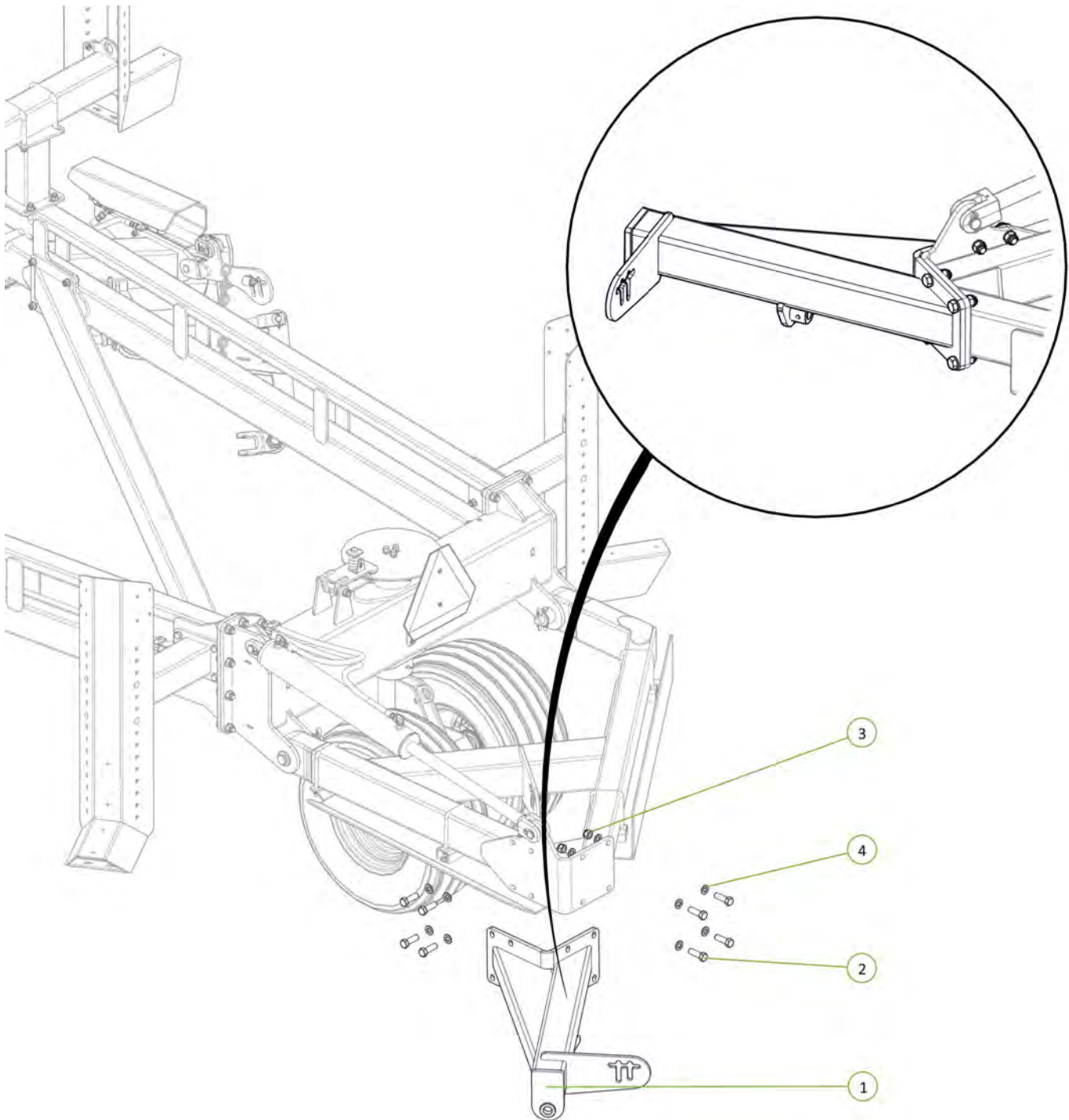

Item No.	Description	Number	Qty
1	Tail Extension	1510-40ST	1
2	M20 x 65 Grade 8.8 ZP Bolt	0211-2065	8
3	Nyloc Nut M20	0221-NYL20	8
4	Washer Flat M20	0231-F20	16



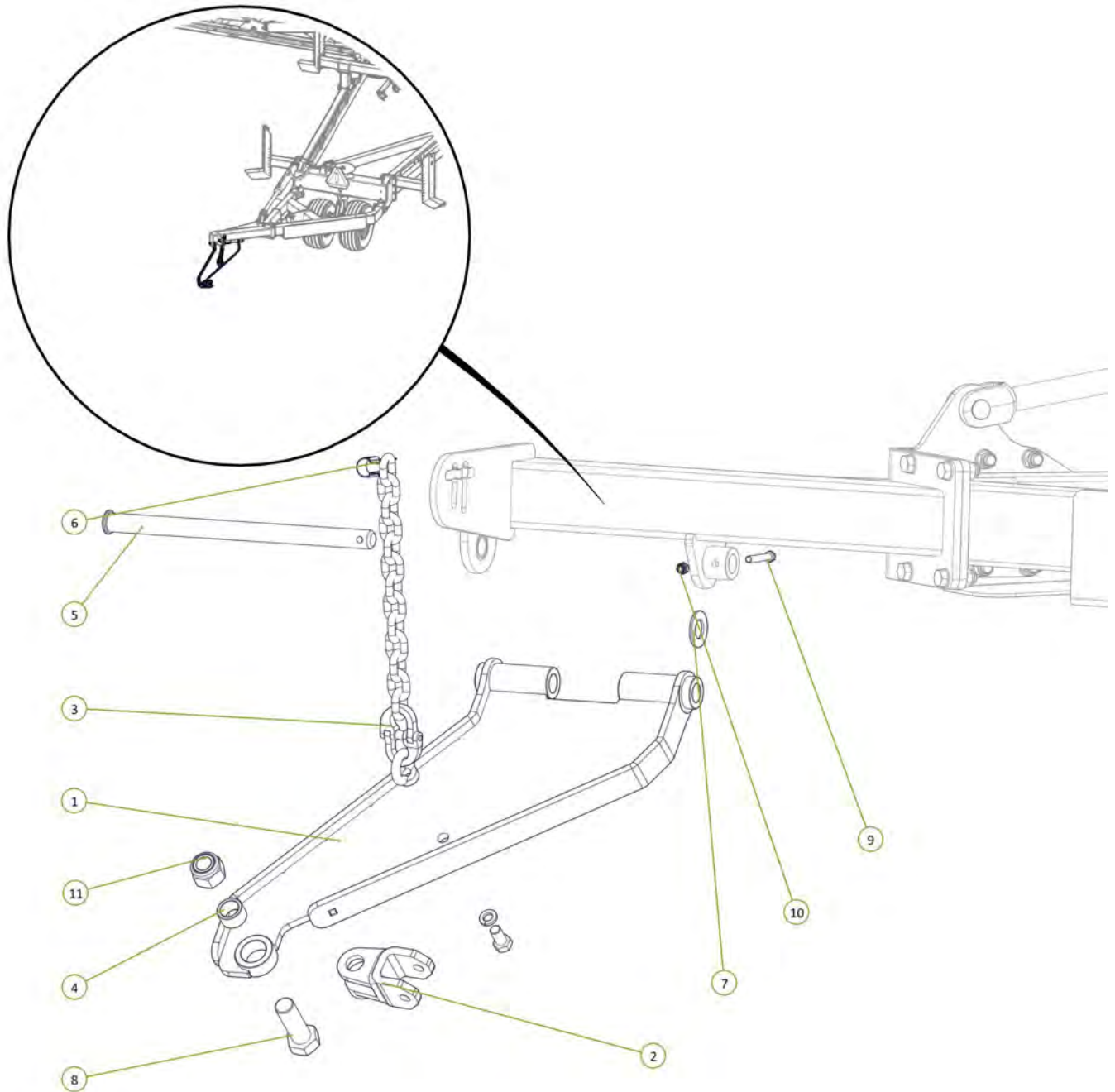

Item No.	Description	Number	Qty
1	Extended Chain Mount Plate	1610-21	1
2	Forged Clevis 21mm Bolt Hole	0801-FC21	1
3	Height Adjusting Chain Assembly 13 Link	0801-20MCA	1
4	Stainless Steel Wear Bush	1501-365033-SS	1
5	Chain Mount Pivot Pin	0801-10-51	1
6	Height Adjustor Retaining Clip	0801-KE014	1
7	Washer High Tensile 1 3/8"	0232-HT13-8	1
8	M36 x 105 grade 8.8 zp Bolt	0211-36105	1
9	M12 x 90 Class 8.8 ZP Bolt	0211-1290	1
10	Nyloc Nut M12	0221-NYL12	1
11	Nyloc Nut M36	0221-NYL36	1

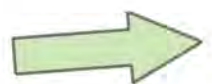

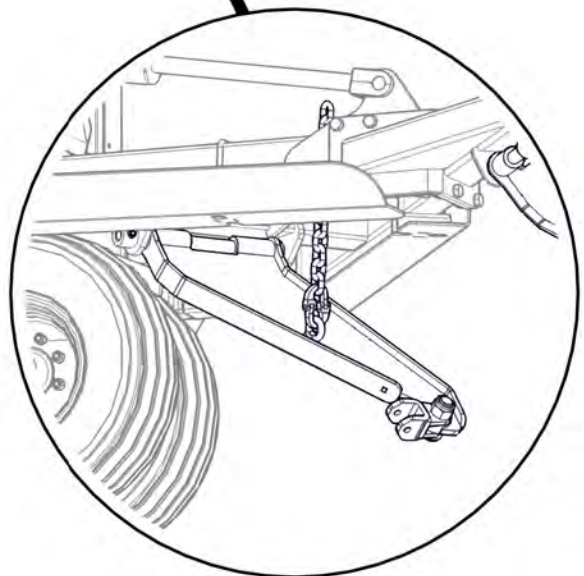
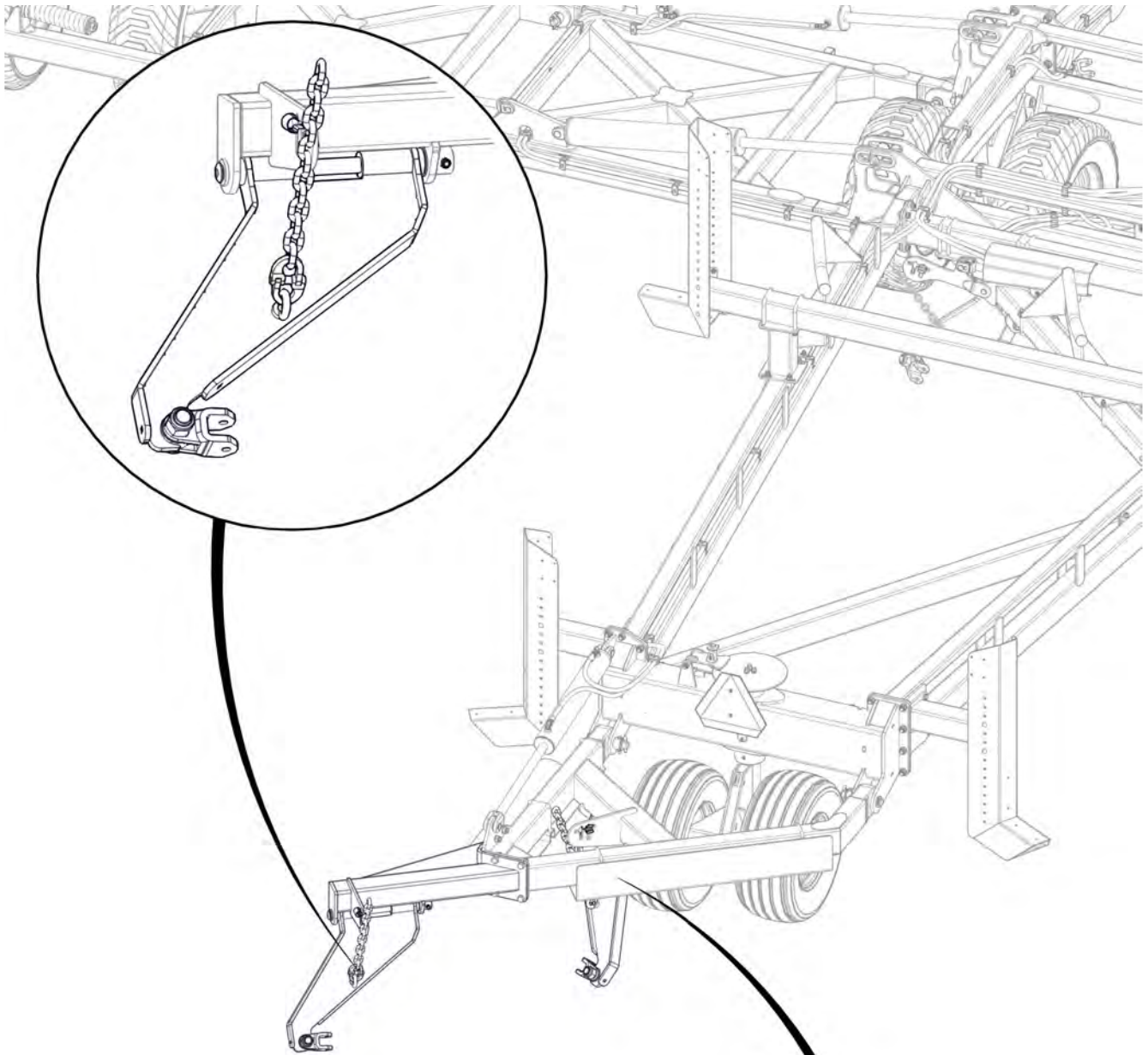

Item No.	Description	Number	Qty
1	Drawbar	1610-08	1
2	PCH Wing Pivot Pin	0801-10-08-235	2
3	35 ID x 30mm DU Bush	0113-MB3530DU	4
4	M12 x 90 Class 8.8 ZP Bolt	0211-1290	2
5	Nyloc Nut M12	0221-NYL12	2
6	Cotter Pin M13 x 63	0261-PINC1363	2

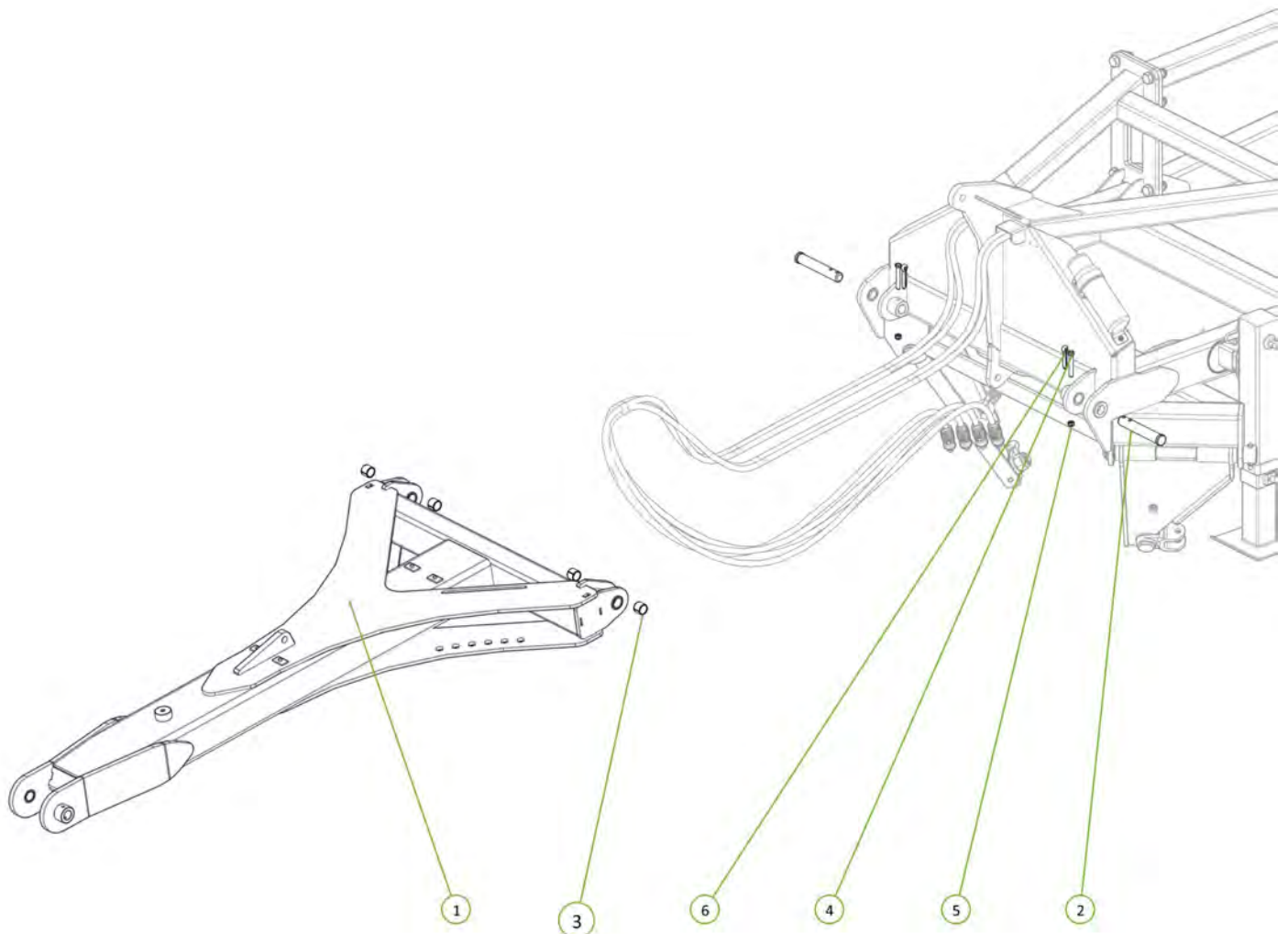
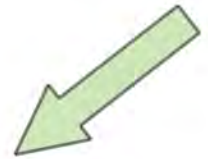

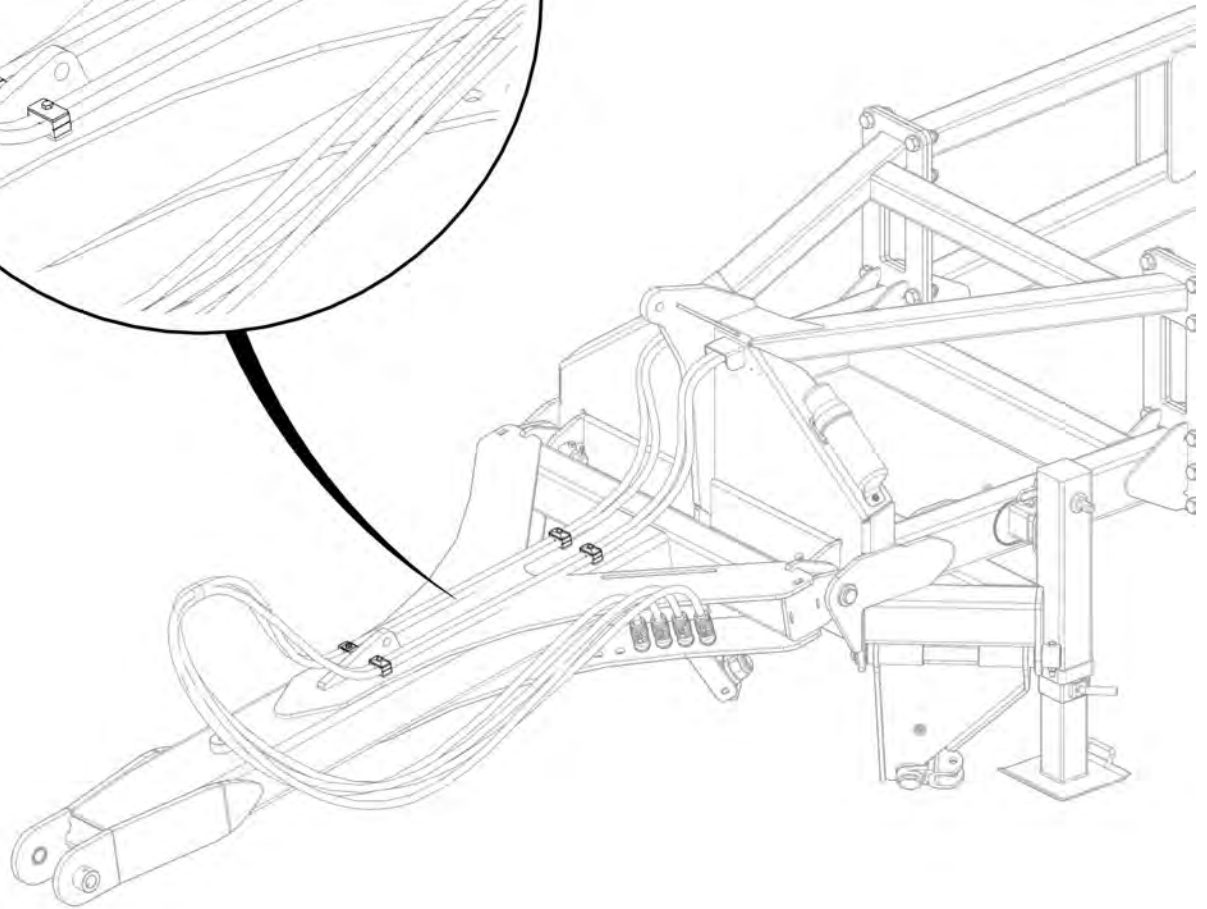
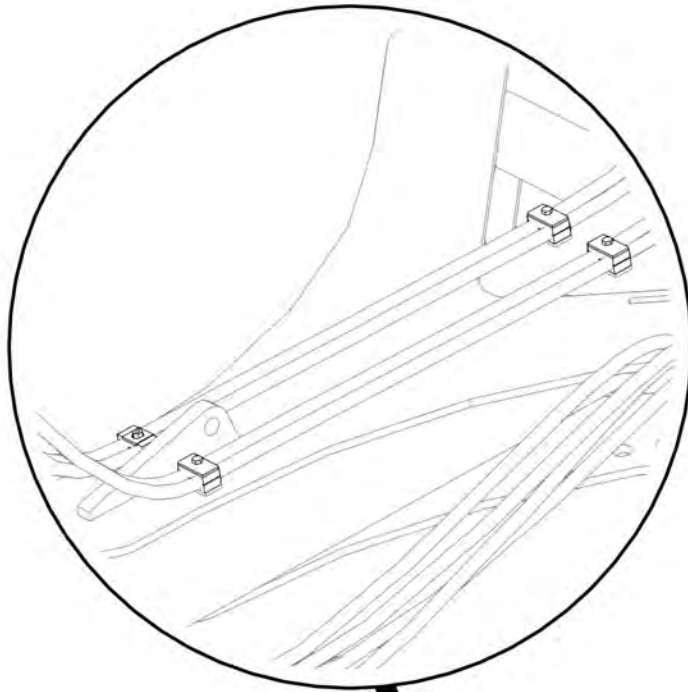
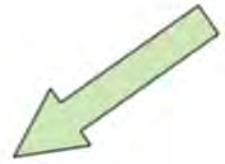

Item No.	Description	Number	Qty
1	Hose Post Spring	1601-CDB-00-0012	1
2	M16 x 35 grade 8.8 zp Bolt	0211-1635	1
3	Washer Spring M16	0231-S16	1
4	Washer Flat M16	0231-F16	1

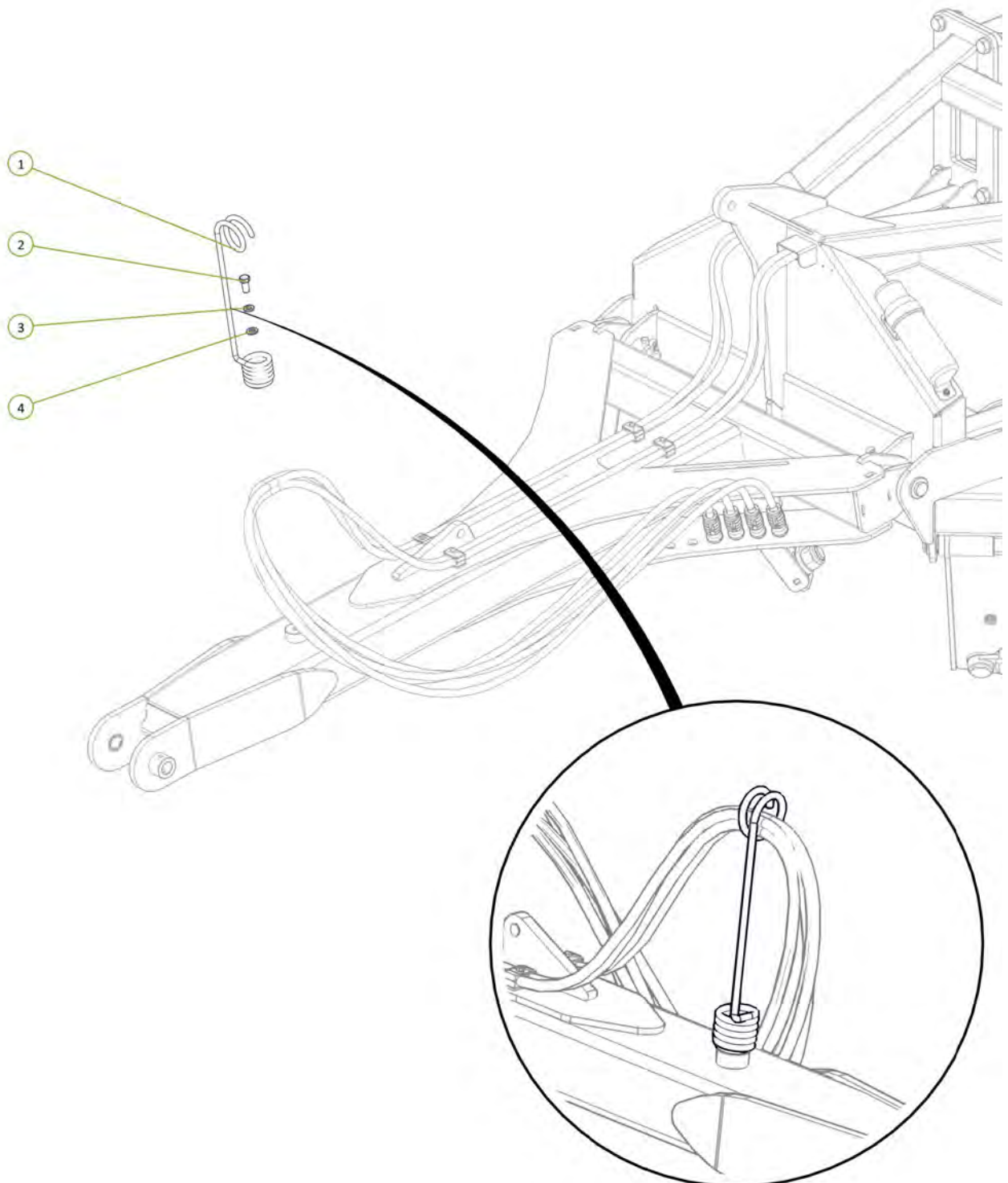

Item No.	Description	Number	Qty
1	4" Bore 12" Stroke 2" Rod Extended Hydraulic Cylinder	0311-412EXT-2	1

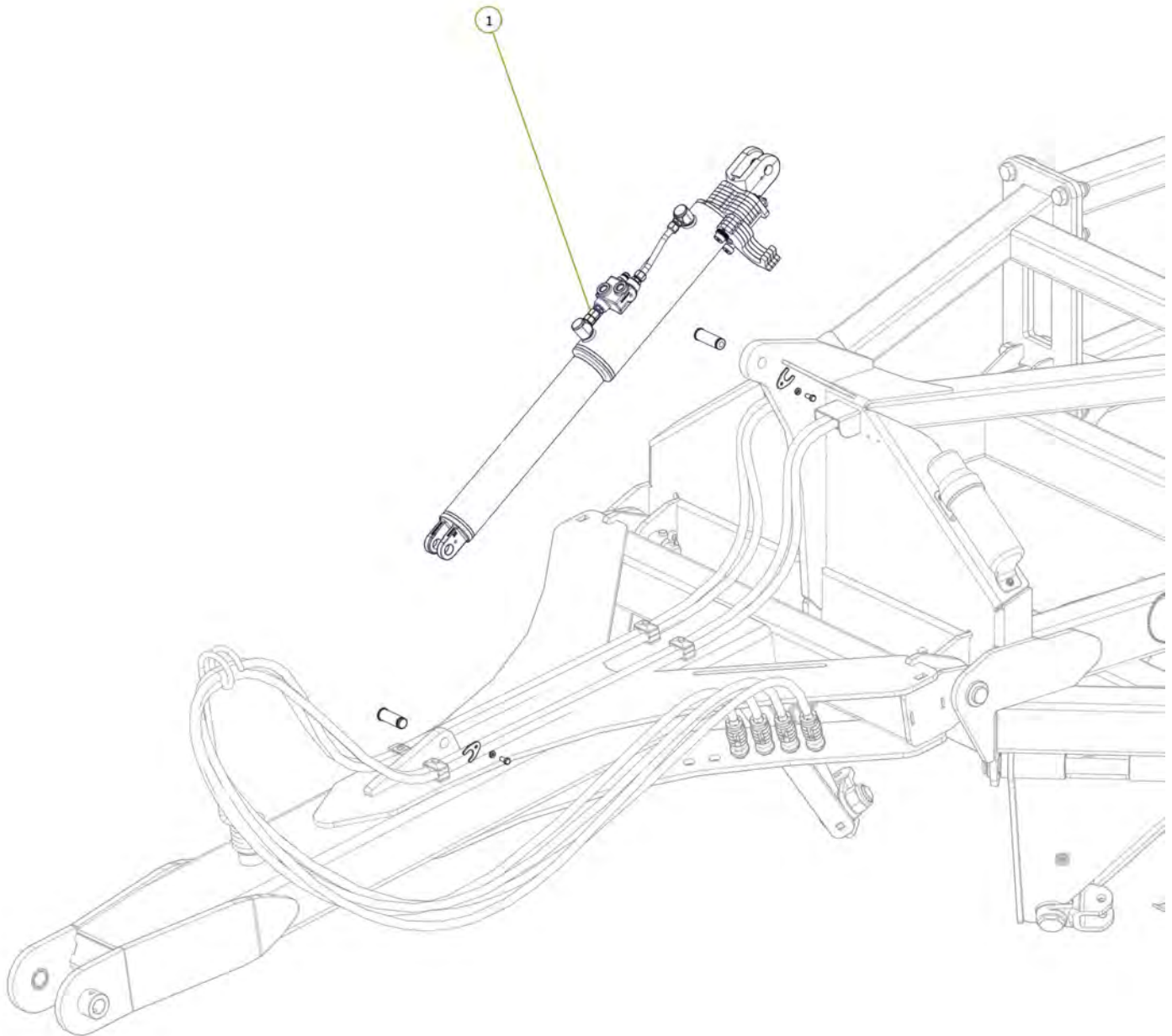

Item No.	Description	Number	Qty
1	3/4" JIC Male 3/4" UN O Ring Male 90° Elbow	0323-S91-1212	2

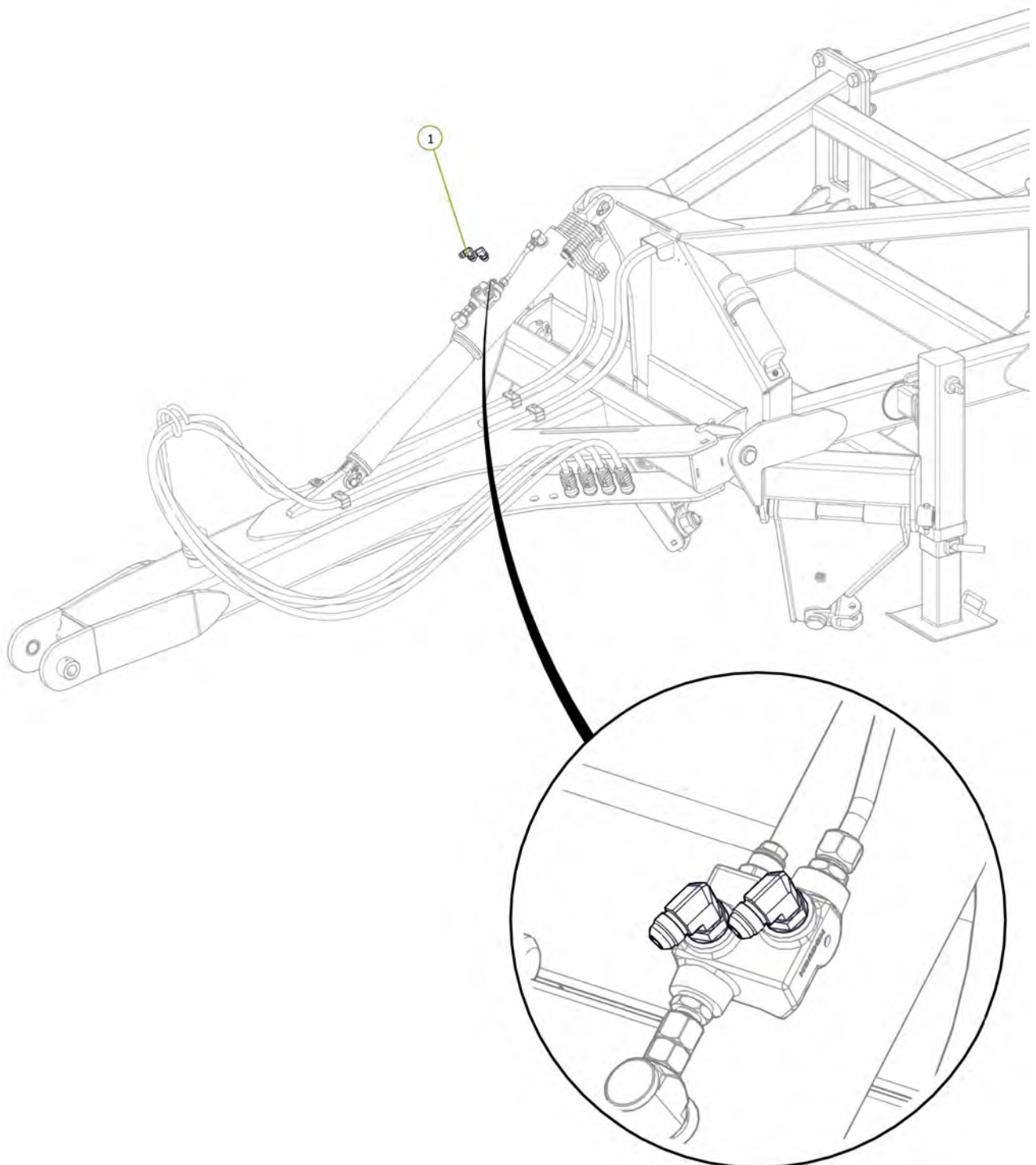
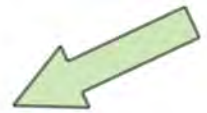

Item No.	Description	Number	Qty
1	Tractor to Front Lift Cylinder Extend Port Fitted With Blue EXT Grip	H46-2-05-BE-EXT	1
2	Tractor to Front Lift Cylinder Extend Port Fitted With Blue RTC Grip	H46-2-06-BR-RCT	1

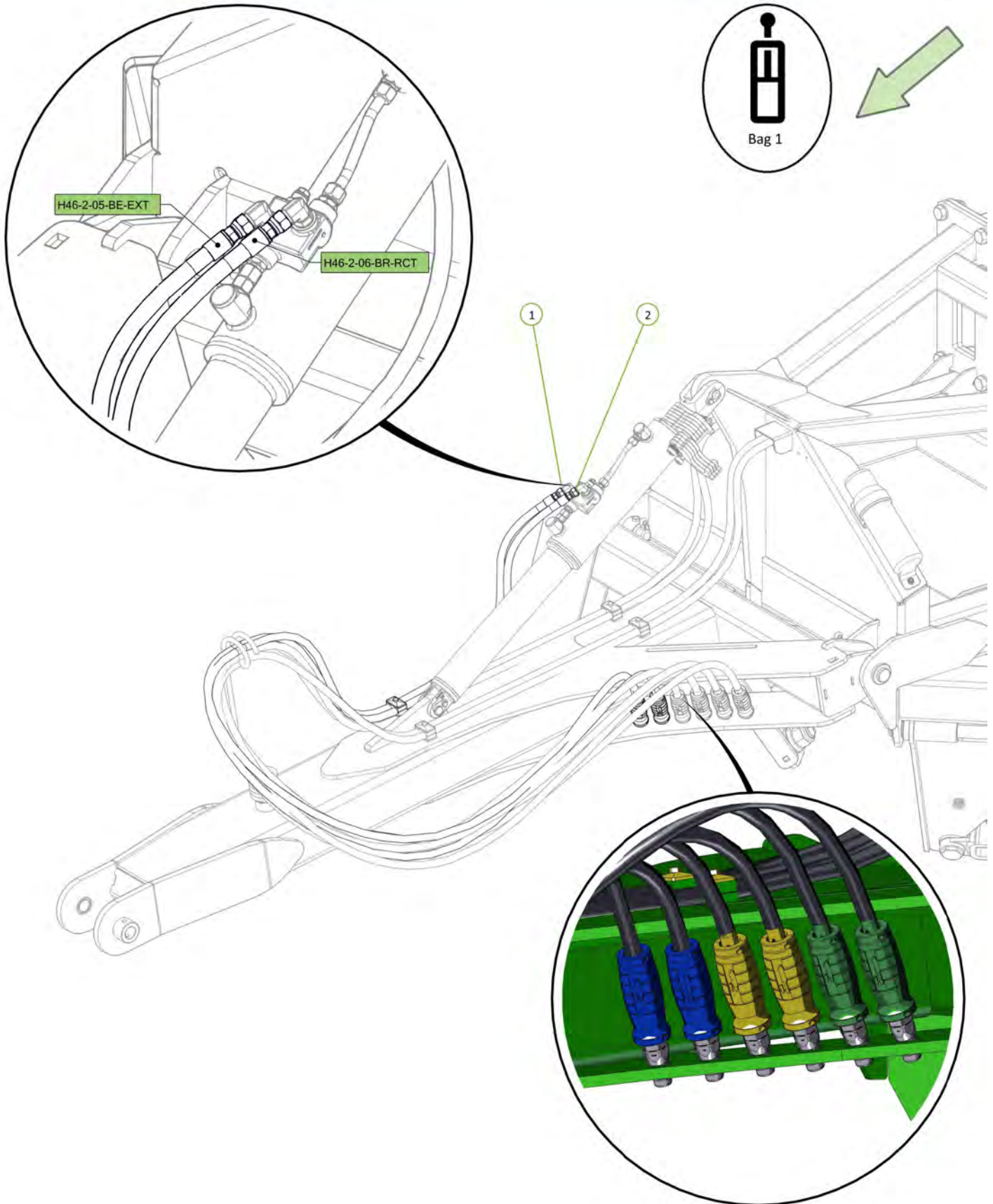

Item No.	Description	Number	Qty
1	Tow Hitch For Bull Pull Swivel Hitch	0810-09-BP	1
2	Bull Pull Swivel Hitch Cat 4 with 1-1/2" Insert	0801-BPF-CAT-4JDF-2	1
3	1" x 5-1/2" UNF Grade 8 ZP Bolt	0213-1 51-2	3
4	Nyloc Nut 1" UNF	0223-NYL1	3
5	35 ID x 50mm DX Bush	0113-MB3550DX	2
6	Grease Nipple 1/4" UNF 45°	0181-GN1-445	2

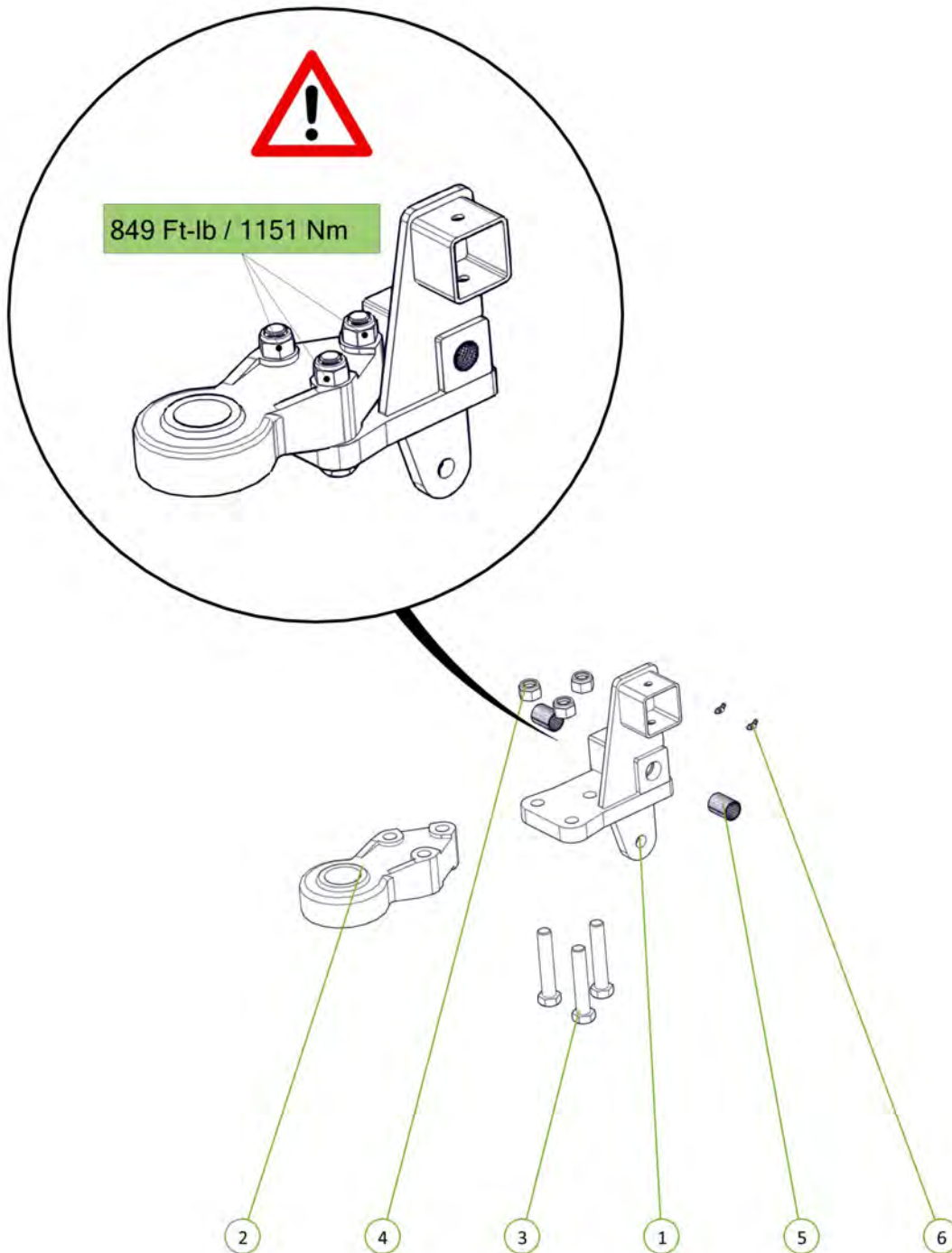

Item No.	Description	Number	Qty
1	Tow Hitch Pivot Pin	0801-10-14	1
2	M12 x 90 Class 8.8 ZP Bolt	0211-1290	2
3	Nyloc Nut M12	0221-NYL12	2

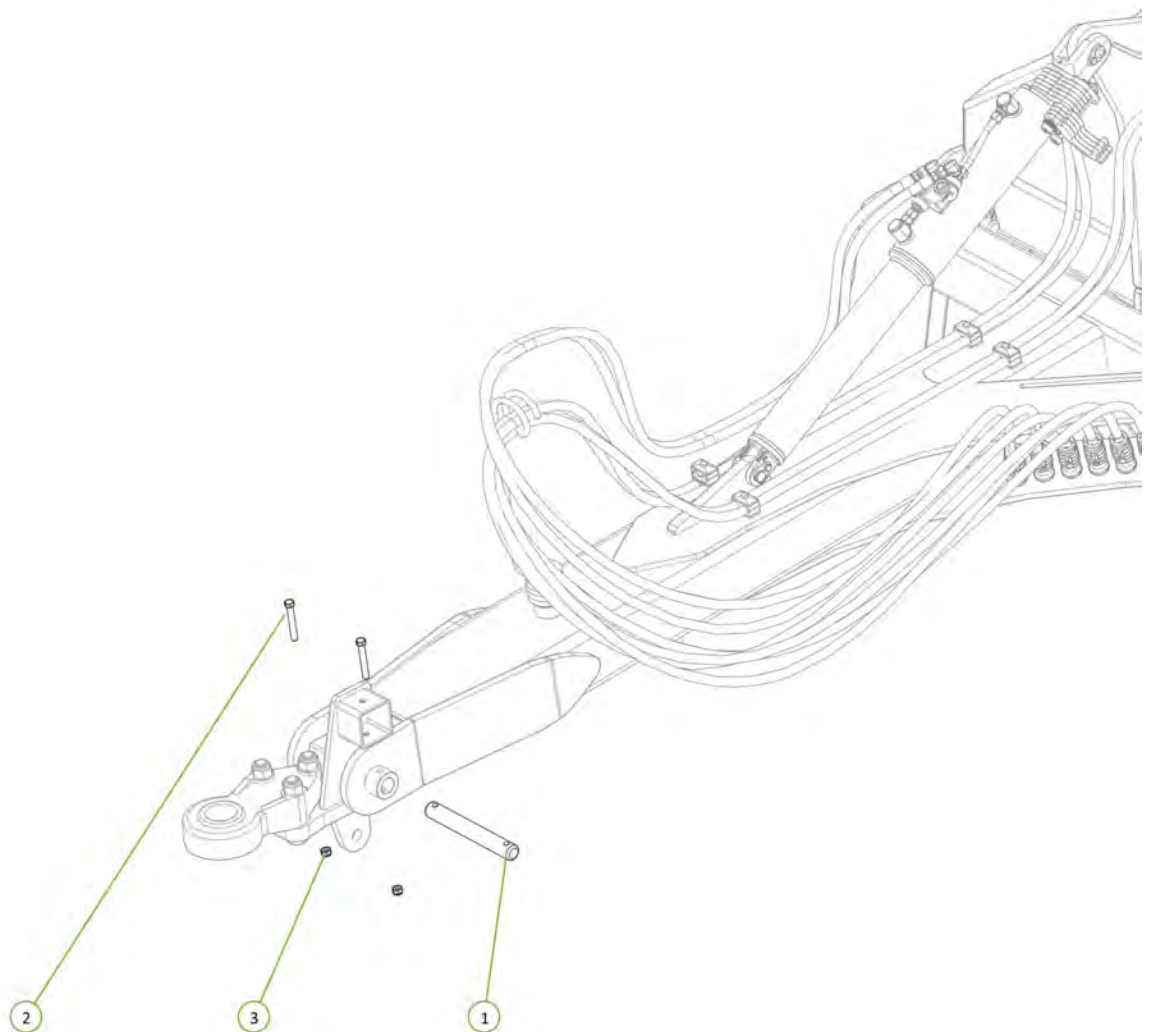
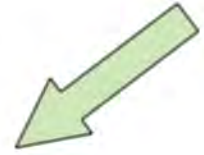

Item No.	Description	Number	Qty
1	46' Parallel Arm	0810-64	1
2	Clevis Pin 25mm x 75mm	0801-KE0307-1	2
3	Washer Flat 1"	0232-F1	2
4	Cotter Pin M5 x 50	0261-PINC550	2

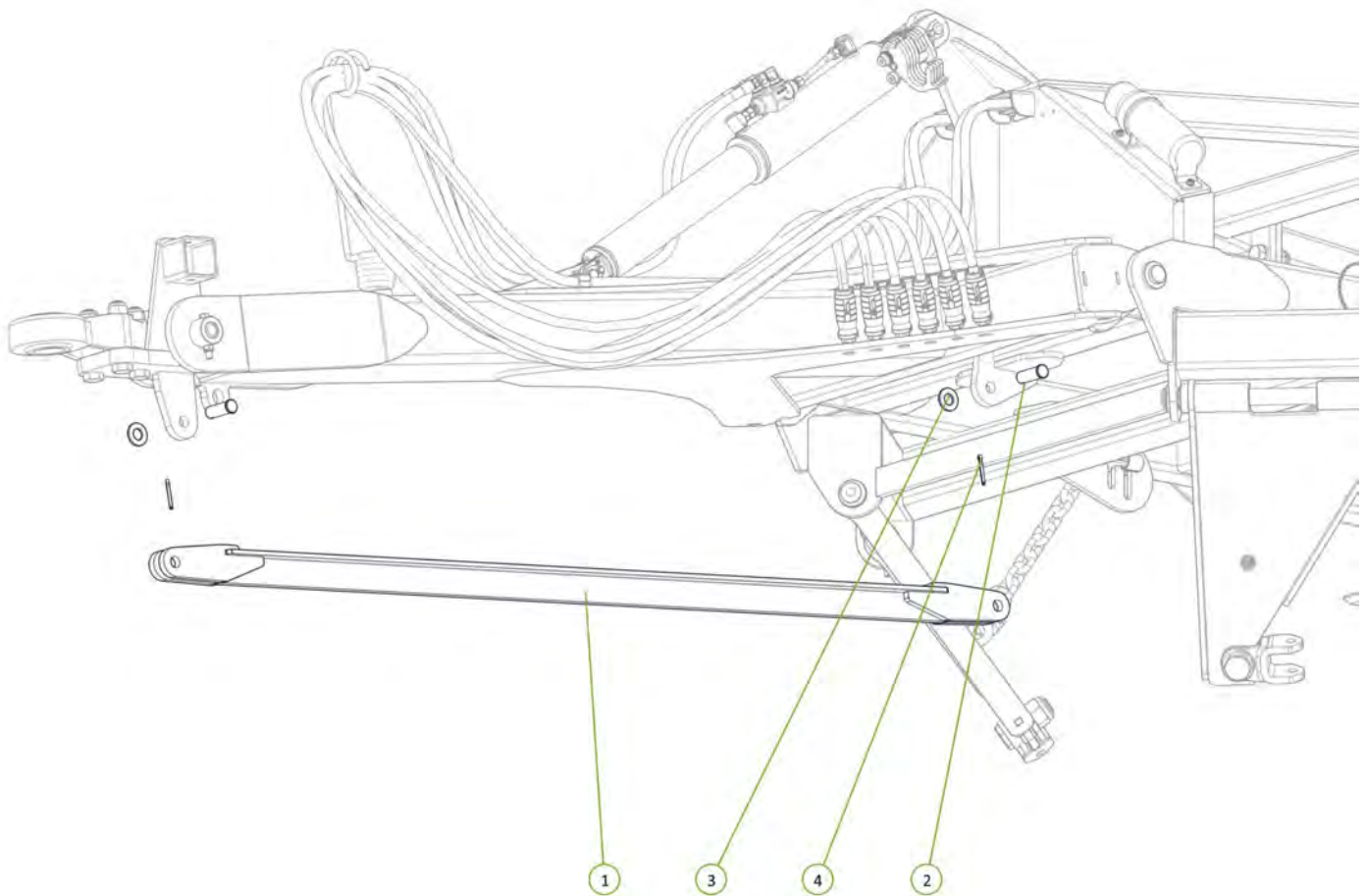

Item No.	Description	Number	Qty
1	Safety Chain Assembly	0810-16	1

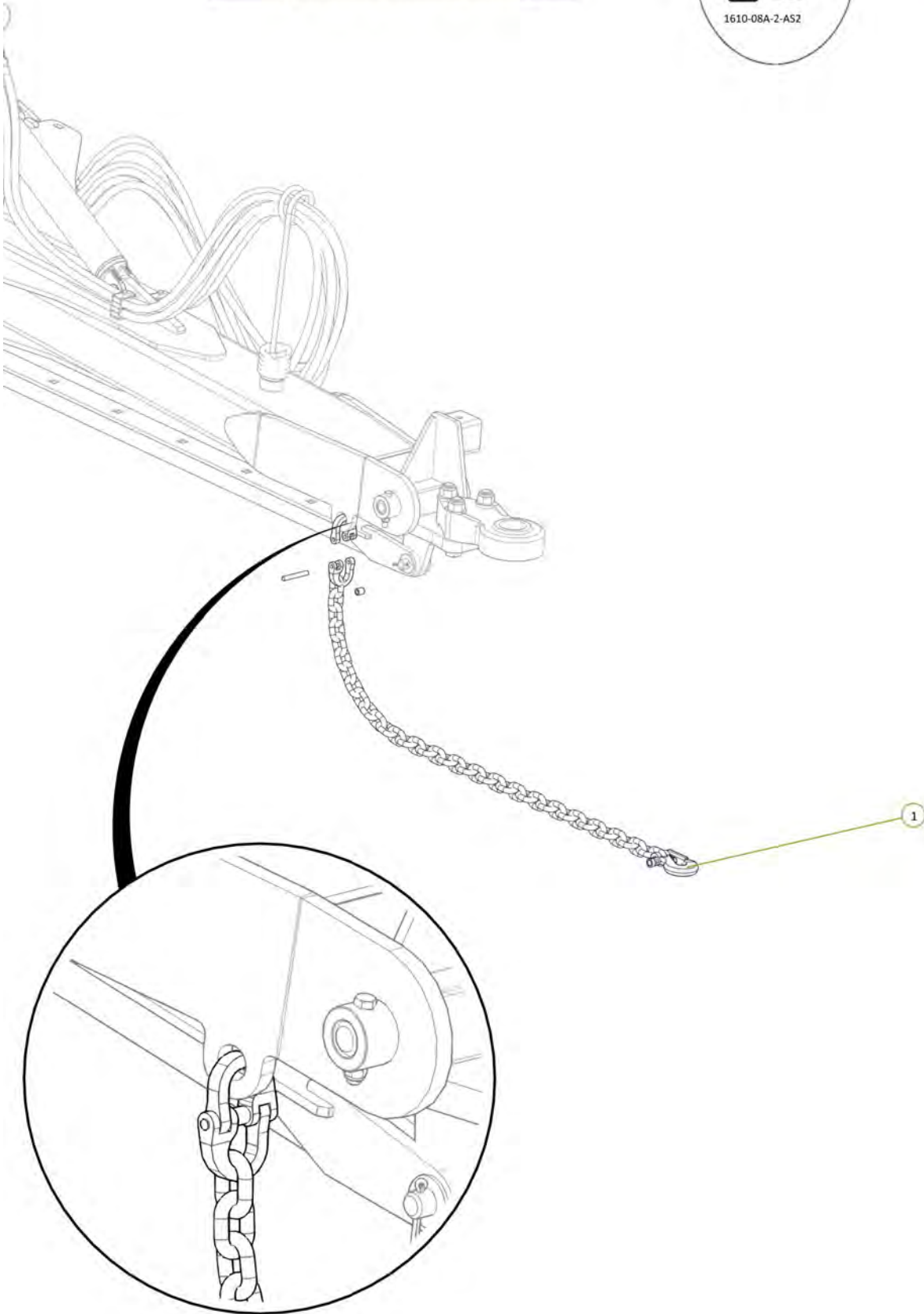
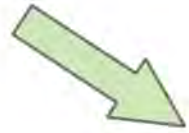

Item No.	Description	Number	Qty
1	Cylinder Safety Stop	0800-688	1
2	Square Loop Pin 5/16" x 3 1/2"	0511-PINLOOPSQ516x312	1

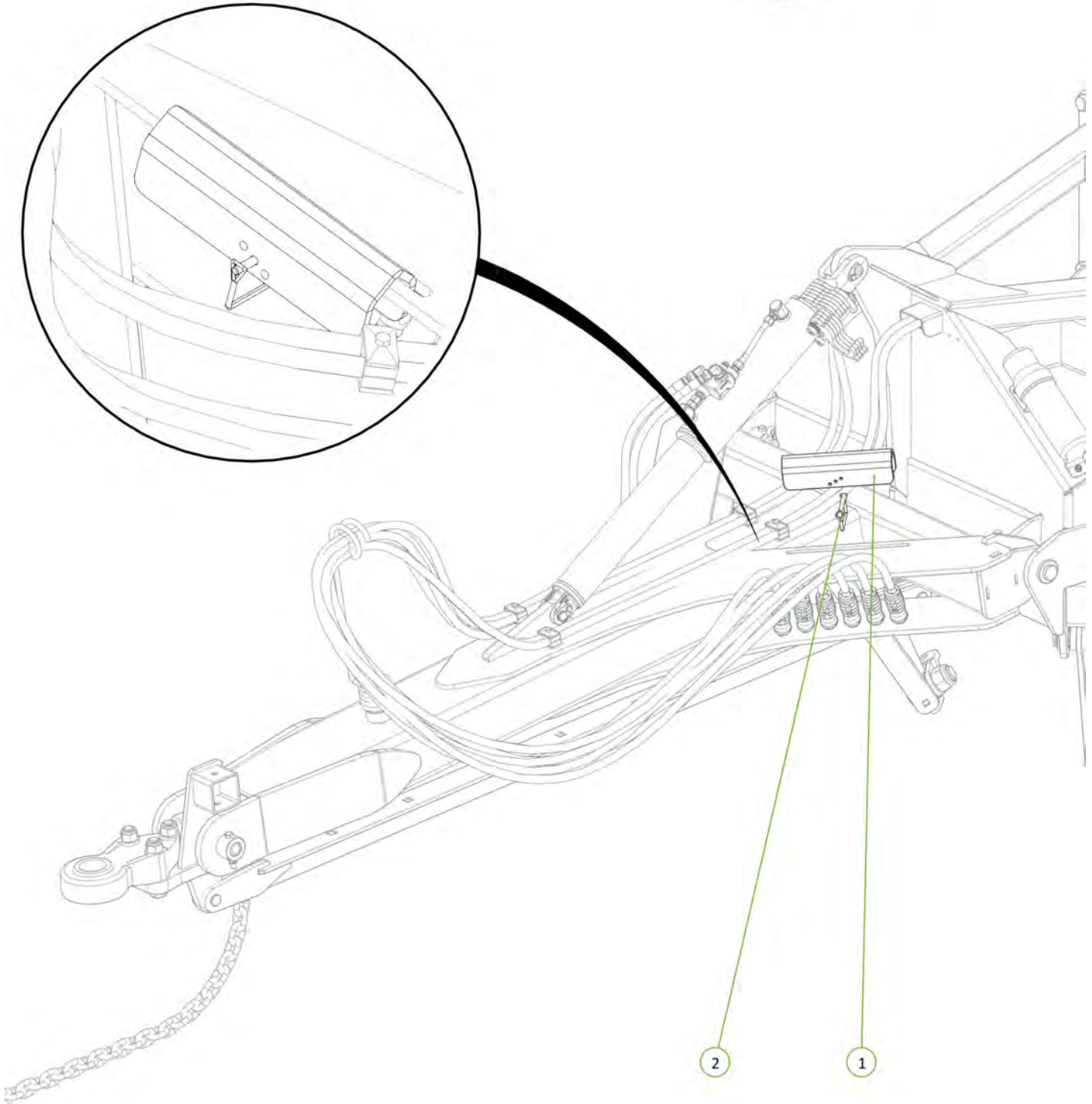

Item No.	Description	Number	Qty
1	Ratcheting Gear Wrench 1 3/4"	0802-GW1 3-4	1
2	20mm Bolt Swivel Unit	0802-PCHB55	1
3	M20 x 110 grade 10.9 ZP Short Thread Bolt	0211-20110 ST	1
4	Nyloc Nut M20	0221-NYL20	1

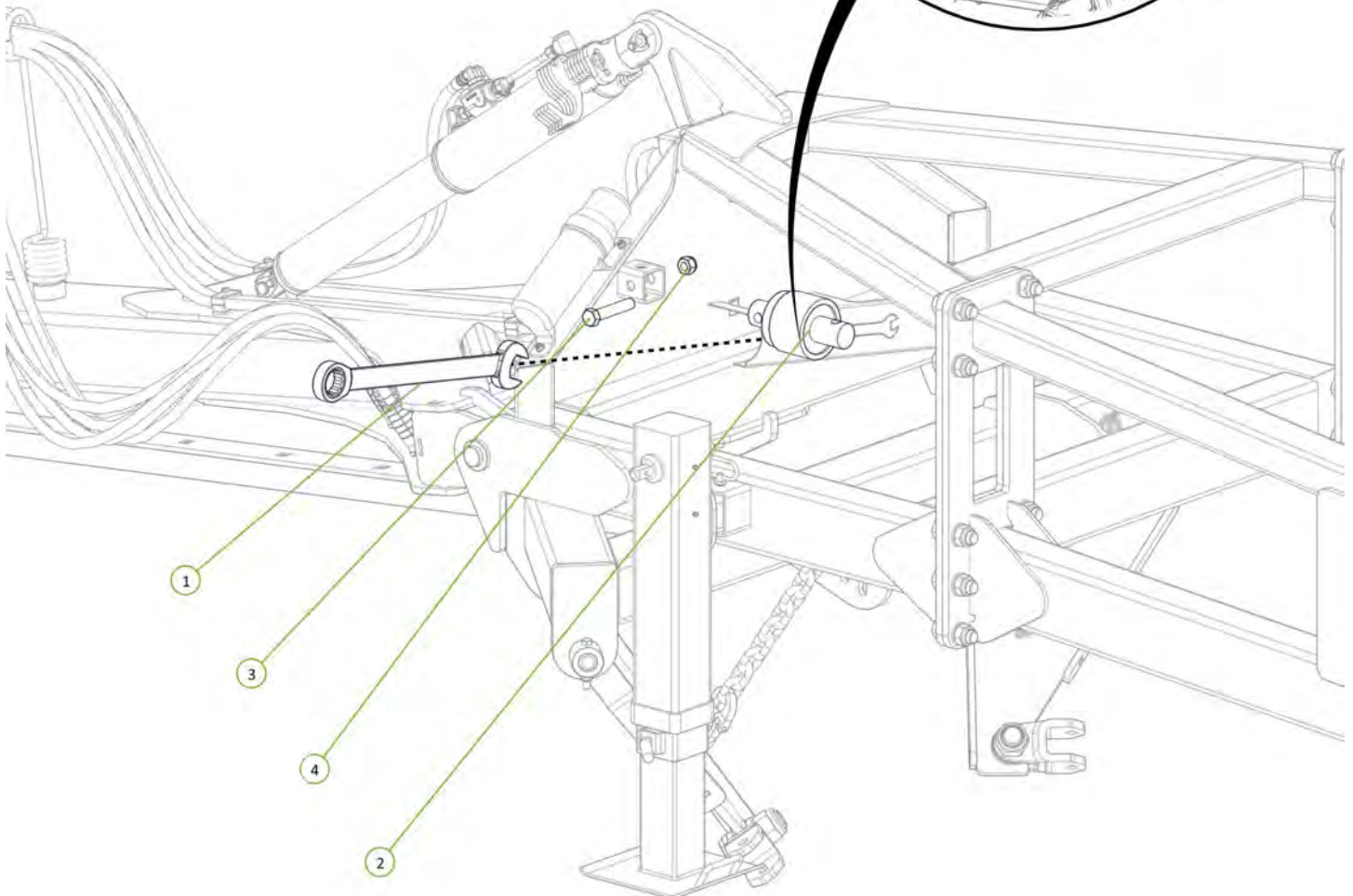
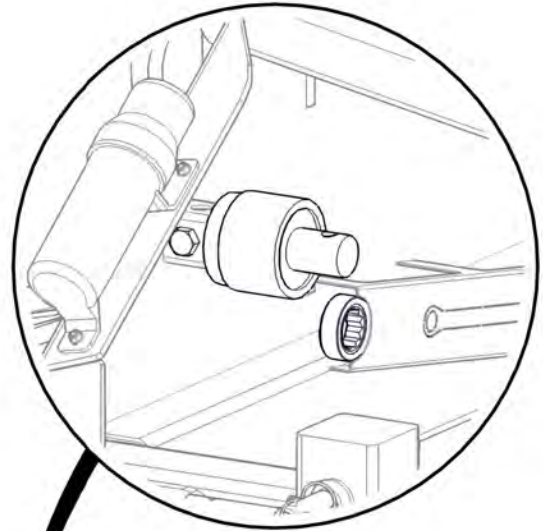
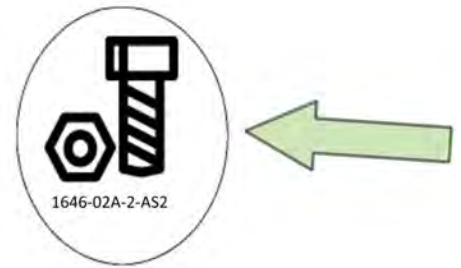

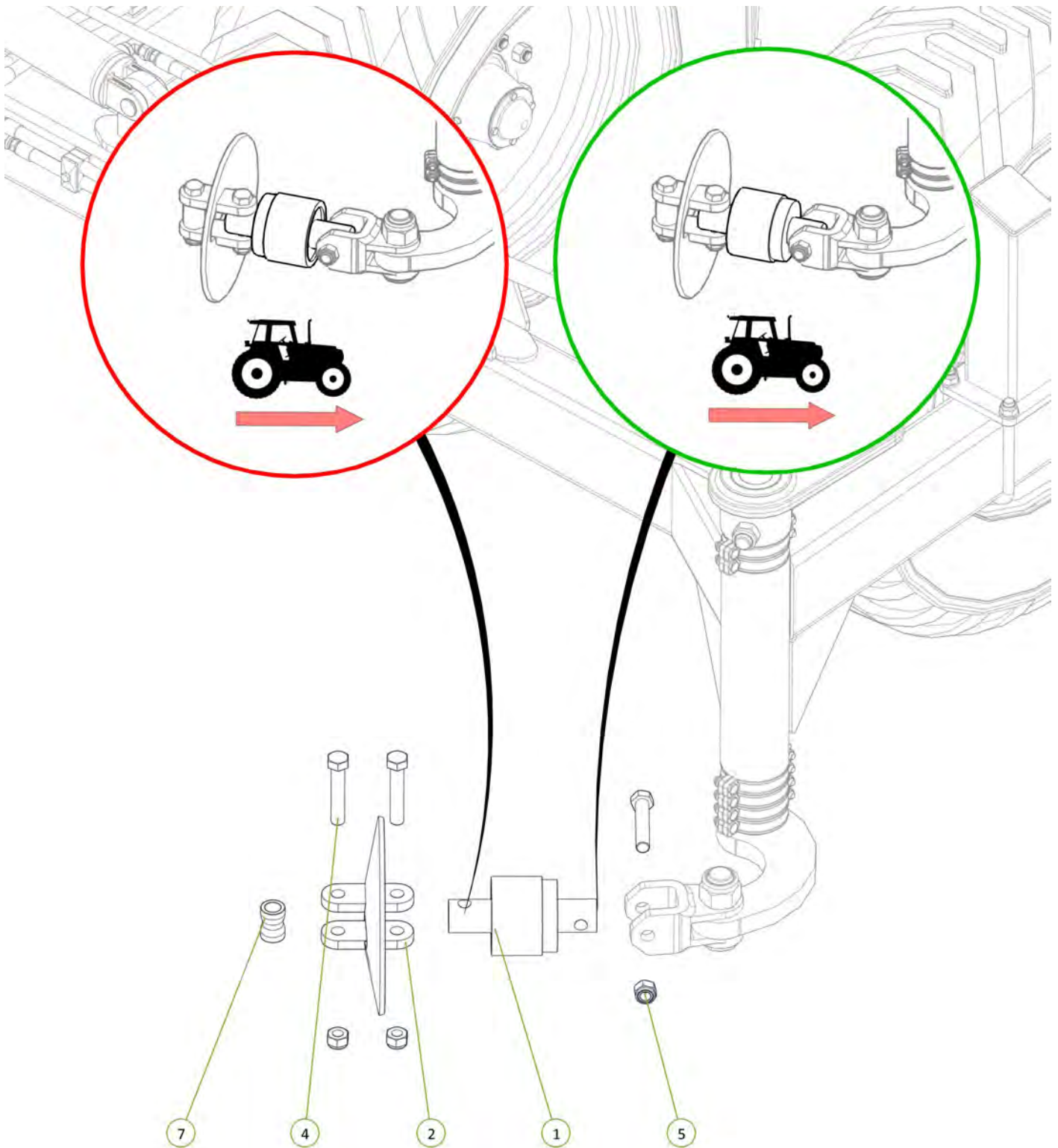

Item No.	Description	Number	Qty
1	20mm Bolt Swivel Unit	0802-PCHB55	1
2	Disc Chain Tie Plate Link 20mm	0802-DCTP-20	1
4	M20 x 110 grade 10.9 ZP Short Thread Bolt	0211-20110 ST	3
5	Nyloc Nut M20	0221-NYL20	3
7	Disc Chain Spacer	0801-253755	1



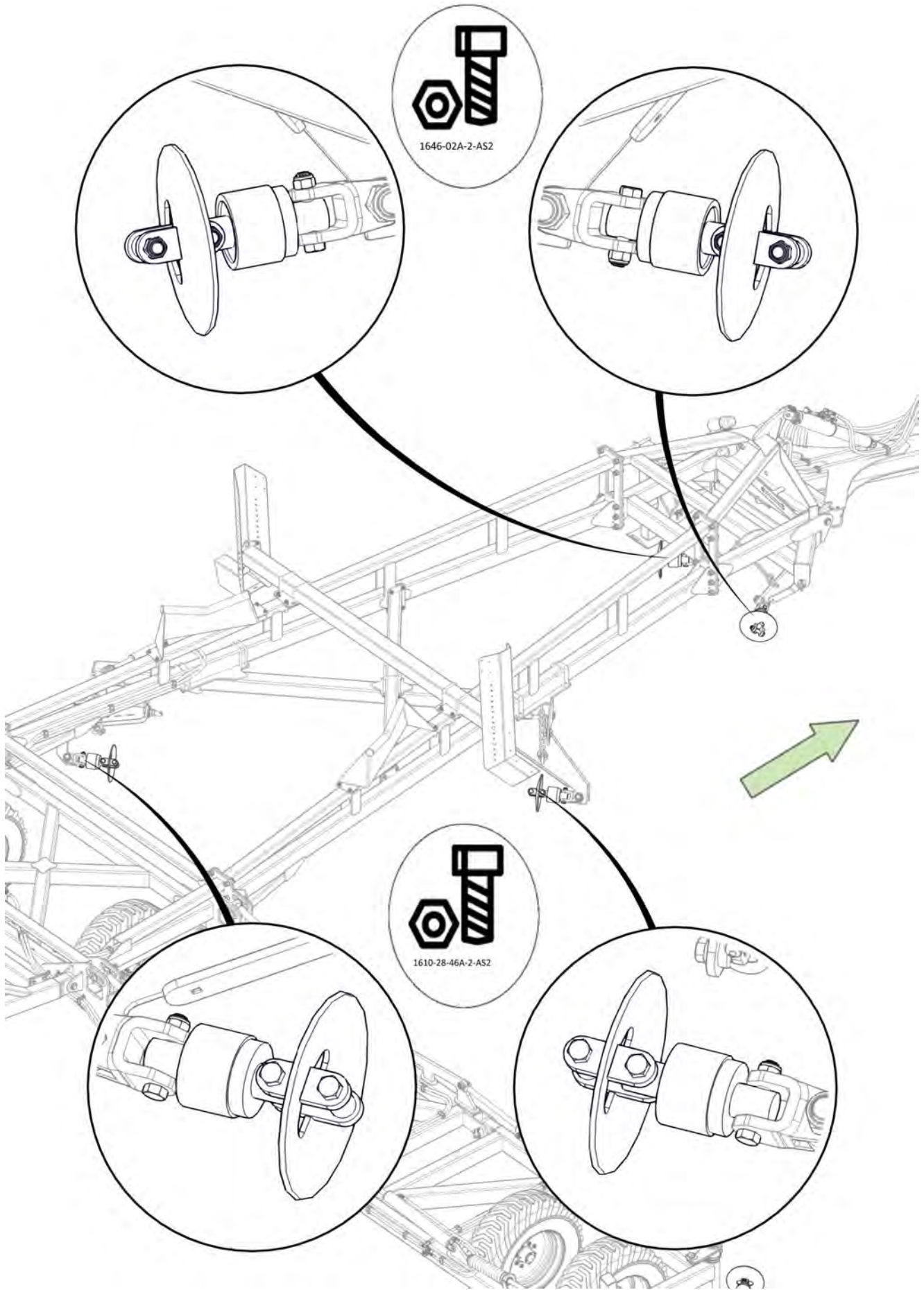

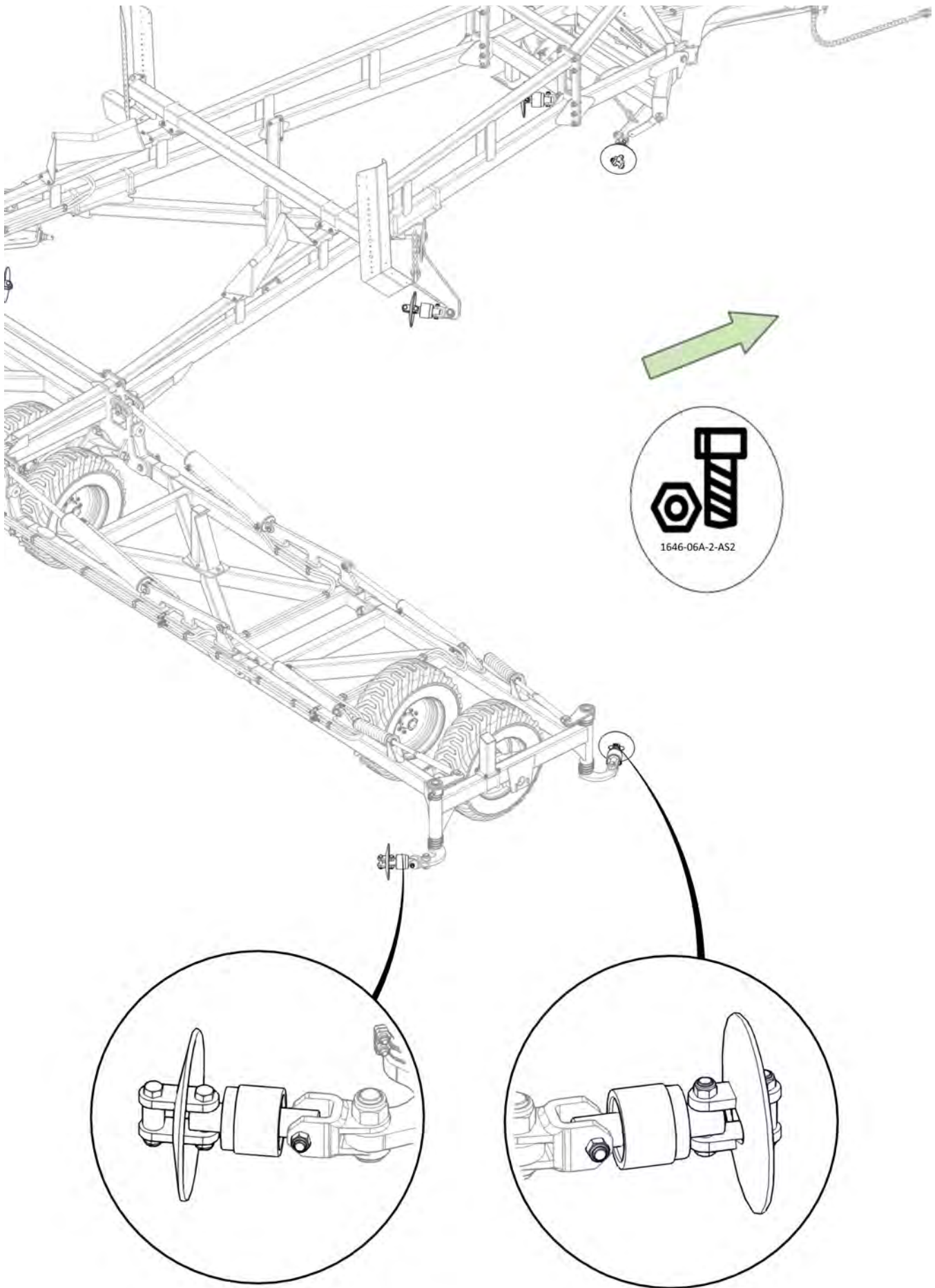

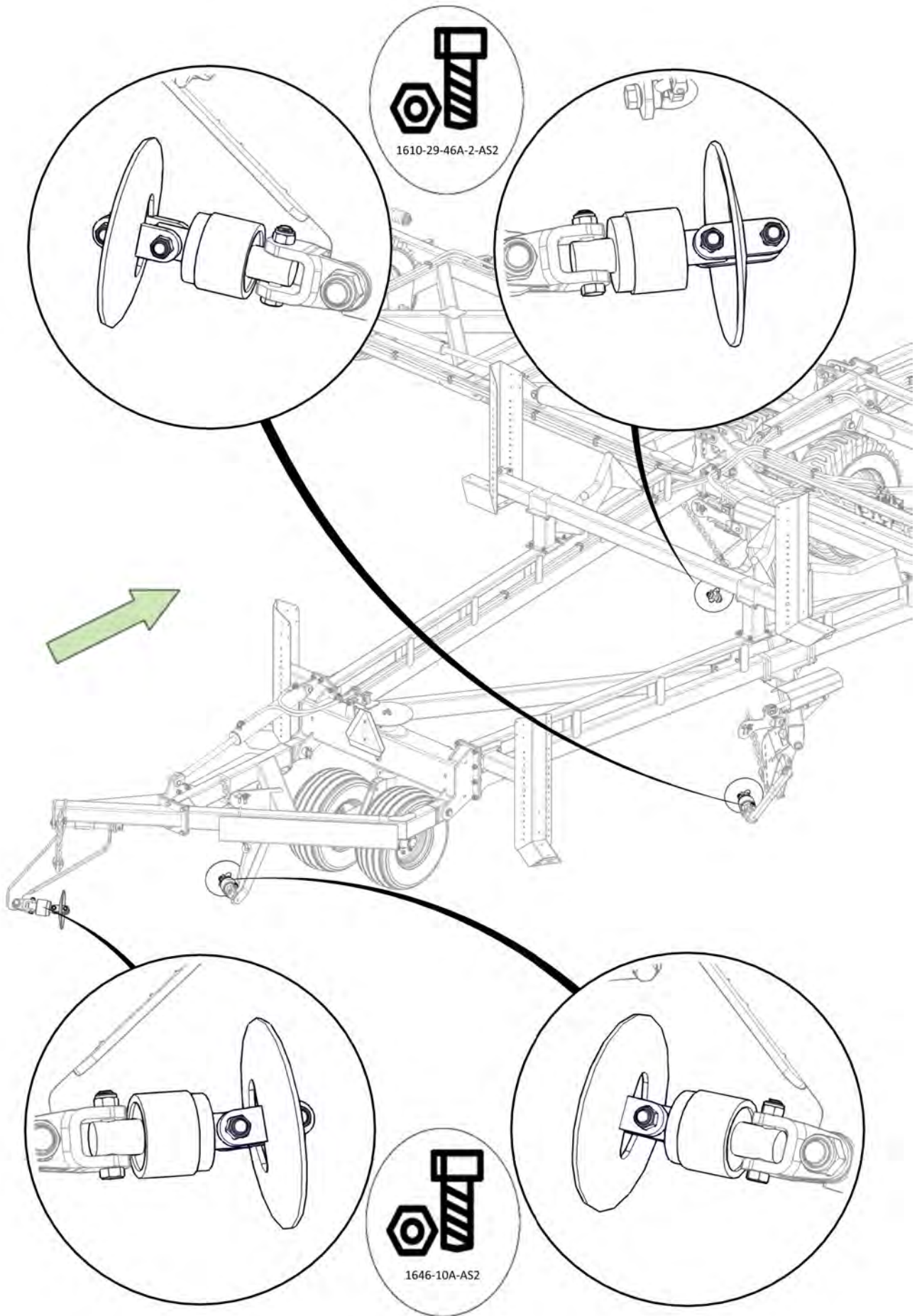

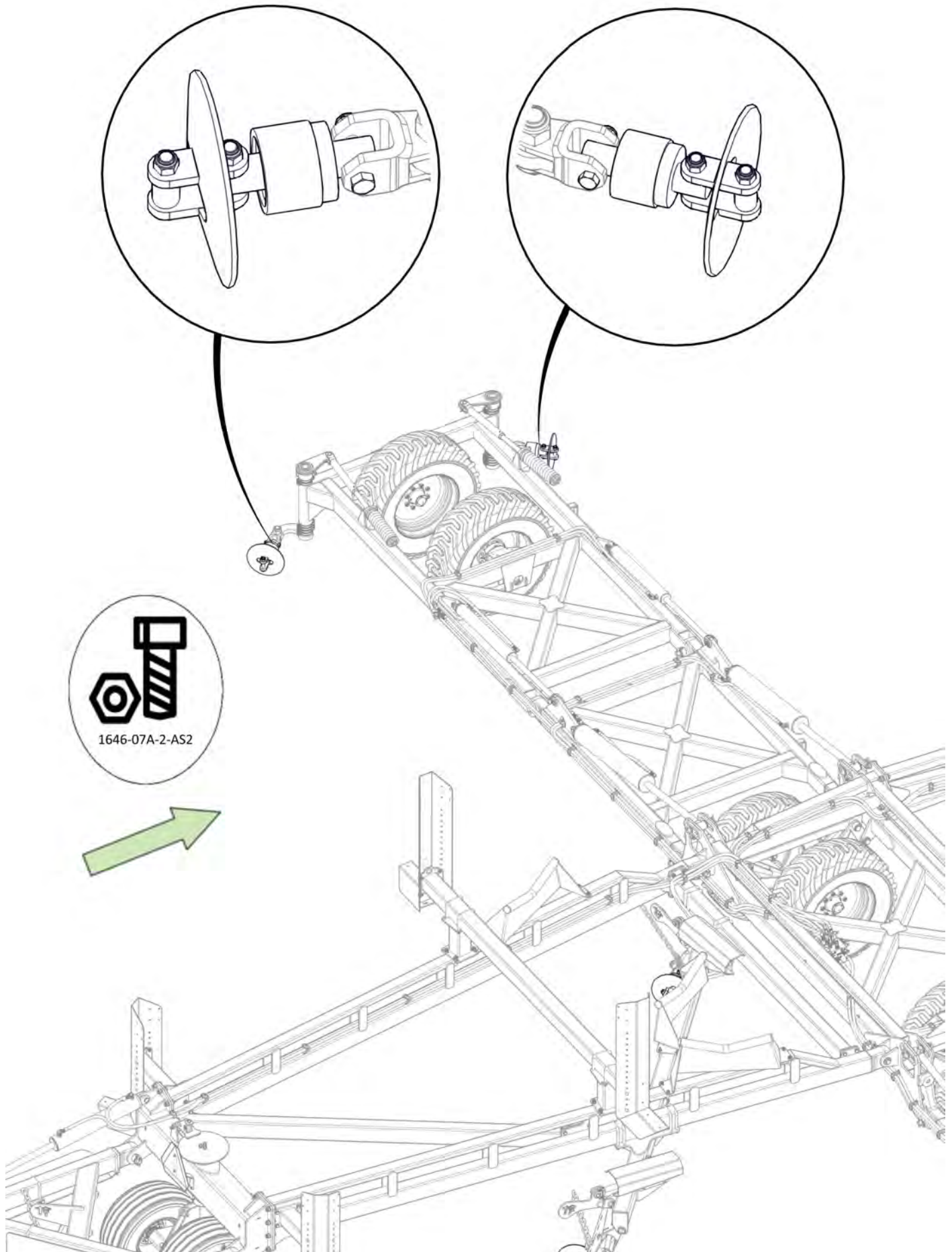

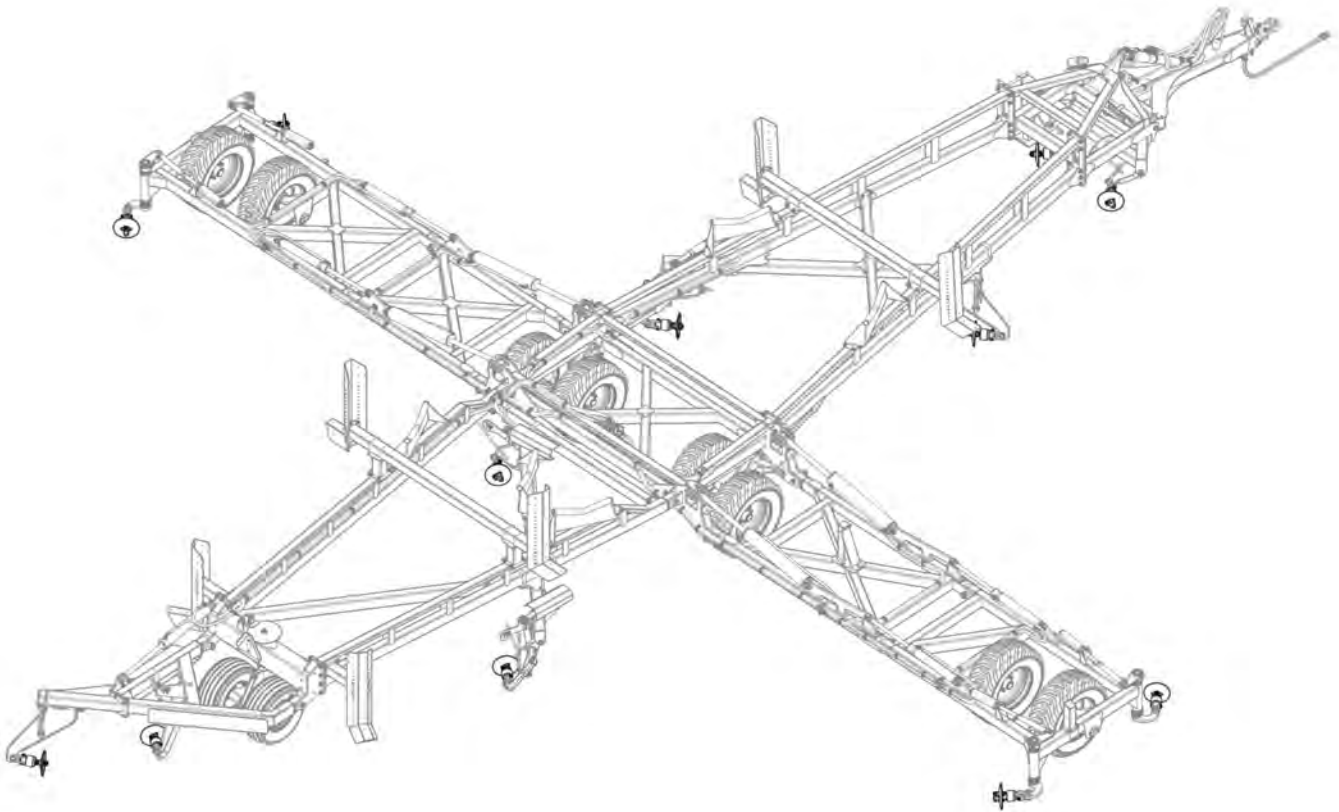

Ensure bearings are correctly orientated with seals facing the rear of their machine

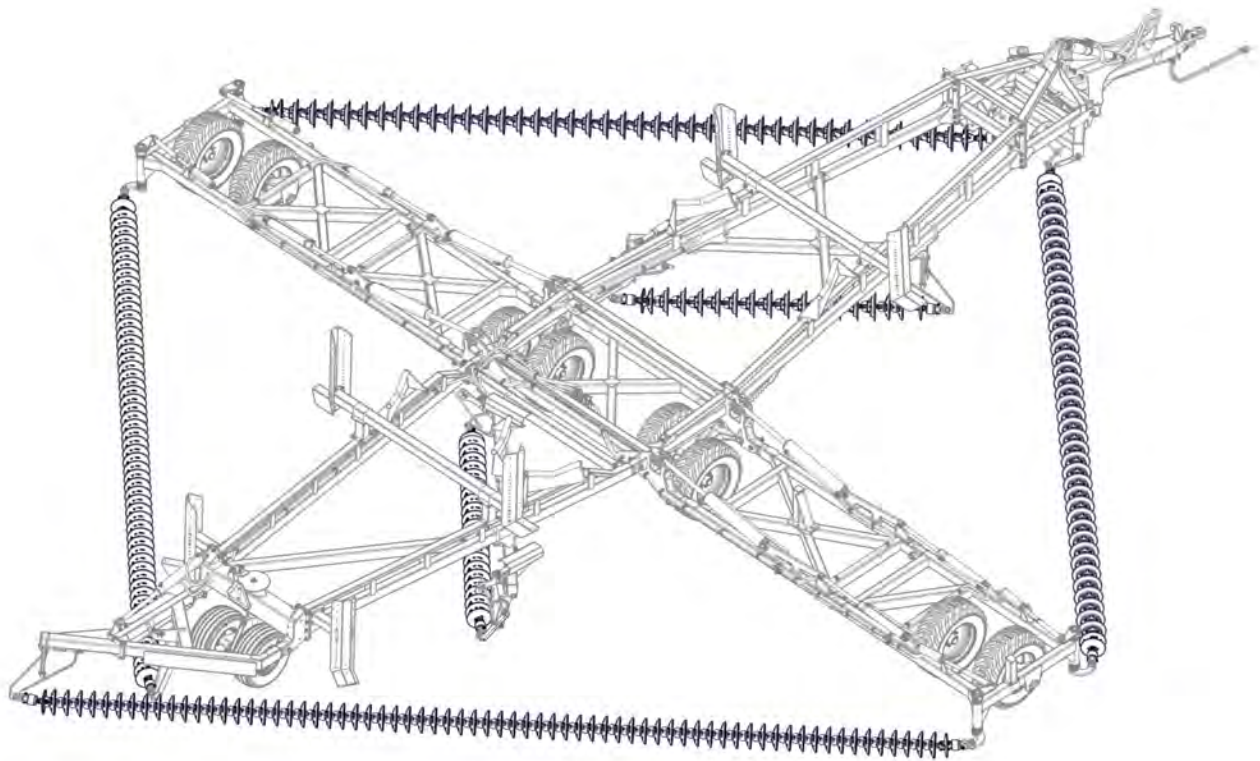



Section 3 - Decal Application

- 1. CLEAN**
Wipe application surface and allow to fully dry. Ensure the area is free from dirt and contaminants.
- 2. PEEL BACKING**
Carefully peel away paper backing.
- 3. ALIGN AND PRESS**
Align the decal and carefully place it on surface.
- 4. SMOOTH**
Use a squeegee to smooth design over surface, from top to bottom and to push out all remaining air. Ensure full coverage with no bubbles.

For the Kelly Harrow 3009 Decal (0801-SKDH3009), follow this instructions below:

- 1. CLEAN**
Wipe application surface and allow to fully dry. Ensure the area is free from dirt, and contaminants.
- 2. PEEL BACKING**
Carefully peel away paper backing, ensuring vinyl sticks entirely to tape.
- 3. ALIGN AND PRESS**
Align the decal and carefully place it on surface.
- 4. SMOOTH**
Use a squeegee to smooth design over surface, from top to bottom and to push out all remaining air. Ensure full coverage with no bubbles.
- 5. REMOVE TRANSFER TAPE**
Carefully peel away the transfer tape, beginning at the corner until completely removed. Finally, allow decal to cure for 24 hours before washing.

For the Fold/Unfold Decal (0801-S1), follow this instructions below:

- 1. CLEAN**
Wipe application surface and allow to fully dry. Ensure the area is free from dirt and contaminants.
- 2. APPLY SOLUTION**
Using detergent wet the surface where you'll be applying the decal so you can slide it around.
- 3. PEEL BACKING**
Carefully peel away paper backing.
- 4. ALIGN AND PRESS**
Align the decal and carefully place it on surface.
- 5. SMOOTH**
Use a squeegee to smooth design over surface, from center to corners and to push out all remaining air. Ensure full coverage with no bubbles.

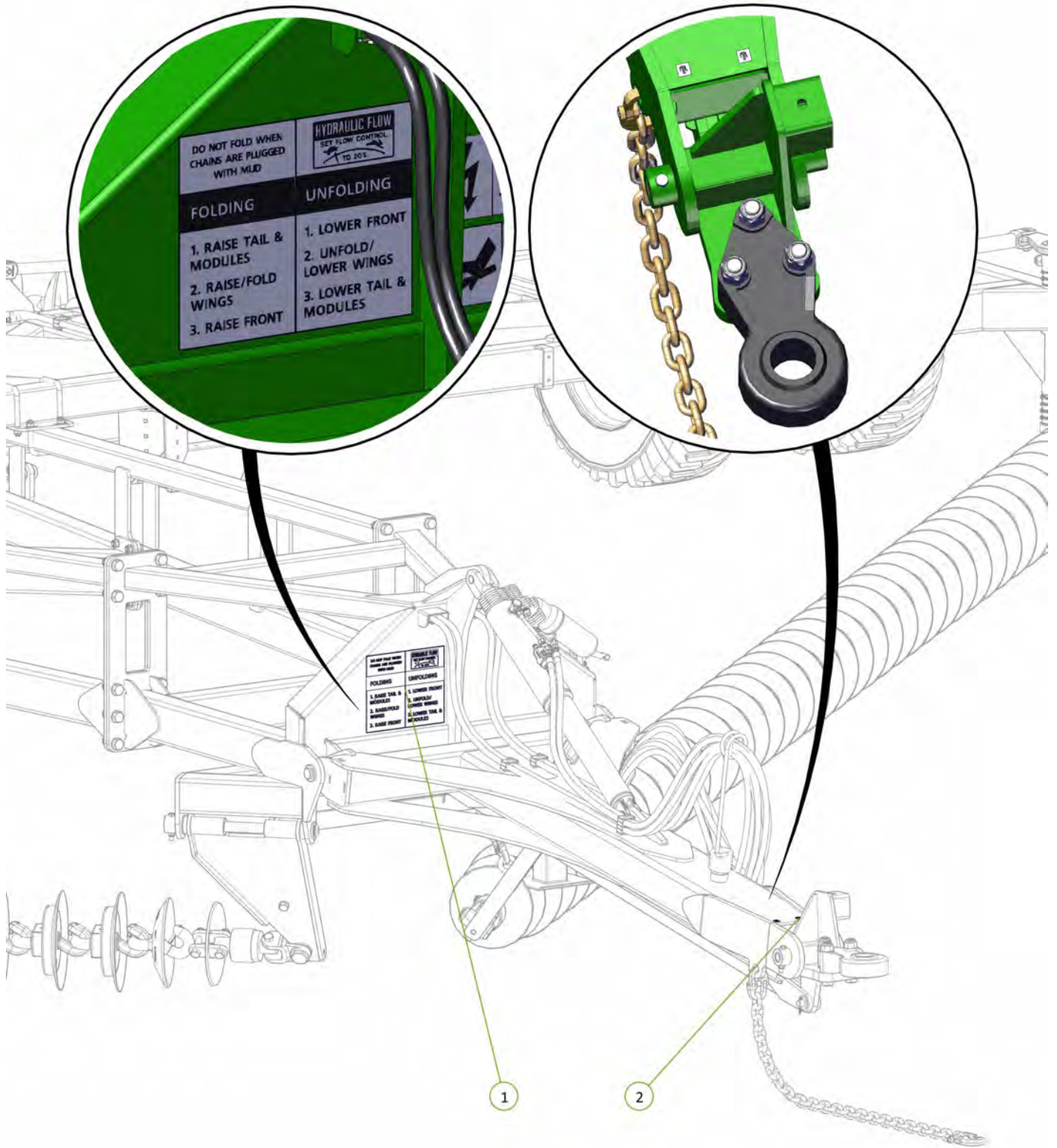

Item No.	Description	Number	Qty
1	Fold-Unfold Decal 340 x 280mm	0801-S18	1
2	Grease Decal	0801-S10	2



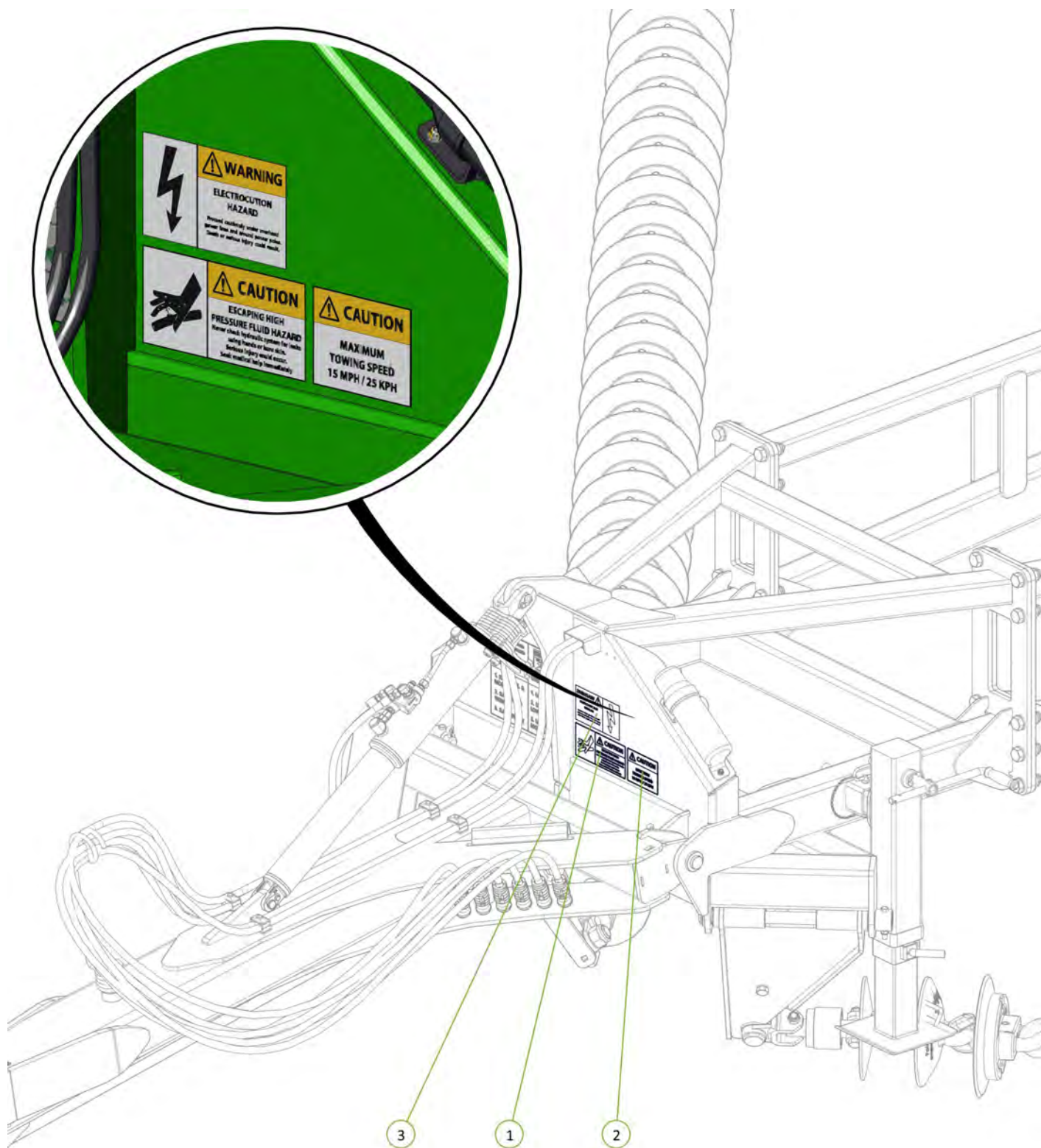

Item No.	Description	Number	Qty
1	Hydraulic Pressure Caution Decal	0801-S4	1
2	Towing Speed Decal	0801-S5	1
3	Electrocution Hazard Decal	0801-S6	1



Item No.	Description	Number	Qty
1	Kelly Tillage Data Plate	0801-SKTDP	1
2	Universal Patent Decal	0801-S26	1

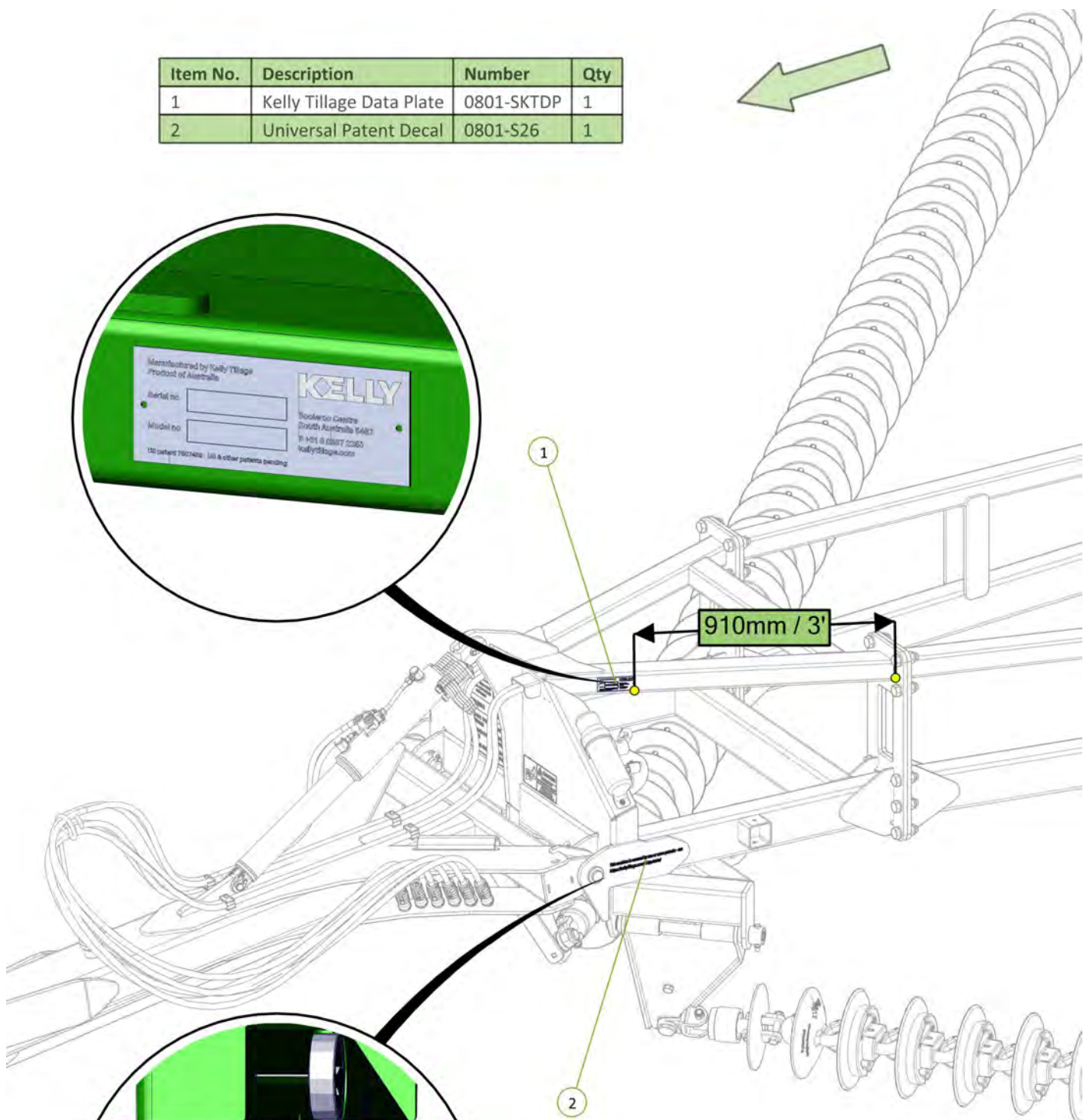

Item No.	Description	Number	Qty
1	Kelly Tillage Decal	0801-S24	2

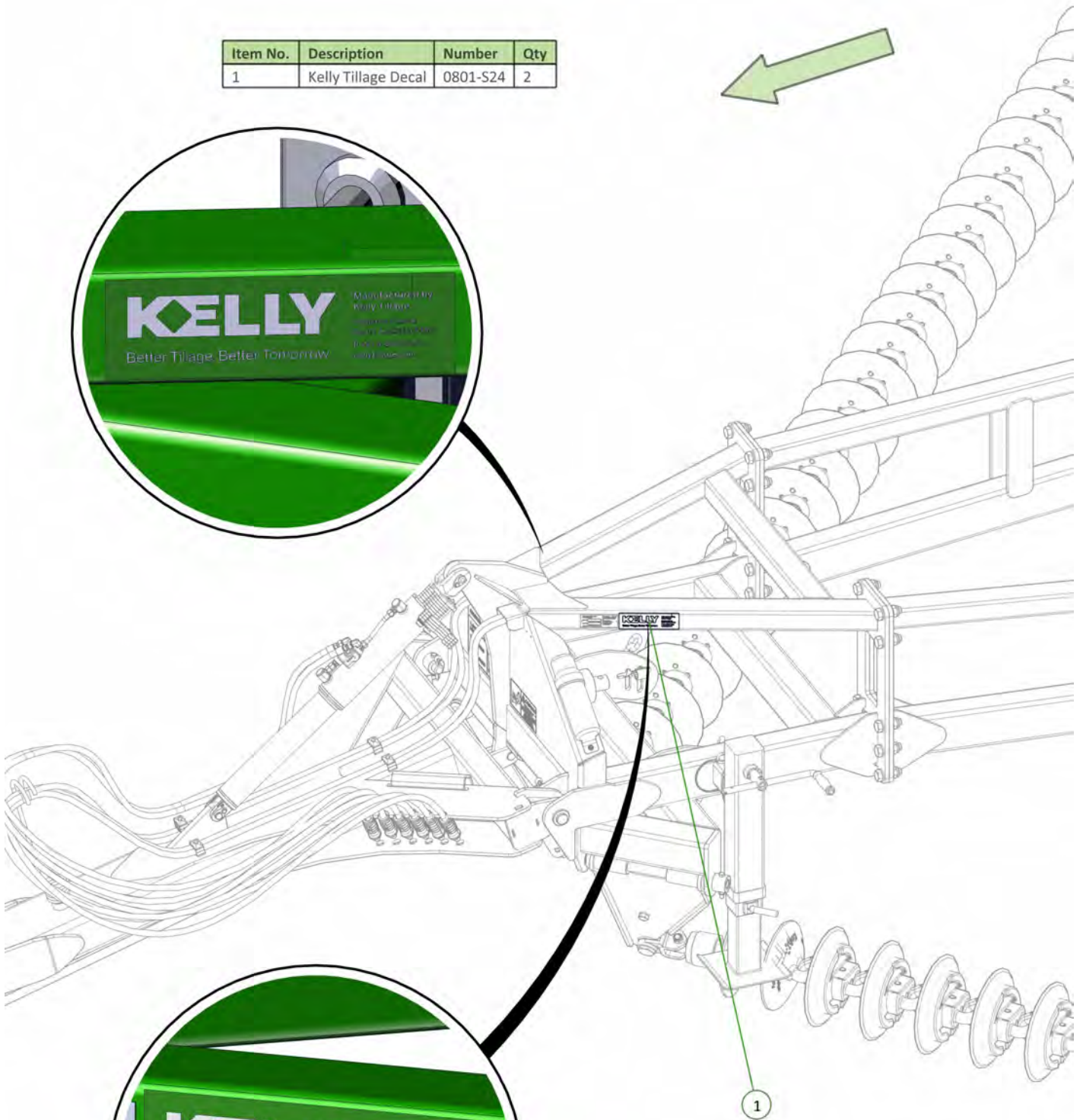

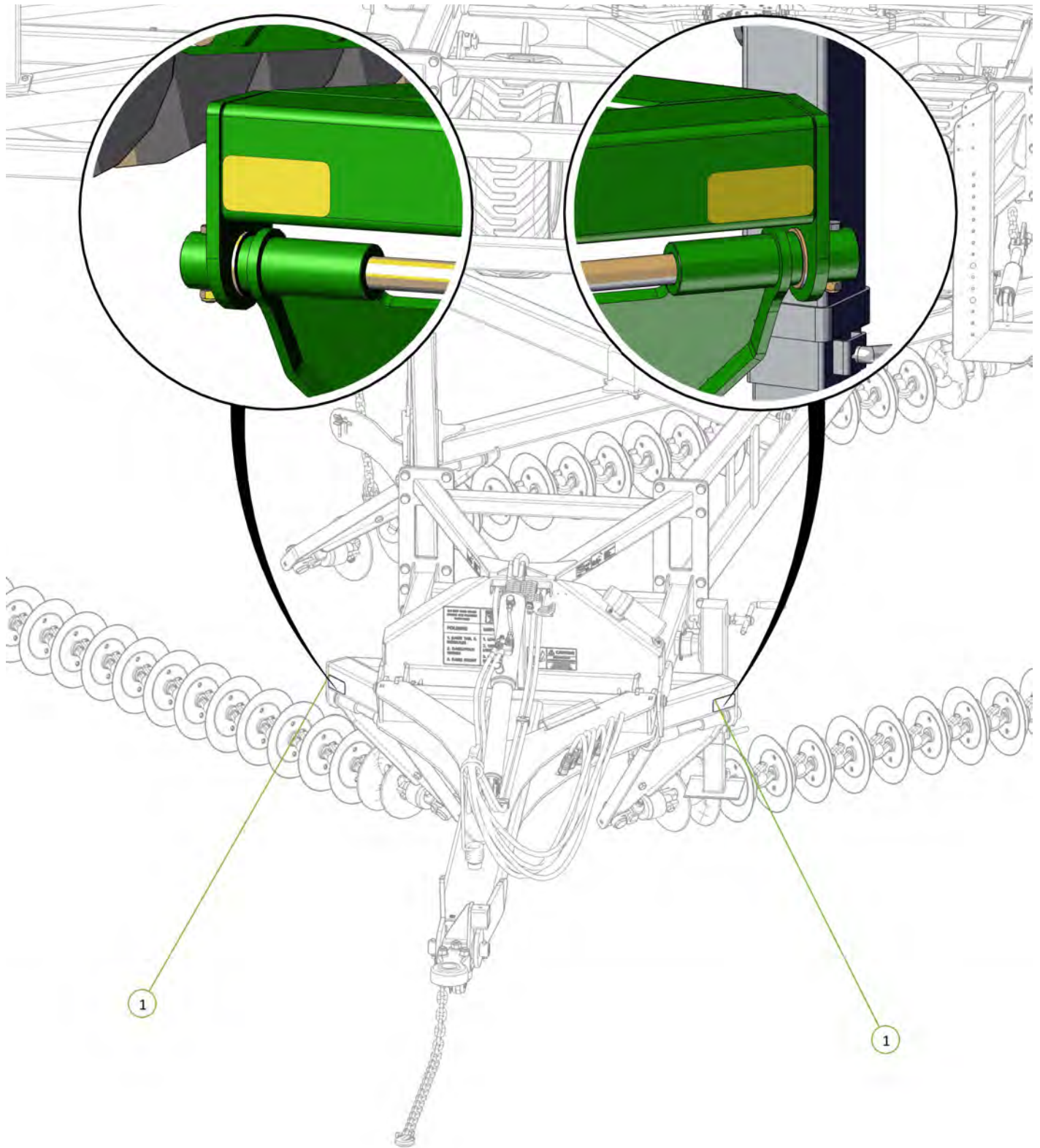

Item No.	Description	Number	Qty
1	Yellow Reflective Decal	0801-SYRF	2



Item No.	Description	Number	Qty
1	Kelly Tillage 4614 Decal	0801-SKT4614	2

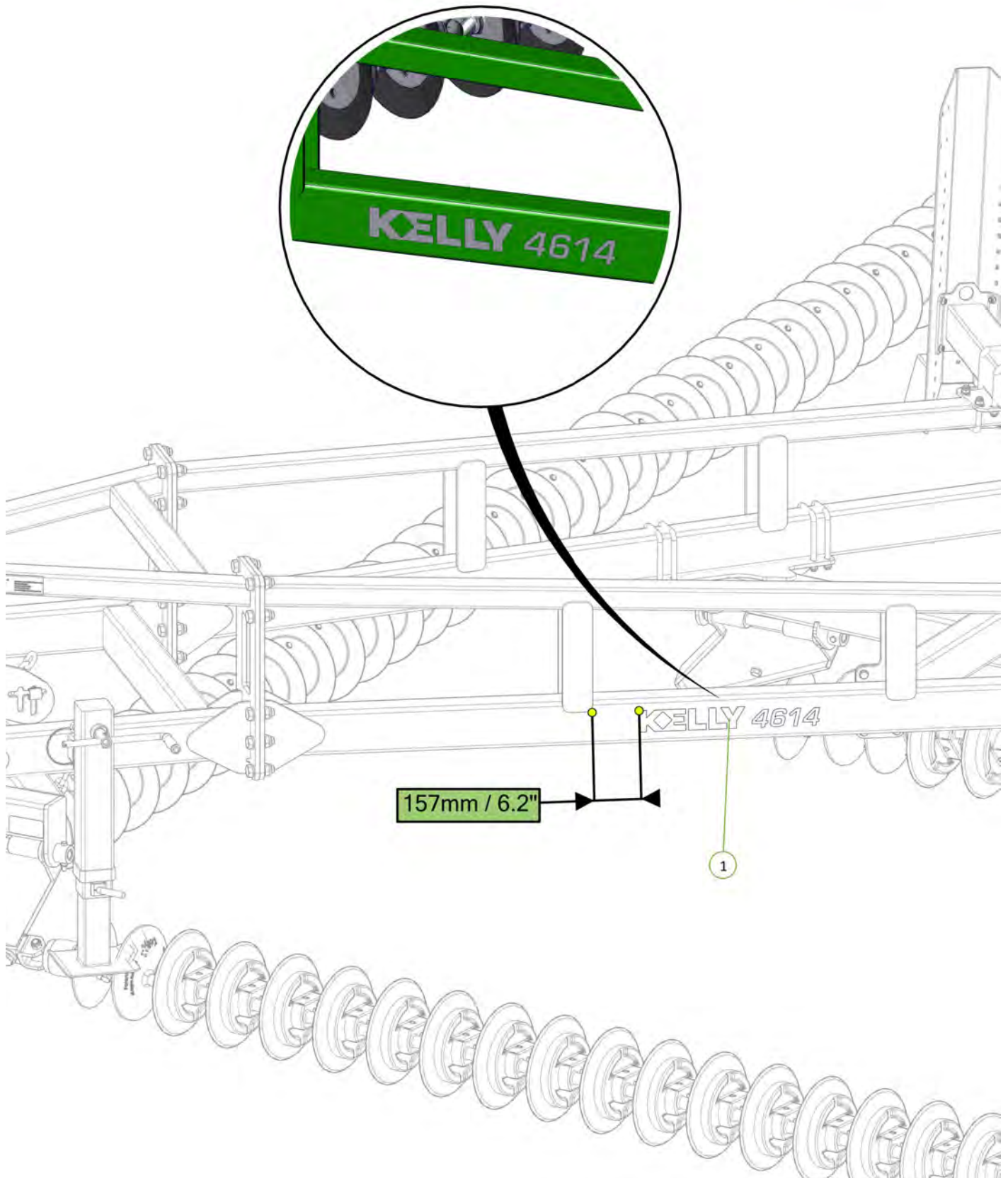

Item No.	Description	Number	Qty
1	Kelly Tillage 4614 Decal	0801-SKT4614	1
2	Chain Tension 330mm Decal	0801-S15	1

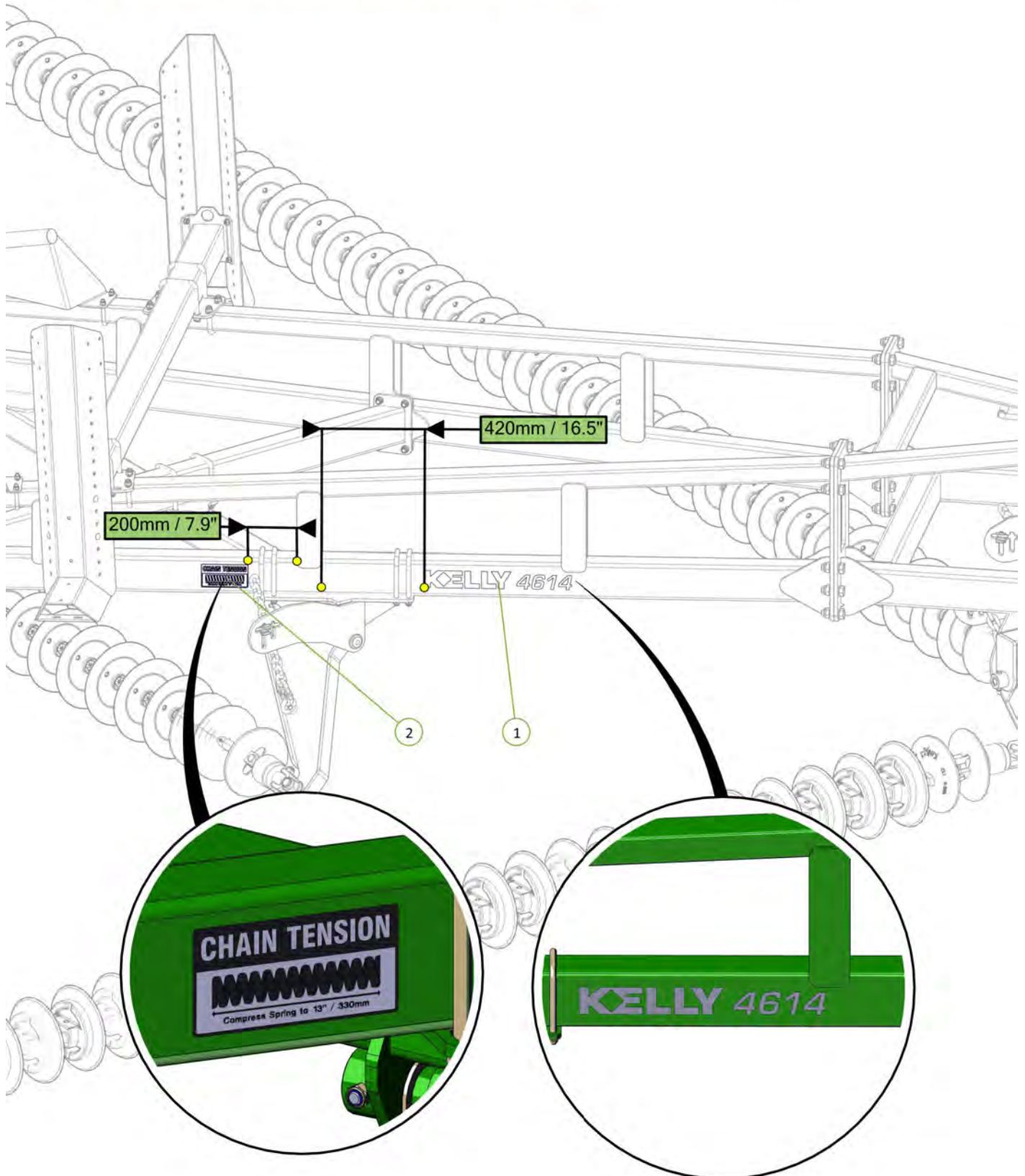

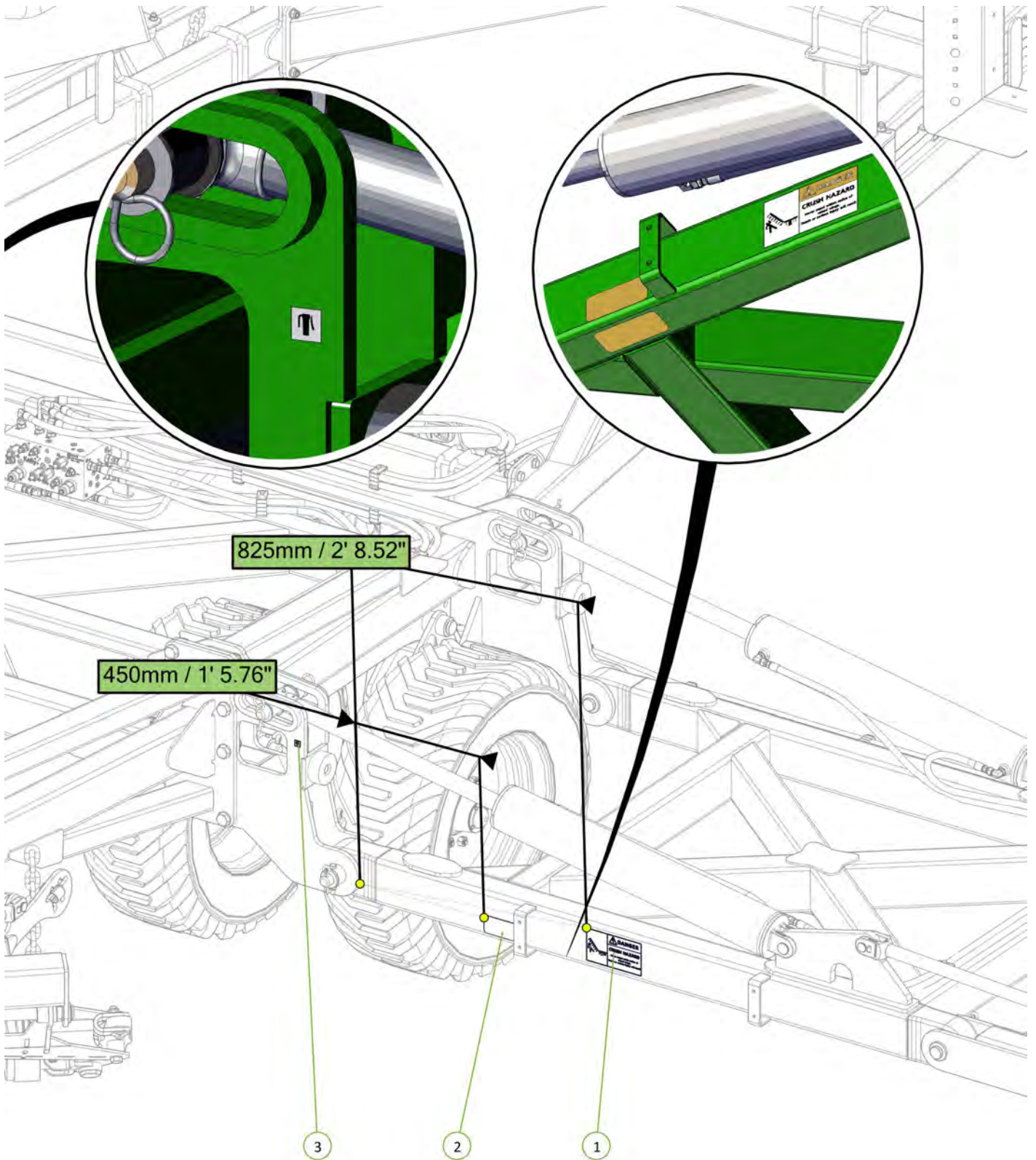

Item No.	Description	Number	Qty
1	Danger Crush Hazard Decal	0801-S3	1
2	Yellow Reflective Decal	0801-SYRF	2
3	Grease Decal	0801-S10	1



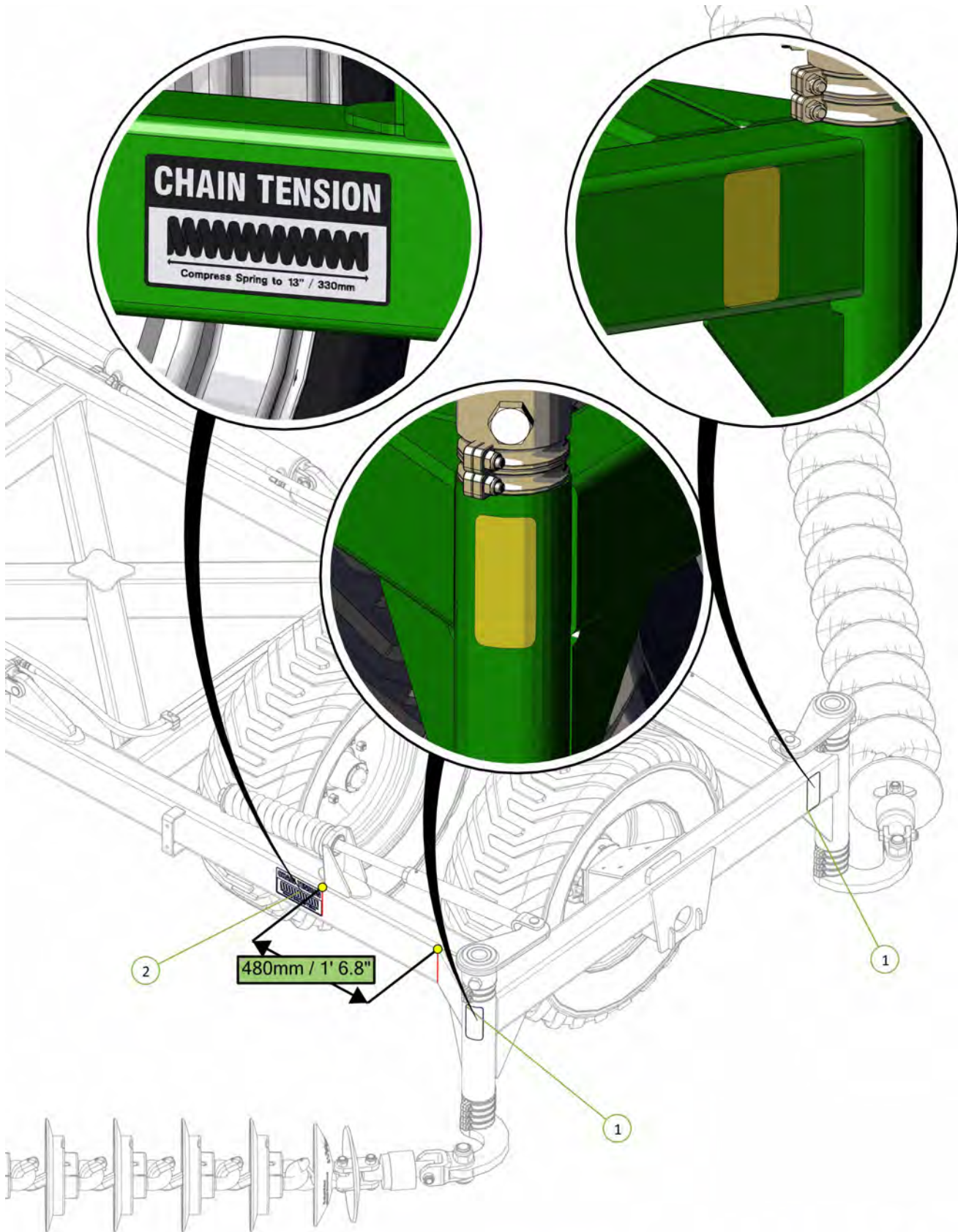

Item No.	Description	Number	Qty
1	Yellow Reflective Decal	0801-SYRF	2
2	Chain Tension 330mm Decal	0801-S15	1



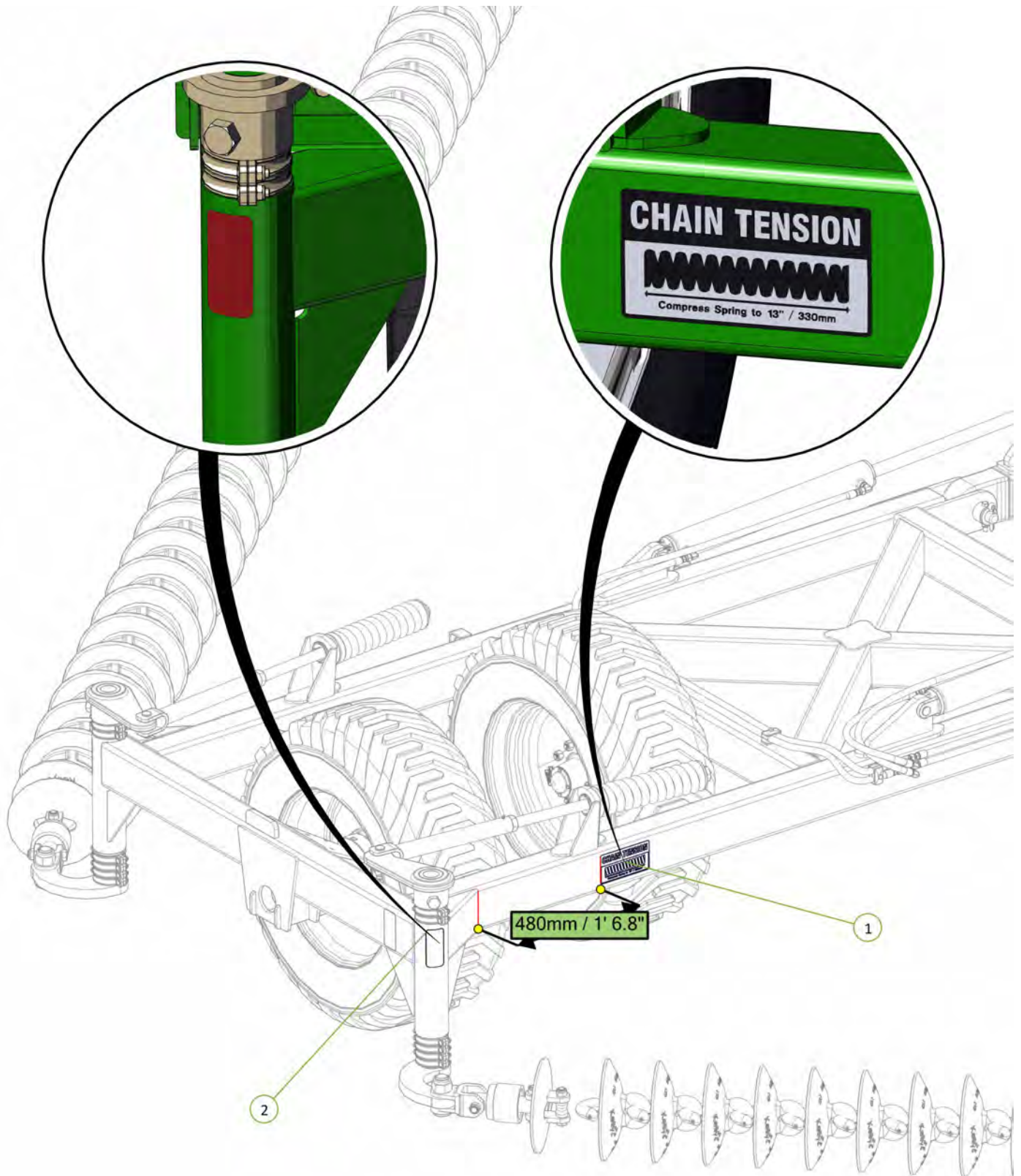

Item No.	Description	Number	Qty
1	Chain Tension 330mm Decal	0801-S15	1
2	Red Reflective Decal	0801-SRRF	1



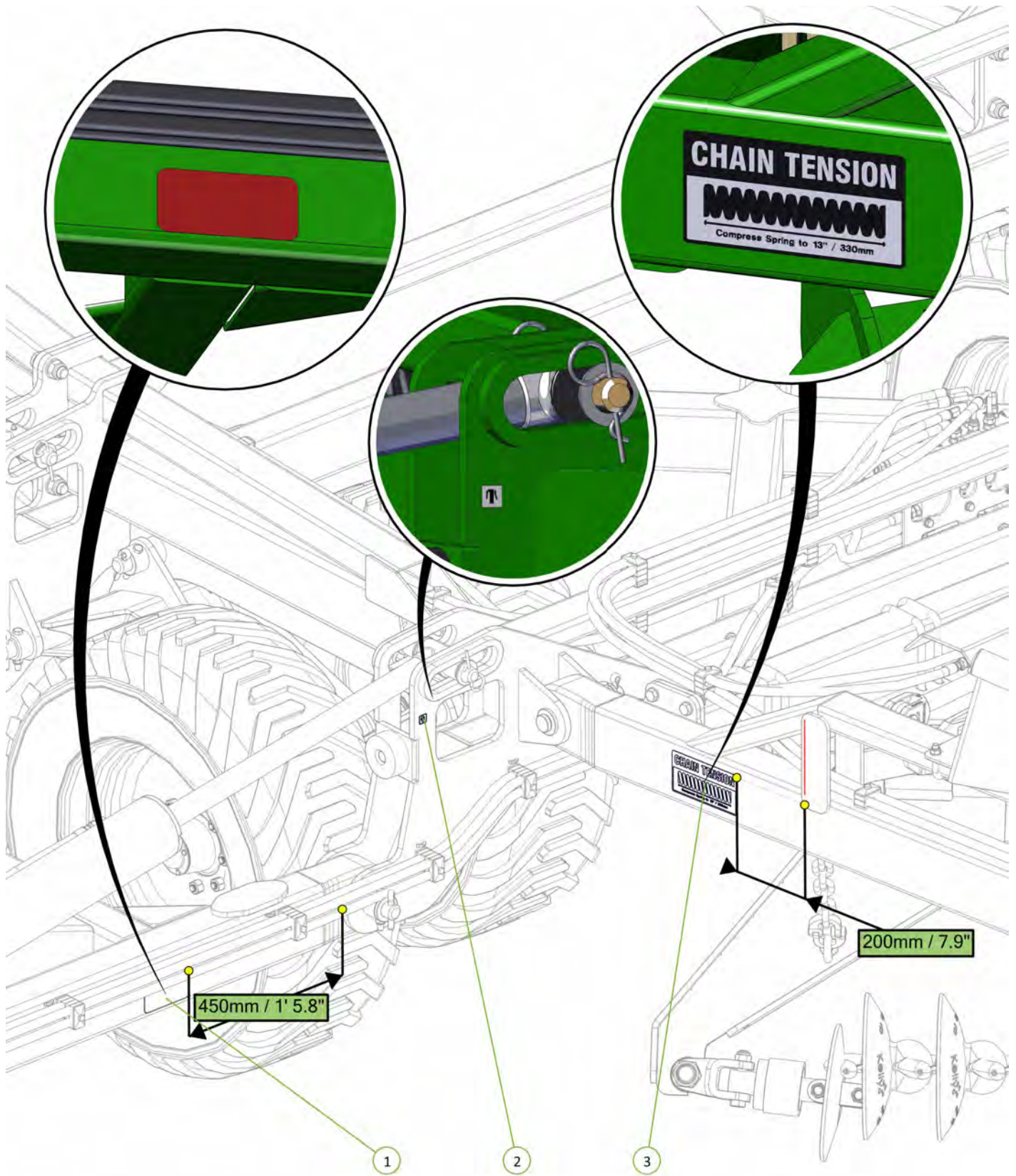

Item No.	Description	Number	Qty
1	Red Reflective Decal	0801-SRRF	1
2	Grease Decal	0801-S10	1
3	Chain Tension 330mm Decal	0801-S15	1



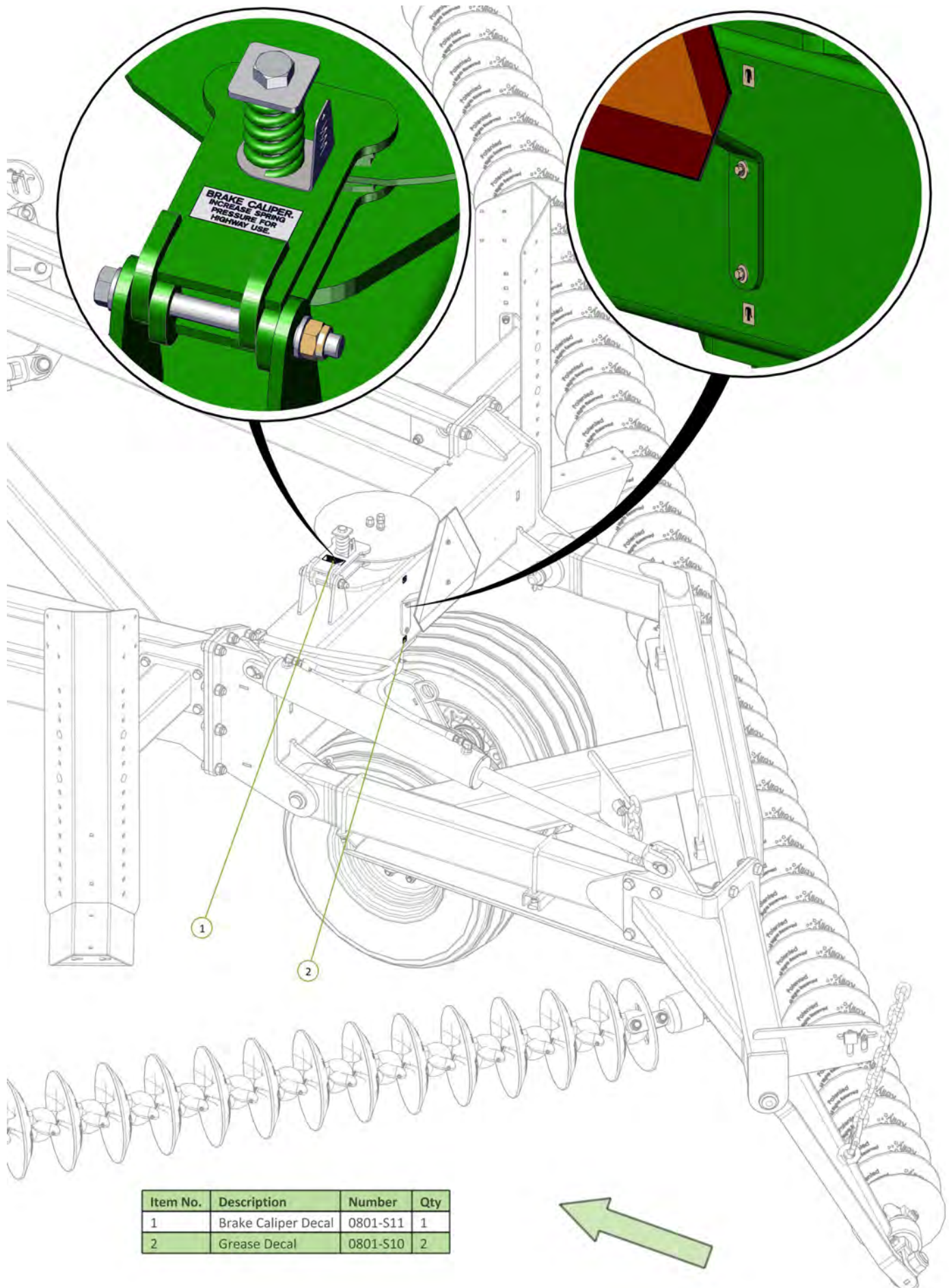

Item No.	Description	Number	Qty
1	Yellow Reflective Decal	0801-SYRF	1

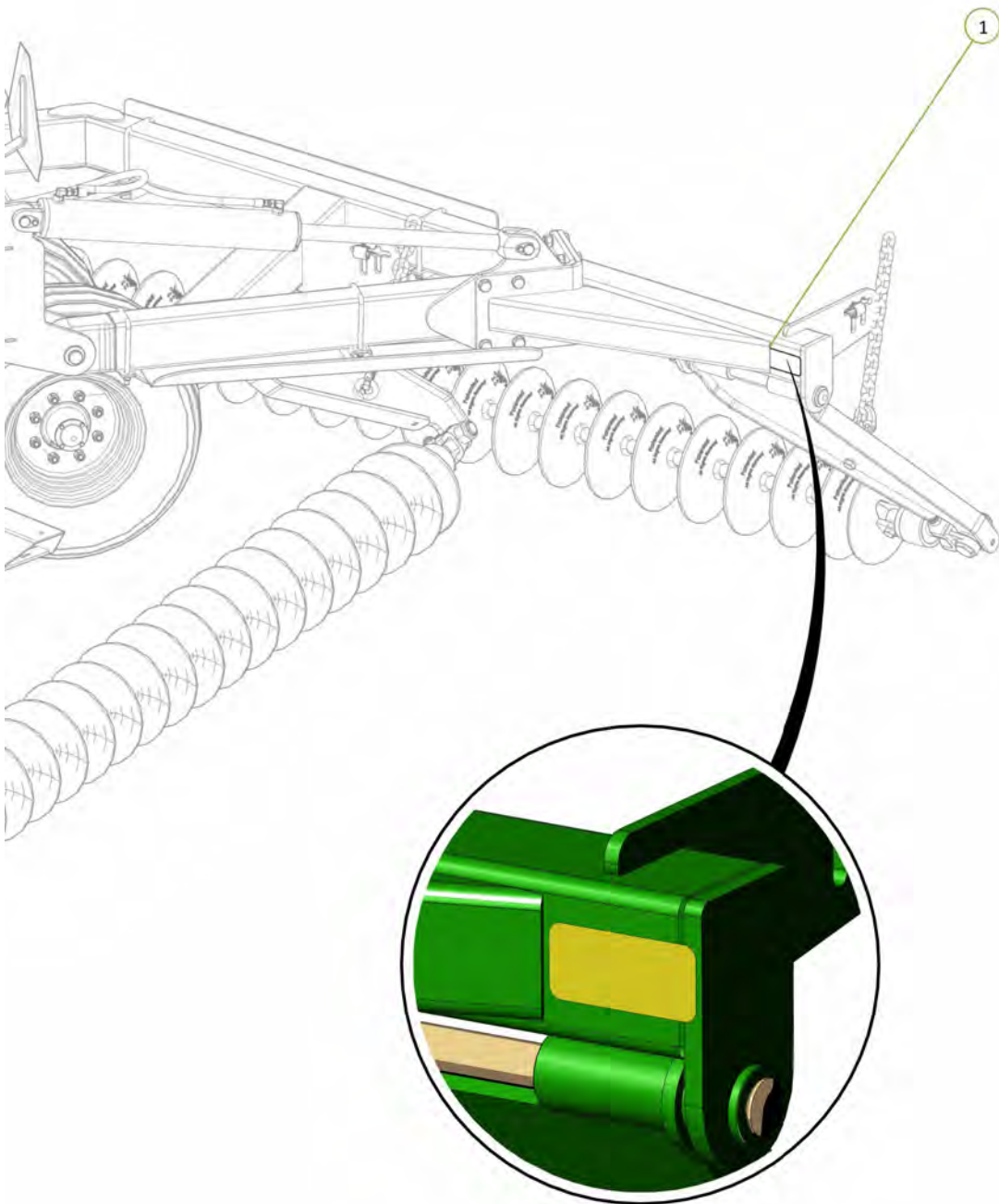

Item No.	Description	Number	Qty
1	Yellow Reflective Decal	0801-SYRF	1

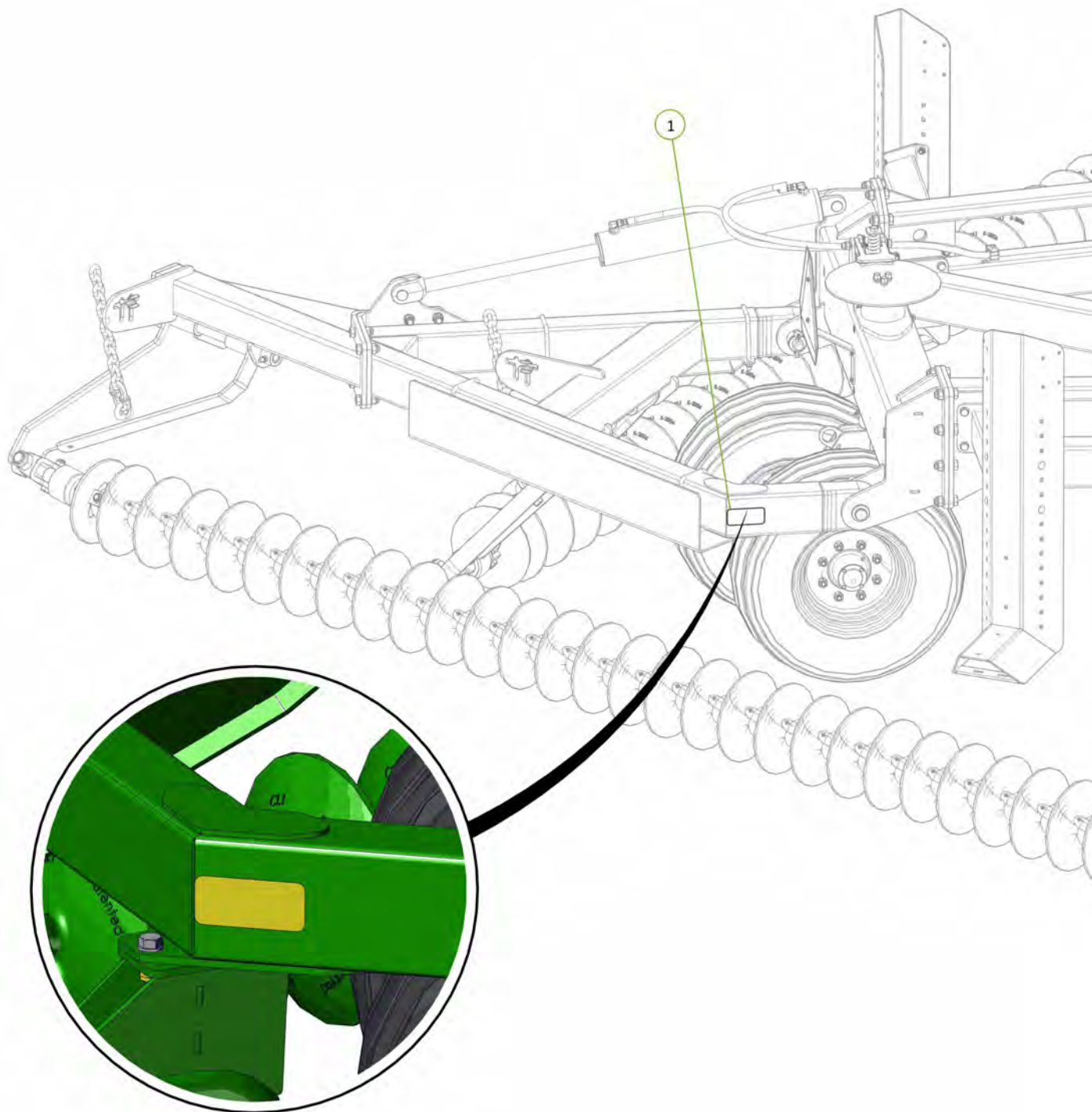

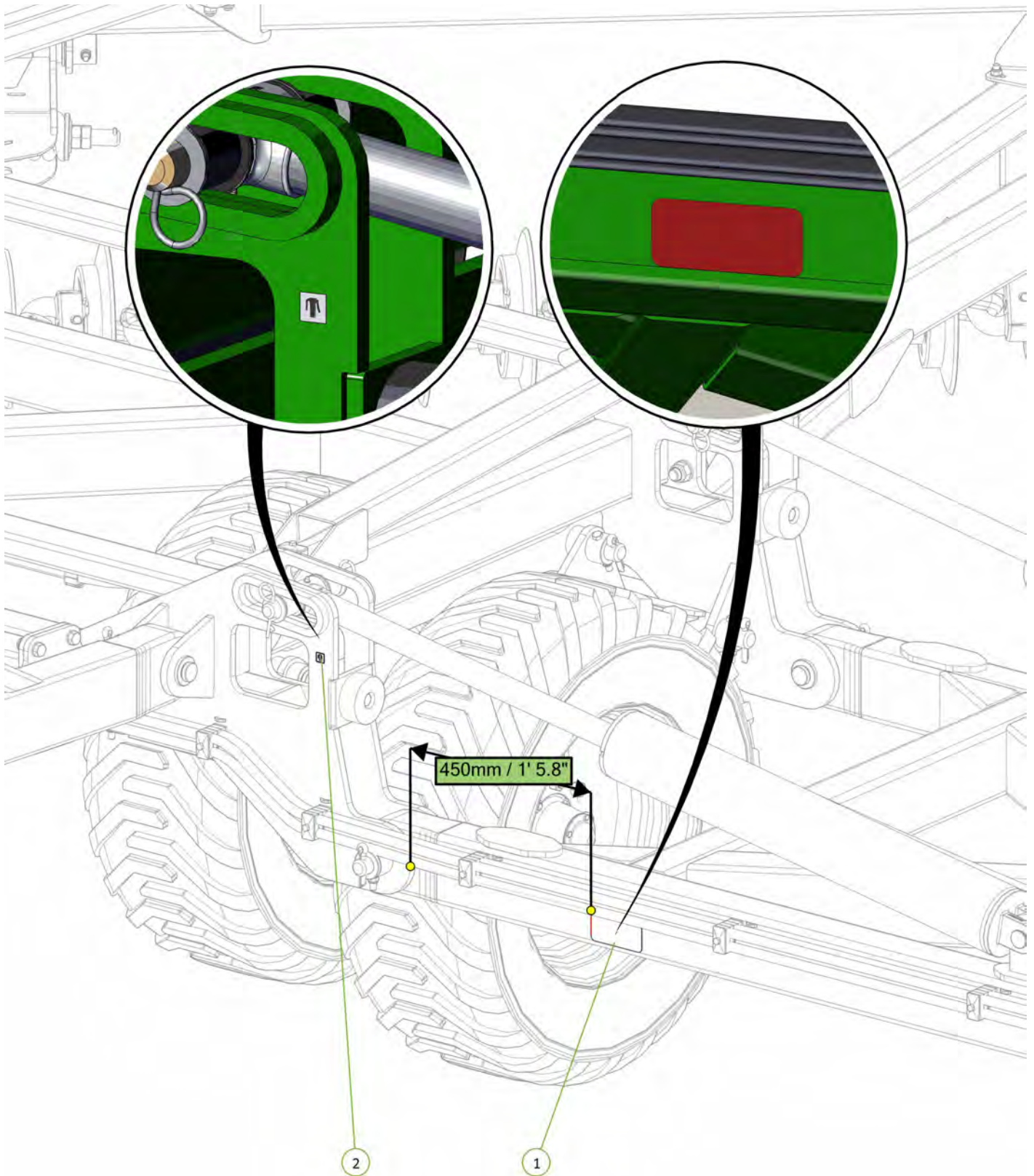

Item No.	Description	Number	Qty
1	Red Reflective Decal	0801-SRRF	1
2	Grease Decal	0801-S10	1



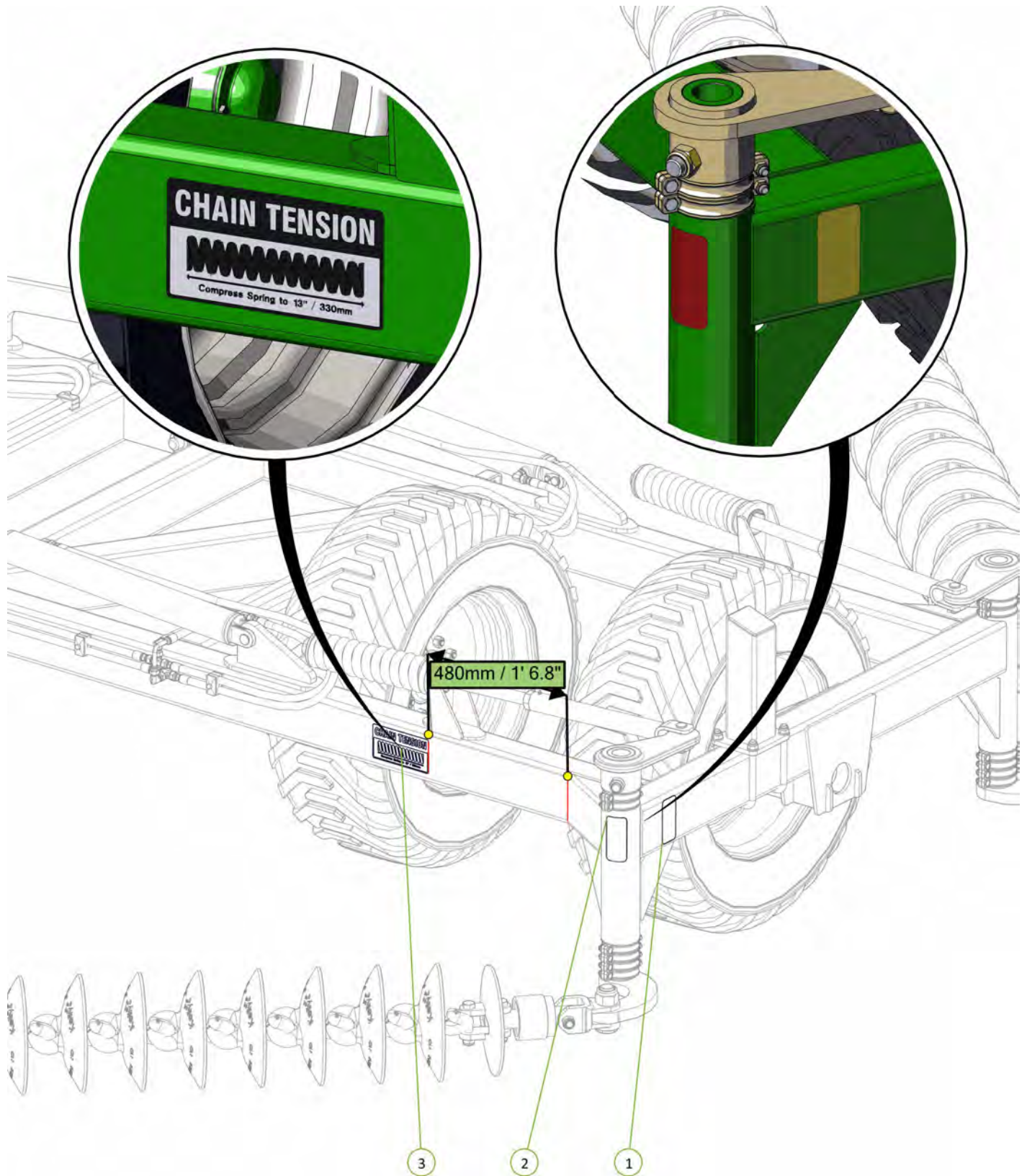

Item No.	Description	Number	Qty
1	Yellow Reflective Decal	0801-SYRF	1
2	Red Reflective Decal	0801-SRRF	1
3	Chain Tension 330mm Decal	0801-S15	1



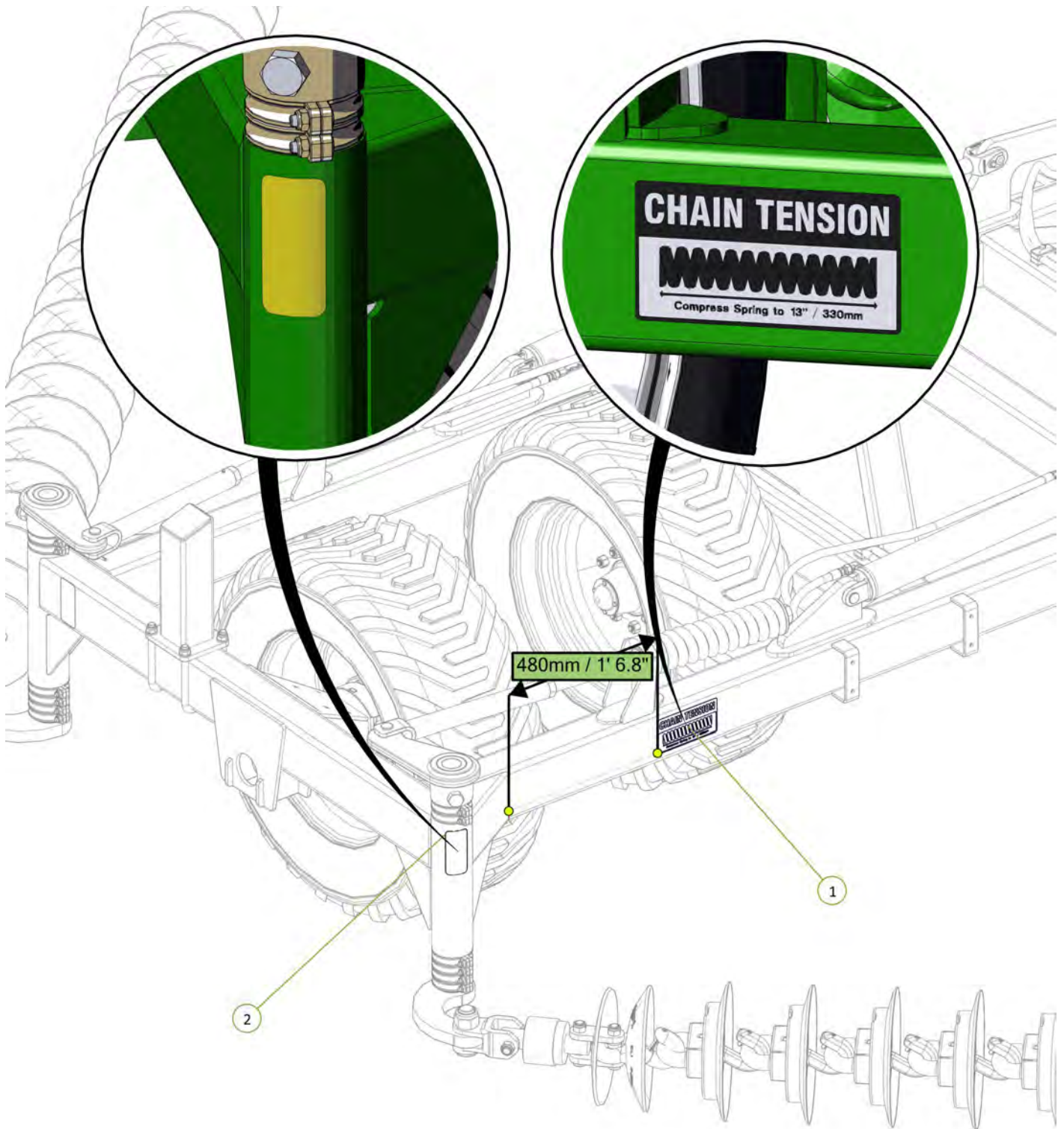

Item No.	Description	Number	Qty
1	Chain Tension 330mm Decal	0801-S15	1
2	Yellow Reflective Decal	0801-SYRF	1



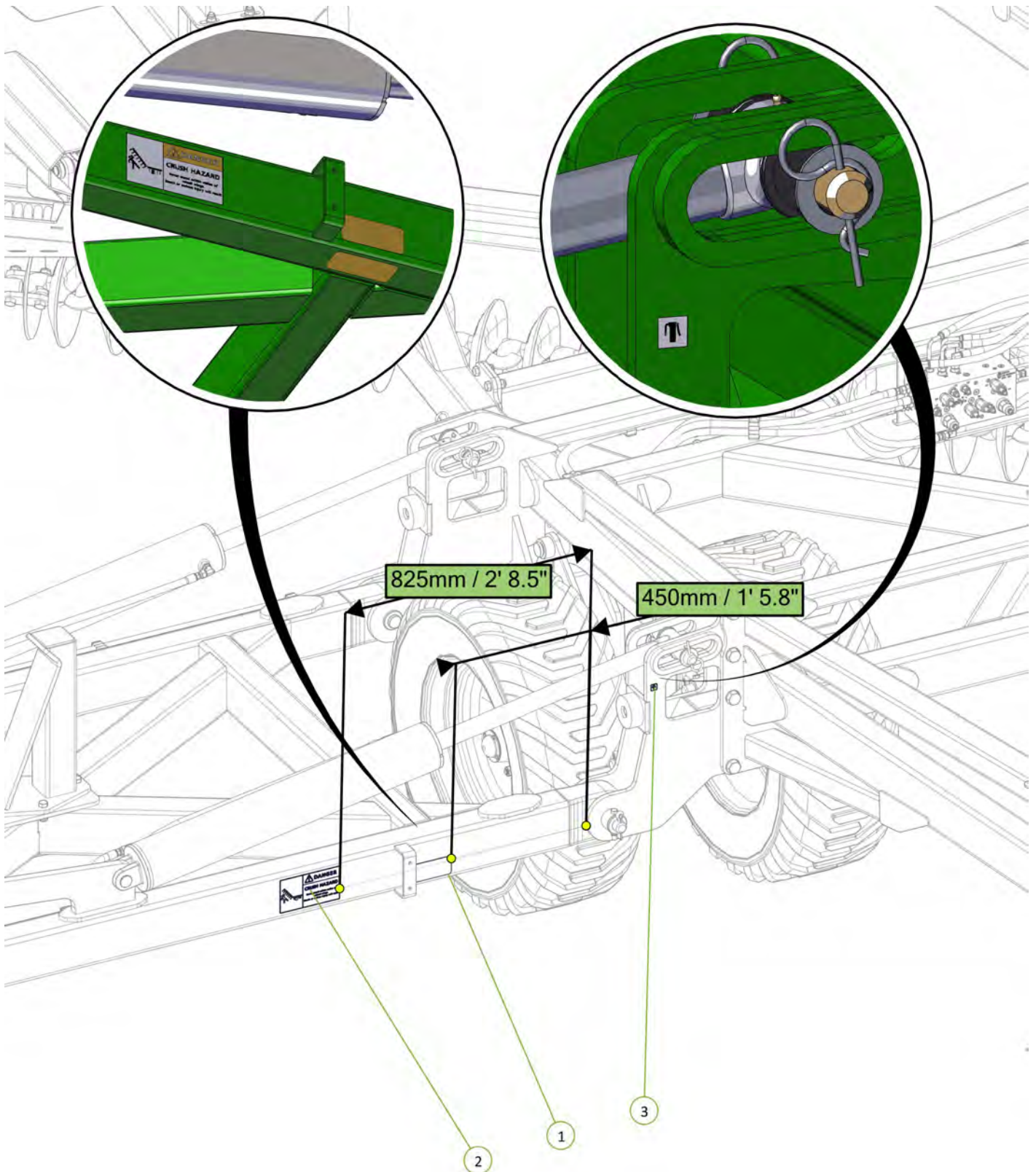

Item No.	Description	Number	Qty
1	Yellow Reflective Decal	0801-SYRF	2
2	Danger Crush Hazard Decal	0801-S3	1
3	Grease Decal	0801-S10	1



Item No.	Description	Number	Qty
1	400/55/22.5 Tyre Inflation Decal	0801-S8-400-55-22.5	8
2	Wheel Nut Decal	0801-S9	8

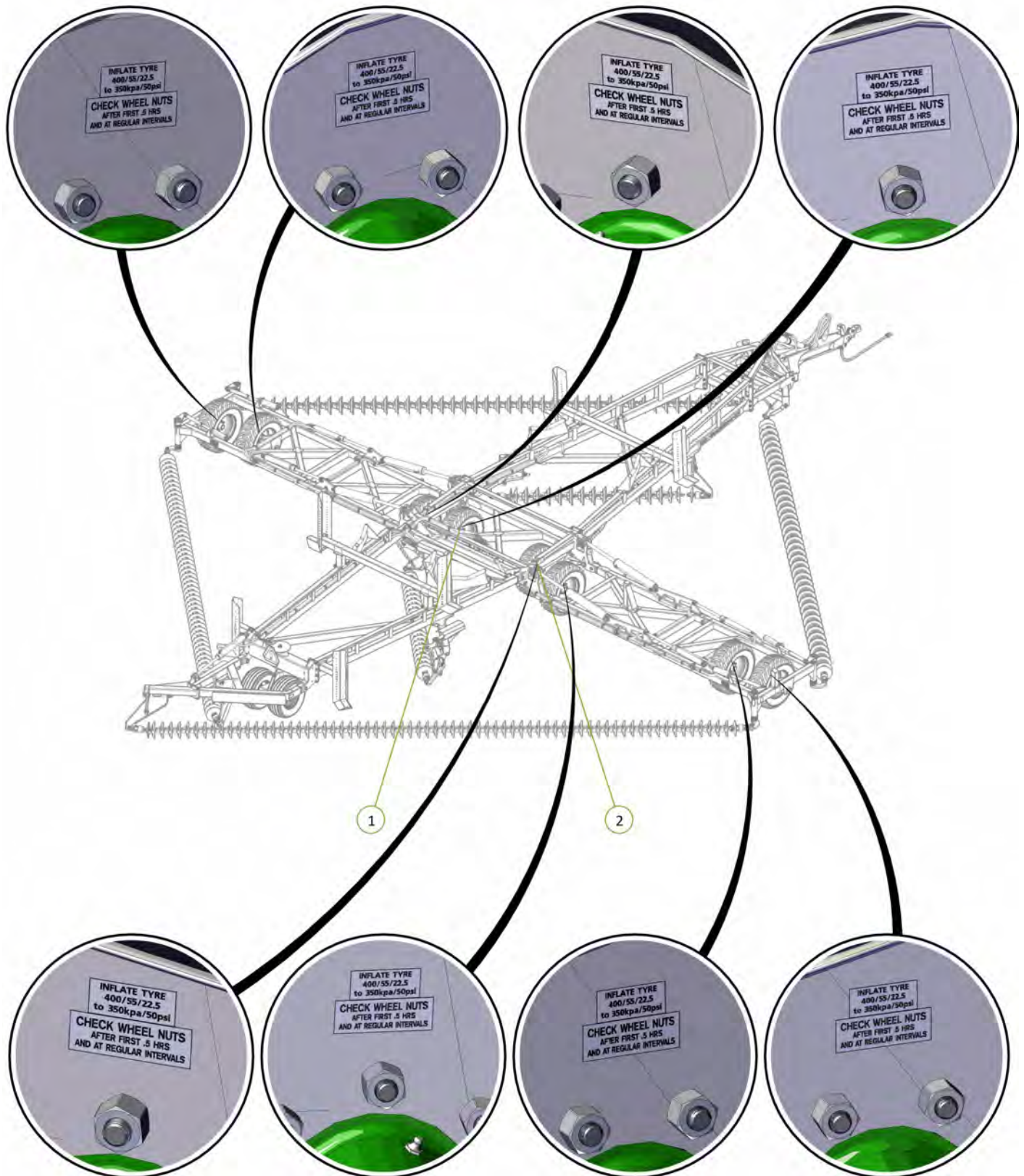

Item No.	Description	Number	Qty
1	Decal, 31/13.5/15 Tyre Inflation	0801-S8-31-13.5-15	2
2	Wheel Nut Decal	0801-S9	2

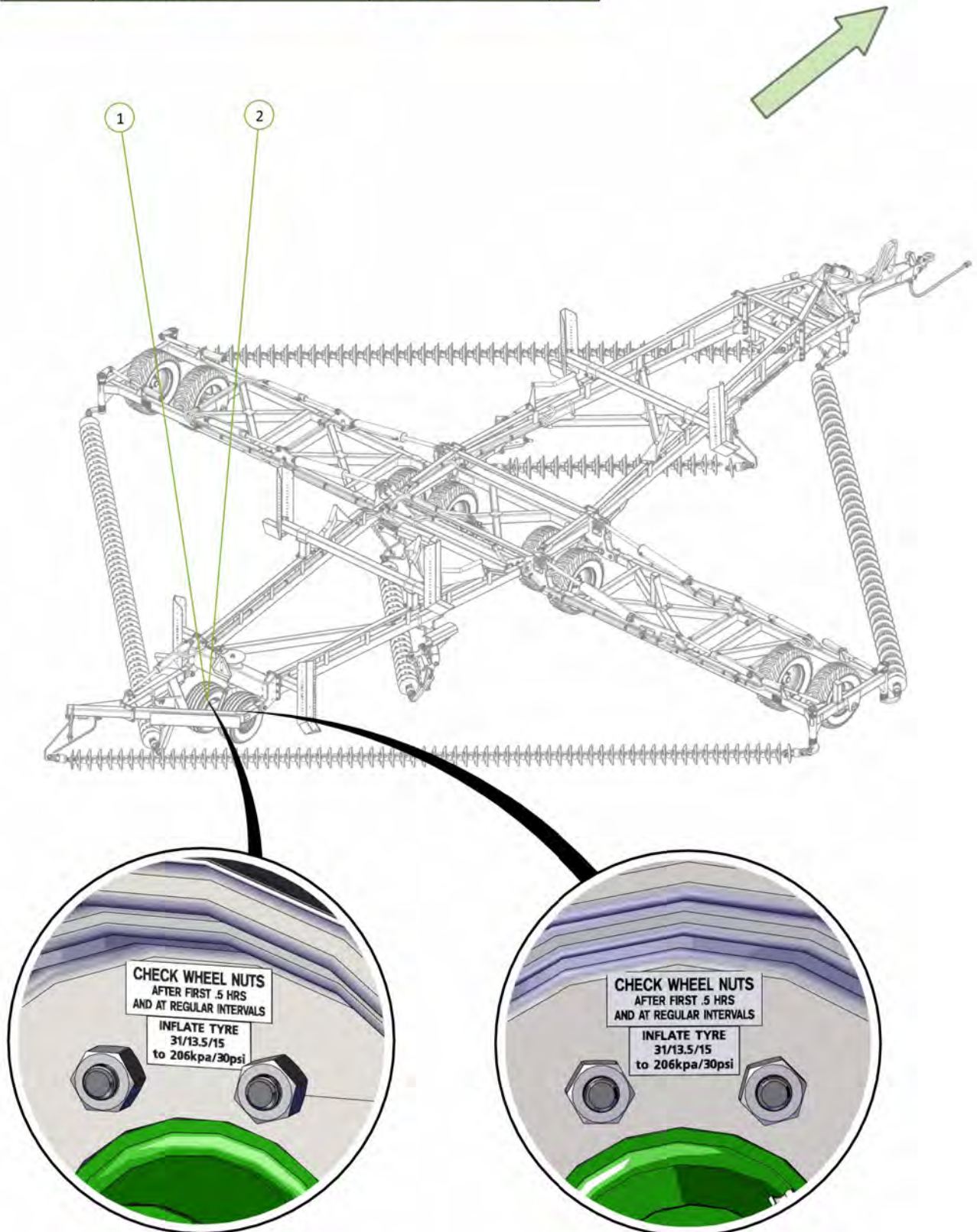

KELLY

Section 4 - Light Kit

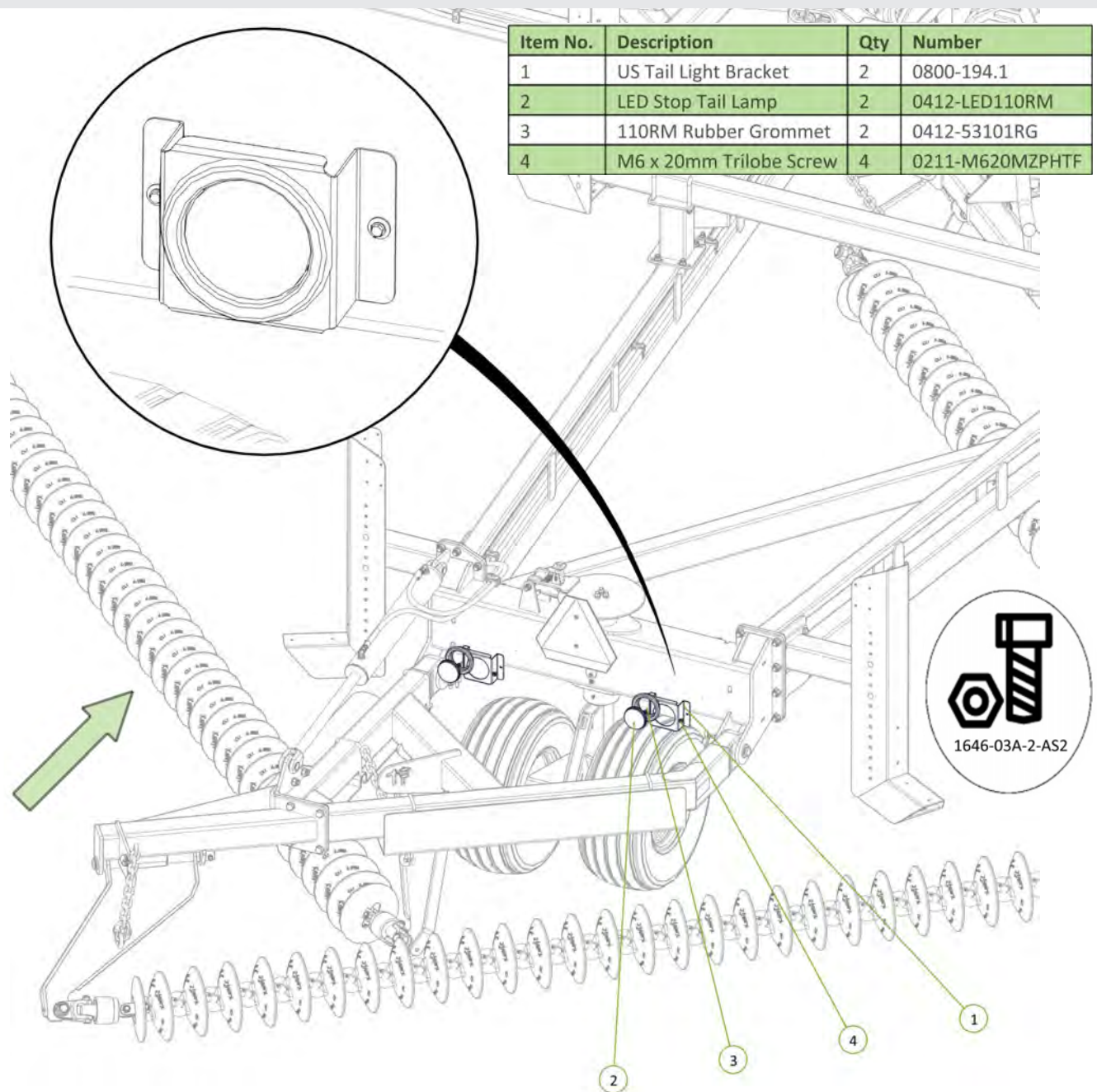

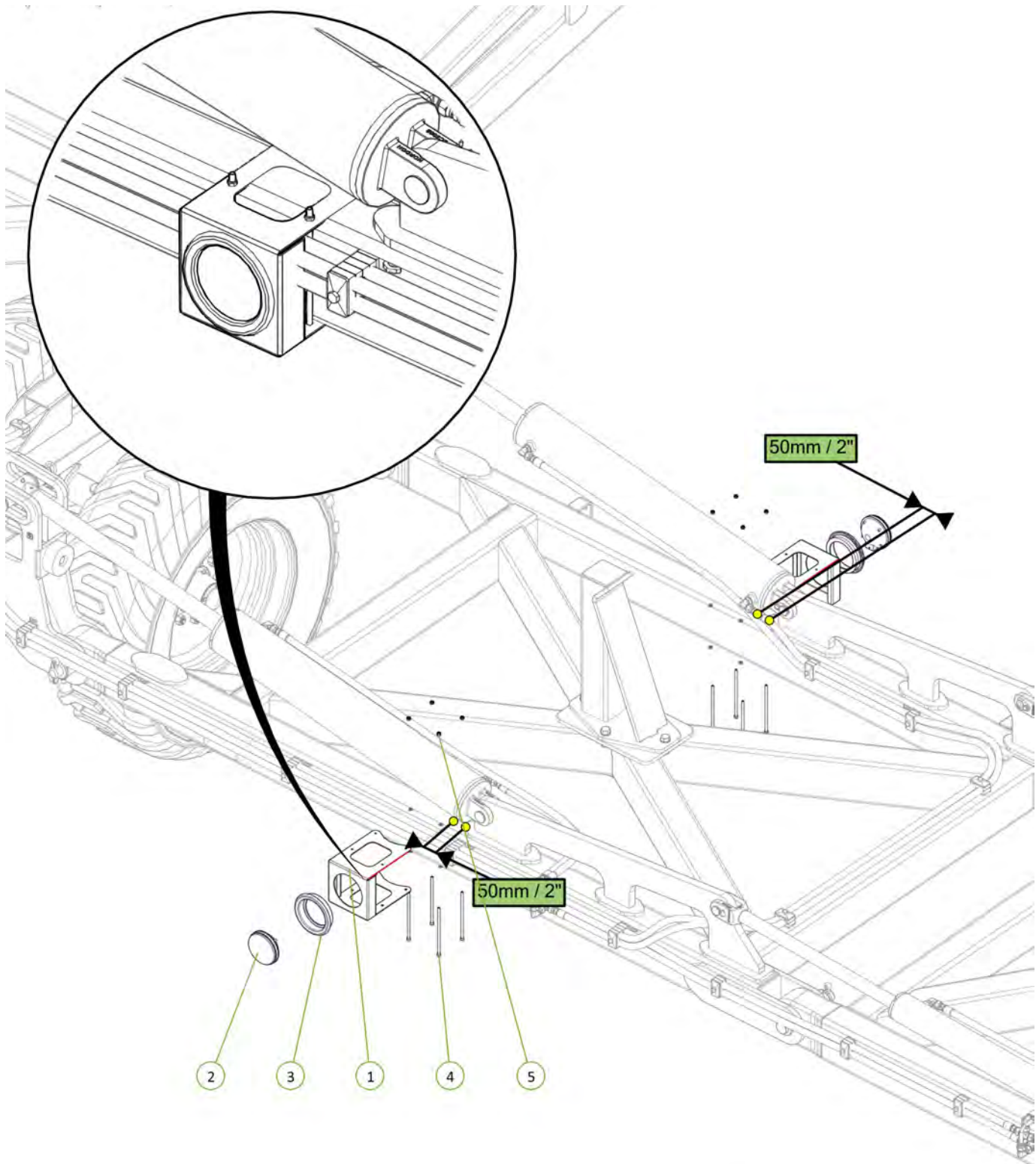

Item No.	Description	Qty	Number
1	Wing light bracket	2	0800-296
2	LED Rear Indicator Lamp	2	0412-LED110AM
3	110RM Rubber Grommet	2	0412-53101RG
4	Socket Head Bolt M6 x 170 zp	8	0211-SH6170
5	Nyloc Nut M6	8	0221-NYL6



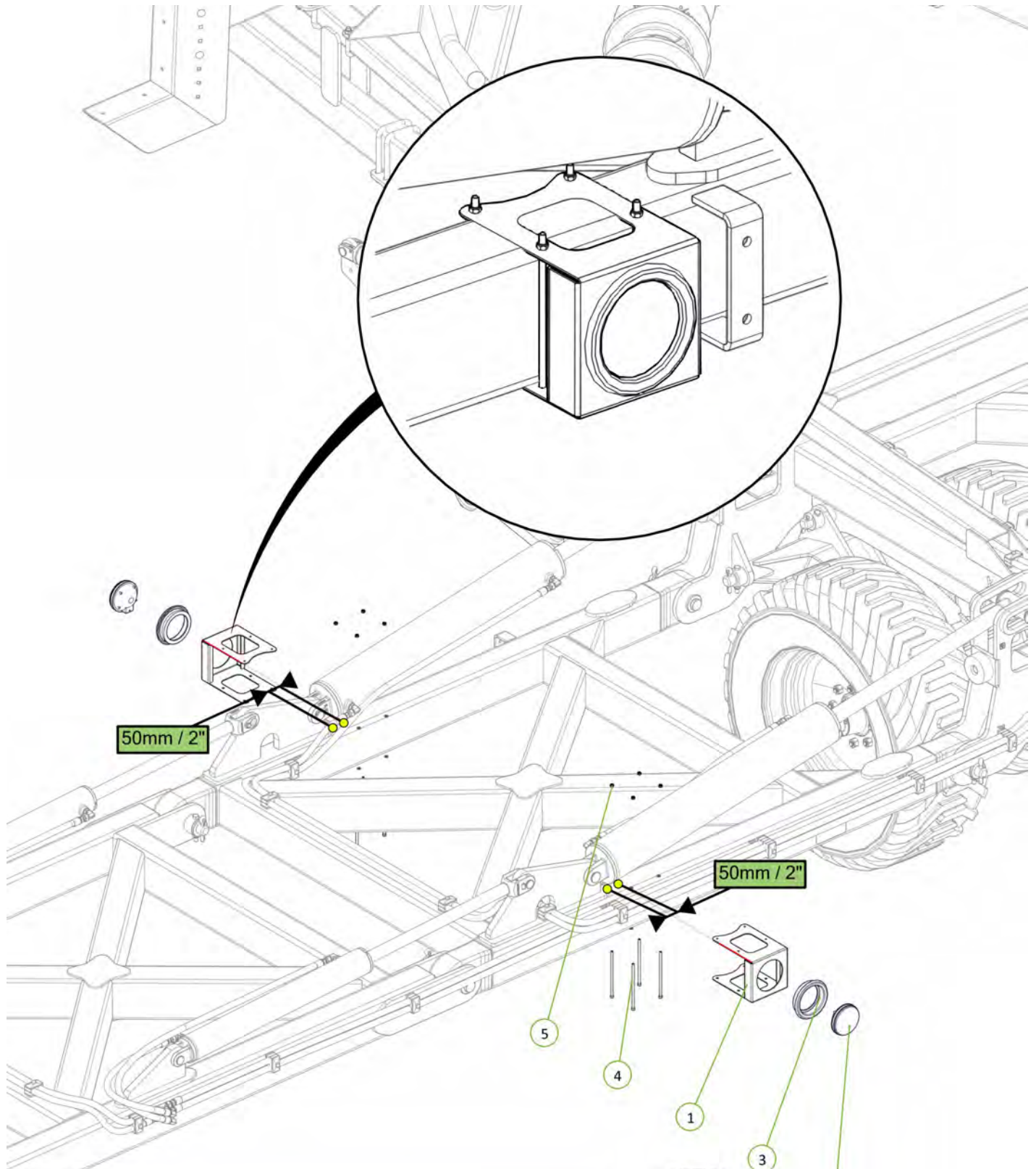

Item No.	Description	Qty	Number
1	Wing light bracket	2	0800-296
2	LED Rear Indicator Lamp	2	0412-LED110AM
3	110RM Rubber Grommet	2	0412-53101RG
4	Socket Head Bolt M6 x 170 zp	8	0211-SH6170
5	Nyloc Nut M6	8	0221-NYL6



Item No.	Description	Qty	Number
1	Electrical Plug Keeper	1	0416-11750B
2	M6 x 25 Class 8.8 ZP Bolt	2	0211-625
3	Washer Flat M6	2	0231-F6
4	Nyloc Nut M6	2	0221-NYL6

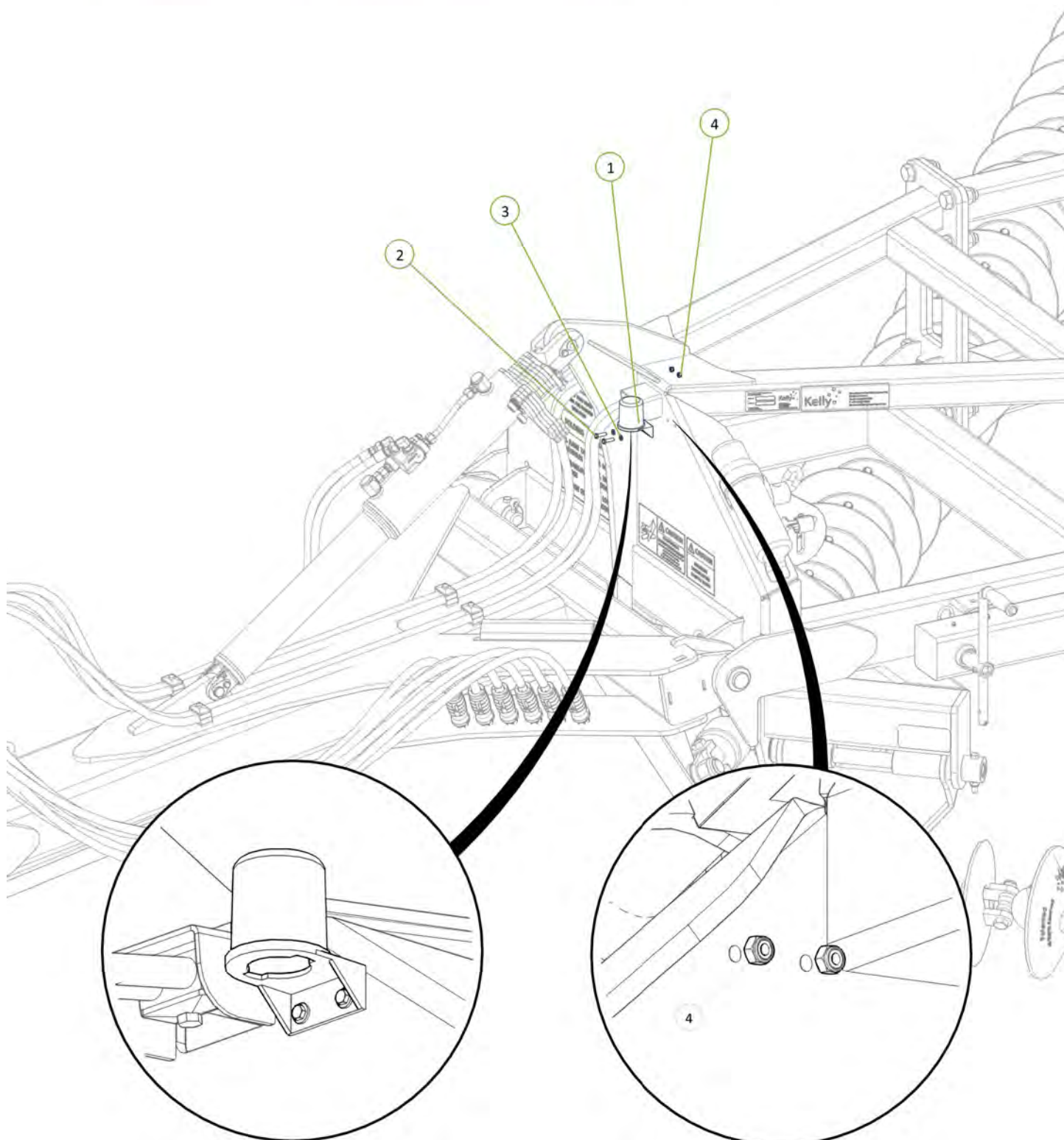

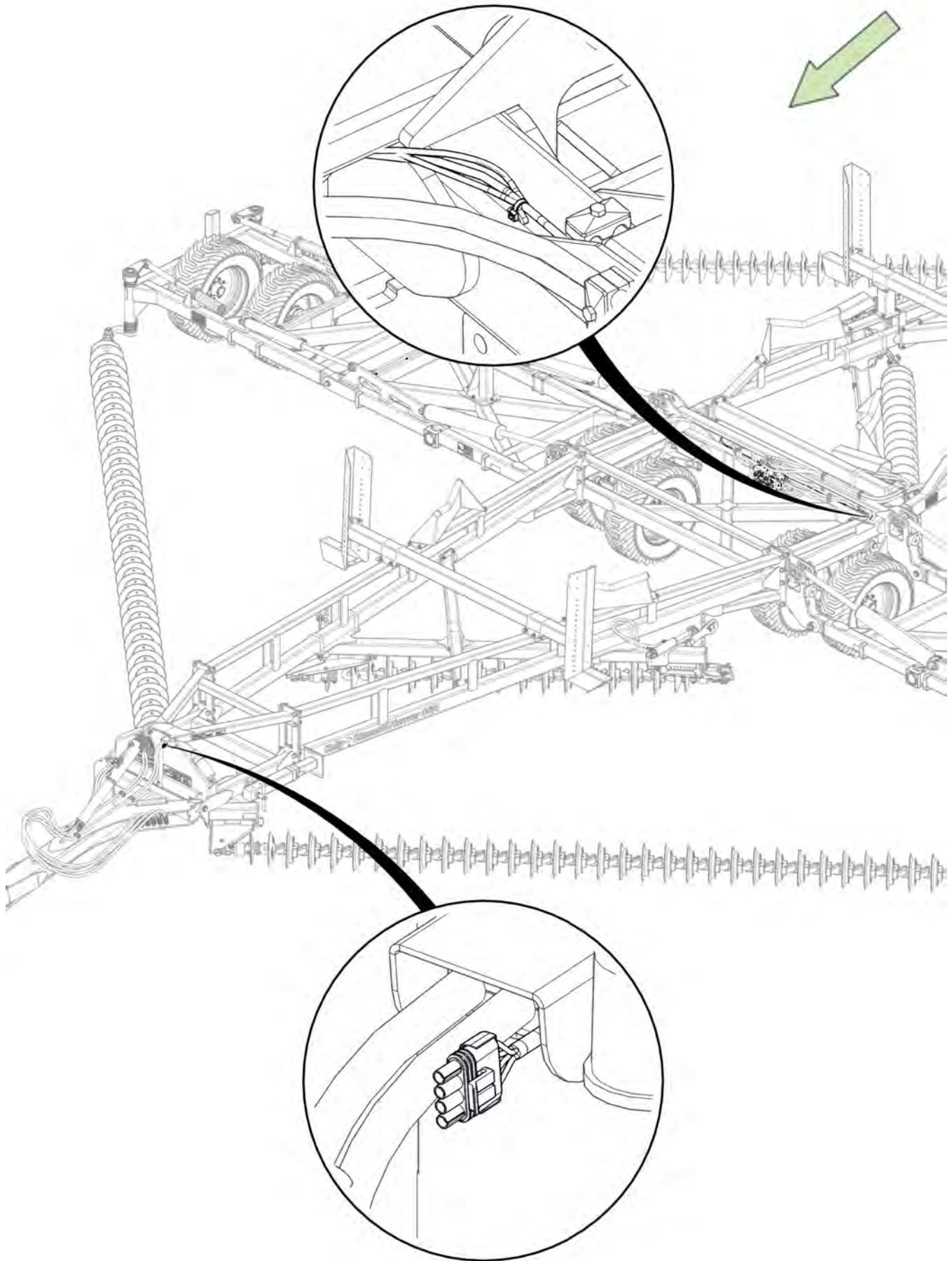

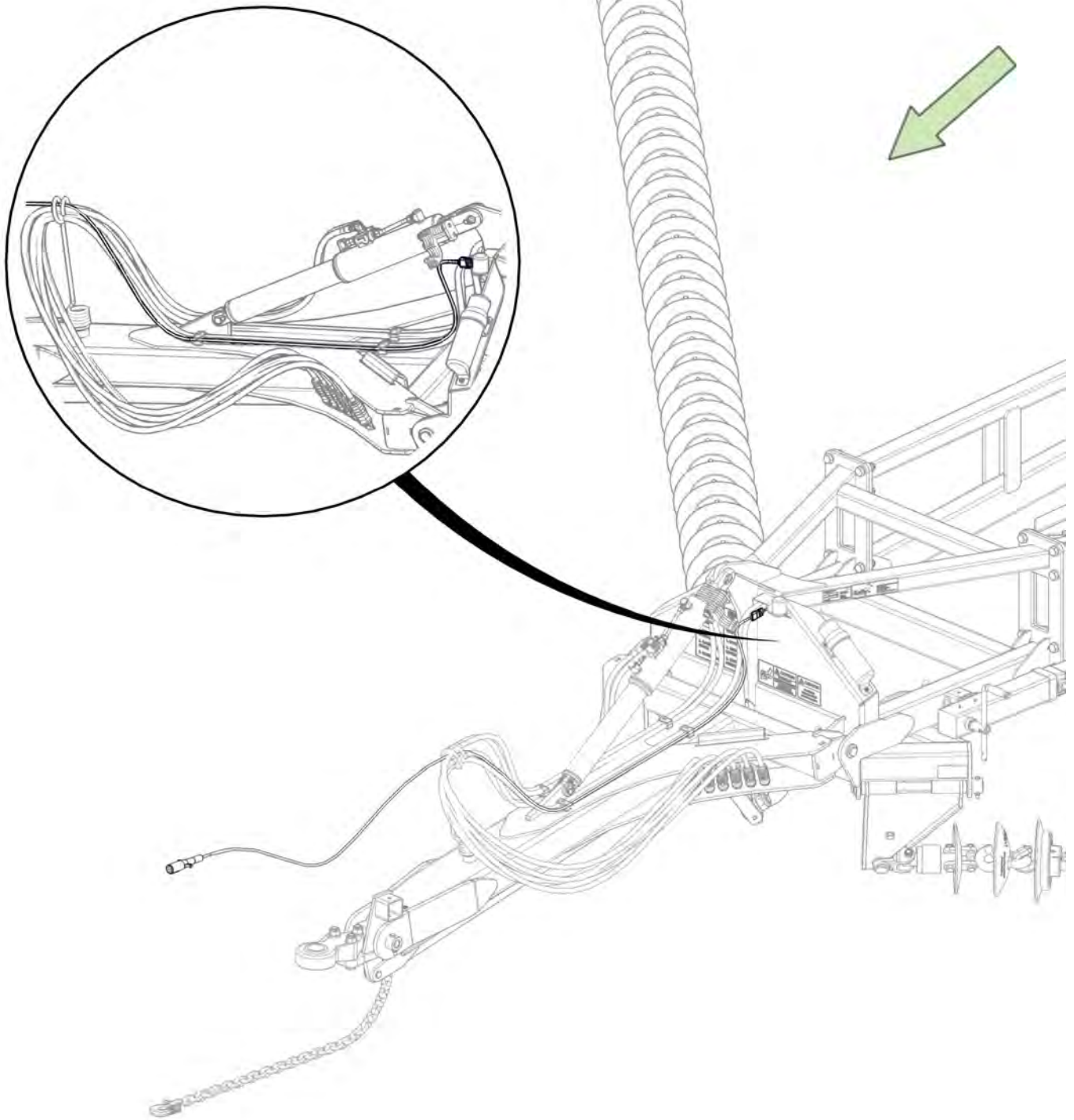

Where required secure loom to hydraulic hoses or tabs provided

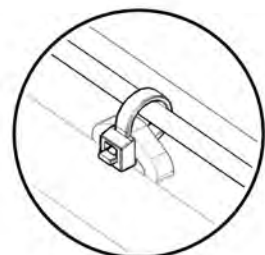

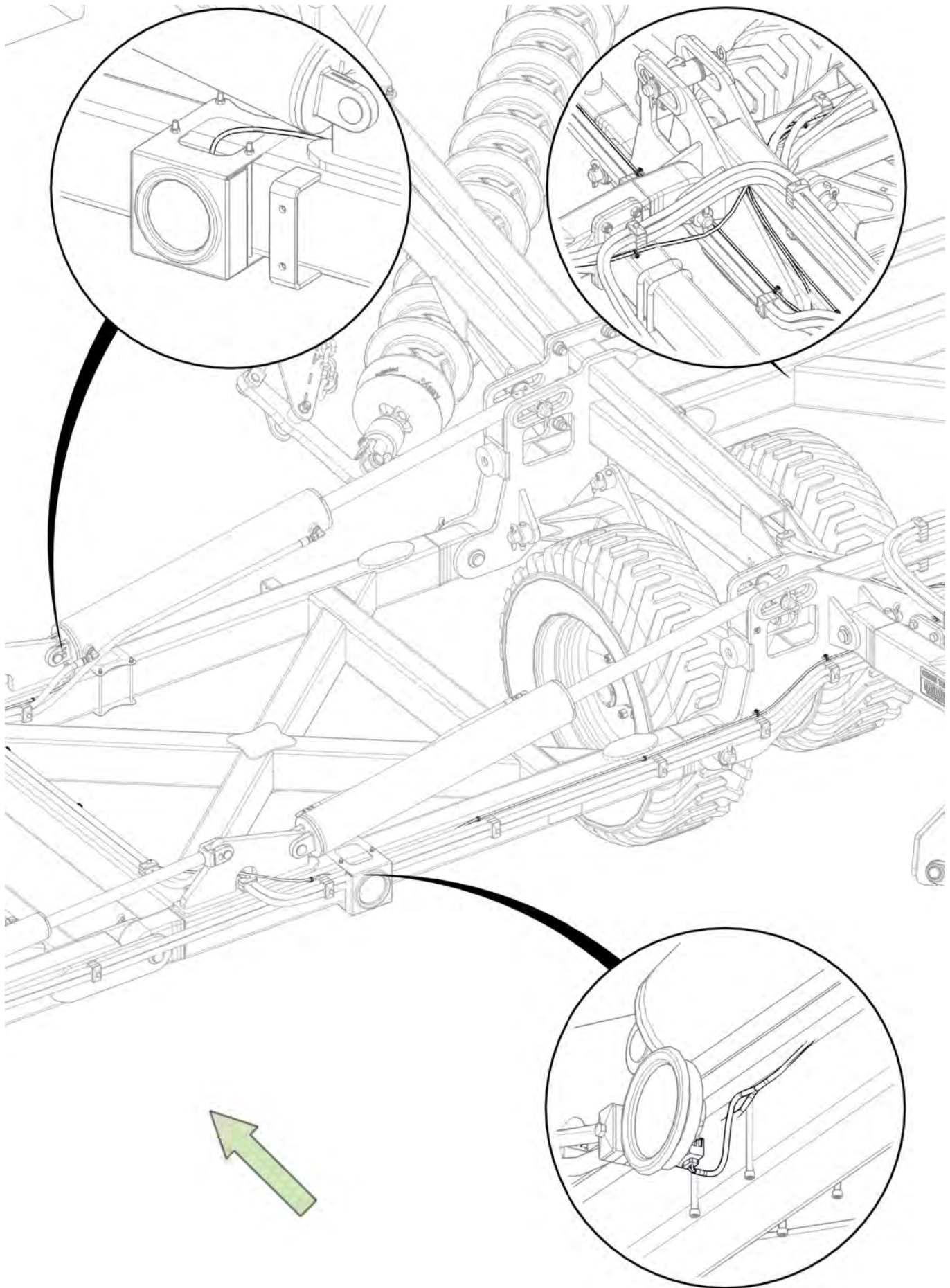

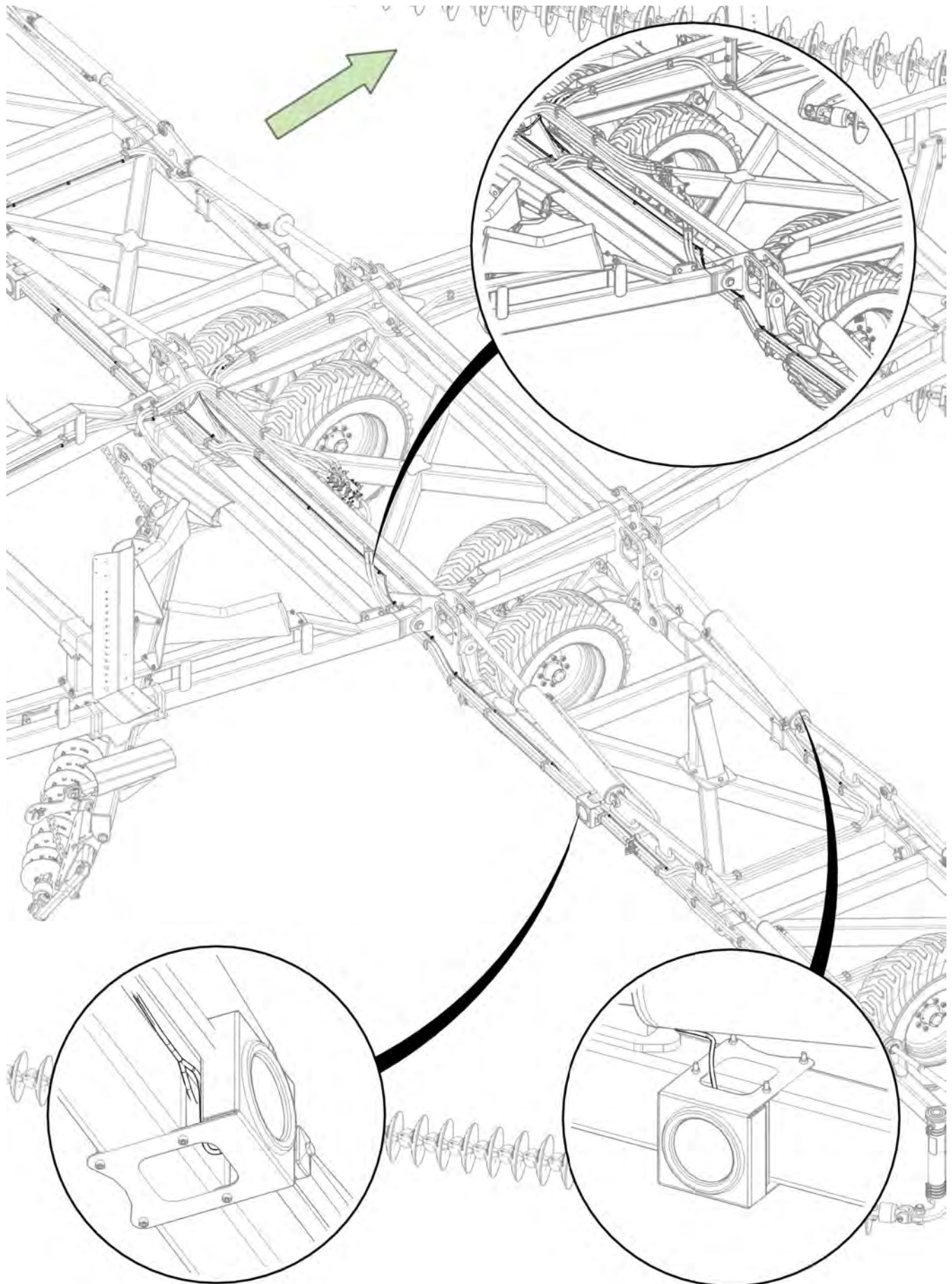

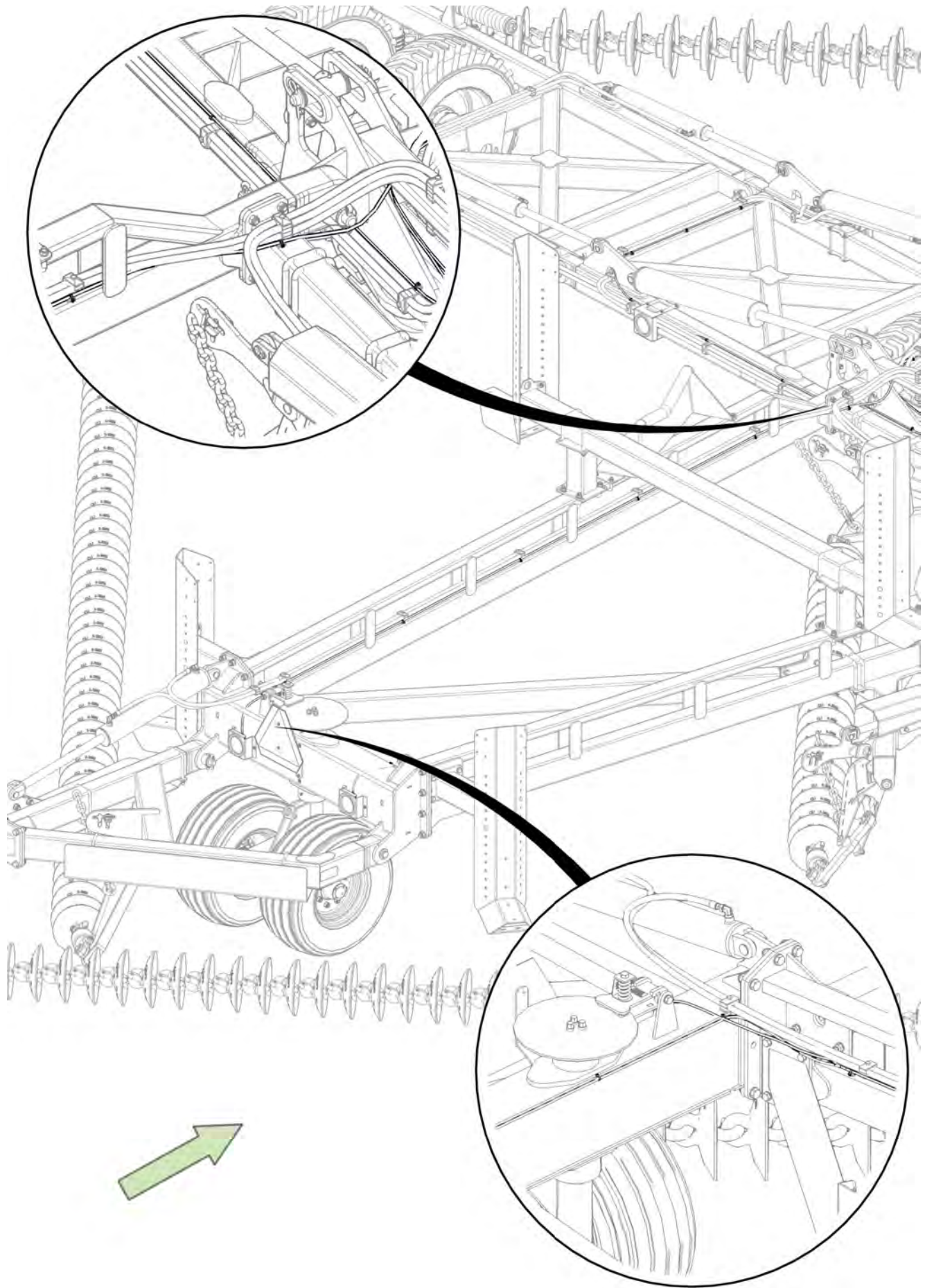

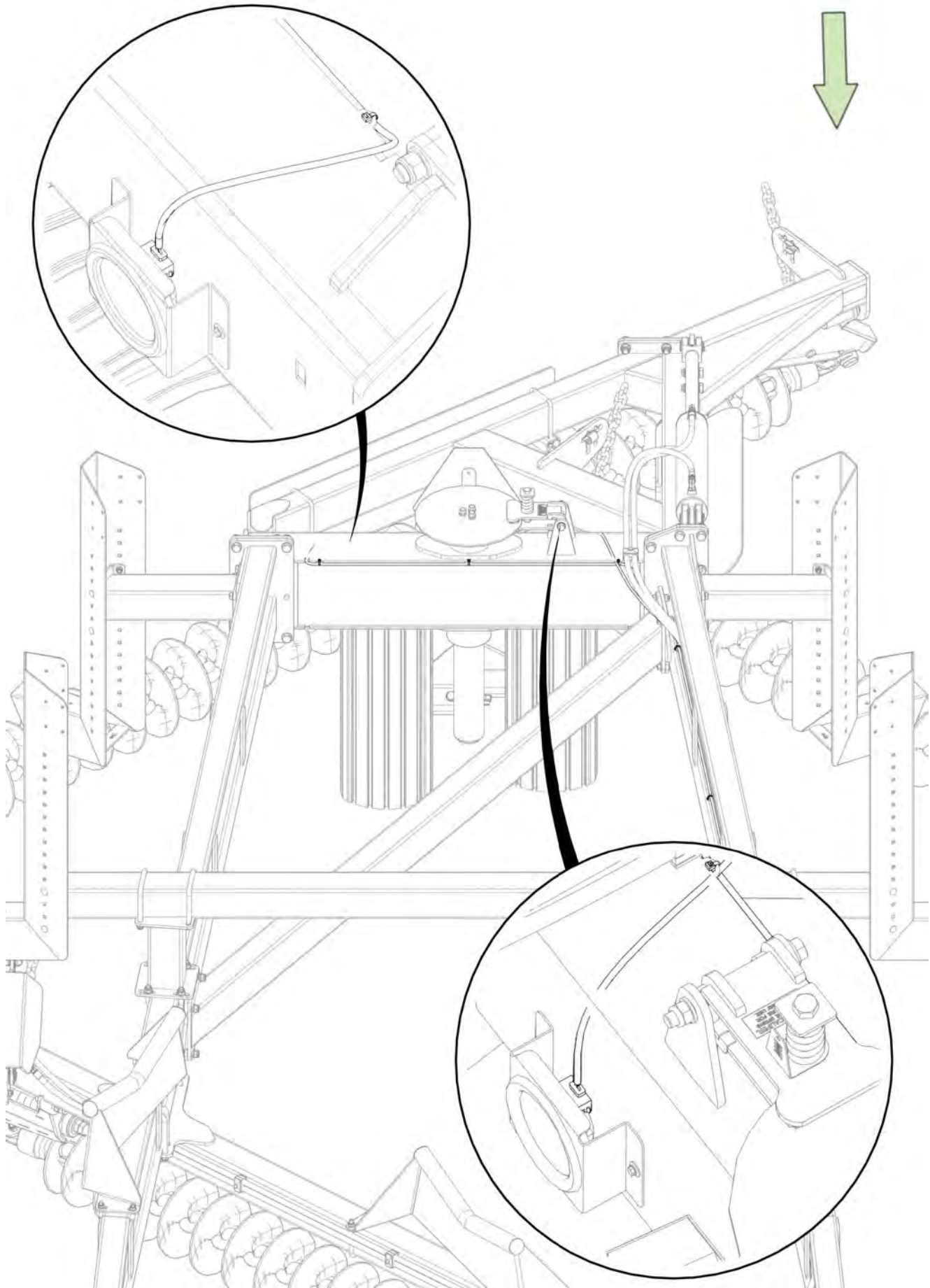



Section 5 - Chain Assembly

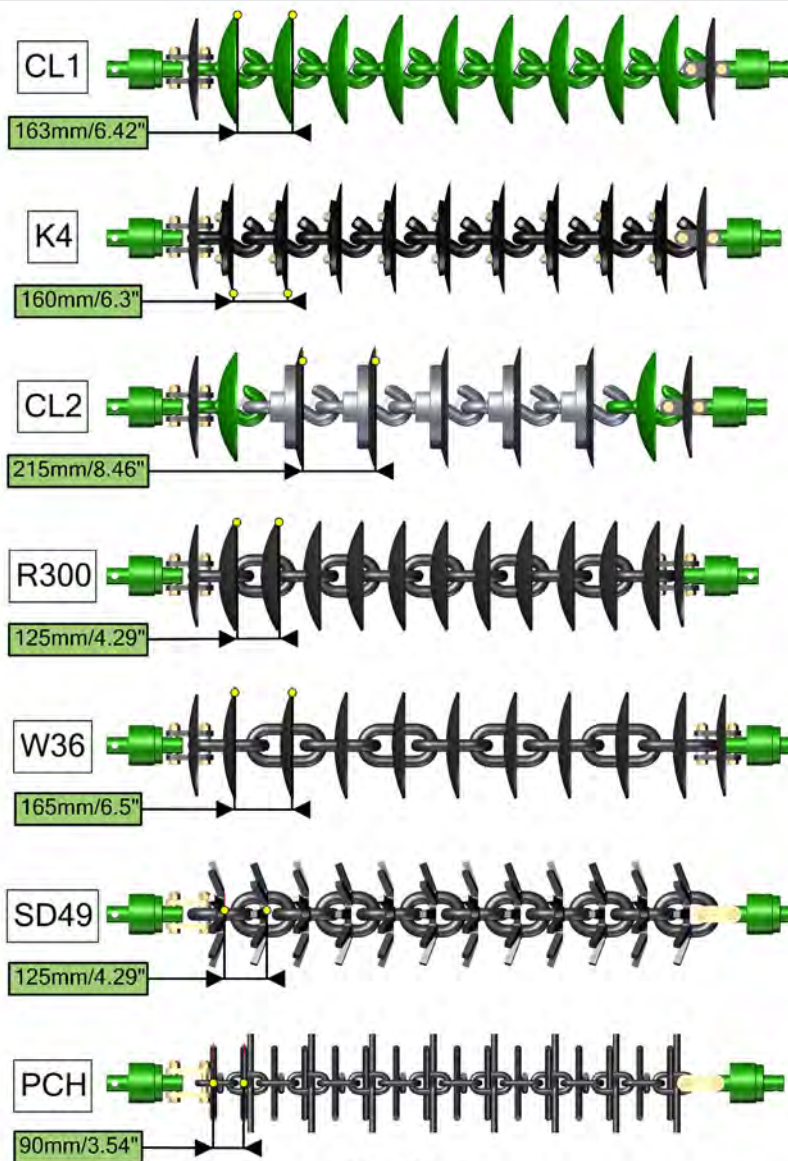

CL1 Disc Chain - unhook disc chain link/s from end of the disc chain

Item No.	Description	Number
1	Nyloc Nut M20	0221-NYL20
2	M20 x 110 Class 10.9 ZP Short Thread Bolt	0211-20110ST
3	20mm Bolt Swivel Unit	0802-PCHB55
4	Tie Plate Disc 20mm	0802-DCTP-20
5	Disc Chain Spacer	0801-253755
6	Roll Pin Zinc Plated 3/8" x 2"	0262-3-8X2
7	CL1-B Chain Disc Link	0803-CL1

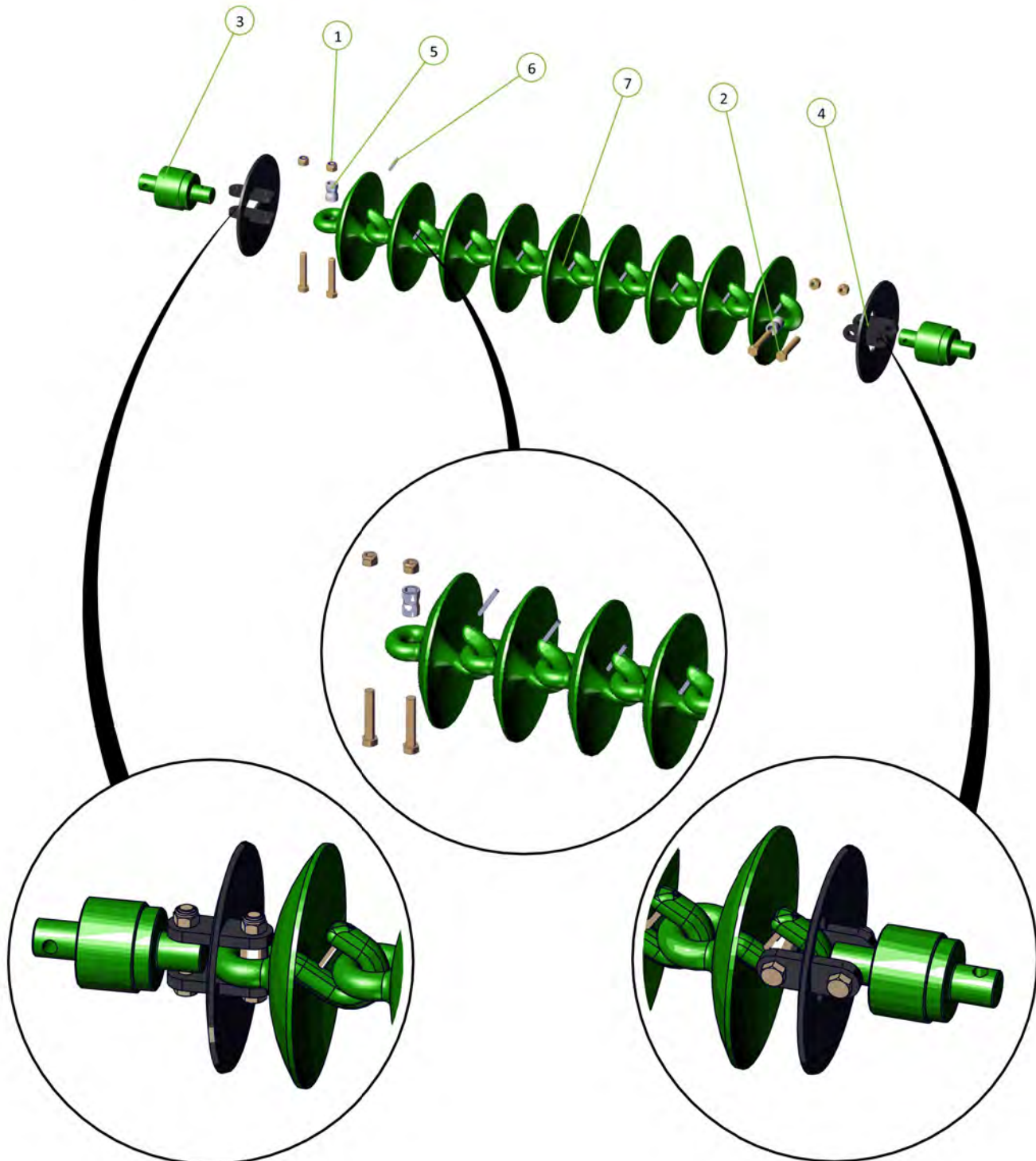

Fitting Cast Link Pins

Please install cast link retaining Pins (3/8" x 3" Roll Pin, part number 0262-3-8X3) on all cast disc links. Failure to do this could lead to the discs becoming dislodged during transport causing severe damage or injury.

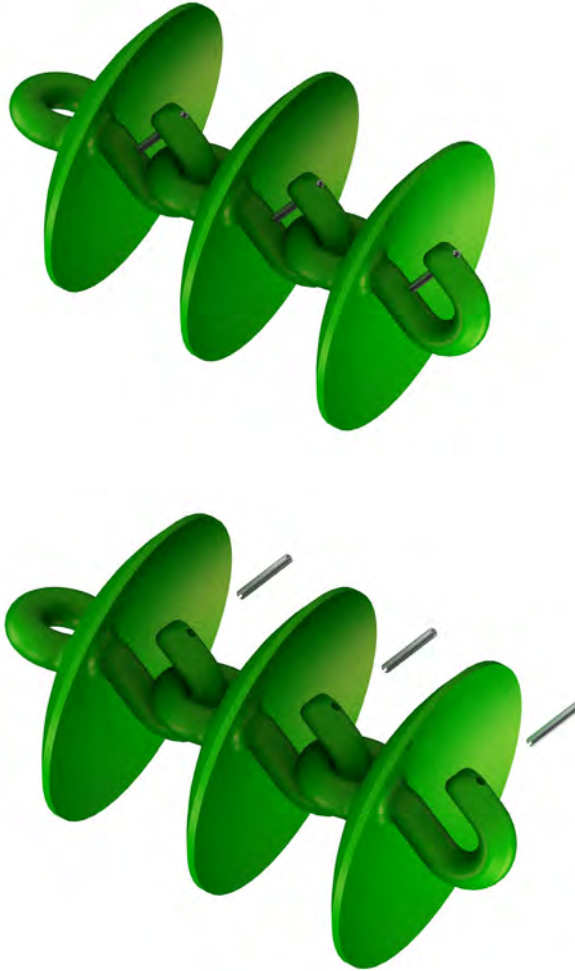

CL2 Disc Chain - unhook disc chain link/s from end of the disc chain

Item No.	Description	Number
1	Nyloc Nut M20	0221-NYL20
2	M20 x 110 Class 10.9 ZP Short Thread Bolt	0211-20110ST
3	20mm Bolt Swivel Unit	0802-PCHB55
4	Tie Plate Disc 20mm	0802-DCTP-20
5	Disc Chain Spacer	0801-253755
6	CL2-Link Assembly	0803-CL2
7	Roll Pin Zinc Plated 3/8" x 2"	0262-3-8X2
8	CL1 Disc Chain Link	0803-CL1

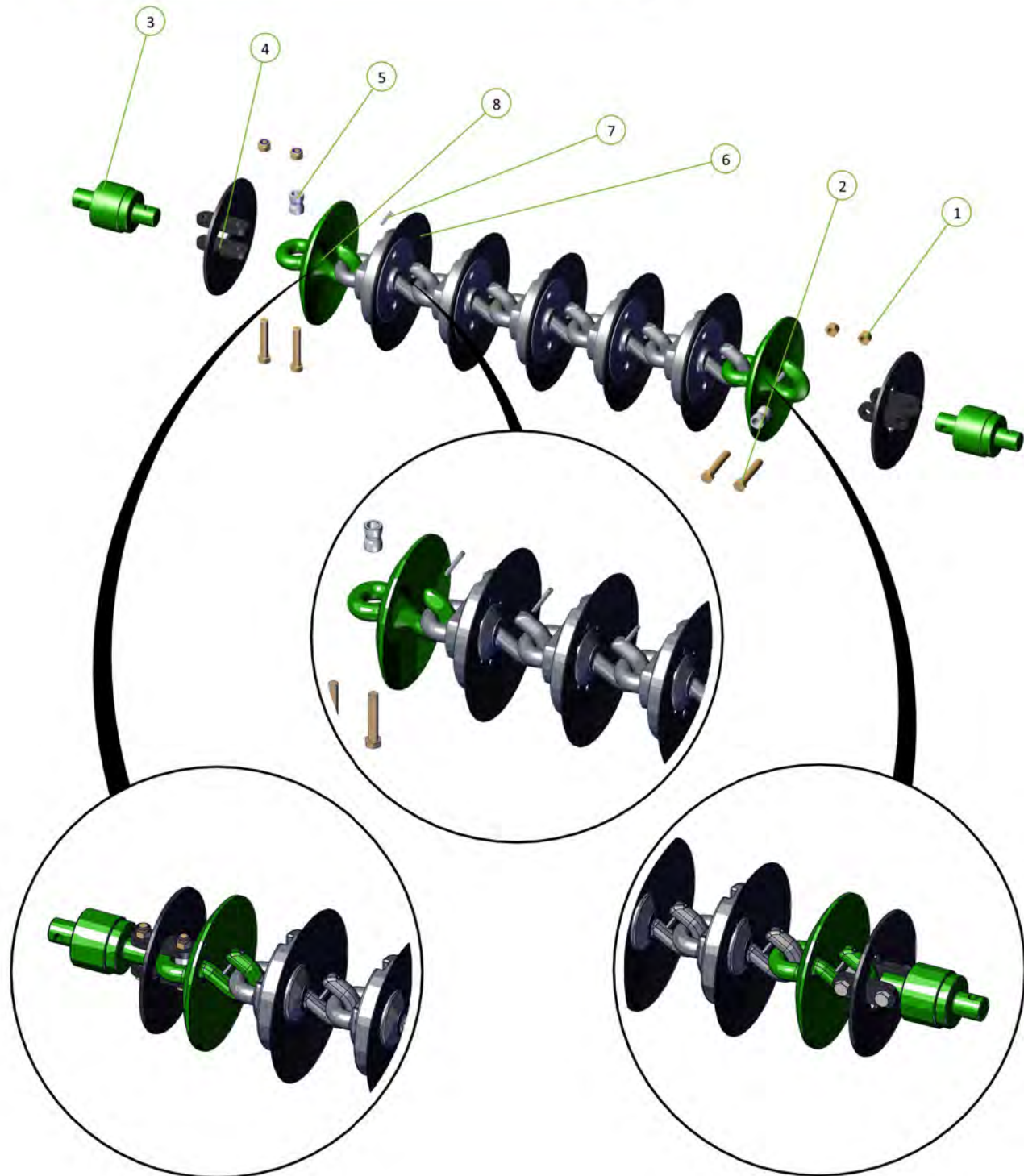

CL2 Chain Layout

Set	CL2	CL1
Front Left	38	2
Front Right	38	2
Front Modules	13	3
Front Set	89	7
Rear Right	40	15
Rear Left	40	2
Rear Modules	14	2
Rear Set	94	19
Total	183	24

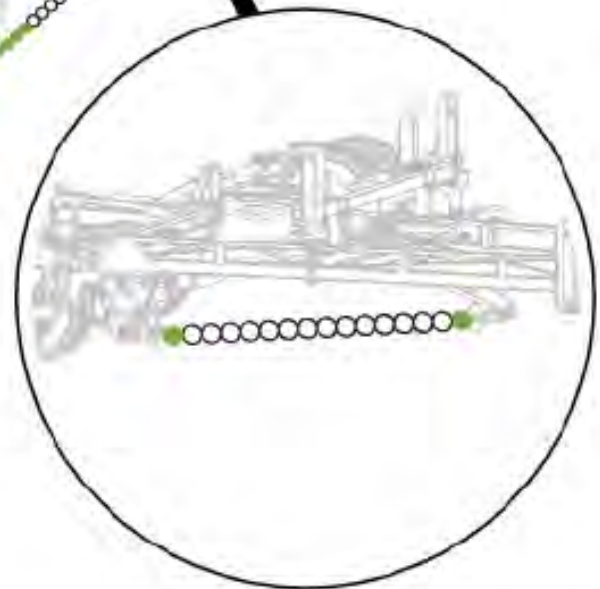
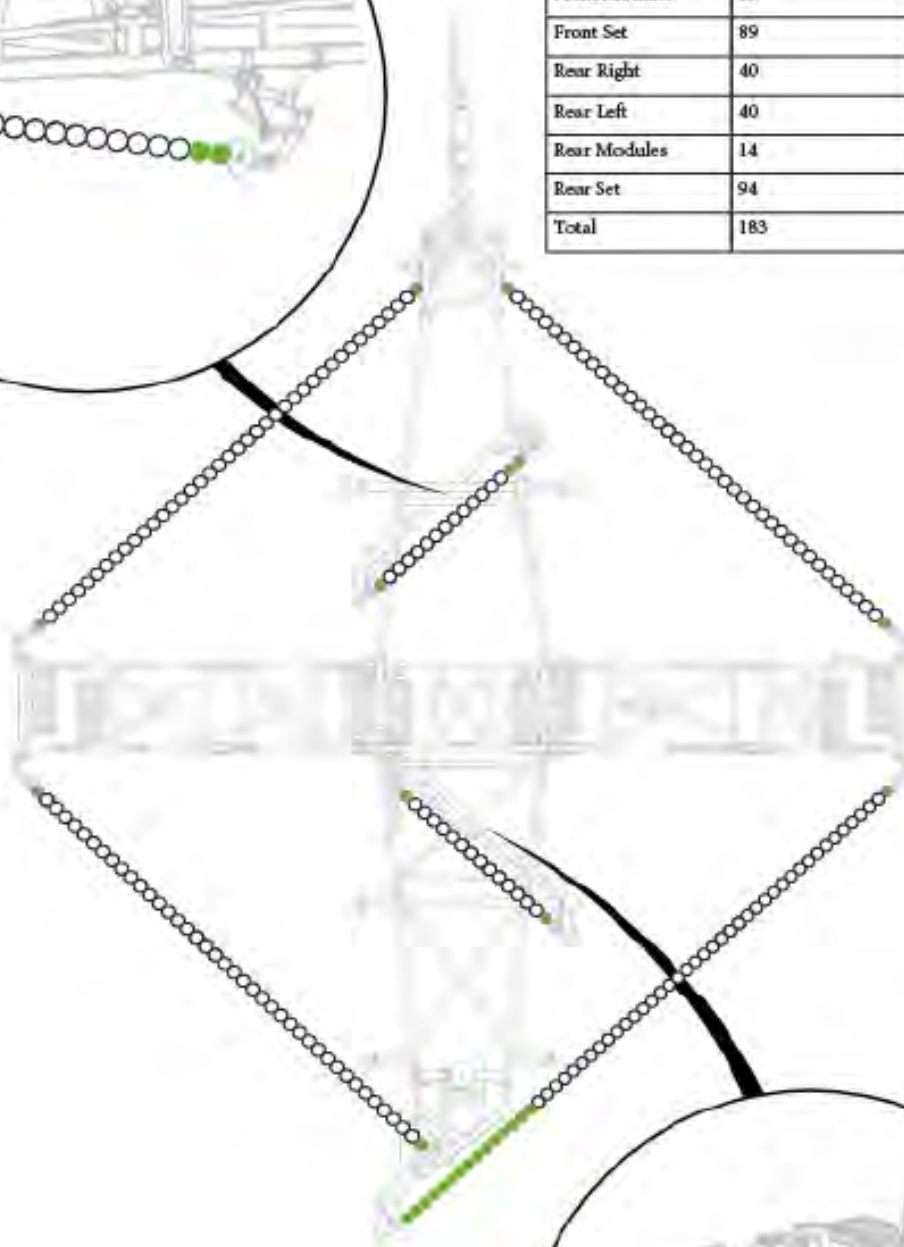
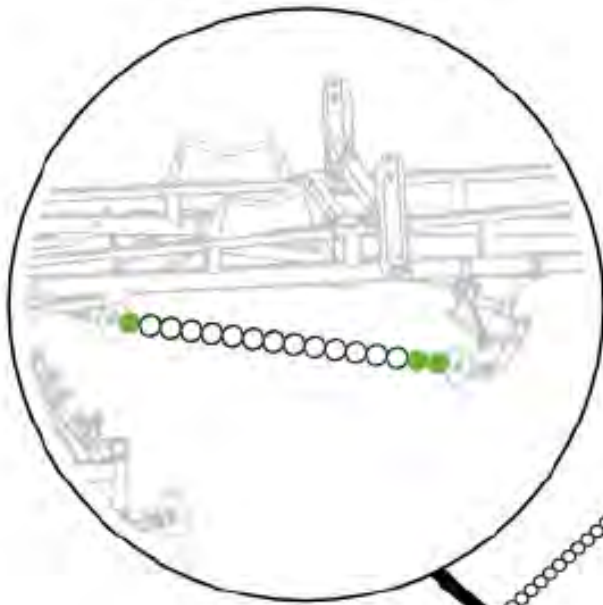

Item No.	Description	Number
1	Nyloc Nut M20	0221-NYL20
2	M20 x 110 Class 10.9 ZP Short Thread Bolt	0211-20110ST
3	20mm Bolt Swivel Unit	0802-PCHB55
4	Tie Plate Disc 20mm	0802-DCTP-20
5	Disc Chain Spacer	0801-253755
6	K4 Disc Assembly	0803-K4
7	M12 x 55 Class 8.8 ZP Bolt	0211-1255
8	Nyloc Nut M12	0221-NYL12



K4 Disc Chain - unhook disc chain link/s from end of the disc chain

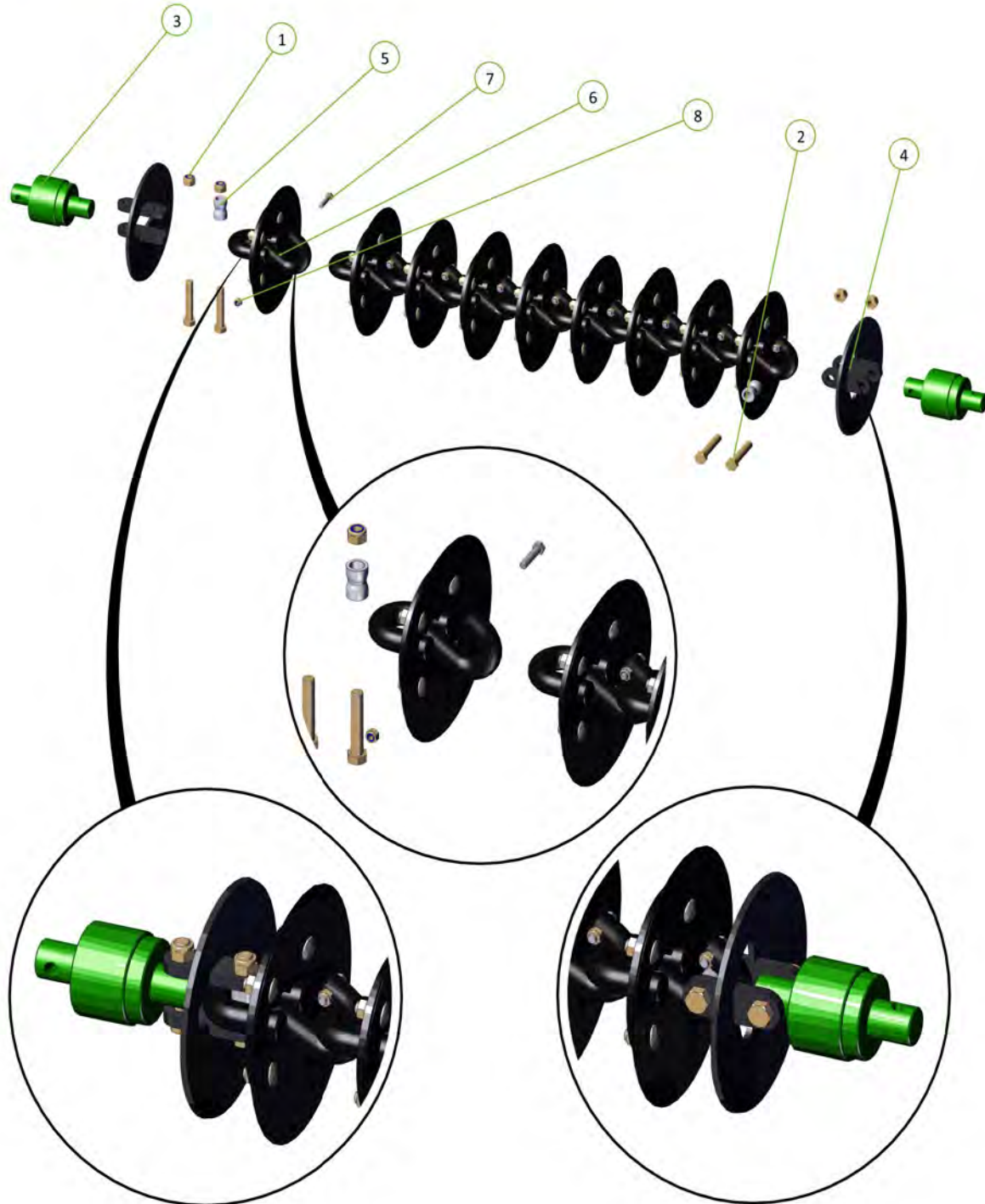

Item No.	Description	Number
1	Nyloc Nut M20	0221-NYL20
2	M20 x 110 Class 10.9 ZP Short Thread Bolt	0211-20110ST
3	20mm Bolt Swivel Unit	0802-PCHB55
4	Tie Plate Disc 20mm	0802-DCTP-20
5	Disc Chain Spacer	0801-253755
6	W36/25 Chain Link	0803-W36



W36 Disc Chain - cut a disc chain link from the end of the disc chain

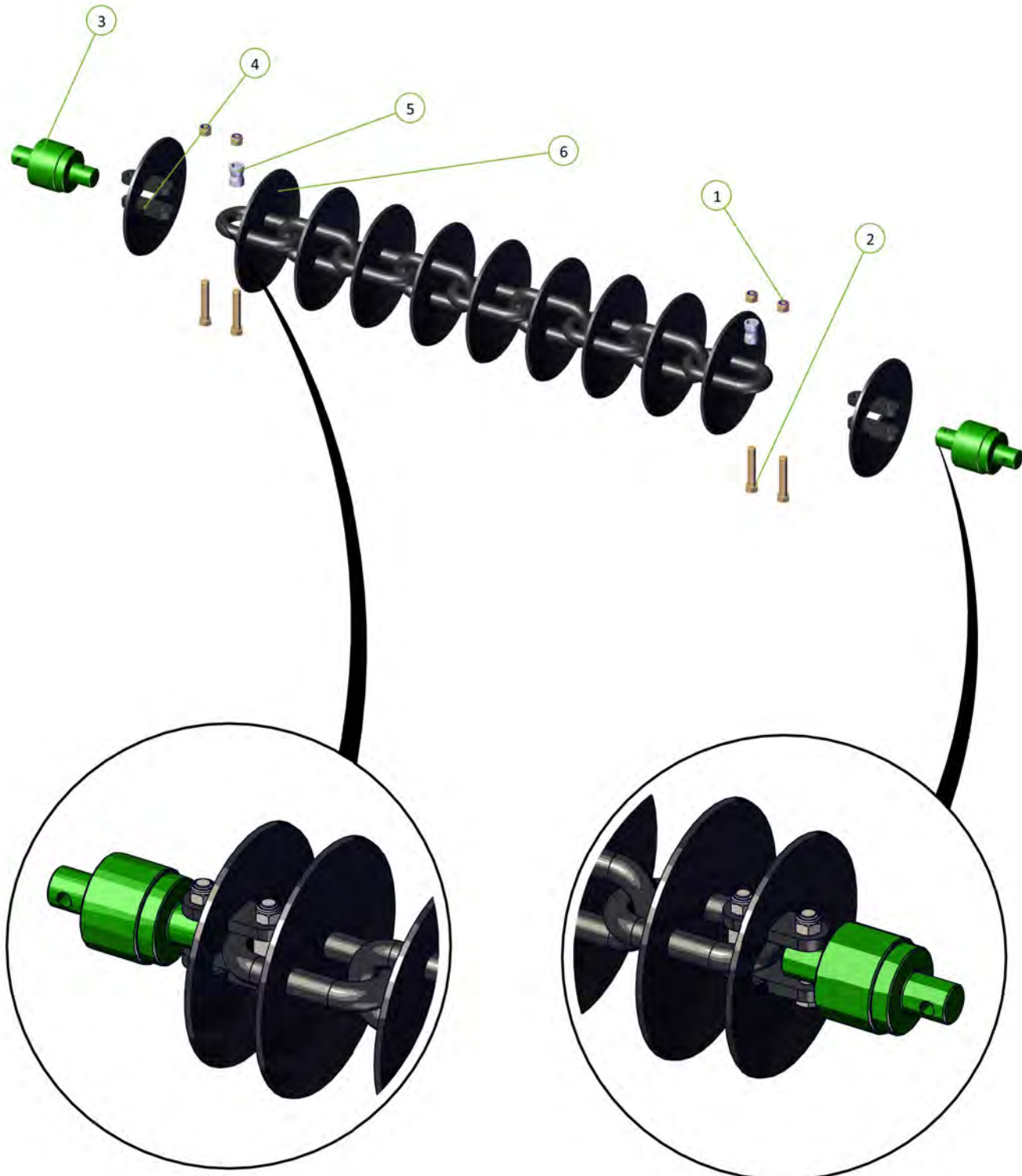

Item No.	Description	Number
1	Nyloc Nut M20	0221-NYL20
2	M20 x 110 Class 10.9 ZP Short Thread Bolt	0211-20110ST
3	20mm Bolt Swivel Unit	0802-PCHB55
4	Tie Plate For 20mm Bolt	0800-83.2
5	Disc Chain Spacer	0801-253755
6	10 Spike Disc Chain 49/27/5	0803-SD49



Spiked Disc Chain - cut a disc chain link from the end of the disc chain

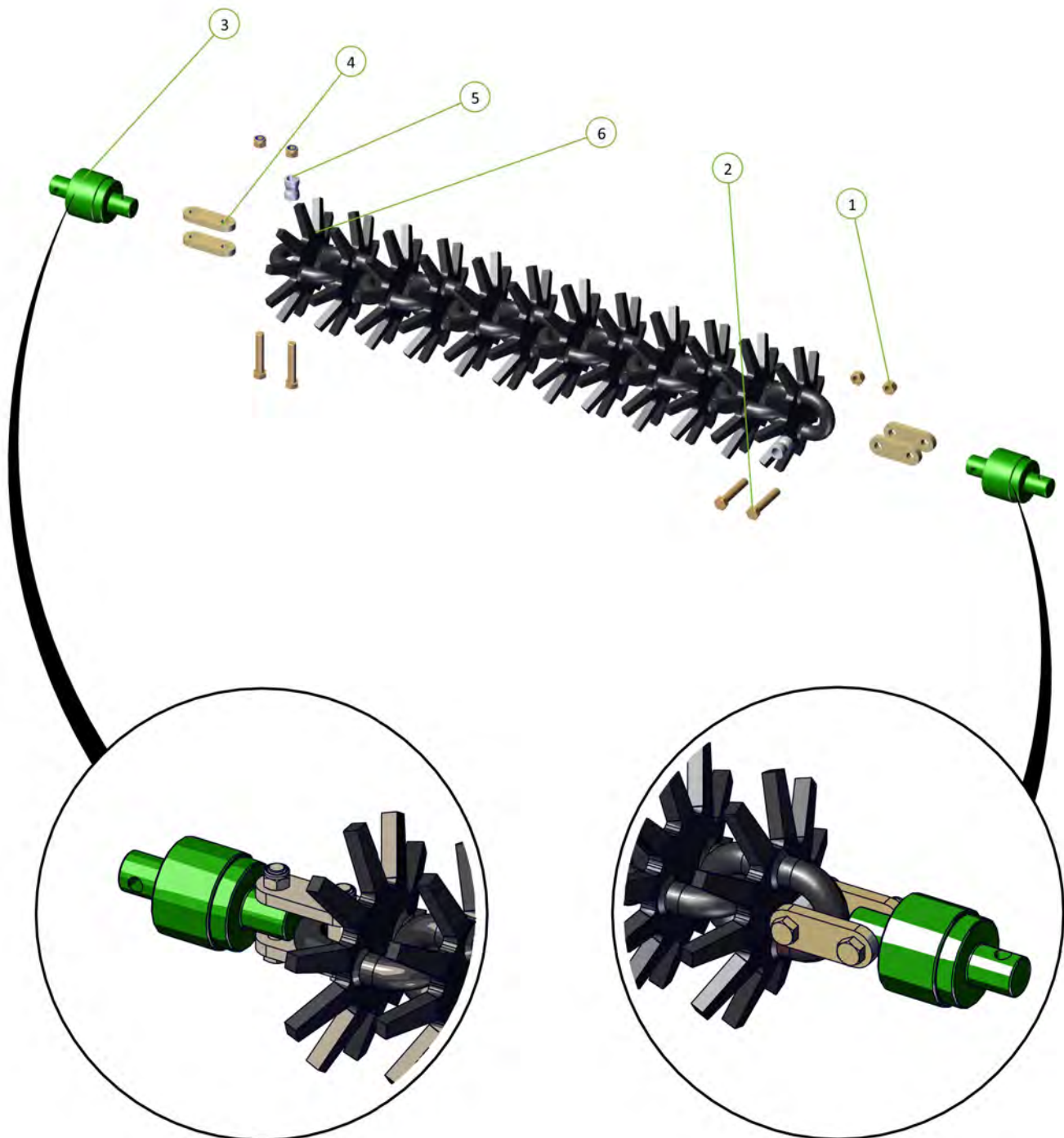



Section 6 - Specifications

Wiring Diagram

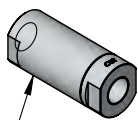

0343-924001261
1/2" BSPP 60 micron inline filter
max flow 60L/M & 5000psi max pressure

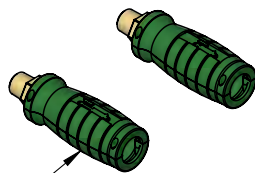

0325-HG-PT24E25R
Green 1/2" NPT Hydra
Grip Pair (Extend /Ret)

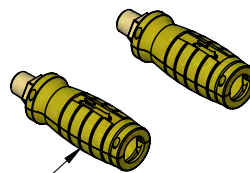

0325-HG-PT25E25R
Yellow 1/2" NPT Hydra
Grip Pair (Extend /Ret)

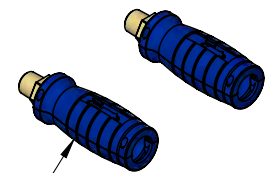

0325-HG-PT20E20R
Blue 1/2" NPT Hydra
Grip Pair (Extend /Ret)



0323-S71-0812
1/2"BSPP O Ring Male - 3/4"JIC Female
Adaptor



0323-S74-0812
1/2"BSPP O Ring Male - 3/4"JIC Male
Adaptor



0323-S15-1212
3/4"JIC Male - 3/4"JIC Female
90° Elbow



0323-S91-1212
3/4"JIC Male - 3/4"UNO Male
90° Elbow



0323-S90-1212
3/4"JIC Male - 3/4"UNO Male
Adaptor



0324-S19-121212
3/4"JIC Male
Tee



0324-S67-121212
3/4"JIC Male - 3/4"JIC Female - 3/4"JIC Male
Tee



0323-S88-1212
3/4"JIC Male - 3/4"UNO Male
45° Elbow



0324-S92-121212
3/4"JIC Male - 3/4"JIC Female - 3/4"UNO
Male Tee



0324-S68-121212
3/4"JIC Male - 3/4"JIC Female - 3/4"JIC
Female Tee



0325-R91-08M
1/2" BSPP
Quick Release Ball Coupling



0323-S12-1212
3/4"JIC Male - 3/4"UNO Male
Extended 90° Elbow



Part Number

Description

For Machines Built:

Revision

Hydraulic Fittings Parts Information

B

Wiring Diagram

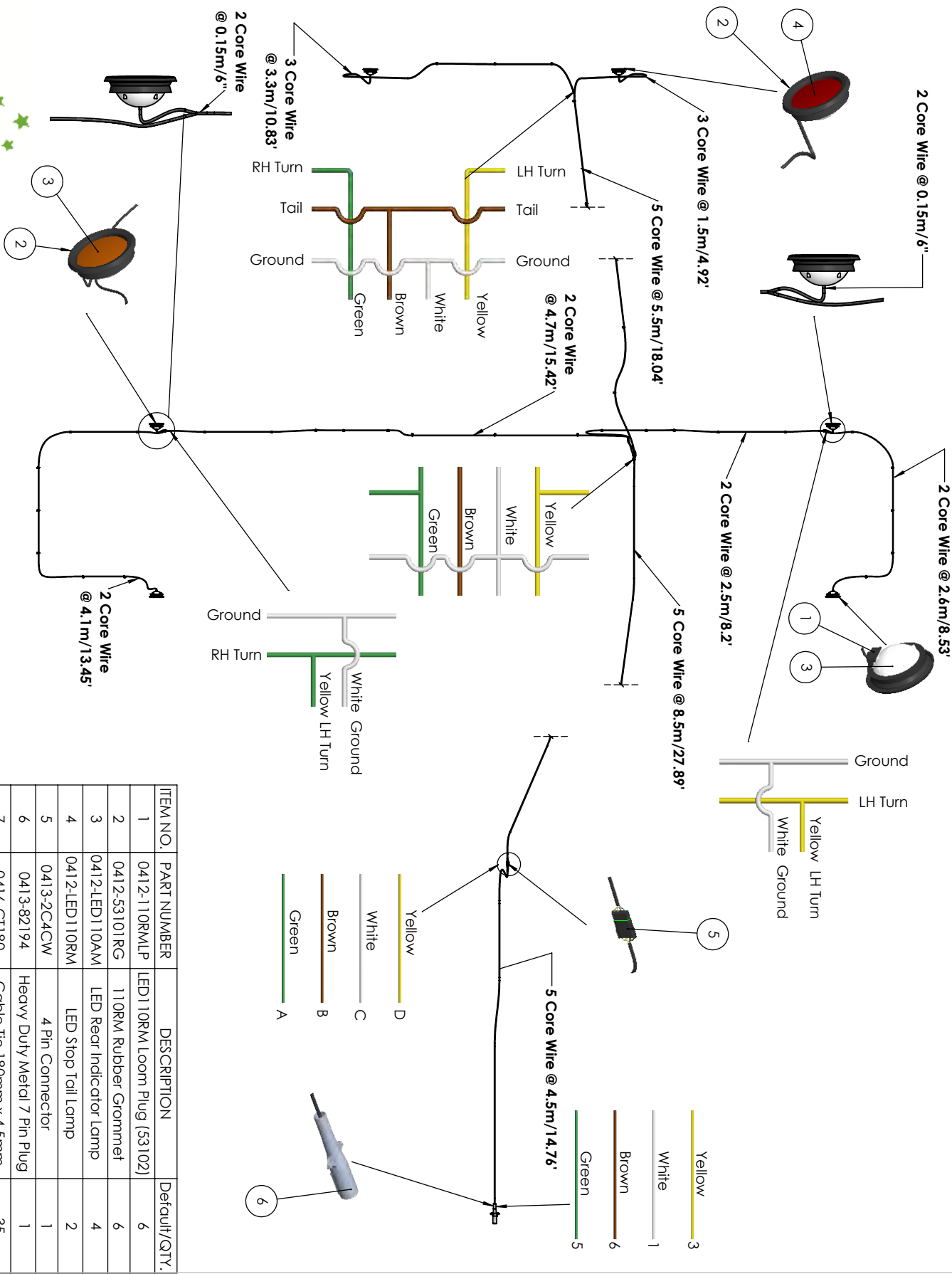

Part Number
1602-USLK46-2

Description
46' Gen 2 - US Light Kit

ITEM NO.	PART NUMBER	DESCRIPTION	Default/Qty.
1	0412-110RM1P	LED 110RM Loom Plug (S3102)	6
2	0412-53101RG	110RM Rubber Grommet	6
3	0412-LED110AM	LED Rear Indicator Lamp	4
4	0412-LED110RM	LED Stop Tail Lamp	2
5	0413-2C4CW	4 Pin Connector	1
6	0413-82194	Heavy Duty Metal 7 Pin Plug	1
7	0416-CT180	Cable Tie 180mm x 4.5mm	35

For Machines Built:

Revision
A-0

Mounting Swivels

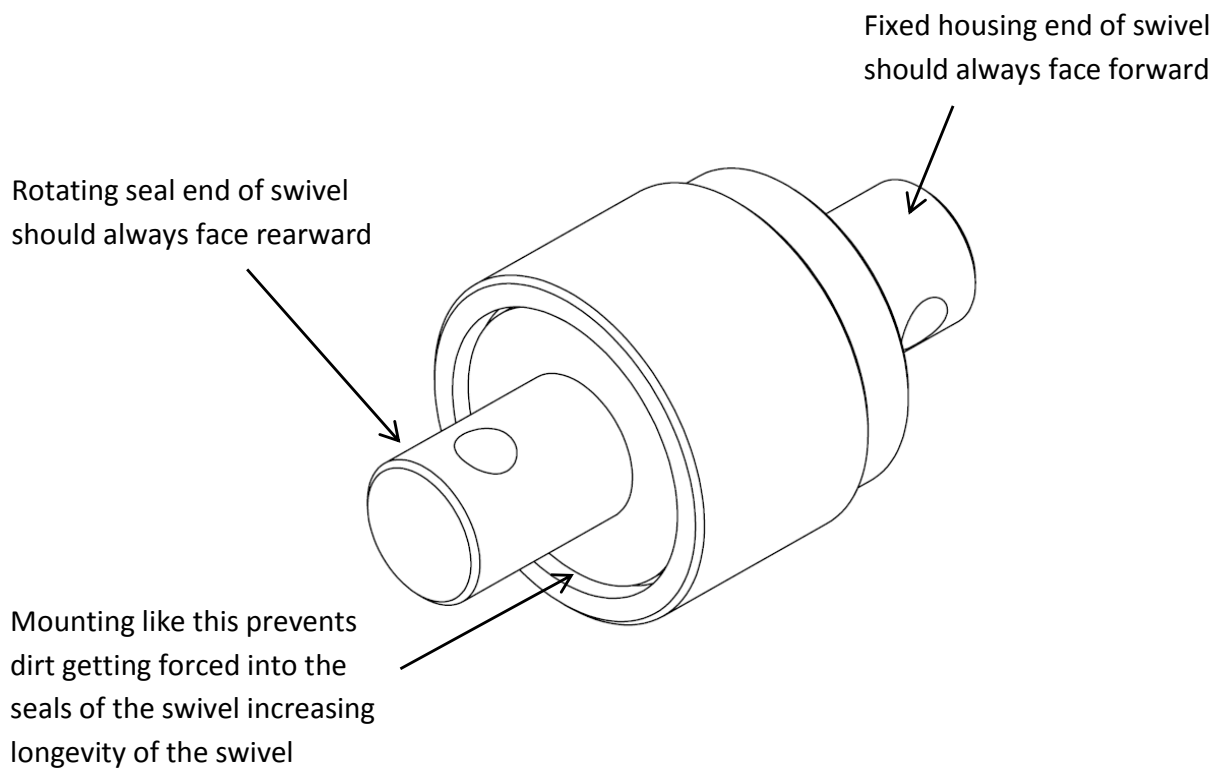

For Example

Swivels attached to the leading ends of the chains should have the rotating seal end attached to the chain like shown

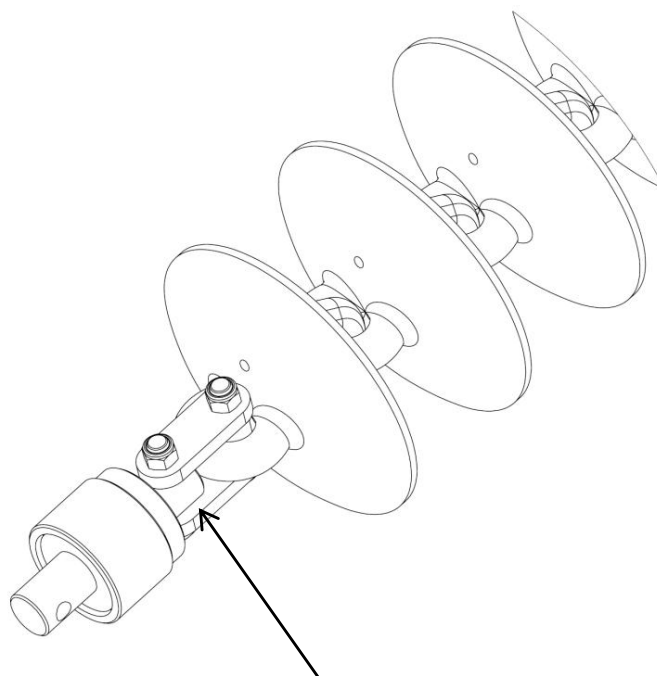
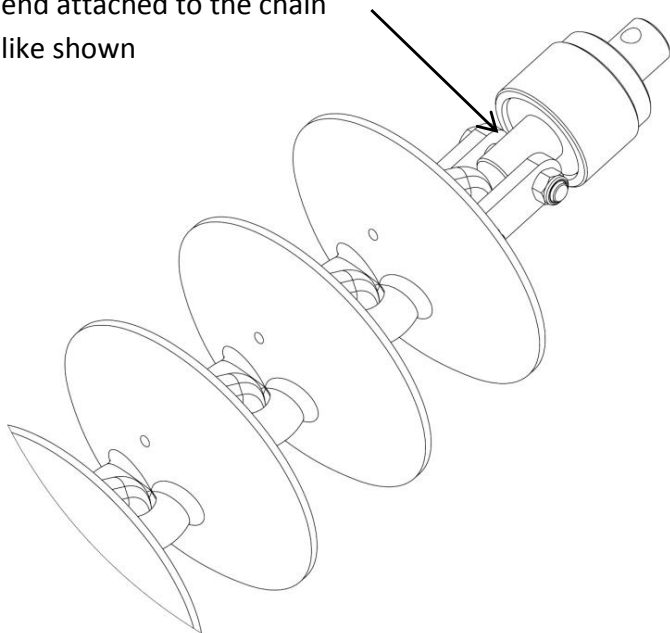

Swivels attached to the trailing ends of the chains should have the fixed housing end attached to the chain like shown

Operating speeds

Recommended operating speeds in normal conditions with all chain types	
Operating and working speeds	6-10 Mph / 10-16 kmph
Transporting / towing speed	15 Mph / 25 kmph

Tyre pressure

Tyre size	Ply	PSI	KPA
16.5L x 16.1	14	36	250
H40 x 14.5-19	26	60	410
11L - 15	10	44	300
15.5/80/24	16	58	400
16.5/85/24	16	55	380
550/60/22.5	16	40	280
400/60/22.5	16	50	350
12.5/80/18	14	85	590
15.0/70/18	14	71	490

4614 specifications

Model	4614
Working width	45'9/13.97m
Transport width	12'9/3.90m
Transport height	12'10/3.93m
Transport length	55'11/17.06m

Disc Chain Lengths

Model		Length	CL2	CL1	K4	W36	R300	SD49	Prickle chain
			CL2 disc chain also requires CL1 disc chain						
4614	Front right	28.15' / 8.58m	CL2 - 38 CL1 - 2	53	54	50	69	69	95
	Front left	28.15' / 8.58m	CL2 - 38 CL1 - 2	53	54	50	69	69	95
	Rear right	36.99' / 10.97m	CL2 - 40 CL1 - 15	67	69	64	88	88	122
	Rear left	29.23' / 8.91m	CL2 - 40 CL1 - 2	54	56	52	71	71	99
	Modules front	11.02' / 3.36m	CL2 - 13 CL1 - 3	20	21	20	27	27	37
	Modules rear	10.99' / 3.35m	CL2 - 14 CL1 - 2	20	21	20	27	27	37

For correct chain tension, chain links may need to be removed from the end of the chain as follows:

CL2 Disc Chain - unhook disc chain link/s from end of the disc chain

K4 Disc Chain - unhook disc chain link/s from end of the disc chain

CL1 Disc Chain - unhook disc chain link/s from end of the disc chain

SD49 Disc Chain - cut a disc chain link from the end of the disc chain

W36 Disc Chain - cut a disc chain link from the end of the disc chain

Prickle Chain - cut a prickle chain link from the end of the prickle chain

R300 Disc Chain - cut a disc chain link from the end of the disc chain

Scan the following QR code to open the removing a welded disc chain video





Section 7 - Operation

Basic Operation

Unfolding:

1. Walk around and inspect the machine.
 - a. Check that chains are not hooked on framework
 - b. Check swivel units are in place and not broken
 - c. Check that height adjusting chains have not fallen out of their slotted plates during transport.
 - d. Ensure front lift cylinder depth stops are fully engaged on cylinder shaft.
2. Lower front A frame to working height.
3. Unfold wings holding the hydraulic lever until both the main center cylinder pins have centered in their slots. (If chain pulls tight during unfold, stop and inspect if chain is hooked)
4. Lower rear tail by holding hydraulic lever until tail and modules are completely lowered to working position.
5. Walk around and check that all chain links are straight and that working height of all swivels is correct for field conditions. Adjust if necessary.
6. Move off with all chains in working position. If necessary it is acceptable to raise front A frame to transport height. This will lift the front chains off the ground and reduce the load on the tractor. Lower the front A frame once moving satisfactorily.

Folding:

1. Lower the front A frame at working height. (This is important to ensure that all chains locate correctly in their transport rests).
2. Raise the Rear Tail and modules by holding the hydraulic lever until they come to a complete stop.
3. Fold the wings. They should move as follows; main center cylinders will retract, one or both, until the wings stand vertically. The left outer wing then the right outer wing will fold down.
4. Raise front A frame to transport height.

Setting for correct chain tension

Wings

Use the spanner supplied. Loosen the lock nut adjacent to the tensioner assembly body. Turn the tension bolt clockwise to compress the coil spring. Correct tension is achieved when spring retains its set length when operator rolls the chain fore and aft on the ground. Retighten the lock nut.

Spring Compression Length

Model	inches	mm
4614	12.4	315

When less than 4" (100mm) of thread remains visible on the adjustor bolt then a link must be removed from the chain.

Chain Tension - Modules

1. Loosen the lock nut on the draw bolt.
2. Tighten the adjusting nut clockwise until the outer face of the spring retaining washer is pushed with the body of the module tensioning unit.
3. Retighten the lock nut.
4. If more than 8" (200mm) of thread is exposed then a link should be removed to maintain correct adjustment.



Importance of chain tension

Operational

Chain tension is critical to achieve a smooth and level seedbed. A correctly tensioned, monitored and maintained chain will deliver the results you need. Incorrect chain tension can lead to:

- Uneven results across the cut width of the machine
- Uneven weed control
- Unsatisfactory incorporation
- Ineffective levelling
- Accelerated or premature chain link wear (not covered by warranty)
- Chains failing to engage with transport locator's when folded
- Machine damage when folding or unfolding
- Uneven field surface with ridges and furrows being created.

A correctly adjusted machine will not cause this problem.

Correct Chain Height Adjustment

To adjust the swivel height at the wings, relocate one of the spacers either above or below the fixed mounting tube. Each Dropleg has four pairs of 0.98" / 25mm cast spacers. The most common set up is to have two pairs of cast spacers on the bottom and two pairs of cast spacers on the top. Below is the process to adjust the Dropleg height.

1	Loosen chain tension completely
2	Undo 2 x M10 bolts from corresponding spacer set and take the two halves off of the drop leg tube
3	Replace it in the selected position after raising or lowering the drop leg
4	Reinstall the M10 bolts and re-tension the chain

It is possible to install all spacers either above or below the mounting tube giving a maximum of 4" (100mm) of adjustment.

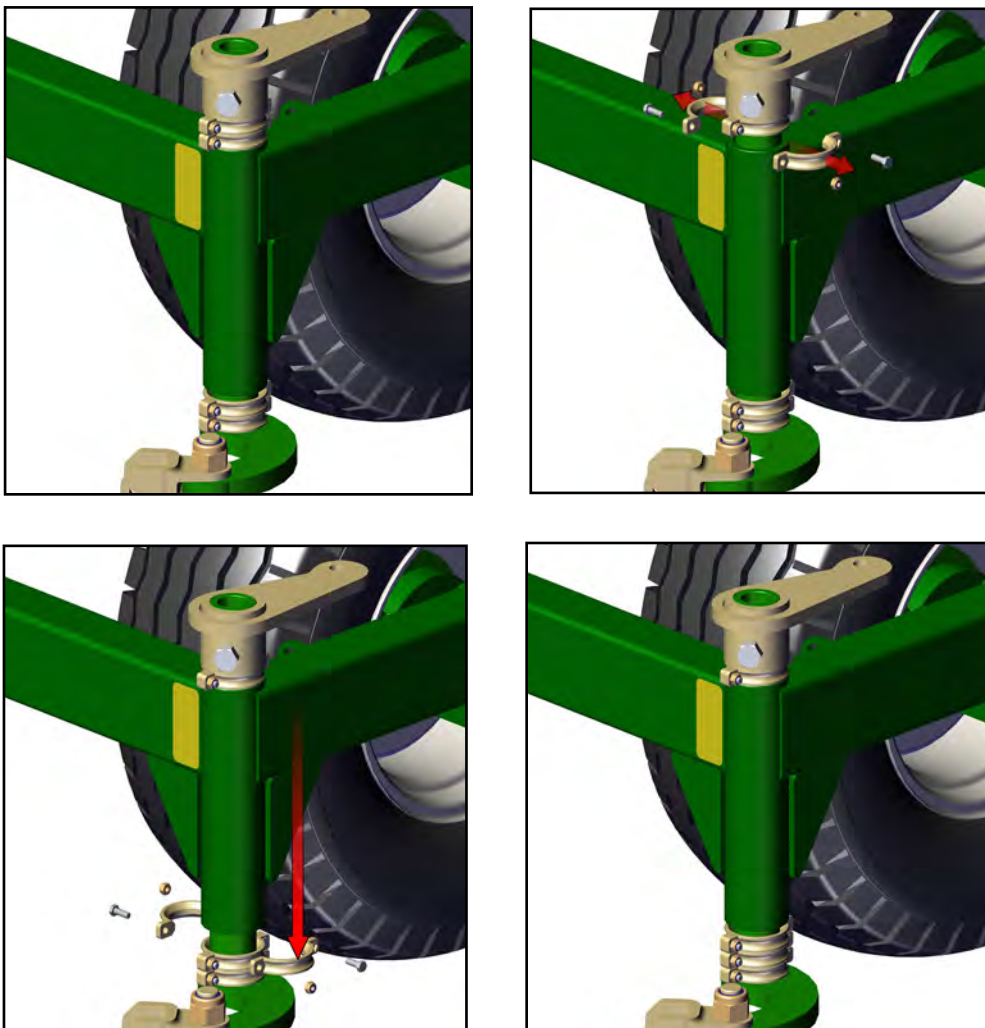



Notes



Phone +61 8 8667 2253
Email sales@kellytillage.com
kellytillage.com

Booleroo (Head Office)
684 Kelly Road,
Booleroo Centre SA 5482

Adelaide Office
28 Greenhill Road,
Wayville SA 5034

