



Diamond Chain Harrow Assembly and Parts Manual

Model 30

Revised E January 2017

Kelly Engineering
PO Box 100
Boileroo Centre SA 5482
Australia

Phone: + 61 8 8667 2253

Fax: + 61 8 8667 2250

Email: office@kellyengineering.com.au

Website (US): www.kellyharrows.com

Website (Australia): www.kellyengineering.com.au



Thank you for choosing a Kelly Engineering product

We trust that you find the following manual clear and easy to follow. If you should require additional customer support or assistance, please do not hesitate to contact us.

Spare parts can be purchased, as required, through your local dealer or by contacting Kelly Engineering Australia or in the United States, Hood & Company.

Kelly Engineering welcomes feedback. Should you have any difficulties that you wish to raise, suggestions for improvement or modifications that you feel would enhance our products we look forward to hearing from you.

Australia

Kelly Engineering

PO Box 100

Booleroo Centre SA 5482

Phone: + 61 8 8667 2253

Fax: + 61 8 8667 2250

Email: sales@kellyengineering.com.au

Spare Parts: parts@kellyengineering.com.au

Website: www.kellyengineering.com.au

United States

Kelly Engineering

200 W. Douglas, Suite 200

Wichita KS 67202

Phone: 316 265 7308

Mobile: 316 304 6178

Email: waynerosenbaum@kellyharrows.com

Website: www.kellyharrows.com

Spare Parts

Hood & Company Inc

Springfield MO

Phone: 417 865 2100

Fax: 417 865 2105

Email: hoodco@hoodco.com

Contents

	Page no
Section 1: Unpacking	4
Section 2: Parts	7
Section 3: Diagrams and charts	49
Overview	50
Chains	51
Hydraulics	52
Hydraulic fitting identification	53
Hydraulic layout	54-55
Hydraulic detail	56-60
Hose layout	61
Electrical layout	62-63
Electrical detail	64-65
Mounting swivels	66
Fitting cast link retaining pins	67
Specifications	68-69
Section 4: Operation	70
Basic operation and chain tension	71
Module and chain tension	72
Correct working height	73
Assembly Updates	74
Front cylinder depth stop	74
Hydraulic valve block	75
Rear light brackets	76
Brake disc collar (Revision B)	77
Correct hose attachment	78
CL2 chain configuration - All machine	79
CL2 chain configuration - 30ft	80
Chain tensioners on rear tail	81-83
CL2 disc change procedure	84-86

Section 1

Unpacking

Unpacking

We recommend the use of suitable lifting equipment for unloading and assembly



- Before unloading any loads please inspect exterior for damage



CAUTION

Take care when opening doors as load may have shifted or restraints may have broken.

- Remove boxes from doorway of container one at a time using a forklift truck. Each box weighs approximately 2600 lbs (1200kg)
- Check strapping on each bundle before attempting to remove
- Attach chains to the packing frame using shackles and using suitable equipment (eg. fork-lift or tractor) drag framework bundles out of container. To move bundles away from front of container lift from side with forklift. Do not lift under angle iron frame, lift only under centre frame. Each bundle weighs approximately 7000 lb (3200 kg).

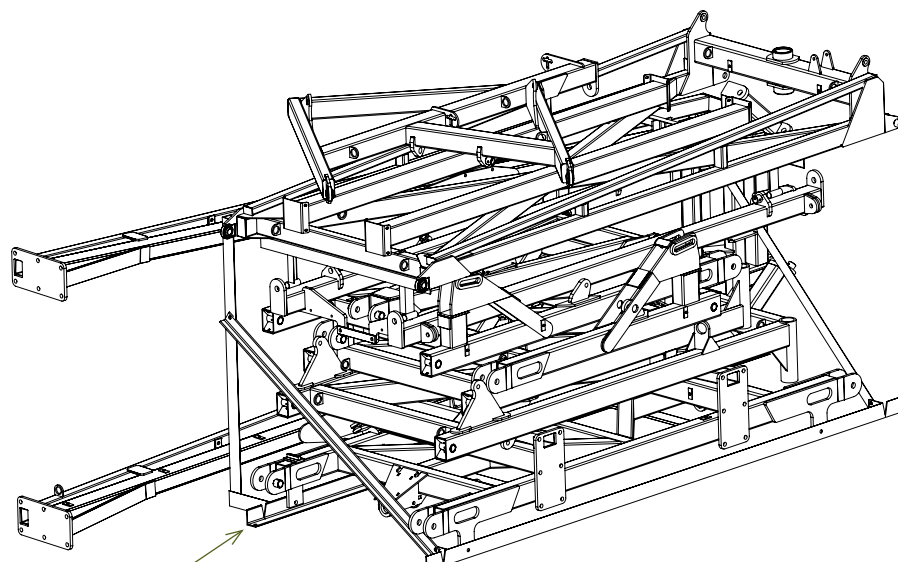

Connect chains to these points

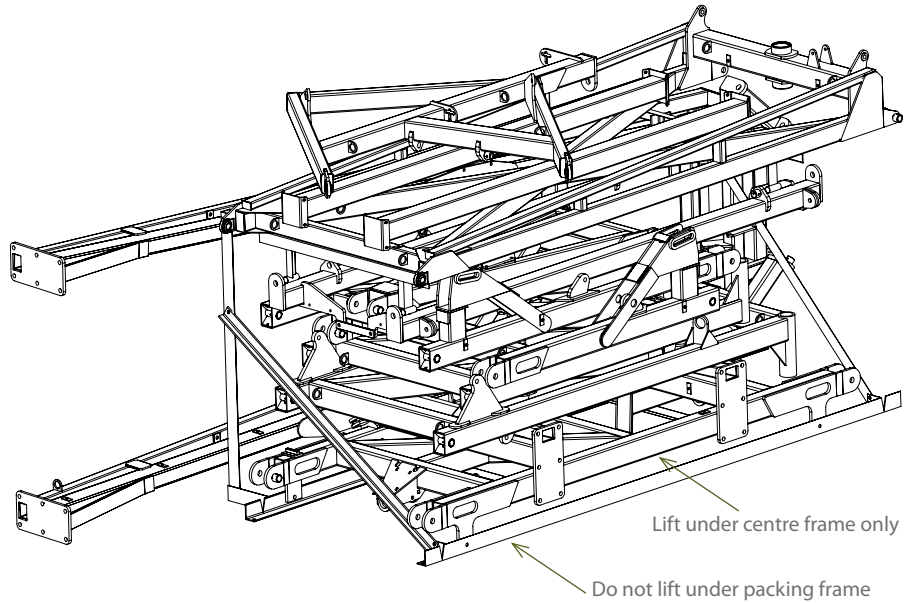

CAUTION

Before cutting straps attach slings or chains and take the weight of the frames to avoid them slipping or falling and causing injury.



CAUTION

Wear eye and hand protection when cutting straps. Sharp edges are exposed as straps separate and may cause injury.



CAUTION

To avoid falling or moving components, before cutting straps attach slings or chains to individual pieces and only cut the straps holding the piece to be lifted.

- Remove boxes from rear of container one at a time using a forklift truck. Each box weighs approximately 2600 lbs (1200 kg)
- Cut straps holding bundles and separate parts and place in assembly area
- Once all parts have been identified machines are ready for assembly
- Identify parts for each machine by serial no. or description and separate. Open parts box and check that all parts are accounted for against checklist
- Read assembly instructions before proceeding.

Section 2

Parts

PART NUMBER	DESCRIPTION	QTY.
0830-01	30' Centre Frame	1
0733-SH27596880	2.75' r 6 Tonne 8 on 8' PCD hub complete	2
0211-20150	M20 x 150 8.8 zp Bolt	2
0221-NYL20	M20 Nyloc Nut	2

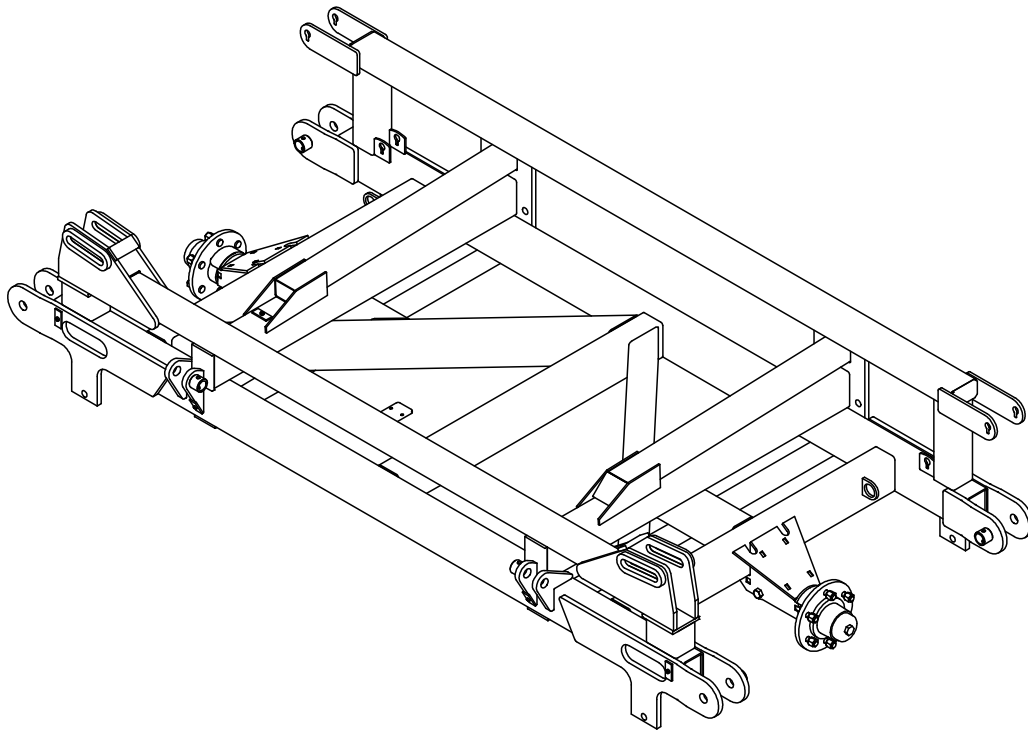
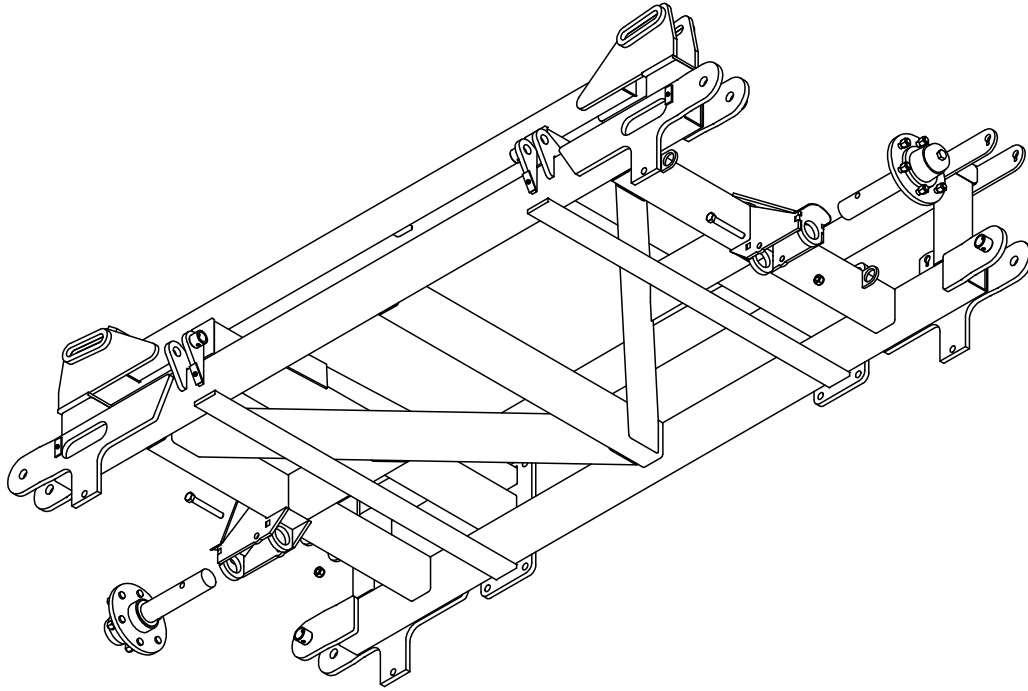

TRAVEL

PART NUMBER	DESCRIPTION	QTY.
0830-06	30" RH Wing Frame	1
0181-GN1-845	Grease Nipple 1/8" BSP 45 Deg	2
0801-10-08-235	PCH Wing Pivot Pin	2
0211-1265	M12 x 65 8.8 zp Bolt	2
0221-NYL12	M12 Nyloc Nut	2
0113-MB 3550DX	35 ID x 50mm DX Bush	4
0261-PINC1363	Cotter Pin M13 X 63mm	2

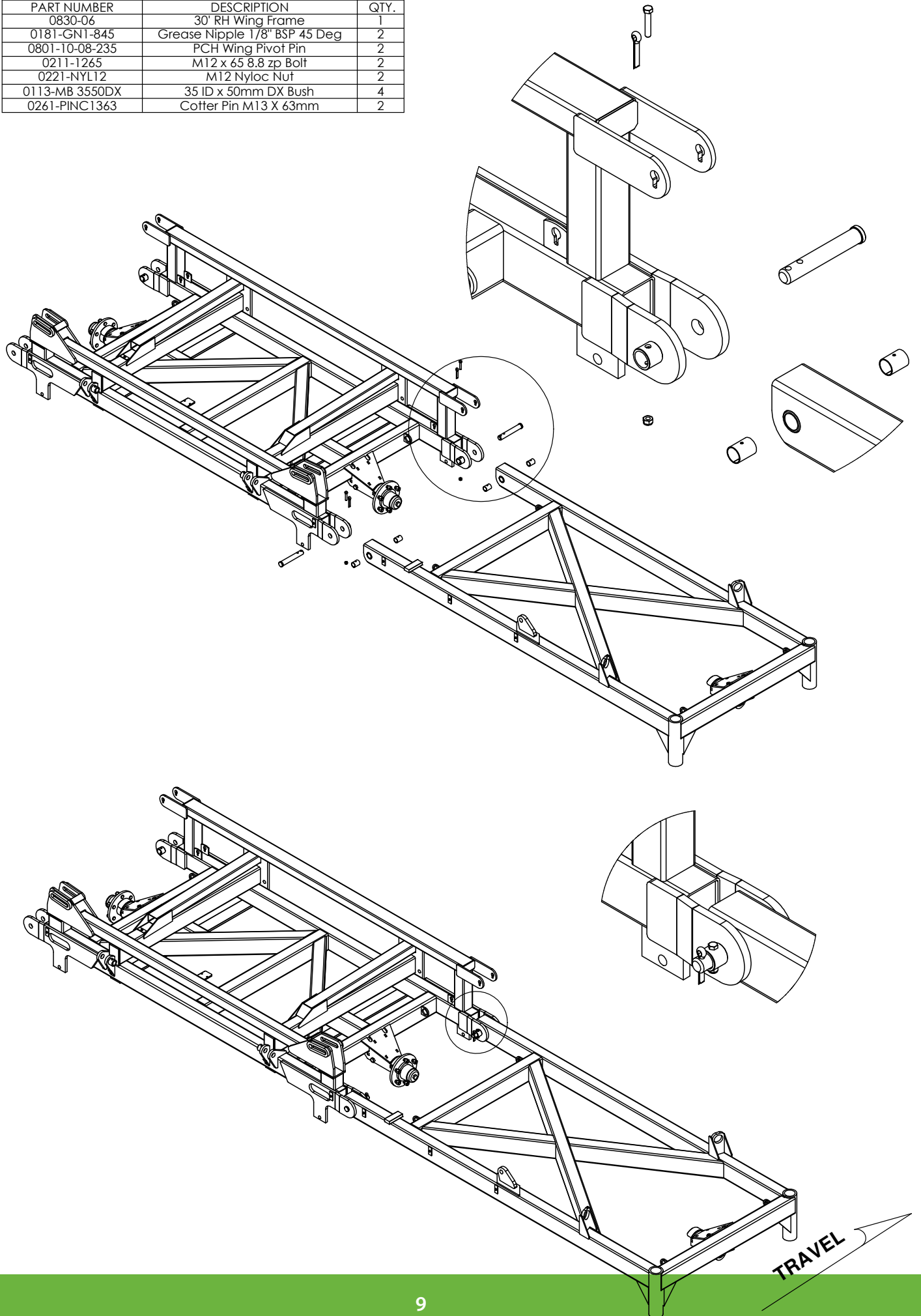

PART NUMBER	DESCRIPTION	QTY.
0181-GN1-845	Grease Nipple 1/8" BSP 45 Deg	2
0801-10-08-235	PCH Wing Pivot Pin	2
0113-MB 3550DX	35 ID x 50mm DX Bush	4
0830-07	30° RH Wing Frame	1
0211-1265	M12 x 65 8.8 zp Bolt	2
0221-NYL12	M12 Nyloc Nut	2
0261-PINC1363	Cotter Pin M13 X 63mm	2

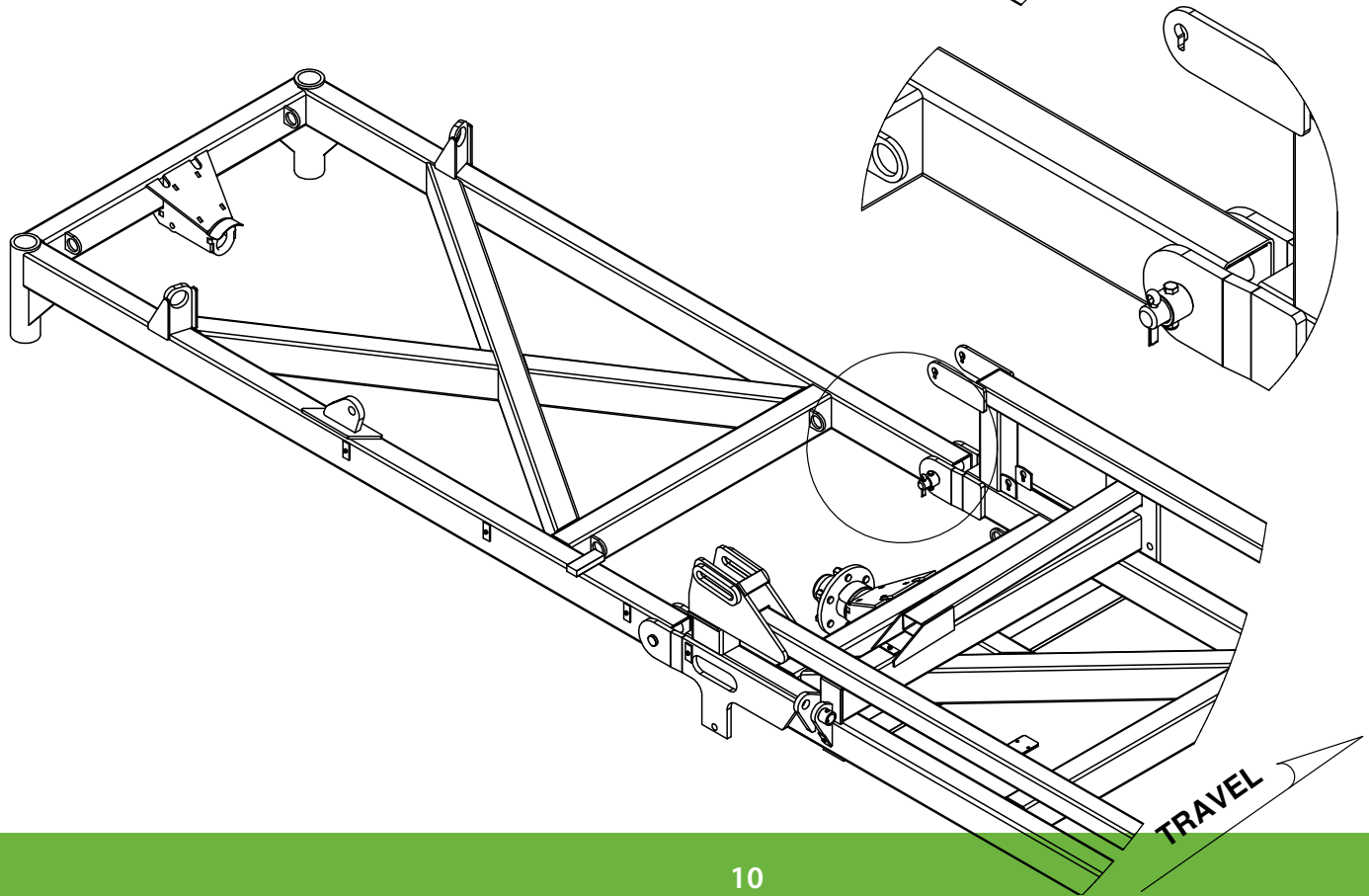
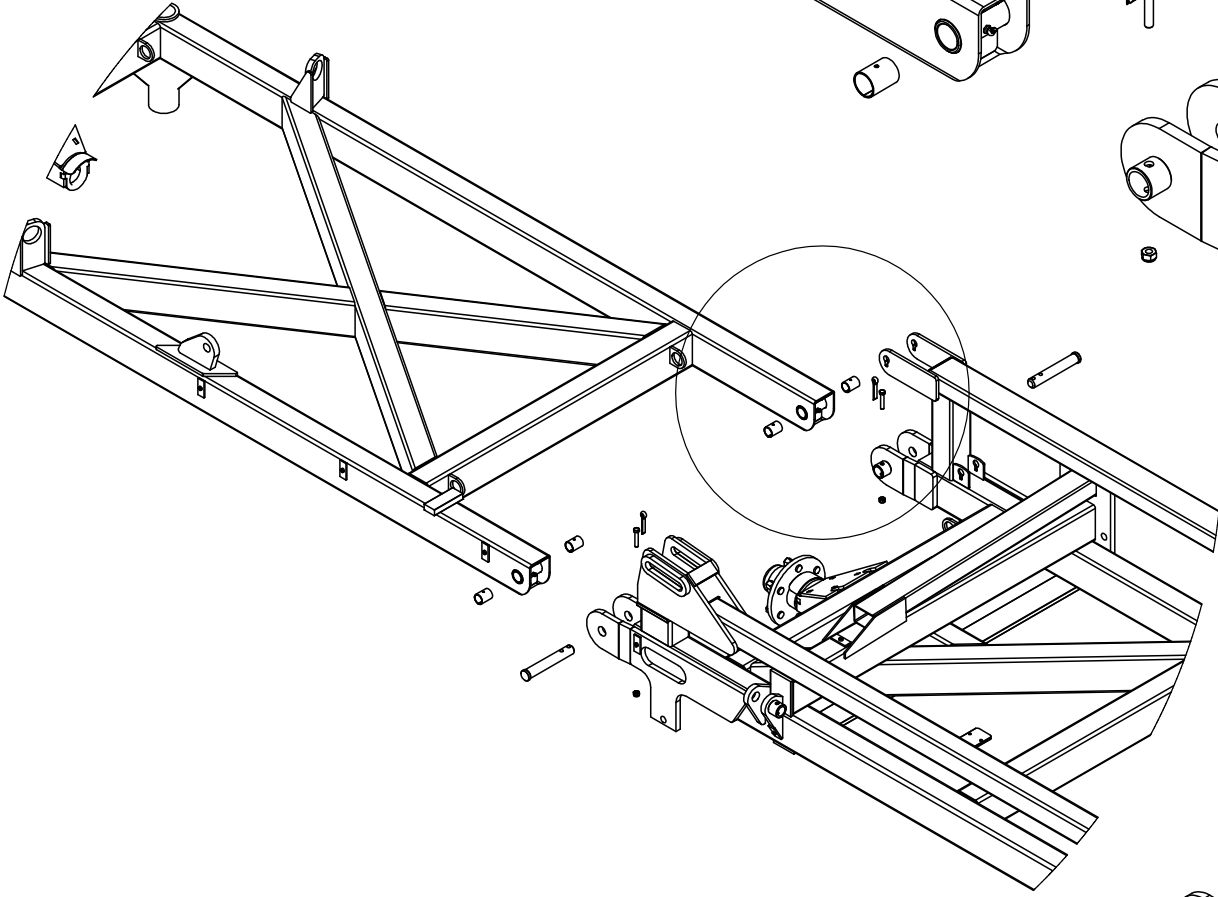
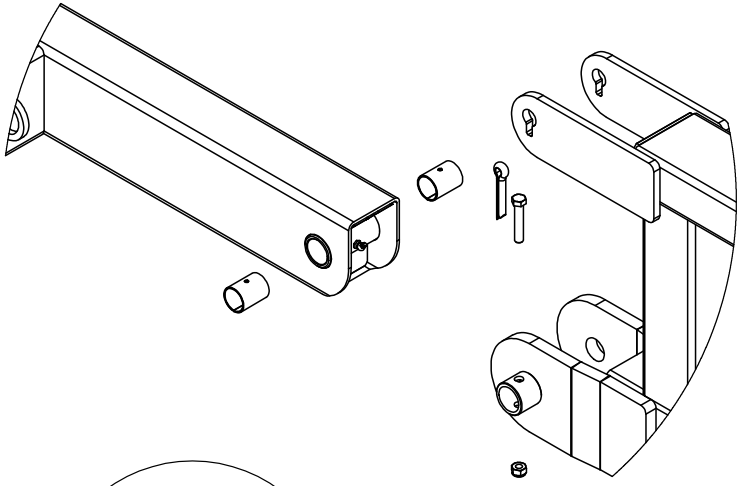

PART NUMBER	DESCRIPTION	QTY.
0733-SH27596880	2.75' r 6 Tonne 8 on 8' PCD hub complete	1
0211-20150	M20 x 150 8.8 zp Bolt	1
0221-NYL20	M20 Nyloc Nut	1

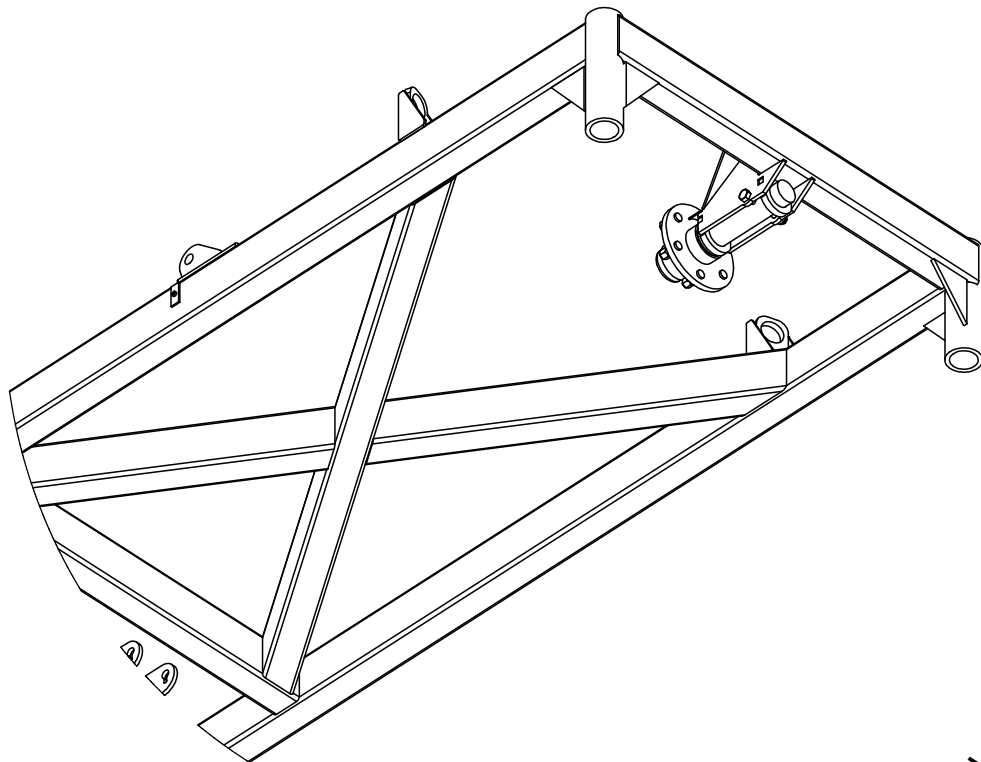
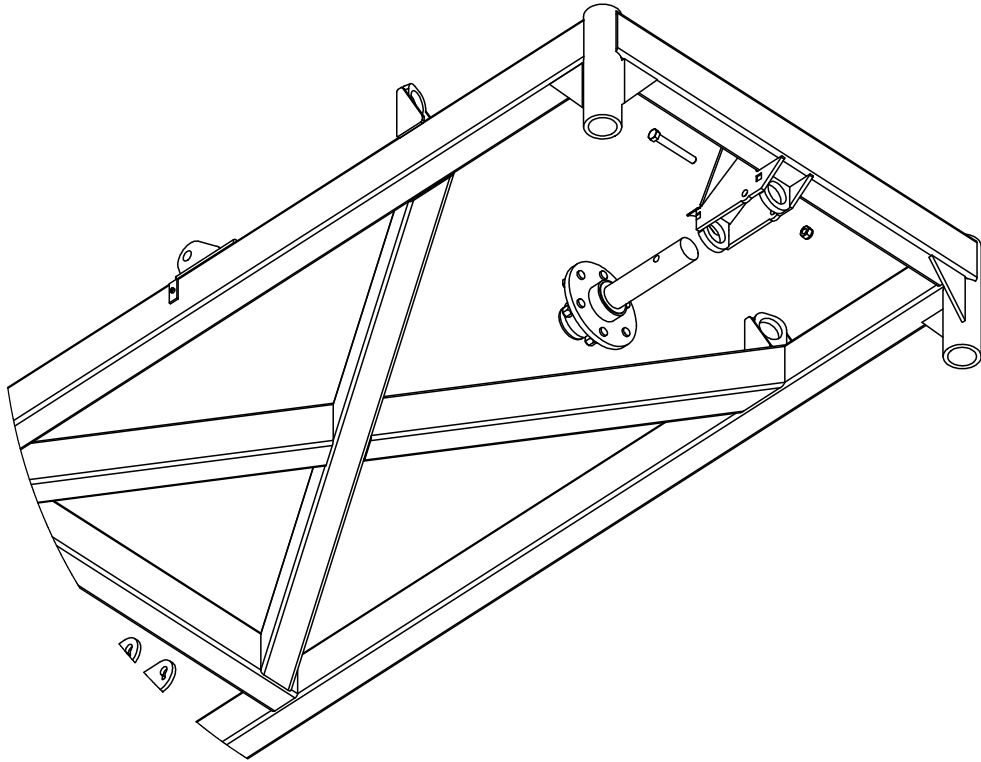

TRAVEL

PART NUMBER	DESCRIPTION	QTY.
0733-SH27596880	2.75' r 6 Tonne 8 on 8' PCD hub complete	1
0211-20150	M20 x 150 8.8 zp Bolt	1
0221-NYL20	M20 Nyloc Nut	1

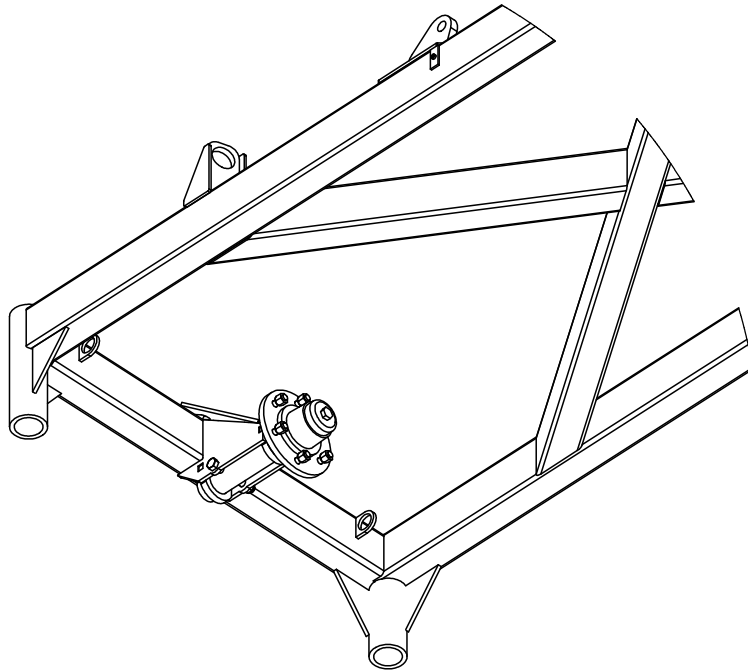
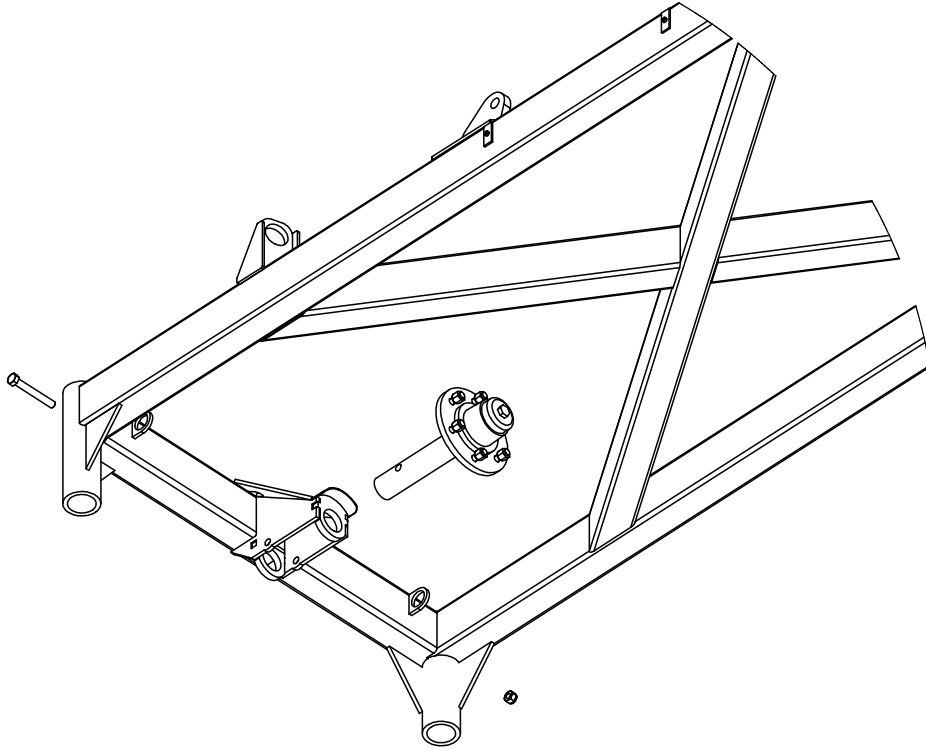

TRAVEL

PART NUMBER	DESCRIPTION	QTY.
0311-4305T	4' x 30" Hydraulic Cylinder	1
0801-44102956-1	Cylinder Pin 1 1/4" x 220mm 4140	1
0801-44102956-2	Cylinder Pin 1 1/4" x 116mm	1
0232-11-4 FW	Washer Flat 1 1/4"	2
0801-KE012	S Locking Pin Clip 5mm	3

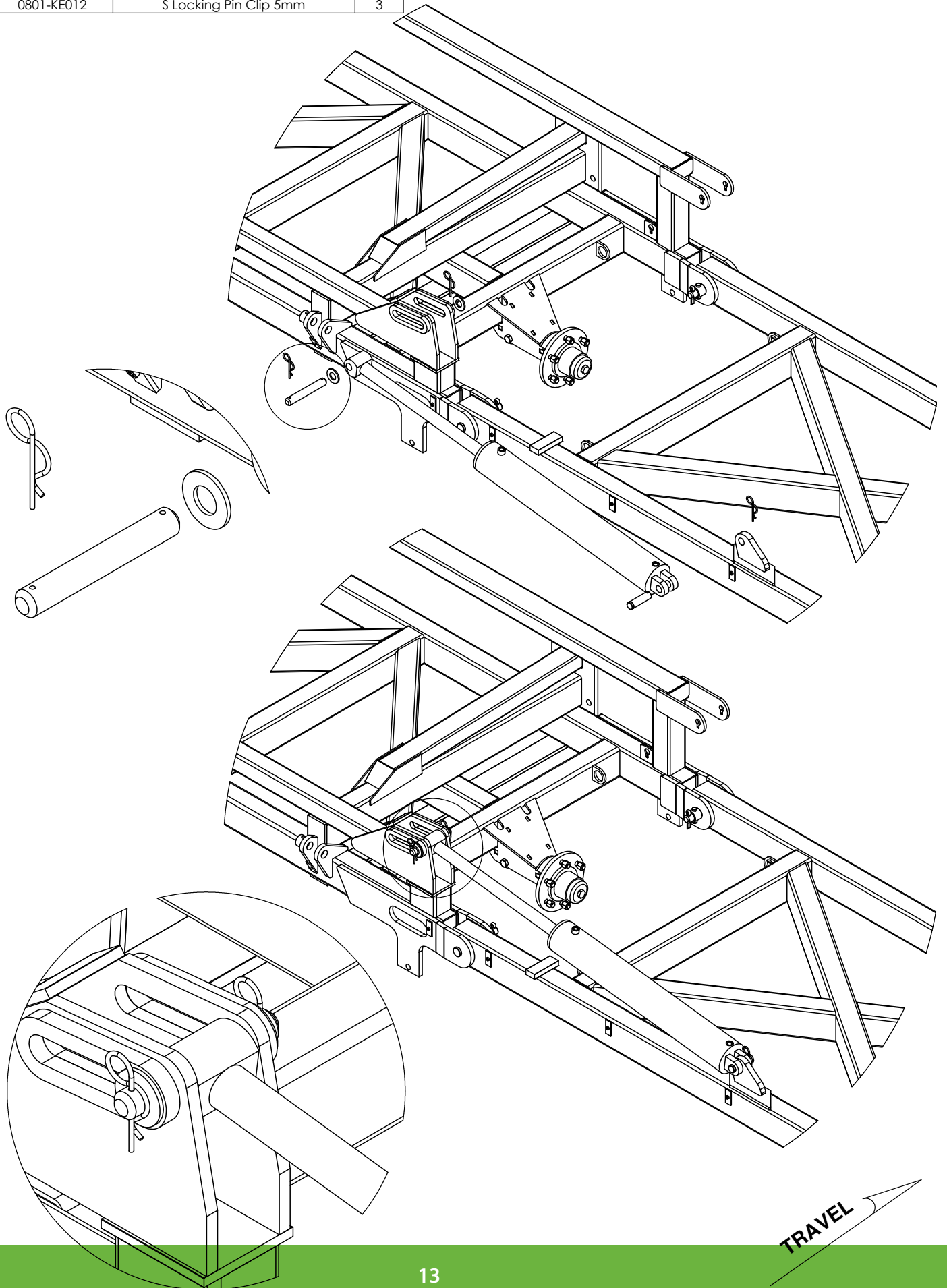

PART NUMBER	DESCRIPTION	QTY.
0311-4305T	4' x30" Hydraulic Cylinder	1
0801-44102956-1	Cylinder Pin 1 1/4" x 220mm 4140	1
0801-44102956-2	Cylinder Pin 1 1/4" x 116mm	1
0232-11-4 FW	Washer Flat 1 1/4"	2
0801-KE012	S Locking Pin Clip 5mm	3

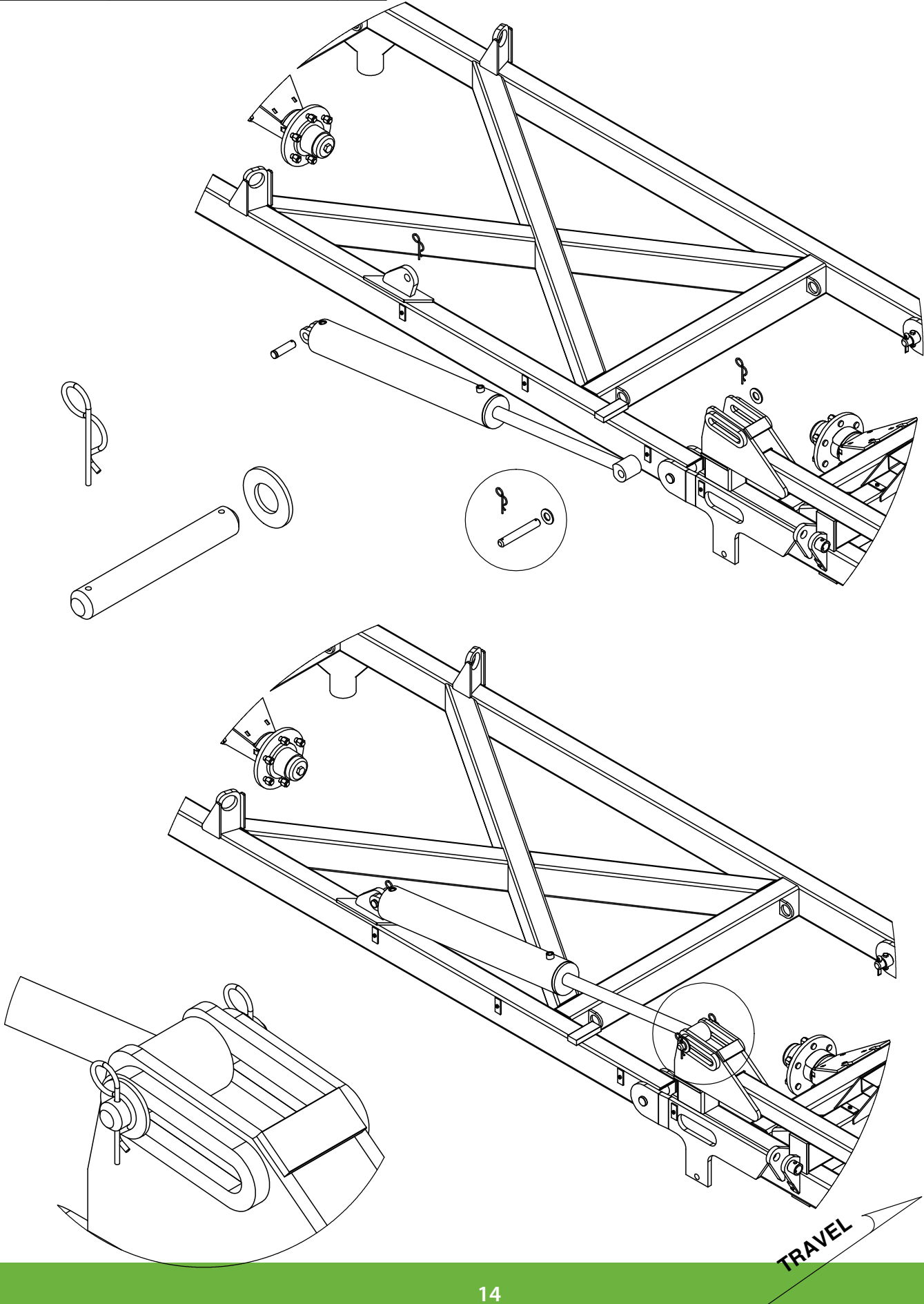

PART NUMBER	DESCRIPTION	QTY.
0810-28-30	30' Front Module	1

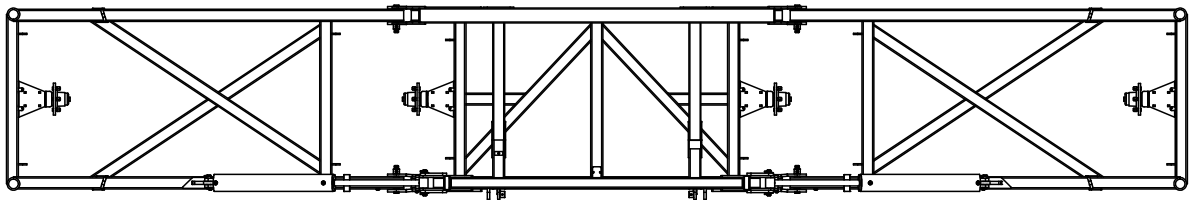
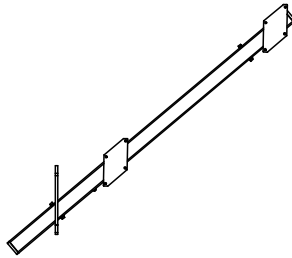
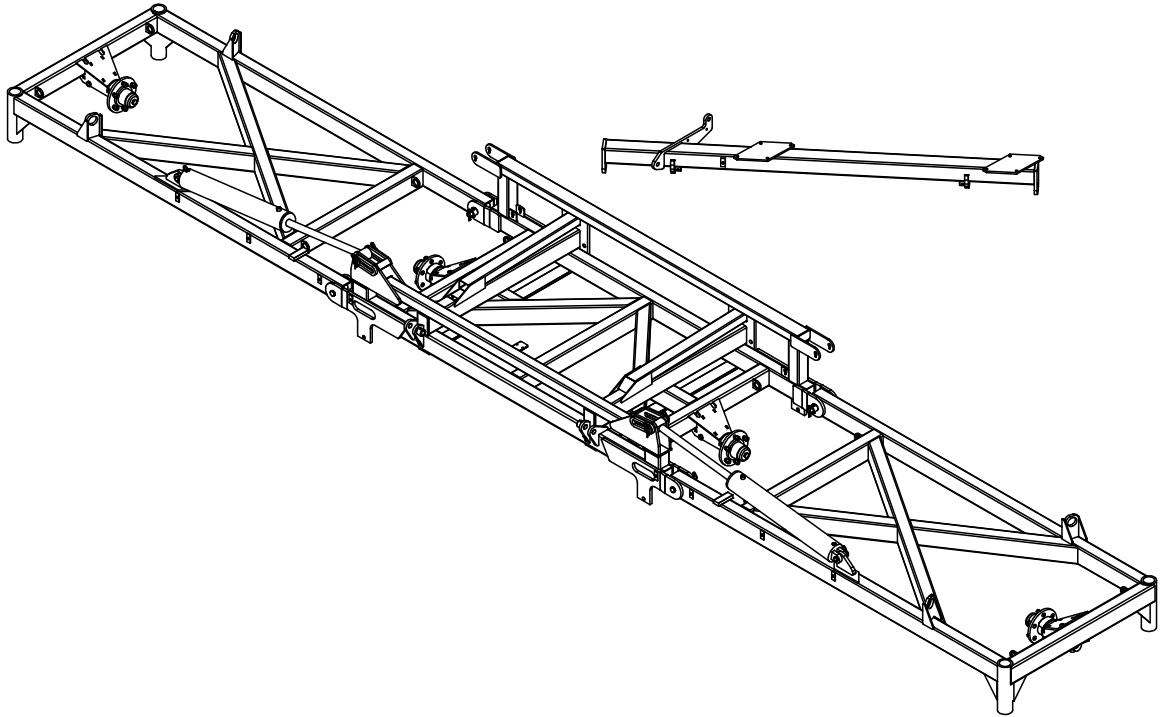

TRAVEL

PART NUMBER	DESCRIPTION	QTY.
0830-02	30' Front A-Frame	1
0211-2475	M24 x 75 8.8 zp Bolt	12
0211-1650	M16 x 50 8.8 zp Bolt	8
0221-NYL16	M16 Nyloc Nut	8
0221-NYL24	M24 Nyloc Nut	12

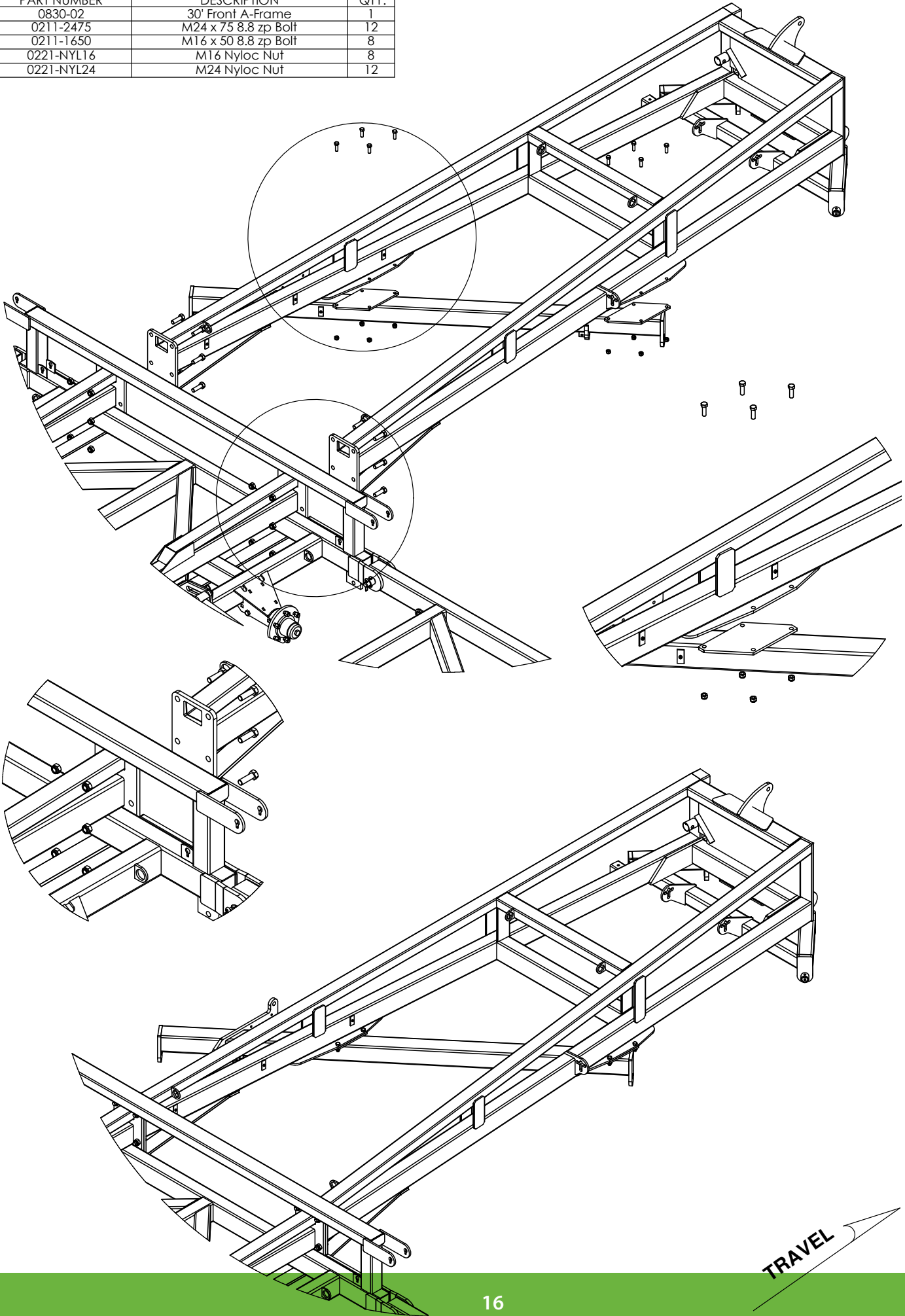

PART NUMBER	DESCRIPTION	QTY.
0751-15.0-70-18TR	15.0/70/18 Tyre and Rim Complete	4

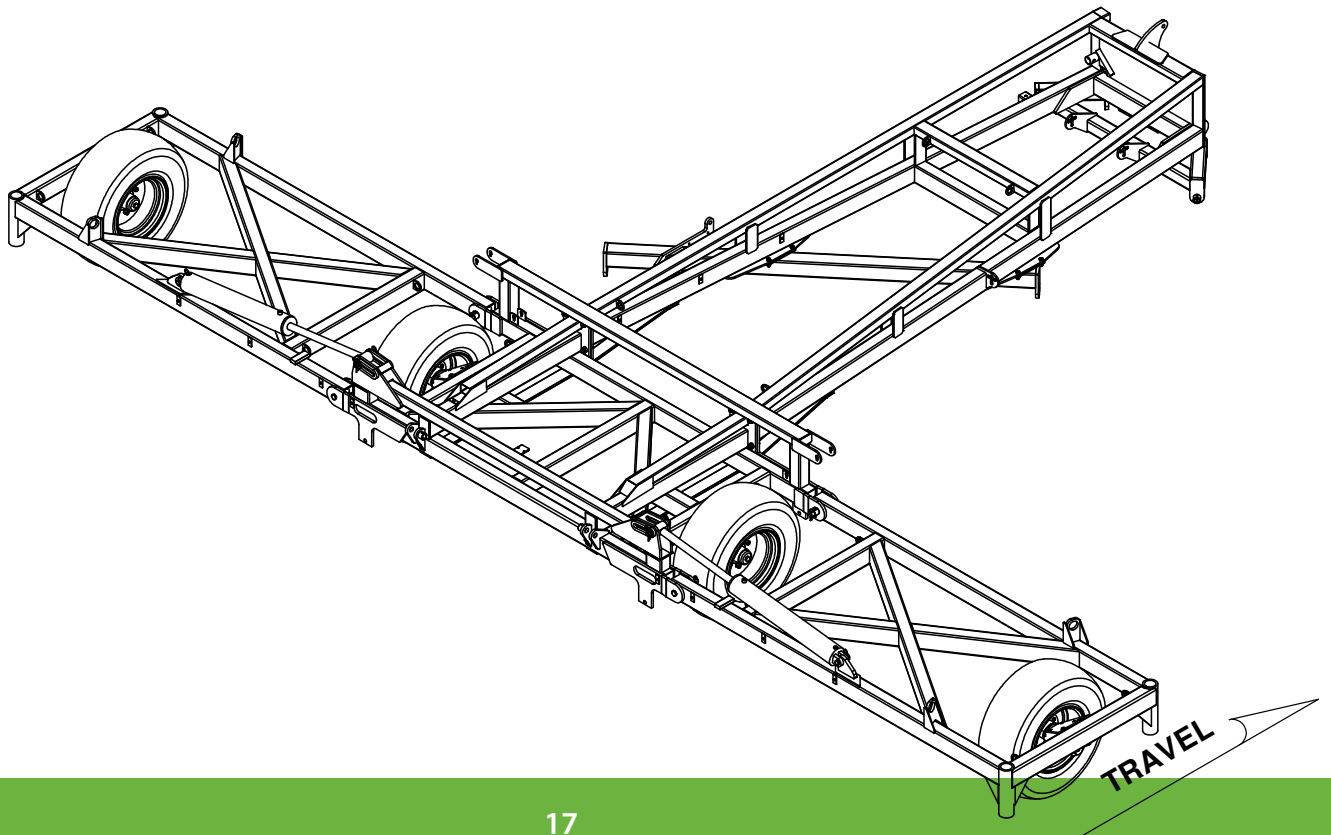
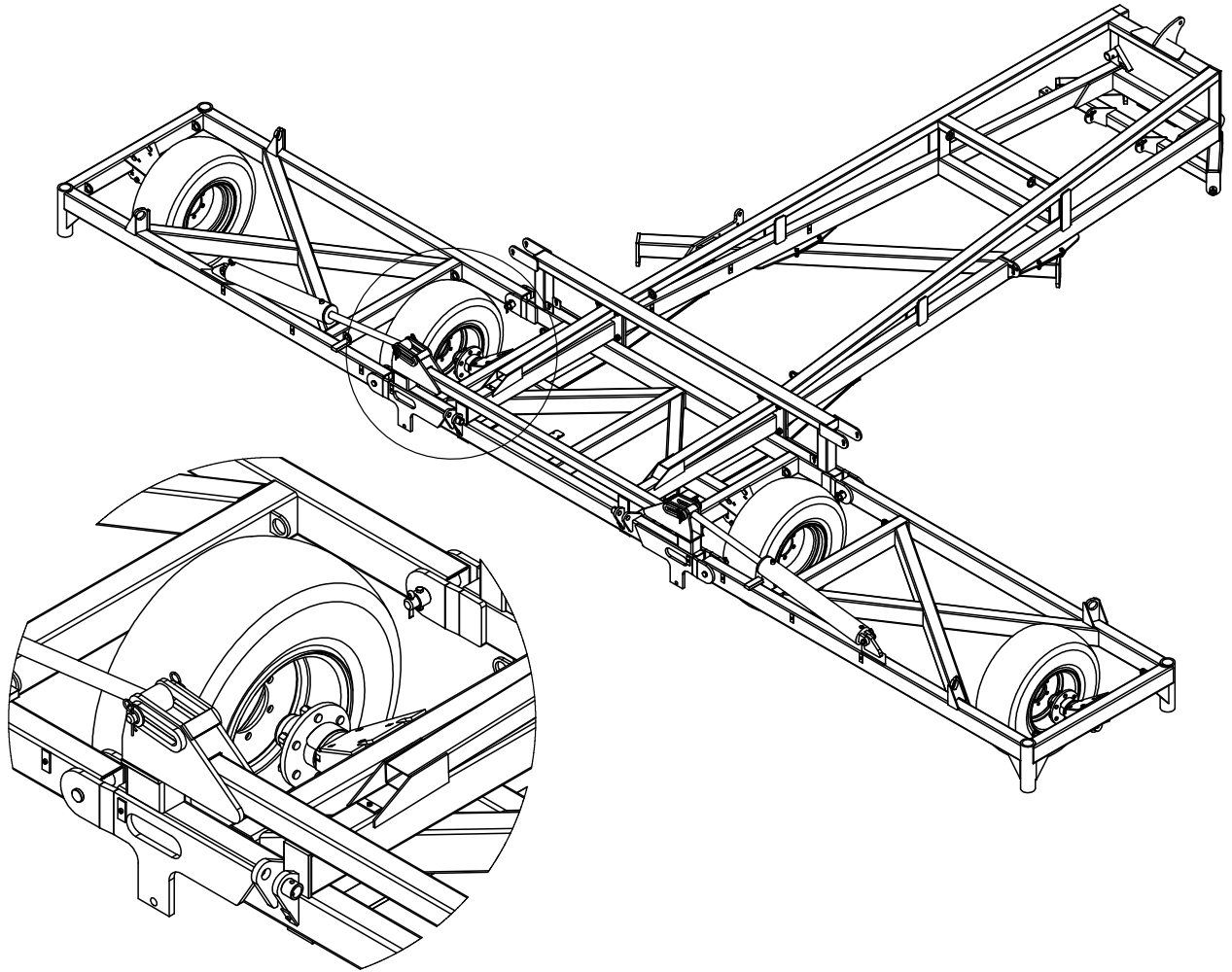

PART NUMBER	DESCRIPTION	QTY.
0810-08	Draw Bar Frame	1
0810-31	Jack Assy	1
0801-10-13-970	Drawbar Pivot Pin	1
0211-1265	M12 x 65 8.8 zp Bolt	1
0221-NYL12	M12 Nyloc Nut	1
0311-312EXT	3" x 12" EXT Hydraulic Cylinder	1
0801-44082938	Clevis Pin 1" x 75mm	2
0511-RCLIP4	R Clip 4mm	2
0801-B3077	Jack Pin	1
0810-151	Hose Post Assy	1
0221-NYL6	M6 Nyloc Nut	3
0261-PINC1363	Cotter Pin M13 X 63mm	1
0211-625	Bolt M6 x 25	3

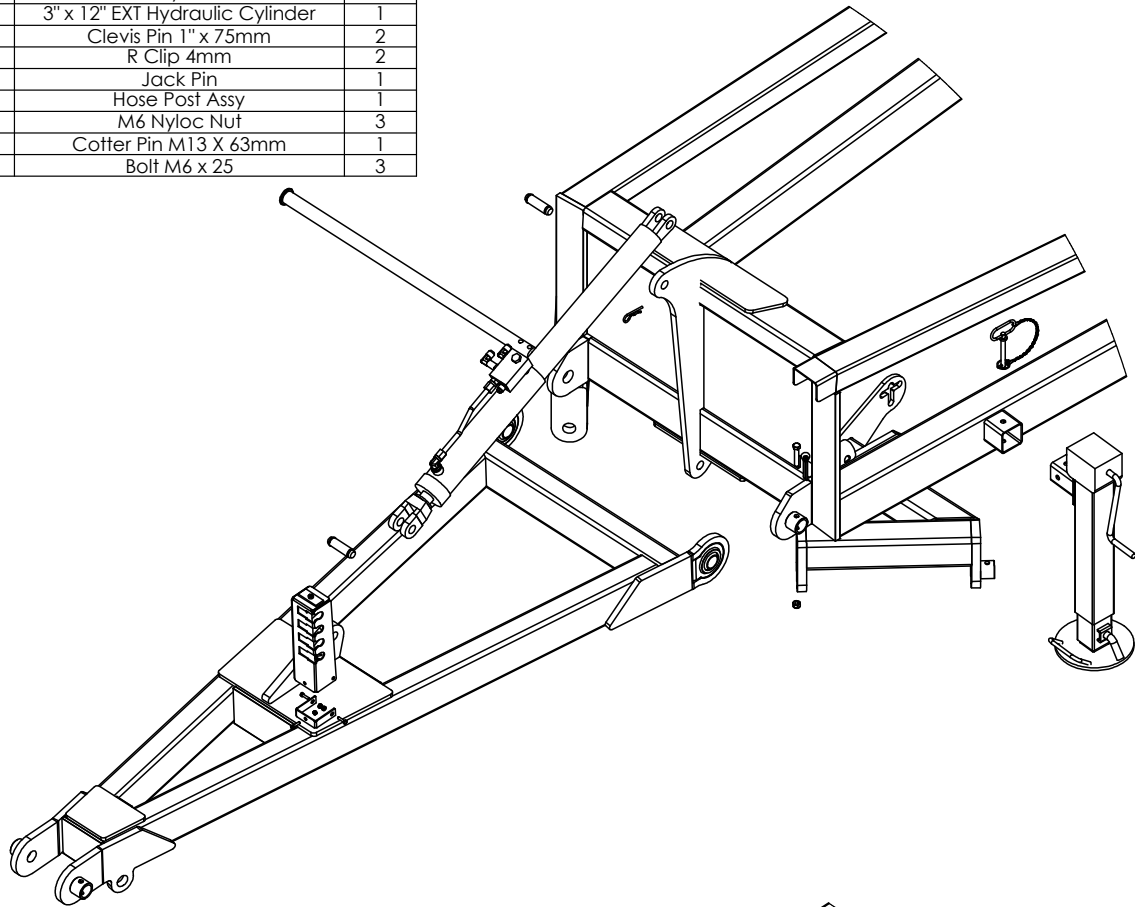

**PLEASE REFER TO
ASSEMBLY UPDATE 019
IN THE BACK OF THE
MANUAL**

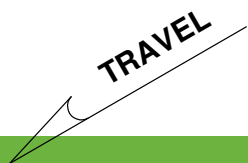
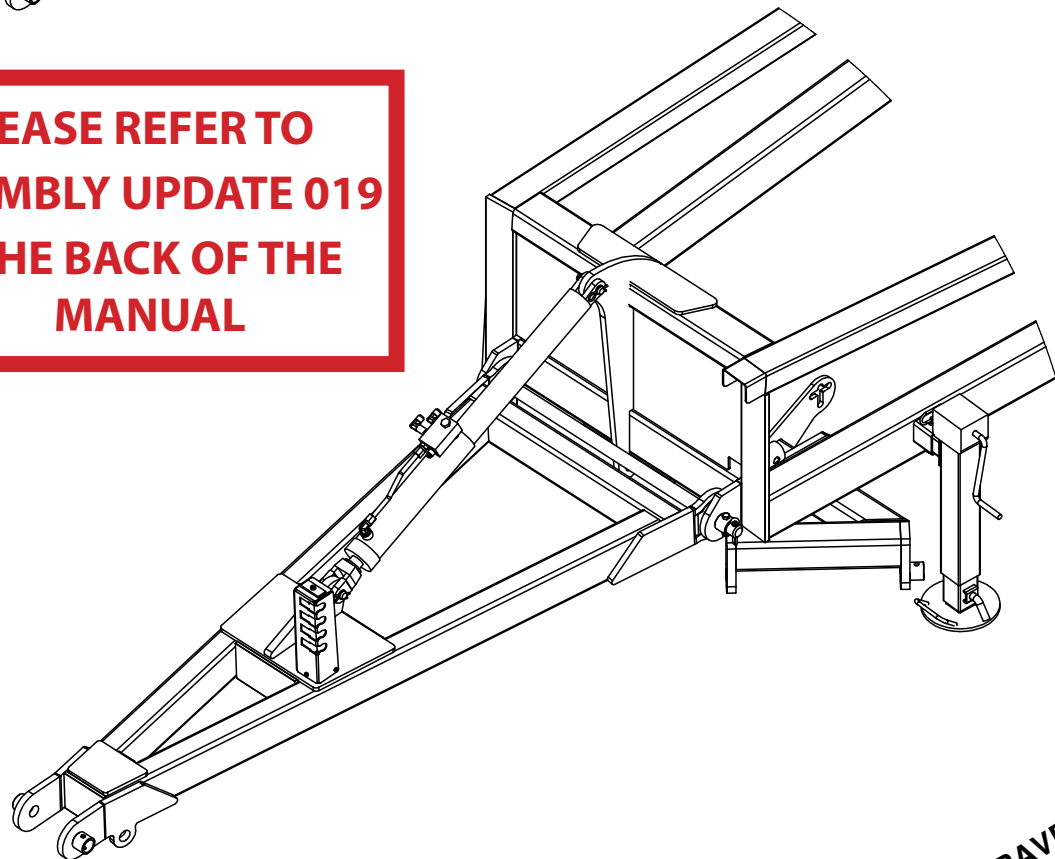

PART NUMBER	DESCRIPTION	QTY.
0810-09	Tow Hitch	1
0810-22	Parallel Arm	1
0801-KE-0905-1-C	Hardened Tow Hitch Bush 2 1/4"	1
0801-10-06	Tow Hitch Pin	1
0801-KE-0307-1	Clevis Pin 25mm x 75mm	2
0231-F12	M12 zp Flat Washer	2
0211-T265	M12 x 65 8.8 zp Bolt	2
0221-NYL12	M12 Nyloc Nut	2
0810-16	Safety Chain Assembly	1
0261-PINC550	Cotter Pin M5 x 50	2
0172-D1400-0820	Circlip External 82mm	1

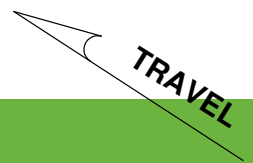
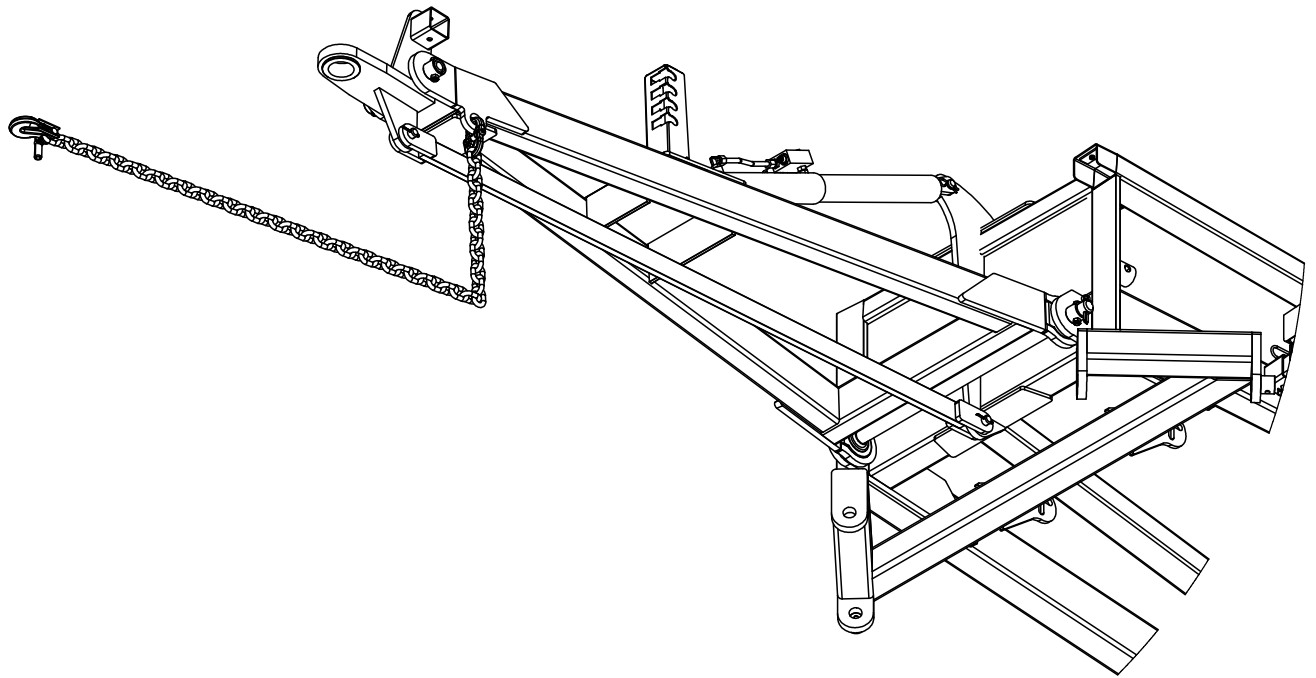
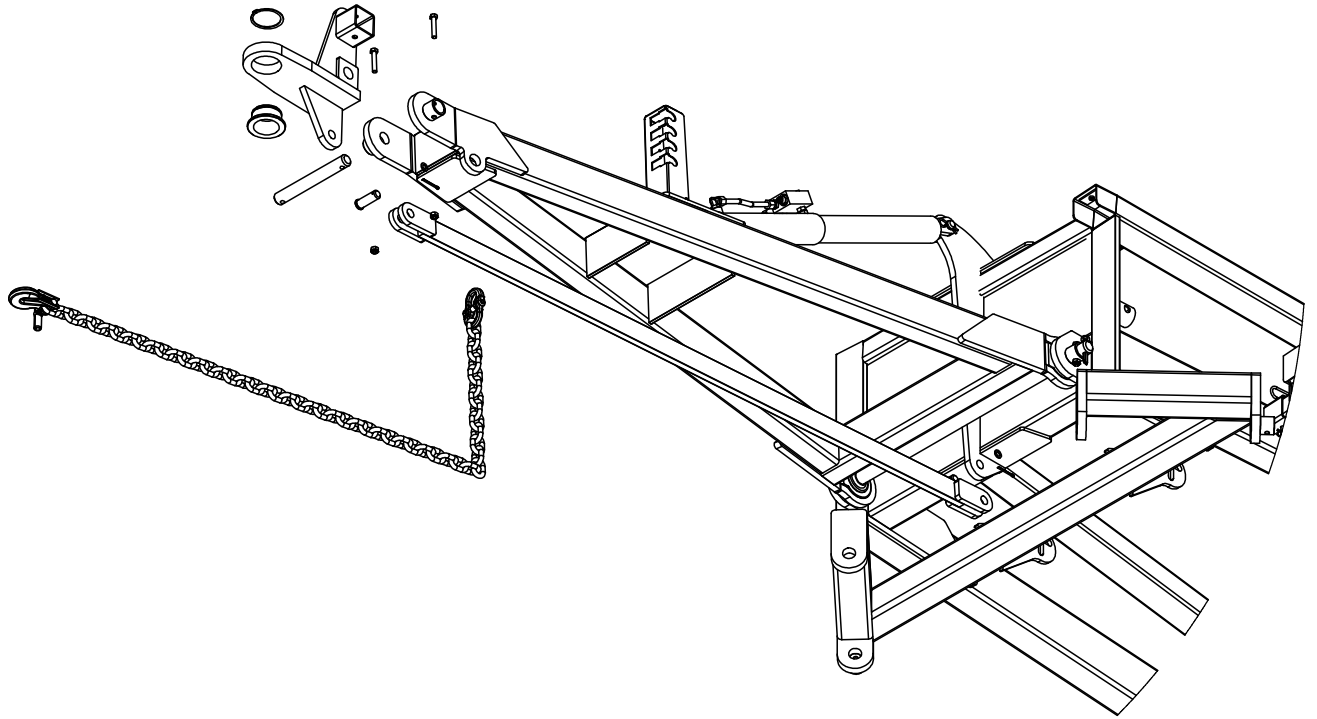

PART NUMBER	DESCRIPTION	QTY.
0810-29-30	30' Rear Module	1

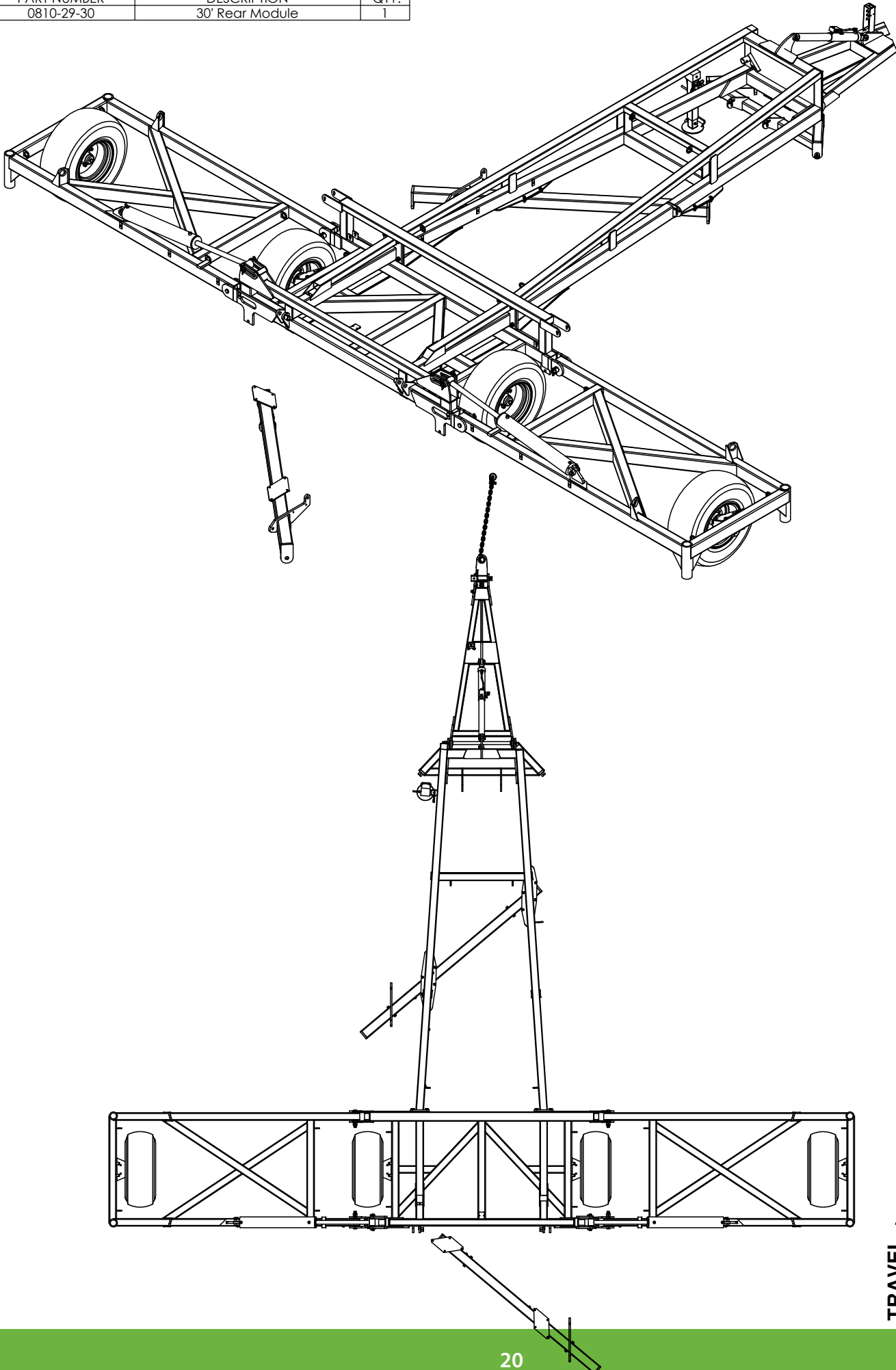

TRAVEL

PART NUMBER	DESCRIPTION	QTY.
0830-03	30' Rear A-Frame	1

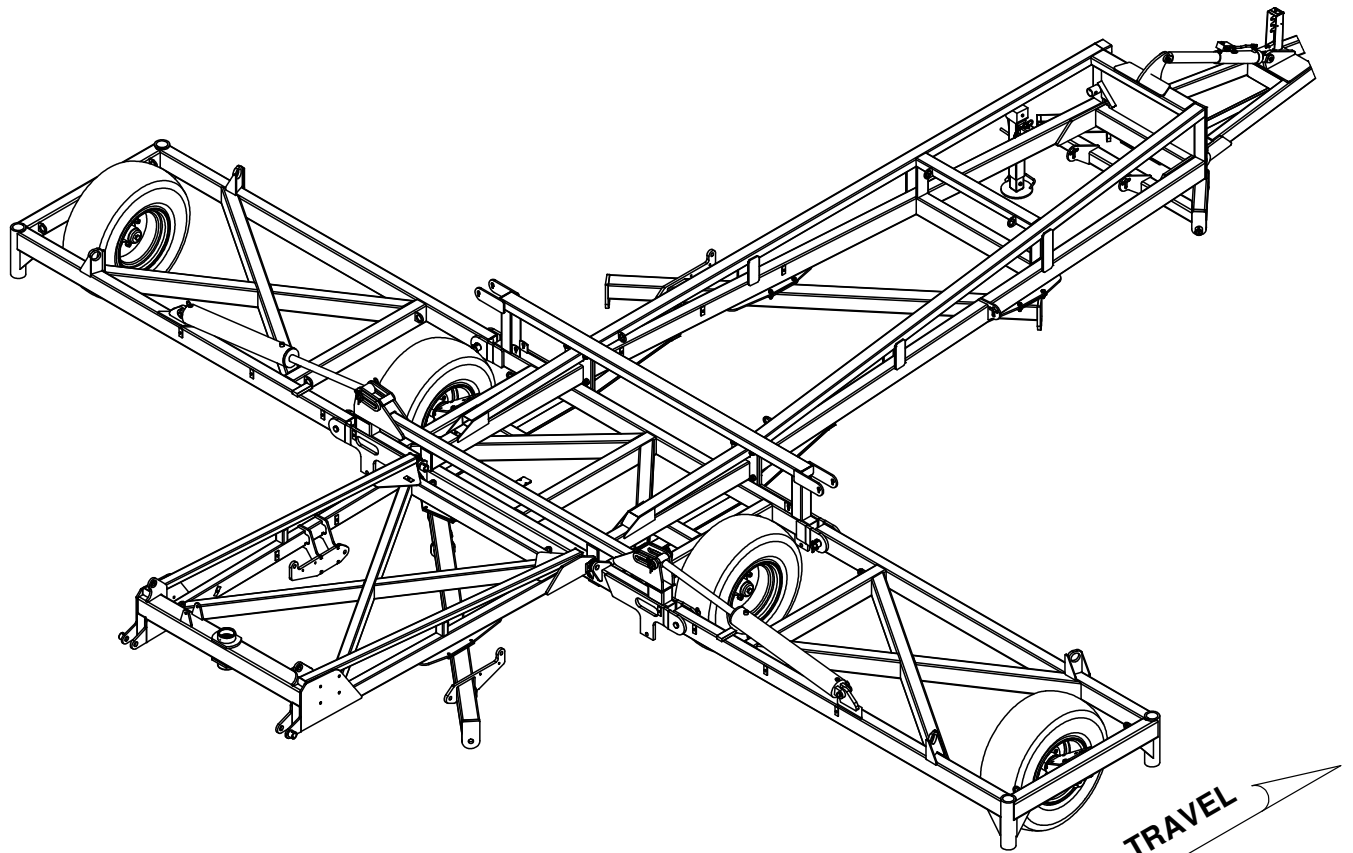
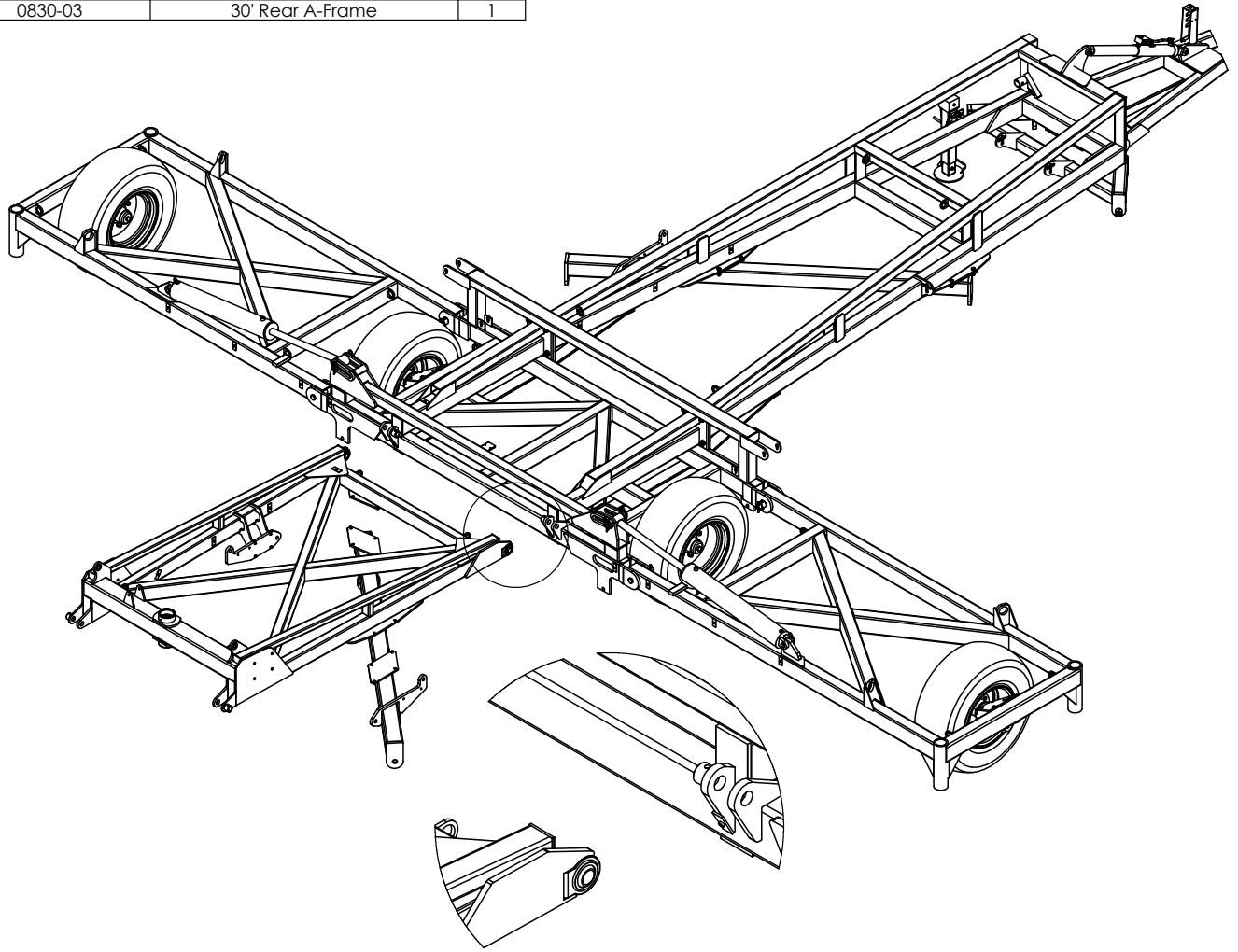

PART NUMBER	DESCRIPTION	QTY.
0810-29-30	30' Rear Module	1

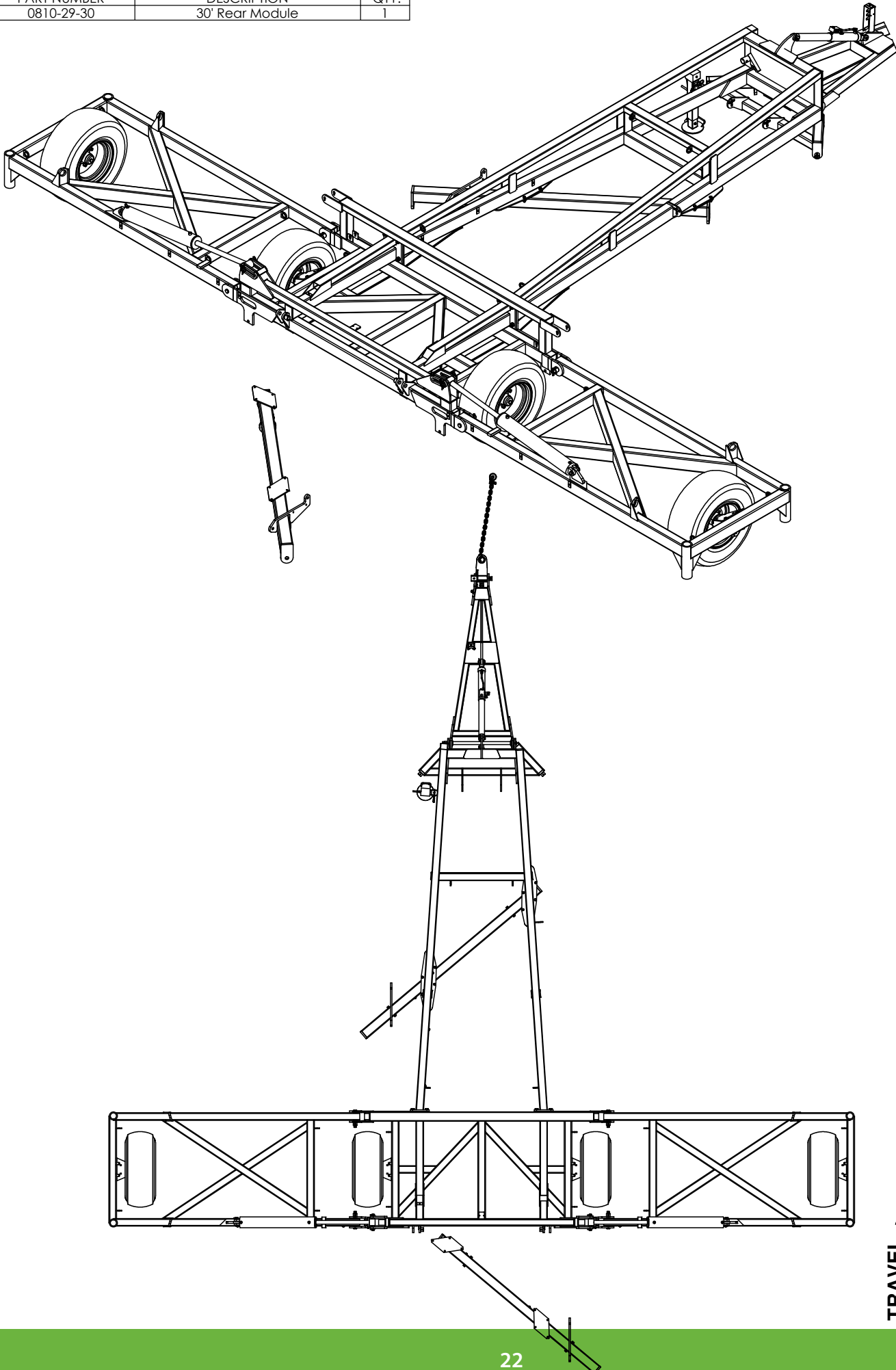

TRAVEL

PART NUMBER	DESCRIPTION	QTY.
0830-03	30' Rear A-Frame	1

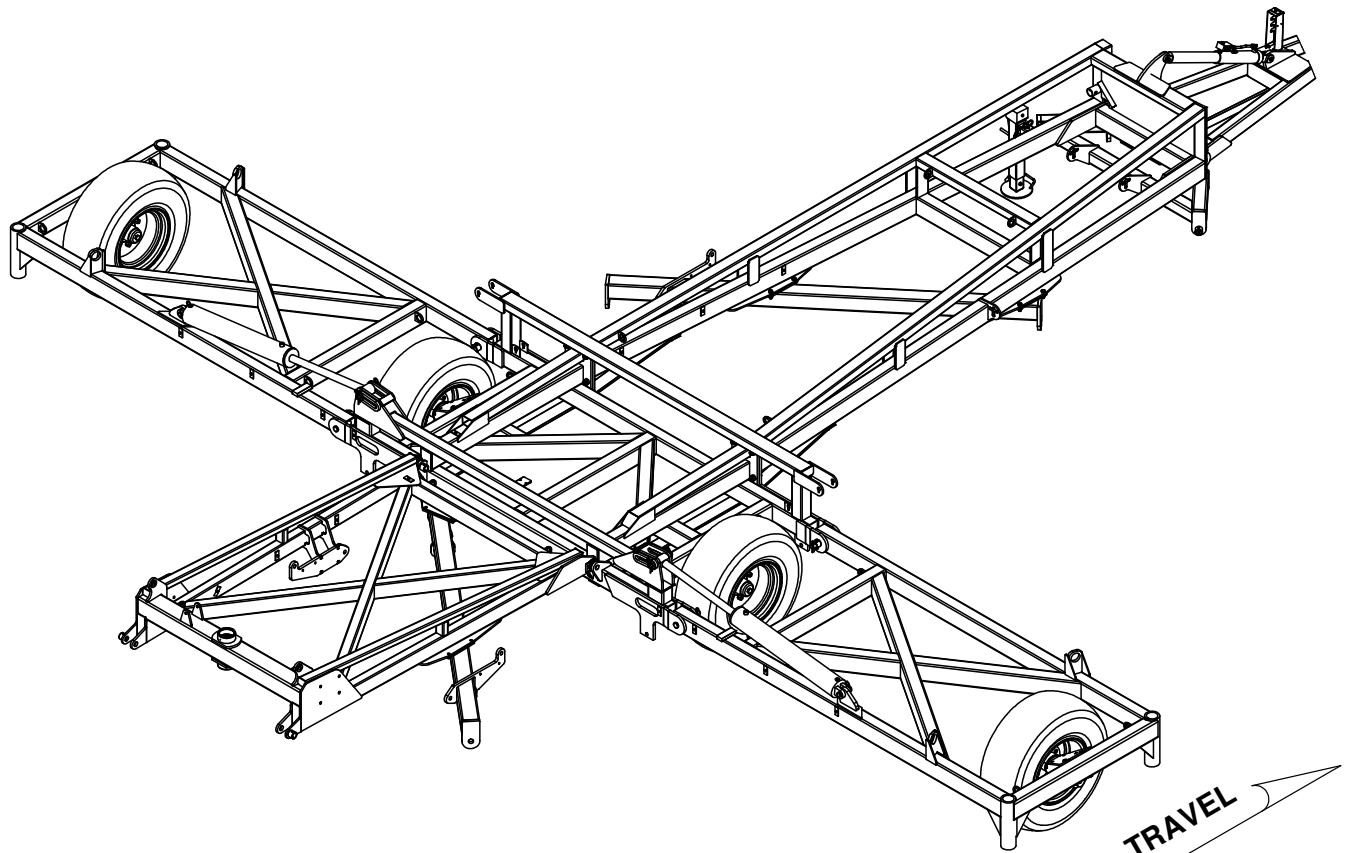
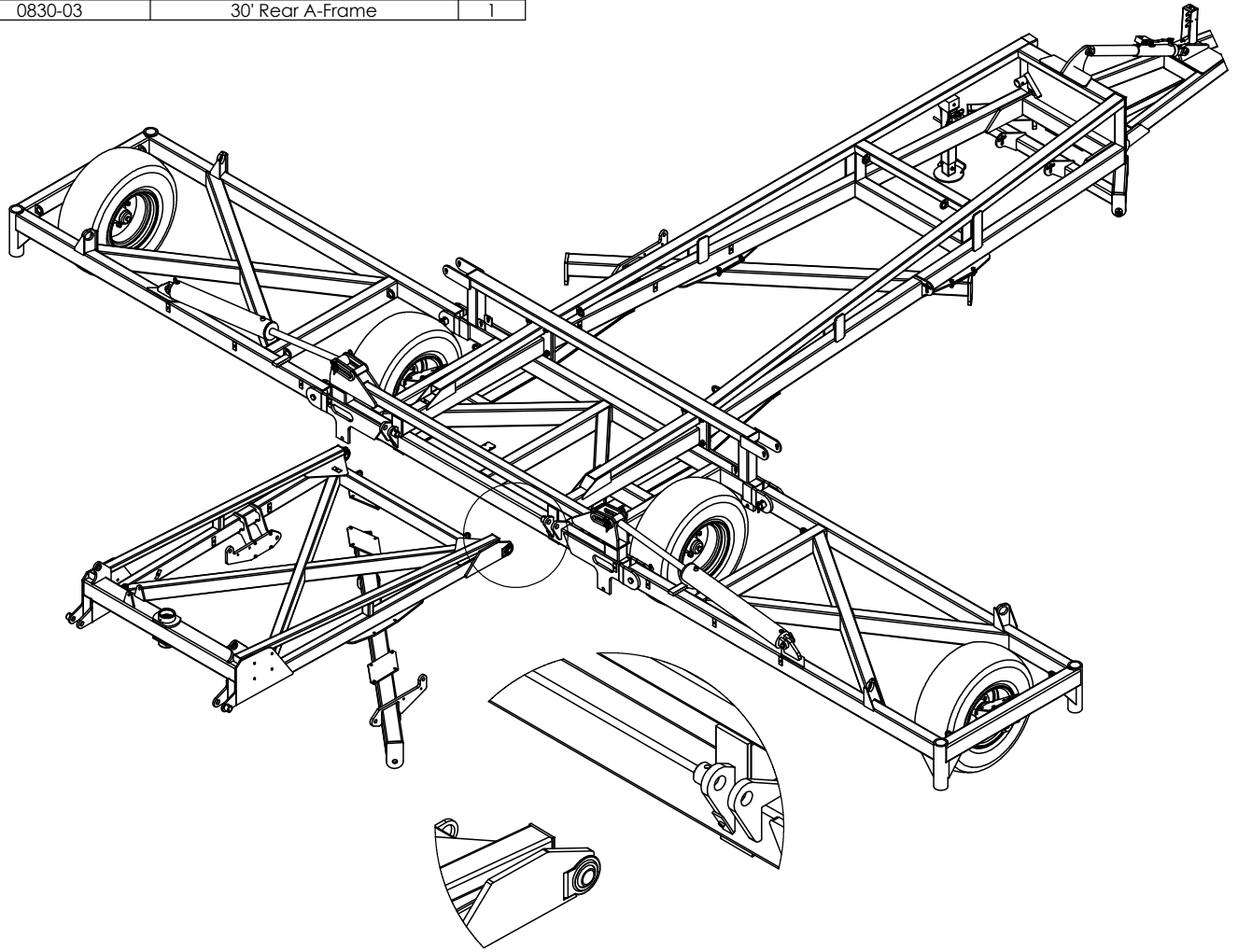

PART NUMBER	DESCRIPTION	QTY.
0801-10-08-175	Tail Frame Pivot pin	2
0211-1265	M12 x 65 8.8 zp Bolt	2
0221-NYL12	M12 Nyloc Nut	2
0211-1650	M16 x 50 8.8 zp Bolt	7
0221-NYL16	M16 Nyloc Nut	7
0261-PINC1363	Cotter Pin M13 X 63mm	2

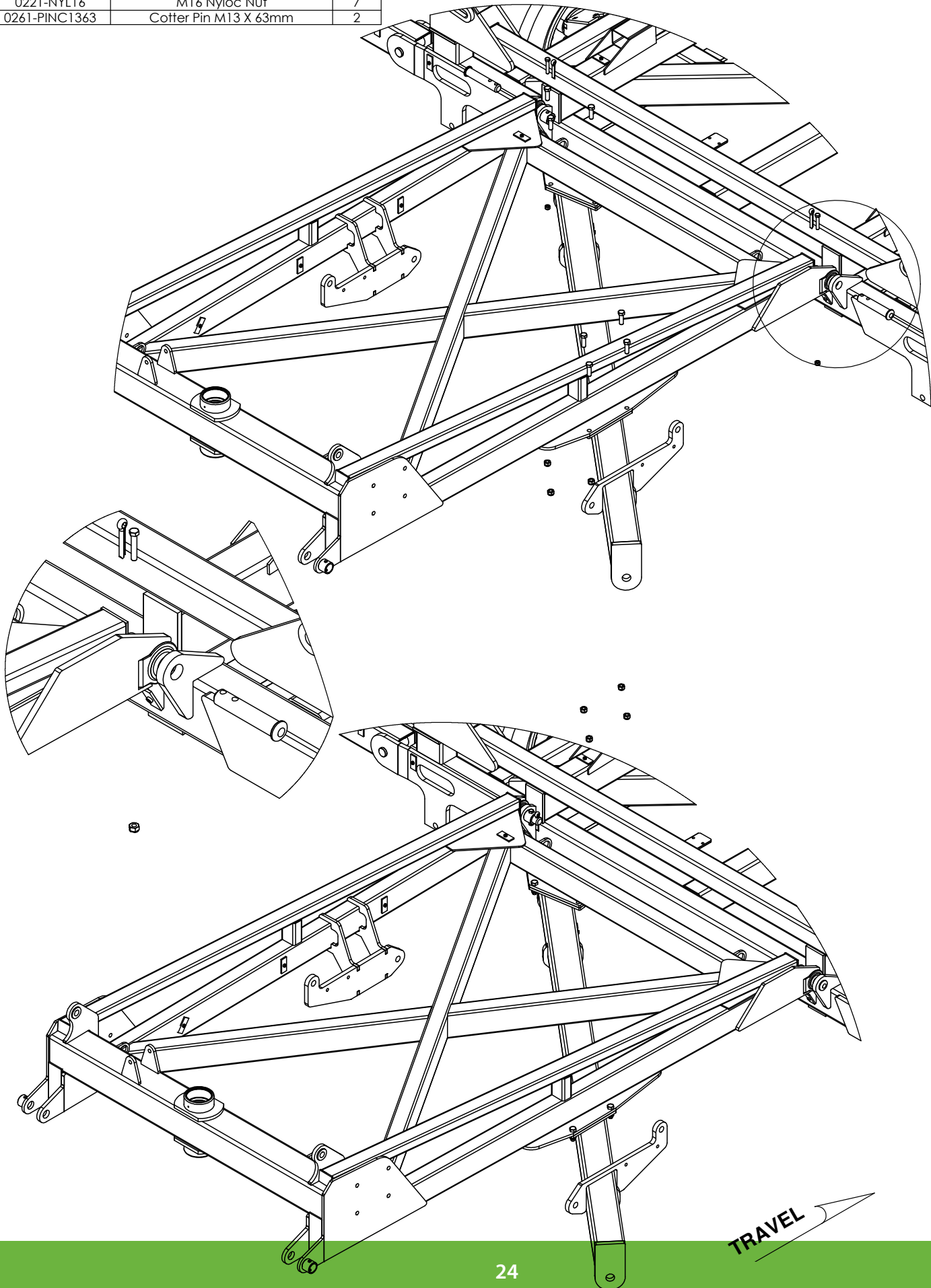

ITEM NO.	PART NUMBER	DESCRIPTION	QTY.
1	0113-GE70DO-2RS	Plain Spherical Bearing 70mm	2
2	0171-J105	Circlip Internal 105mm	2
3	0181-GN1-4	Grease Nipple 1/4" UNF	2
4	0800-02.1	Brake Disc	1
5	0801-KE0705-13	70mm Polymer dust cap	1
6	0801-LOCK01-35	35mm Shaft Lock Clamping Element 01	1
7	0810-11-70	70mm Jockey Wheel	1

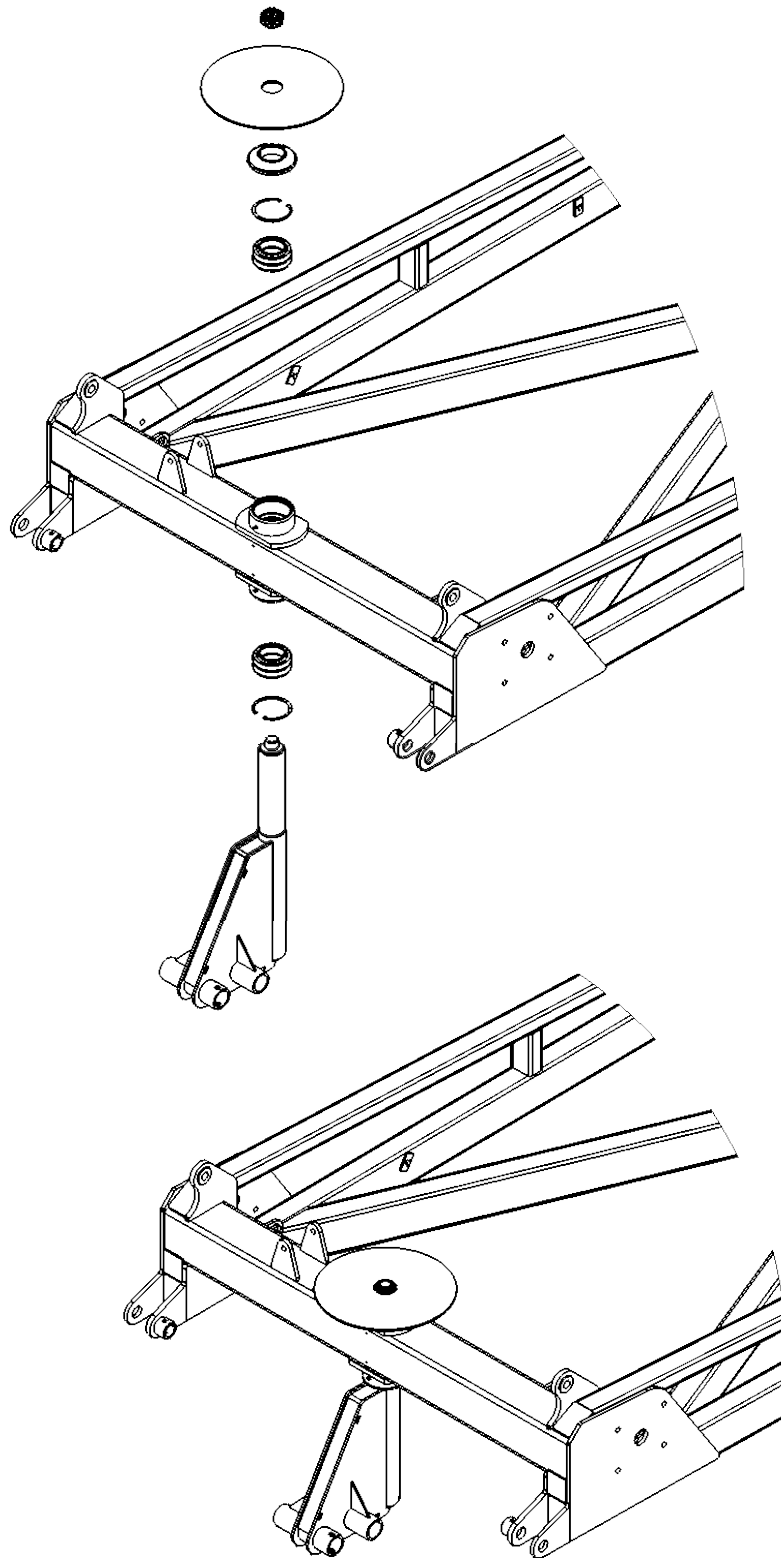

TRAVEL →

ITEM NO.	PART NUMBER	DESCRIPTION	QTY.
1	0211-16150	M16 x 150 grade 8.8 zp Bolt	2
2	0221-NYL16	Nyloc Nut M16	1
3	0231-SQ16505	Washer Square M16 x 50 x 5	1
4	0801-KE009	Brake Compression Spring	1
5	0810-12CAL	Jockey Wheel Brake Caliper	1

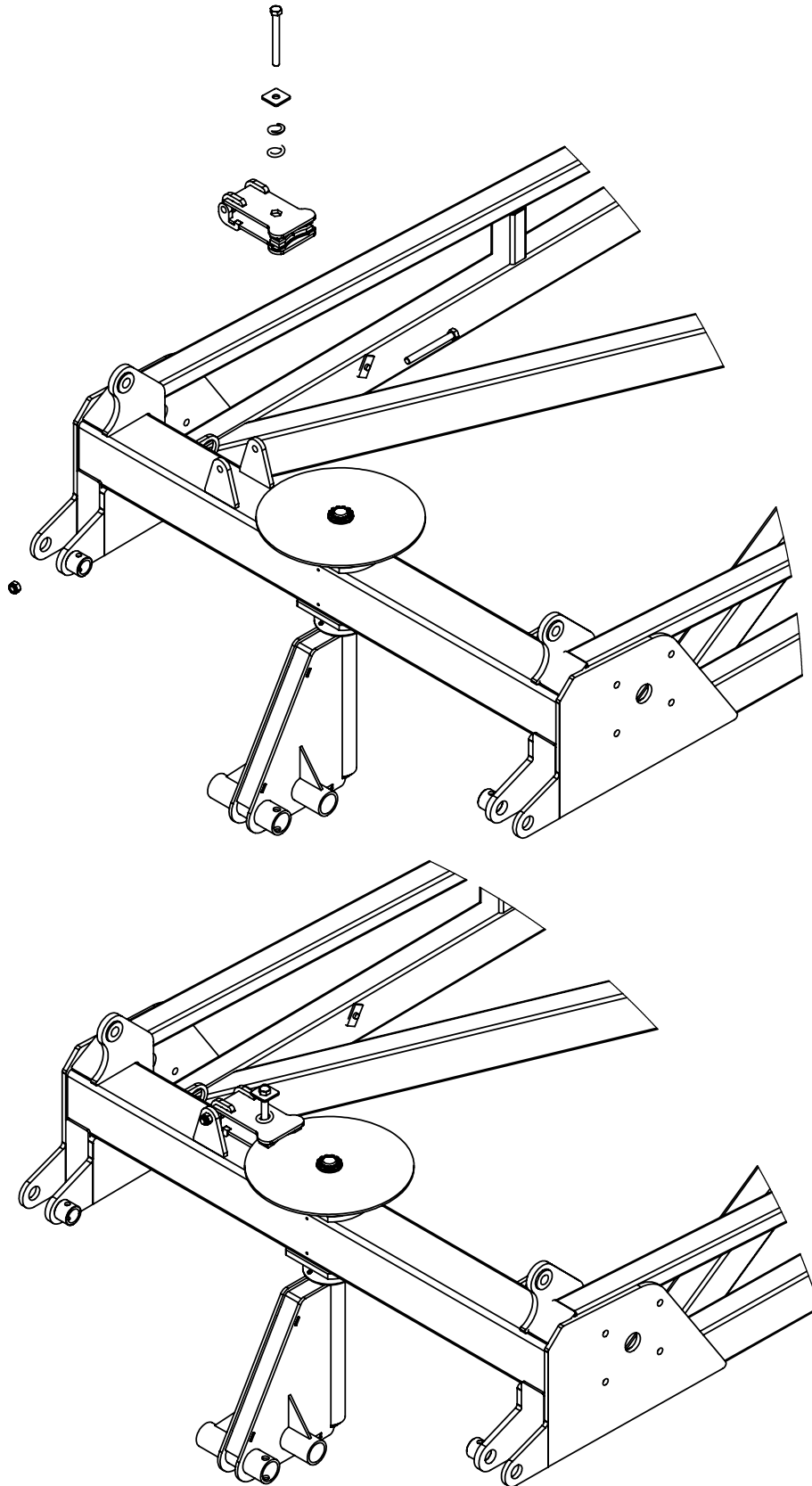

TRAVEL →

ITEM NO.	PART NUMBER	DESCRIPTION	QTY.
1	0211-1690	M16 x 90 grade 8.8 zp Bolt	2
2	0221-NYL16	Nyloc Nut M16	2
3	0733-K5083T66S	Axle 2"R 3T 6 on 6" PCD 330 OHF	2
4	0751-11L15	11L15 F3 Tyre on 6 on 6" Stud Rim	2

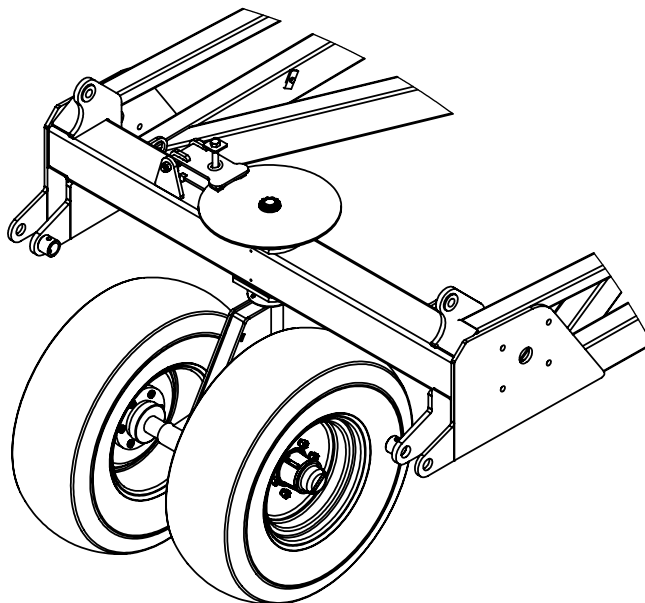
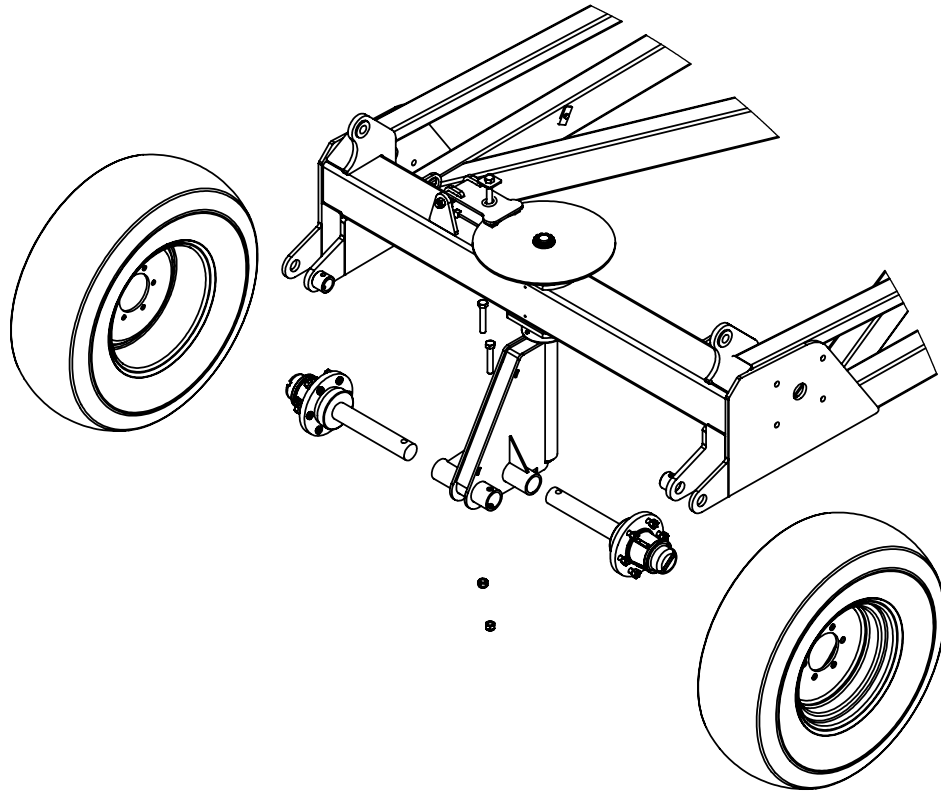

TRAVEL

ITEM NO.	PART NUMBER	DESCRIPTION	QTY.
1	0211-1265	M12 x 65 grade 8.8 ZP Bolt	2
2	0221-NYL12	Nyloc Nut M12	2
3	0261-PINC1363	Cotter Pin M13 x 63	2
4	0801-10-08-175	Tail Frame Pivot pin	2
5	0810-10E	Extended Tip Rear Tail	1

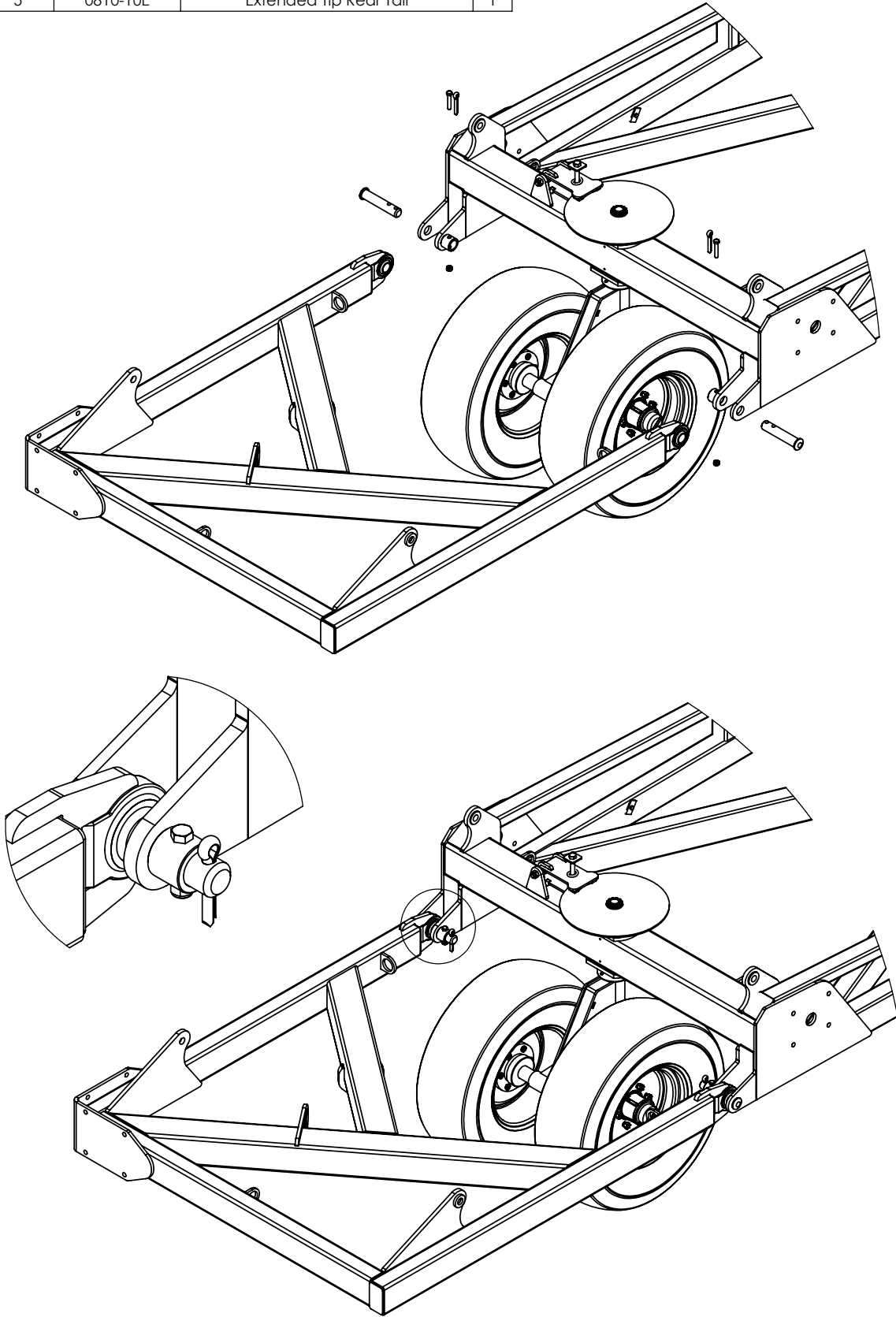

TRAVEL →

ITEM NO.	PART NUMBER	DESCRIPTION	QTY.
1	0311-3524SP	3.5" Bore 24" Stroke 1.75" Rod Hydraulic Cylinder	2

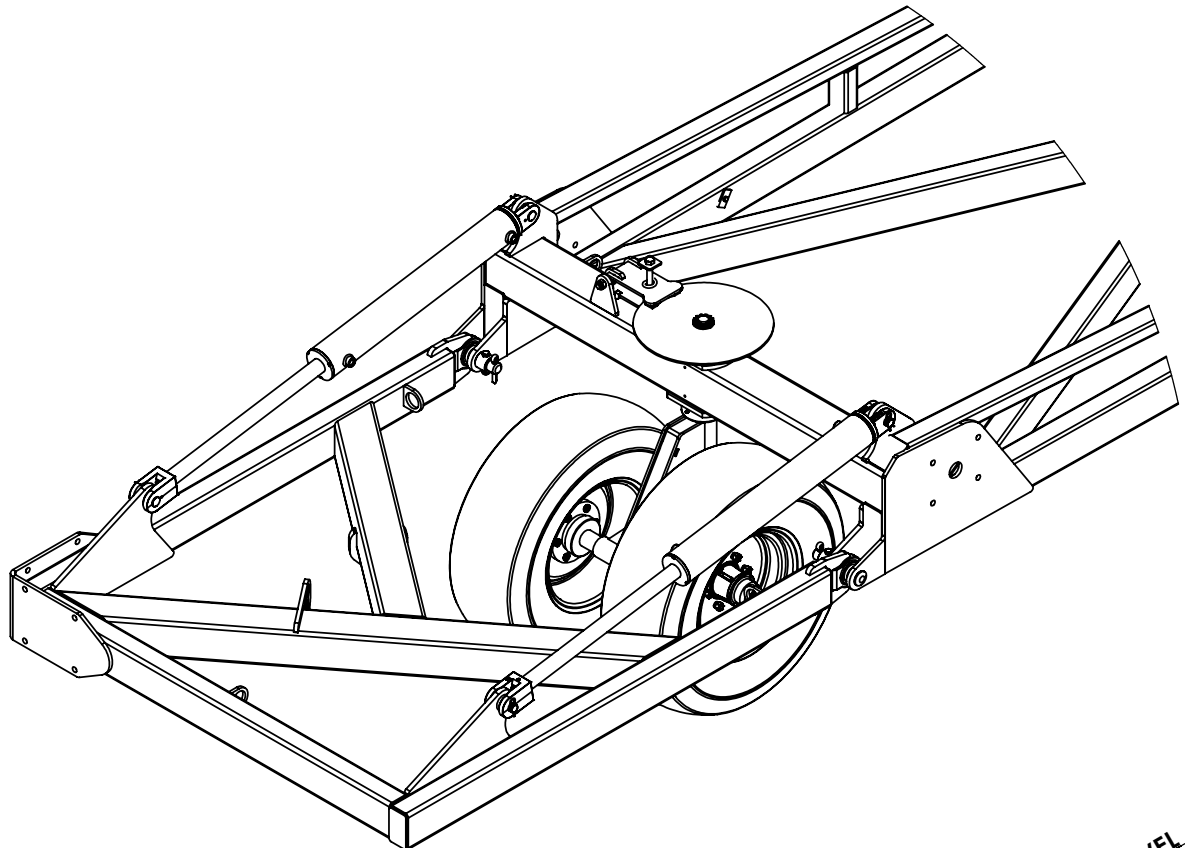
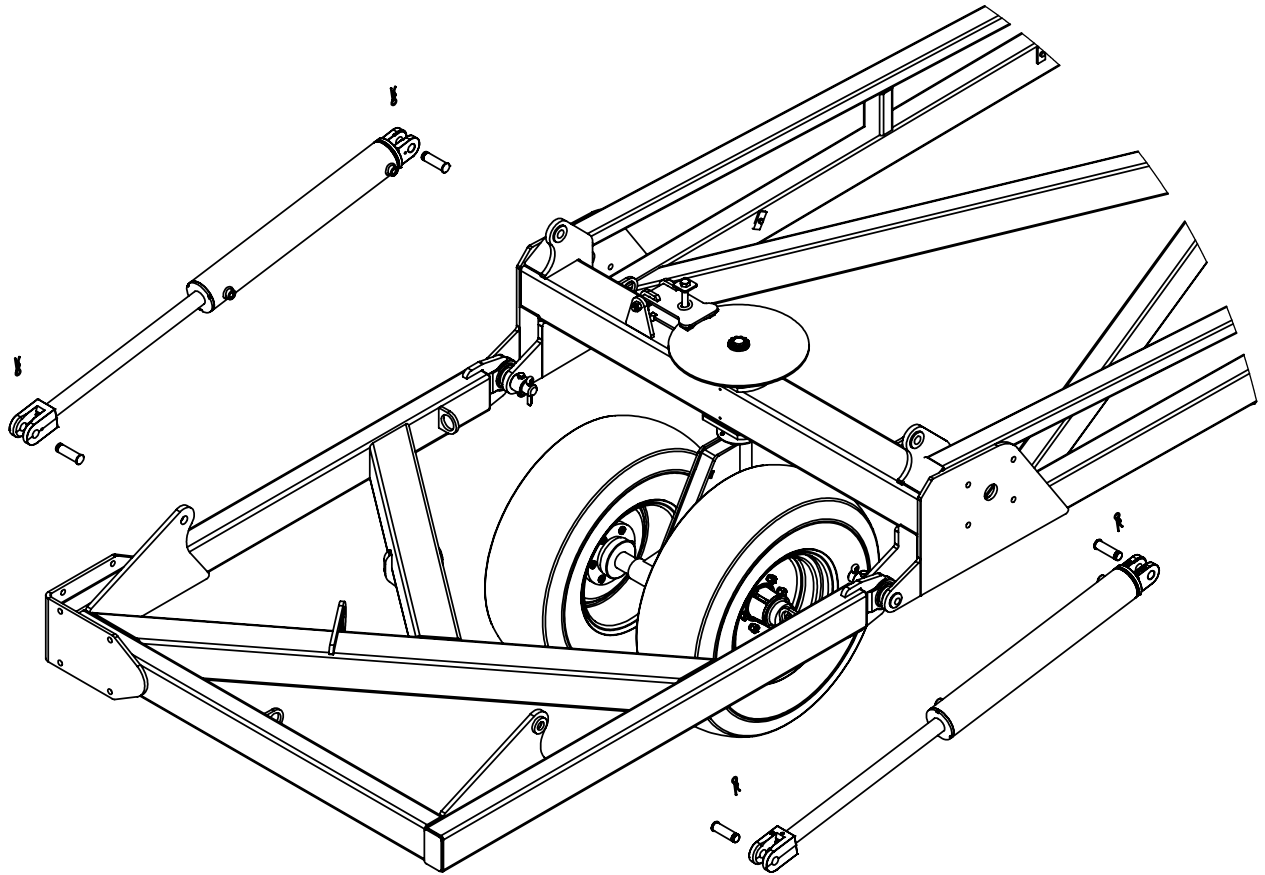

TRAVEL →

ITEM NO.	PART NUMBER	DESCRIPTION	QTY.
1	0211-1650	M16 x 50 grade 8,8 zp Bolt	8
2	0221-NYL16	Nyloc Nut M16	8
3	0231-F16	Washer Flat M16	16
4	0810-10ET	Extended Tip Tail Bolt On Tip	1

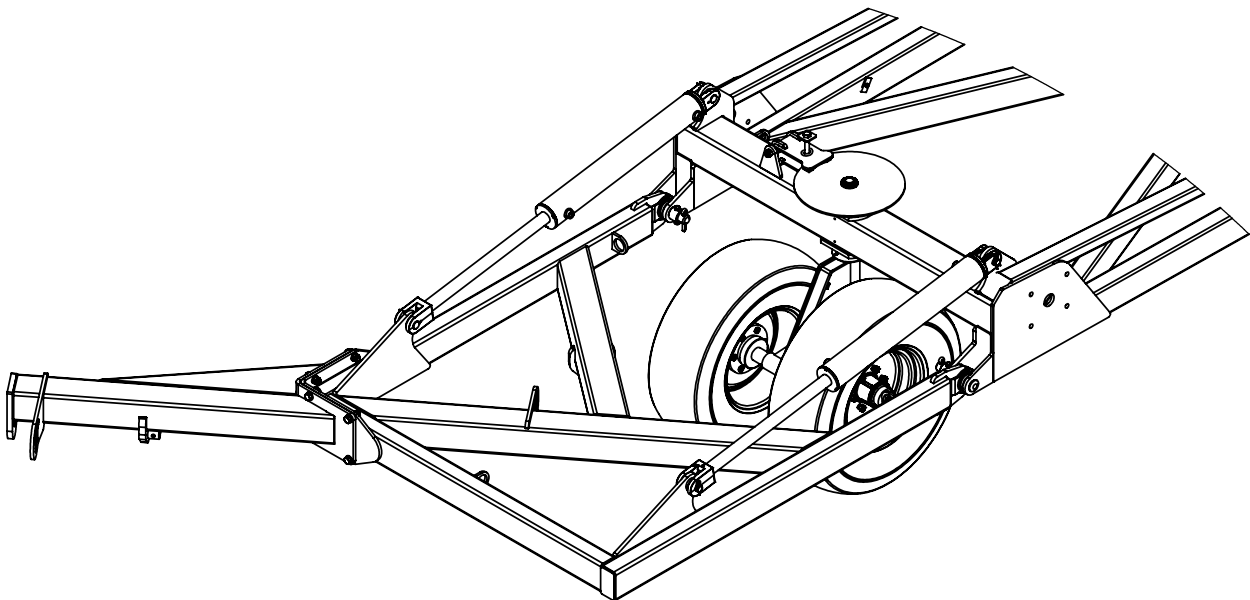
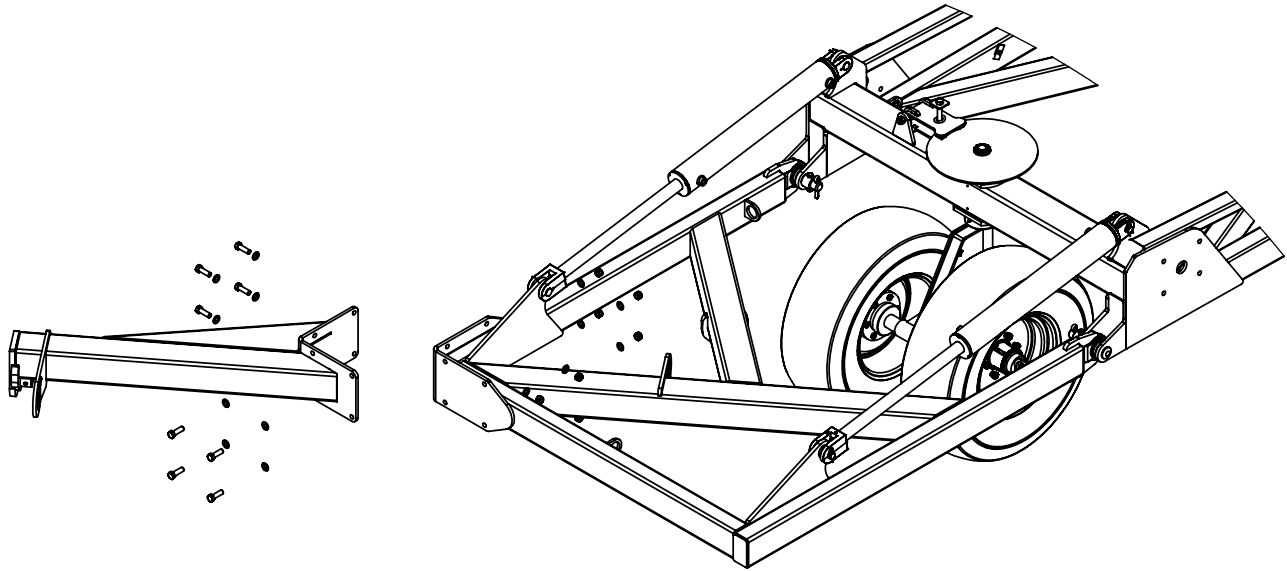

TRAVEL →

ITEM NO.	PART NUMBER	DESCRIPTION	QTY.
1	0221-NYL12	Nyloc Nut M12	16
2	0231-F12	Washer Flat M12	16
3	0271-1215577	U-Bolt M12 x 155 Deep x 77 Wide	8
4	0800-220.1	Tail Chain Stop Guard	1
5	0800-235	Rear Tail Guard	2
6	0800-498	Angled Chain Gaurd	1

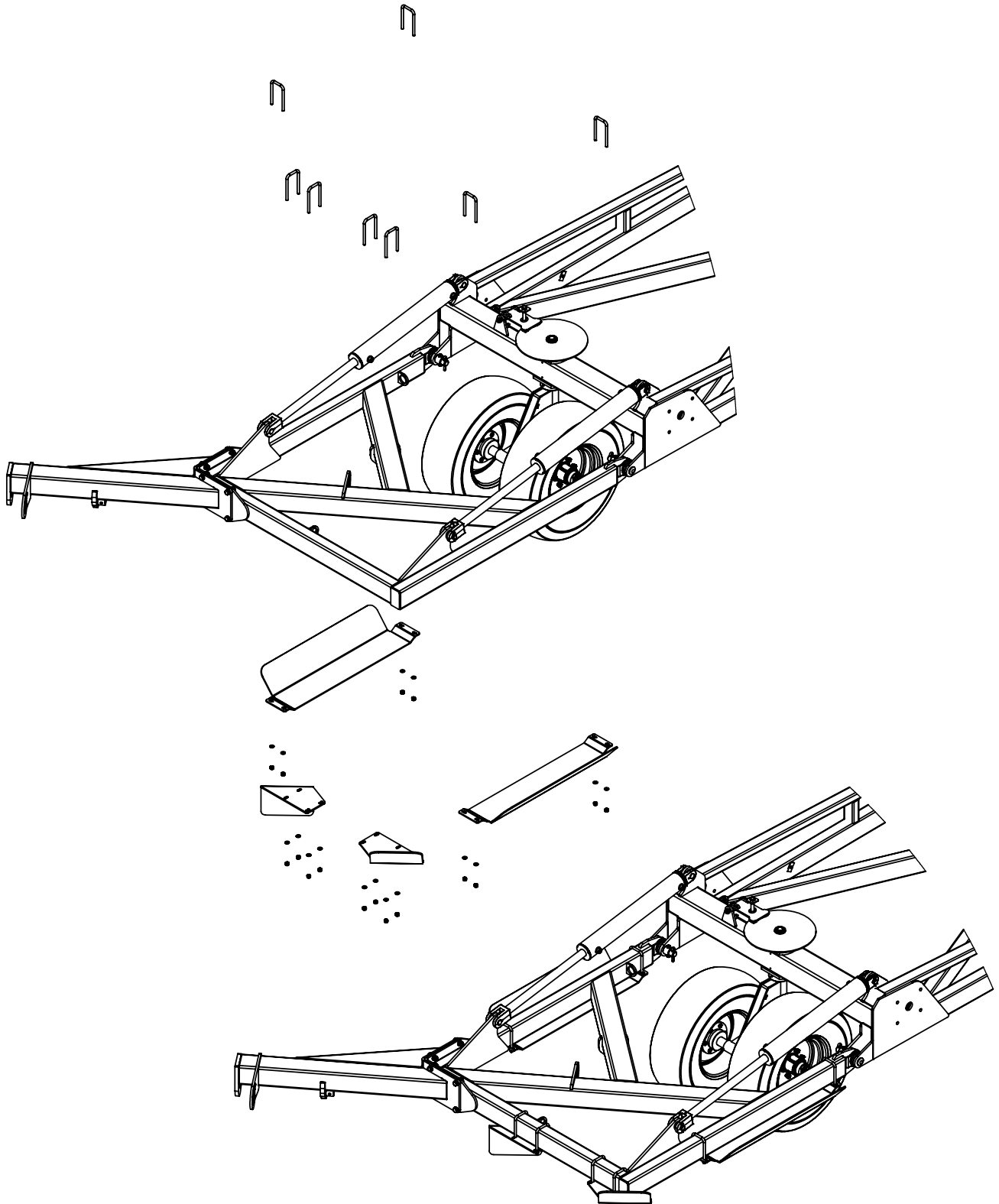

TRAVEL →

PART NUMBER	DESCRIPTION	QTY.
0801-44082938	Clevis Pin 1" x 75mm	2
0511-RCLIP4	R Clip 4mm	2
0801-KE-0307-1	Clevis Pin 25mm x 75mm	1
0810-106	30' Module Lift Arm	1
0231-F24	M24 zp Flat Washer	1
0311-5041	2 1/2" x 6" Hydraulic Cylinder Side Port	1
0261-PINC550	Cotter Pin M5 x 50	1

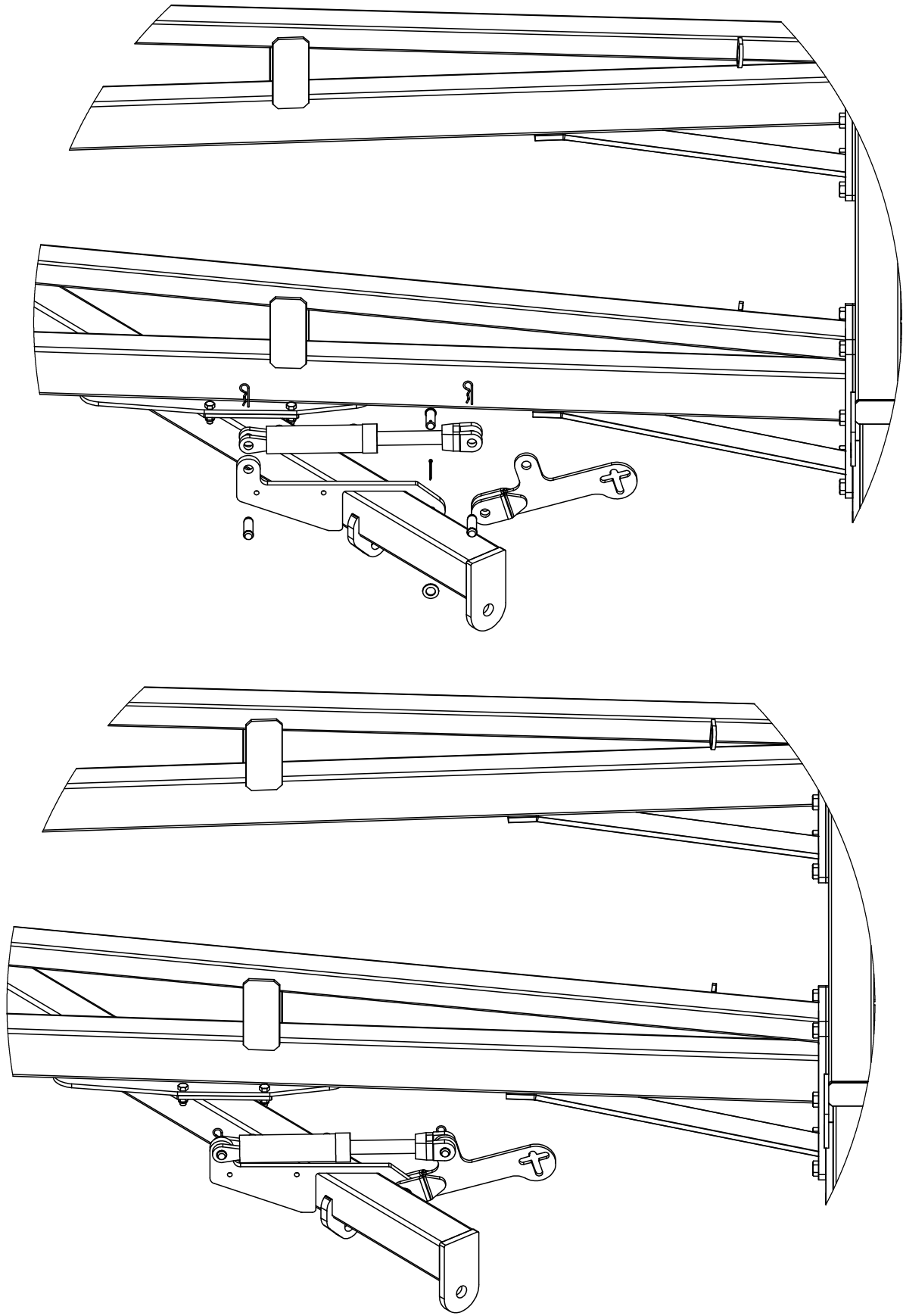

PART NUMBER	DESCRIPTION	QTY.
0801-44082938	Clevis Pin 1" x 75mm	2
0511-RCLIP4	R Clip 4mm	2
0801-KE-0307-1	Clevis Pin 25mm x 75mm	1
0810-106	30' Module Lift Arm	1
0311-5041	2 1/2" x 6" Hydraulic Cylinder Side Port	1
0231-F24	M24 zp Flat Washer	1
0261-PINC550	Cotter Pin M5 x 50	1

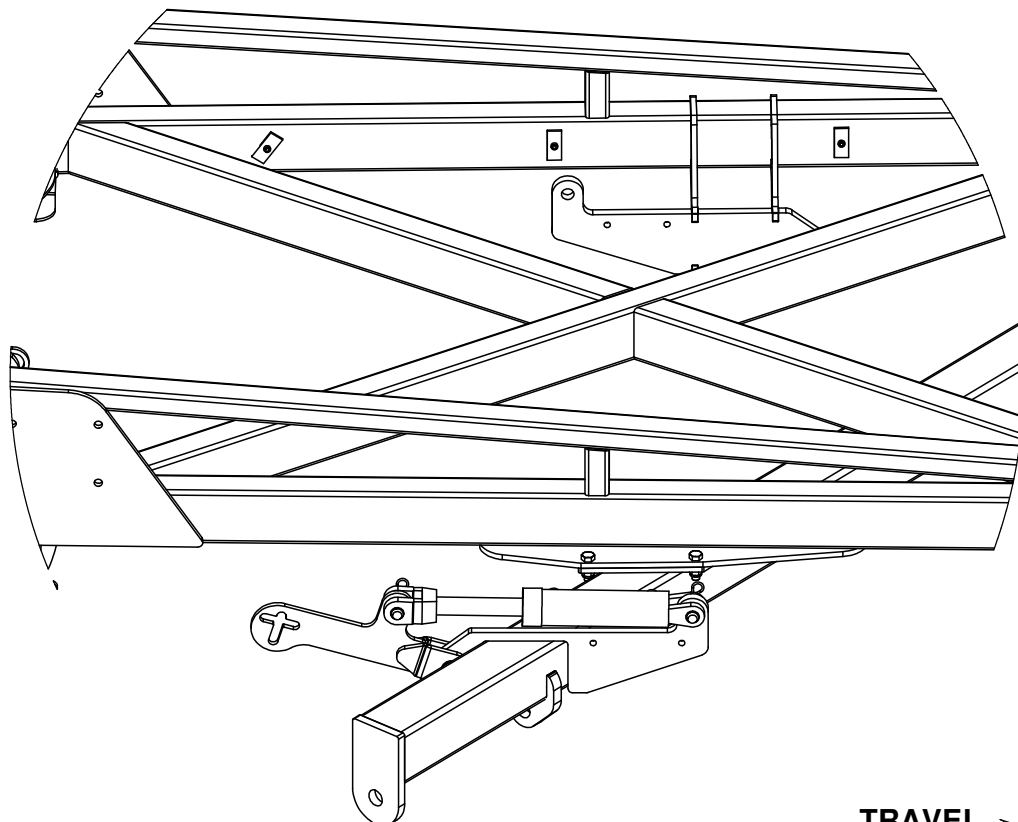
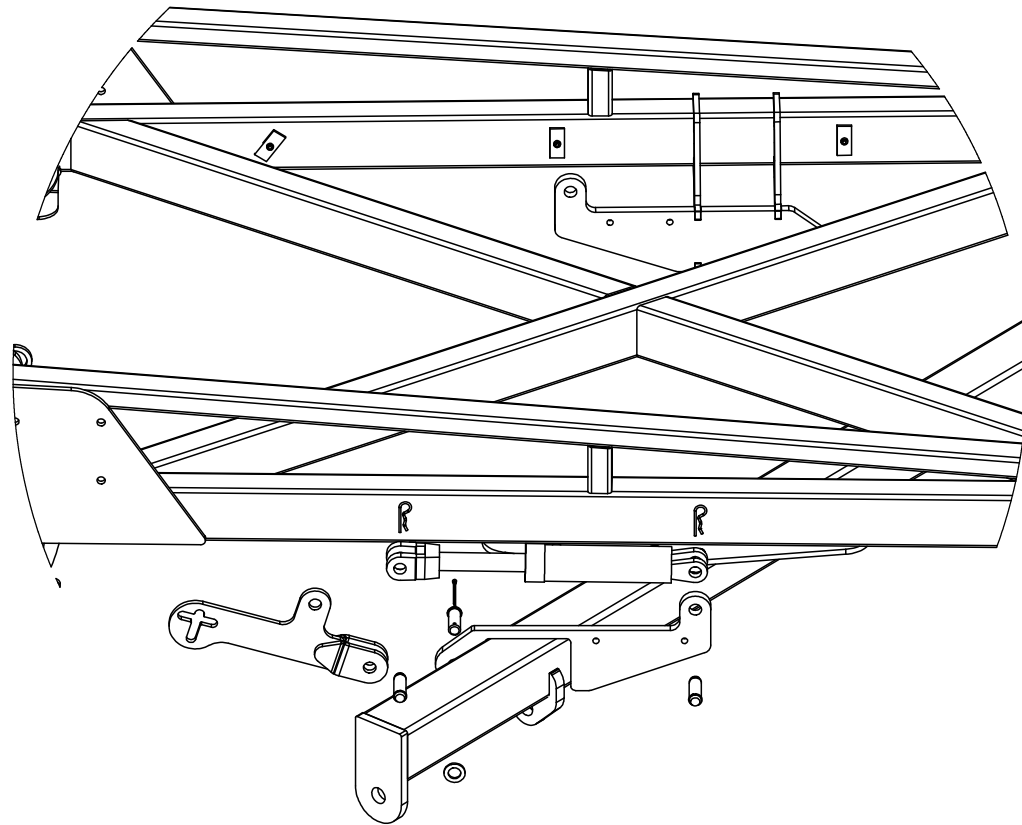

TRAVEL

PART NUMBER	DESCRIPTION	QTY.
0801-44082938	Clevis Pin 1" x 75mm	2
0511-RCLIP4	R Clip 4mm	2
0801-KE-0307-1	Clevis Pin 25mm x 75mm	1
0311-5041	2 1/2" x 6" Hydraulic Cylinder Side Port	1
0231-F24	M24 zp Flat Washer	1
0810-107	30' Module Lift Arm Short	1
0261-PINC550	Cotter Pin M5 x 50	1

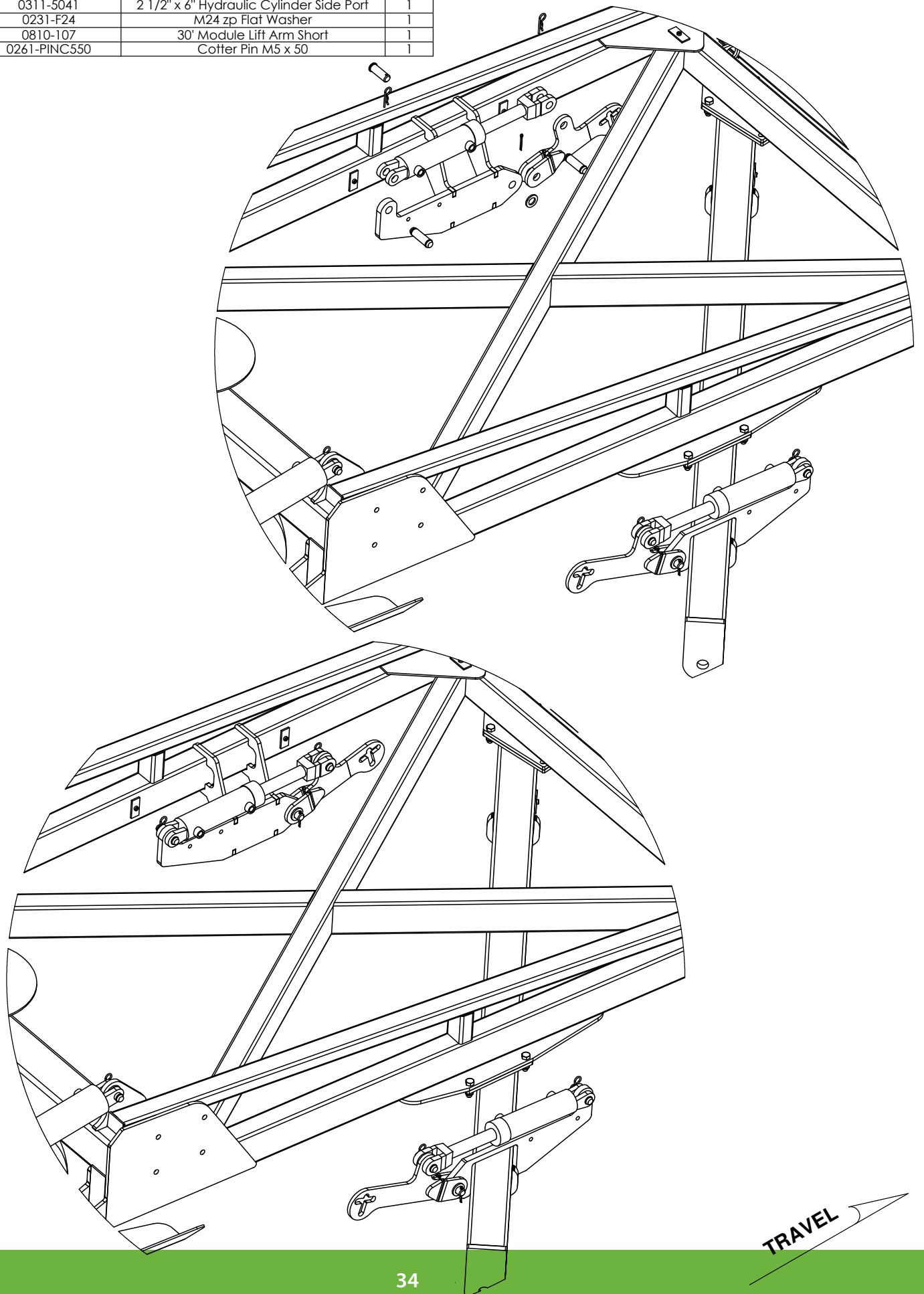

PART NUMBER	DESCRIPTION	QTY.
0231-F12	M12 Flat Washer	8
0221-NYL12	M12 Nyloc Nut	8
0810-17L	Chain Carrier Bolt on End	2
0810-17-30	30' Chain Carrier Beam	1
0215-CH1240	M12 x 40 Coach Head Bolt	8

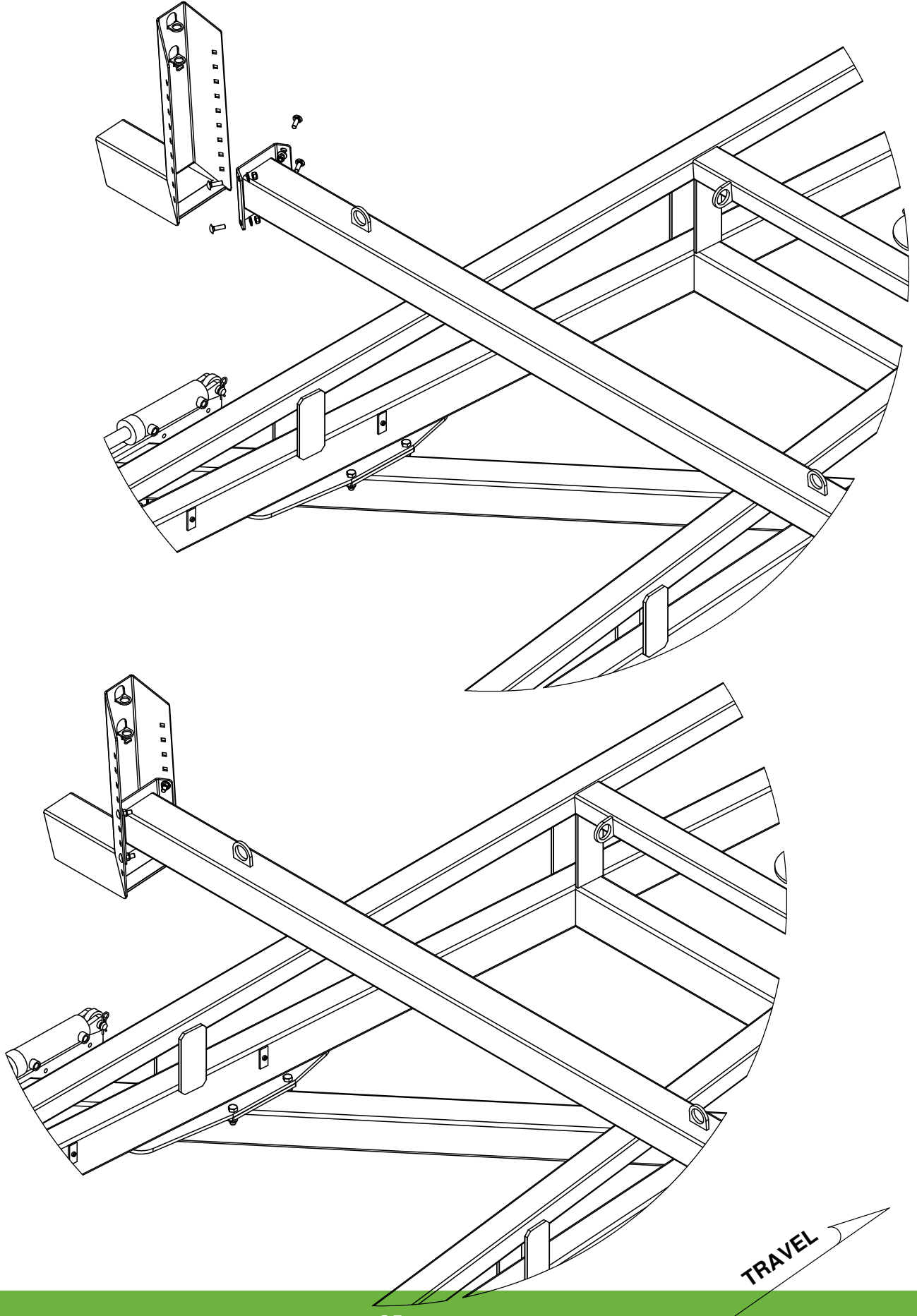

PART NUMBER	DESCRIPTION	QTY.
0800-139.1	Chain Carrier Mount Plate	2
0271-16112104	U-Bolt M16 x 112 x 104	4
0271-16160127	U-Bolt M16 x 160 x 127	4
0231-F12	M12 zp Flat Washer	16
0221-NYL16	M16 Nyloc Nut	16

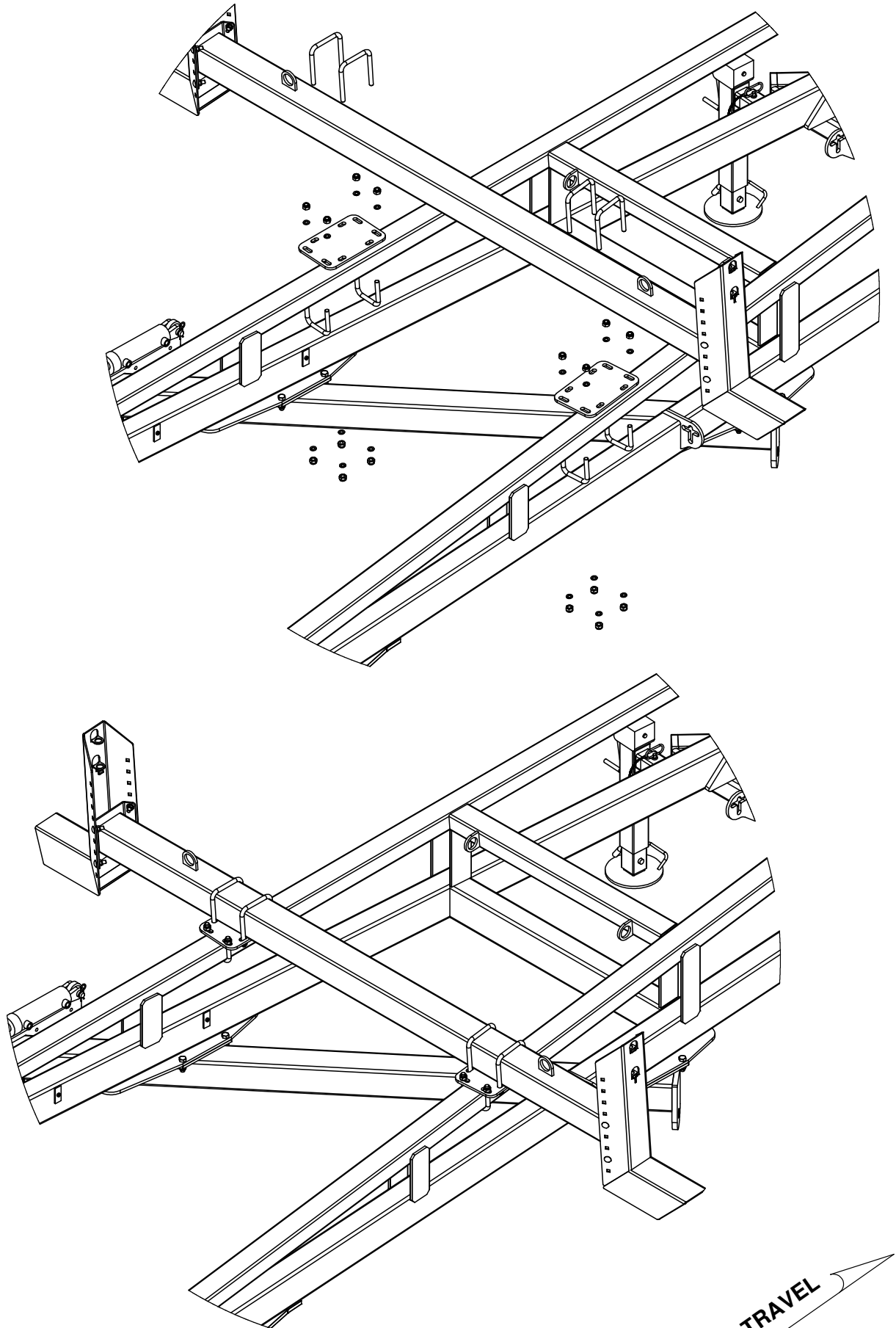

PART NUMBER	DESCRIPTION	QTY.
0810-109R	RH Outrigger With OS Sign Frame	1
0810-109L	LH Outrigger With OS Sign Frame	1
0231-F12	M12 Flat Washer	8
0810-17L	Chain Carrier Bolt on End	2
0211-1650	M16 x 50 8.8 zp Bolt	8
0221-NYL16	M16 Nyloc Nut	8
0221-NYL12	M12 Nyloc Nut	8
0215-CH1240	M12 x 40 Coach Head Bolt	8

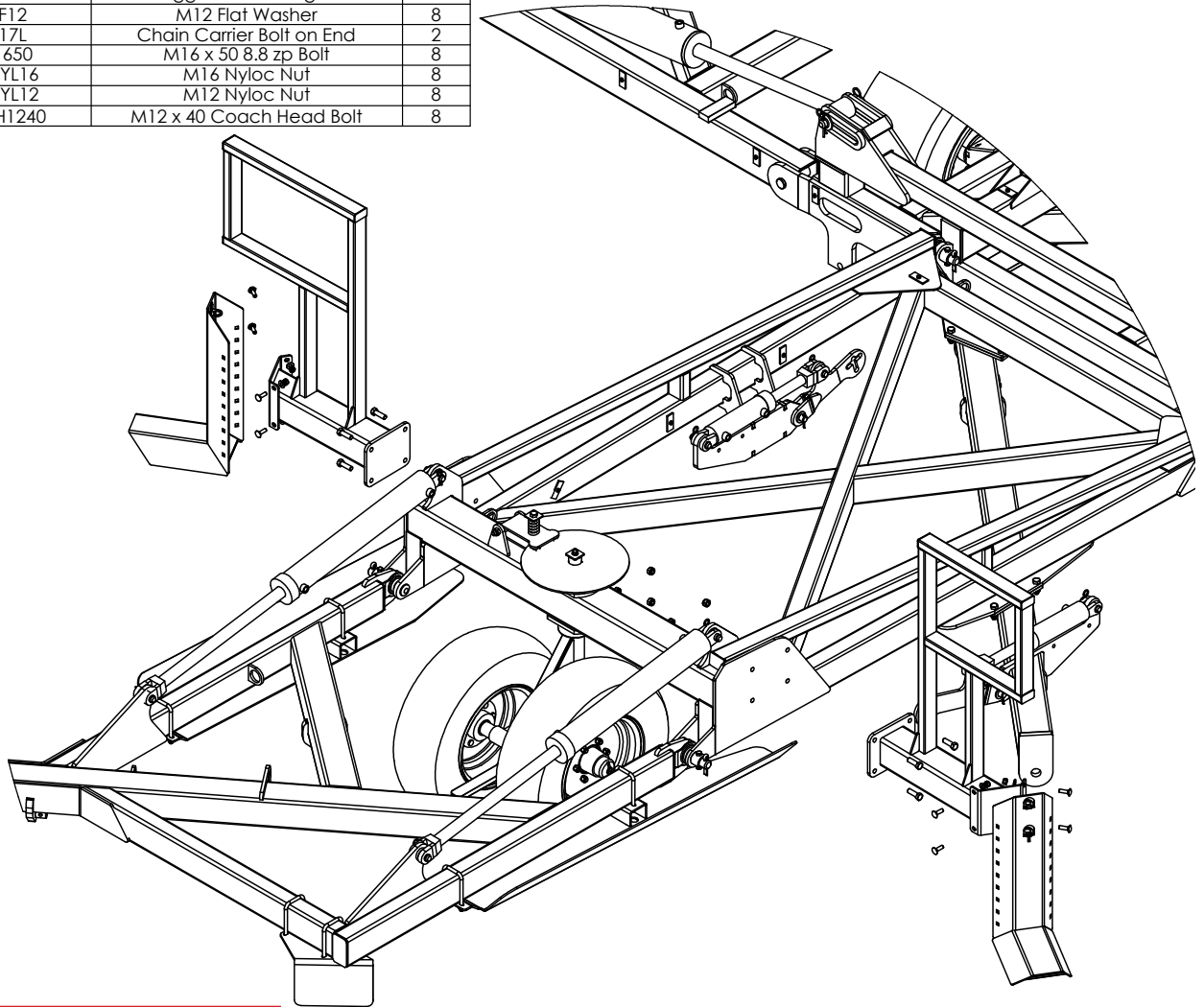

**PLEASE REFER TO
ASSEMBLY
UPDATE 30
IN THE BACK OF
THE MANUAL**

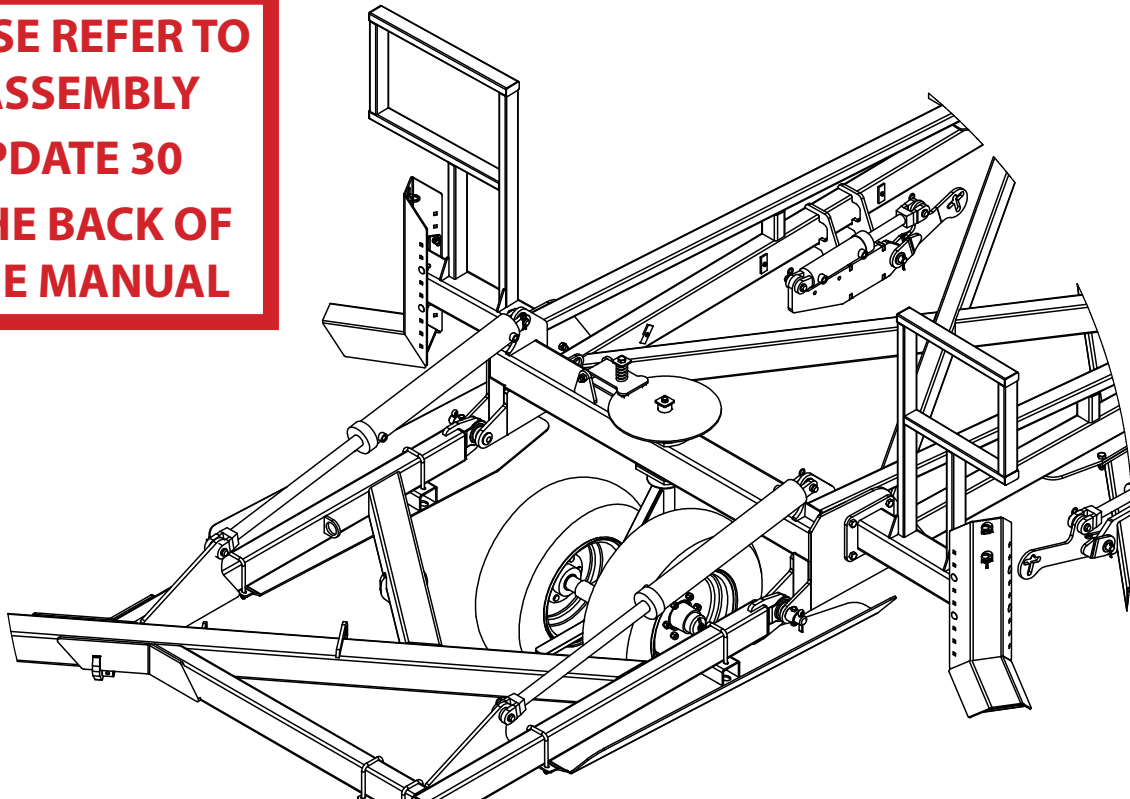

PART NUMBER	DESCRIPTION	QTY.
0801-PS50	50mm Drop Leg Spacer	2
0801-PS25	25mm Drop leg Spacer	4
0810-27	RH Chain Adjusting Lug	1
0810-26	LH Chain Adjusting Lug	1
0810-24	LH Drop Leg	1
0810-25	RH Drop Leg	1
0211-24140	M24 x 140 8.8 zp Bolt	2
0221-NYL24	M24 Nyloc Nut	2
0243-STSG1.25ZP	Poly Spacer clamp Screw	6
0802-PCHB55	20mm Bolt Swivel Unit	2
0802-DCTP-20	Disc Chain Tie Plate Link 20mm	2
0801-PCDCS55	Disc Chain Spacer	2
0211-20110 ST	M20 x 110mm 10.9g Short Thread	6
0221-NYL20	M20 Nyloc Nut	6

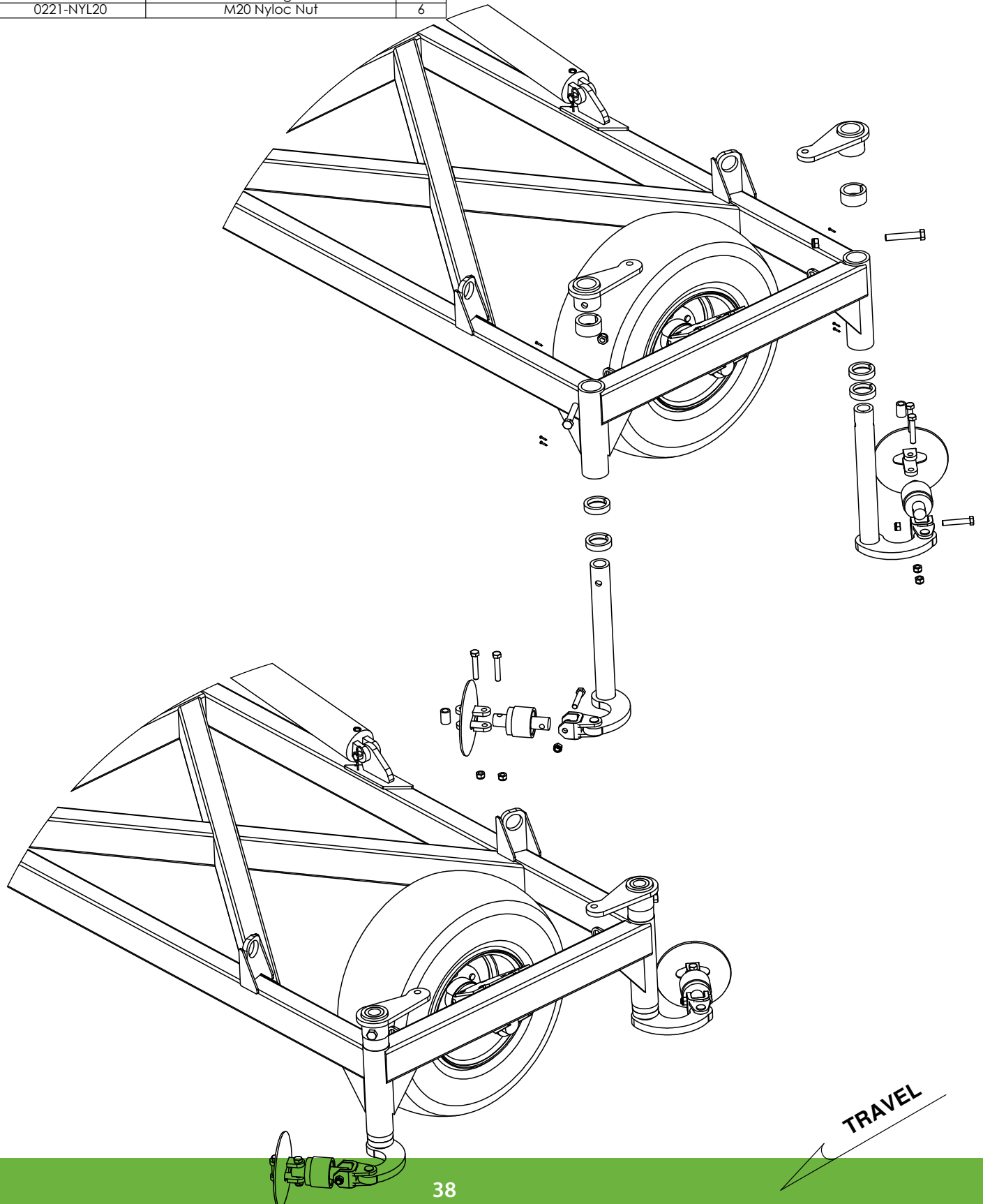

PART NUMBER	DESCRIPTION	QTY.
0801-KE-0307-1	Clevis Pin 25mm x 75mm	2
0801-XK9261S	20mm Compression Spring	2
0801-KE0805-3	Tensioner Cup Male	2
0801-KE0805-4	Tensioner Cup Female	2
0801-PCHTA-B6	6tpi 1.25" Tension Bolt	2
0801-PCHTA-BC	Tension Assembly Body	2
0801-PCHTA-N6	6tpi Lock Nut	6
0801-PCHTA-SB	Steel Spring Retaining Bush	2
0261-PINC550	Cotter Pin M5 x 50	2

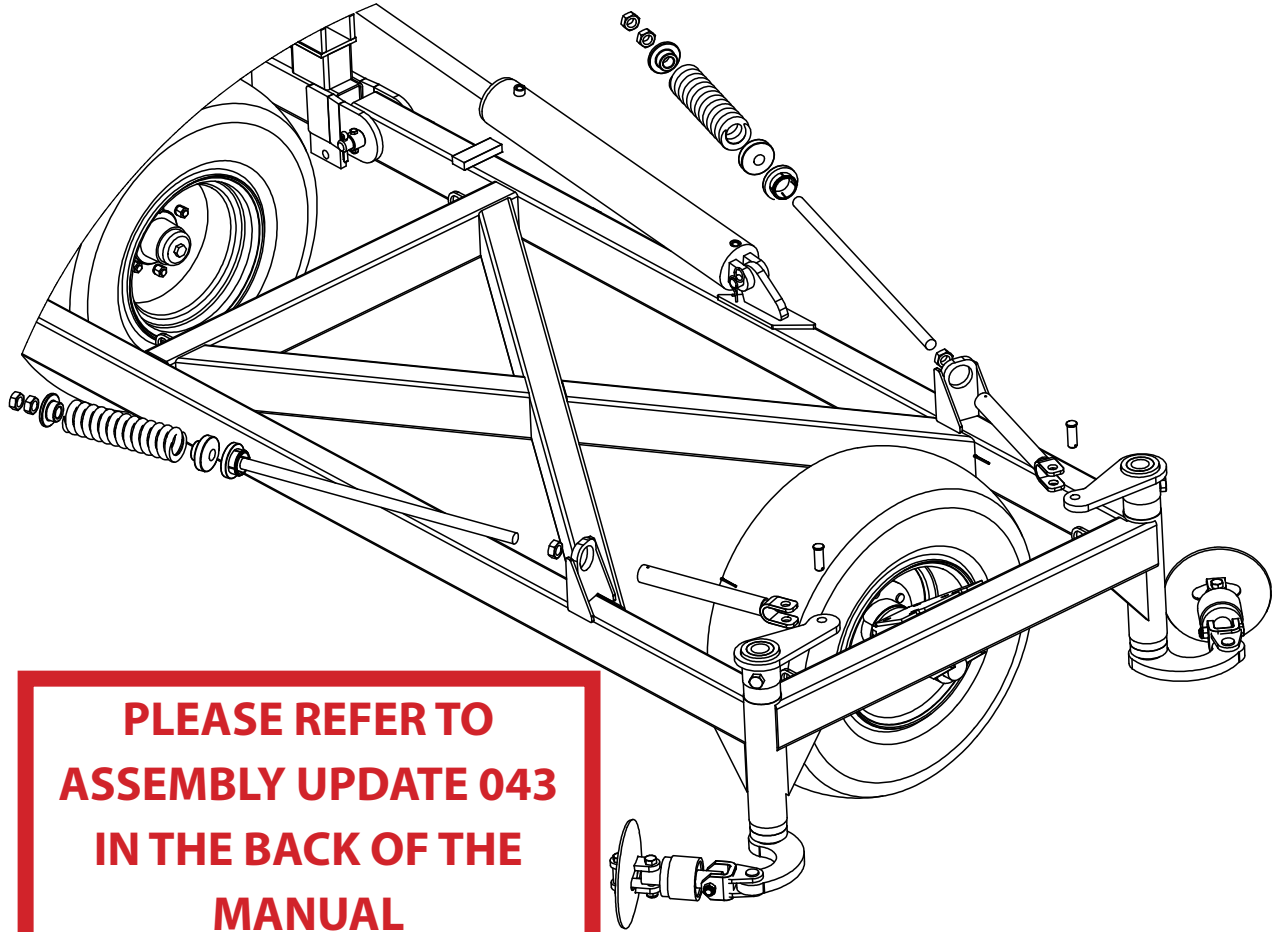

**PLEASE REFER TO
ASSEMBLY UPDATE 043
IN THE BACK OF THE
MANUAL**

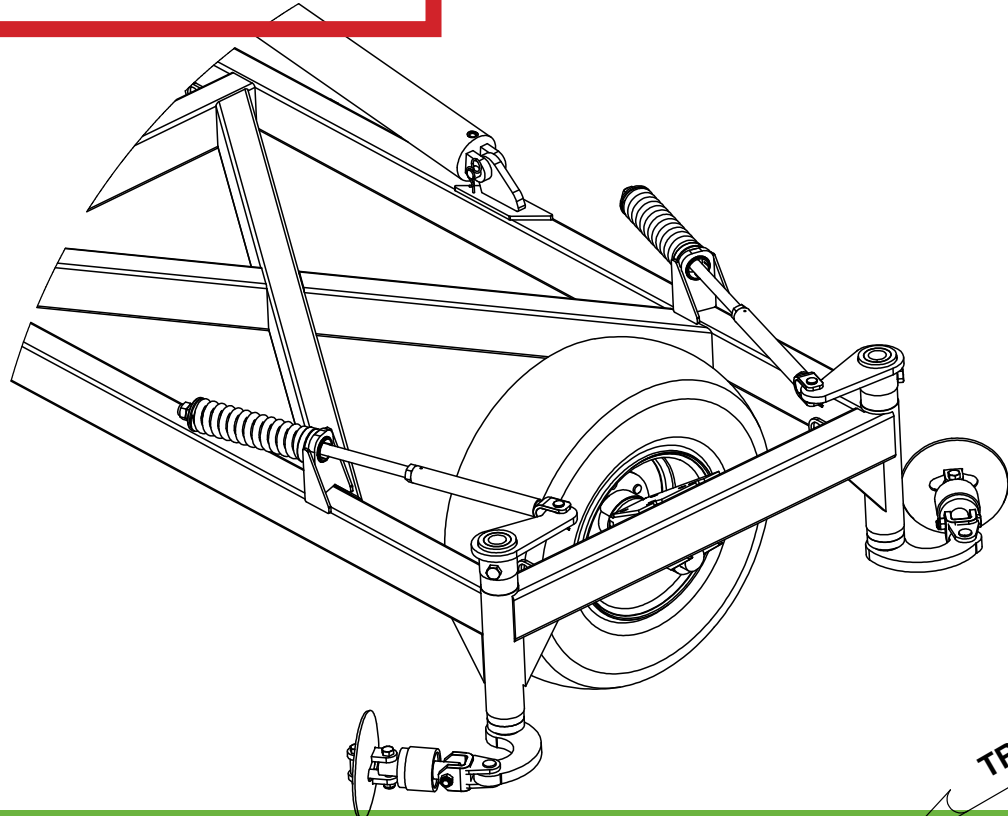

TRAVEL

PART NUMBER	DESCRIPTION	QTY.
0801-PS50	50mm Drop Leg Spacer	2
0801-PS25	25mm Drop leg Spacer	4
0810-27	RH Chain Adjusting Lug	1
0810-26	LH Chain Adjusting Lug	1
0810-24	LH Drop Leg	1
0810-25	RH Drop Leg	1
0243-ST8G1.25ZP	Poly Spacer clamp Screw	6
0802-PCHB55	20mm Bolt Swivel Unit	2
0802-DCTP-20	Disc Chain Tie Plate Link 20mm	2
0801-PCDCS55	Disc Chain Spacer	2
0211-24140	M24 x 140 8.8 zp Bolt	2
0221-NYL24	M24 Nyloc Nut	2
0211-20110 ST	M20 x 110mm 10.9g Short Thread	6
0221-NYL20	M20 Nyloc Nut	6

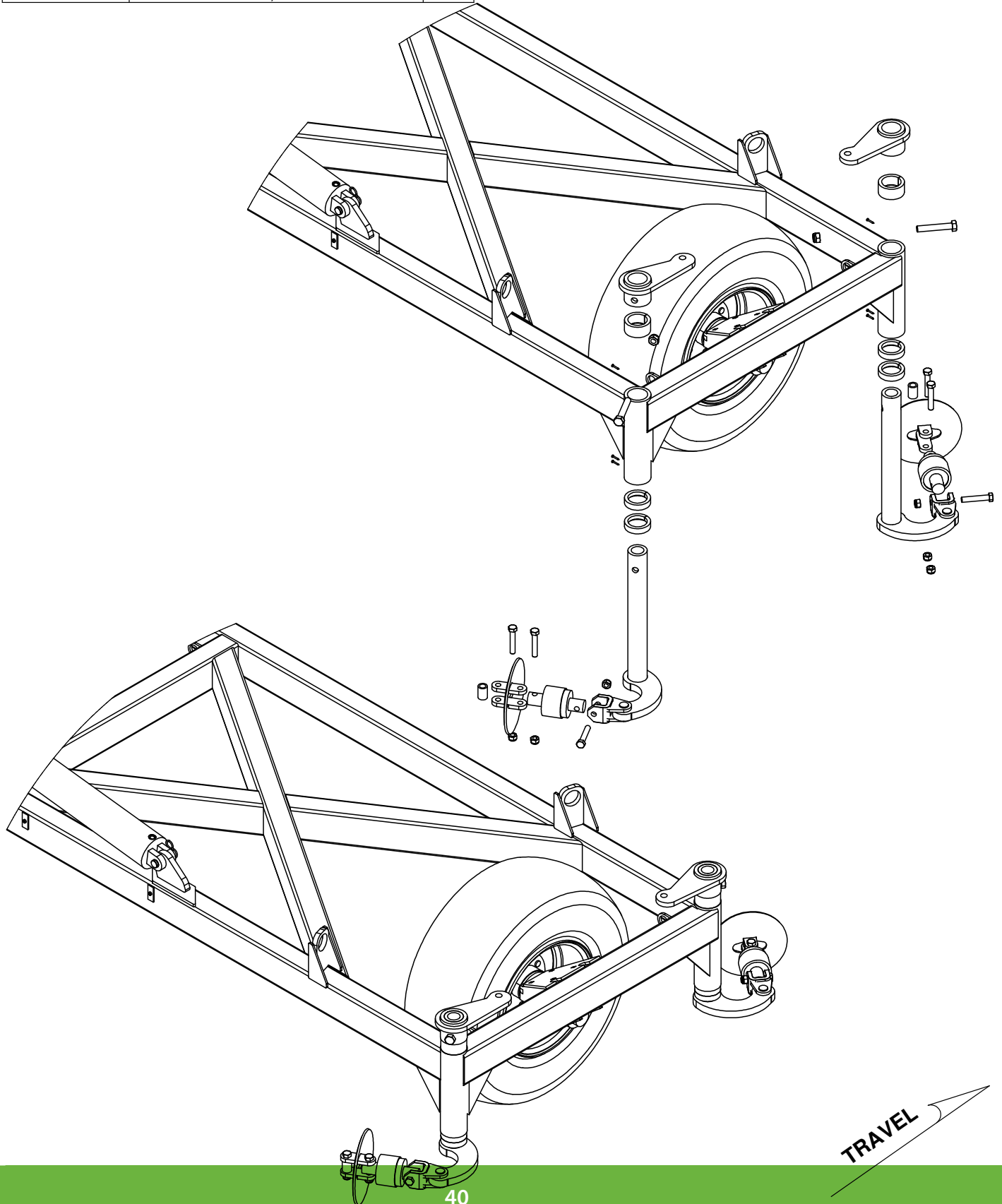

PART NUMBER	DESCRIPTION	QTY.
0801-KE-0307-1	Clevis Pin 25mm x 75mm	2
0801-XK9261S	20mm Compression Spring	2
0801-KE0805-3	Tensioner Cup Male	2
0801-KE0805-4	Tensioner Cup Female	2
0801-PCHTA-B6	6tpi 1.25" Tension Bolt	2
0801-PCHTA-BC	Tension Assembly Body	2
0801-PCHTA-N6	6tpi Lock Nut	6
0801-PCHTA-SB	Steel Spring Retaining Bush	2
0261-PINC550	Cotter Pin M5 x 50	2

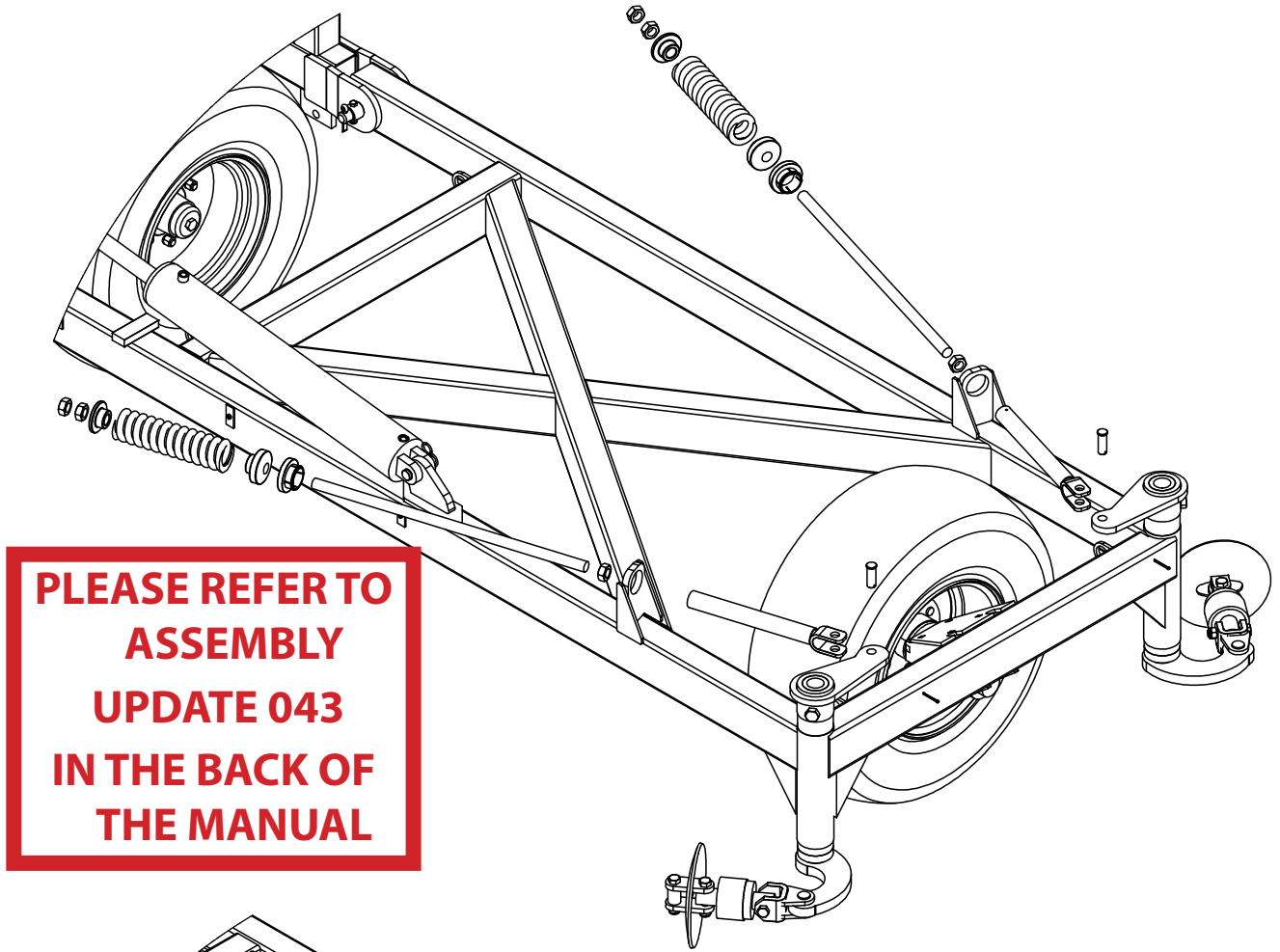

**PLEASE REFER TO
ASSEMBLY
UPDATE 043
IN THE BACK OF
THE MANUAL**

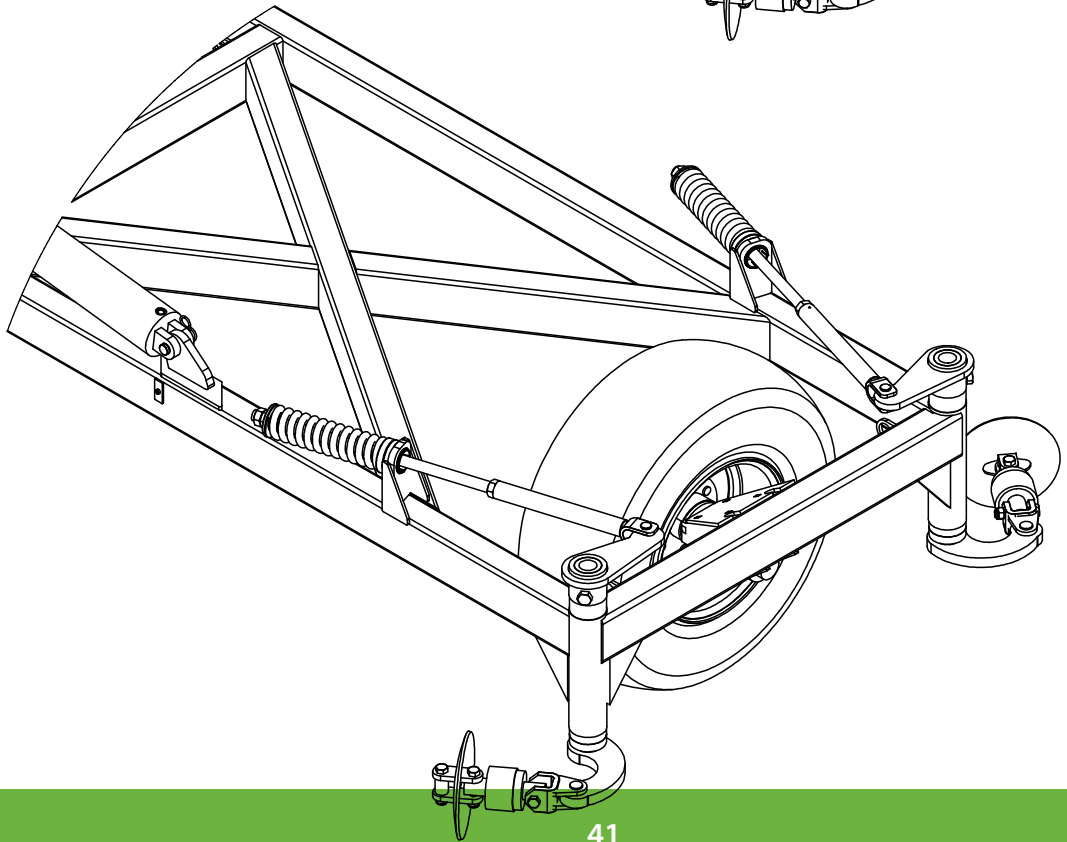

TRAVEL

PART NUMBER	DESCRIPTION	QTY.
0802-PCHB55	20mm Bolt Swivel Unit	2
0802-DCTP-20	Disc Chain Tie Plate Link 20mm	2
0801-PCDCS55	Disc Chain Spacer	2
0810-20	Chain Mount Arm	2
0801-10-51	Chain Mount Pin	2
0801-PCH24MCA	Height Adjusting Chain	2
0232-HT13-8	Washer High Tensile 1 3/8"	2
0211-1265	M12 x 65 8.8 zp Bolt	2
0221-NYL12	M12 Nyloc Nut	2
0211-20110 ST	M20 x 110mm 10.9g Short Thread	6
0221-NYL20	M20 Nyloc Nut	6
0231-S20	M20 zp Spring Washer	2
0211-2050	M20 x 50 8.8 zp Bolt	2

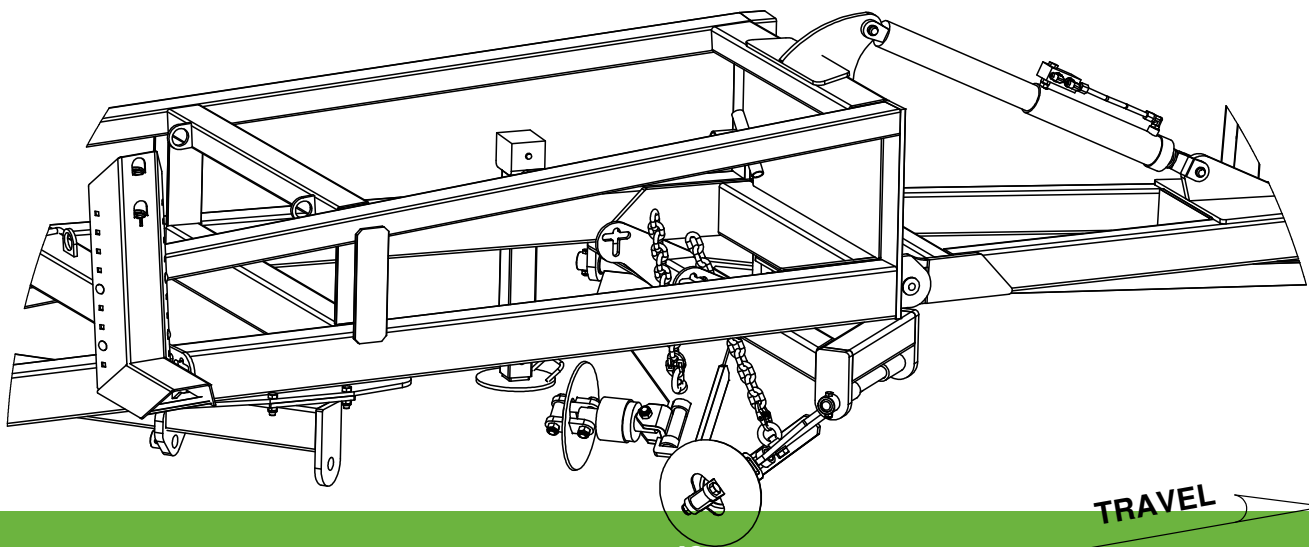
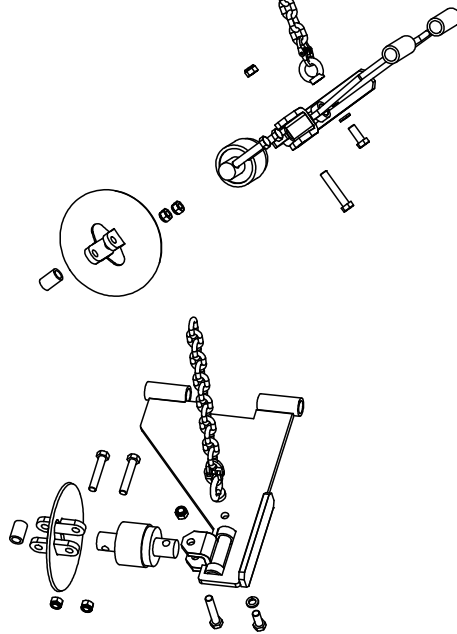
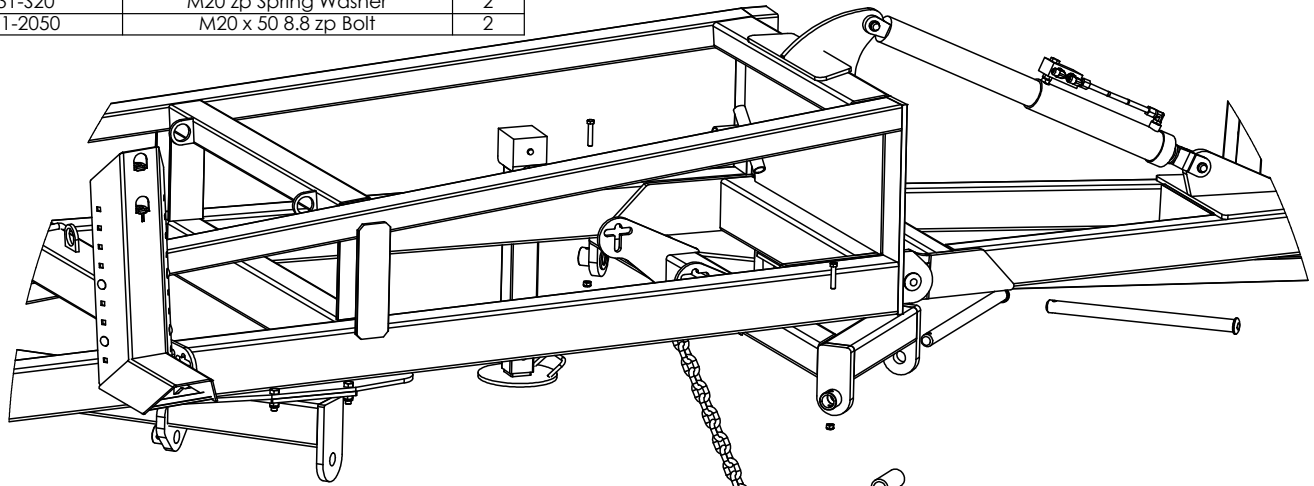

PART NUMBER	DESCRIPTION	QTY.
0802-PCHB55	20mm Bolt Swivel Unit	1
0802-DCTP-20	Disc Chain Tie Plate Link 20mm	1
0801-PCDCS55	Disc Chain Spacer	1
0810-20	Chain Mount Arm	1
0801-10-51	Chain Mount Pin	1
0801-PCH24MCA	Height Adjusting Chain	1
0232-HT13-8	Washer High Tensile 1 3/8"	1
0231-S20	M20 zp Spring Washer	1
0211-1265	M12 x 65 8.8 zp Bolt	1
0221-NYL12	M12 Nyloc Nut	1
0211-20110 ST	M20 x 110mm 10.9g Short Thread	3
0221-NYL20	M20 Nyloc Nut	3
0211-2050	M20 x 50 8.8 zp Bolt	1

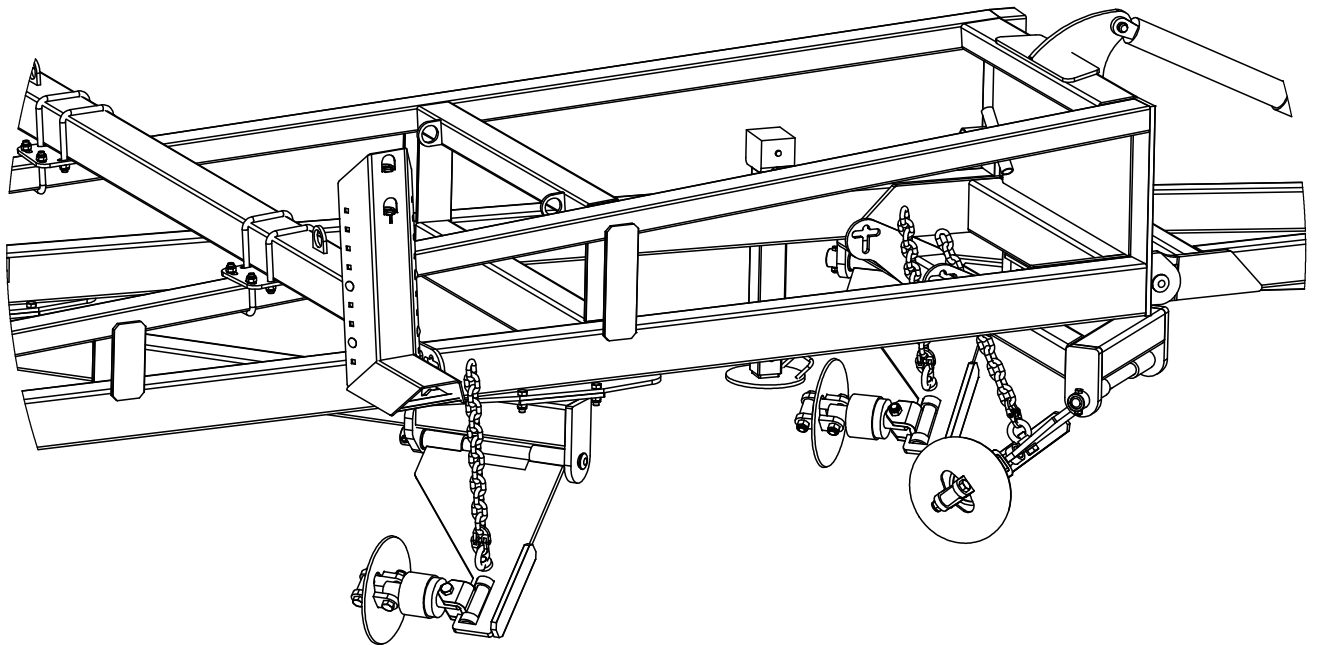
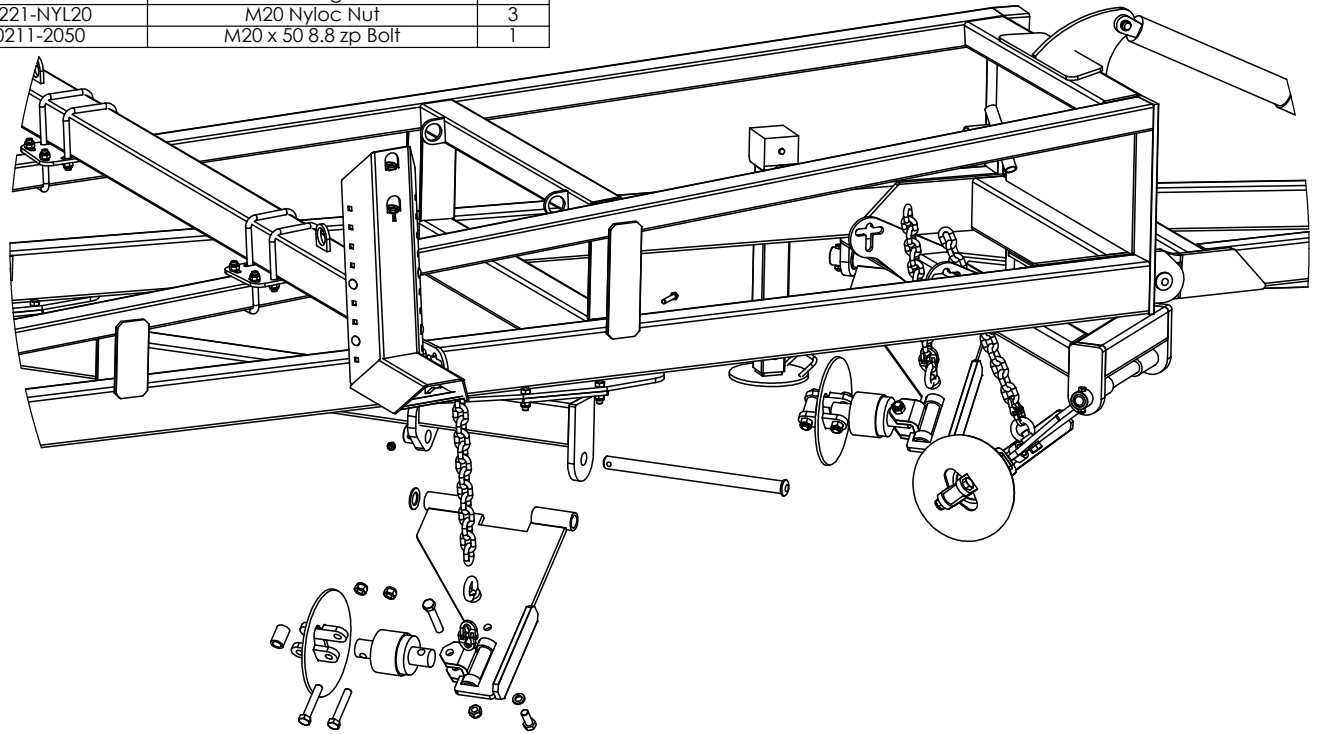

TRAVEL

PART NUMBER	DESCRIPTION	QTY.
0802-PCHB55	20mm Bolt Swivel Unit	1
0802-DCTP-20	Disc Chain Tie Plate Link 20mm	1
0801-PCDCS55	Disc Chain Spacer	1
0801-10-51	Chain Mount Pin	1
0801-PCH24MCA	Height Adjusting Chain	1
0232-HT13-8	Washer High Tensile 1 3/8"	1
0231-S20	M20 zp Spring Washer	1
0810-33	Reducing Chain Mount Arm 20mm Clevis	1
0211-1265	M12 x 65 8.8 zp Bolt	1
0221-NYL12	M12 Nyloc Nut	1
0211-2050	M20 x 50 8.8 zp Bolt	1
0211-20110 ST	M20 x 110mm 10.9g Short Thread	3
0221-NYL20	M20 Nyloc Nut	3

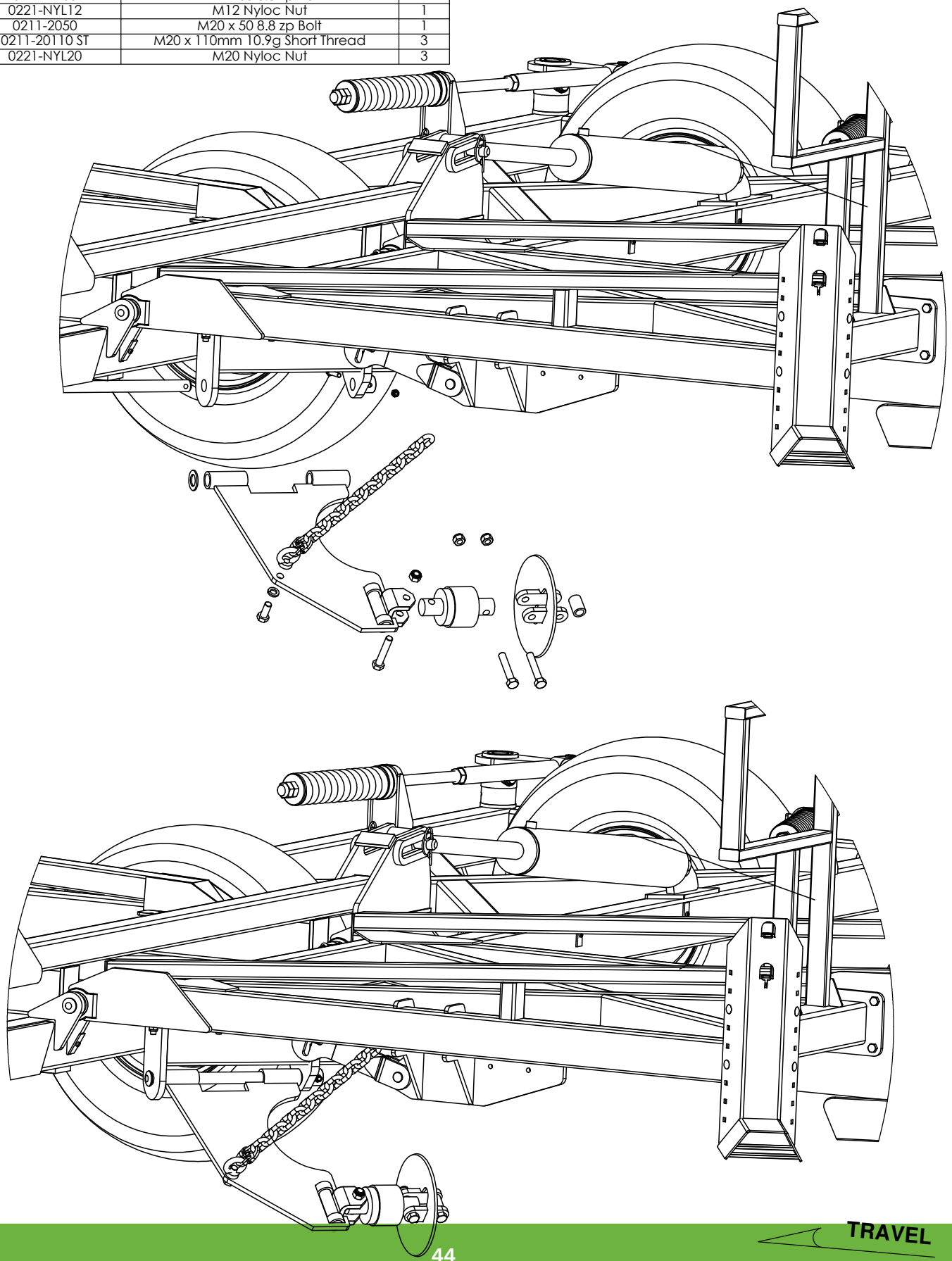

PART NUMBER	DESCRIPTION	QTY.
0802-PCHB55	20mm Bolt Swivel Unit	2
0802-DCTP-20	Disc Chain Tie Plate Link 20mm	2
0801-PCDCS55	Disc Chain Spacer	2
0810-20	Chain Mount Arm	2
0801-10-51	Chain Mount Pin	2
0801-PCH24MCA	Height Adjusting Chain	2
0232-HT13-8	Washer High Tensile 1 3/8"	2
0231-S20	M20 zp Spring Washer	2
0211-2050	M20 x 50 8.8 zp Bolt	2
0211-1265	M12 x 65 8.8 zp Bolt	2
0221-NYL12	M12 Nyloc Nut	2
0211-20110 ST	M20 x 110mm 10.9g Short Thread	6
0221-NYL20	M20 Nyloc Nut	6

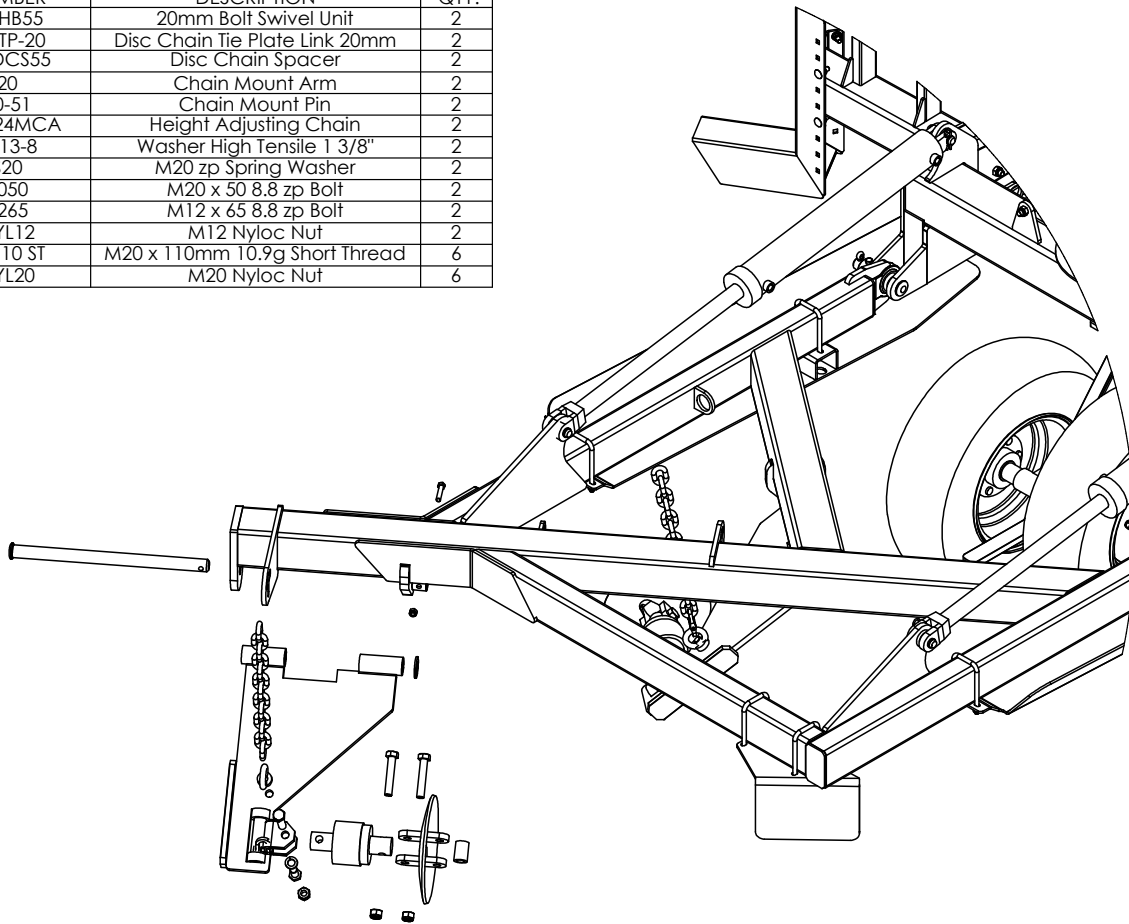

**PLEASE REFER TO ASSEMBLY UPDATE 043
IN THE BACK OF THE MANUAL**

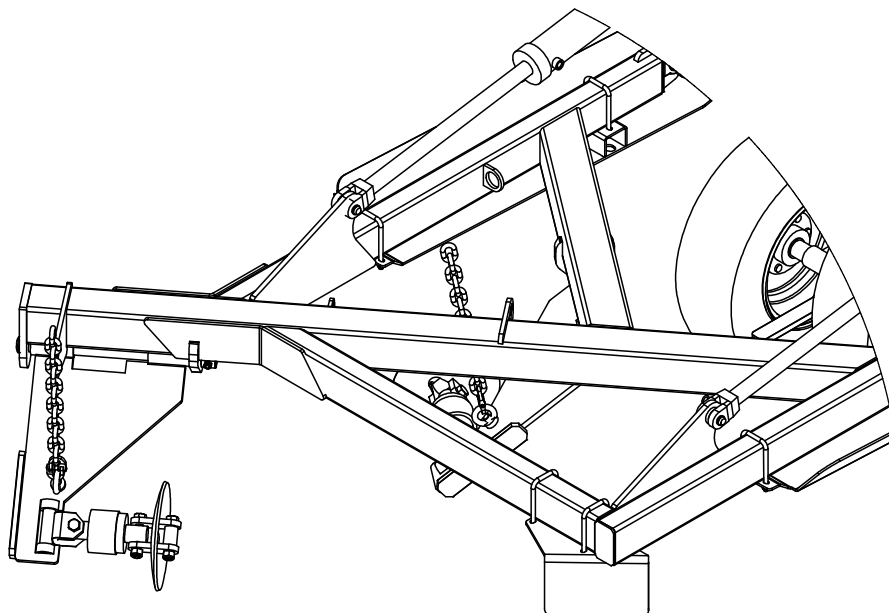

PART NUMBER	DESCRIPTION	QTY.
0113-MB 3550DX	35 ID x 50mm DX Bush	2
0801-KE-0307-1	Clevis Pin 25mm x 75mm	1
0802-PCHB55	20mm Bolt Swivel Unit	1
0802-DCTP-20	Disc Chain Tie Plate Link 20mm	1
0801-PCDCS55	Disc Chain Spacer	1
0801-XK9261S	20mm Compression Spring	1
0801-PCHTA-N6	6tpi Lock Nut	2
0801-PCHTA-SB	Steel Spring Retaining Bush	1
0801-10-51	Chain Mount Pin	1
0232-HT13-8	Washer High Tensile 1 3/8"	1
0231-S20	M20 zp Spring Washer	1
0810-103F	Front Module Tension Body	1
0211-1265	M12 x 65 8.8 zp Bolt	1
0221-NYL12	M12 Nyloc Nut	1
0801-PCH24MCA	Height Adjusting Chain	1
0810-104-40-45	40/45° Module Tension Arm	1
0810-105	Module Tension Linkage	1
0801-10-110	Module Pivot Arm Bush	1
0801-10-S2L	Rigid Spring Locator	1
0211-20110 ST	M20 x 110mm 10.9g Short Thread	3
0221-NYL20	M20 Nyloc Nut	4
0211-2050	M20 x 50 8.8 zp Bolt	1
0211-20150	M20 x 150 8.8 zp Bolt	1
0261-PINC550	Cotter Pin M5 x 50	1

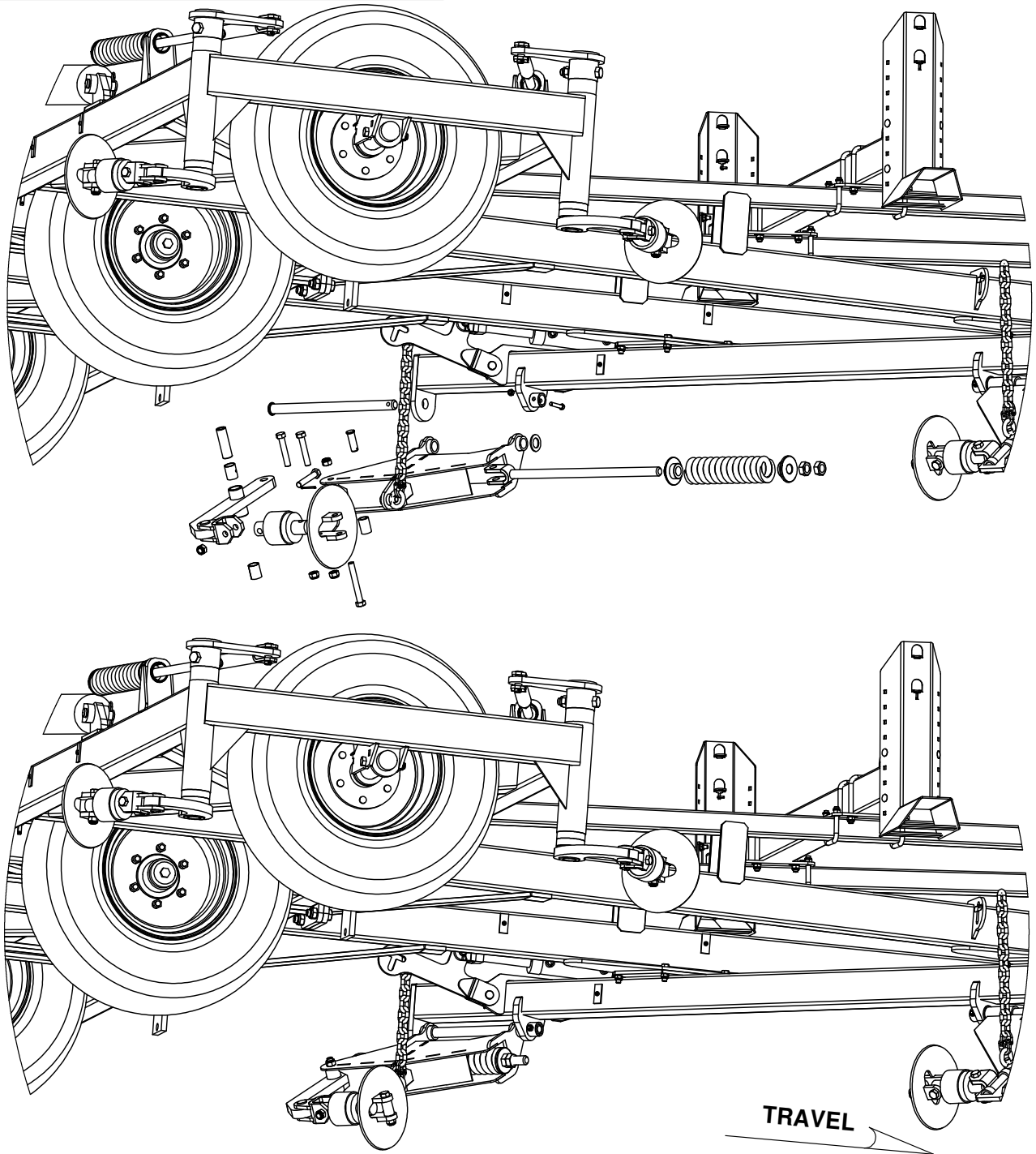

PART NUMBER	DESCRIPTION	QTY.
0113-MB 3550DX	35 ID x 50mm DX Bush	2
0801-KE-0307-1	Clevis Pin 25mm x 75mm	1
0802-PCHB55	20mm Bolt Swivel Unit	1
0802-DCTP-20	Disc Chain Tie Plate Link 20mm	1
0801-PCDCS55	Disc Chain Spacer	1
0801-XK9261S	20mm Compression Spring	1
0801-PCHTA-N6	6tpi Lock Nut	2
0801-PCHTA-SB	Steel Spring Retaining Bush	1
0801-10-51	Chain Mount Pin	1
0232-HT13-8	Washer High Tensile 1 3/8"	1
0231-S20	M20 zp Spring Washer	1
0801-PCH24MCA	Height Adjusting Chain	1
0810-104-40-45	40/45° Module Tension Arm	1
0810-105	Module Tension Linkage	1
0801-10-110	Module Pivot Arm Bush	1
0801-10-S2L	Rigid Spring Locator	1
0810-103R	Rear Module Tension Body	1
0211-1265	M12 x 65 8.8 zp Bolt	1
0221-NYL12	M12 Nyloc Nut	1
0211-20150	M20 x 150 8.8 zp Bolt	1
0221-NYL20	M20 Nyloc Nut	4
0211-2050	M20 x 50 8.8 zp Bolt	1
0211-20110 ST	M20 x 110mm 10.9g Short Thread	3
0261-PINC550	Cotter Pin M5 x 50	1

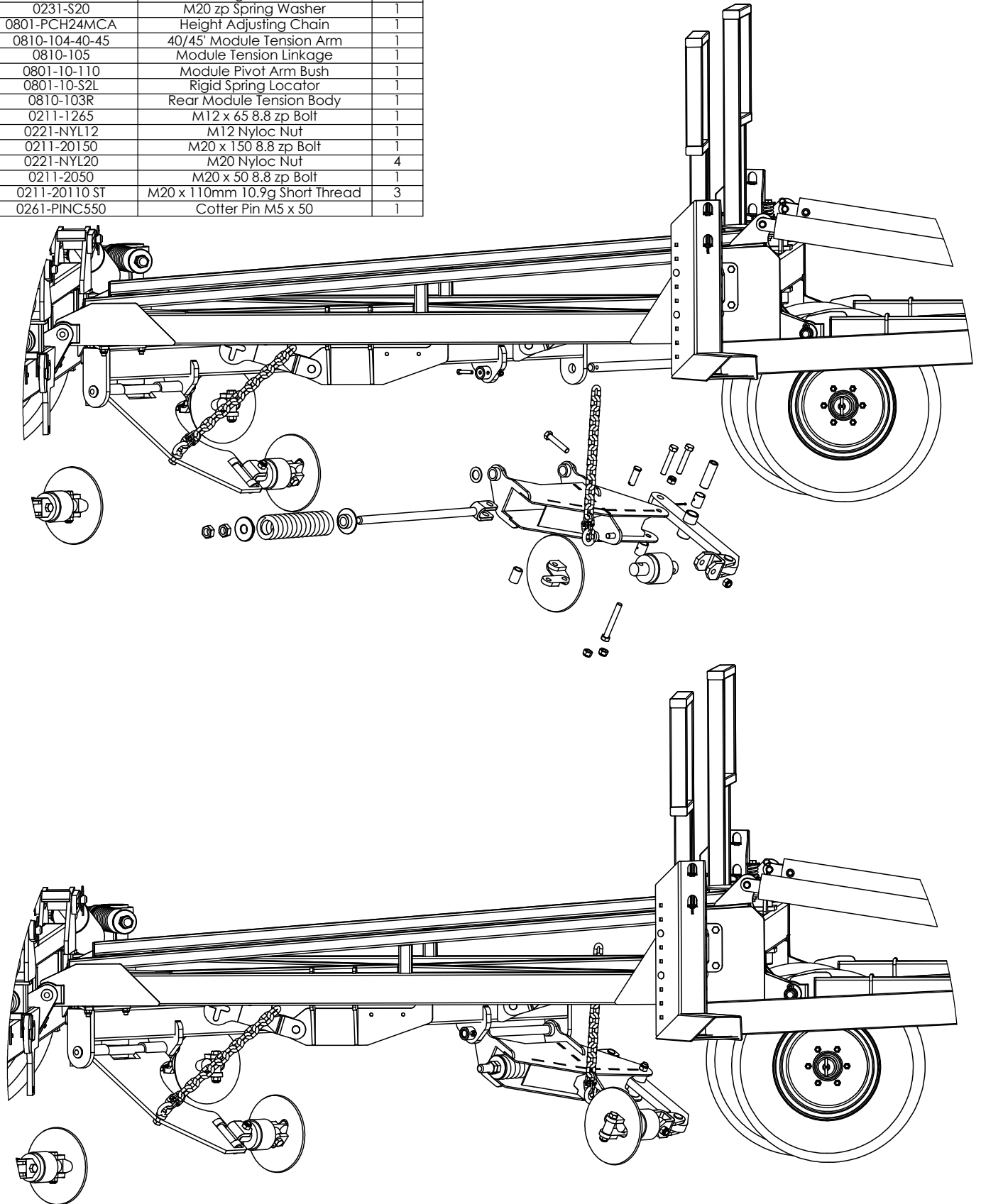

Section 3

Diagrams and charts

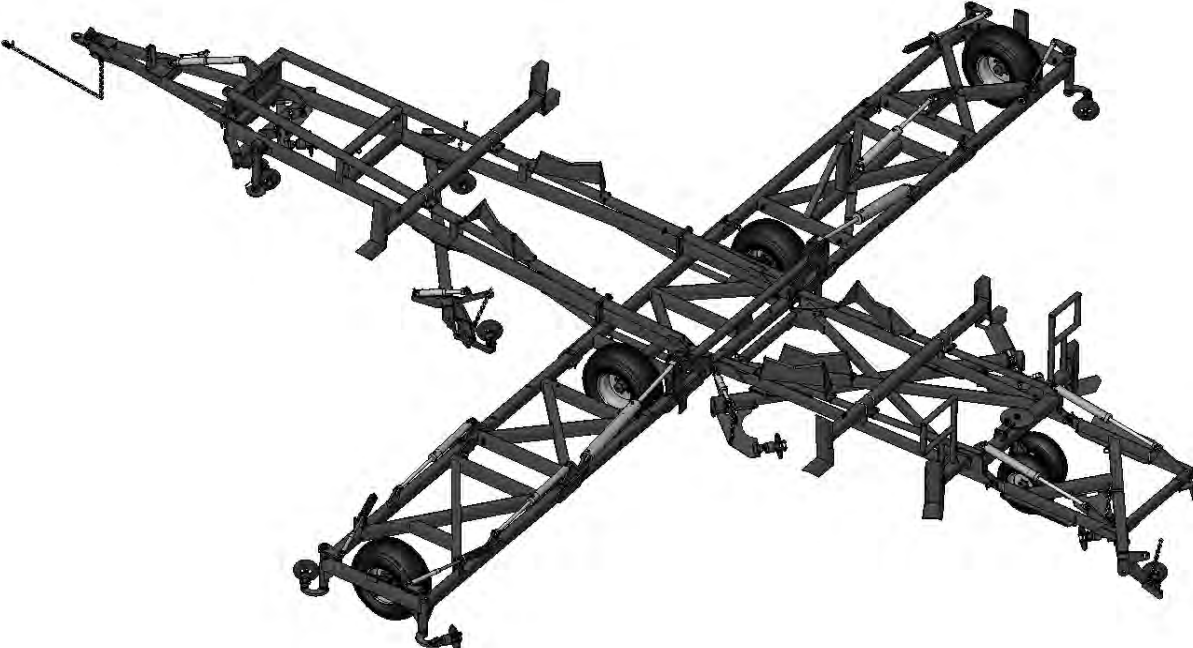
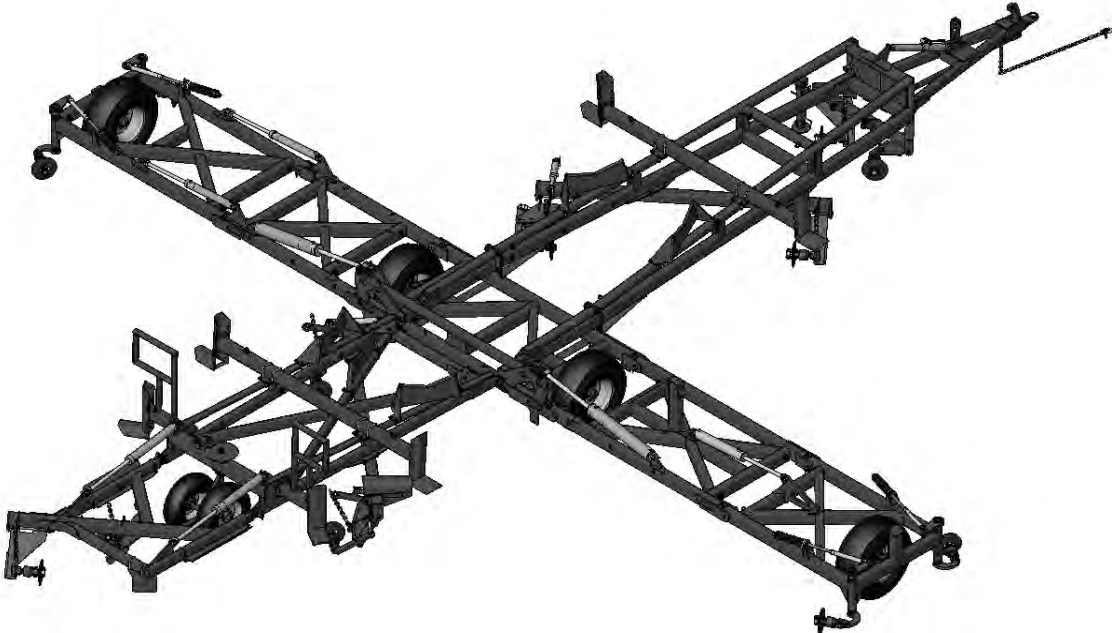

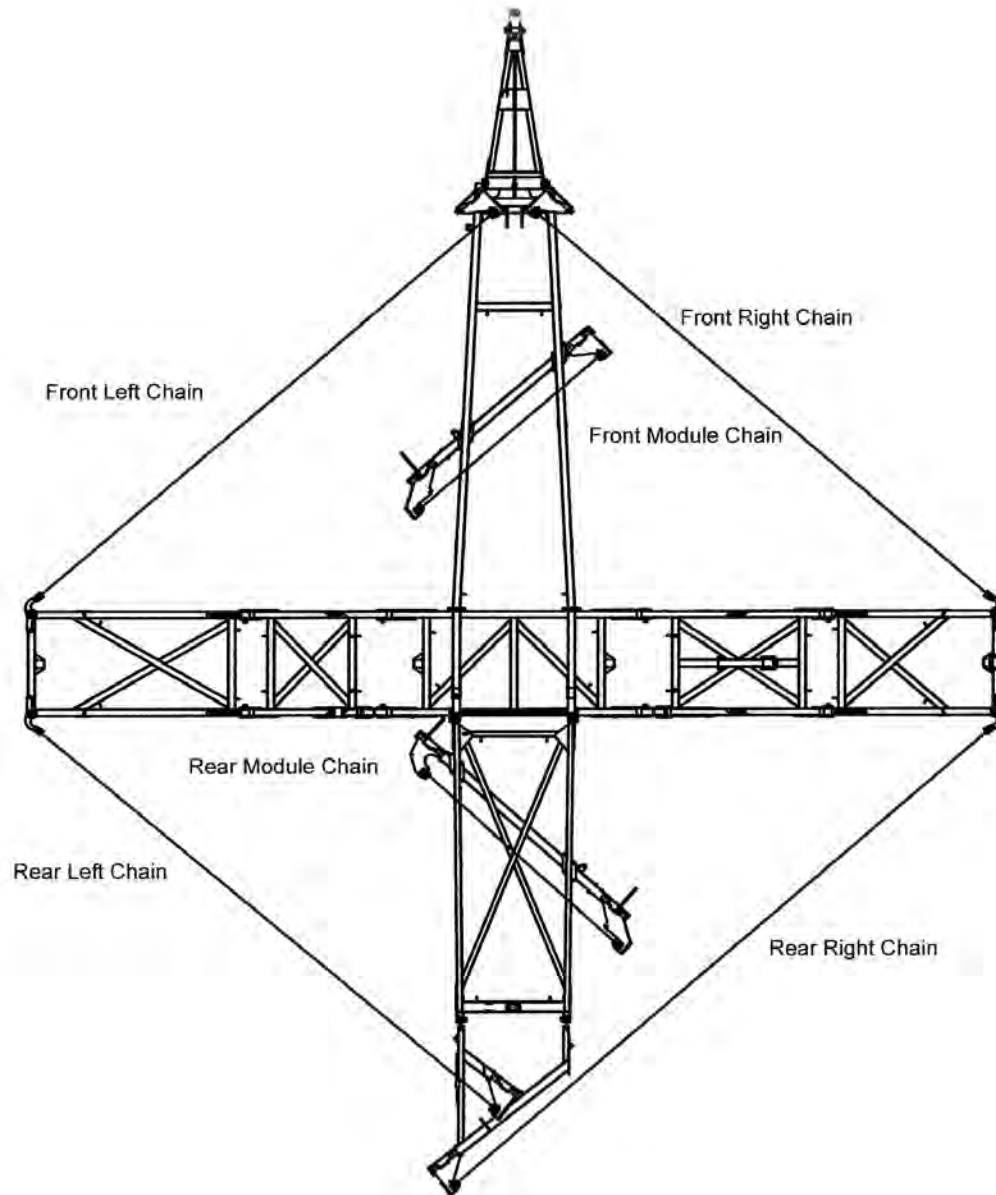



Before folding the machine for the first time, ensure all hydraulic cylinders are charged with oil.

To do this, run the hydraulics through the unfold sequence until the outer wings are straight and the centre cylinders are centered in the slots. (It may take a few minutes for the cylinders to charge completely).

Failure to do this could result in severe personal injury and/or damage to the machine.

Cylinders NOT charged

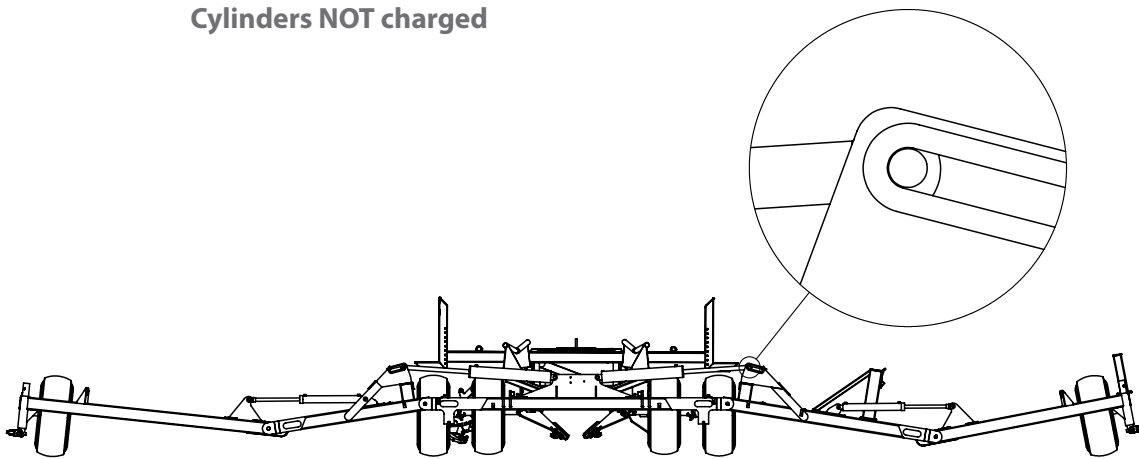

Cylinders charged

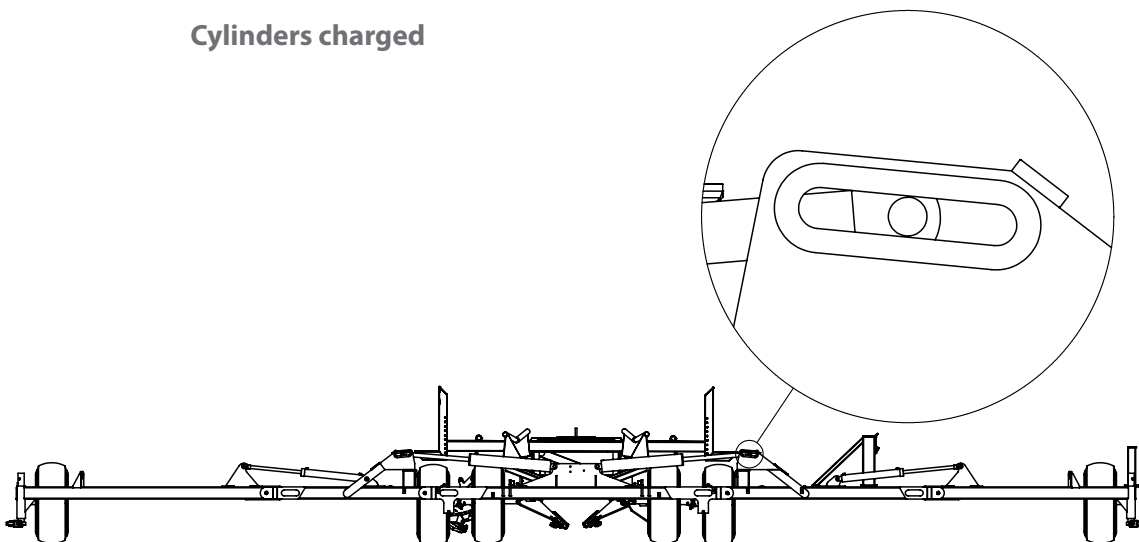

Hydraulic fitting identification

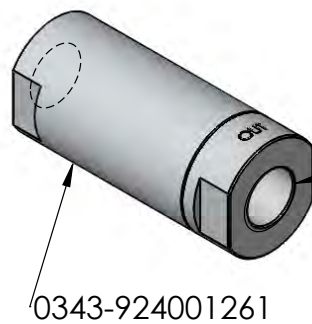
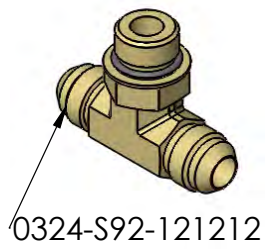
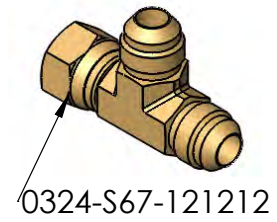
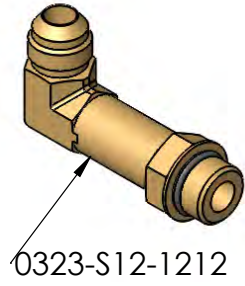

Note: Fit this end to valve block

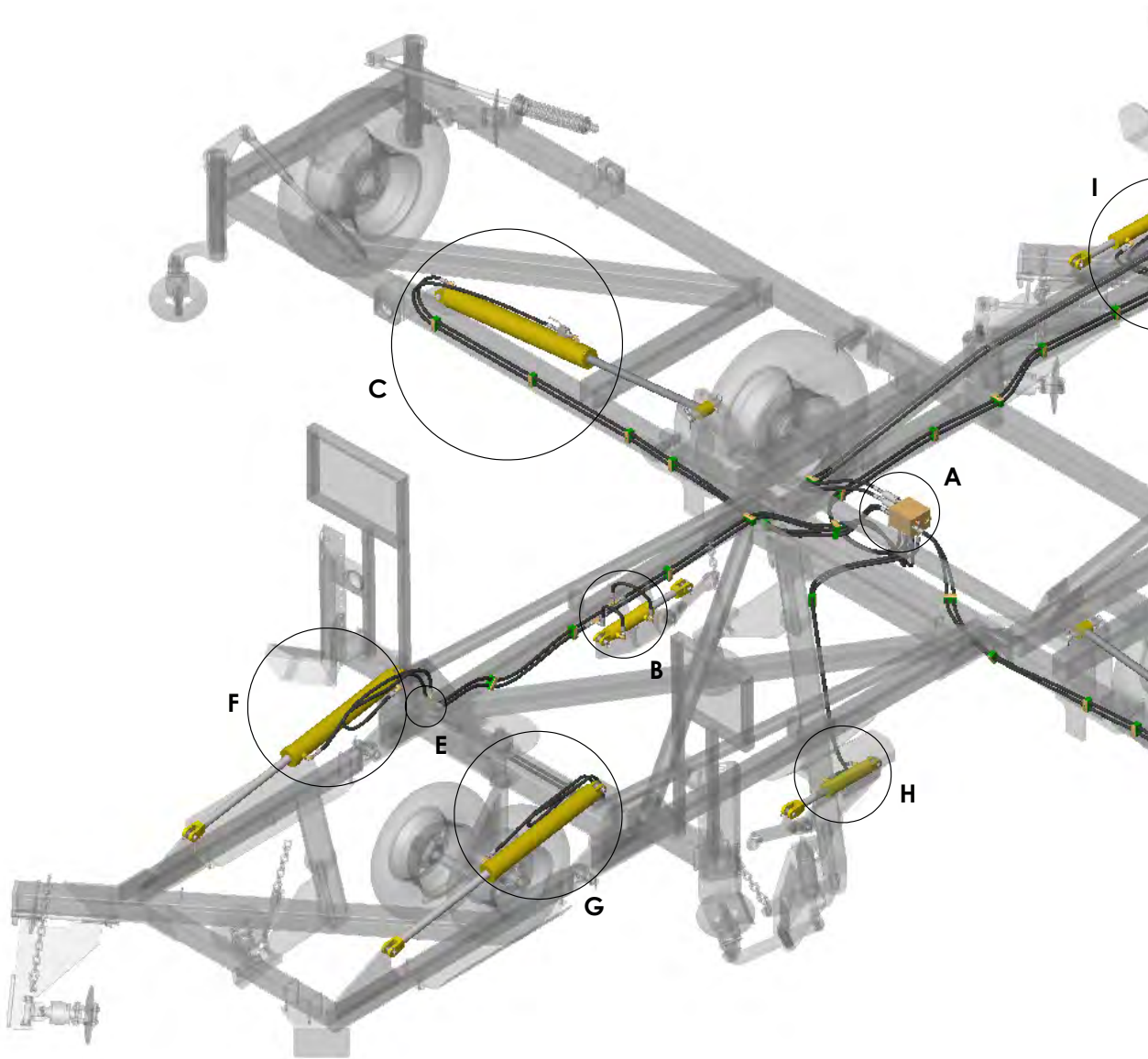

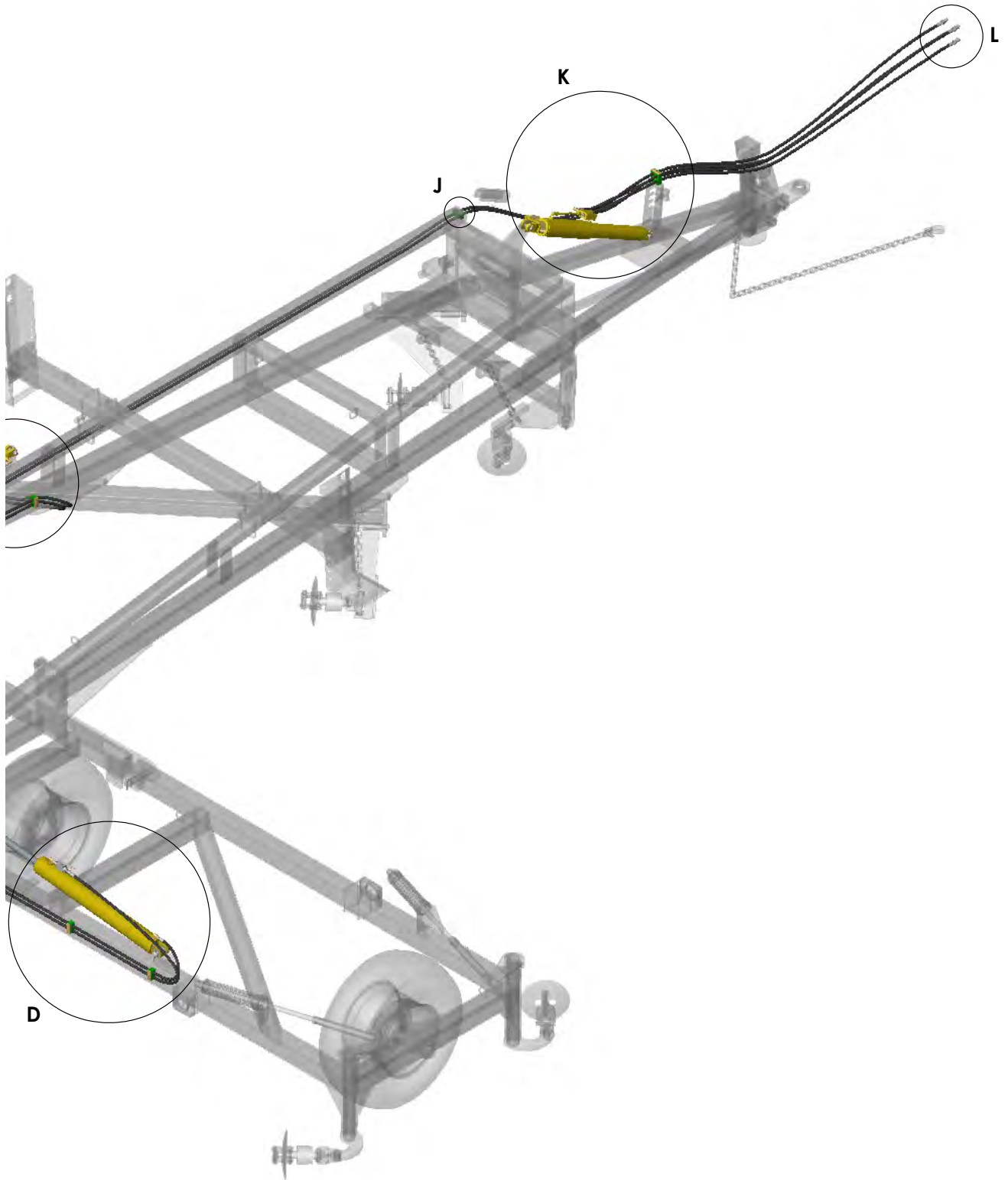

**PLEASE REFER TO ASSEMBLY UPDATE 20 & 36
IN THE BACK OF THE MANUAL**

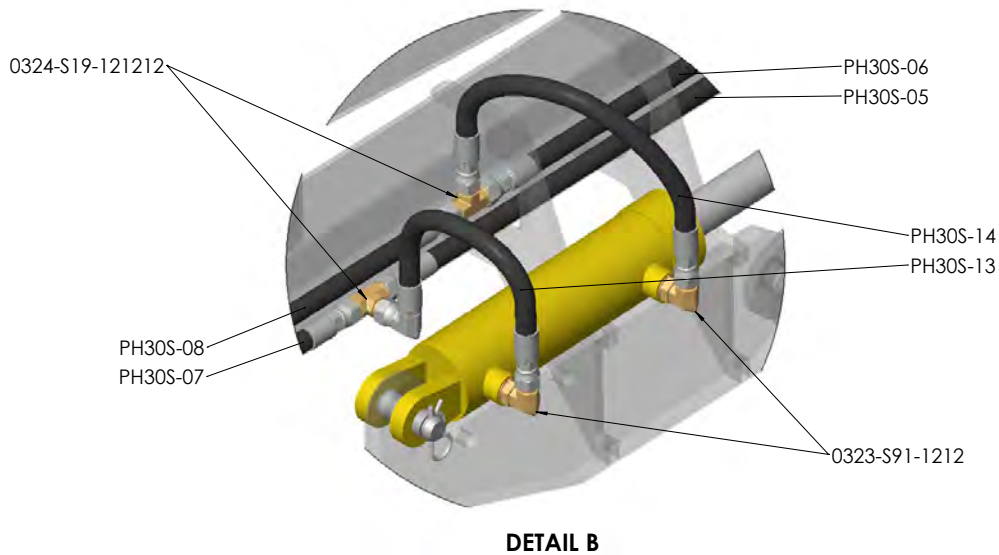
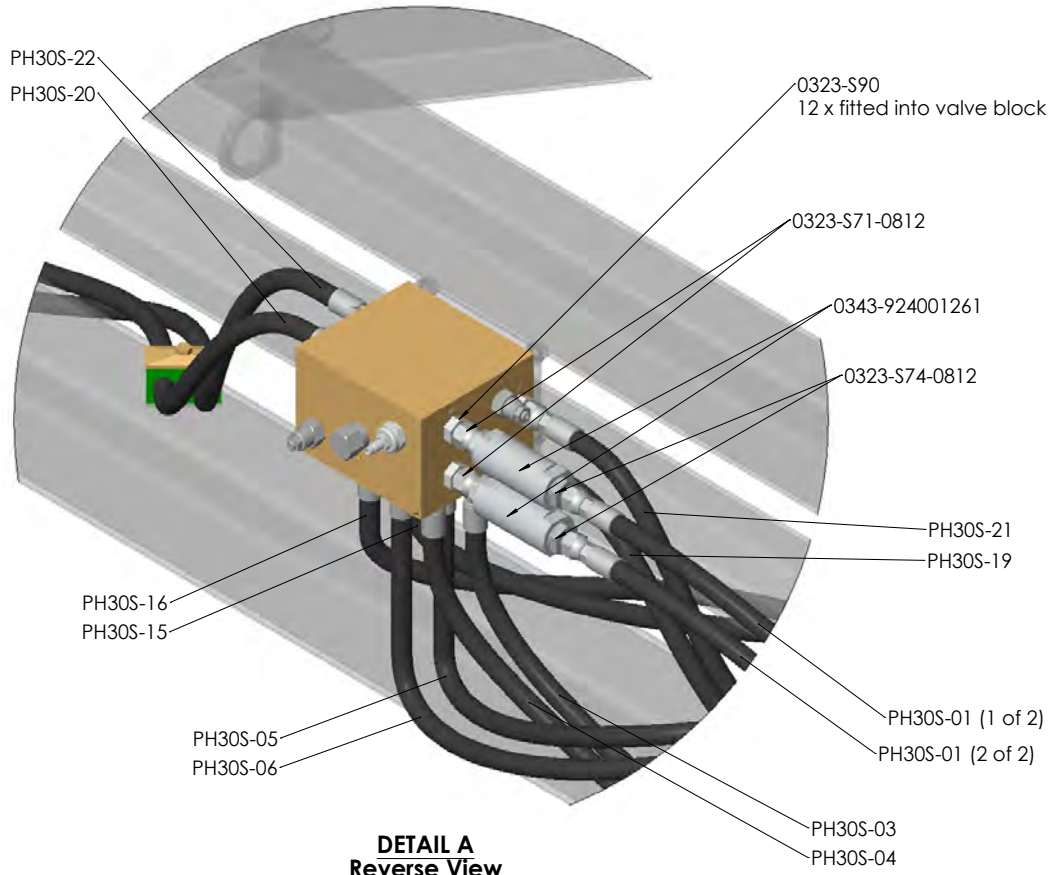

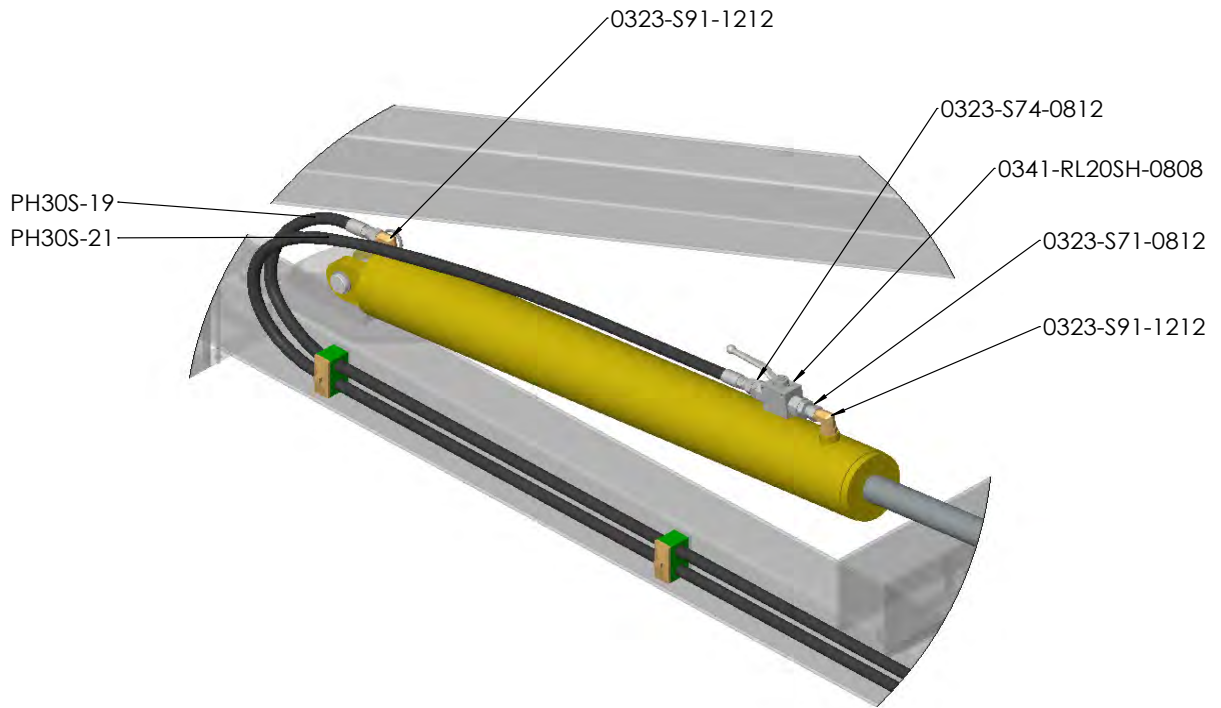

DETAIL C

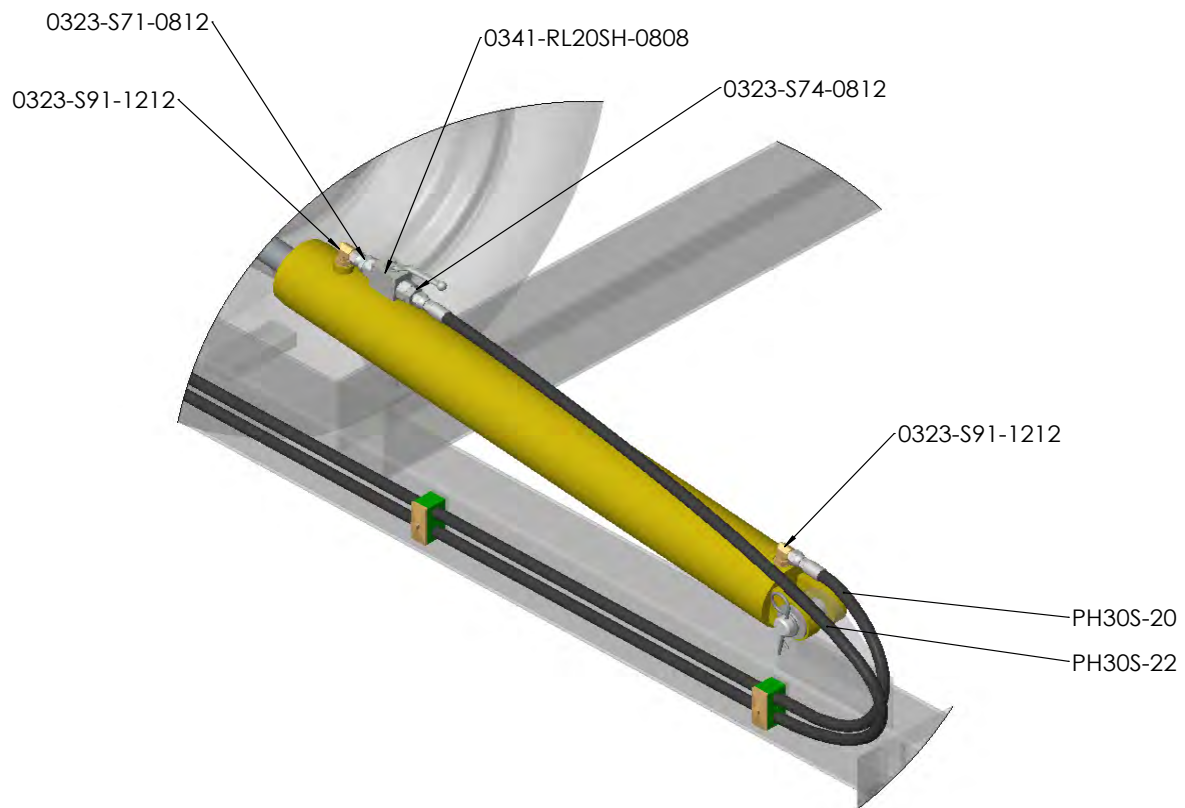

DETAIL D

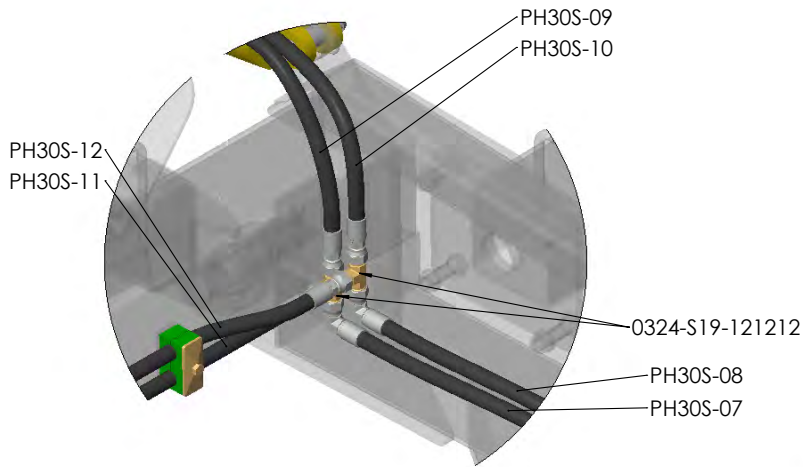

DETAIL E
Reverse View

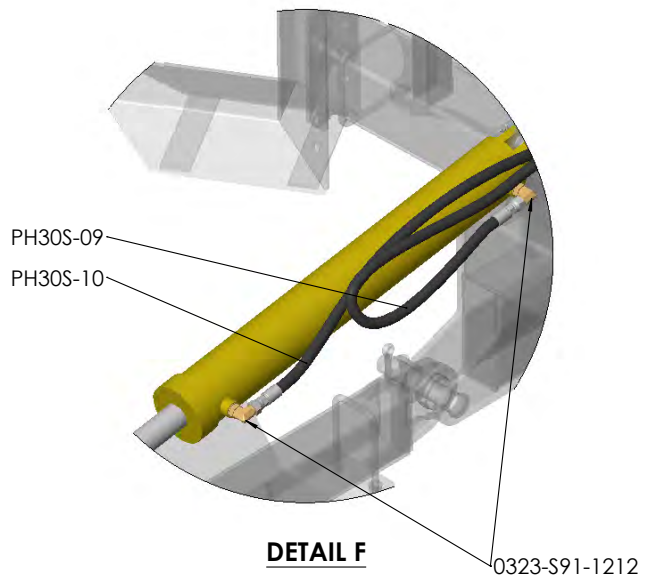

DETAIL F

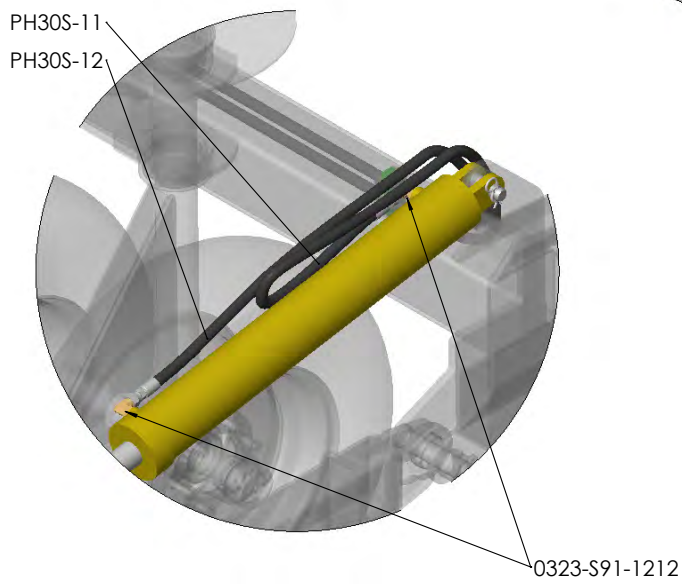

DETAIL G

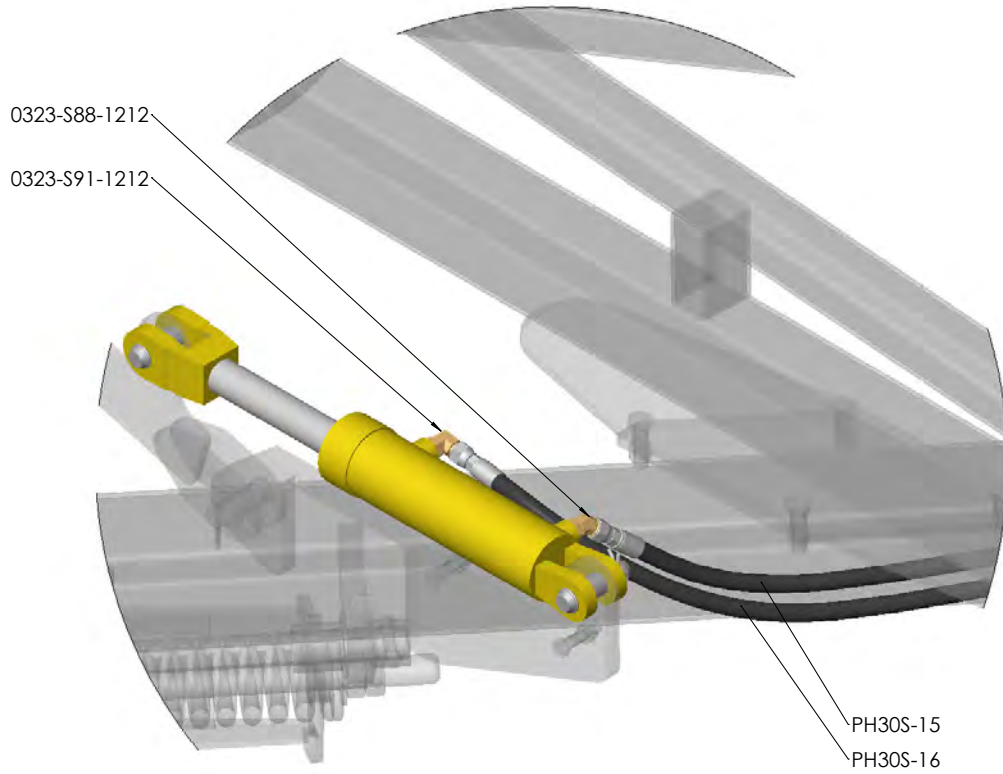

DETAIL H
Reverse View
Cover Removed

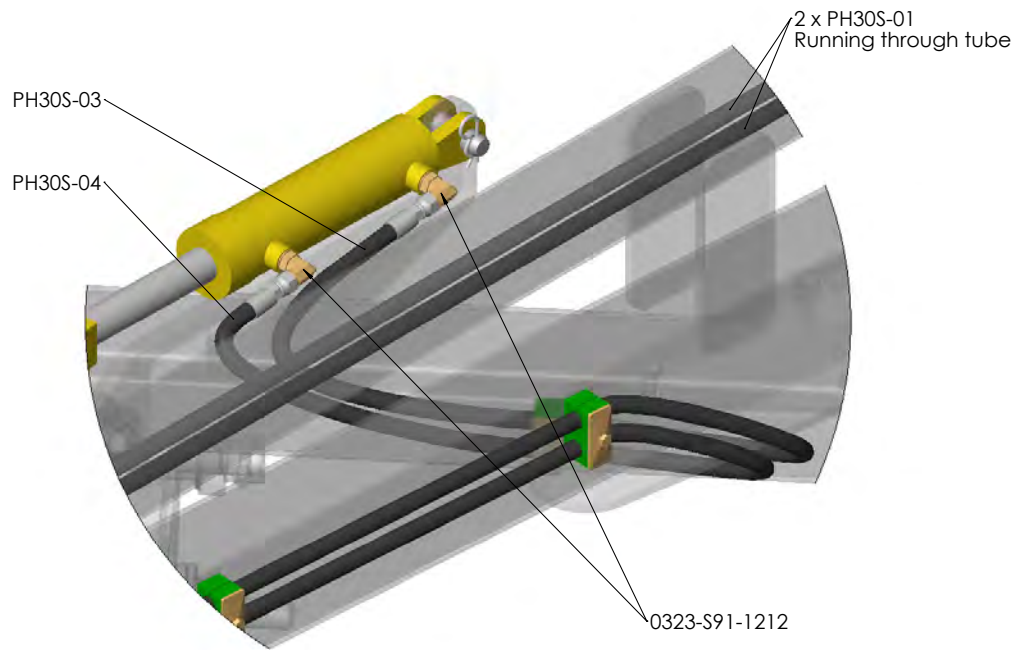

DETAIL I

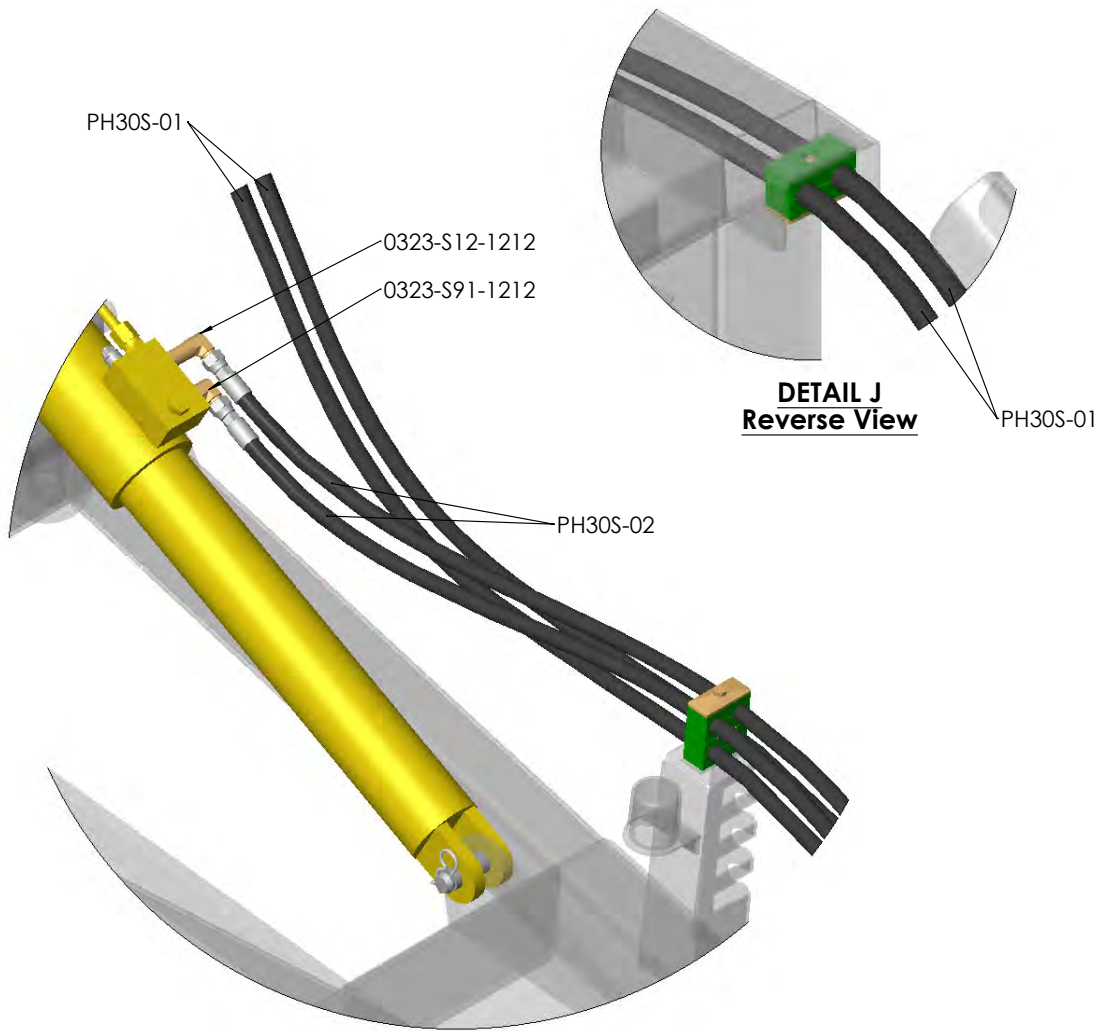

DETAIL K
Reverse View

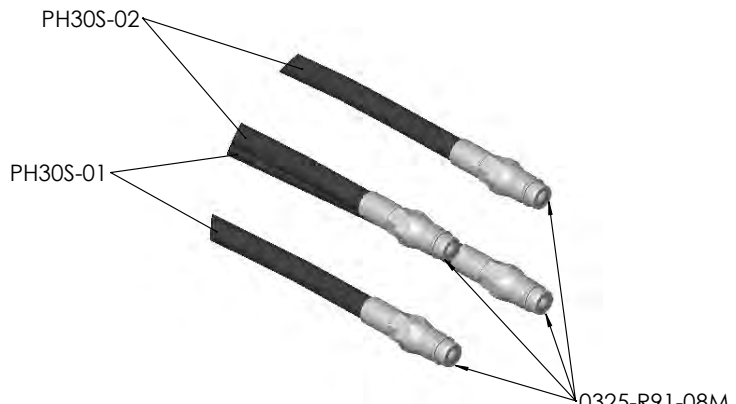

DETAIL L
Reverse View

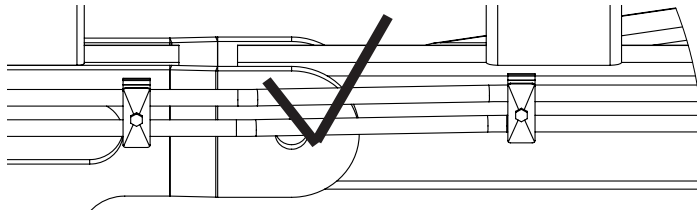

Correct layout of hoses



Avoid crossovers

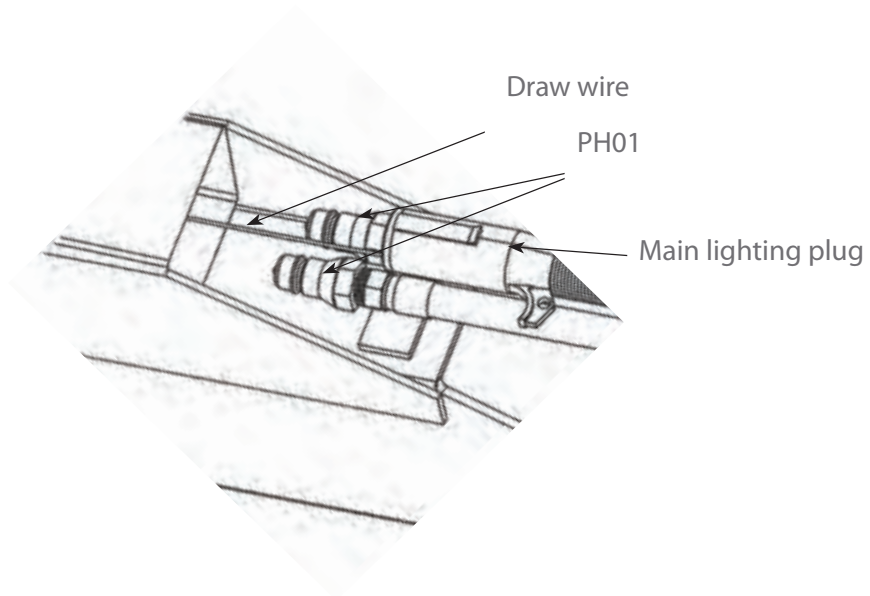

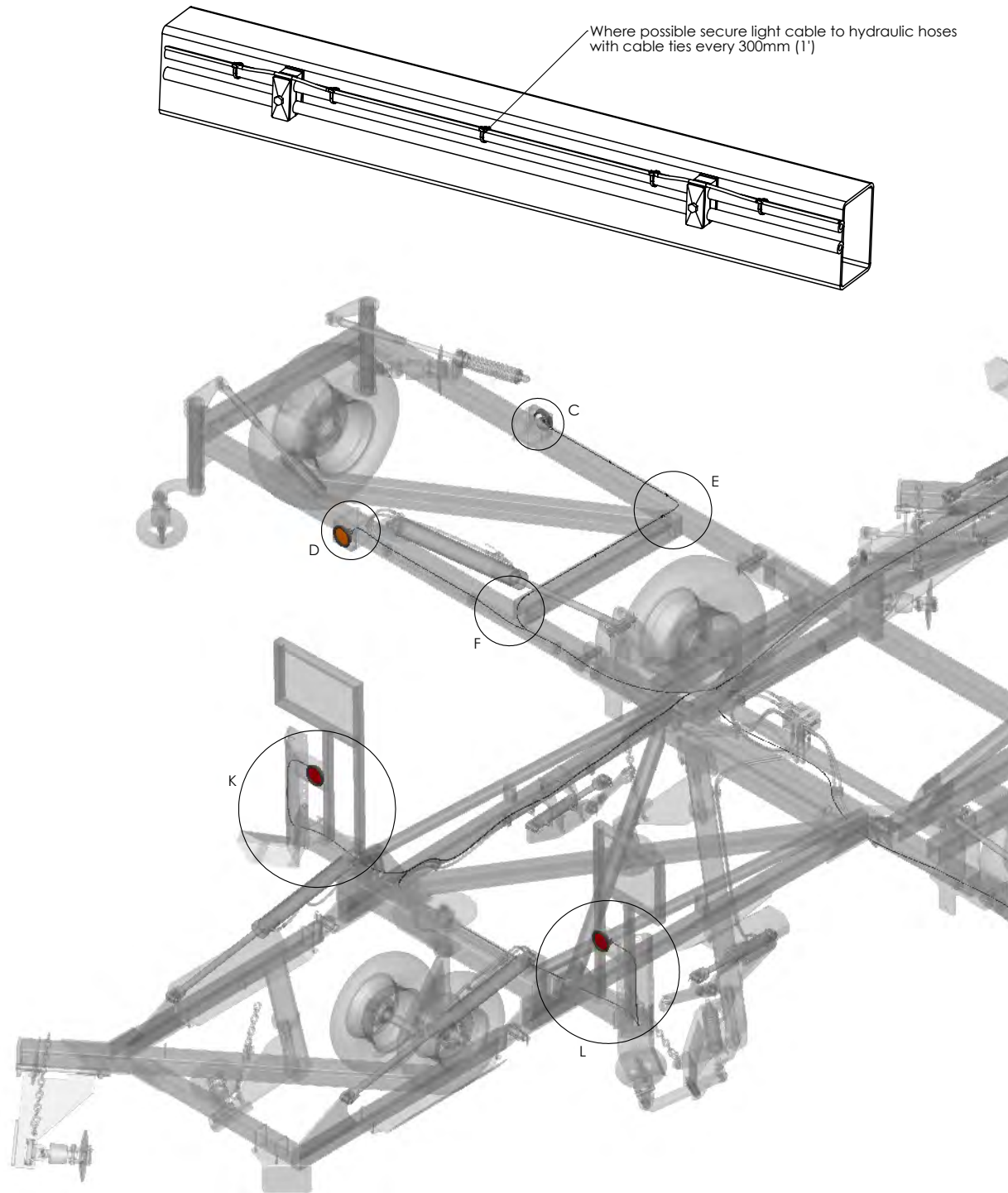

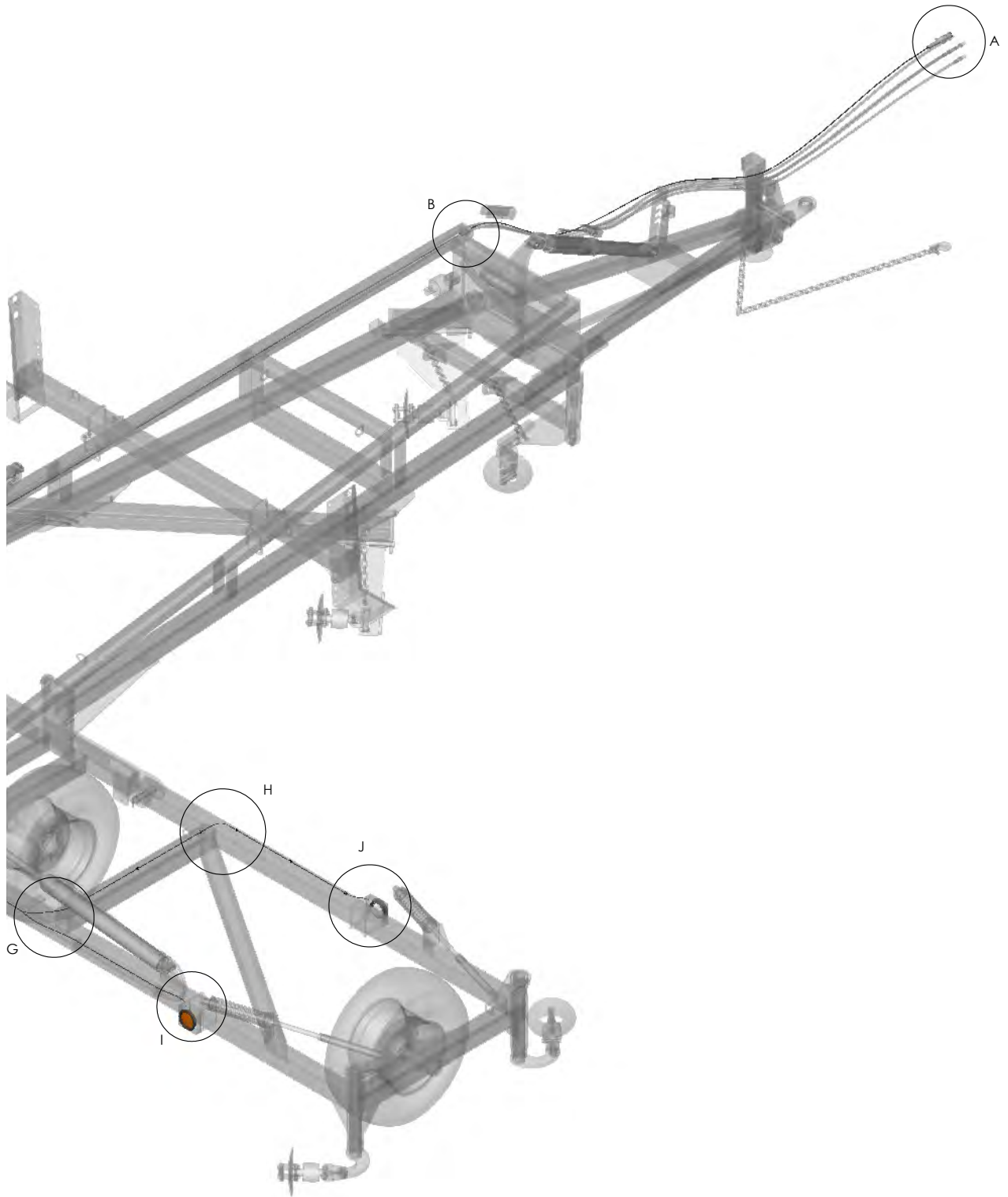



DETAIL A

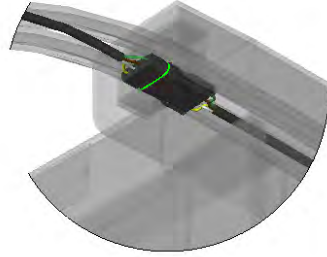

DETAIL B

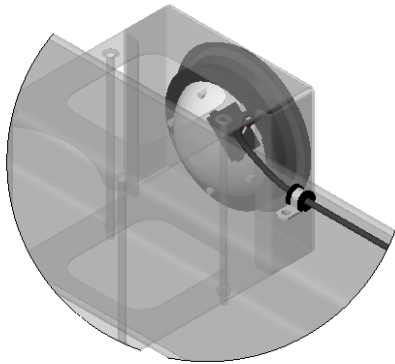

DETAIL C

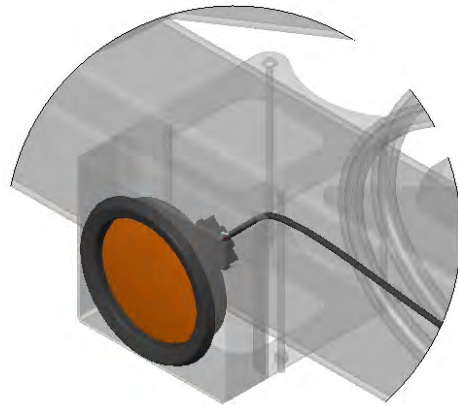

DETAIL D

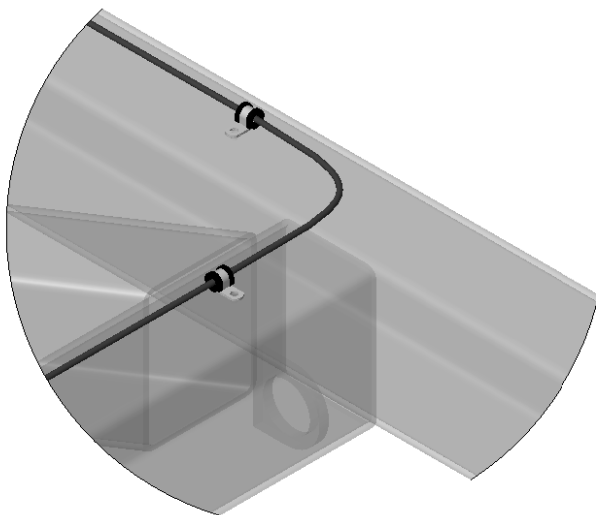

DETAIL E

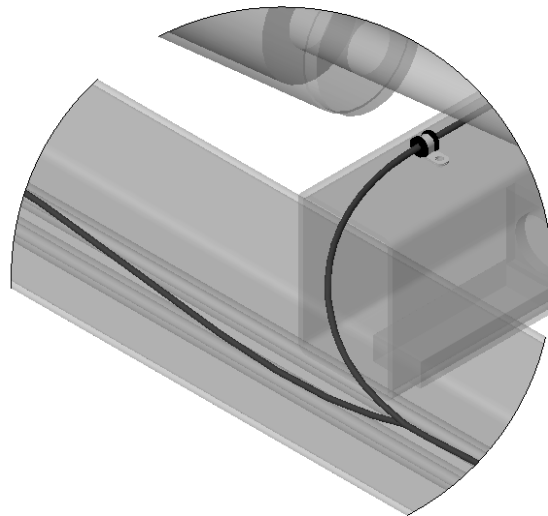

DETAIL F

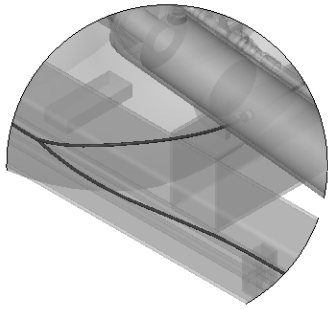

DETAIL G

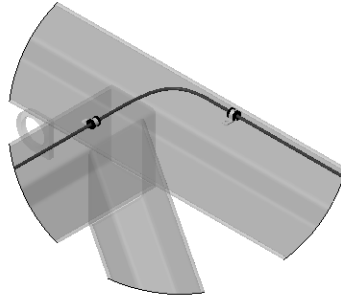

DETAIL H

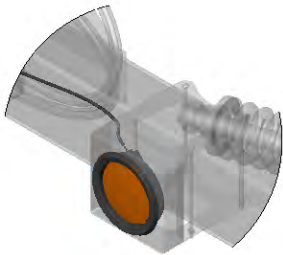

DETAIL I

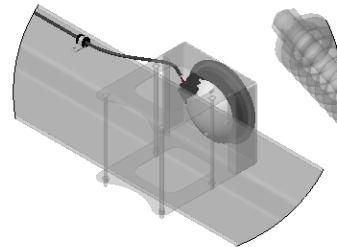

DETAIL J

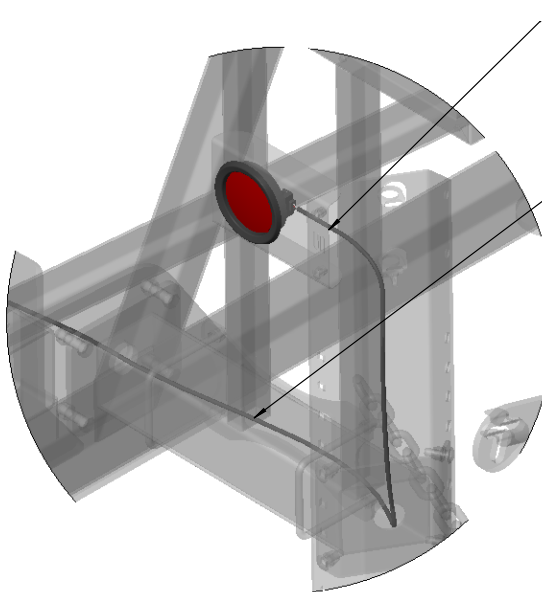

DETAIL L

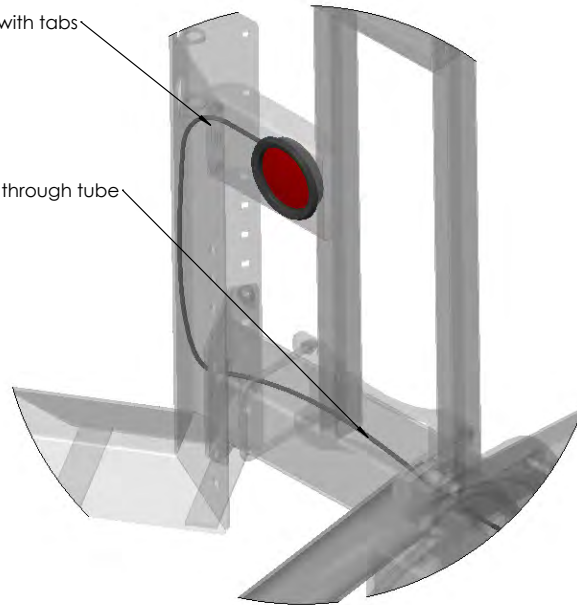

DETAIL K

Secure cable with tabs

Feed Cable through tube

Mounting swivels

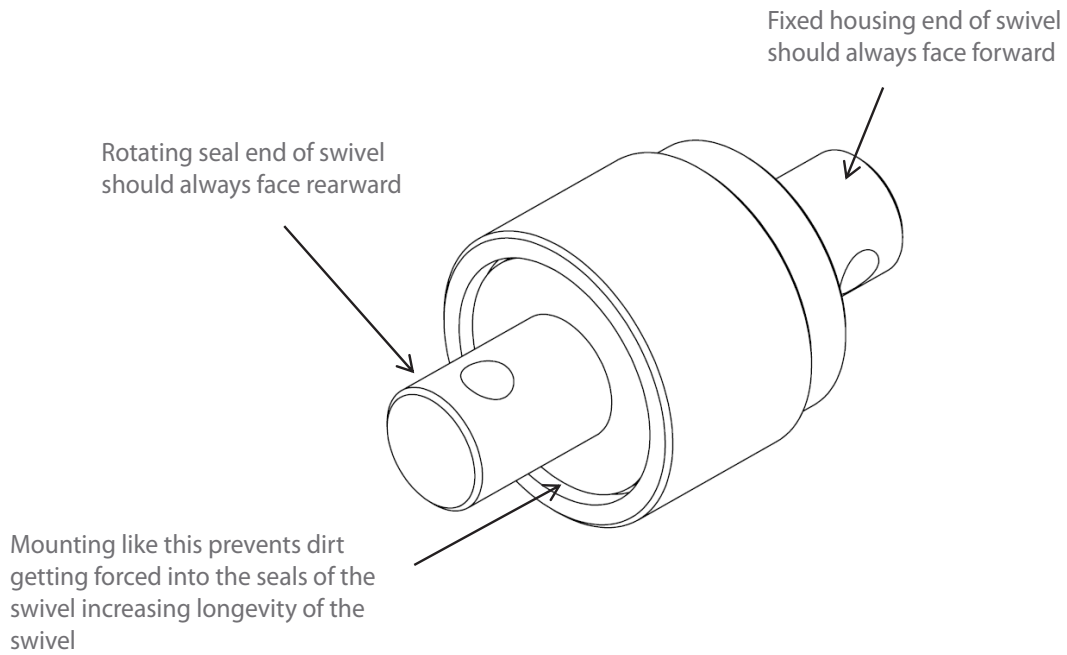

For example

Swivels attached to the leading ends of the chains should have the rotating seal end attached to the chain, as shown

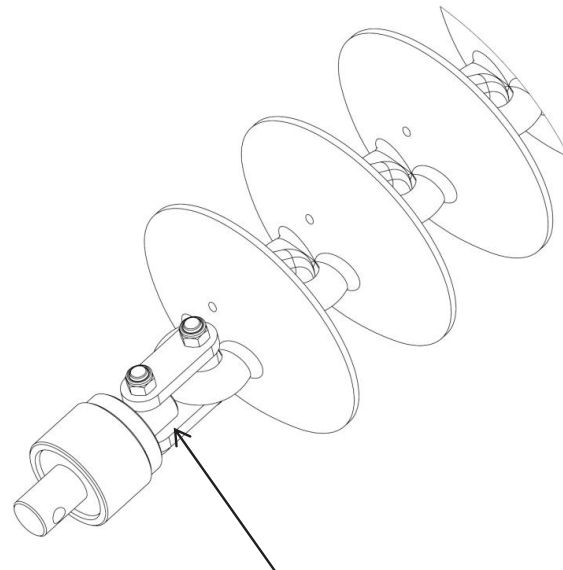
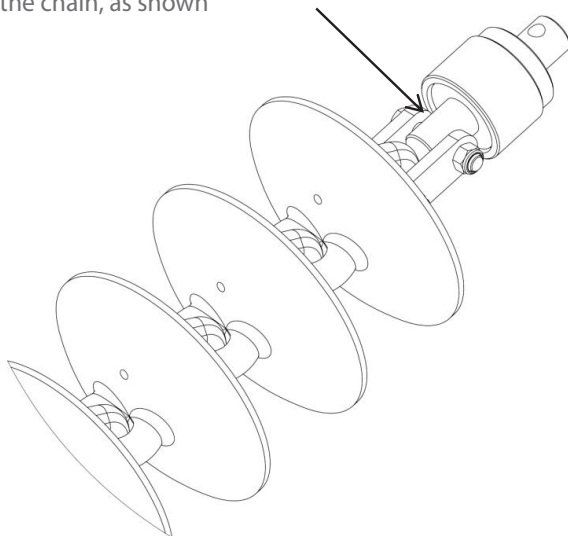

Swivels attached to the trailing ends of the chains should have the fixed housing end attached to the chain, as shown

Fitting cast link retaining pins

Please install cast link retaining Pins (3/8" x 3" Roll Pin, part number 0262-3-8X3) on all cast disc links. Failure to do this could lead to the discs becoming dislodged during transport causing severe damage or injury.

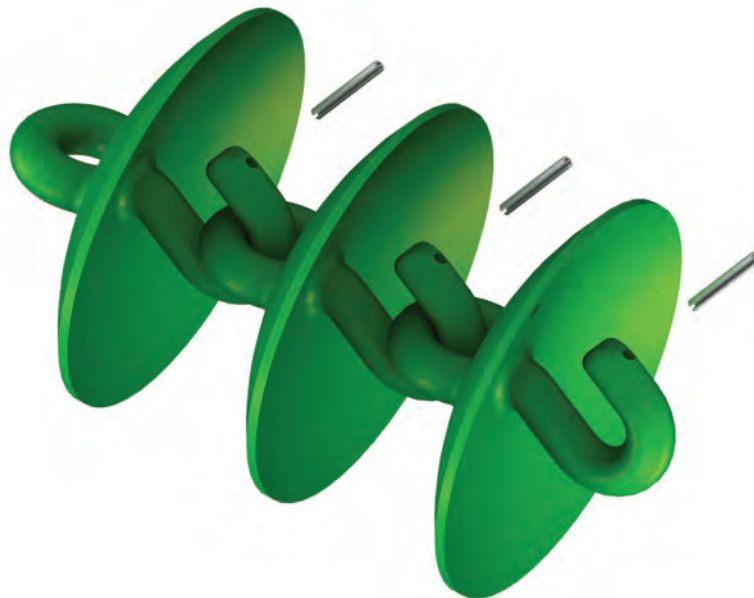
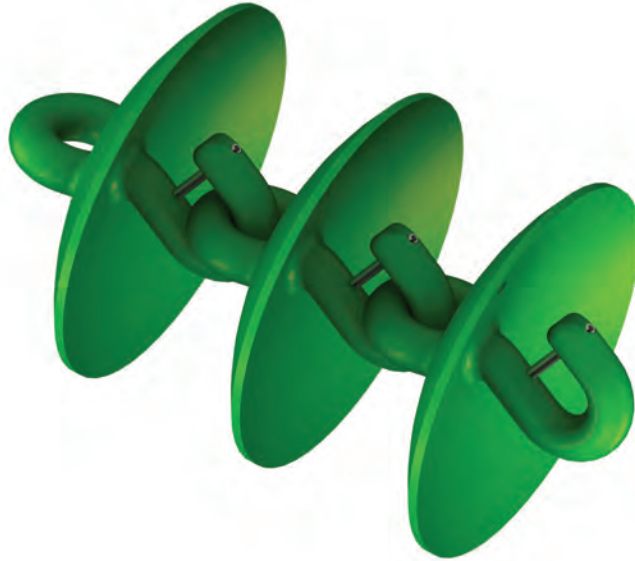

Operating speeds

Operating speeds for normal conditions	
Chain type	Speed
Prickle Chain	6-10 Mph / 10-16 kmph
Disc Mulch Chain	6-8 Mph / 10-12 kmph
Transport / towing on roads	15 Mph / 25 kmph

Tire pressure

Tire size	Ply	PSI	KPA
16.5L x 16.1	14	36	250
H40 x 14.5-19	26	60	410
11L - 15	10	44	300
15.5/80/24	16	58	400
16.5/85/24	16	55	380
550/60/22.5	16	40	280
400/60/22.5	16	50	350
12.5/80/18	14	85	590
15.0/70/18	14	71	490

Chain Harrow specifications

Model	30'/9m
Working width	28.5'/8.6m
Transport width	11.5'/3.5m
Transport height	13'/4.0m
Transport length	46'/14.0m

Bolt Torque Settings

Bolt Type	Wheel nut				U Bolt			Grade 8.8 Bolt					Grade 10.9 Bolt	
	M18	M20	1/2"	9/16"	M10	M12	M16	M10	M12	M16	M20	M24	M20	M24
Ft lb	255	265	90	100	22	36	55	32	48	140	190	270	300	350
Nm	345	360	125	140	30	50	75	44	65	190	260	370	406	475

[1] When fitting a wheel & tire to a hub, do the wheel nuts up in rotation to the correct tension. To achieve this choose a wheel nut & tighten, then go clockwise to the next wheel nut & tighten & so on until all wheel nuts are tight. Then repeat the procedure to check that all nuts are tight. Do not use impact tools to tighten wheel nuts. For a guide to the correct tension of the wheel nuts please use the appropriate tension for your size wheel nuts from the Bolt Torque Settings table.

Torque values are for dry threads and surfaces however it is permissible to apply a small amount of anti corrosive oil to the threads.

Disc Chain lengths

Model 30		Length	CL2	CL1	W36	R300	SD49	Prickle chain
			CL2 disc chain also requires CL1 disc chain					
30'	Front right	19'/5.8m	CL2 - 25 CL1 - 2	35	35	46	46	64
	Front left	19'/5.8m	CL2 - 25 CL1 - 2	35	35	46	46	64
	Rear right	24.4'/7.45m	CL2 - 25 CL1 - 15	48	47	63	63	87
	Rear left	19'/5.8m	CL2 - 25 CL1 - 2	36	35	46	46	64
	Modules front	7.4'/2.25m	CL2 - 9 CL1 - 2	14	14	19	19	26
	Modules rear	5.9'/1.8m	CL2 - 8 CL1 - 2	12	12	16	16	22

Section 4

Operation

Basic Operation

Unfolding:

1. Walk around and inspect the machine.
 - a. Check that chains are not hooked on framework
 - b. Check swivel bolts are in place and not broken
 - c. Check that height adjusting chains have not fallen out of their slotted plates during transport.
2. Lower front A frame to working height.
3. Unfold wings holding the hydraulic lever until the tail is in working position and the main center cylinder pins have centered in their slots.
4. Walk around and check that all chain links are straight and that working height of all swivels is correct for field conditions. Adjust if necessary.
5. Move off with all chains in working position. If necessary it is acceptable to raise front A pull to transport height. This will lift the front chains off the ground and reduce the load on the tractor. Lower the front A pull once moving satisfactorily.

Folding:

1. Lower the front A frame to working height. (This is important to ensure that all chains locate correctly in their transport rests).
2. Fold the wings. They should move as follows; modules will raise, tail will raise, main center cylinders will retract, one or both, until the wings stand vertically. The left outer wing then the right outer wing will fold down.
3. Raise front A frame to transport height.
4. Walk around and check that chains have located correctly in transport rests.
(30' only, install wing transport lock pins).

Setting for correct chain tension

Wings

Use the spanner supplied. Loosen the lock nut adjacent to the tensioner assembly body. Turn the tension bolt clockwise to compress the coil spring. Correct tension is achieved when spring retains its set length when operator rolls the chain fore and aft on the ground. Retighten the lock nut.
See table below

Spring Compression Length

Model	inches	mm
30	12.9	330

When less than 4" (100mm) of thread remains visible on the adjustor bolt then a link must be removed from the chain



Modules

Loosen the lock nut on the draw bolt.

Tighten the adjusting nut clockwise until the outer face of the spring retaining washer is flush with the body of the module tensioning unit.

Retighten the lock nut.

If more than 8" (200mm) of thread is exposed then a link should be removed to maintain correct adjustment.



Importance of chain tension

Operational

It is imperative that the correct adjustment be maintained. Only through correct adjustment can a smooth and level finish be achieved in field working.

Loose chains lead to :

- Uneven performance across the width of the machine
- Uneven weed control
- Unsatisfactory incorporation
- Ineffective levelling
- Accelerated or premature chain wear
- Chains failing to engage with transport locators when folded
- Machine damage when folding or unfolding
- Uneven field surface with ridges and furrows being created. The leading 1/3rd of a loose chain is much more aggressive than the trailing 1/3rd and the center. This will mean that middle of the machine's front pair of chains will aggressively move soil outwards. The machine's rear pair of chains, if loose, have their aggressive 1/3rd near the wing extremity. It follows then that as the front discs push soil outwards, the least aggressive portion of the rear chain follows them and does not balance the soil movement. This is exacerbated at the wings, effectively creating a broad ridge about halfway out each wing. It won't be evident in one pass, but is possible if care is not taken over time.

A correctly adjusted machine will not cause this phenomenon.

Settings for correct working height

To adjust the swivel height at the wings, relocate one of the polyurethane spacers either above or below the fixed mounting tube.

Adjustment

1	Loosen chain tension completely
2	Undo self tapping screw from corresponding spacer then prise open the spacer and spring it off of the drop leg tube
3	Replace it in the selected position after raising or lowering the drop leg
4	Reinstall the self tapping screw and re-tension the chain

It is possible to install all spacers either above or below the mounting tube giving a maximum of 4" (100mm) of adjustment.



Front Cylinder Depth Stop

ITEM NO.	PART NUMBER	Revision	DESCRIPTION	QTY.
1	0211-12110SHSCREW	A	Shoulder Screw M12 x 16 x 110	2
2	0231-SPRINGCUP	A	Compression Cup Washer	7
3	0800-278	A	Cylinder Depth Stop Plate	10

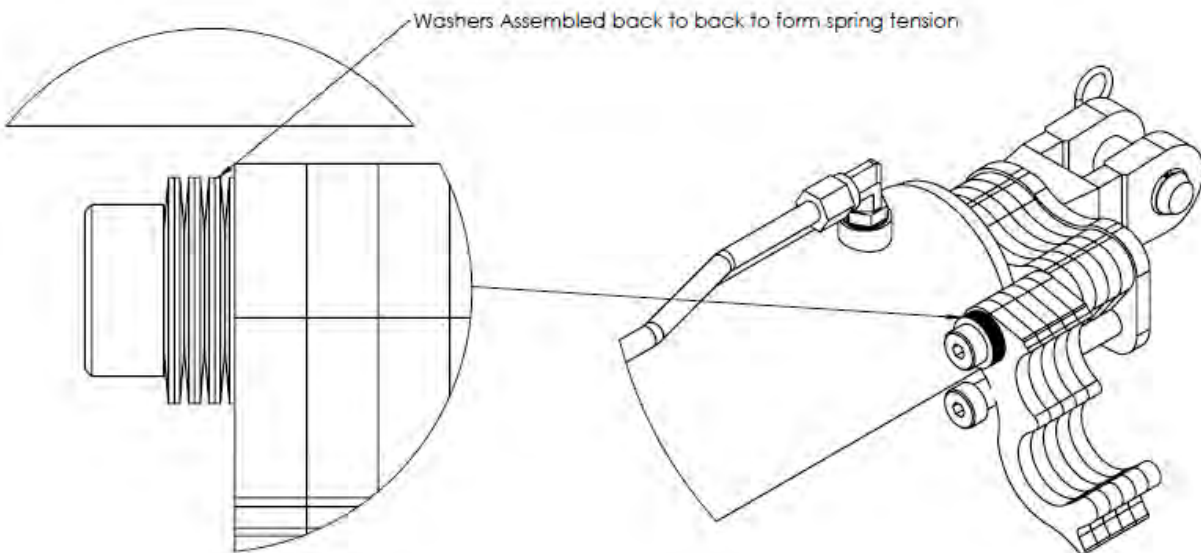
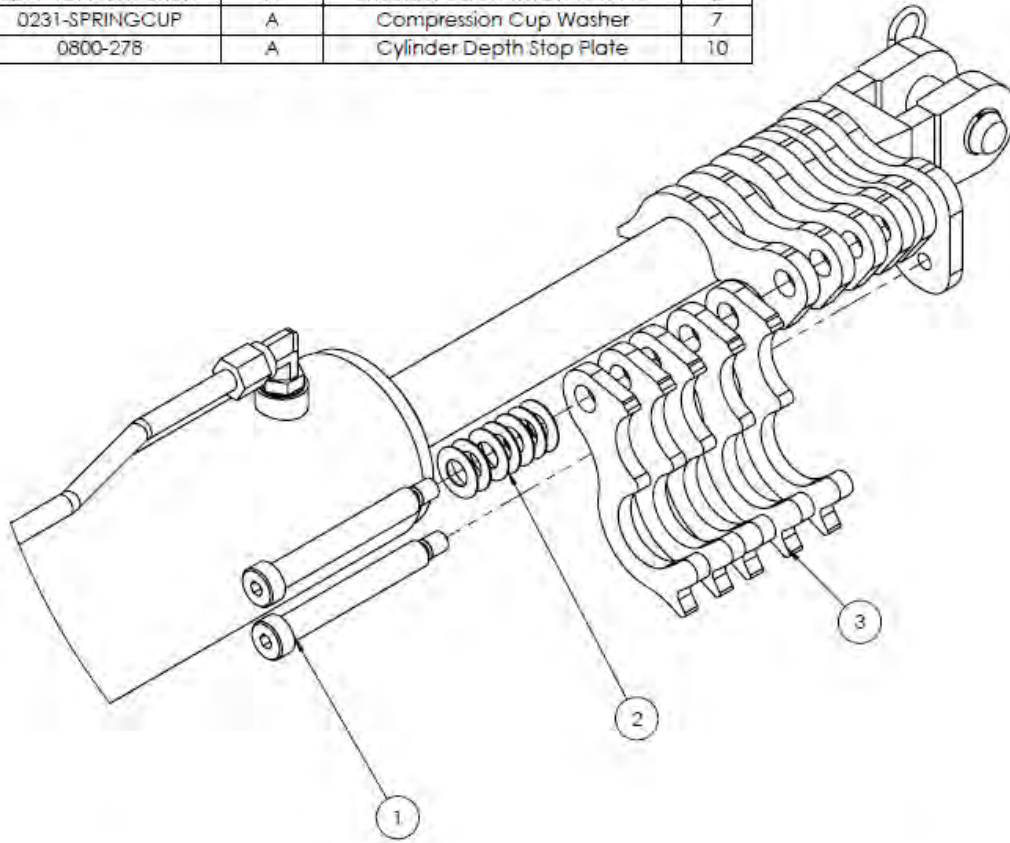

Hydraulic Valve Block

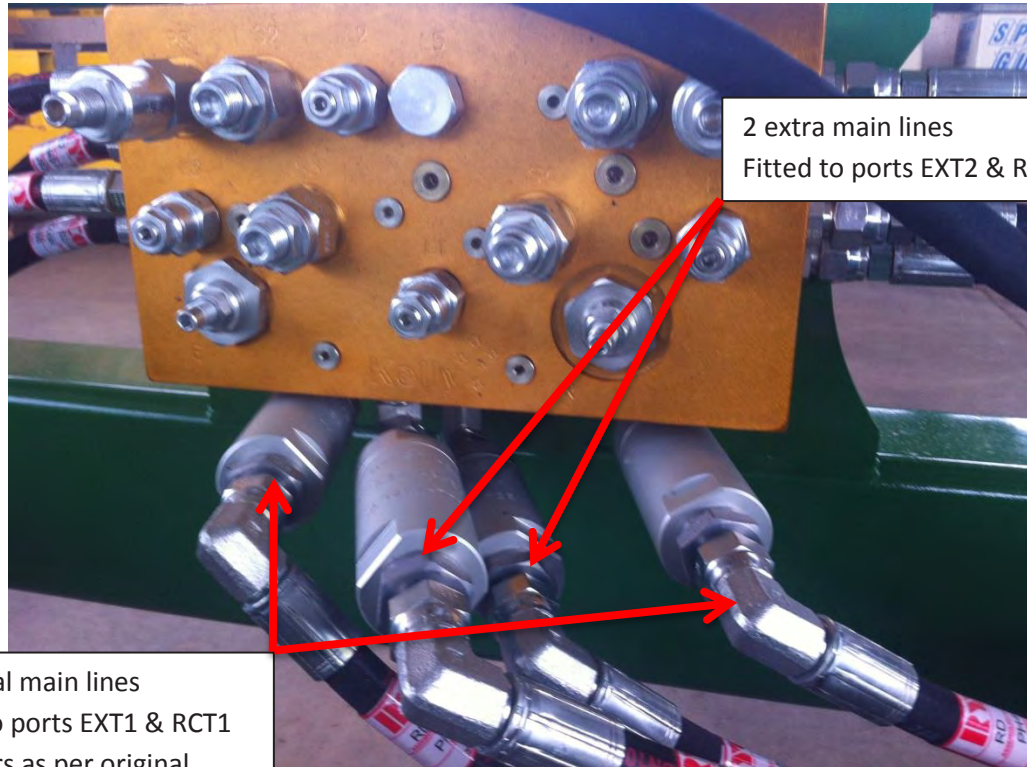

2 extra main lines
Fitted to ports EXT2 & RCT2

2 original main lines
Fitted to ports EXT1 & RCT1
Via filters as per original
OUT end of filter to valve
block



Extra stack clamp added to
mount extra main lines to
existing main lines



New hose mount post with
extra storage points

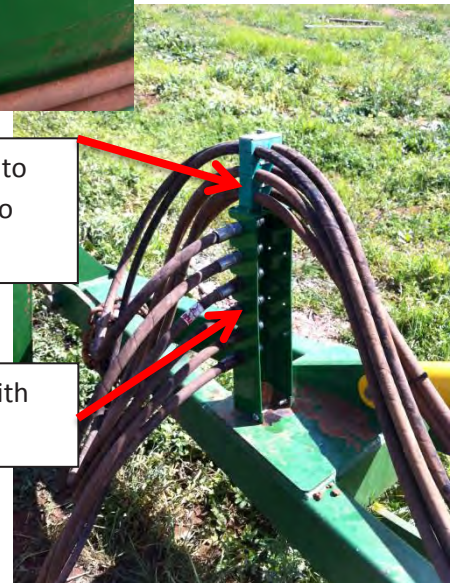

Rear Light Brackets

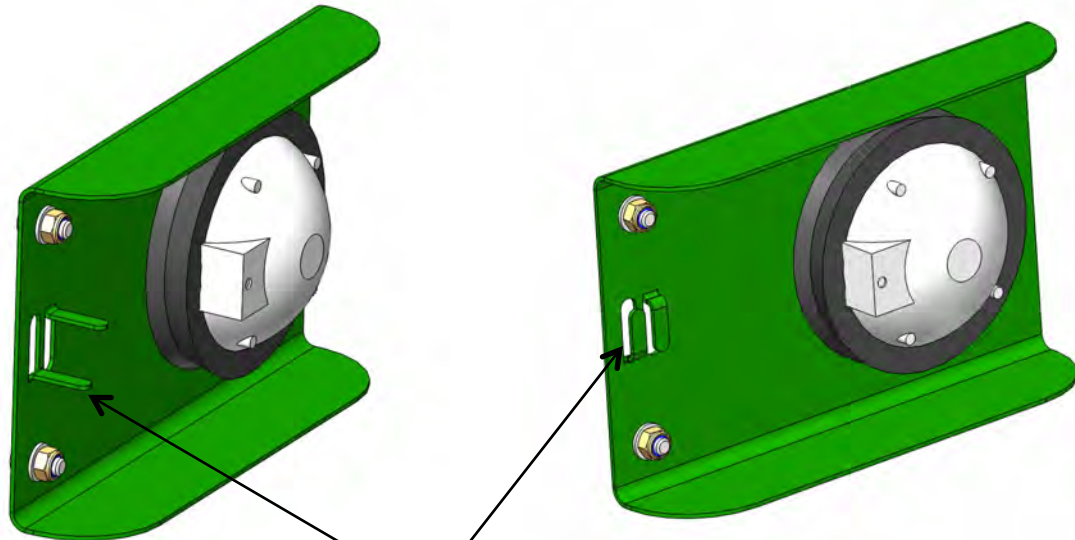

Please ensure to bend tabs up and feed wire through, so the light cable is secure

Mount to chain carrier with 2x M8x20 cup head bolts, Flat washer and Nylon nut

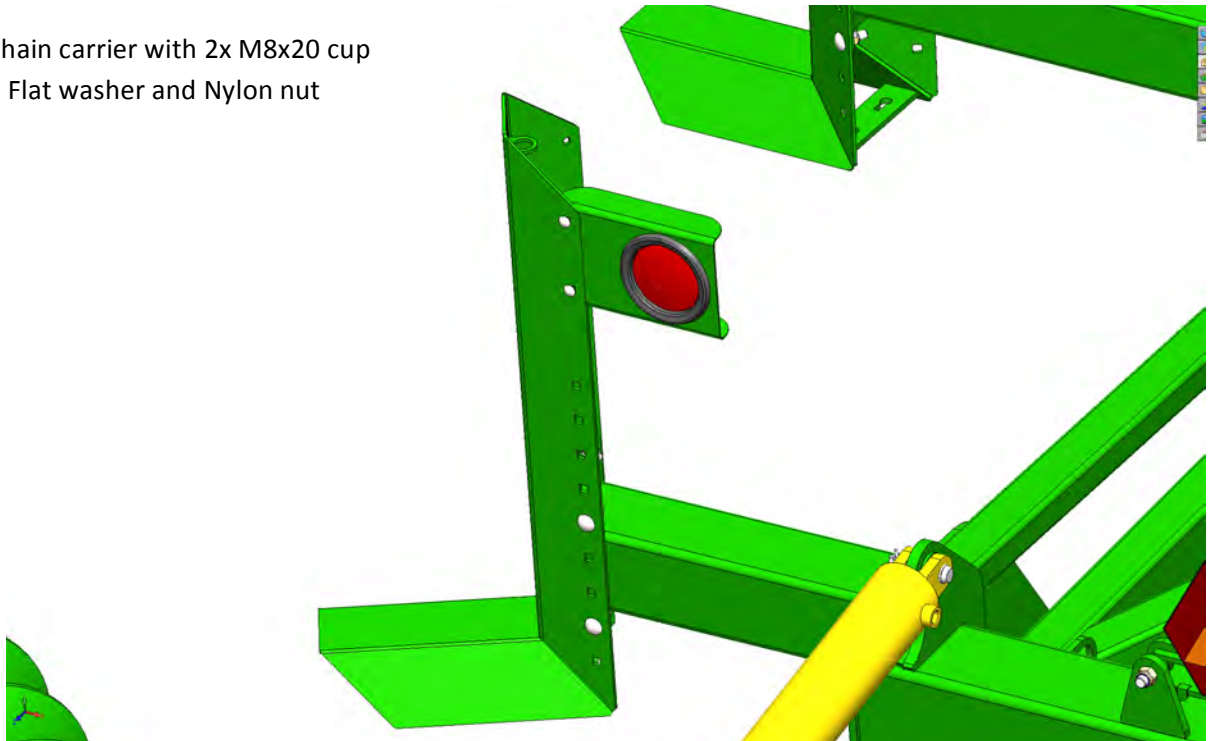

Brake Disc Collar (Revision B)

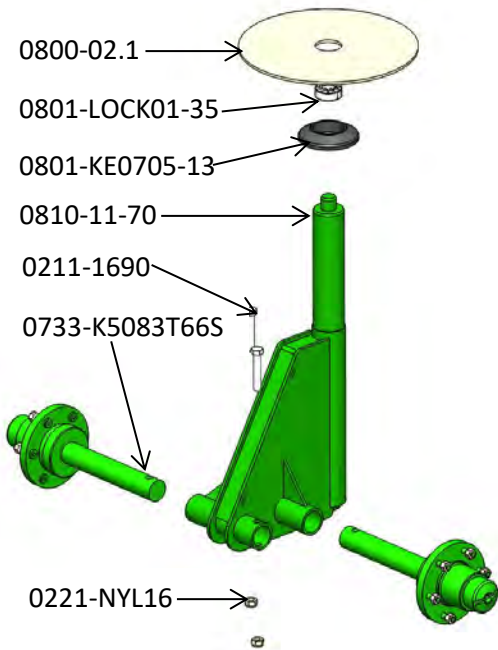

Slide shaft of jockey wheel up through both bearings.

Place black dust cover onto top bearing.

Slide disc brake into the calliper and over the top of jockey wheel.

Ensure when unscrewing bolts to fit collar over that some thread is still engaged otherwise you will not be able to screw bolt in.

Slide collar over shaft and inside the brake disc hole.

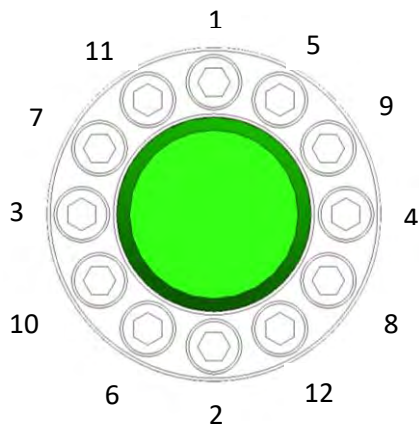
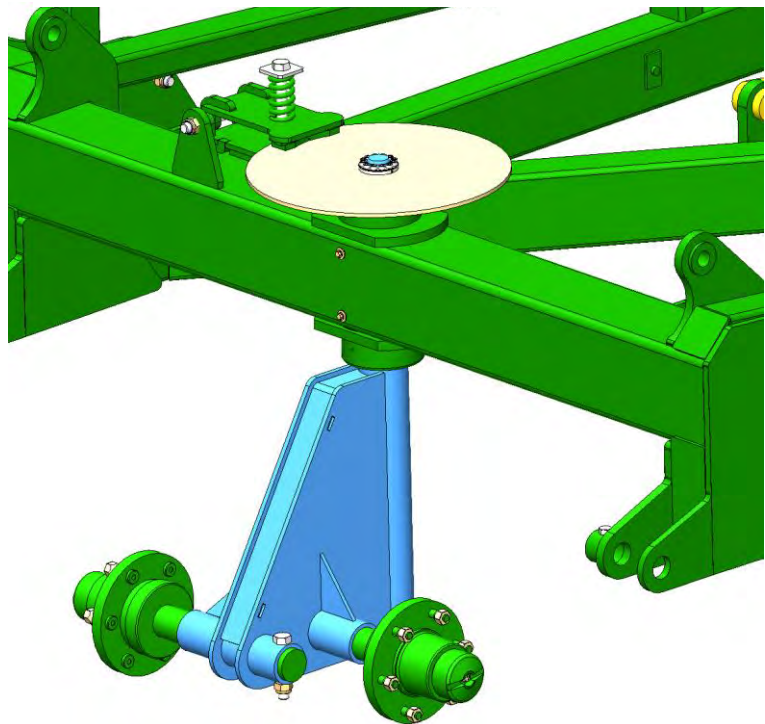

Tighten in a cross pattern, Bring all bolts up equally to 17Nm (12.54 Ft/Lbs) (caution if a single bolt is done up to tension there is a risk of the bolt breaking)

To undo, remove all bolts and gently tap collar with a hammer and collar should become loose.

Correct Hose Attachment

Please note that when attaching hoses to sequence valve block to check that hoses are connected to the correct port.

Ports with CE, LE or RE are extend ports (the E denotes Extend) and hoses connected to these must go to the rear end of the cylinder.

Ports with CR, LR or RR are retract ports (the R denotes Retract) and hoses connected to these must go to the rod end of the cylinder.

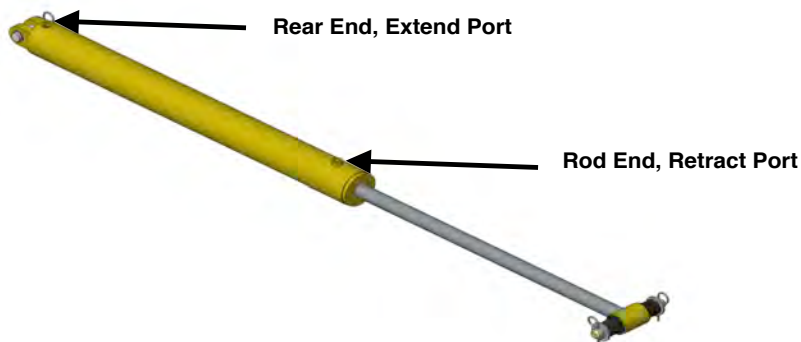

CL2 Chain Configuration - All machines

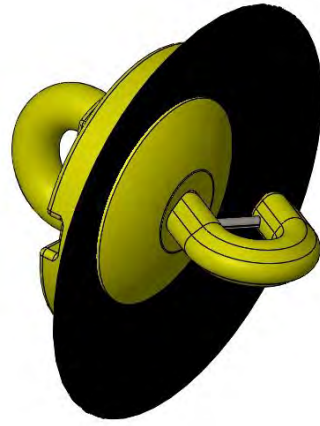

0803-CL2-Link Assembly

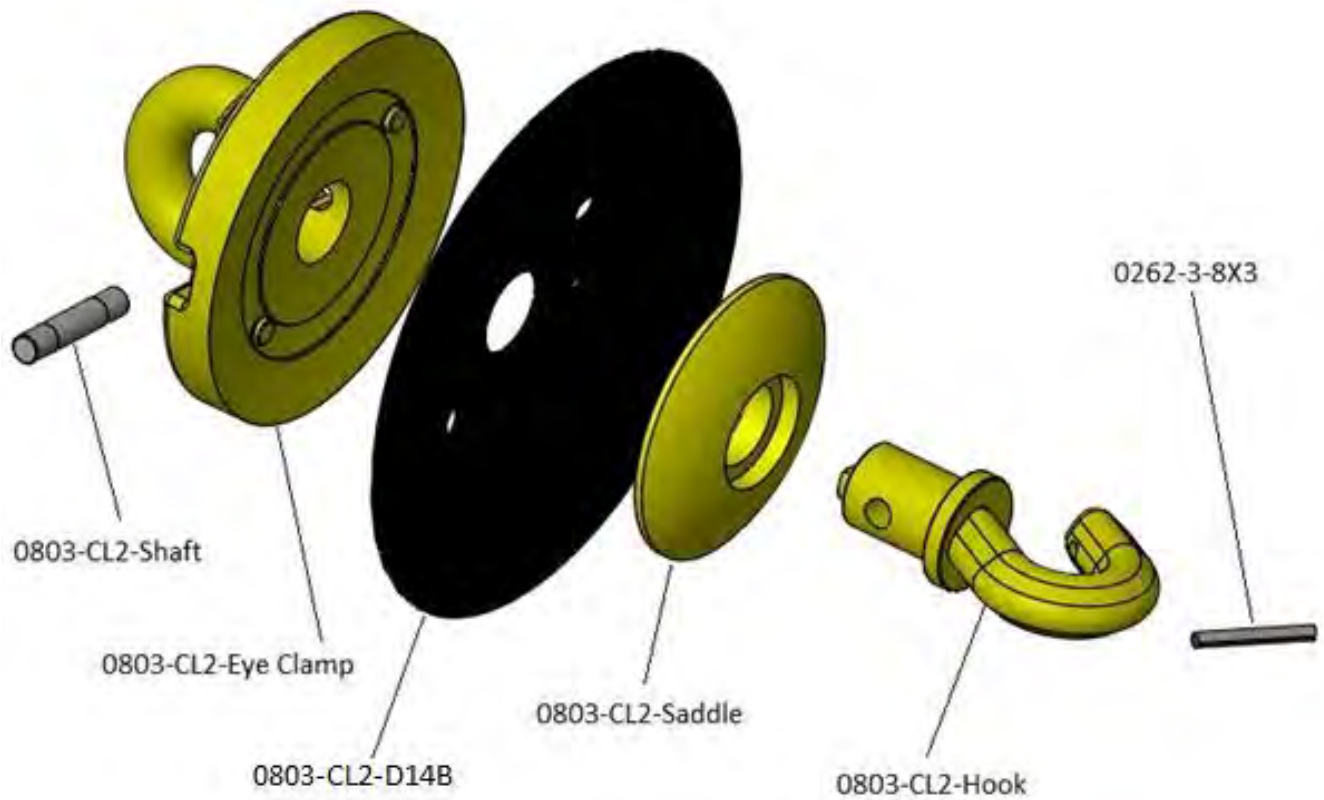

CL2 Chain Configuration - 30ft

30' Machine

0803-CL230F

Comprises:

- 58-off CL2 disc
- 7-off CL1 disc

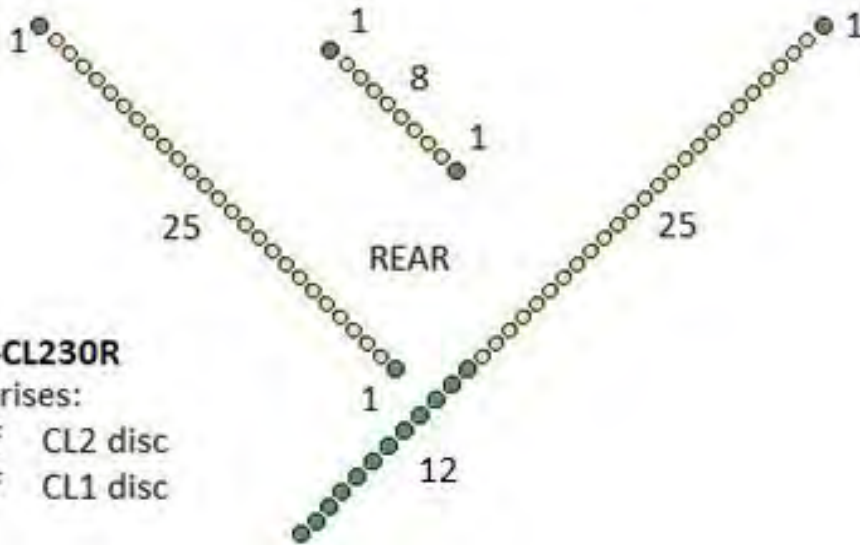
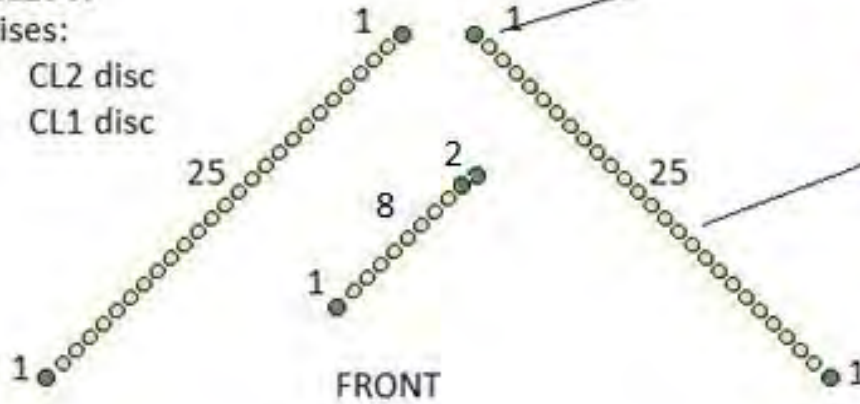

0803-CL230R

Comprises:

- 58-off CL2 disc
- 17-off CL1 disc

Chain Tensioners on Rear Tail

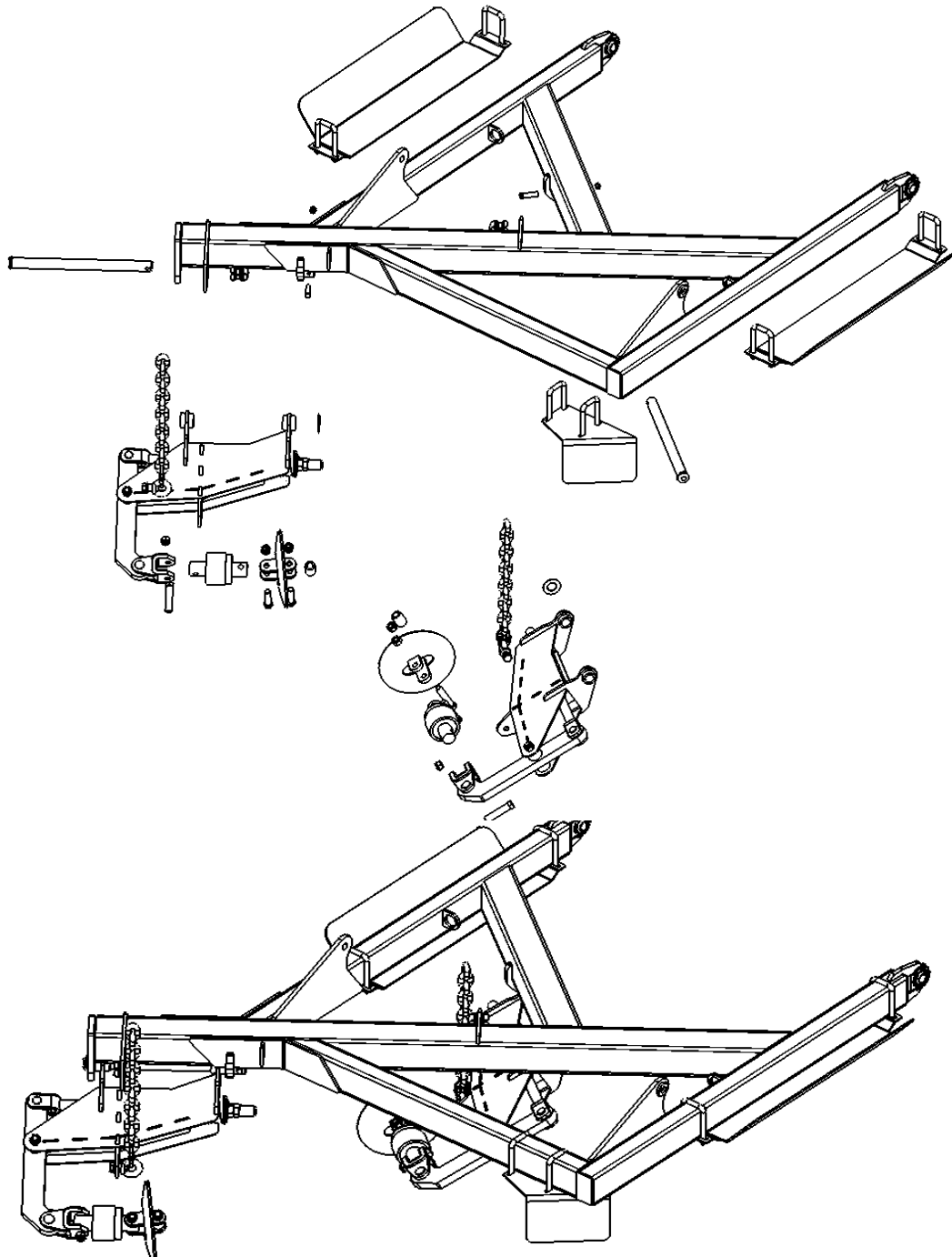

Chain Tensioners on Rear Tail

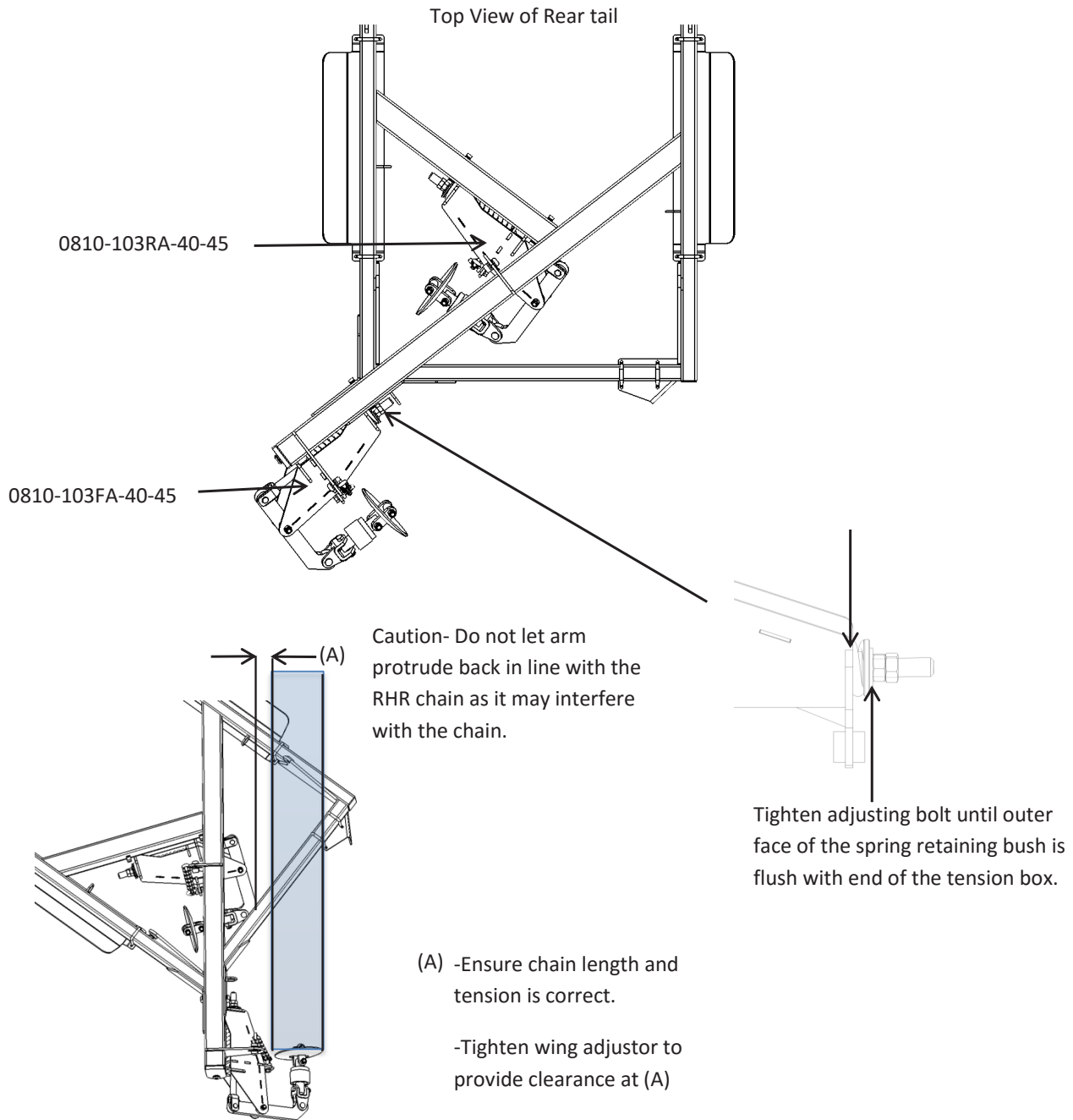

Chain Tensioners on Rear Tail

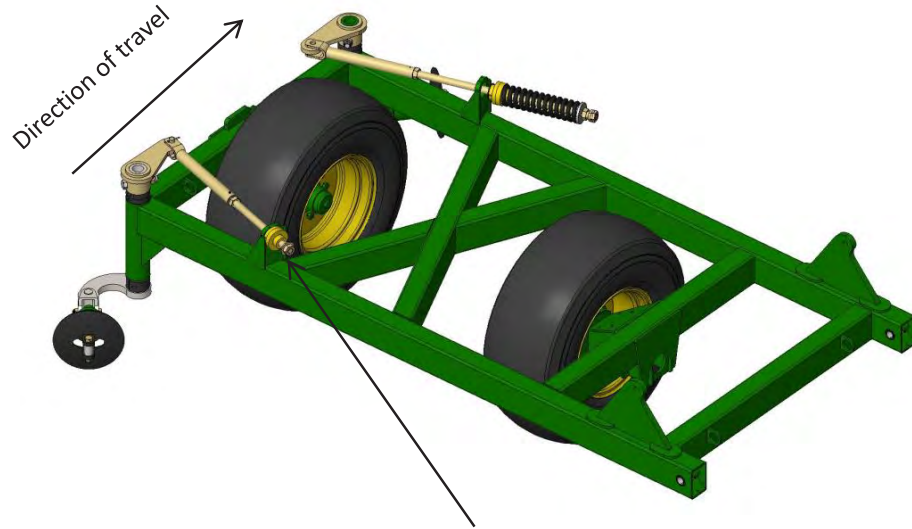

When fitting the Chain tension boxes on the rear tail the outer wing drop leg becomes fixed. The existing spring is used on the tension box on the rear tail.

Please note-Exchange the spring and 0801-PCHTA for Part no 0801-PCHTA-S, on rear of both outer wings only.

Exchange spring and 0801-PCHTA for shorter 0801-PCHTS-S

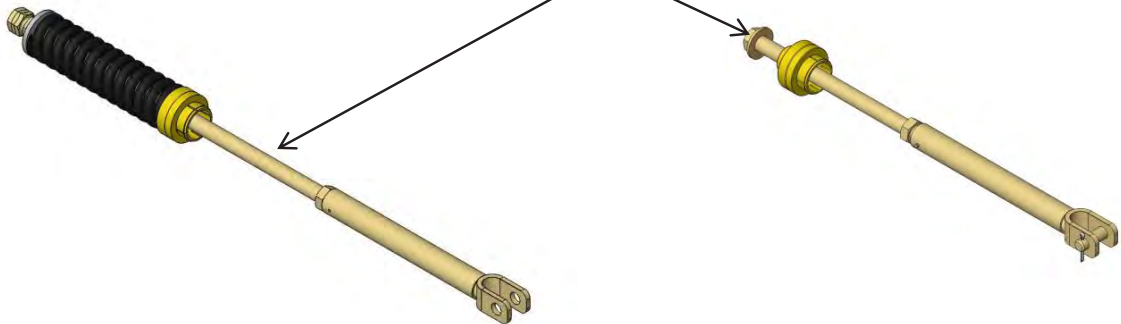

CL2 Disc Change Procedure

This document describes a procedure for the safe changeover of CL2 discs.

NOTE: Each disc weighs 22kg (48lb). Appropriate care must be taken during manual handling

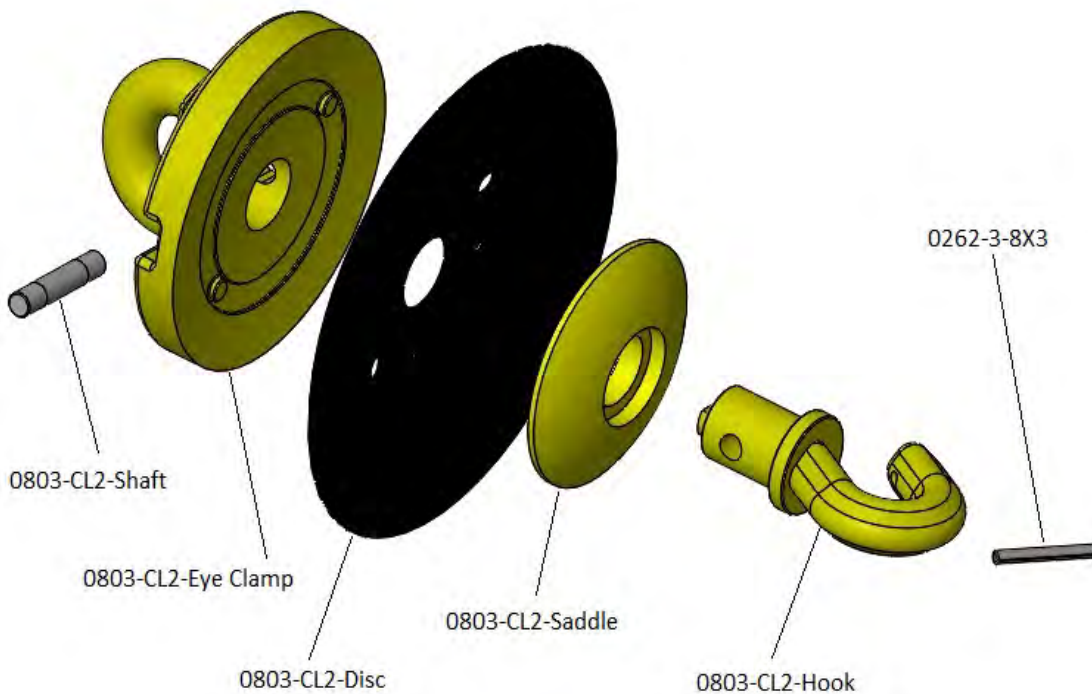

Figure 1: Exploded view of CL2 disc assembly

Changeover procedure as follows:

1. Locate press jig in press (see Figure 2 for orientation).
2. Load disc into press with Hook facing upwards - ensure that Eye Clamp and Hook are secured within the jig with pins supplied
3. Close press, applying force to Saddle (see Figure 3). DO NOT exceed pressure of 9 Tonne (19,800lb)
4. With the clamping force applied, push or tap the shaft with a hammer & drift, and remove from the CL2 Disc assembly
5. Open the press and remove the Disc from the assembly
6. Ensure that all surfaces of the castings are free from debris

CL2 Disc Change Procedure

7. Place replacement disc on to Eye Clamp, ensuring that location holes align with casting lugs
8. Close press and re-apply clamping force. Visually confirm that Hook location hole is properly aligned with Eye Clamp location hole
9. Locate pin within hole and tap gently through both castings
10. Remove clamping force, and remove CL2 assembly from jig
11. CL2 disc is now ready for use. Repeat procedure as necessary

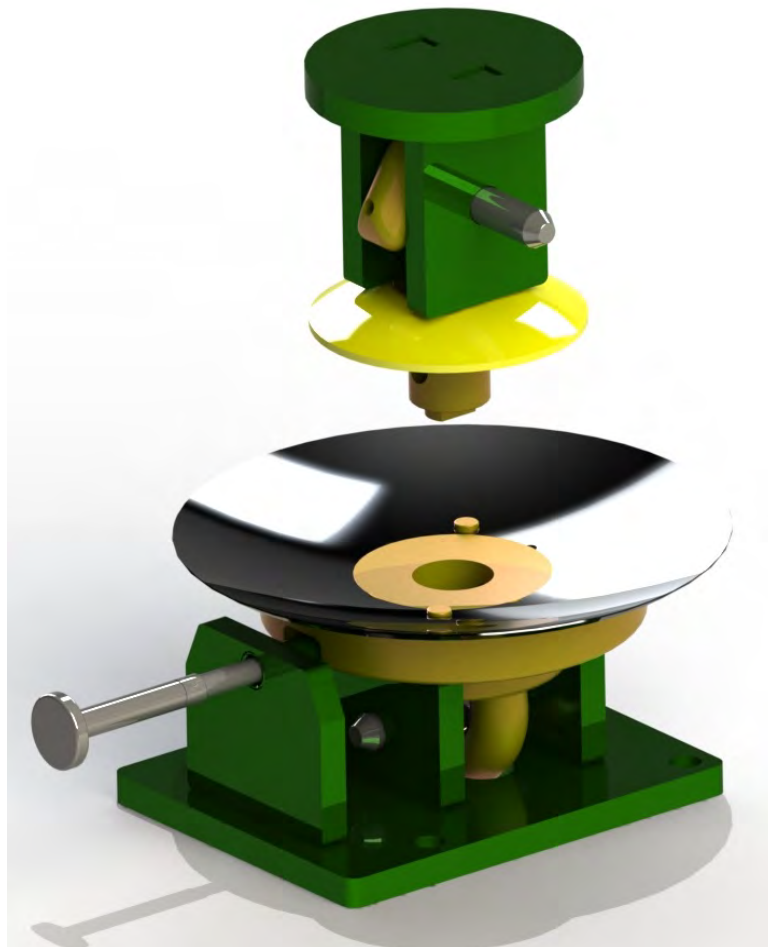

Figure 2: CL2 disc with press jig in Open position

Brake Disc Collar (Revision B)



Figure 3: CL2 disc with press jig in Closed position

