



Better Tillage. Better Tomorrow.

# Assembly Manual

## KELLY TILLAGE SYSTEM 3009AEUSA

KEASM-C-AEUSA-01072023

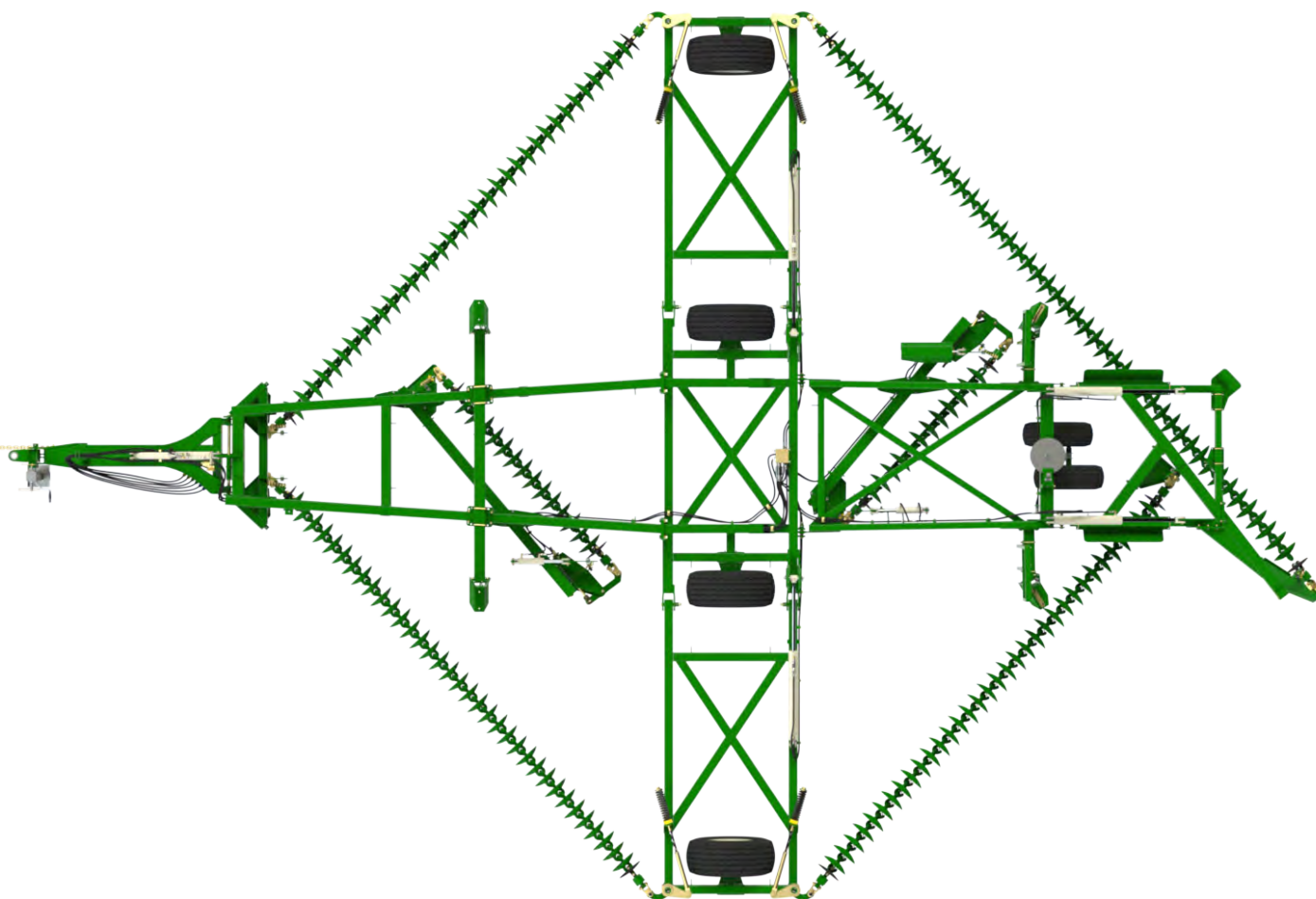

SERIAL NUMBER:



Phone +61 8 8667 2253  
Email [sales@kellytillage.com](mailto:sales@kellytillage.com)  
[kellytillage.com](http://kellytillage.com)

**Booleroo (Head Office)**  
684 Kelly Road,  
Booleroo Centre SA 5482

**Adelaide Office**  
28 Greenhill Road,  
Wayville SA 5034





# Thank you for choosing a KELLY product.

We trust that you find the following manual clear and easy to follow. If you should require additional customer support or assistance, please do not hesitate to contact us.

Spare parts can be purchased, as required, through your local dealer or by contacting KELLY directly.

The KELLY team values your feedback. Should you have any difficulties that you wish to raise, suggestions for improvement or modifications that you feel would enhance our products we look forward to hearing from you.

## Contact Us

### Australia

#### Booleroo (Head Office)

684 Kelly Road,  
Booleroo Centre SA 5482

+61 8 8667 2253

Monday - Friday  
8am - 4pm ACDT

#### Adelaide Office

28 Greenhill Road,  
Wayville SA 5034

+61 8 8667 2253

Monday - Friday  
8am - 4pm ACDT

## Global Locations

#### Eastern Canada

Leading Edge Equipment  
[www.leadingedgeequipment.ca](http://www.leadingedgeequipment.ca)

1-519-421-3223

Monday - Friday  
8am - 4pm EST

#### Western Canada

Adair Sales & Marketing Co Inc  
[www.adairreps.com](http://www.adairreps.com)

1-306-773-0996

Monday - Friday  
8am - 5pm CST

#### United States

Hood & Company

+1 417-865-2100

Monday - Friday  
8am - 4pm CST

#### Europe

[kellytillage.com](http://kellytillage.com)

+61 8 8667 2253

Monday - Friday  
8am - 4pm ACDT

#### Argentina

Giorgi Sa Maquinarias Agrícolas  
[www.giorgi.com.ar](http://www.giorgi.com.ar)

+54 3464 493512

Monday - Friday  
8am - 5pm ART

#### South Africa

Desmond Whitfield CC

+27 82 567 8245

Monday - Friday  
8am - 4pm SAST

# Contents

|                             |     |
|-----------------------------|-----|
| Section 1 - Unpacking       | 5   |
| Section 2 - Assembly        | 8   |
| Section 3 - Decal Placement | 101 |
| Section 4 - Light Kit       | 116 |
| Section 5 - Chain Assembly  | 124 |
| Section 6 - Specifications  | 135 |
| Section 7 - Operation       | 138 |
| Notes                       | 141 |

## Legend



This symbol indicates which bag the relevant fasteners are in.



This symbol indicates which bag the relevant hydraulics are in.

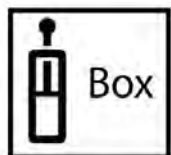

This symbol indicates the hydraulics are in a box.



This symbol indicates which way the machine is travelling.

## Bolt Torque Settings

| Bolt Type | Wheel nut |     |     |      |       | U Bolt 4.6 |     |     |     | Grade 8.8 Bolt |    |     |     |     |     | Grade 10.9 Bolt |     | Grade 8 Bolt |        |
|-----------|-----------|-----|-----|------|-------|------------|-----|-----|-----|----------------|----|-----|-----|-----|-----|-----------------|-----|--------------|--------|
| Bolt Size | M12       | M18 | M20 | 1/2" | 9/16" | M10        | M12 | M16 | M20 | M6             | M8 | M10 | M12 | M16 | M20 | M24             | M20 | M24          | 1" UNF |
| Spanner   | 19        | 27  | 30  | 19   | 22    | 17         | 19  | 24  | 30  | 10             | 13 | 17  | 19  | 24  | 30  | 36              | 30  | 36           | 36     |
| Ft lb     | 69        | 221 | 265 | 102  | 142   | 12         | 21  | 53  | 104 | 7              | 16 | 32  | 57  | 140 | 273 | 472             | 389 | 660          | 931    |
| Nm        | 94        | 300 | 360 | 138  | 192   | 17         | 29  | 72  | 141 | 9              | 22 | 44  | 77  | 190 | 370 | 640             | 528 | 895          | 1262   |

[1] When fitting a wheel & tire to a hub, tighten the wheel nuts in a star pattern to the correct tension. To achieve this choose a wheel nut & tighten, then proceed to the opposite side of the hub to the next wheel nut & tighten & so on until all wheel nuts are tight. Then repeat the procedure to check that all nuts are tight. Do not use impact tools to tighten wheel nuts. For a guide to the correct tension of the wheel nuts please use the appropriate tension for your size wheel nuts from the Bolt Torque Settings table.

Torque values are for dry threads and surfaces however it is permissible to apply a small amount of anti corrosive oil to the threads.

Verification and recording of the prescribed torque settings in the table above is the responsibility of the assembler and it shall be documented in accordance with their approved Quality Assurance system.

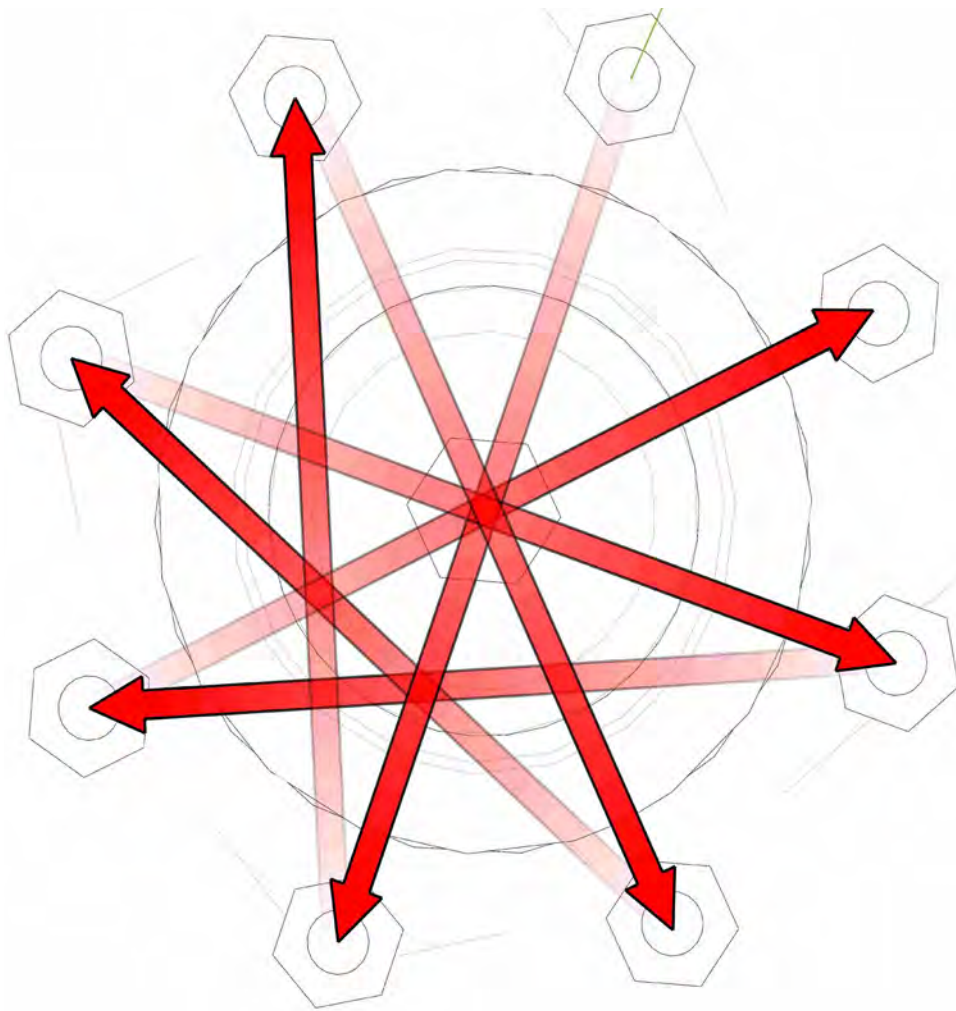





# Section 1 - Unpacking

We recommend the use of suitable lifting equipment with a lifting capacity of at least 4 tones.



## CAUTION

Take care when opening doors as load may have shifted or restraints may have broken.

- Remove boxes from doorway of container one at a time using a forklift truck. Each box weighs approximately (5512 lbs / 2500kg)
- Check strapping on each bundle before attempting to remove
- Attach chains to the packing frame using shackles and using suitable equipment (eg, forklift or tractor) drag framework bundles out of container. To move bundles away from front of container lift from side with forklift. Do not lift under angle iron frame, lift only under centre frame. Each bundle weighs approximately 7000 lb (3200 kg).

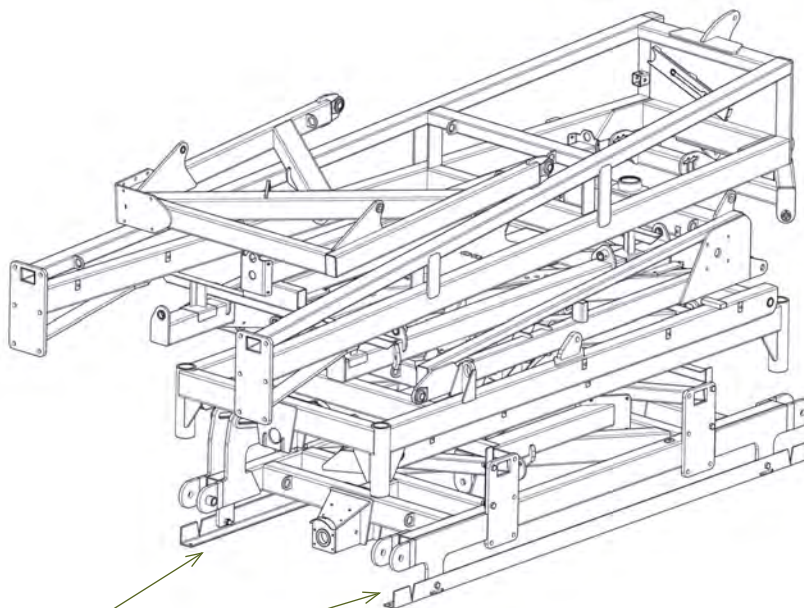

Connect chains to these points

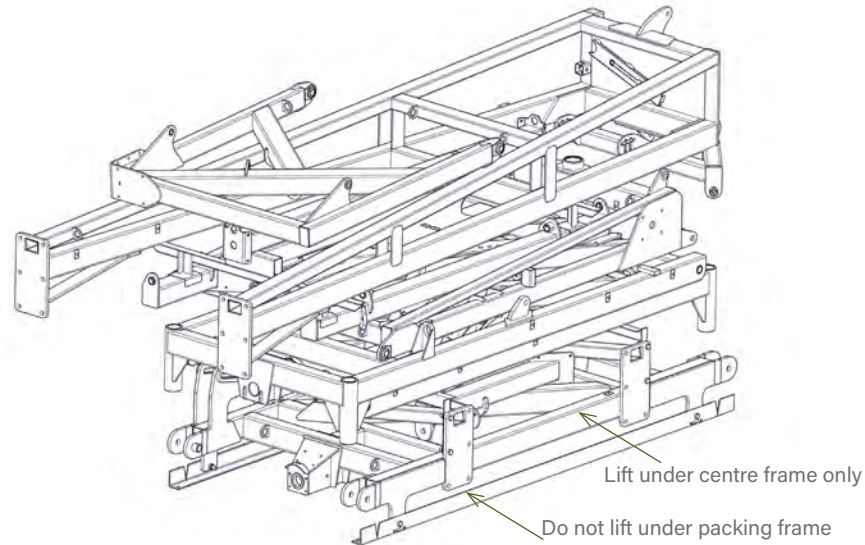

### CAUTION

Before cutting straps attach slings or chains and take the weight of the frames to avoid them slipping or falling and causing injury.



### CAUTION

Wear eye and hand protection when cutting straps. Sharp edges are exposed as straps separate and may cause injury.



### CAUTION

To avoid falling or moving components, before cutting straps attach slings or chains to individual pieces and only cut the straps holding the piece to be lifted.

- Remove boxes from rear of container one at a time using a forklift truck. Each box weighs approximately 5512 lbs (2500 kg)
- Cut straps holding bundles and separate parts and place in assembly area
- Once all parts have been identified, the machine is ready for assembly
- Identify parts for each machine by serial no. or description and separate. Open parts box and check that all parts are accounted for against checklist
- Read assembly instructions before proceeding.

**NOTE**

Keep 0801-10-08-175 pins when unpacking for machine assembly (refer to page 45).

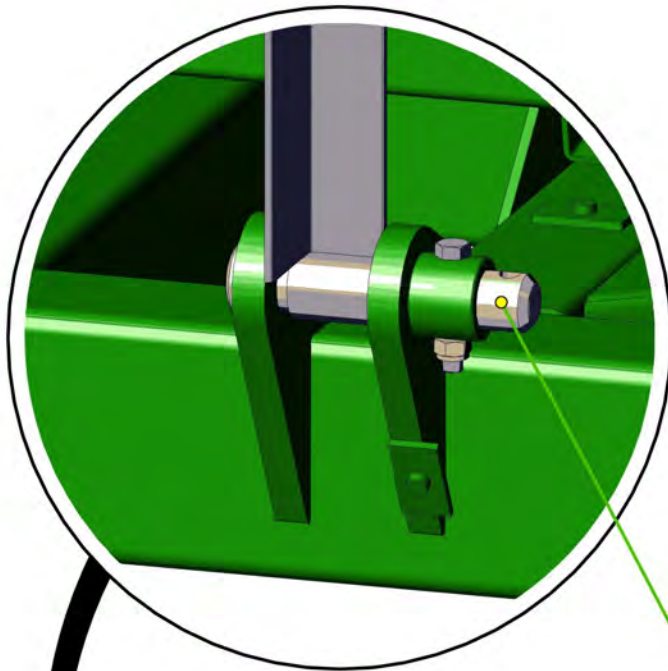

Pin 0801-10-08-175

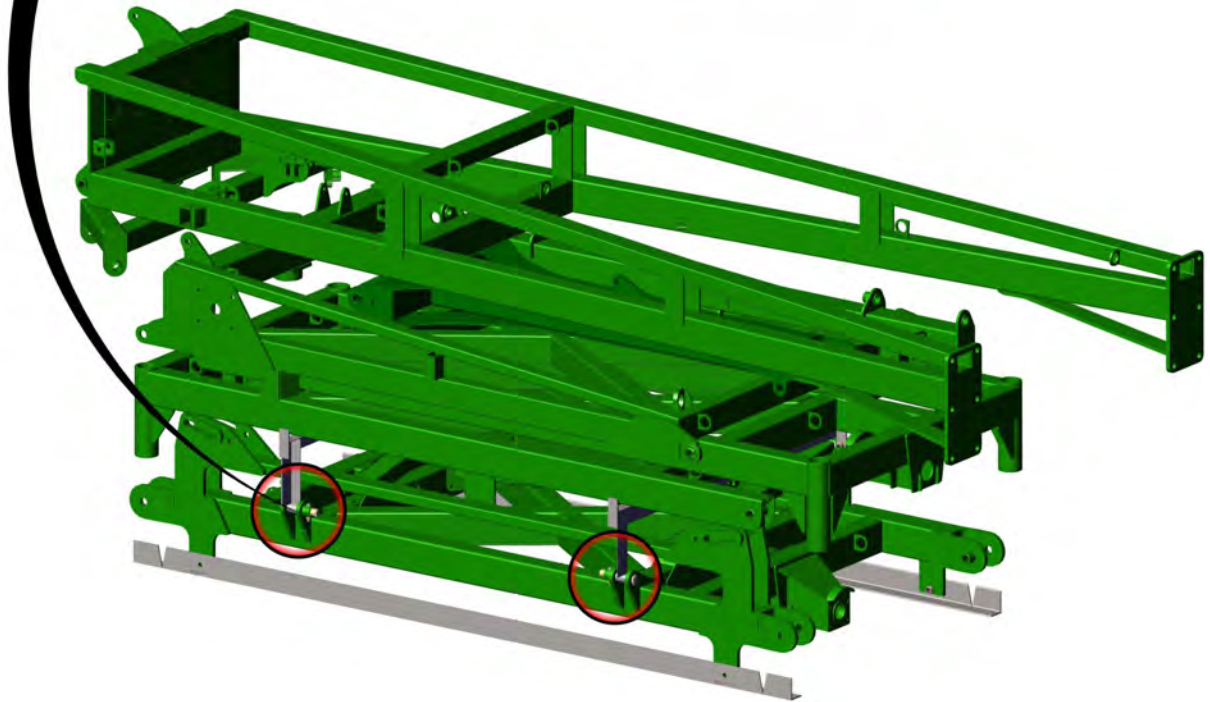

**NOTE**

The hubs show below are interchangeable (refer to page 12 for assembly).

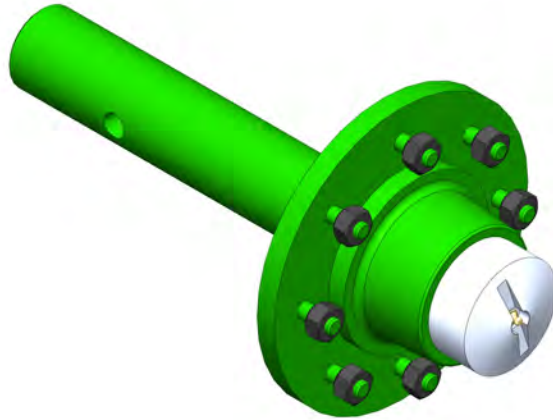

0733-SH27596880

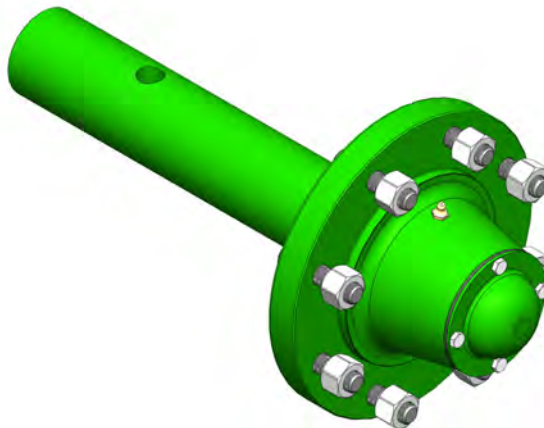

0733-LG6080067



# Section 2 - Assembly

| Item No. | Description      | Number    | Qty |
|----------|------------------|-----------|-----|
| 1        | 30' Centre Frame | 0830-01-2 | 1   |

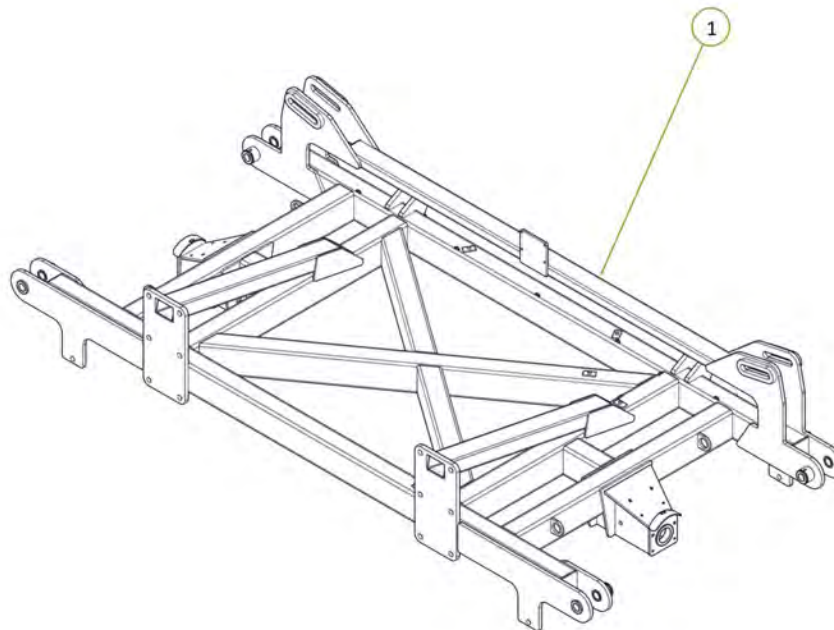



| Item No. | Description                | Number         | Qty    |
|----------|----------------------------|----------------|--------|
| 1        | 30' Left Hand Wing         | 0830-07-2      | 1      |
| 2        | PCH Wing Pivot Pin         | 0801-10-08-235 | 2      |
| 3        | Cotter Pin M13 x 63        | 0261-PINC1363  | 2      |
| 4        | 35 ID x 30mm DU Bush       | 0113-MB3530DU  | 4 </td |
| 5        | M12 x 90 Class 8.8 ZP Bolt | 0211-1290      | 2      |
| 6        | Nyloc Nut M12              | 0221-NYL12     | 2      |

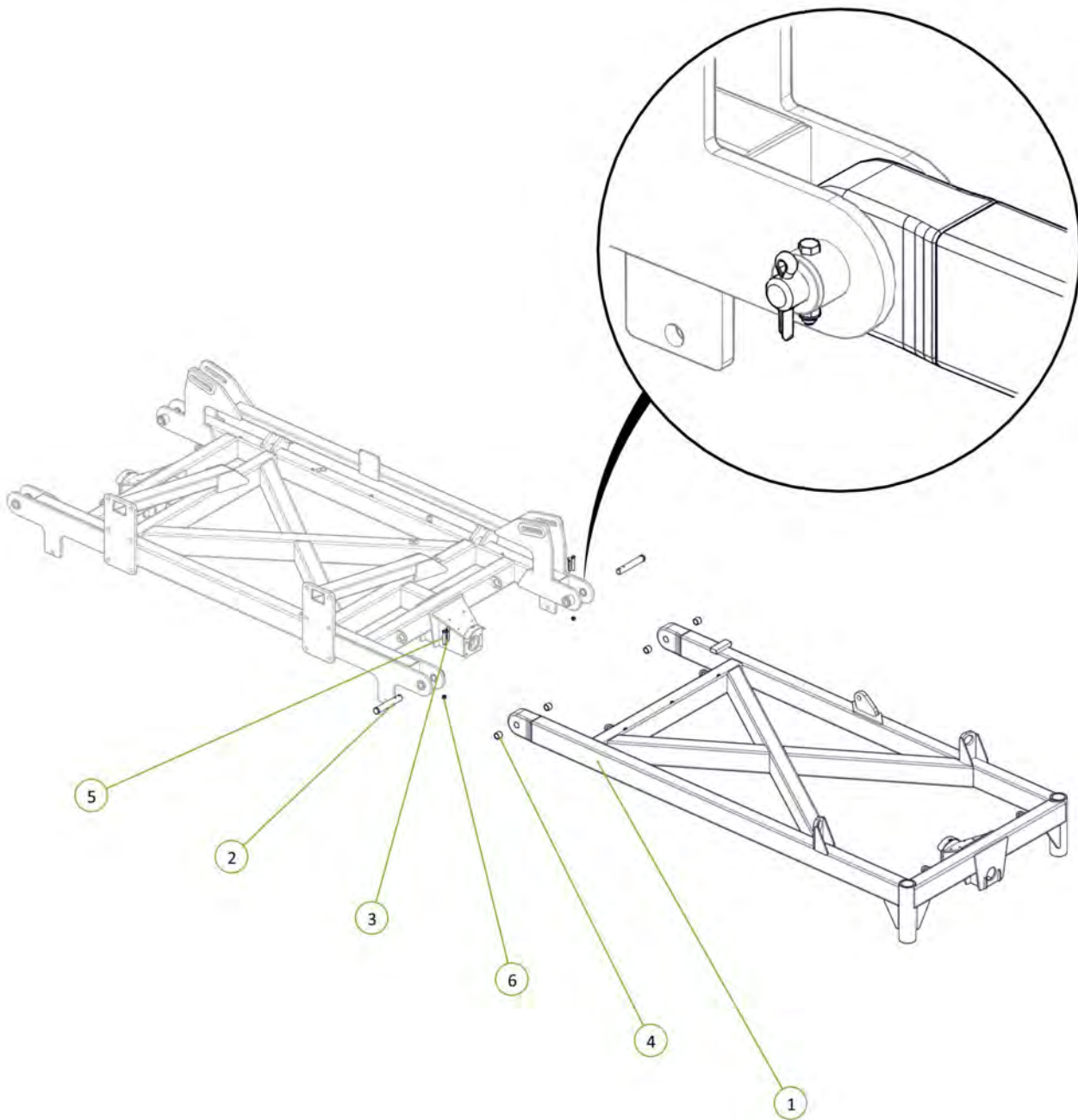

| Item No. | Description                | Number         | Qty |
|----------|----------------------------|----------------|-----|
| 1        | 30' Right Hand Wing        | 0830-06-2      | 1   |
| 2        | PCH Wing Pivot Pin         | 0801-10-08-235 | 2   |
| 3        | 35 ID x 30mm DU Bush       | 0113-MB3530DU  | 4   |
| 4        | Cotter Pin M13 x 63        | 0261-PINC1363  | 2   |
| 5        | M12 x 90 Class 8.8 ZP Bolt | 0211-1290      | 2   |
| 6        | Nyloc Nut M12              | 0221-NYL12     | 2   |

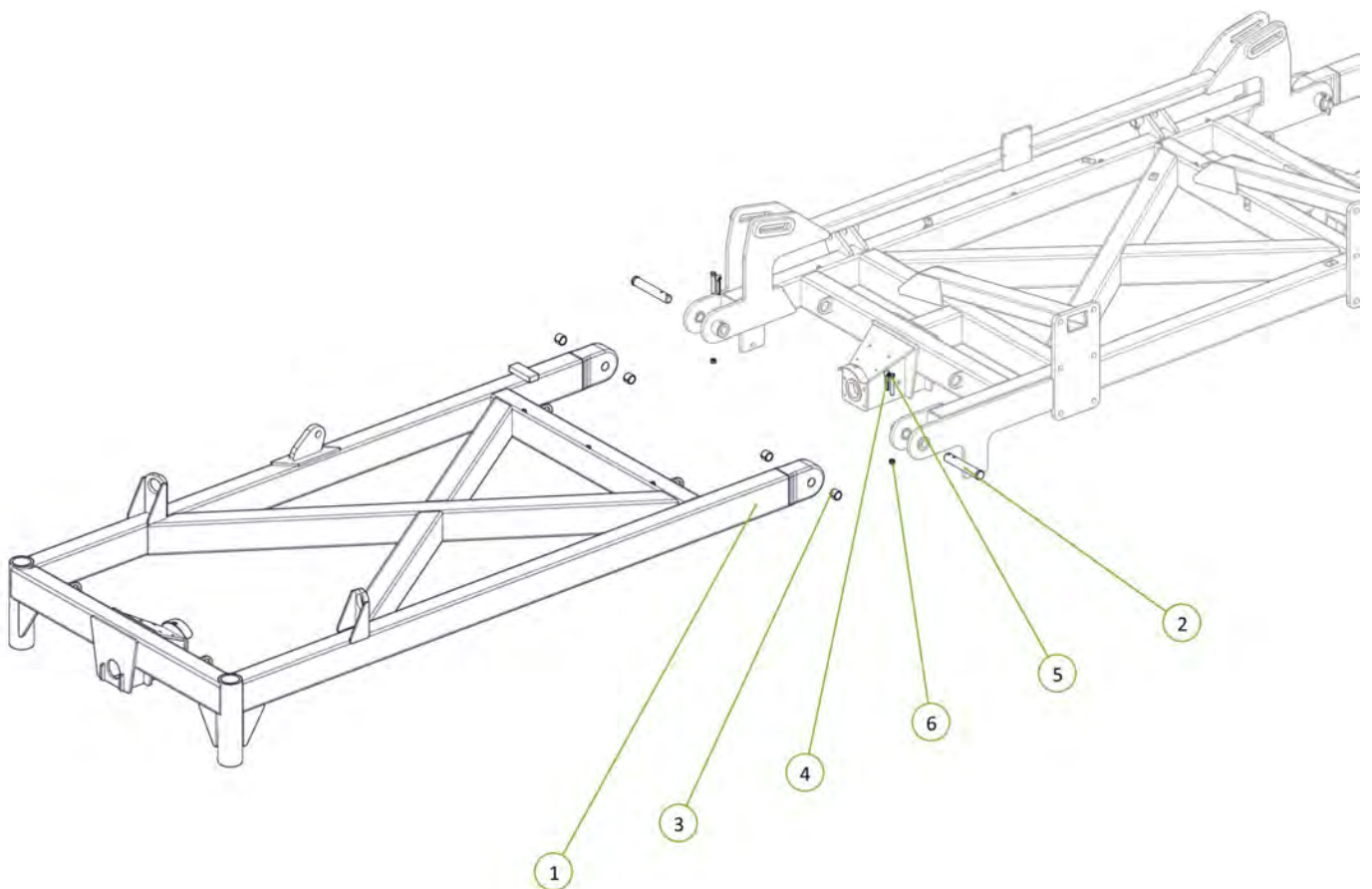



| Item No. | Description   | Number         | Qty |
|----------|---|----------------|-----|
| 1        | 2.75"R C/W 6 tonne 8 on 8" PCD Complete Assembly inc GS | 0733-LG6080067 | 4   |
| 2        | M20 x 170 grade 8.8 ZP Bolt                             | 0211-20170     | 4   |
| 3        | Nyloc Nut M20   | 0221-NYL20     | 4   |
| 4        | Washer Flat M20   | 0231-F20       | 8   |

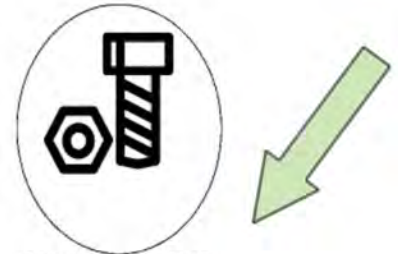

0802-FK-0830-01A-AS1-USA  
0802-FK-0830-06A-AS1-USA  
0802-FK-0830-07A-AS1-USA

Use threads to rear of machine for protection

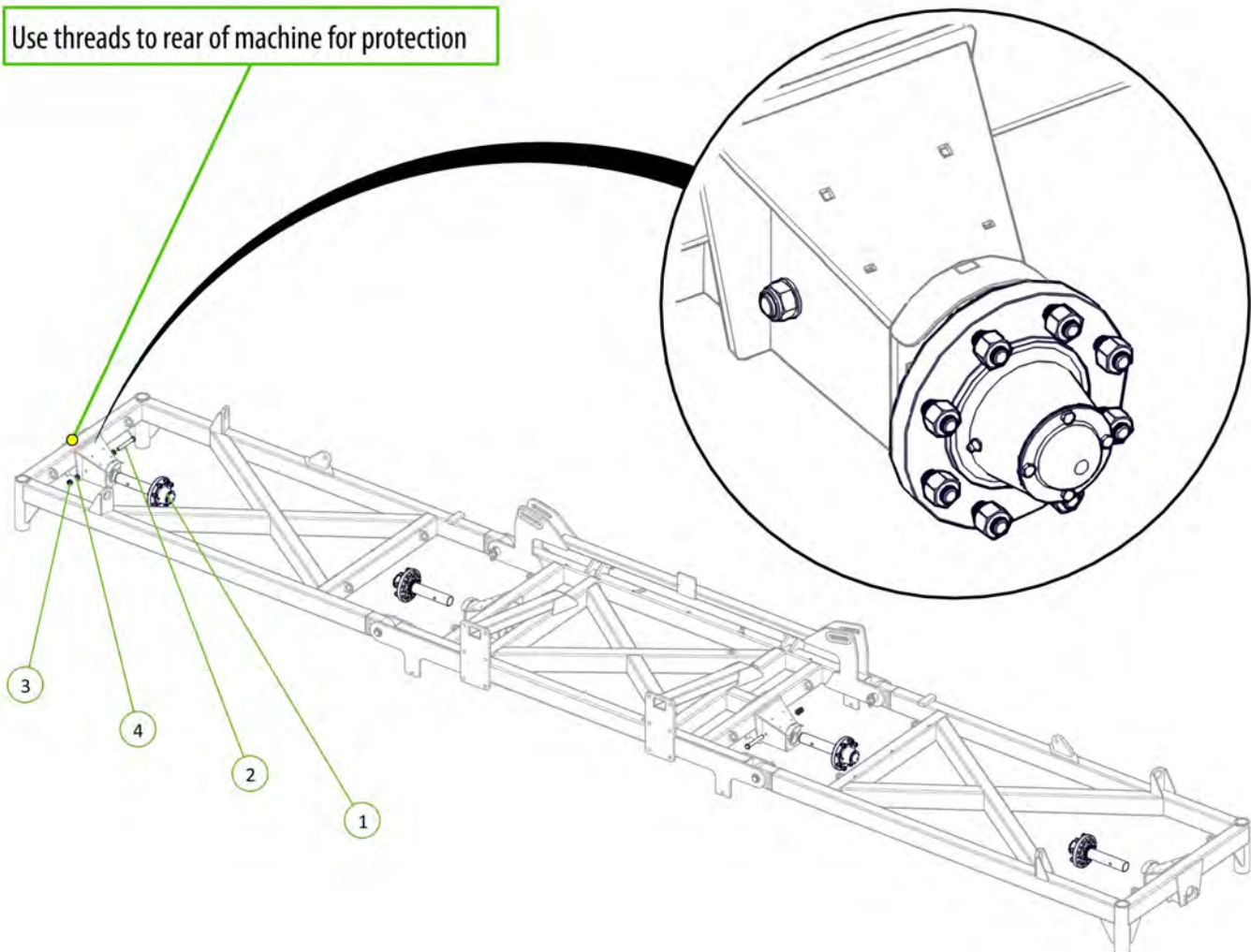

## NOTE

The hub (0733-SH27596880) showed on item one is interchangeable. (Refer to page 8 for more information).

| Item No. | Description                             | Number      | Qty |
|----------|---|-------------|-----|
| 1        | Dual Circuit Single Sequence Block Body | 0802-690507 | 1   |
| 2        | M10 x 25 grade 8.8 ZP Bolt              | 0211-1025   | 4   |
| 3        | Washer Flat M10                         | 0231-F10    | 4   |
| 4        | Washer Spring M10                       | 0231-S10    | 4   |

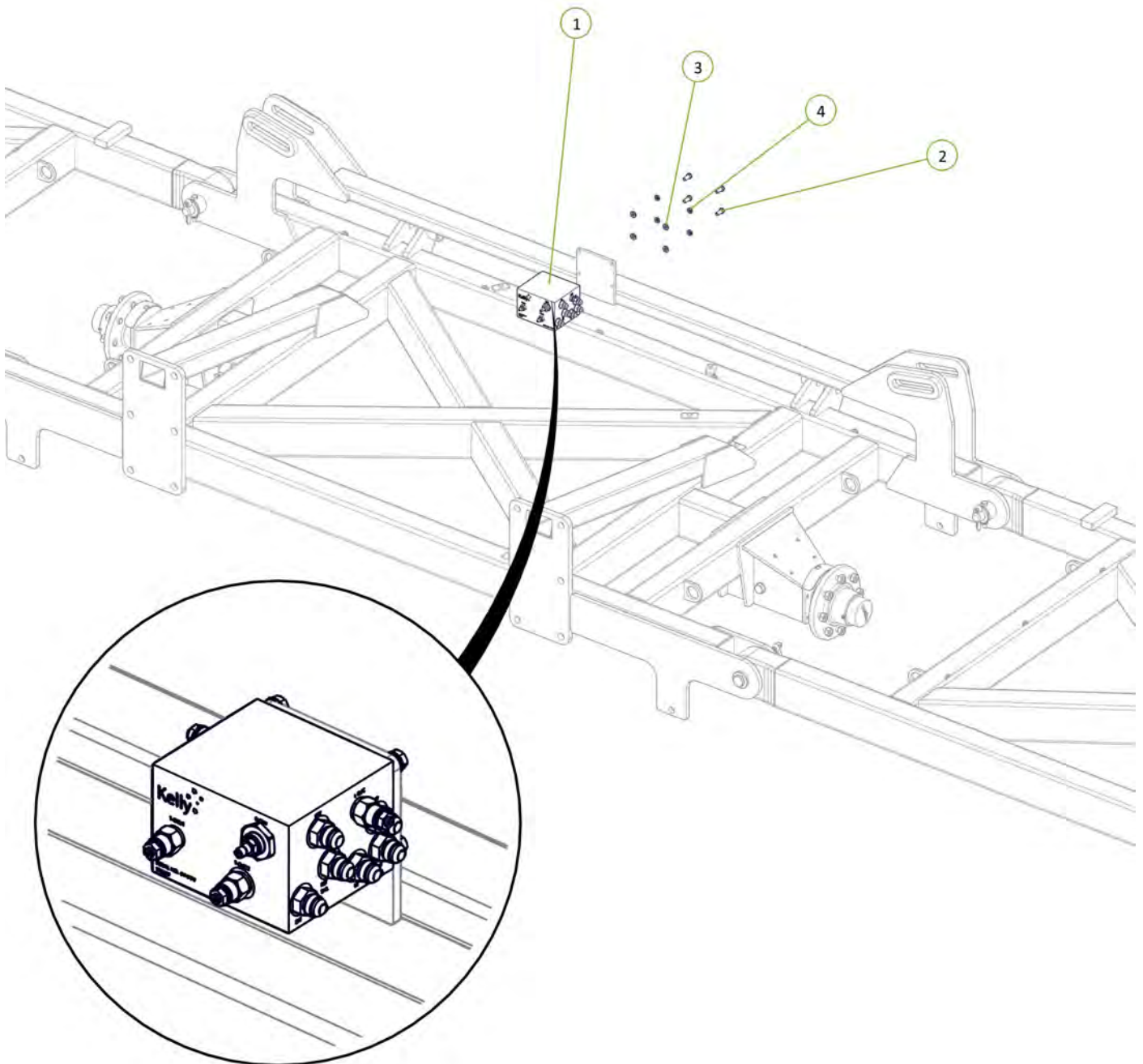

| Item No. | Description   | Number     | Qty |
|----------|---|------------|-----|
| 1        | 4" Bore 30" Stroke 3" S/Tube 1.75" Rod Hydraulic Cylinder | 0311-430ST | 2   |

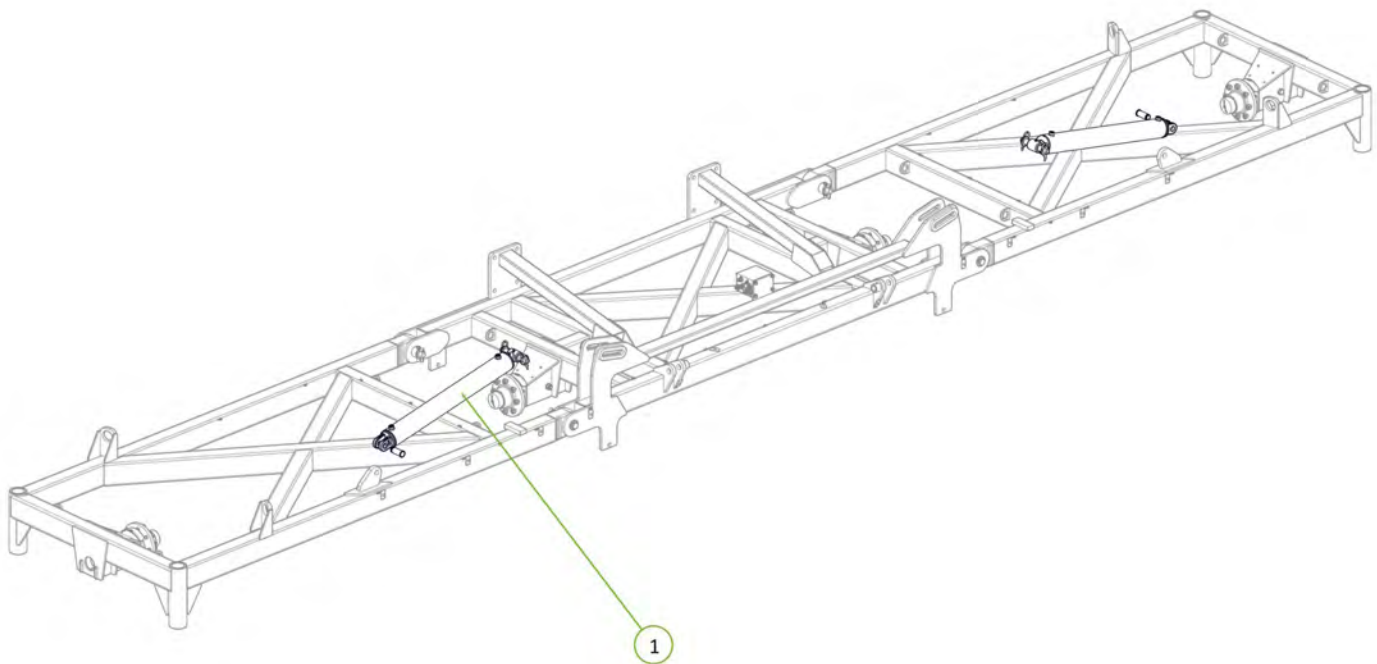
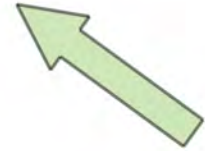

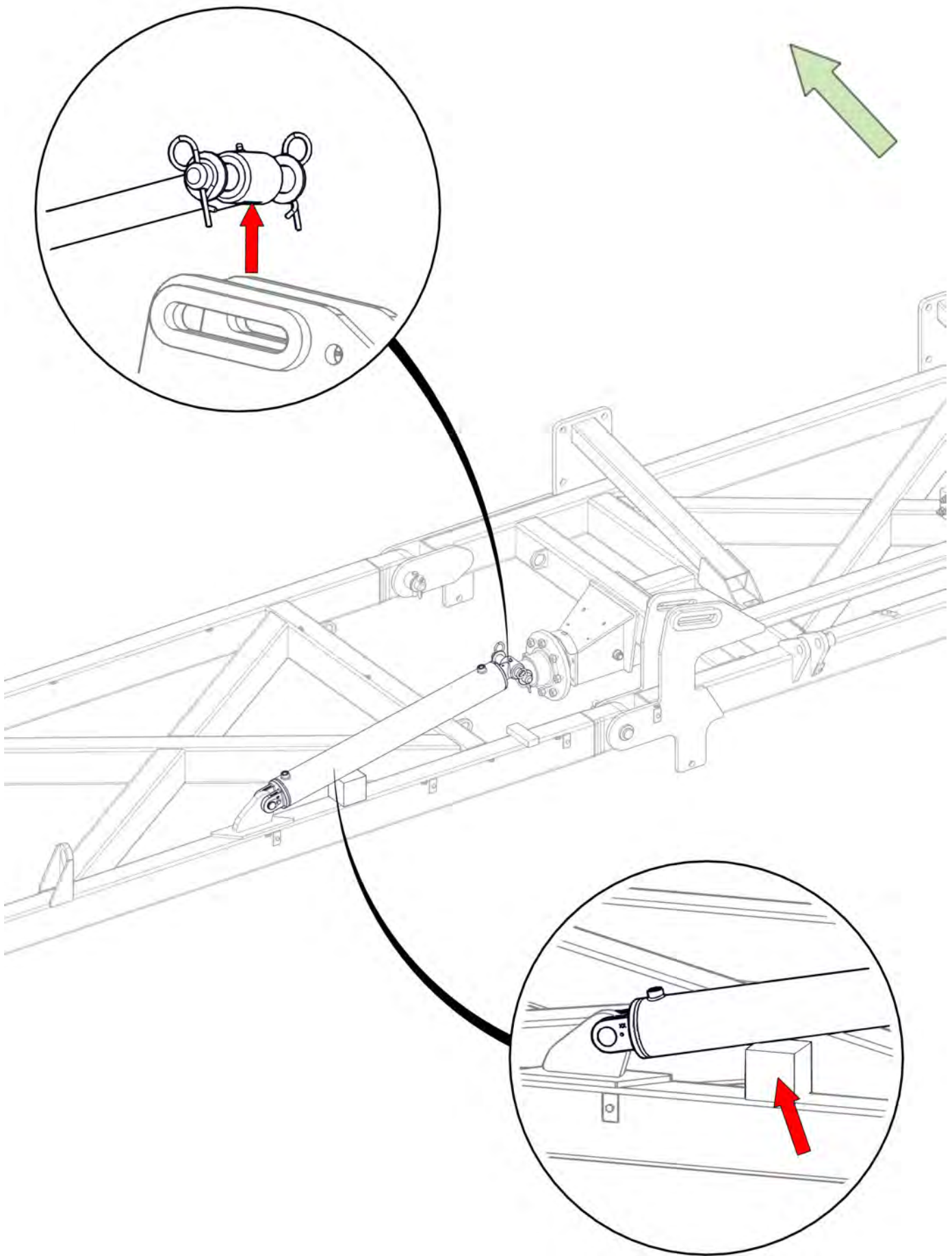



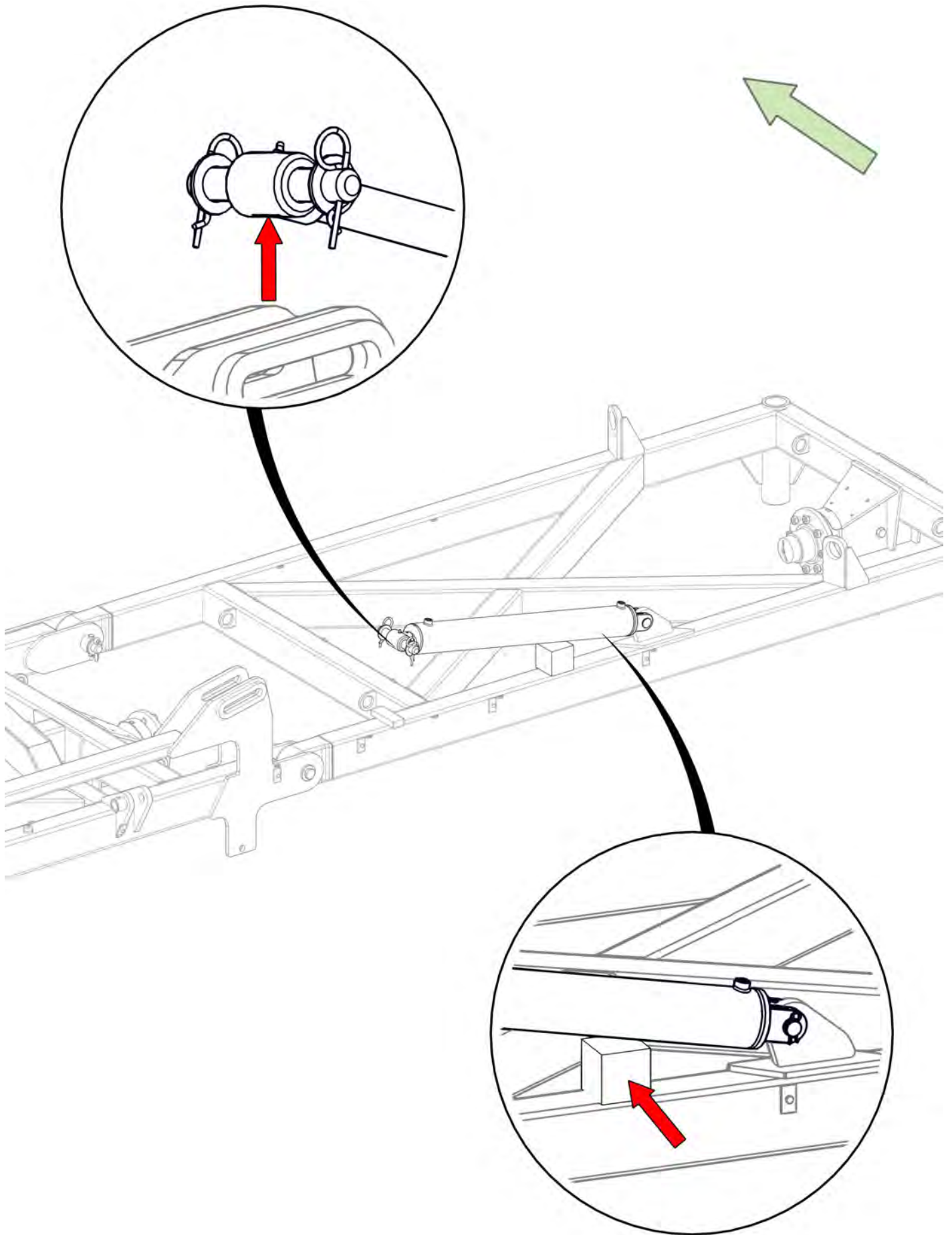

| Item No. | Description                                 | Number        | Qty |
|----------|---|---------------|-----|
| 1        | 3/4" JIC Male 3/4" UN O Ring Male 90° Elbow | 0323-S91-1212 | 2   |

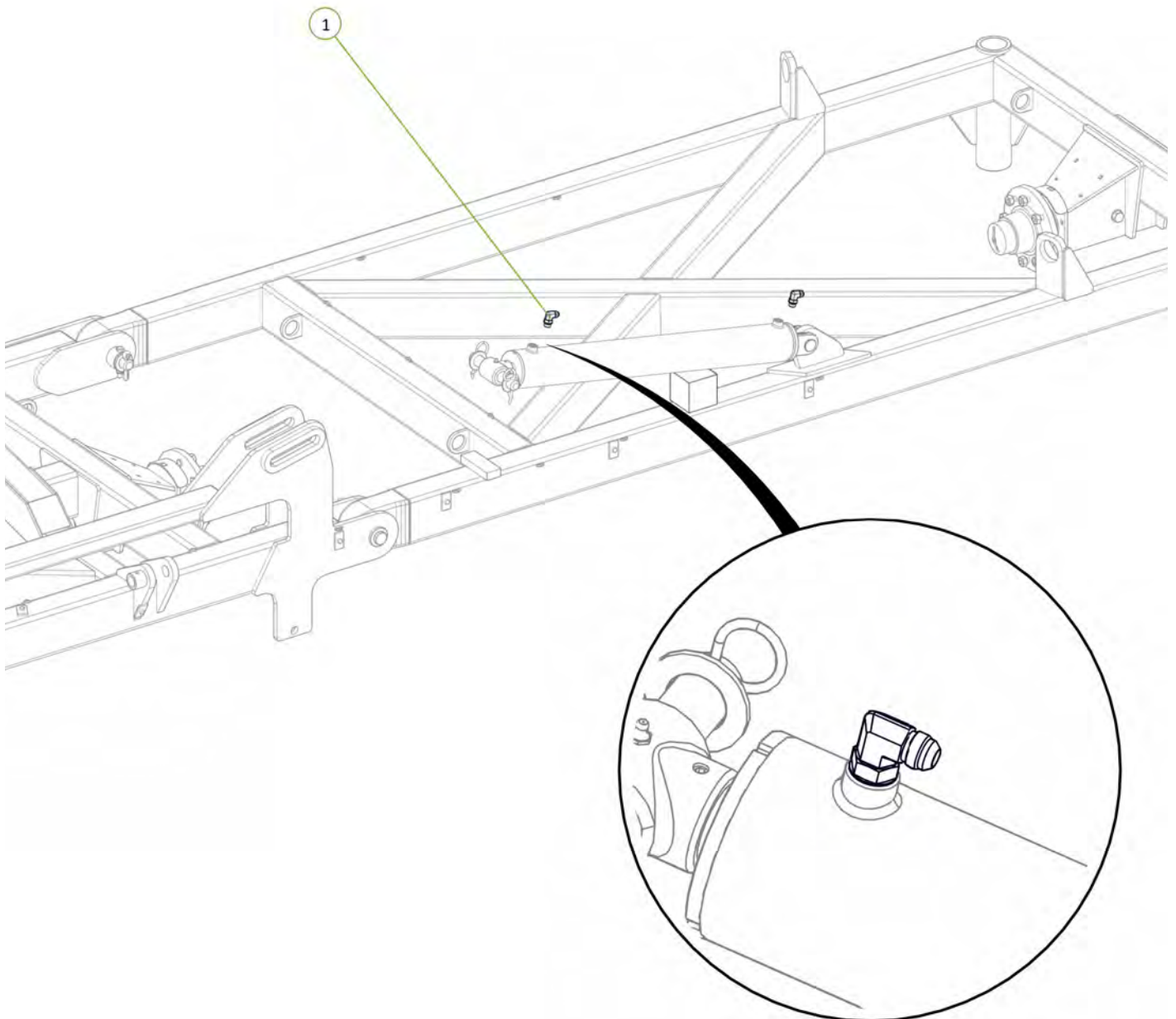

| Item No. | Description   | Number           | Qty |
|----------|---|------------------|-----|
| 1        | 1/2" BSPP Encapt Male 3/4" JIC Female Swive Adaptor | 0323-S71-0812    | 1   |
| 2        | Ball Valve BSPP 1/2"                                | 0341-RL20SH-0808 | 1   |
| 3        | 1/2" BSPP Encapt Male 3/4" JIC Male Adaptor         | 0323-S74-0812    | 1   |

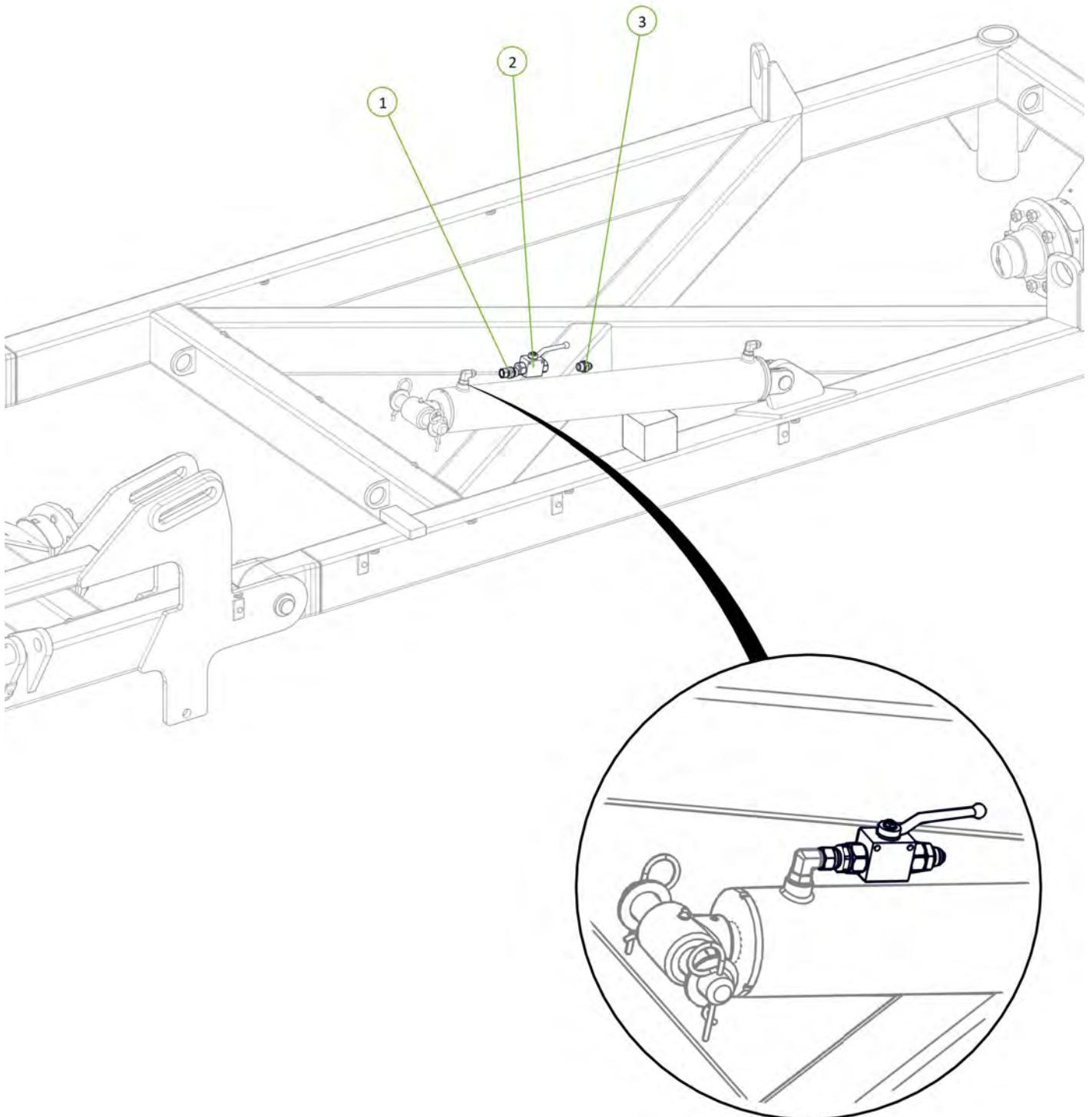



| Item No. | Description                            | Number          | Qty |
|----------|--|-----------------|-----|
| 1        | Double Clamp Bolt Group 2              | 0325-RCD-2BH    | 1   |
| 2        | Clamp top plate group 2                | 0325-RCD-2PT    | 1   |
| 3        | 17mm Clamp Jaws (Pair)                 | 0325-RCD-17J    | 2   |
| 4        | Double Clamp Stacking Plate (Non Ryco) | 0325-SI-2-5D-W3 | 1   |
| 5        | Double Clamp Stacking Bolt Group 2     | 0325-RCD-2BS    | 1   |

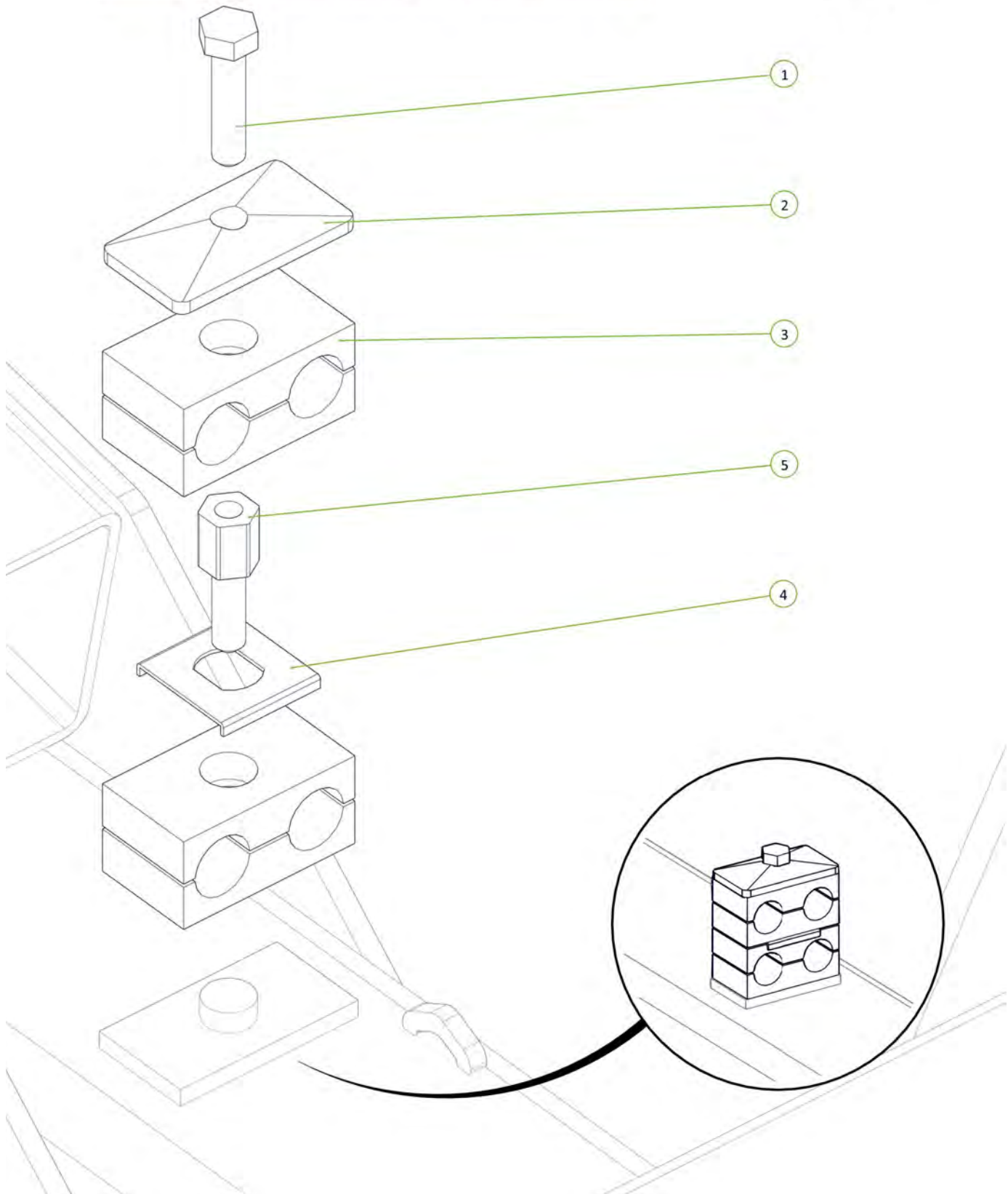

| Item No. | Description                                 | Number   | Qty |
|----------|---|----------|-----|
| 1        | Valve RE Port to RH Wing Cylinder Rear Port | PH30S-20 | 1   |
| 2        | Valve RR Port to RH Wing Cylinder Rod Port  | PH30S-22 | 1   |

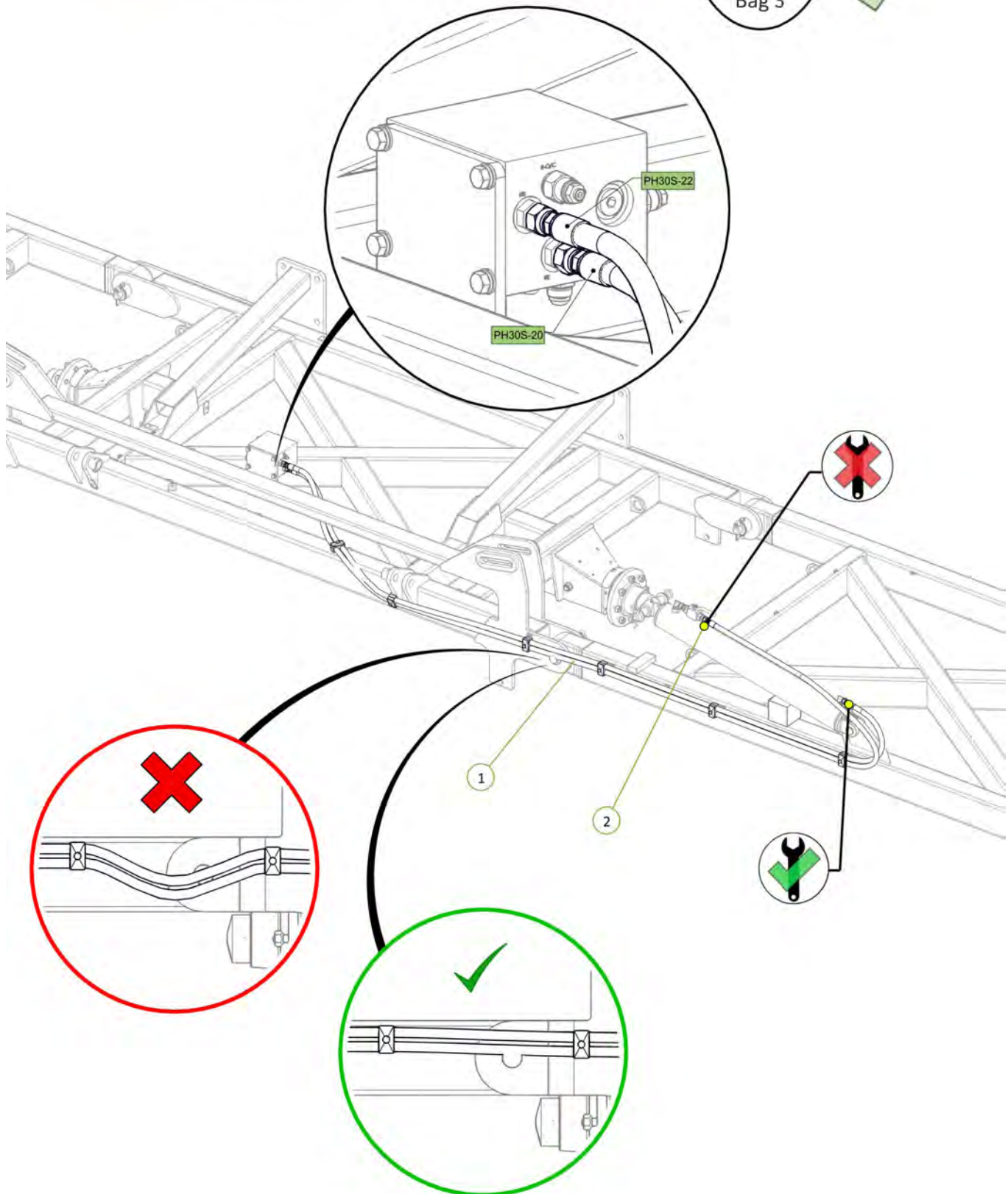

| Item No. | Description                                 | Number        | Qty |
|----------|---|---------------|-----|
| 1        | 3/4" JIC Male 3/4" UN O Ring Male 90° Elbow | 0323-S91-1212 | 2   |

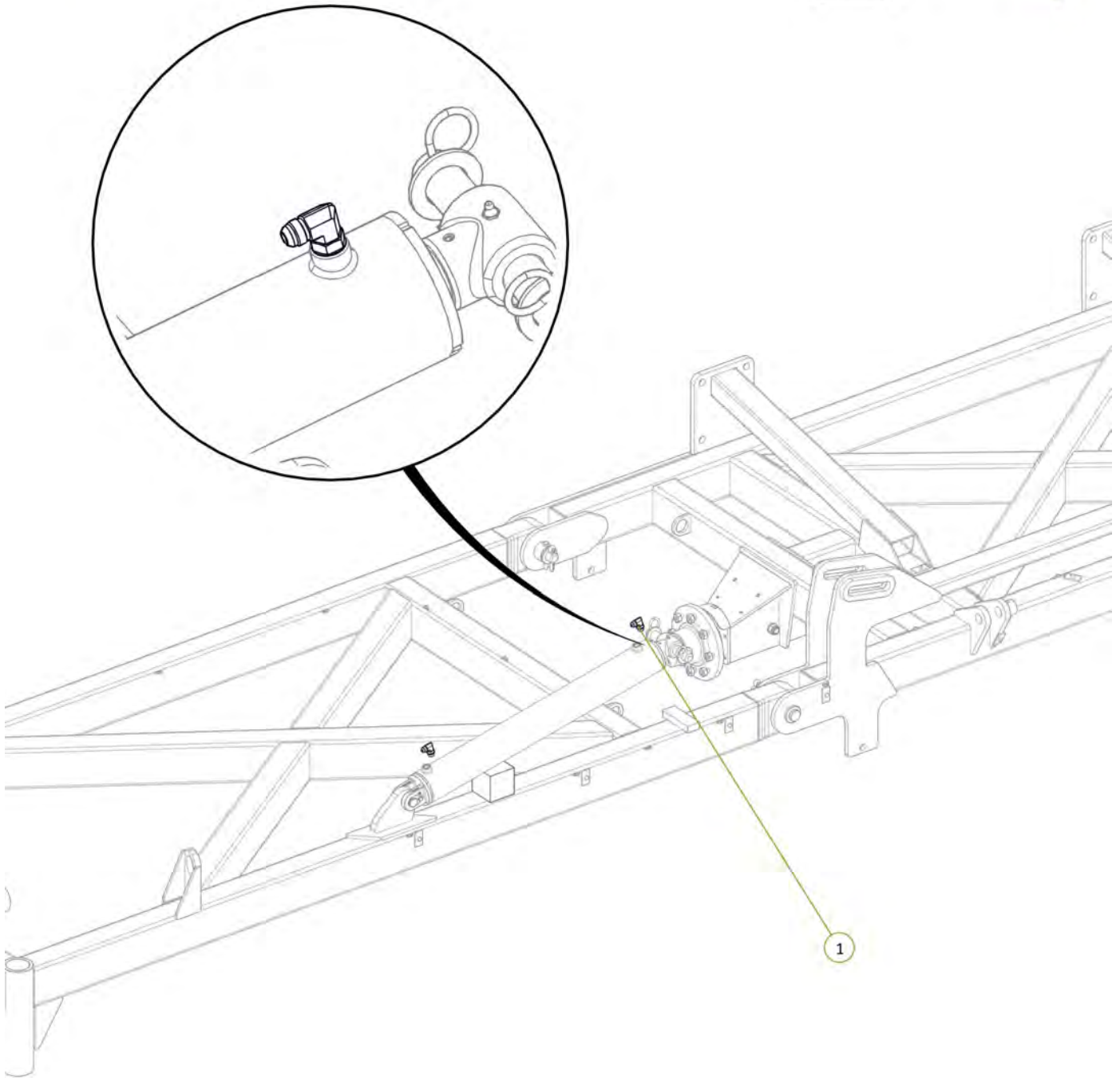



| Item No. | Description   | Number           | Qty |
|----------|---|------------------|-----|
| 1        | 1/2" BSPP Encapt Male 3/4" JIC Female Swive Adaptor | 0323-S71-0812    | 1   |
| 2        | Ball Valve BSPP 1/2"                                | 0341-RL20SH-0808 | 1   |
| 3        | 1/2" BSPP Encapt Male 3/4" JIC Male Adaptor         | 0323-S74-0812    | 1   |

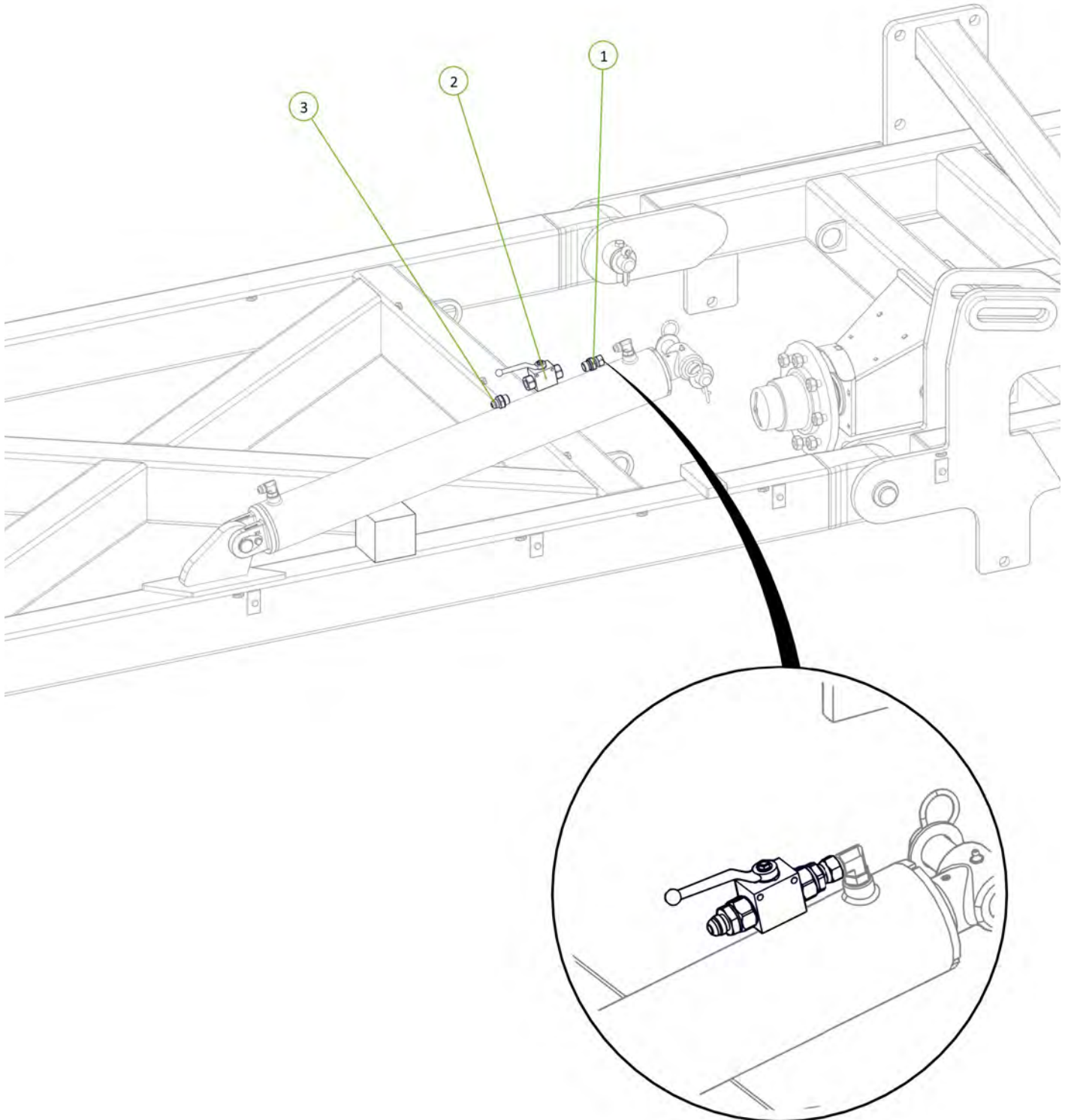

| Item No. | Description                                 | Number   | Qty |
|----------|---|----------|-----|
| 1        | Valve LE Port to LH Wing Cylinder Rear Port | PH30S-19 | 1   |
| 2        | Valve LR Port to LH Wing Cylinder Rod Port  | PH30S-21 | 1   |

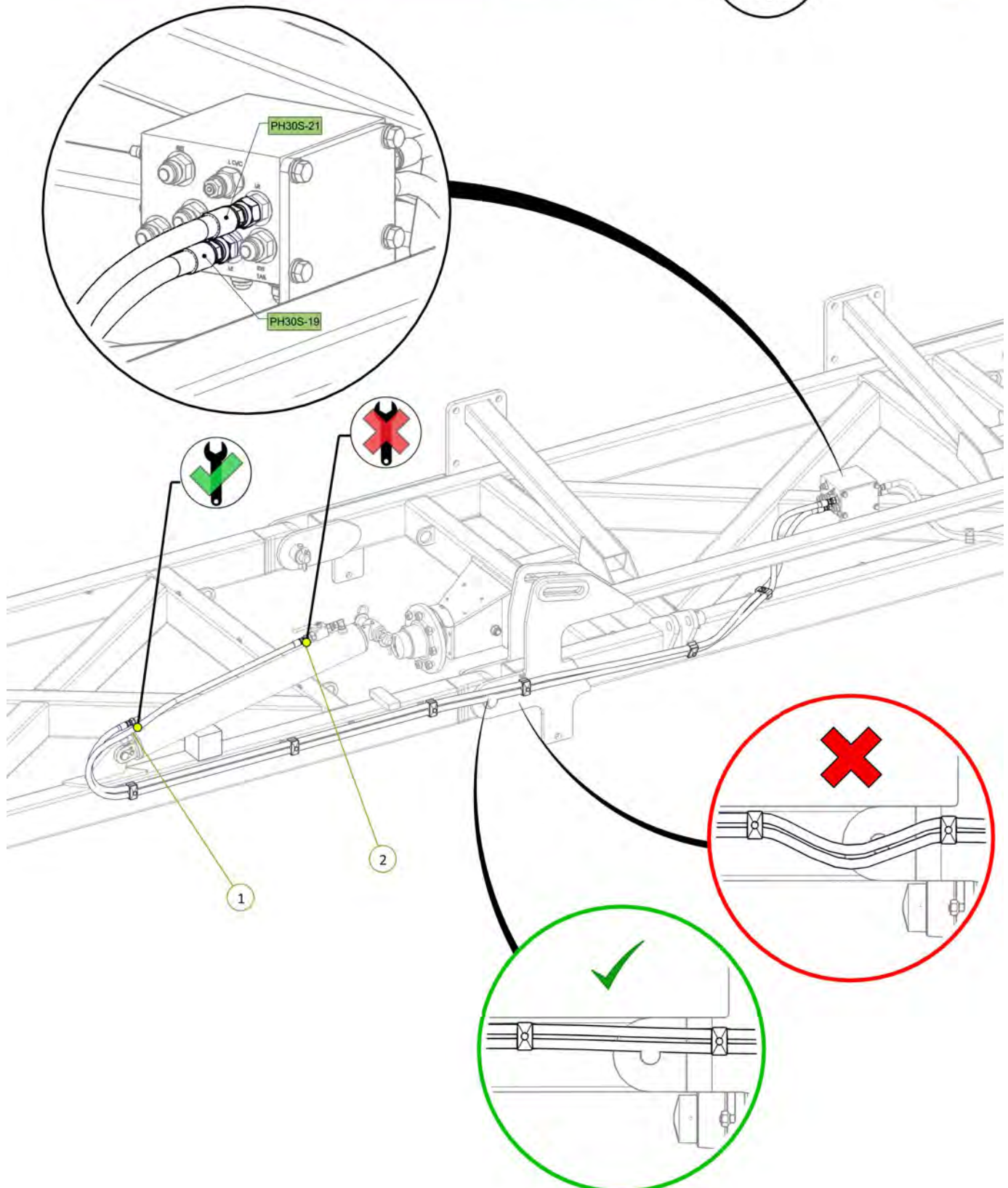

| Item No. | Description   | Number         | Qty |
|----------|---|----------------|-----|
| 1        | 1/2" BSPP Encapt Male 3/4" JIC Female Swive Adaptor | 0323-S71-0812  | 2   |
| 2        | In Line Hydraulic Oil Filter                        | 0343-924001261 | 2   |
| 3        | 1/2" BSPP Encapt Male 3/4" JIC Male Adaptor         | 0323-S74-0812  | 2   |

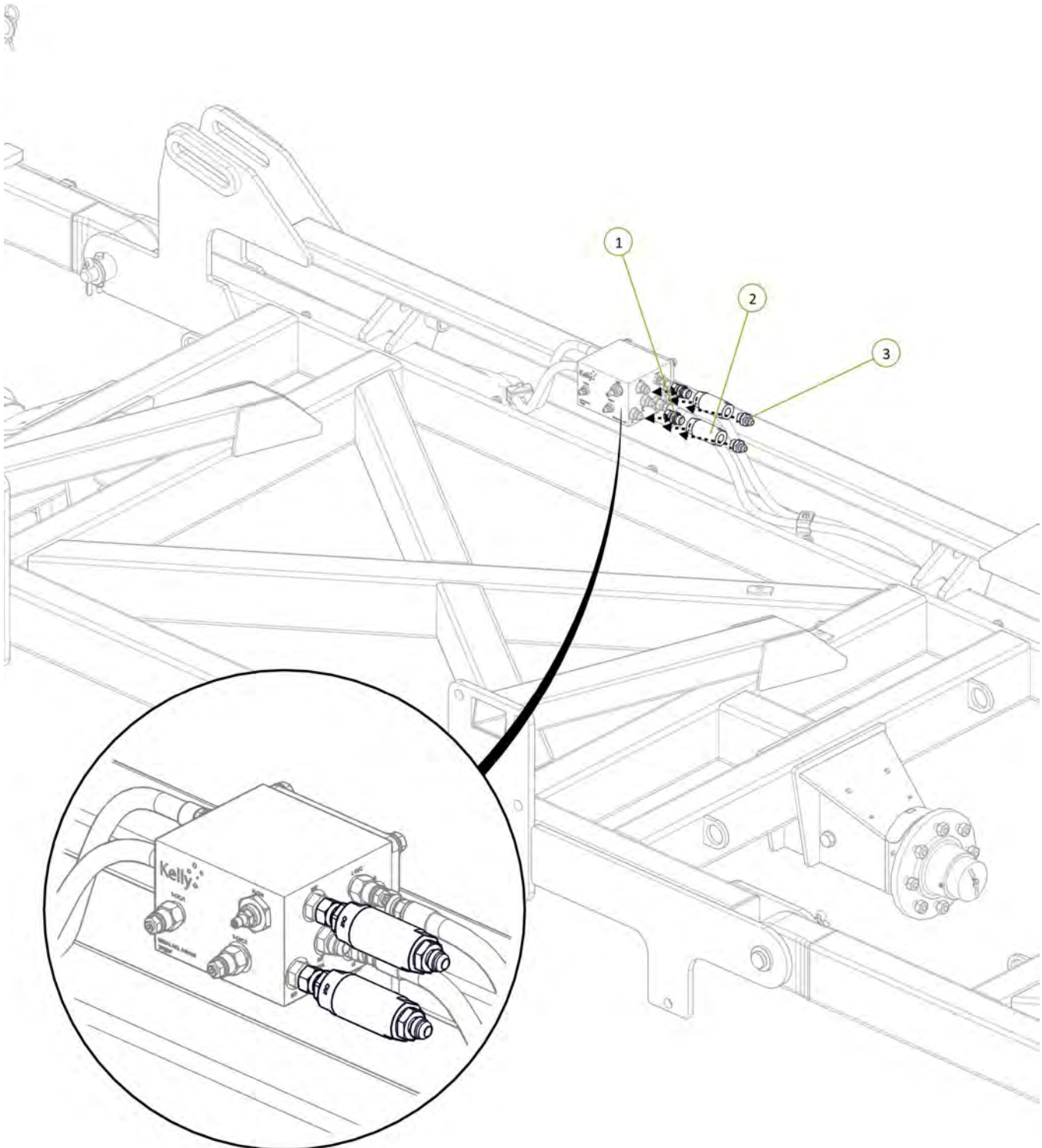



| Item No. | Description  | Number          | Qty |
|----------|--|-----------------|-----|
| 1        | Tractor to Sequence Valve EXT Port fitted with Green Extend Decal  | PH30S-01-GE-EXT | 1   |
| 2        | Tractor to Sequence Valve RCT Port fitted with Green Retract Decal | PH30S-01-GR-RCT | 1   |

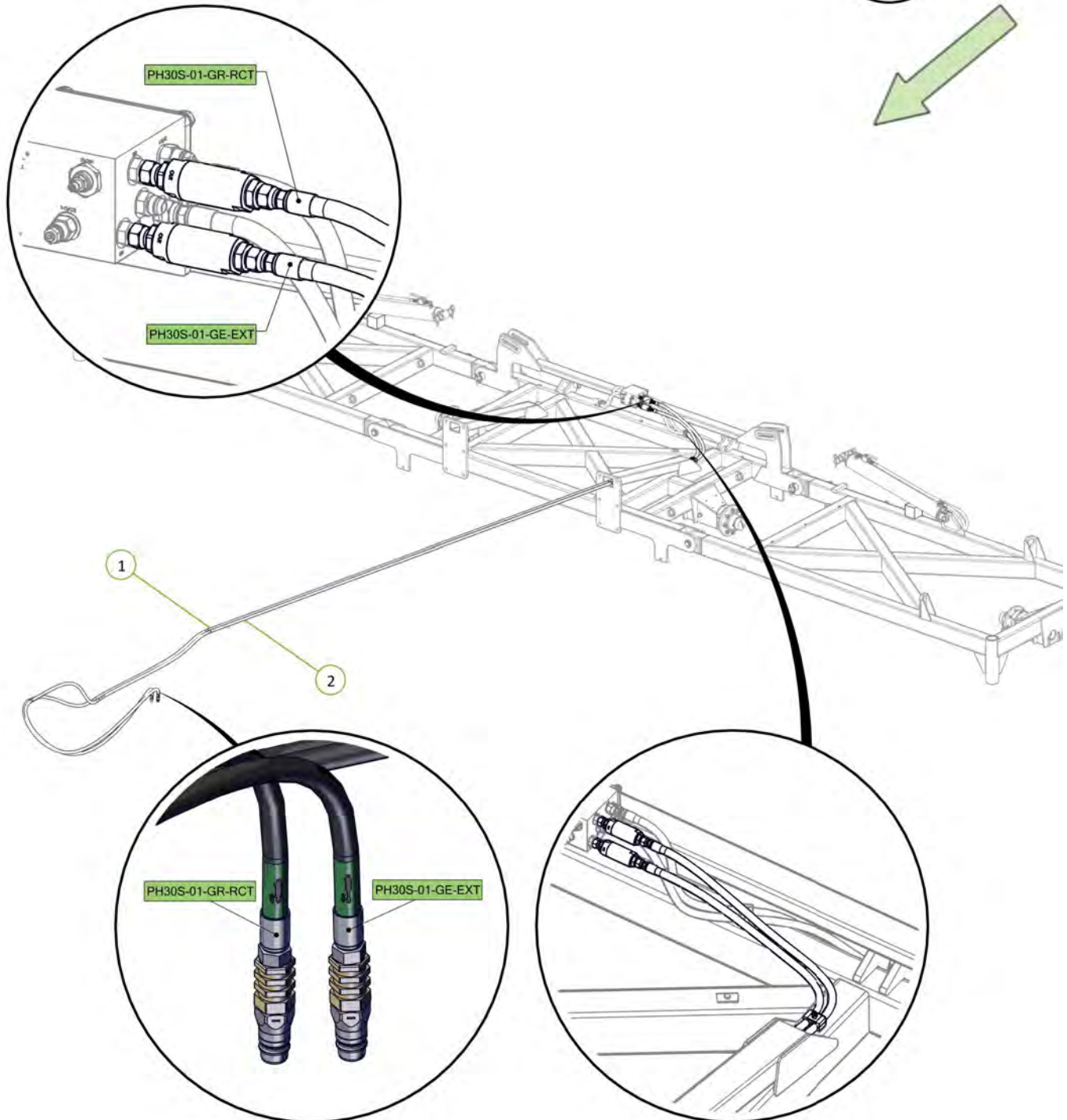

Ensure retract hose fittings are loose to allow air to escape

Check cylinders are chocked up to prevent clashing during extension



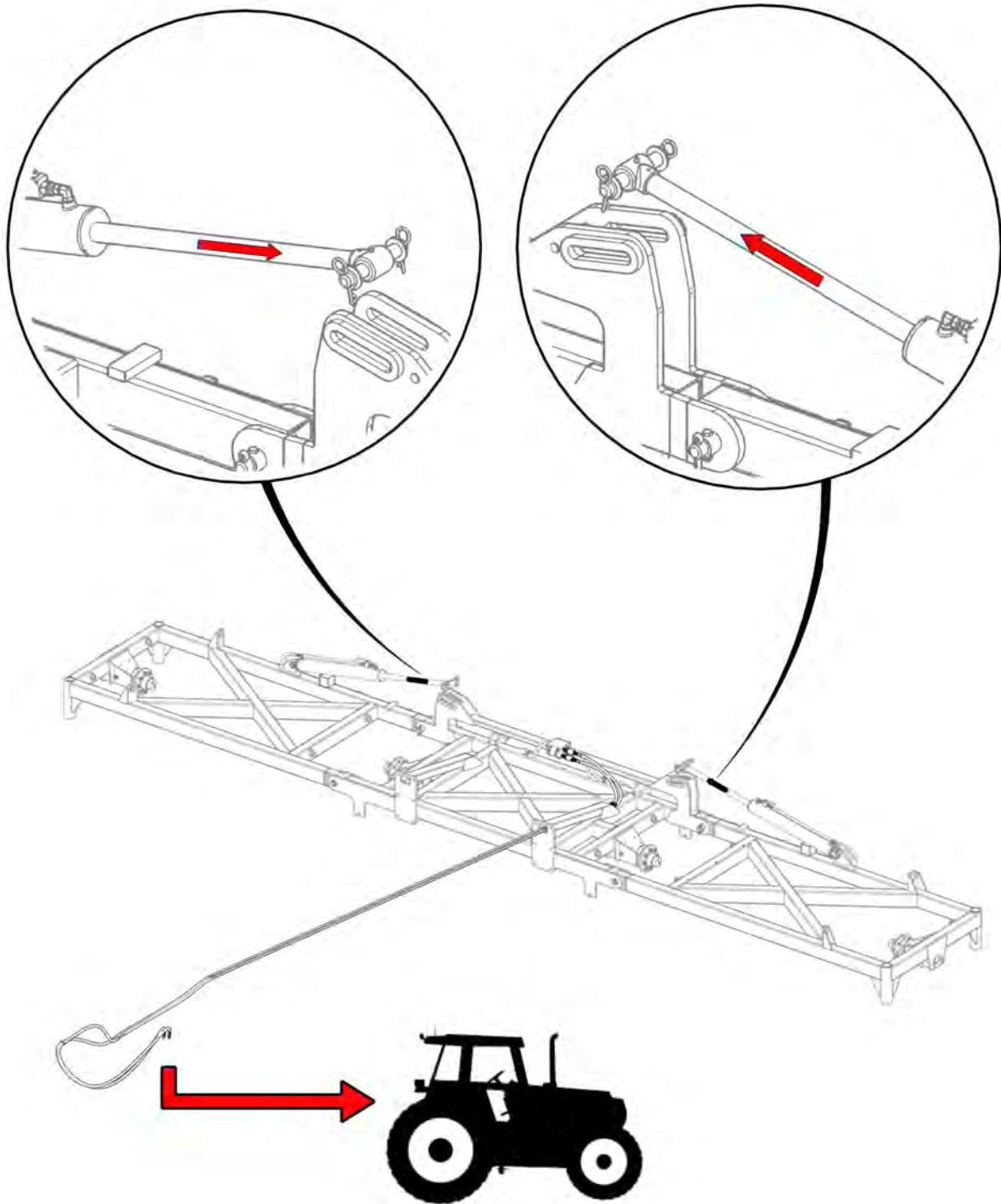

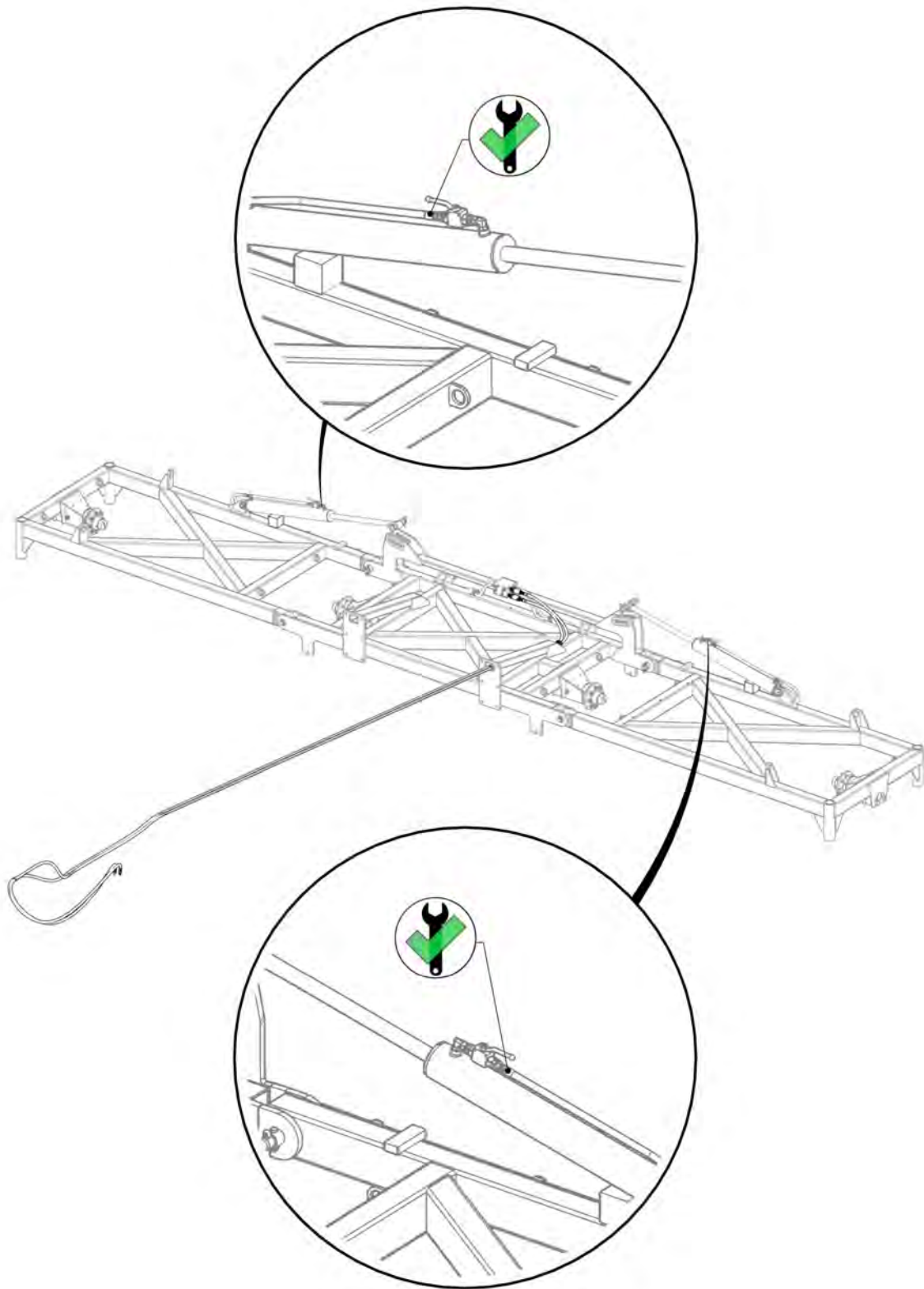

Tighten retract fittings

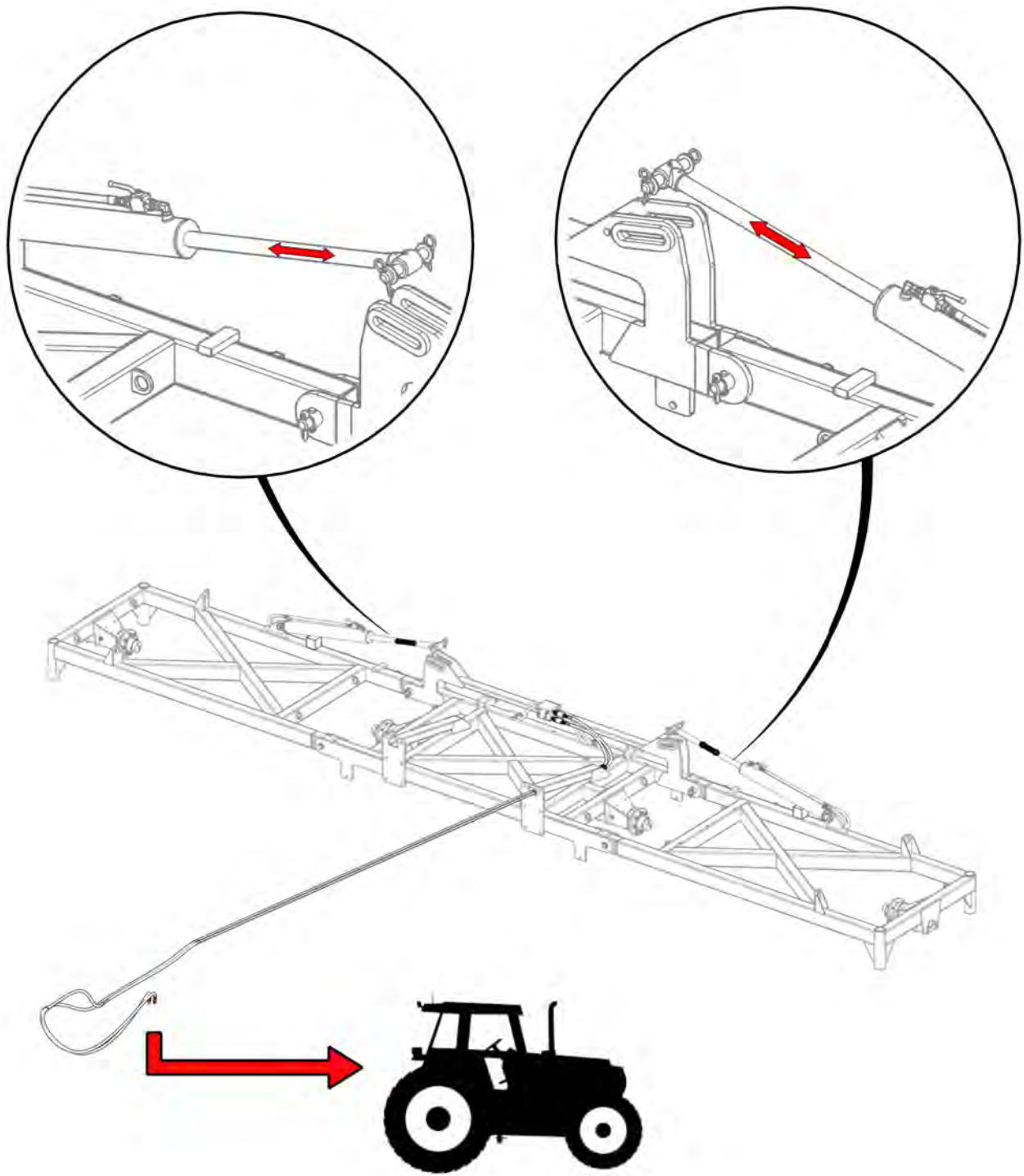

Cycle cylinders to expel air from system

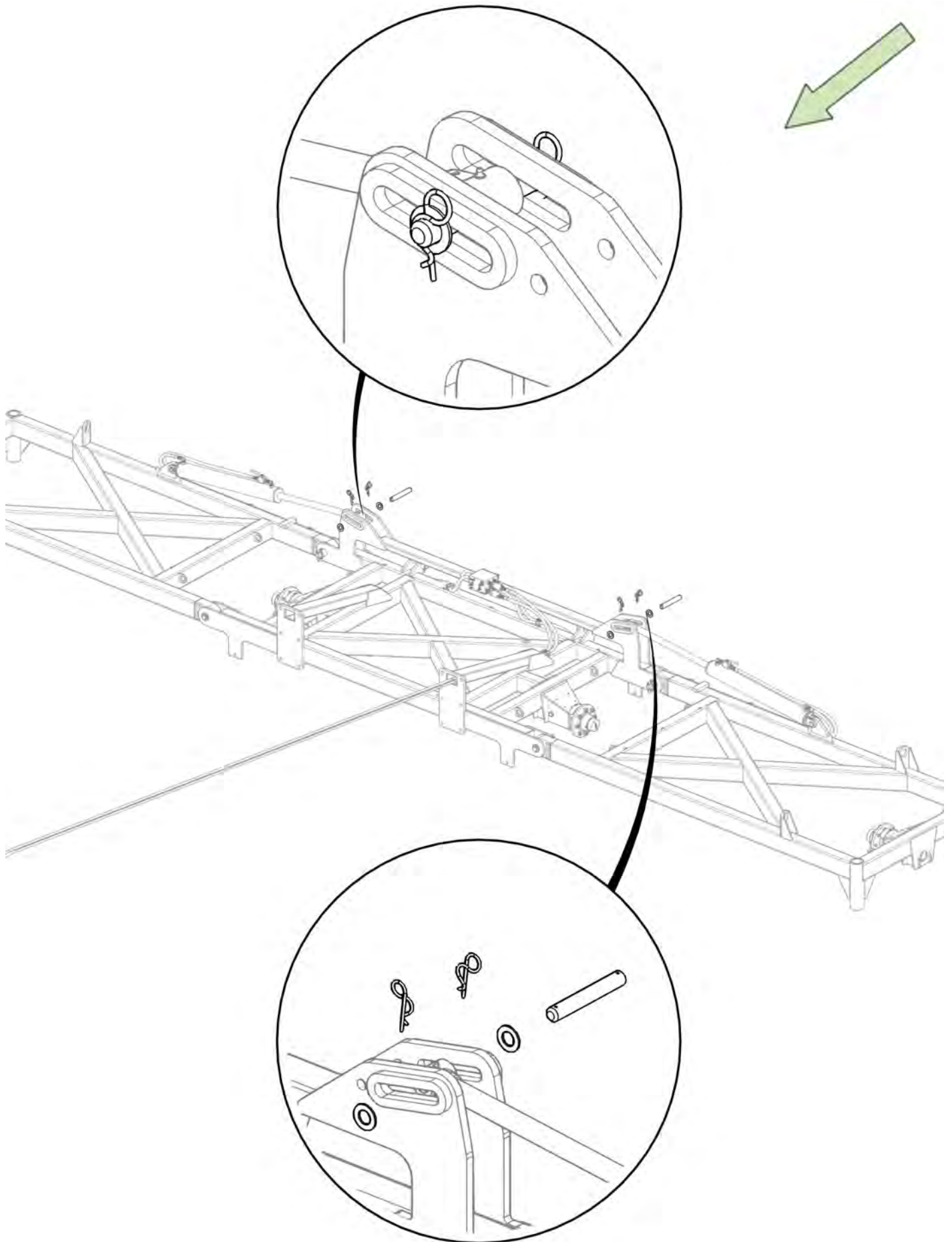



| Item No. | Description                | Number     | Qty |
|----------|----------------------------|------------|-----|
| 1        | 30' Main Pull              | 0830-02-2  | 1   |
| 2        | Nyloc Nut M24              | 0221-NYL24 | 12  |
| 3        | M24 x 80 grade 8.8 zp Bolt | 0211-2480  | 12  |
| 4        | Washer Flat M24            | 0231-F24   | 24  |

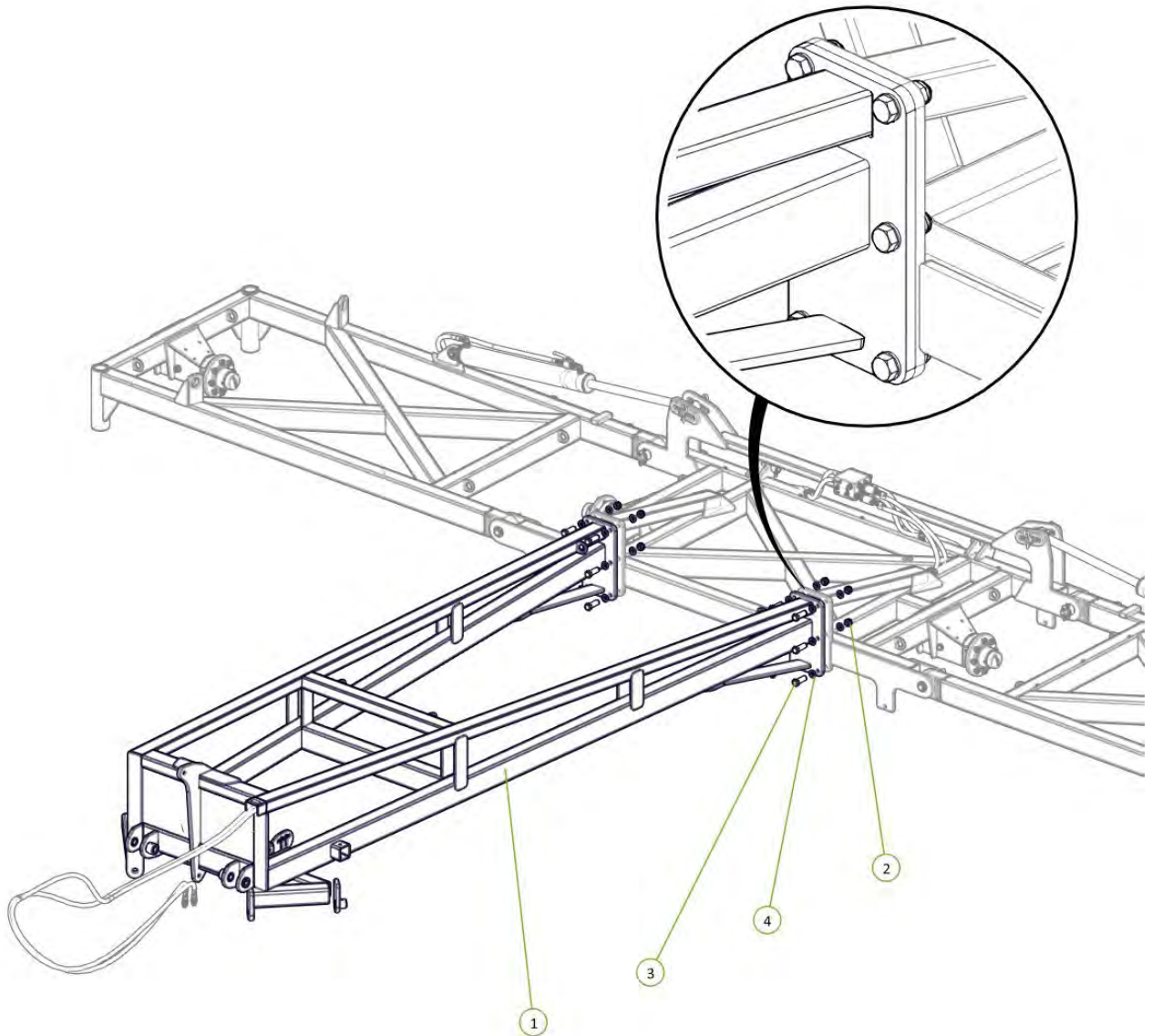

| Item No. | Description                                      | Number               | Qty |
|----------|--|----------------------|-----|
| 1        | 400/55-22.5 Tyre on 8 on 8" PCD Rim (Left Hand)  | 0751-400-55-22.5TR-L | 2   |
| 2        | 400/55-22.5 Tyre on 8 on 8" PCD Rim (Right Hand) | 0751-400-55-22.5TR-R | 2   |

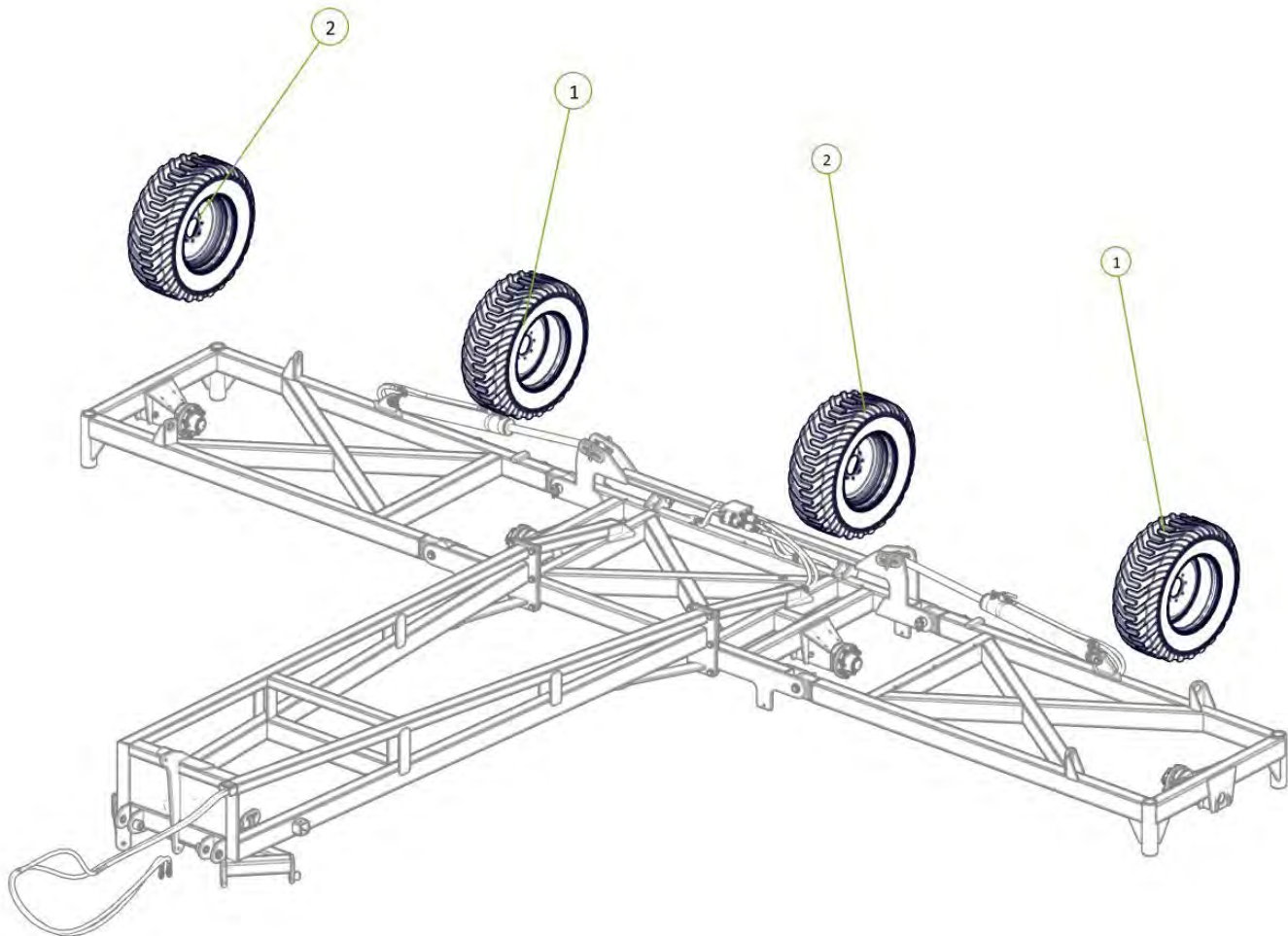
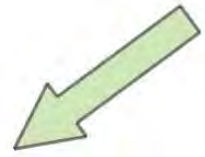

Note tread direction

Torque wheel nuts to 100ft-lb / 140Nm

| Item No. | Description                    | Number        | Qty |
|----------|--------------------------------|---------------|-----|
| 1        | Tapered T-Bar Drawbar          | 1510-08-2     | 1   |
| 2        | Drawbar Pivot Bush             | 0801-B423838  | 4   |
| 3        | Walking Axle Linkage Pivot Pin | 1601-P38-220  | 2   |
| 4        | Cotter Pin M13 x 63            | 0261-PINC1363 | 2   |
| 5        | Nyloc Nut M12                  | 0221-NYL12    | 2   |
| 6        | M12 x 90 Class 8,8 7P Bolt     | 0211-1290     | 2   |

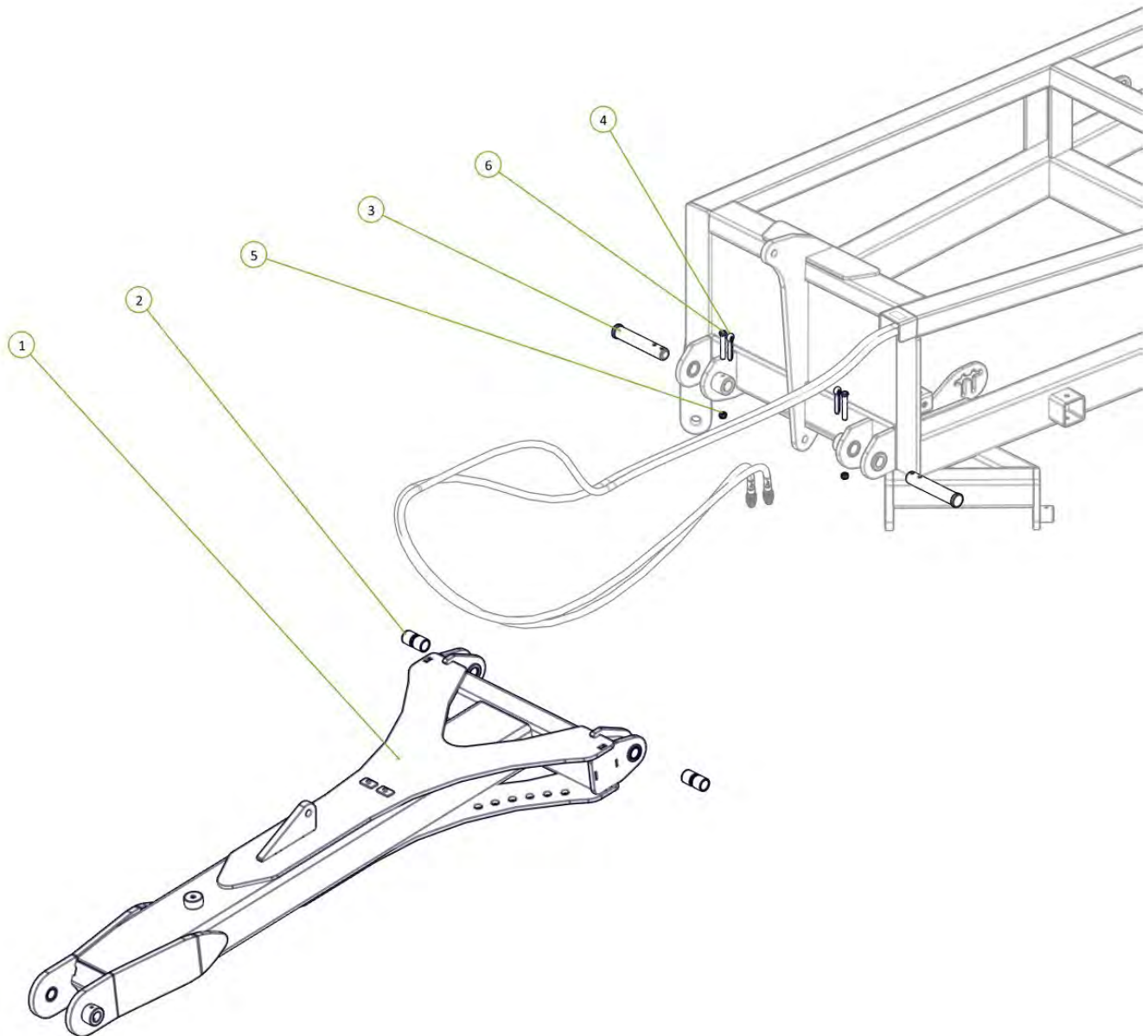



| Item No. | Description                                   | Number              | Qty |
|----------|---|---------------------|-----|
| 1        | Bull Pull Swivel Hitch CAT 4 wt 1-1/2' Insert | 0801-BPF-CAT-4JDF-2 | 1   |
| 2        | Tow Hitch Pivot Pin                           | 0801-10-14          | 1   |
| 3        | Tow Hitch For Bull Pull Swivel Hitch          | 0810-09-BP          | 1   |
| 4        | 1" x 5-1/2" UNF Grade 8 ZP Bolt               | 0213-1 51-2         | 3   |
| 5        | M12 x 90 Class 8.8 ZP Bolt                    | 0211-1290           | 2   |
| 6        | Nyloc Nut M12                                 | 0221-NYL12          | 2   |
| 7        | 35 ID x 50mm DX Bush                          | 0113-MB3550DX       | 2   |
| 8        | Grease Nipple 1/4" UNF 45°                    | 0181-GN1/445        | 2   |
| 9        | Nyloc Nut 1" UNF                              | 0223-NYL1           | 3   |

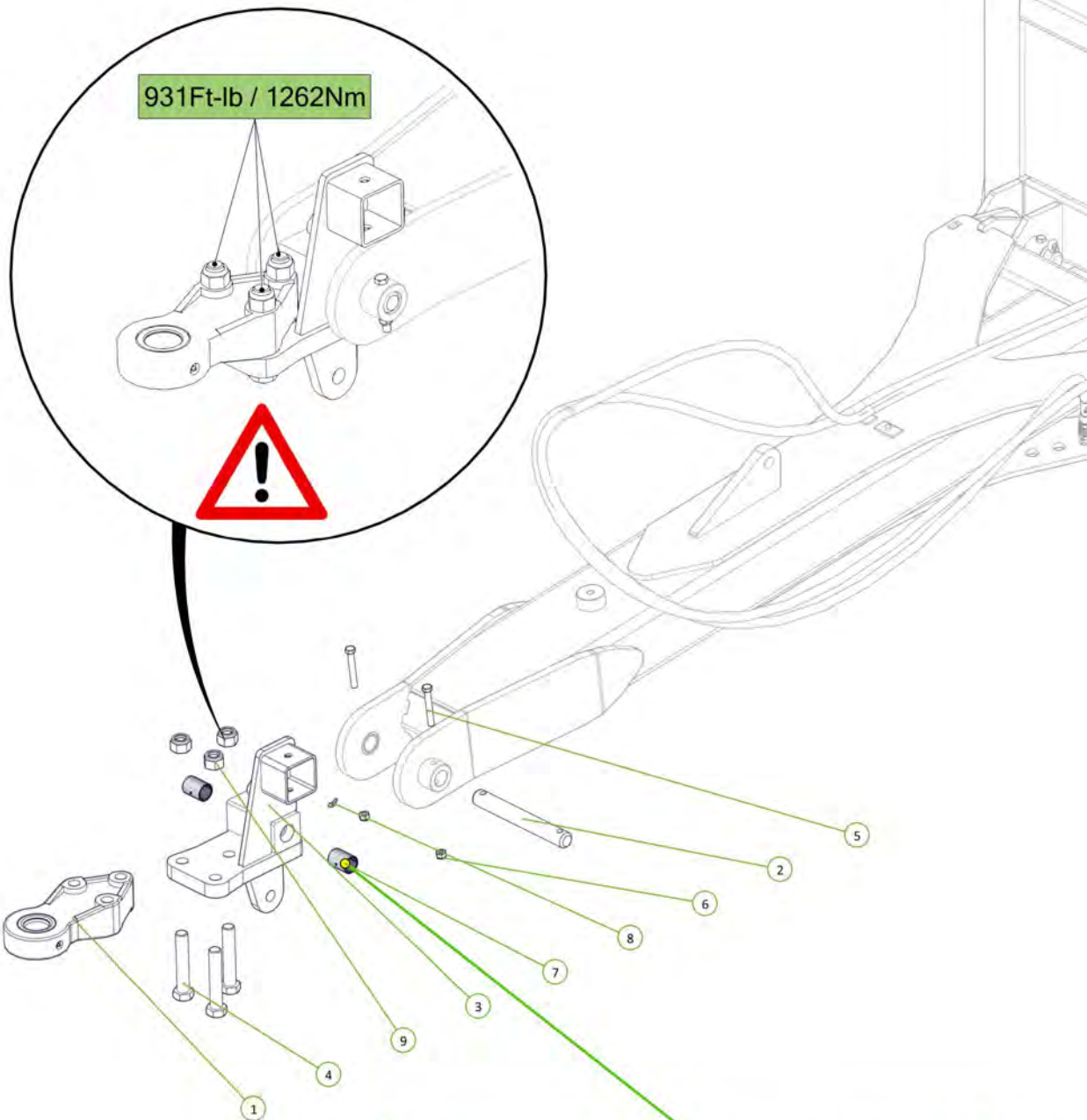
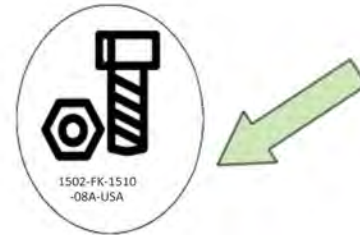

Make sure to align bush hole with grease nipple hole in tow hitch

| Item No. | Description            | Number        | Qty |
|----------|------------------------|---------------|-----|
| 1        | Parallel Arm           | 0810-58       | 1   |
| 2        | Clevis Pin 25mm x 75mm | 0801-KE0307-1 | 2   |
| 3        | Washer Flat M24        | 0231-F24      | 2   |
| 4        | Cotter Pin M5 x 50     | 0261-PINC550  | 2   |

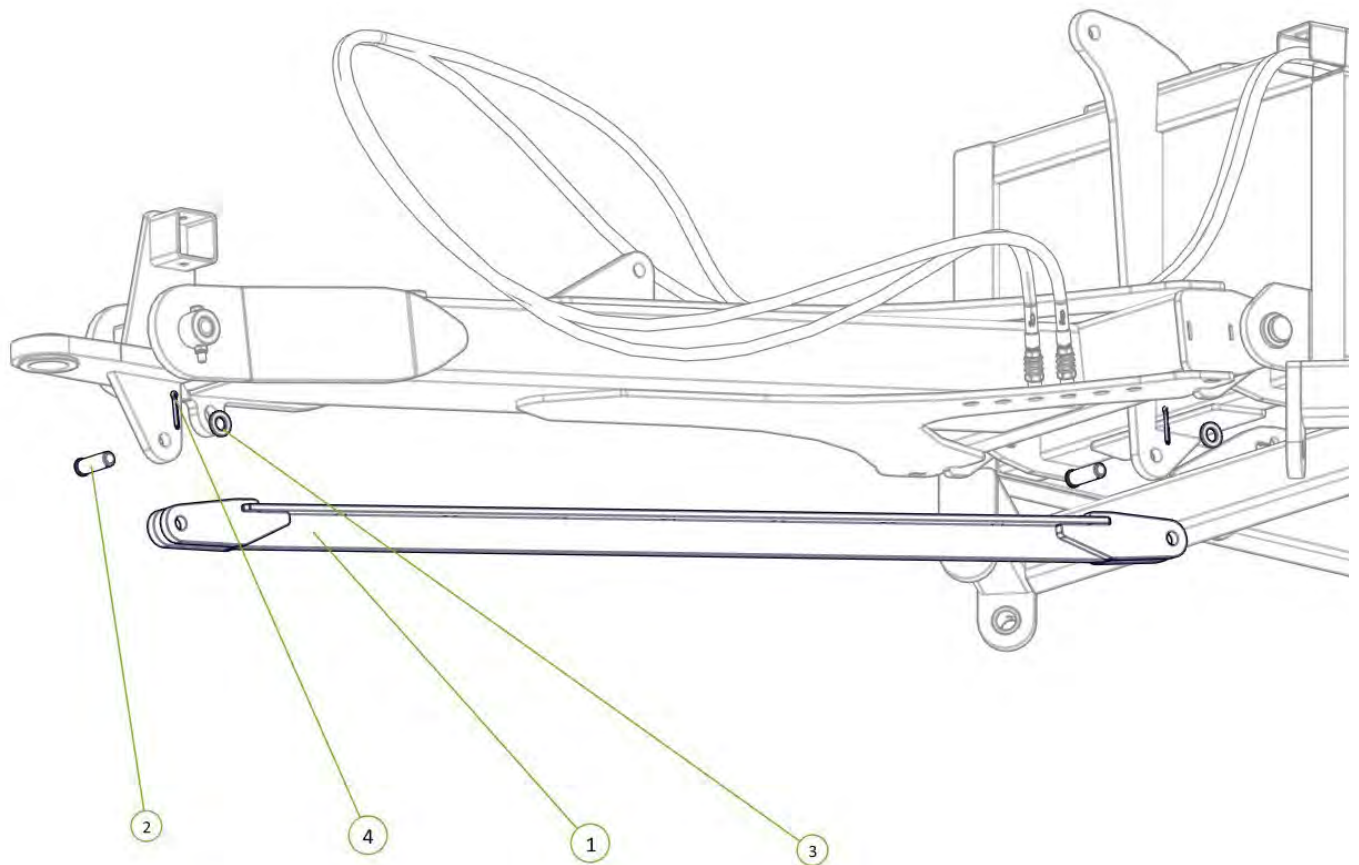

| Item No. | Description   | Number      | Qty |
|----------|---|-------------|-----|
| 1        | 3" Bore x 12" Stroke 1.5" Rod Extended Hydraulic Cylinder | 0311-312EXT | 1   |

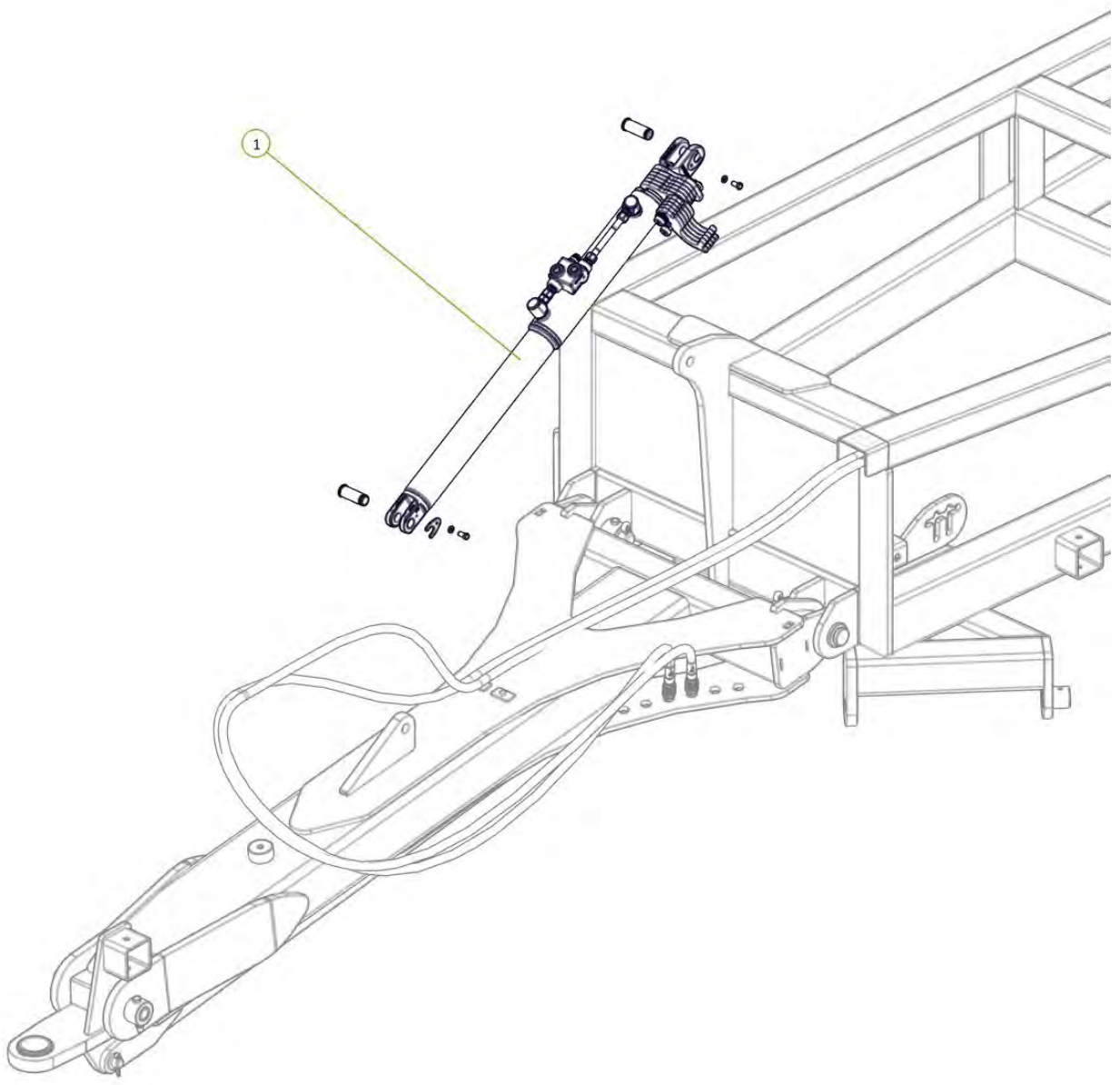
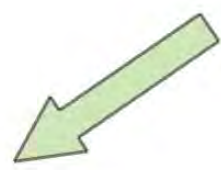

| Item No. | Description     | Number      | Qty |
|----------|-----------------|-------------|-----|
| 1        | Heavy Duty Jack | 0801-SAK45B | 1   |
| 2        | Jack Pin        | 0801-B3077  | 1   |

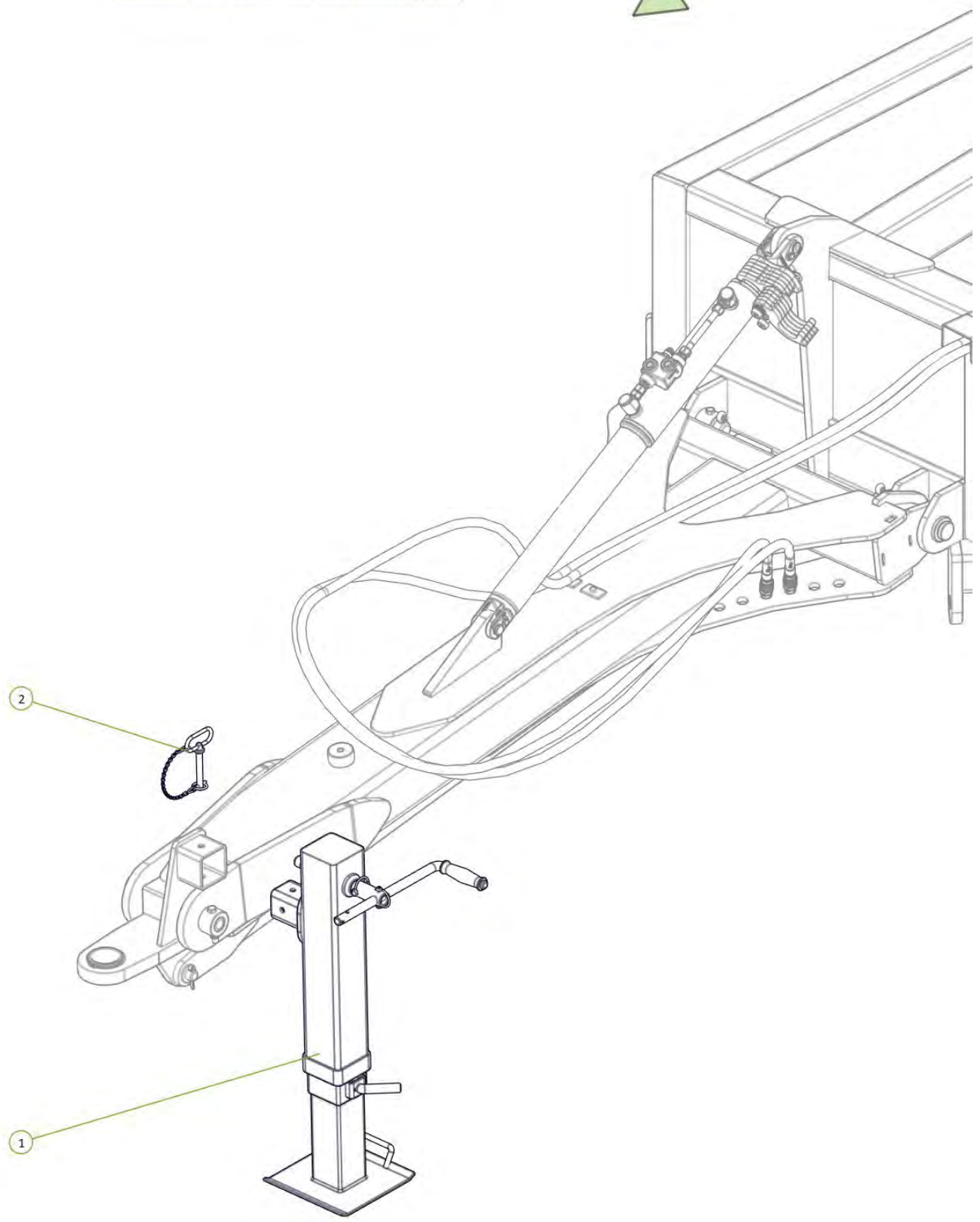
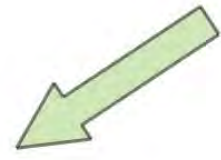



| Item No. | Description                | Number           | Qty |
|----------|----------------------------|------------------|-----|
| 1        | Hose Post Spring           | 1601-CDB-00-0012 | 1   |
| 2        | Washer Flat M16            | 0231-F16         | 1   |
| 3        | Washer Spring M16          | 0231-S16         | 1   |
| 4        | M16 x 35 grade 8.8 zp Bolt | 0211-1635        | 1   |

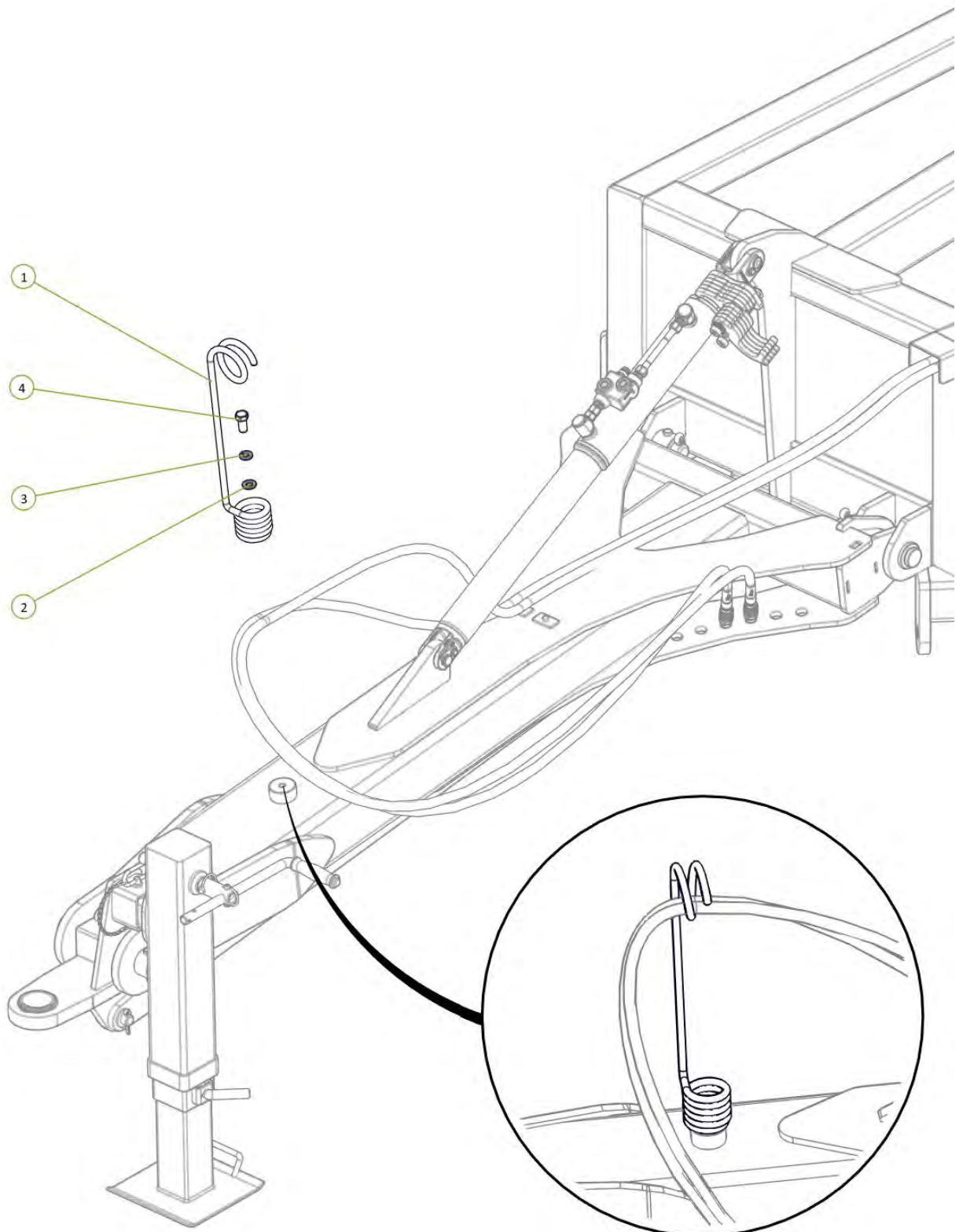



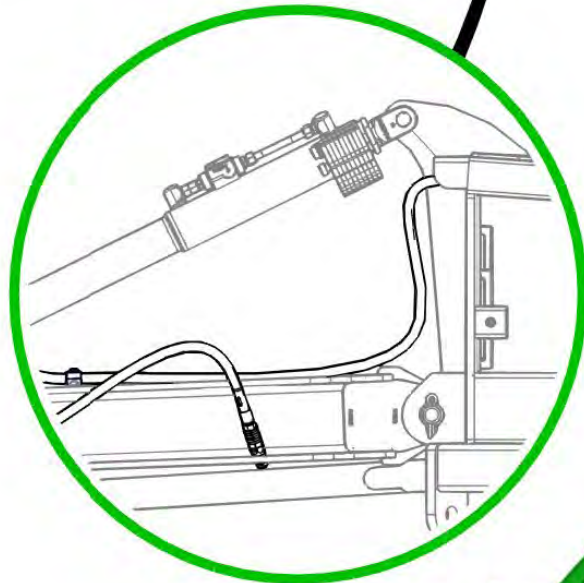
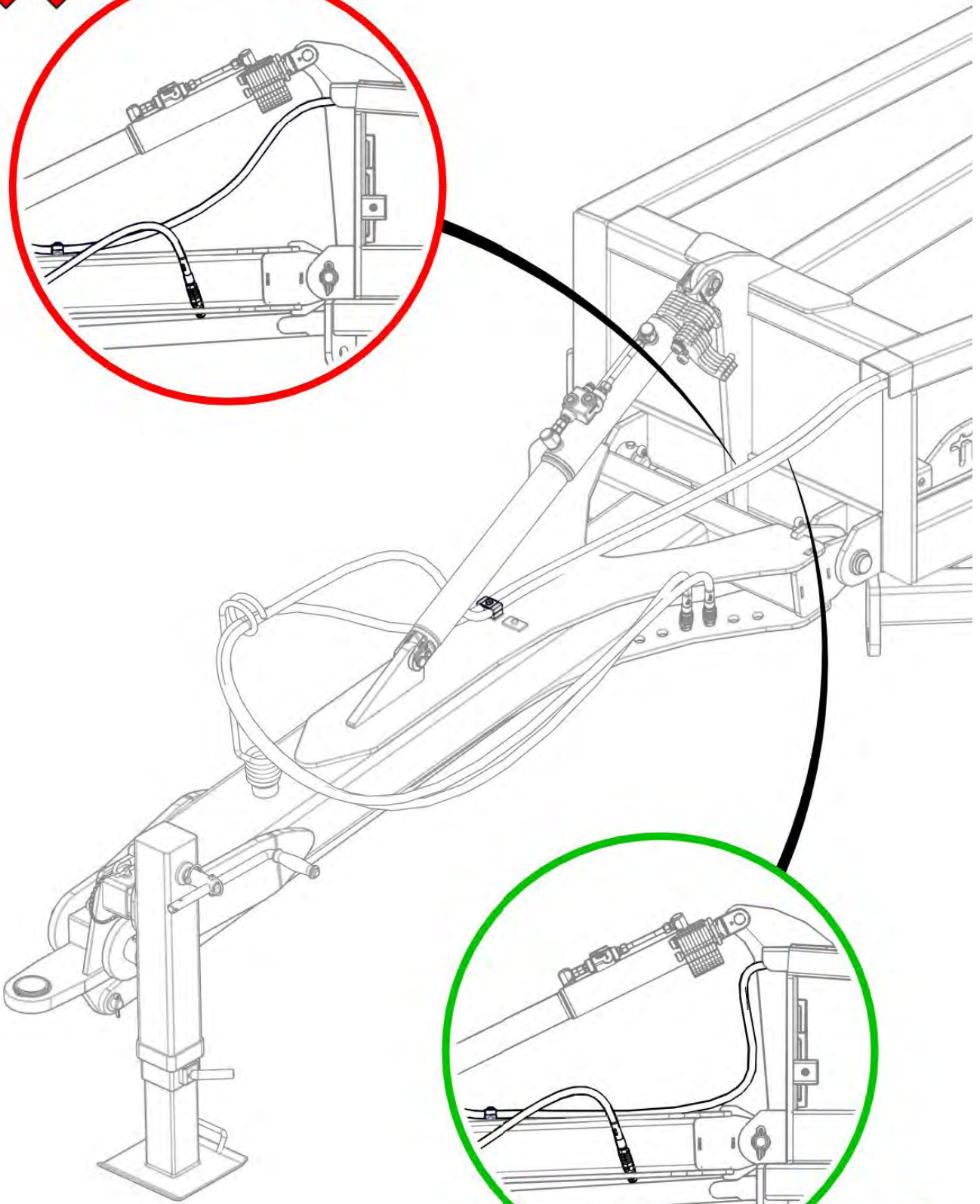
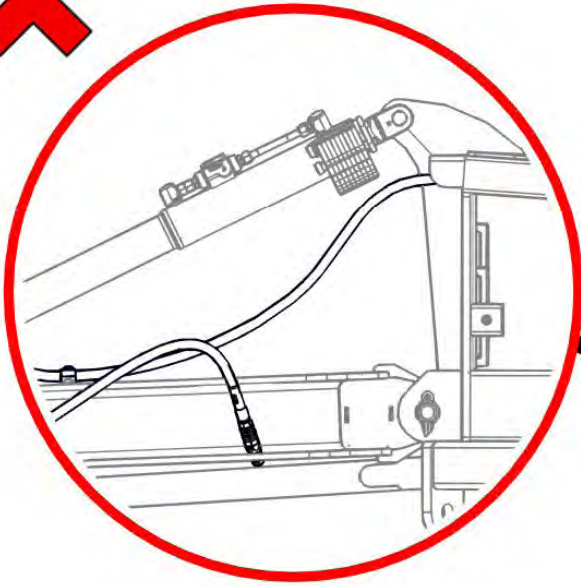

| Item No. | Description   | Number         | Qty |
|----------|---|----------------|-----|
| 1        | 1/2" BSPP Encapt Male 3/4" JIC Female Swive Adaptor | 0323-S71-0812  | 2   |
| 2        | In Line Hydraulic Oil Filter                        | 0343-924001261 | 2   |
| 3        | 1/2" BSPP Encapt Male 3/4" JIC Male Adaptor         | 0323-S74-0812  | 2   |

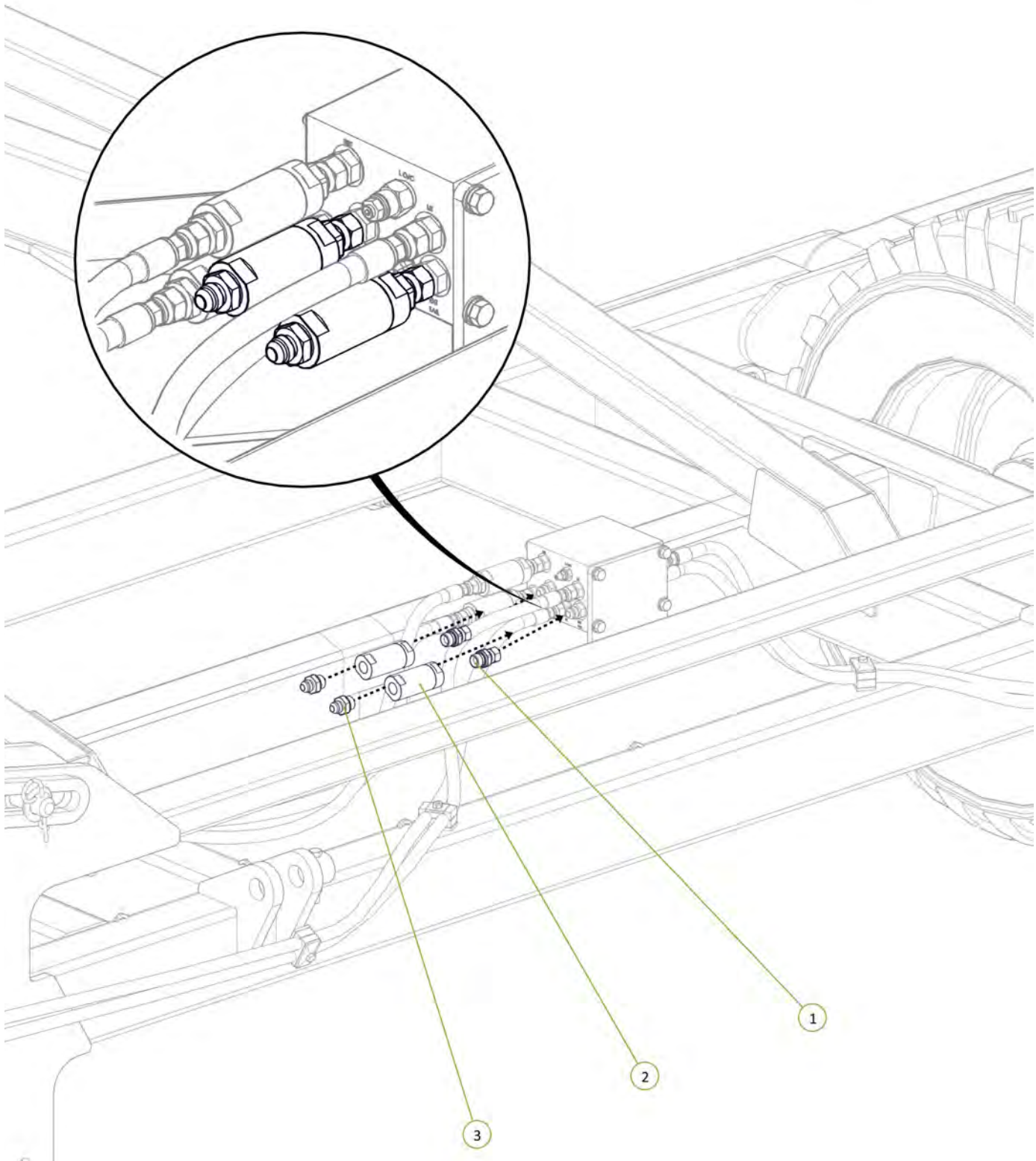
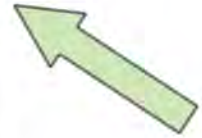



| Item No. | Description  | Number               | Qty |
|----------|--|----------------------|-----|
| 1        | Tractor to Sequence Valve TAIL EXT Port fitted with Yellow Extend Decal  | PH30S-01-YE-TAIL EXT | 1   |
| 2        | Tractor to Sequence Valve TAIL RET Port fitted with Yellow Retract Decal | PH30S-01-YR-TAIL RCT | 1   |

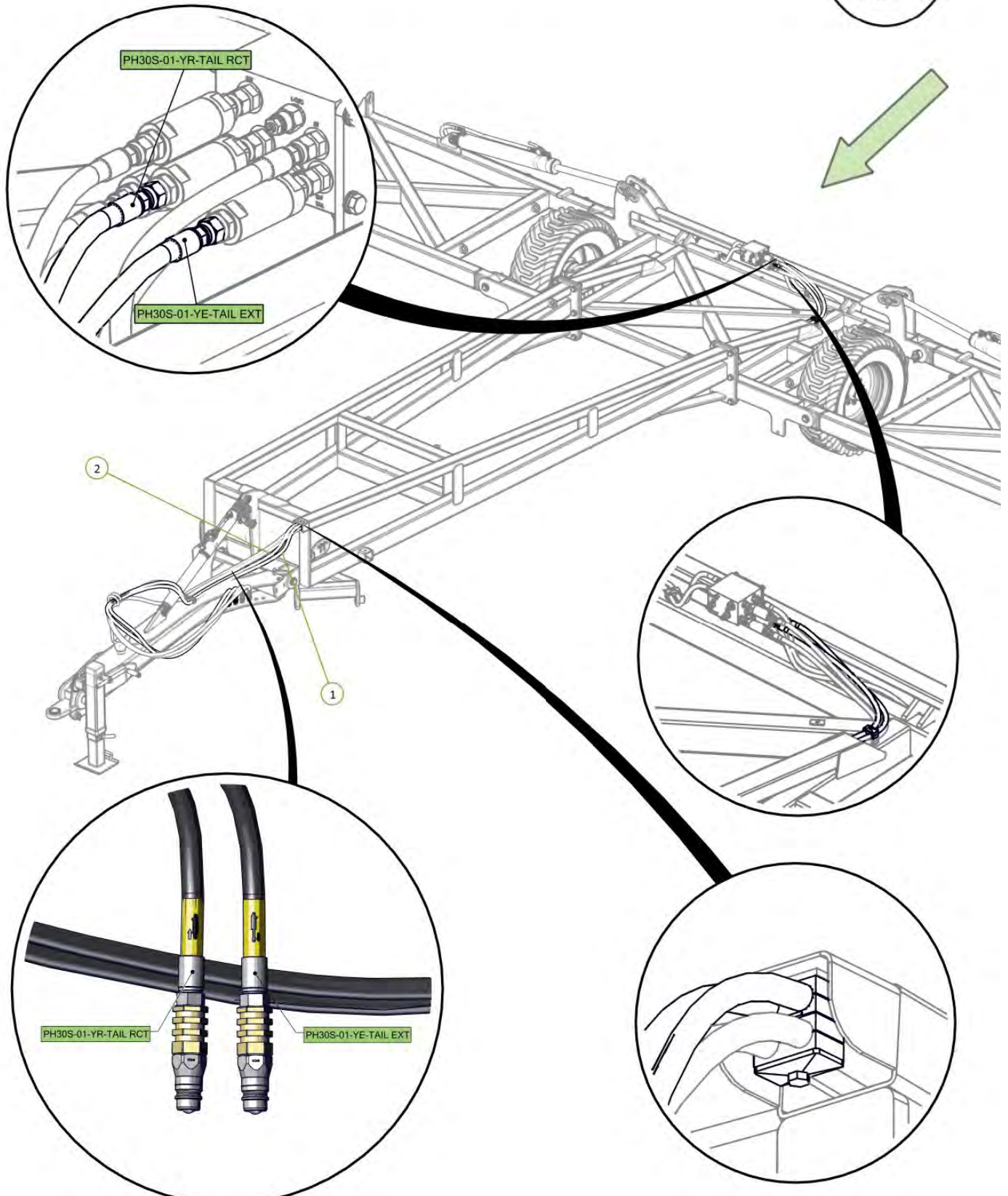

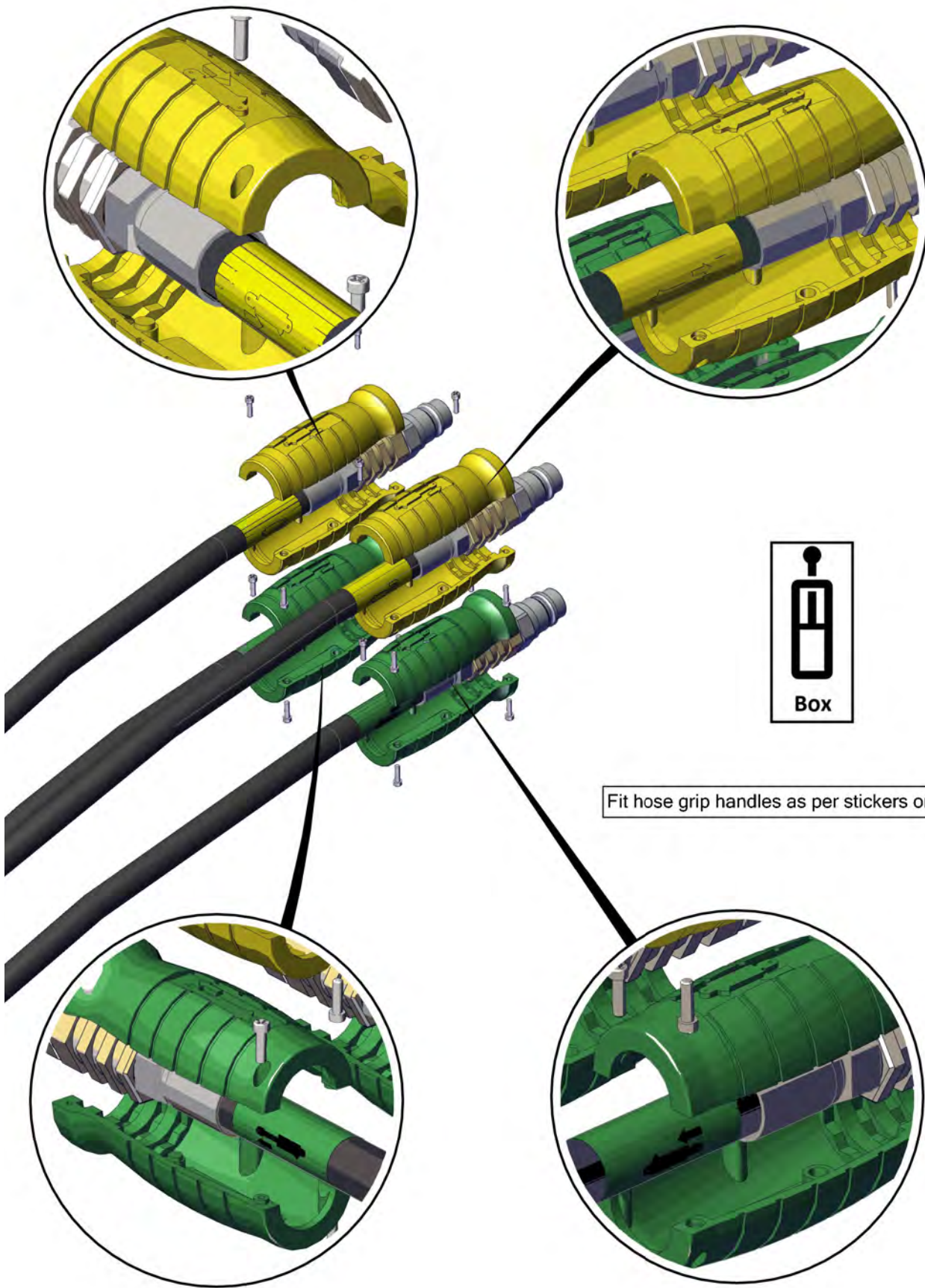



| Item No. | Description                                 | Number        | Qty |
|----------|---|---------------|-----|
| 1        | 3/4" JIC Male 3/4" UN O Ring Male 90° Elbow | 0323-S91-1212 | 2   |

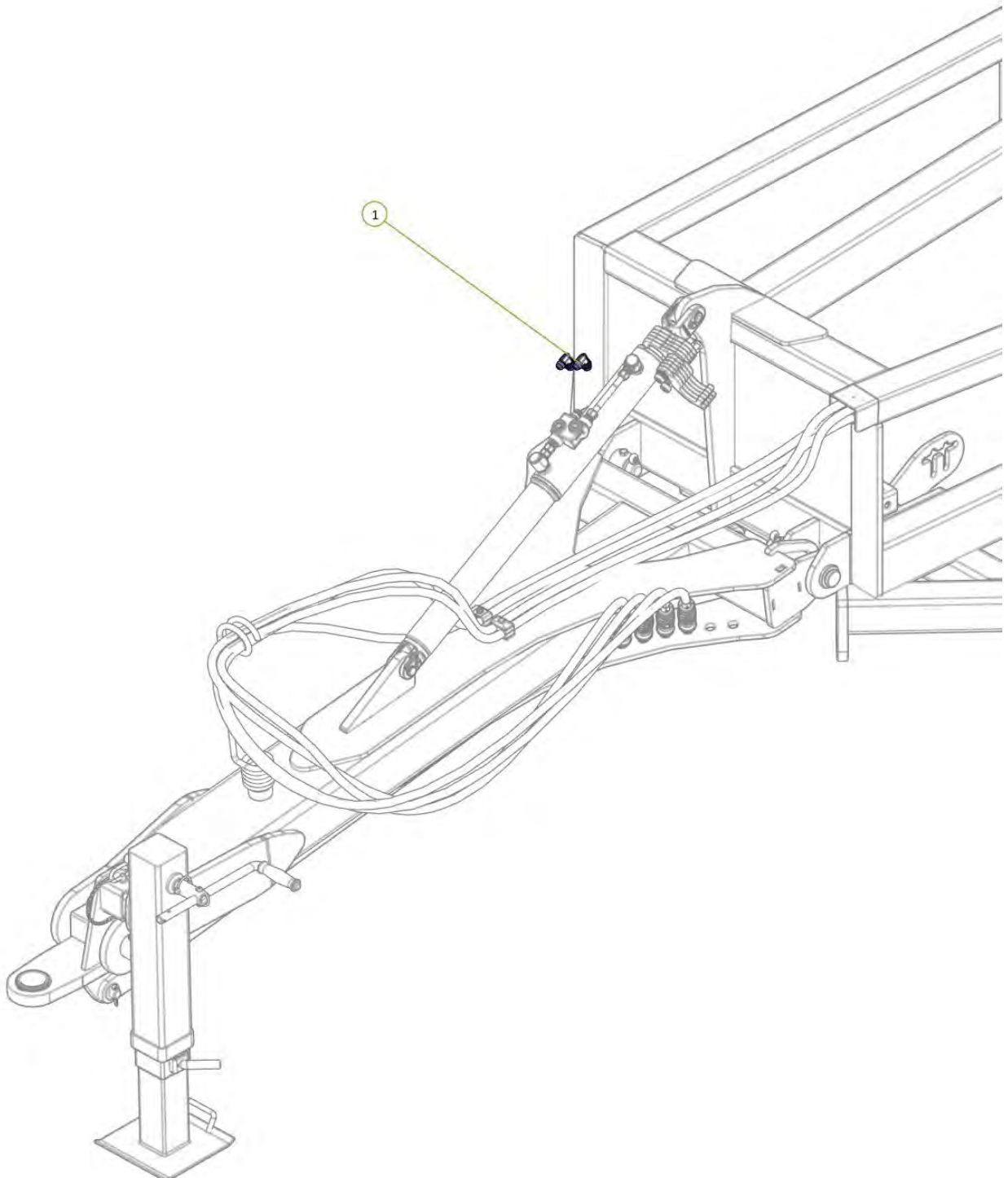
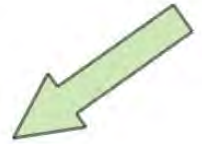



| Item No. | Description   | Number          | Qty |
|----------|---|-----------------|-----|
| 1        | Tractor to Front Lift Cylinder Extend Port fitted with Blue Extend Grip   | PH30S-02-BE-EXT | 1   |
| 2        | Tractor to Front Lift Cylinder Retract Port fitted with Blue Retract Grip | PH30S-02-BR-RCT | 1   |

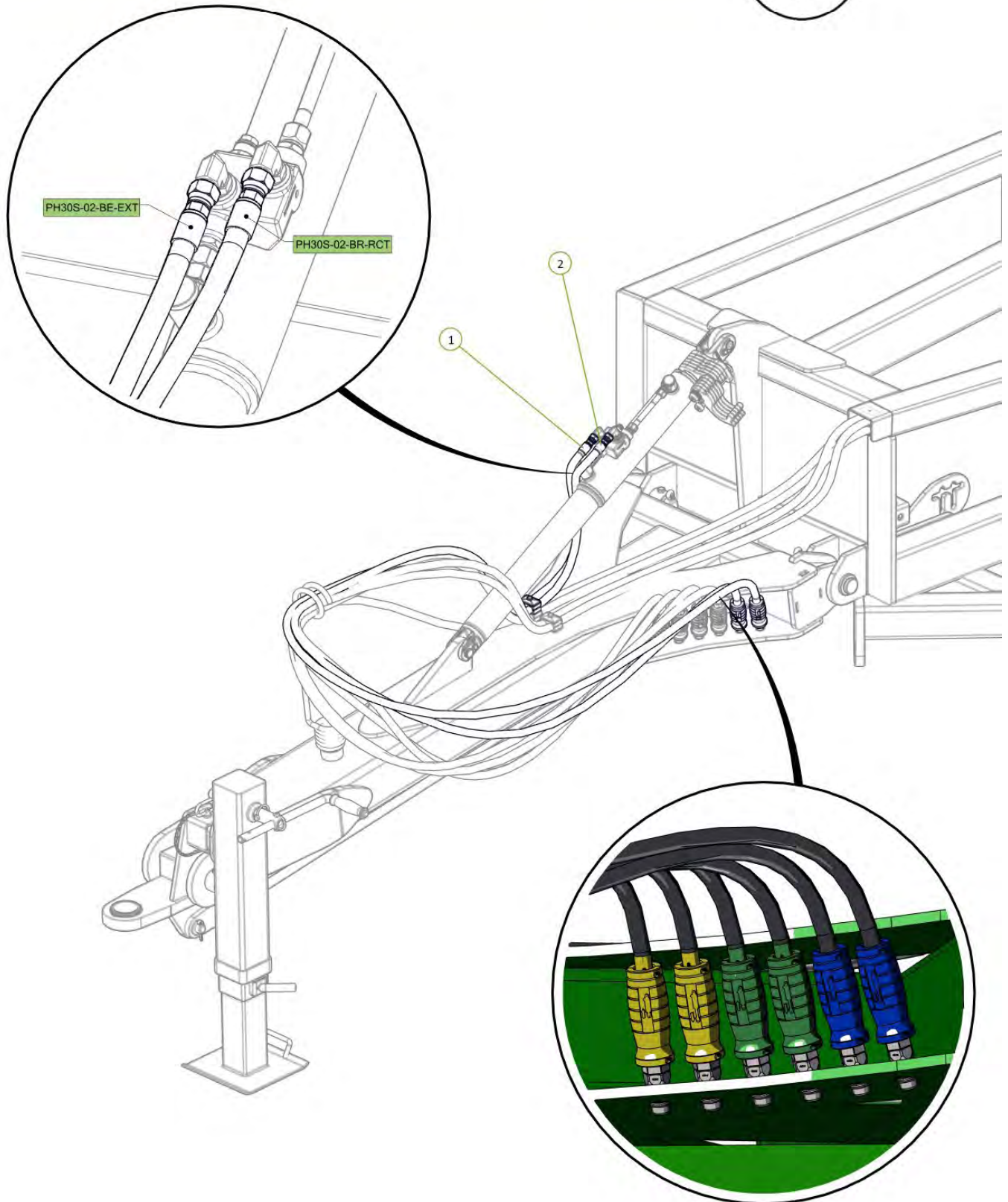

**IMPORTANT:** Refer to page 7

| Item No. | Description                | Number         | Qty |
|----------|----------------------------|----------------|-----|
| 1        | 30' Rear A-Frame           | 0830-03-2      | 1   |
| 2        | Tail Frame Pivot pin       | 0801-10-08-175 | 2   |
| 3        | Nyloc Nut M12              | 0221-NYL12     | 2   |
| 4        | M12 x 80 Class 8.8 ZP Bolt | 0211-1280      | 2   |
| 5        | Cotter Pin M13 x 63        | 0261-PINC1363  | 2   |

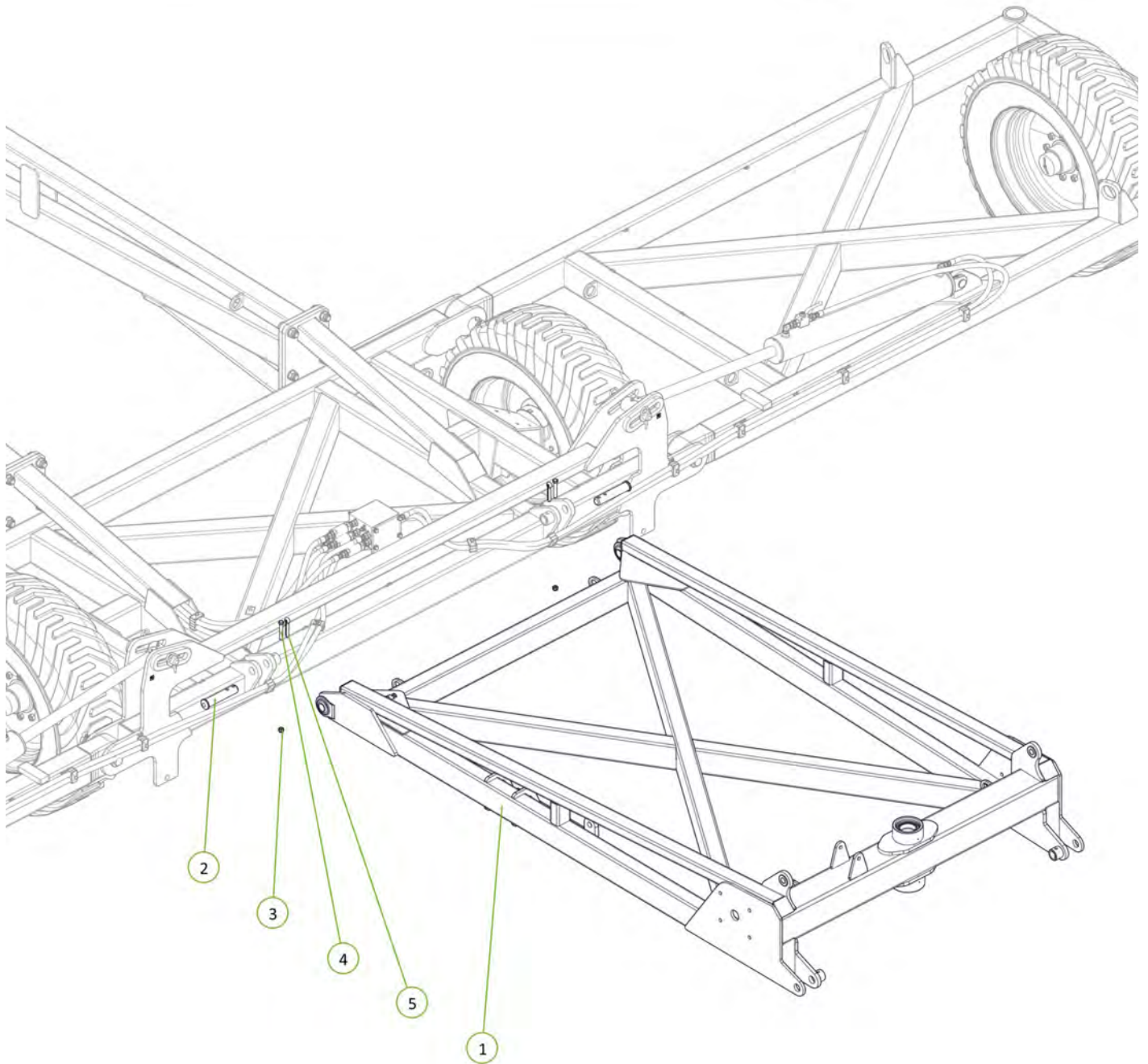



| Item No. | Description                  | Number             | Qty |
|----------|------------------------------|--------------------|-----|
| 1        | 70mm Jockey Wheel (Sleeved)  | 1610-12-70         | 1   |
| 2        | Plain Spherical Bearing 70mm | 0113-GE70DO-2RS    | 2   |
| 3        | Circlip Internal 105mm       | 0171-J105          | 2   |
| 4        | TC Seal 90mm x 125mm x 13mm  | 0121-TC12681       | 1   |
| 5        | Circlip External 70mm        | 0172-D1400-0700APP | 1   |
| 6        | Grease Nipple 1/4" UNF 45°   | 0181-GN1/445       | 2   |

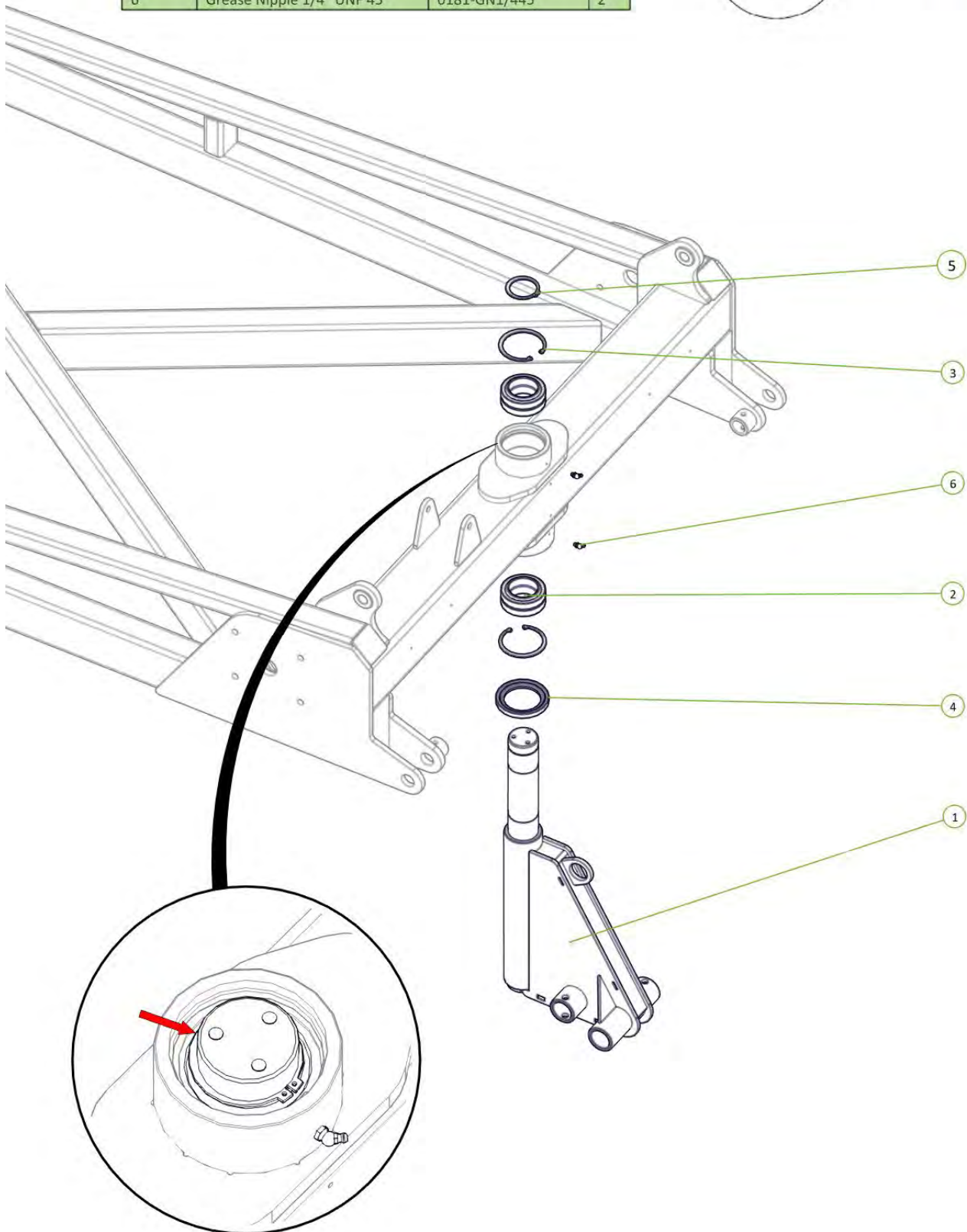

| Item No. | Description          | Number       | Qty |
|----------|----------------------|--------------|-----|
| 1        | Brake Disc           | 1600-405     | 1   |
| 2        | M12 x 24 Wheel Bolt  | 0216-WB1224  | 3   |
| 3        | Seal 70 x 100 x 10mm | 0121-TC12654 | 1   |

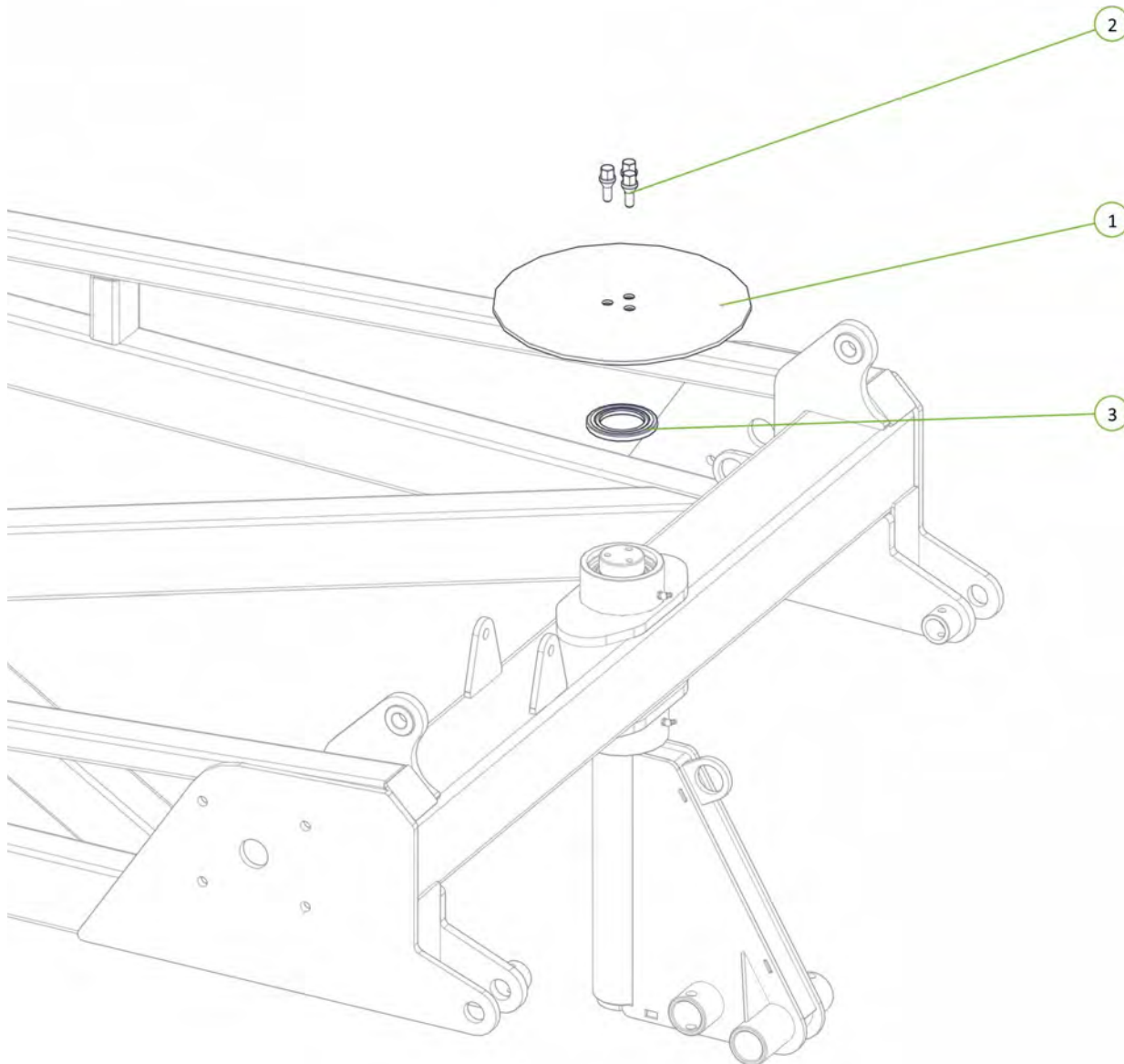

bolts torqued to 65fl-lb / 88Nm



| Item No. | Description                 | Number       | Qty |
|----------|-----------------------------|--------------|-----|
| 1        | Jockey Wheel Brake Caliper  | 0810-12CALA  | 1   |
| 2        | Brake Compression Spring    | 0801-KE009   | 1   |
| 3        | Washer Square M16 x 50 x 5  | 0231-SQ16505 | 1   |
| 4        | Brake Spring Indicator      | 0800-772     | 1   |
| 5        | M16 x 150 Class 8.8 ZP Bolt | 0211-16150   | 1   |
| 6        | M16 x 160 Class 8.8 ZP Bolt | 0211-16160   | 1   |
| 7        | Washer Flat M16             | 0231-F16     | 2   |
| 8        | Nyloc Nut M16               | 0221-NYL16   | 1   |

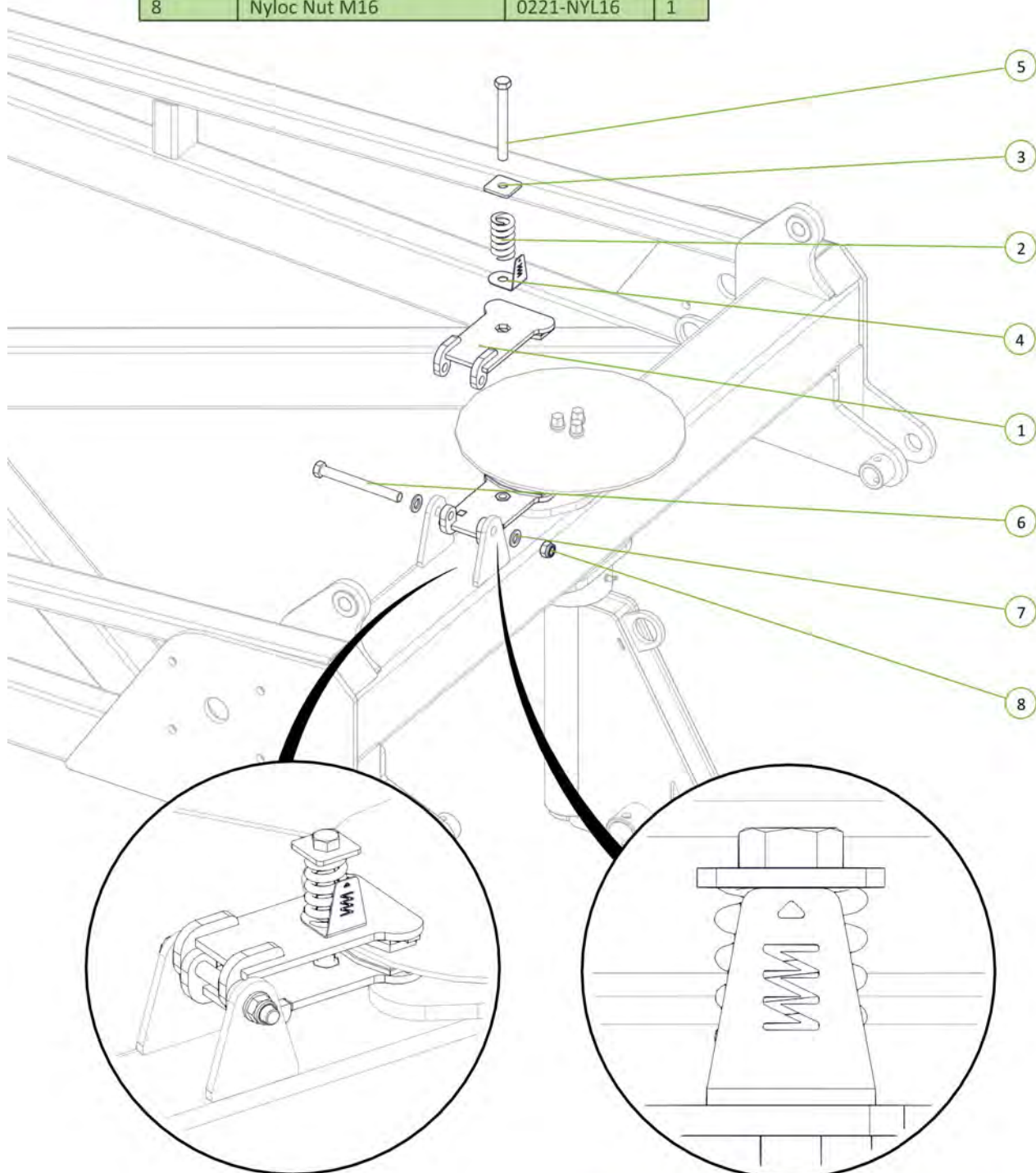

Compress spring to top of Indicator as shown



| Item No. | Description   | Number         | Qty |
|----------|---|----------------|-----|
| 1        | Axle 2"R 3T 6 on 6"PCD 330 OHF Complete Assembly Inc GS | 0733-LG8880093 | 2   |
| 2        | M16 x 90 grade 8.8 zp Bolt                              | 0211-16        | 2   |
| 3        | Nyloc Nut M16   | 0221-NYL16     | 2   |

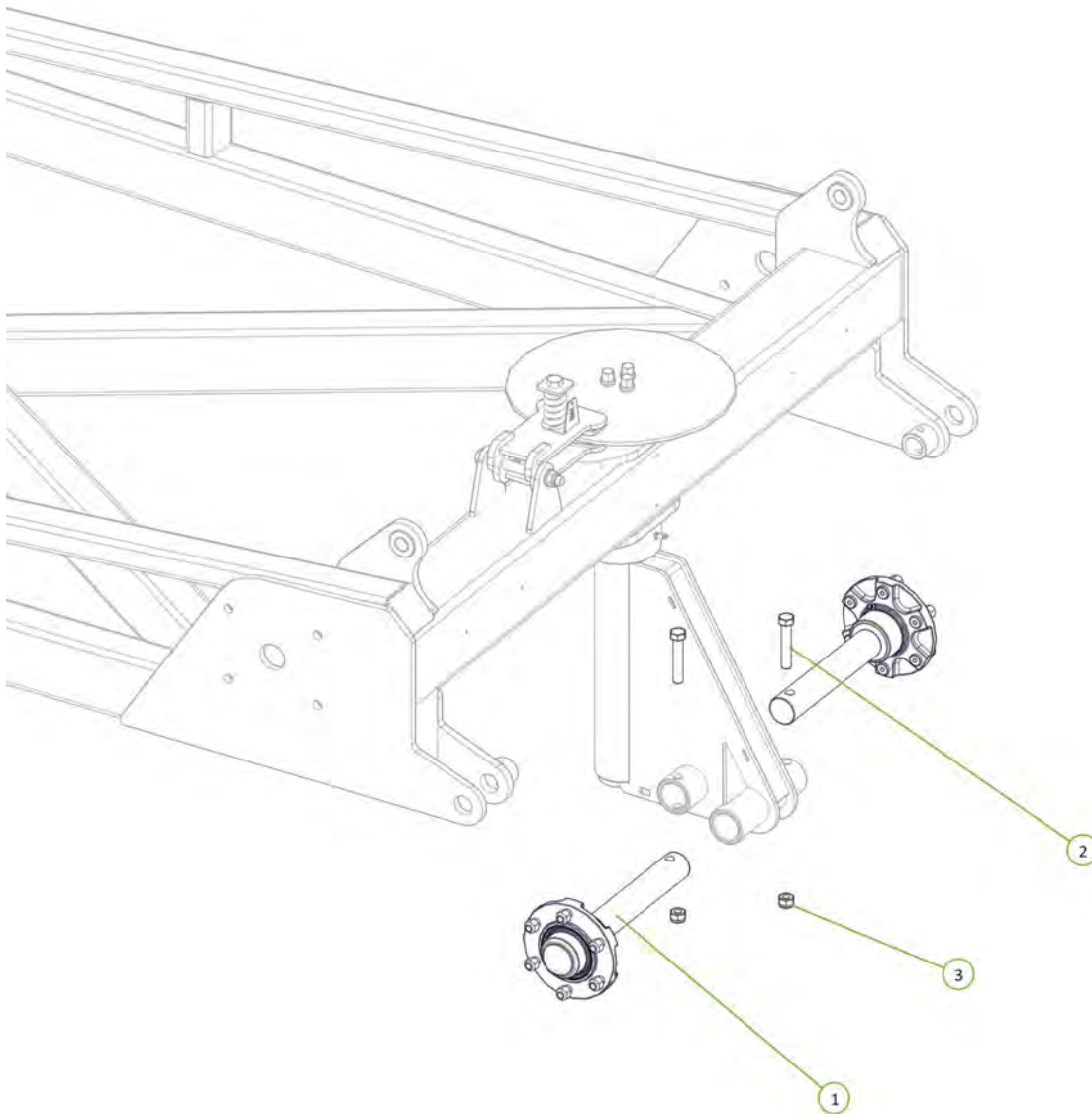
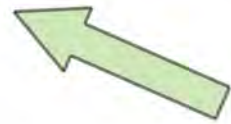

## NOTE

The hub (0733-SH27596880) showed on item one is interchangeable. (Refer to page 8 for more information).

| Item No. | Description                       | Number     | Qty |
|----------|-----------------------------------|------------|-----|
| 1        | 11L15 F3 Tyre on 6 on 6" Stud Rim | 0751-11L15 | 2   |

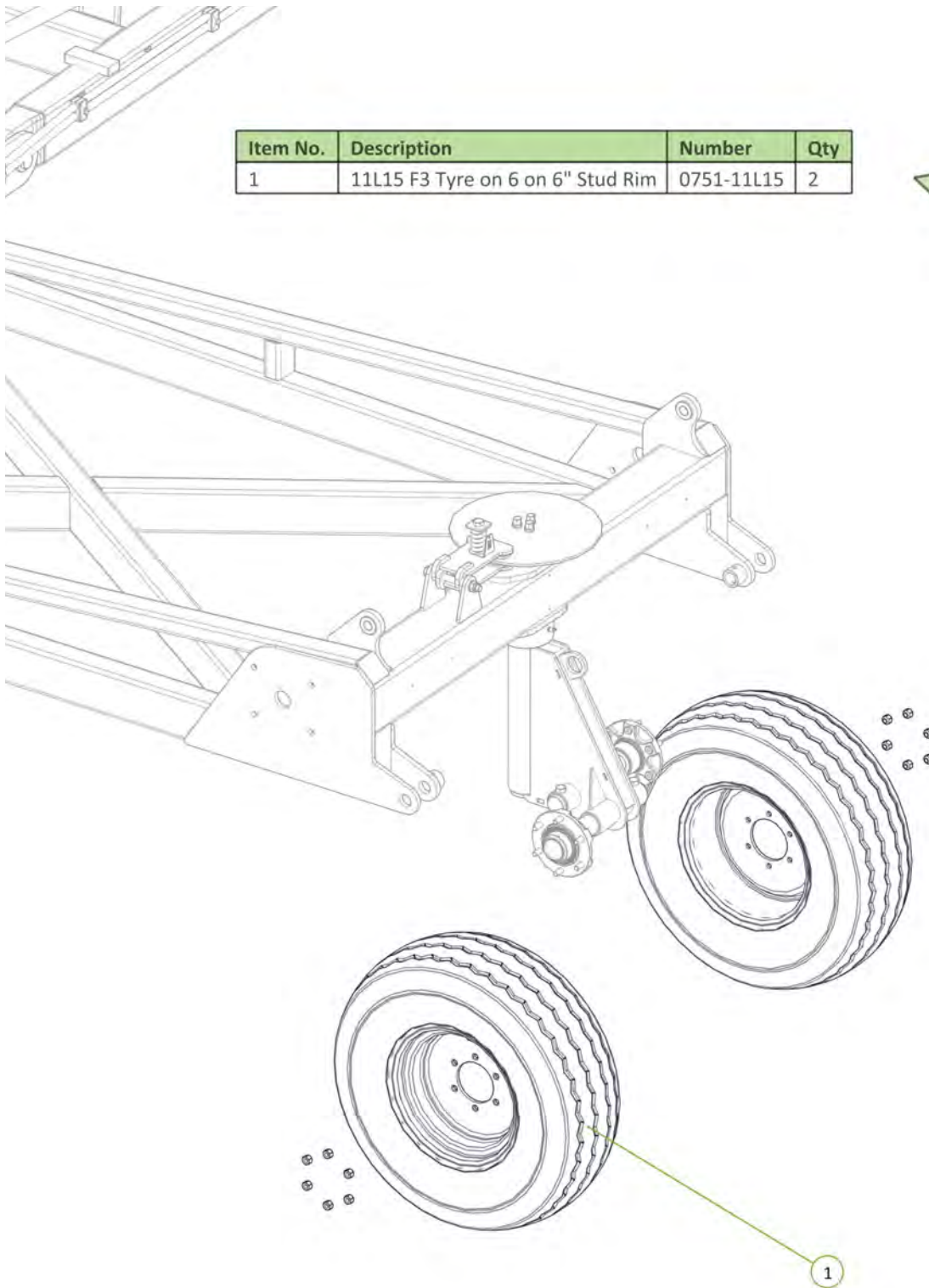

Torque wheel nuts to 90ft-lb / 125Nm

| Item No. | Description                | Number         | Qty |
|----------|----------------------------|----------------|-----|
| 1        | Extended Tip Rear Tail     | 0810-10E       | 1   |
| 2        | Tail Frame Pivot pin       | 0801-10-08-175 | 2   |
| 3        | M12 x 80 Class 8.8 ZP Bolt | 0211-1280      | 2   |
| 4        | Nyloc Nut M12              | 0221-NYL12     | 2   |
| 5        | Cotter Pin M13 x 63        | 0261-PINC1363  | 2   |

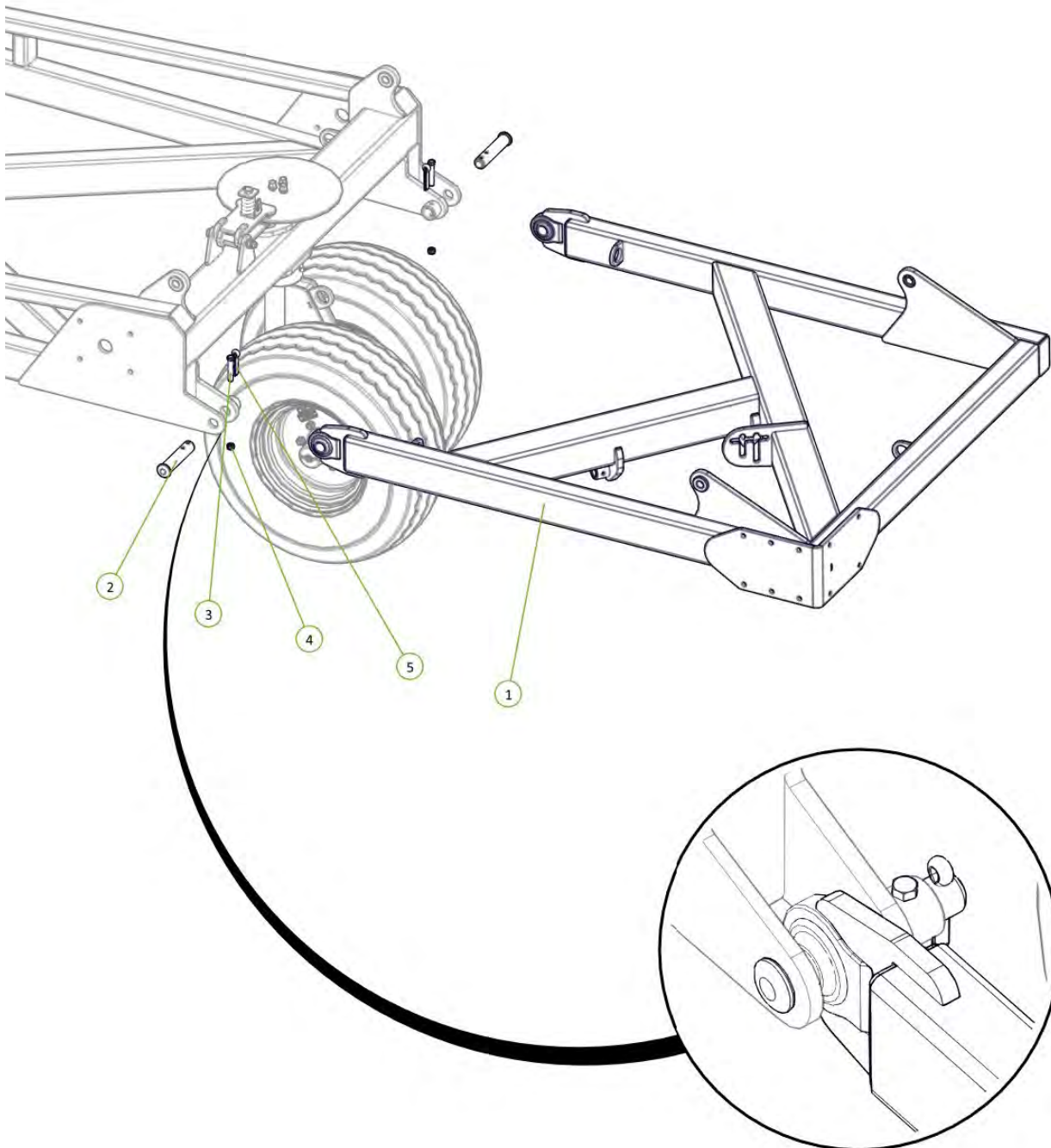

| Item No. | Description   | Number      | Qty |
|----------|---|-------------|-----|
| 1        | 3.5" Bore x 24" Stroke 1.75" Rod Side Port Cylinder | 0311-3524SP | 2   |

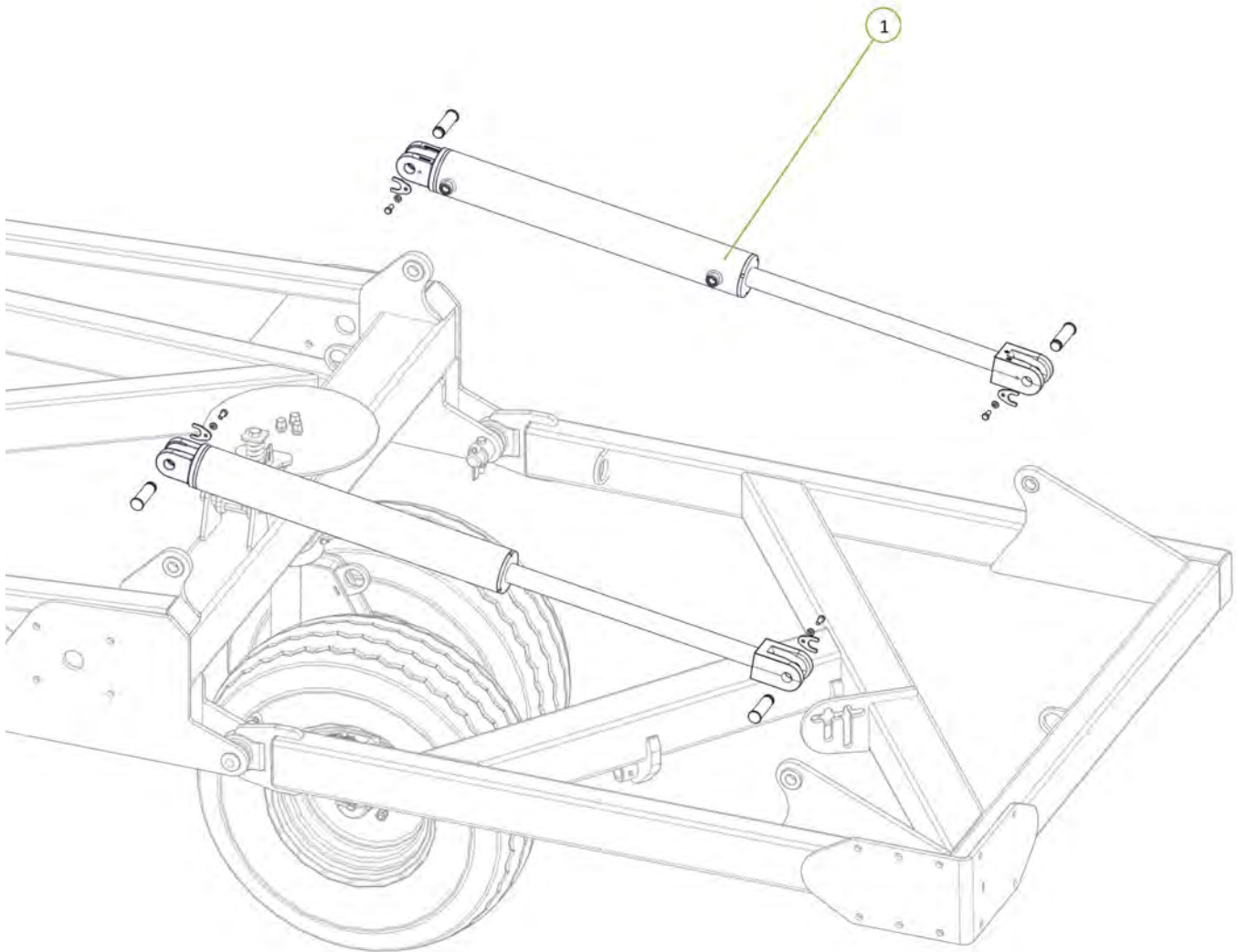



| Item No. | Description                                 | Number        | Qty |
|----------|---|---------------|-----|
| 1        | 3/4" JIC Male 3/4" UN O Ring Male 90° Elbow | 0323-S91-1212 | 4   |

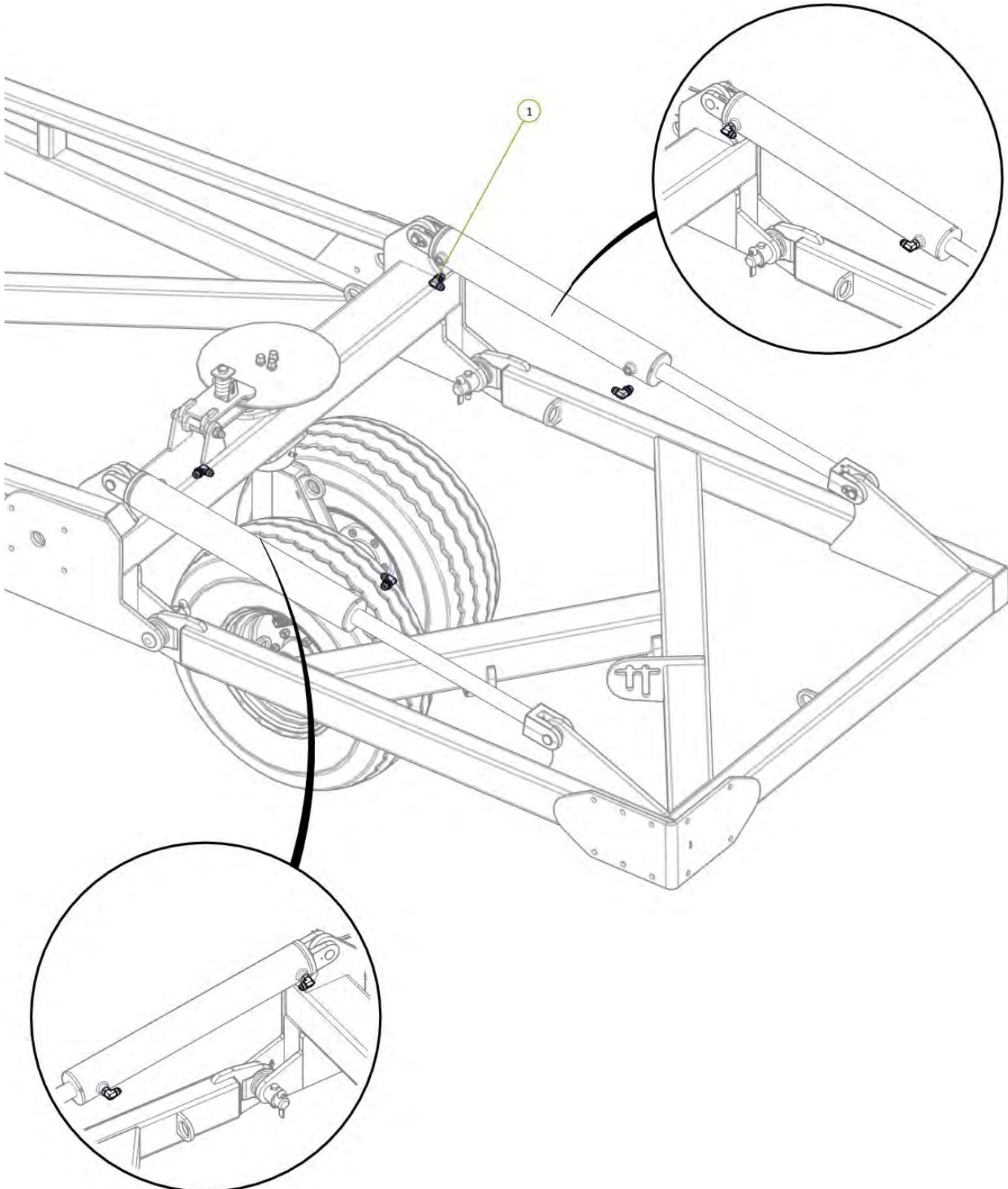

| Item No. | Description   | Number          | Qty |
|----------|---|-----------------|-----|
| 1        | Valve TE Port to Tail Extend Tee                      | PH30S-05        | 1   |
| 2        | Valve TR Port to Tail Retract Tee                     | PH30S-06        | 1   |
| 3        | 3/4" JIC Male Tee 3/4" JIC Male Tee 3/4" JIC Male Tee | 0324-S19-121212 | 2   |

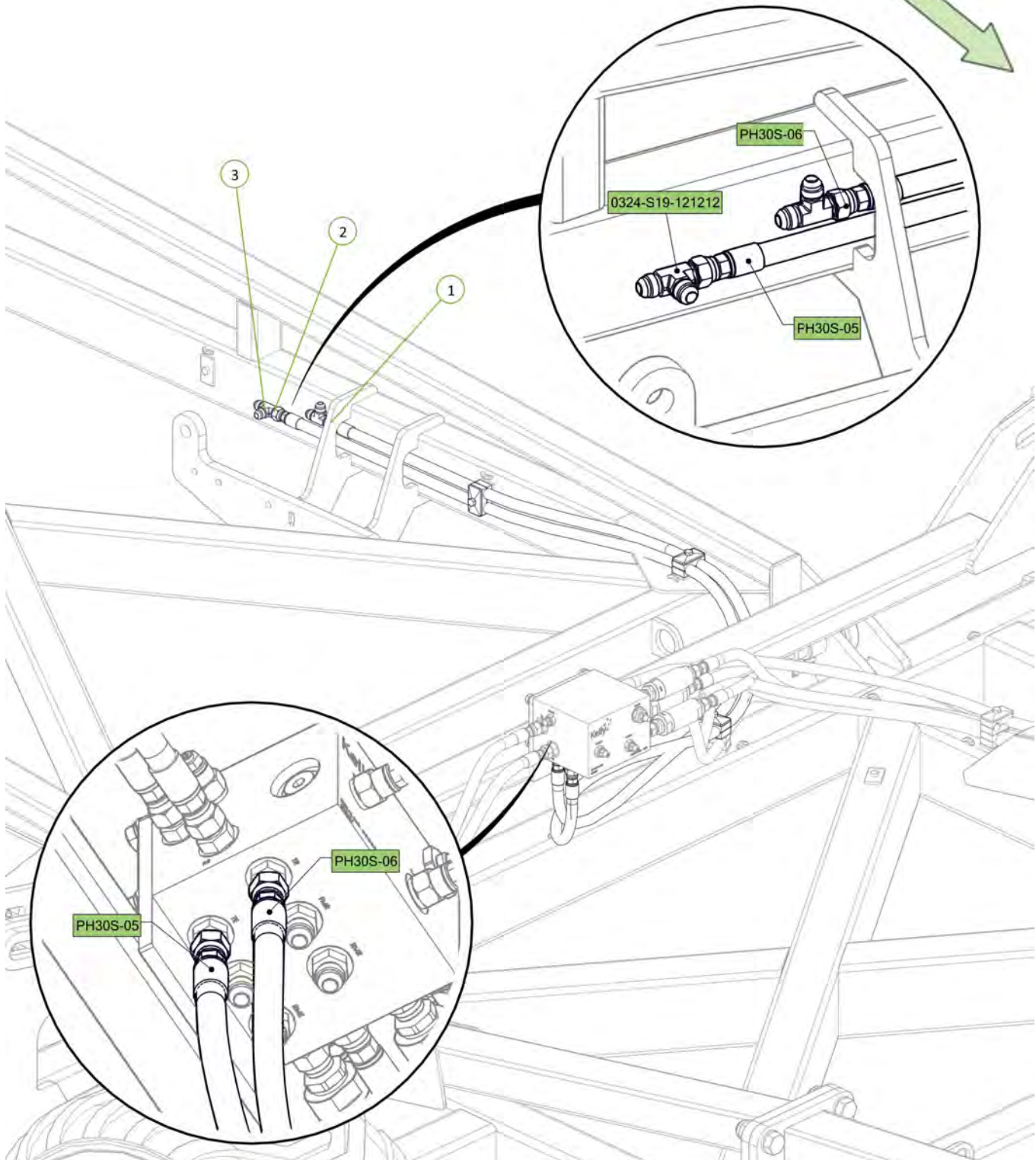
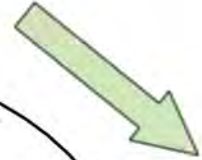



| Item No. | Description   | Number          | Qty |
|----------|---|-----------------|-----|
| 1        | Tail Extend Tee to Rear Extend Tee                    | PH30S-07        | 1   |
| 2        | Tail Retract Tee to Rear Retract Tee                  | PH30S-08        | 1   |
| 3        | 3/4" JIC Male Tee 3/4" JIC Male Tee 3/4" JIC Male Tee | 0324-S19-121212 | 2   |

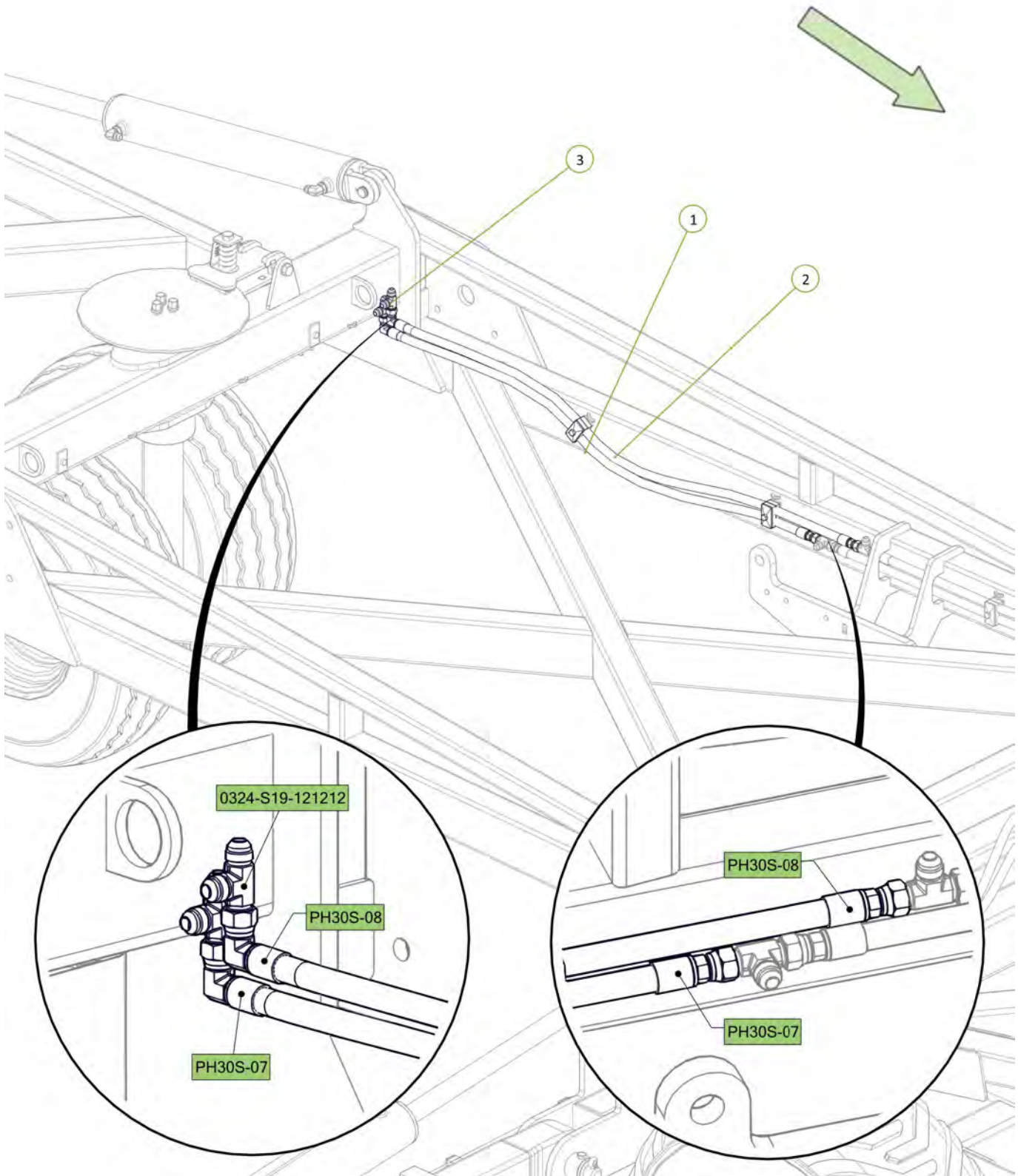

| Item No. | Description                                   | Number   | Qty |
|----------|---|----------|-----|
| 1        | Rear Extend Tee to Rear Port LH Tail Cylinder | PH30S-09 | 1   |
| 2        | Rear Retract Tee to Rod Port Tail LH Cylinder | PH30S-10 | 1   |

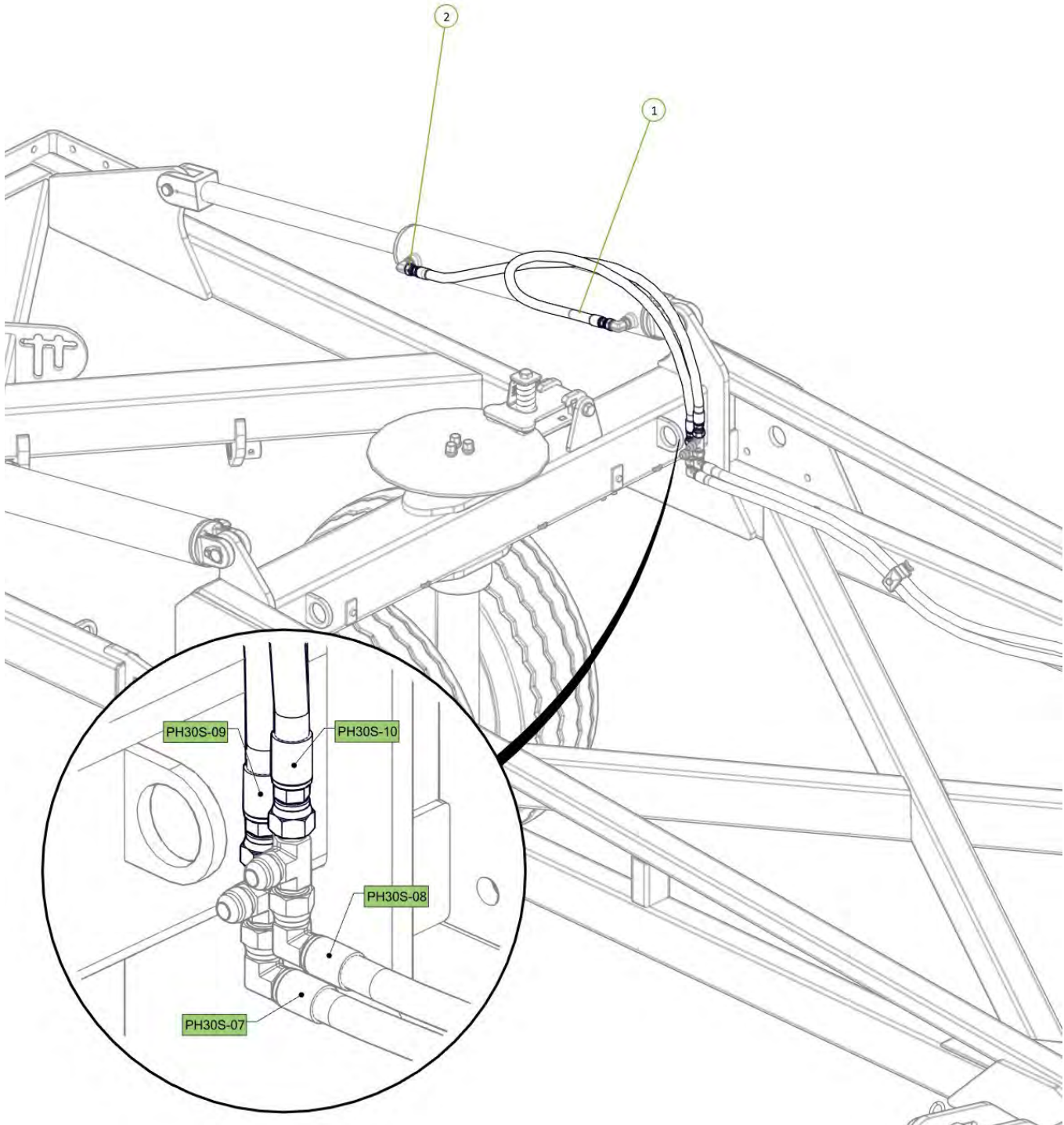



| Item No. | Description                                   | Number   | Qty |
|----------|---|----------|-----|
| 1        | Rear Extend Tee to Rear Port RH Tail Cylinder | PH30S-11 | 1   |
| 2        | Rear Retract Tee to Rod Port RH Tail Cylinder | PH30S-12 | 1   |

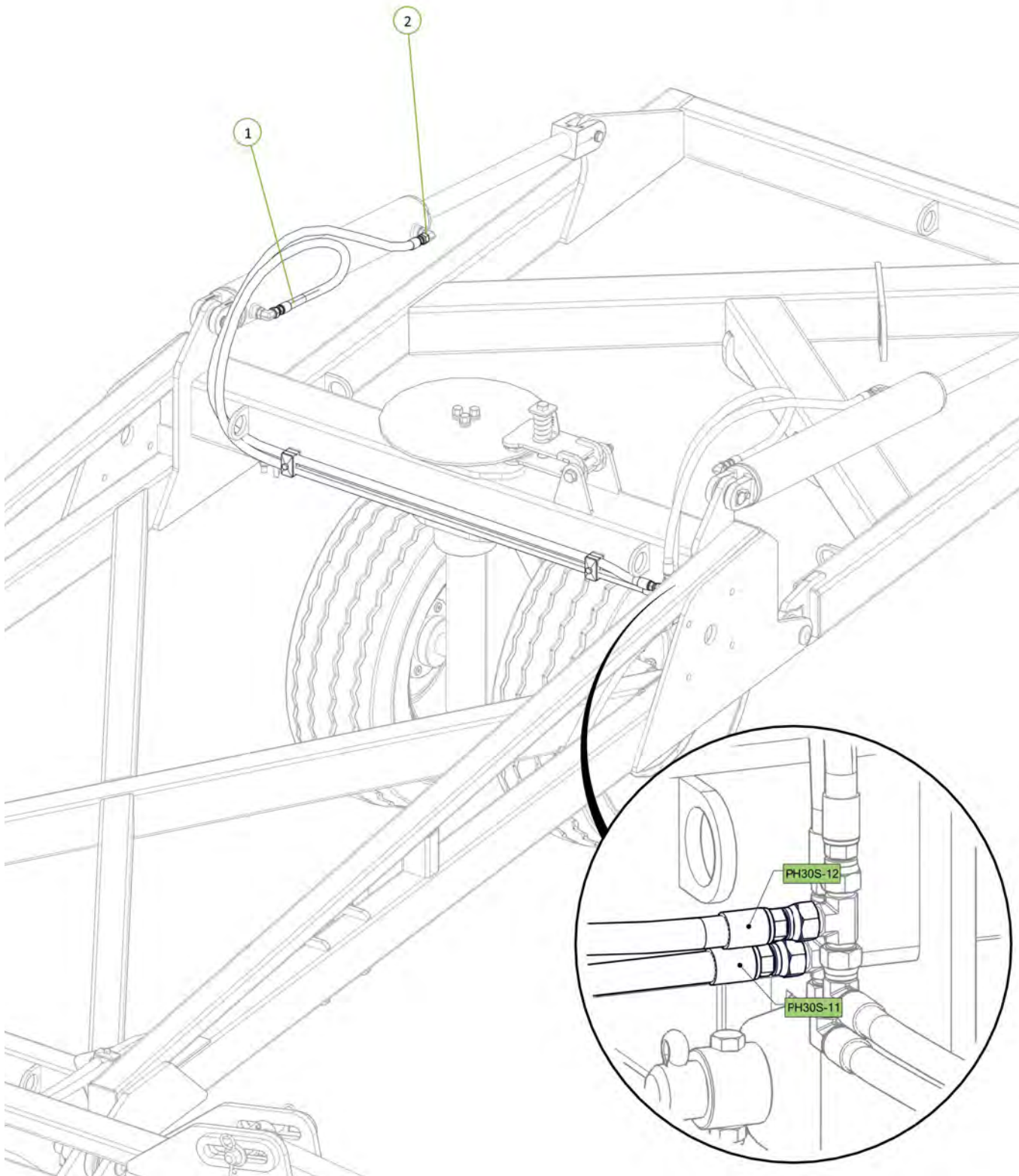

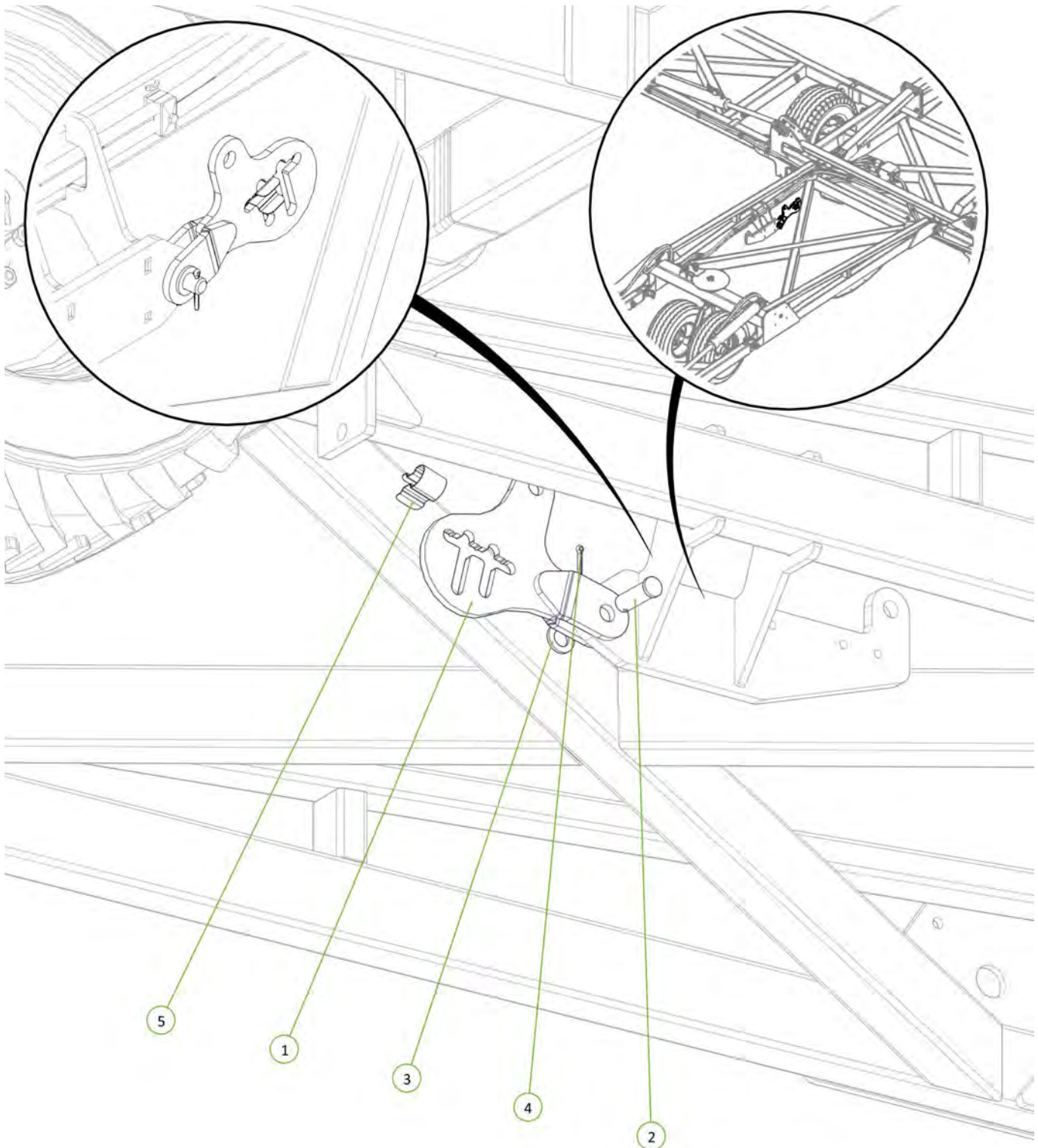

| Item No. | Description                    | Number        | Qty |
|----------|--------------------------------|---------------|-----|
| 1        | Reduced Lift Arm               | 0810-84       | 1   |
| 2        | Clevis Pin 25mm x 75mm         | 0801-KE0307-1 | 1   |
| 3        | Washer Flat M24                | 0231-F24      | 1   |
| 4        | Cotter Pin M5 x 50             | 0261-PINC550  | 1   |
| 5        | Height Adjuster Retaining Clip | 0801-KE014    | 1   |



| Item No. | Description                                       | Number     | Qty |
|----------|---|------------|-----|
| 1        | 2.5" Bore x 6" Stroke 1.5" Rod Side Port Cylinder | 0311-256SP | 1   |

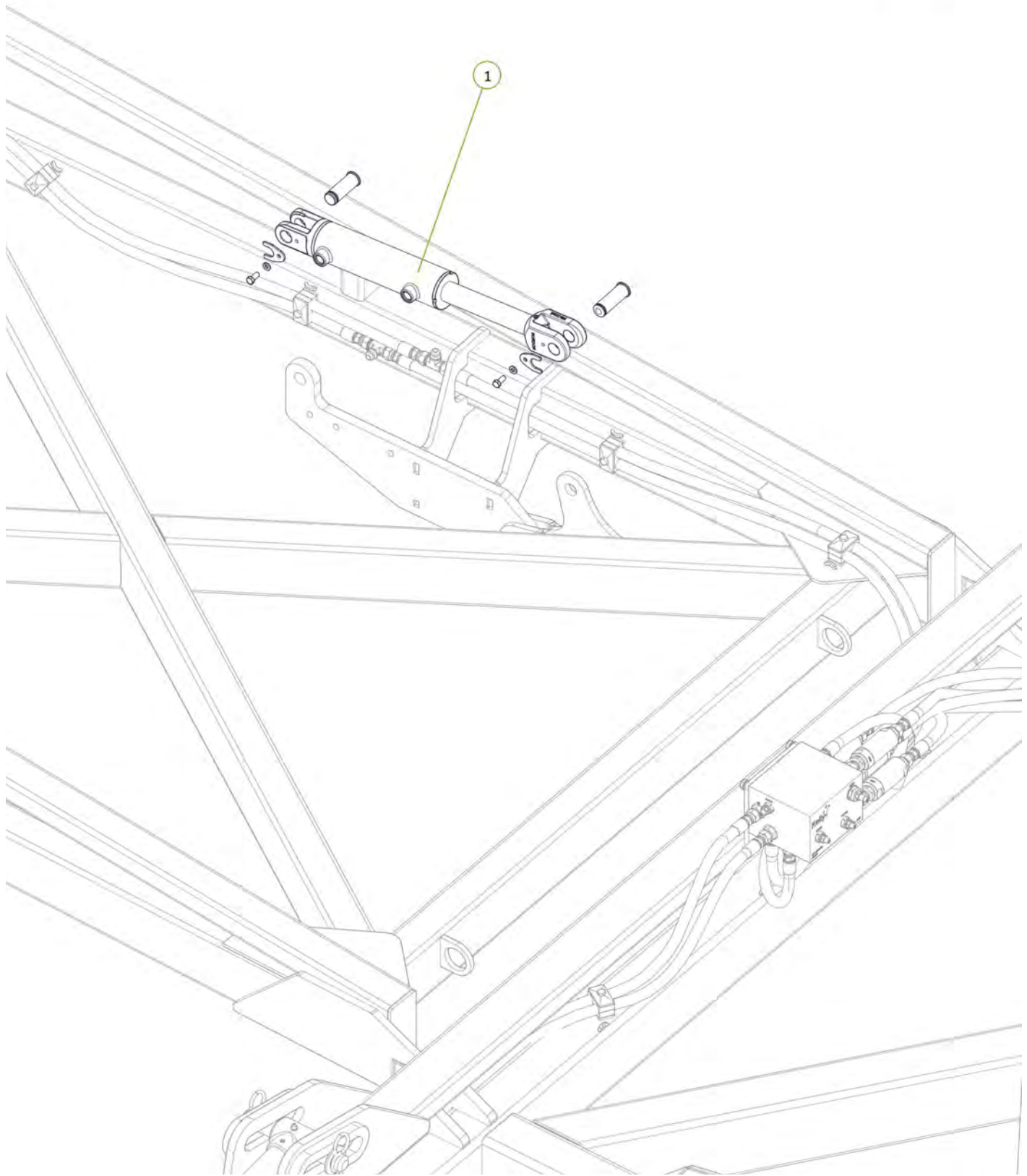



| Item No. | Description                                 | Number        | Qty |
|----------|---|---------------|-----|
| 1        | 3/4" JIC Male 3/4" UN O Ring Male 90° Elbow | 0323-S91-1212 | 2   |

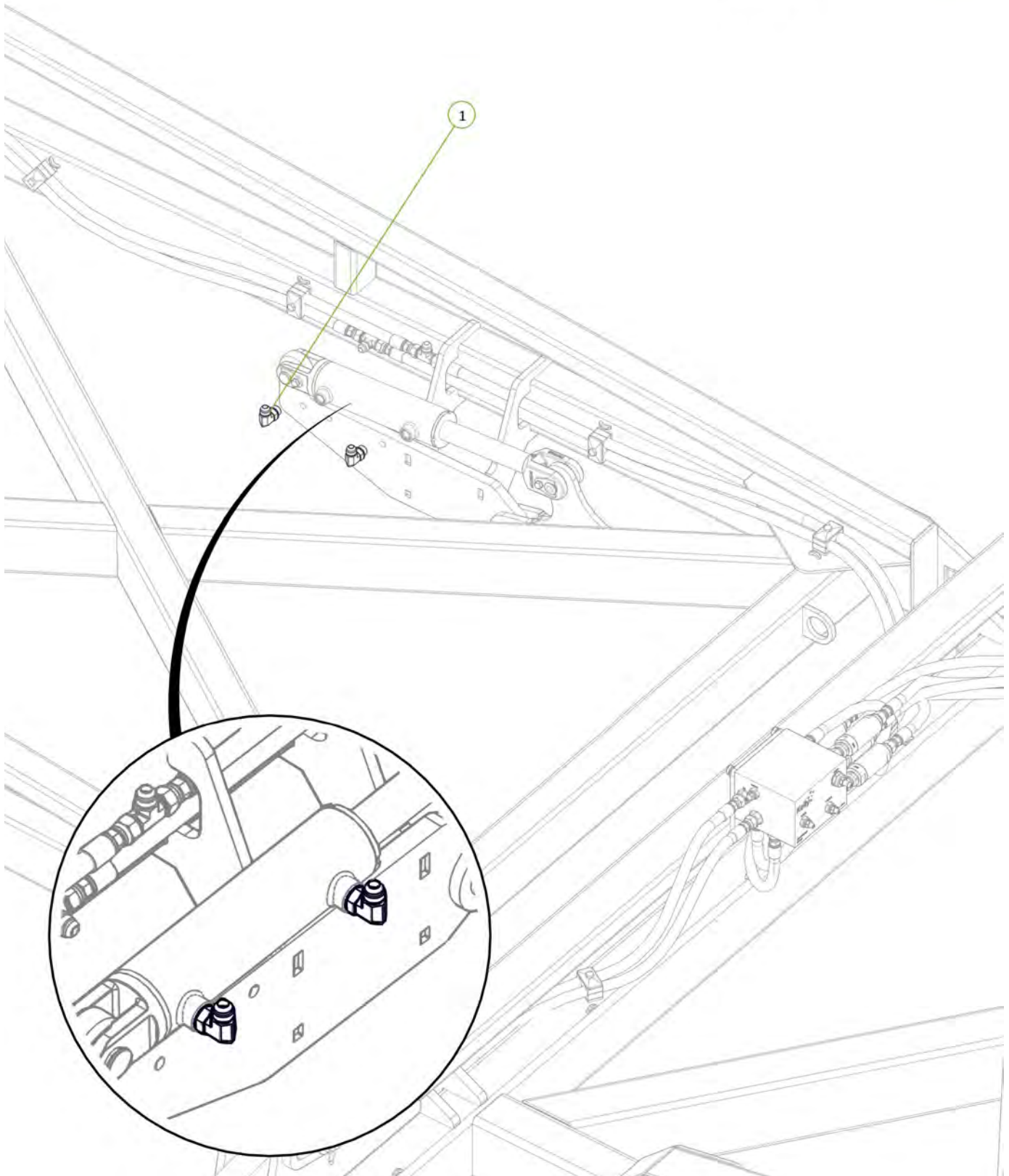



| Item No. | Description  | Number   | Qty |
|----------|--|----------|-----|
| 1        | Tail Extend Tee to Rear Port Left Rear Module Cylinder | PH30S-13 | 1   |
| 2        | Tail Retract Tee to Rod Port Left Rear Module Cylinder | PH30S-14 | 1   |

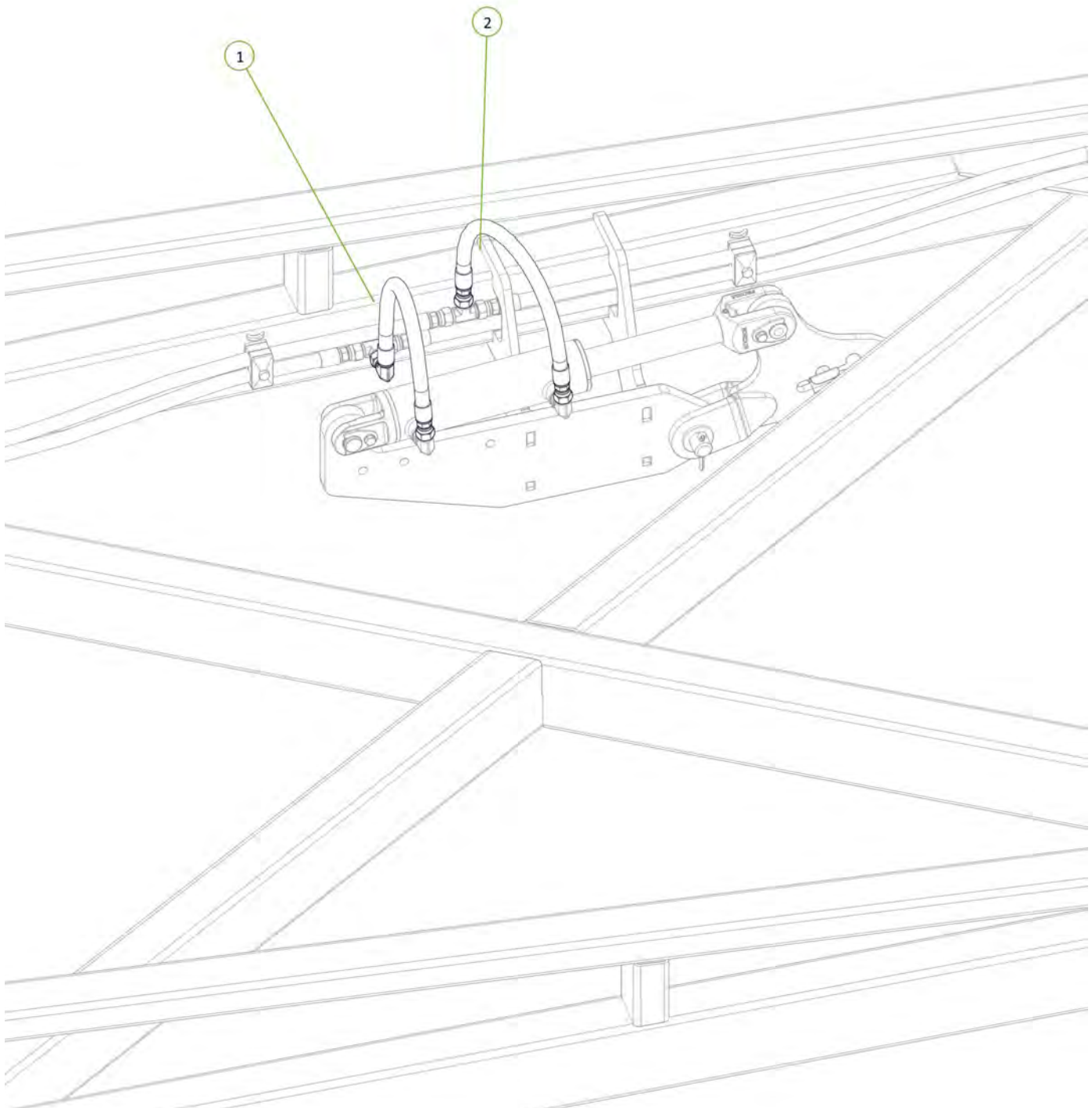

| Item No. | Description                   | Number     | Qty |
|----------|-------------------------------|------------|-----|
| 1        | Extended Tip Tail Bolt On Tip | 0810-10ET  | 1   |
| 2        | M16 x 50 grade 8.8 zp Bolt    | 0211-1650  | 9   |
| 3        | Nyloc Nut M16                 | 0221-NYL16 | 10  |
| 4        | Washer Flat M16               | 0231-F16   | 20  |

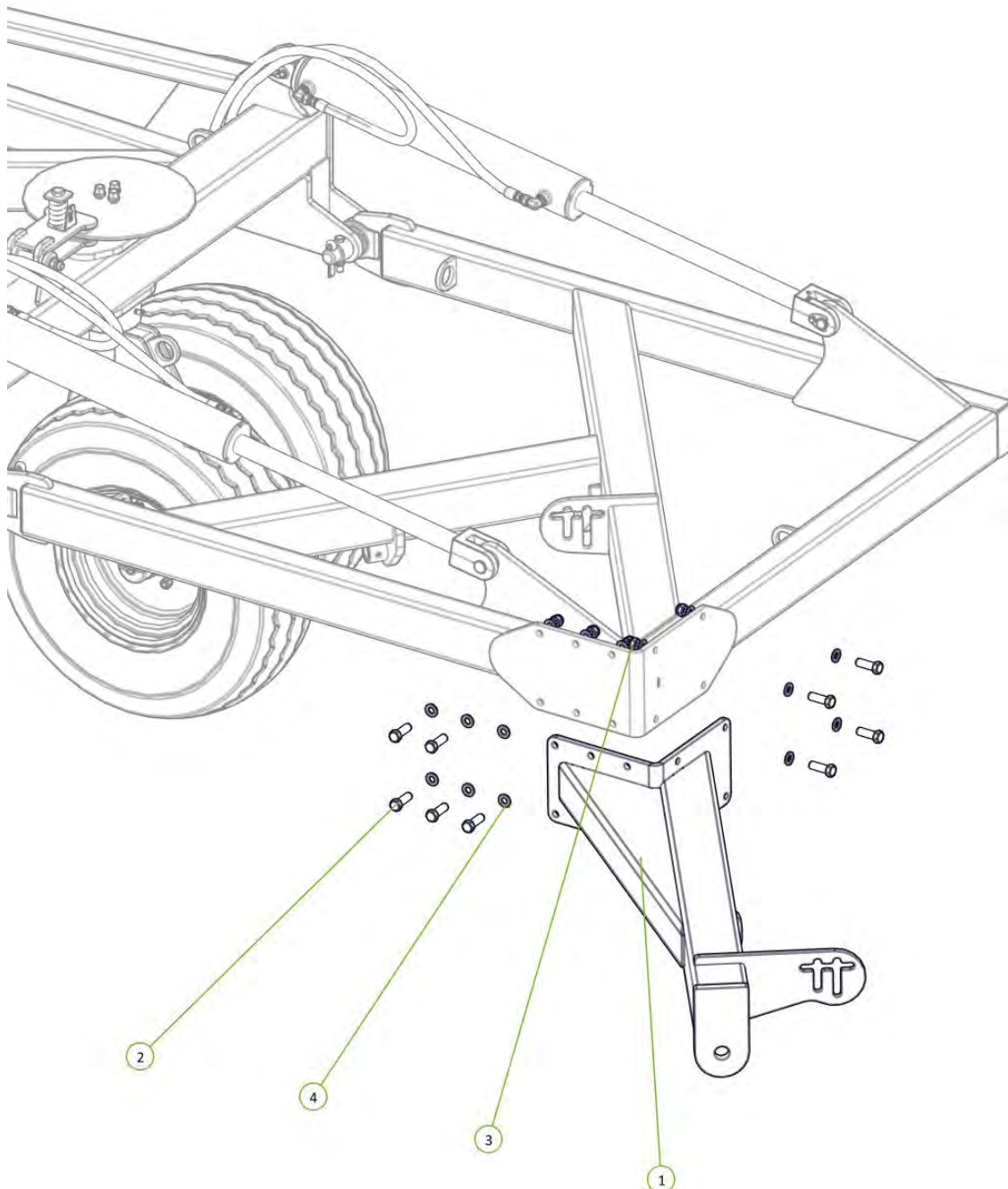

| Item No. | Description                      | Number        | Qty |
|----------|----------------------------------|---------------|-----|
| 1        | 30' Front Module                 | 0810-28-30-2  | 1   |
| 2        | U-Bolt M16 x 190 Deep X 106 Wide | 0271-16185104 | 8   |
| 3        | Nyloc Nut M16                    | 0221-NYL16    | 16  |
| 4        | Washer Flat M16                  | 0231-F16      | 16  |

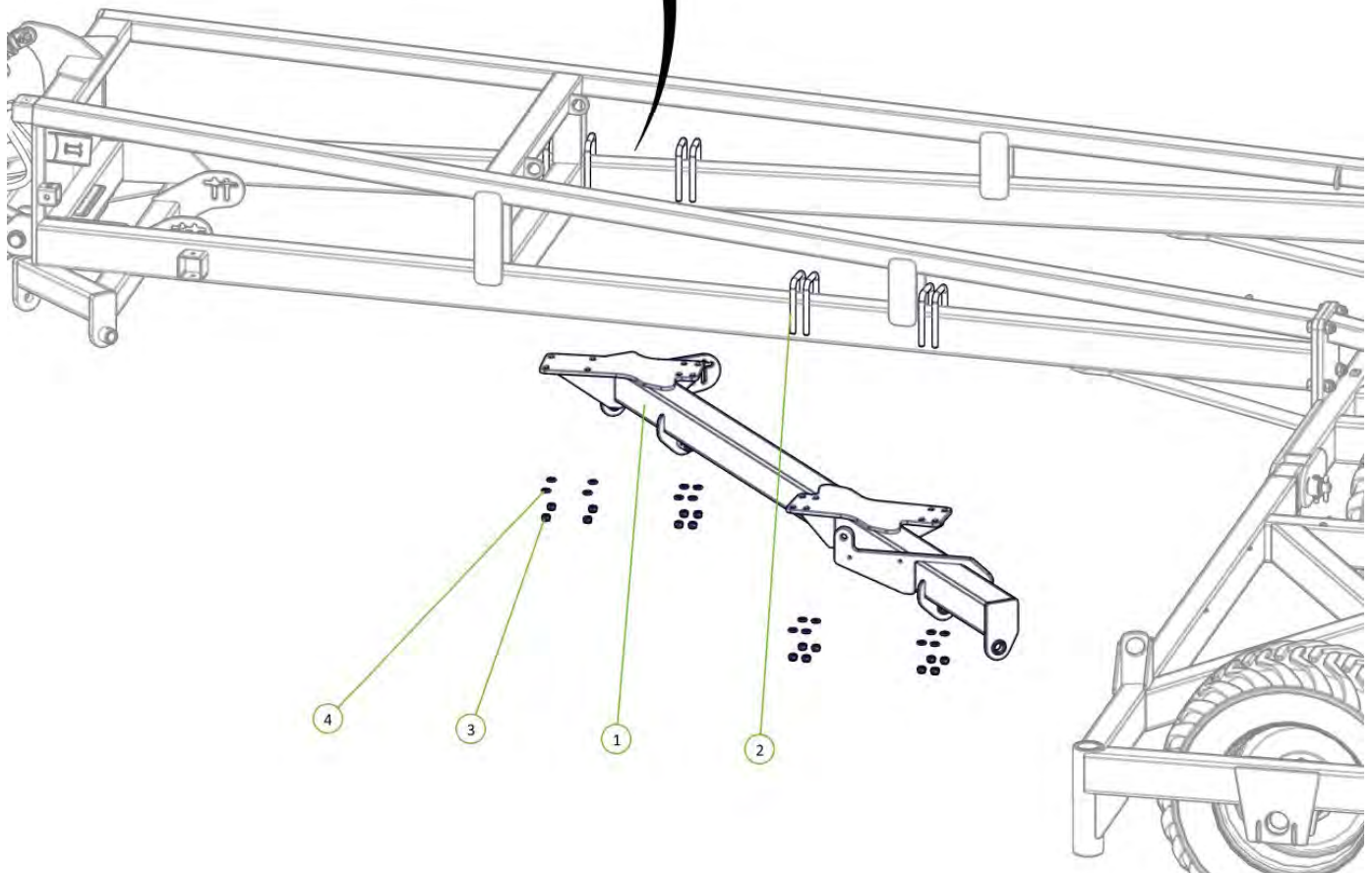



| Item No. | Description                     | Number       | Qty |
|----------|---------------------------------|--------------|-----|
| 1        | 30' Rear Module                 | 0810-29-30-2 | 1   |
| 2        | U-Bolt M16 x 160 Deep X 77 Wide | 0271-1616077 | 7   |
| 3        | Washer Flat M16                 | 0231-F16     | 14  |
| 4        | Nyloc Nut M16                   | 0221-NYL16   | 14  |

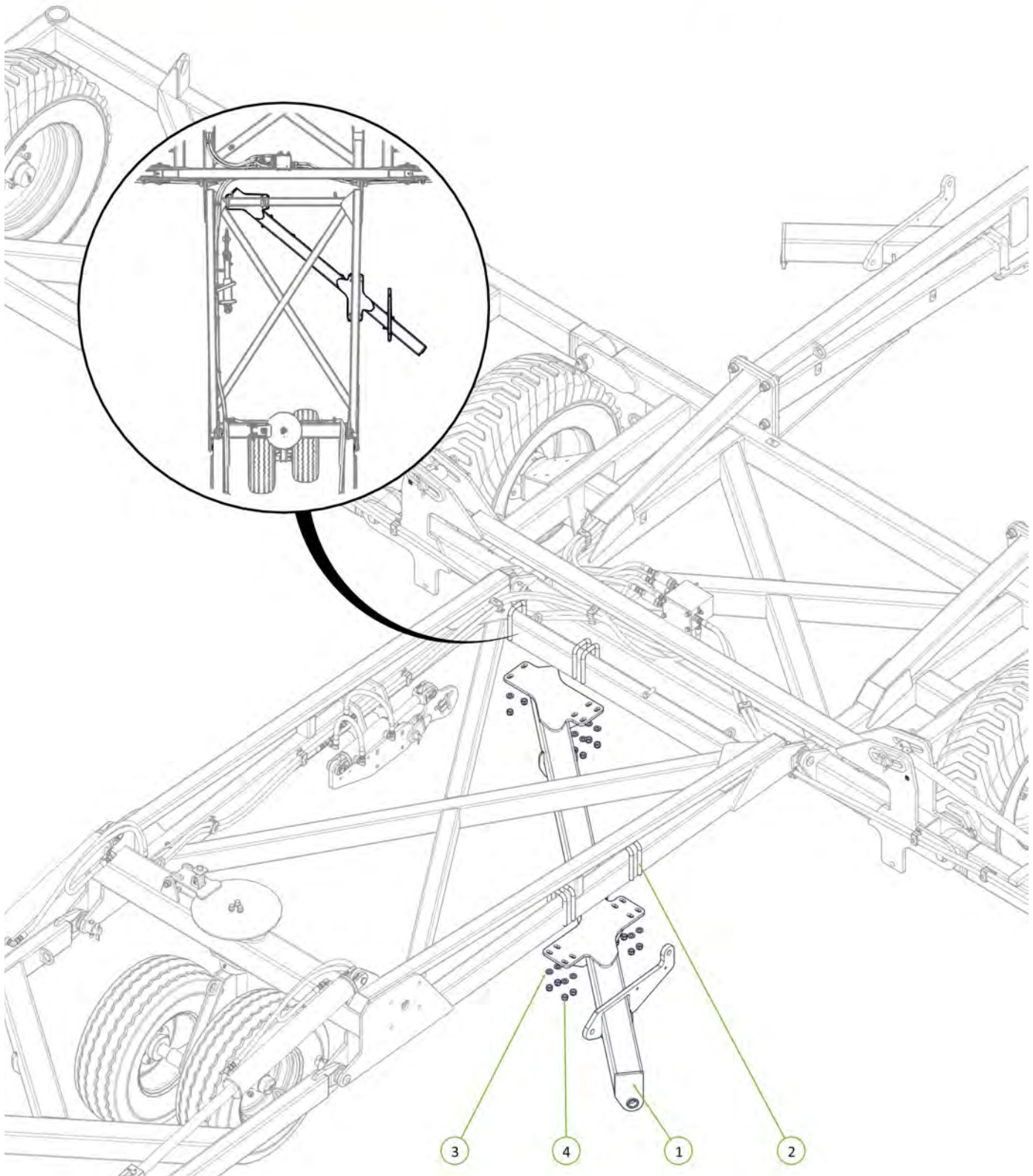



| Item No. | Description                        | Number         | Qty |
|----------|------------------------------------|----------------|-----|
| 1        | Super Single LH Drop Leg No Clevis | 0810-24SF      | 1   |
| 2        | Super Single RH Drop Leg No Clevis | 0810-25SF      | 1   |
| 3        | LH Chain Adjusting Lug             | 0810-26        | 1   |
| 4        | RH Chain Adjusting Lug             | 0810-27        | 1   |
| 5        | Forged Clevis 21mm Bolt Hole       | 0801-FC21      | 2   |
| 6        | M36 x 110 grade 8.8 zp Bolt        | 0211-36        | 2   |
| 7        | M24 x 140 grade 8.8 zp Bolt        | 0211-24140     | 2   |
| 8        | Nyloc Nut M24                      | 0221-NYL24     | 2   |
| 9        | Nyloc Nut M36                      | 0221-NYL36     | 2   |
| 10       | Stainless Steel Wear Bush          | 1501-365033-SS | 2   |

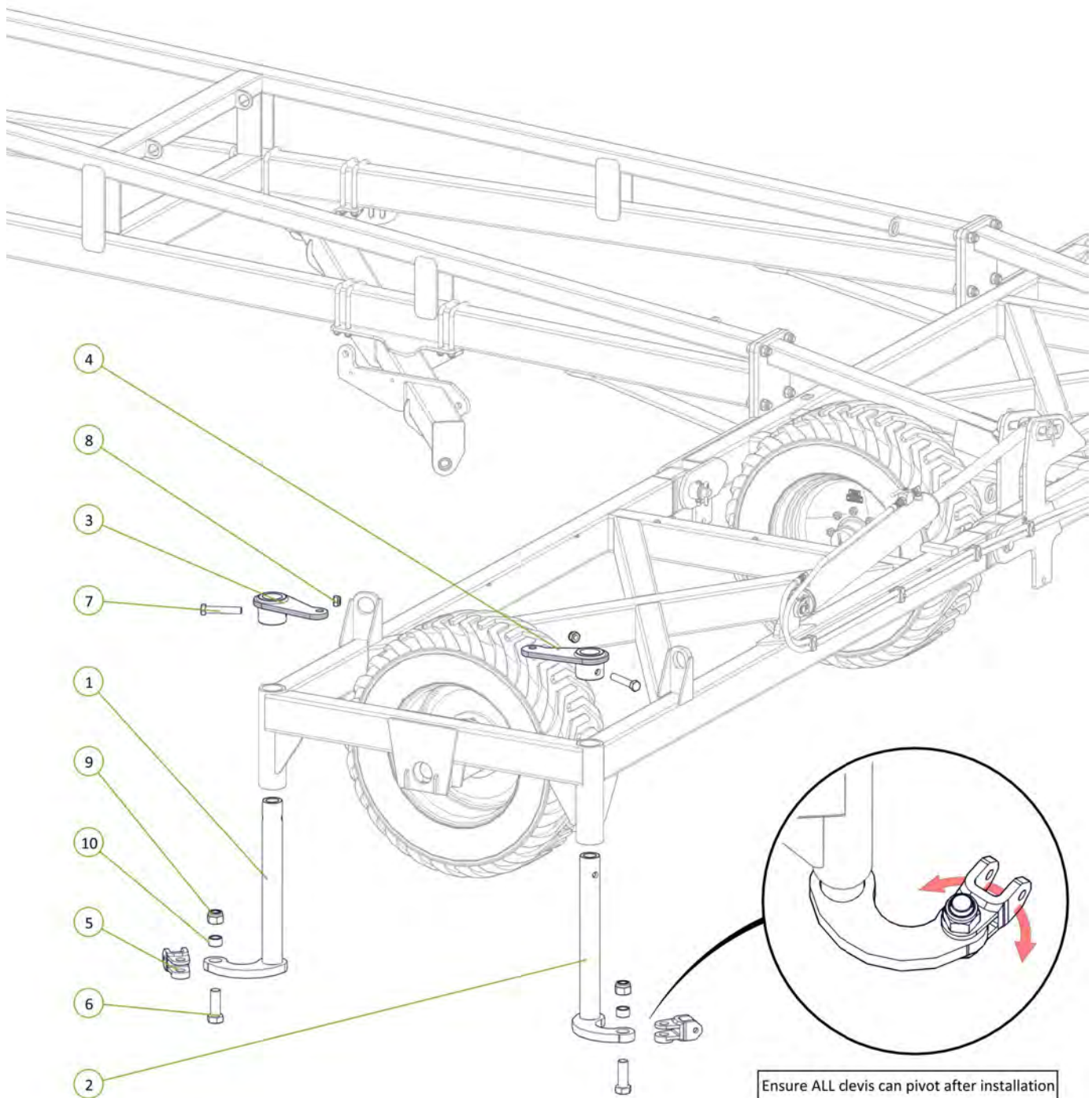

Ensure ALL devis can pivot after installation

| Item No. | Description                | Number    | Qty |
|----------|----------------------------|-----------|-----|
| 1        | Cast 25mm Spacing Half     | 0801-CS25 | 24  |
| 2        | M10 x 30 Class 8.8 ZP Bolt | 0211-10   | 24  |
| 3        | Nyloc Nut M10              | 0221-NYL  | 24  |

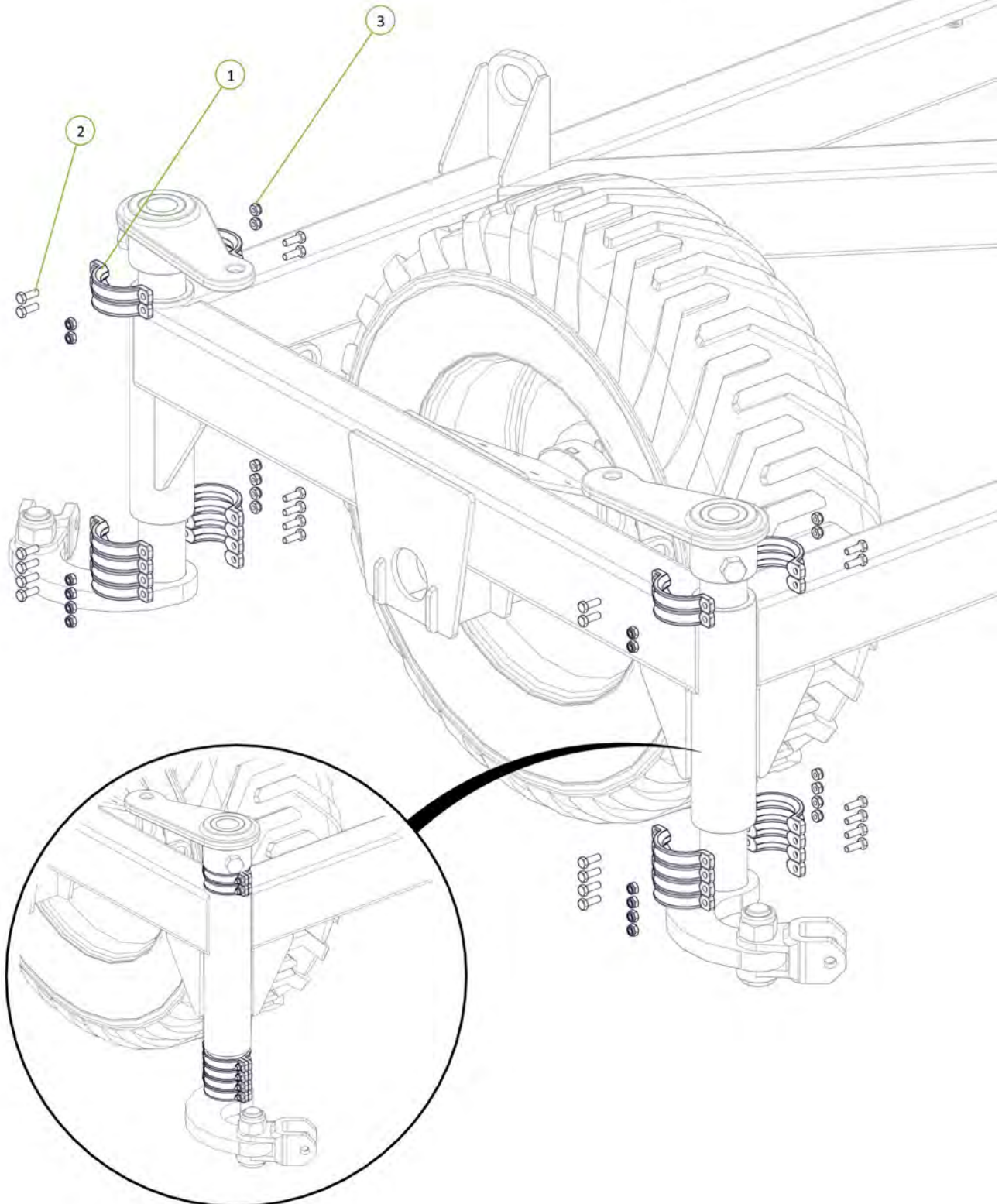

| Item No. | Description                | Number        | Qty |
|----------|----------------------------|---------------|-----|
| 1        | Chain Tension Adjustor     | 0802-PCHTA    | 2   |
| 2        | Washer High Tensile 1 1/4" | 0232-HT11-4   | 2   |
| 3        | 20mm Compression Spring    | 0801-XK9261S  | 2   |
| 4        | Tensioner Cup - Male       | 0801-KE0805-3 | 2   |
| 5        | Female Spring Locator      | 0801-KE0805-4 | 2   |

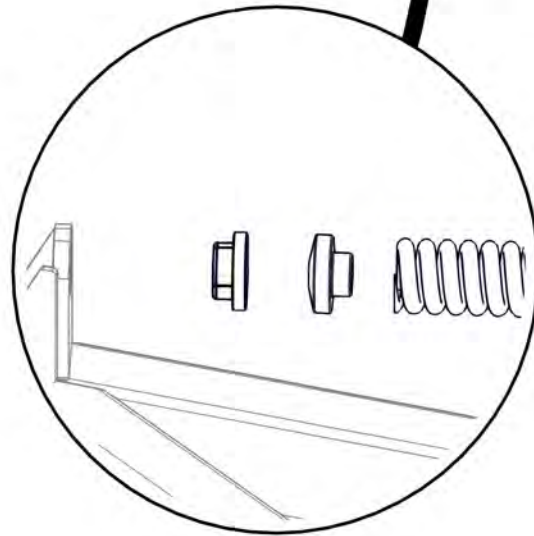
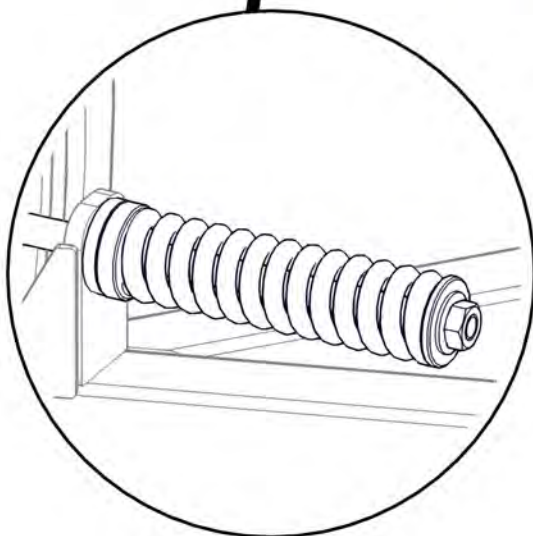
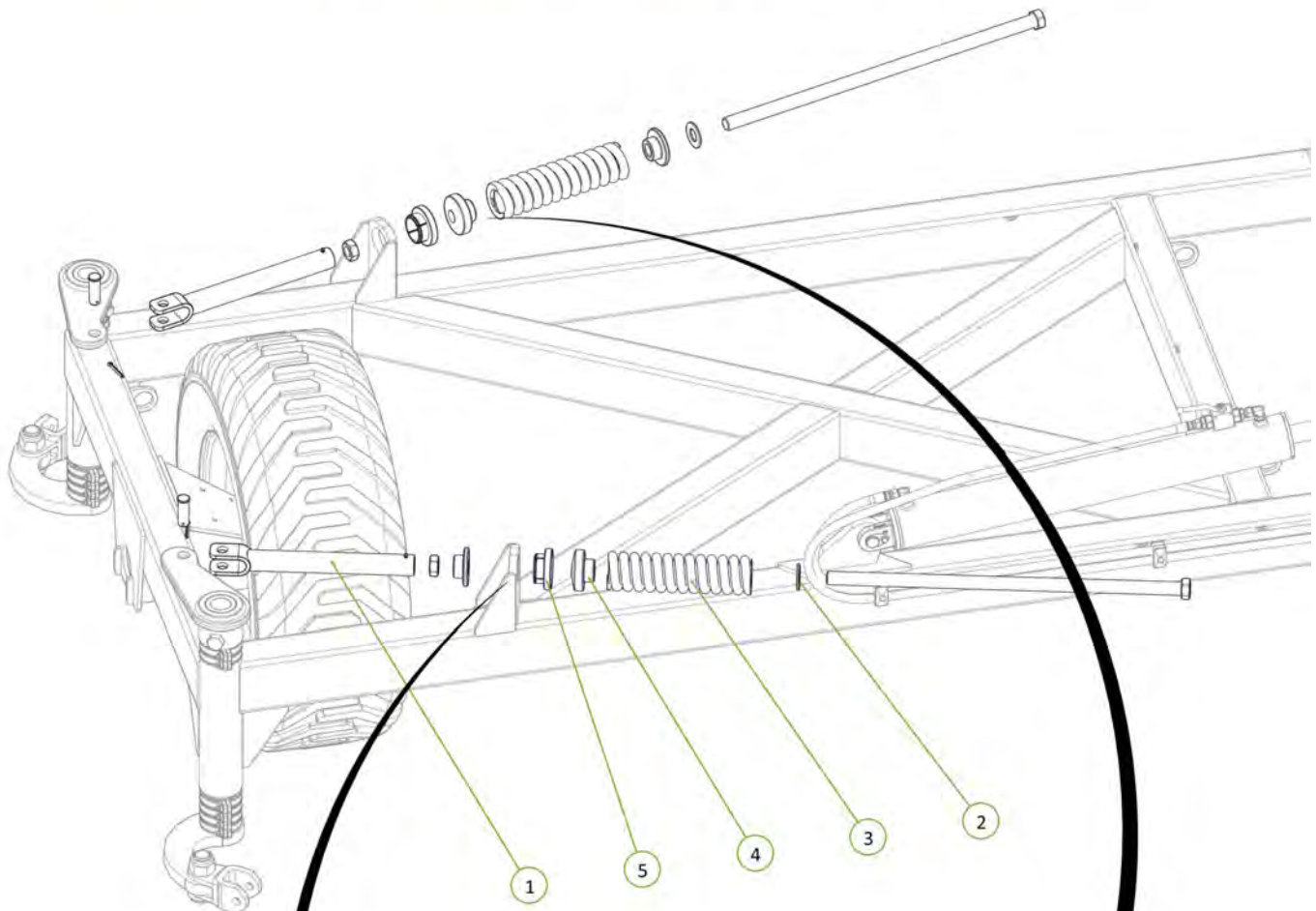



| Item No. | Description                        | Number         | Qty |
|----------|------------------------------------|----------------|-----|
| 1        | Super Single LH Drop Leg No Clevis | 0810-24SF      | 1   |
| 2        | Super Single RH Drop Leg No Clevis | 0810-25SF      | 1   |
| 3        | LH Chain Adjusting Lug             | 0810-26        | 1   |
| 4        | RH Chain Adjusting Lug             | 0810-27        | 1   |
| 5        | Stainless Steel Wear Bush          | 1501-365033-SS | 2   |
| 6        | Forged Clevis 21mm Bolt Hole       | 0801-FC21      | 2   |
| 7        | M36 x 110 grade 8.8 zp Bolt        | 0211-36110     | 2   |
| 8        | Nyloc Nut M36                      | 0221-NYL36     | 2   |
| 9        | M24 x 140 grade 8.8 zp Bolt        | 0211-24140     | 2   |
| 10       | Nyloc Nut M24                      | 0221-NYL24     | 2   |

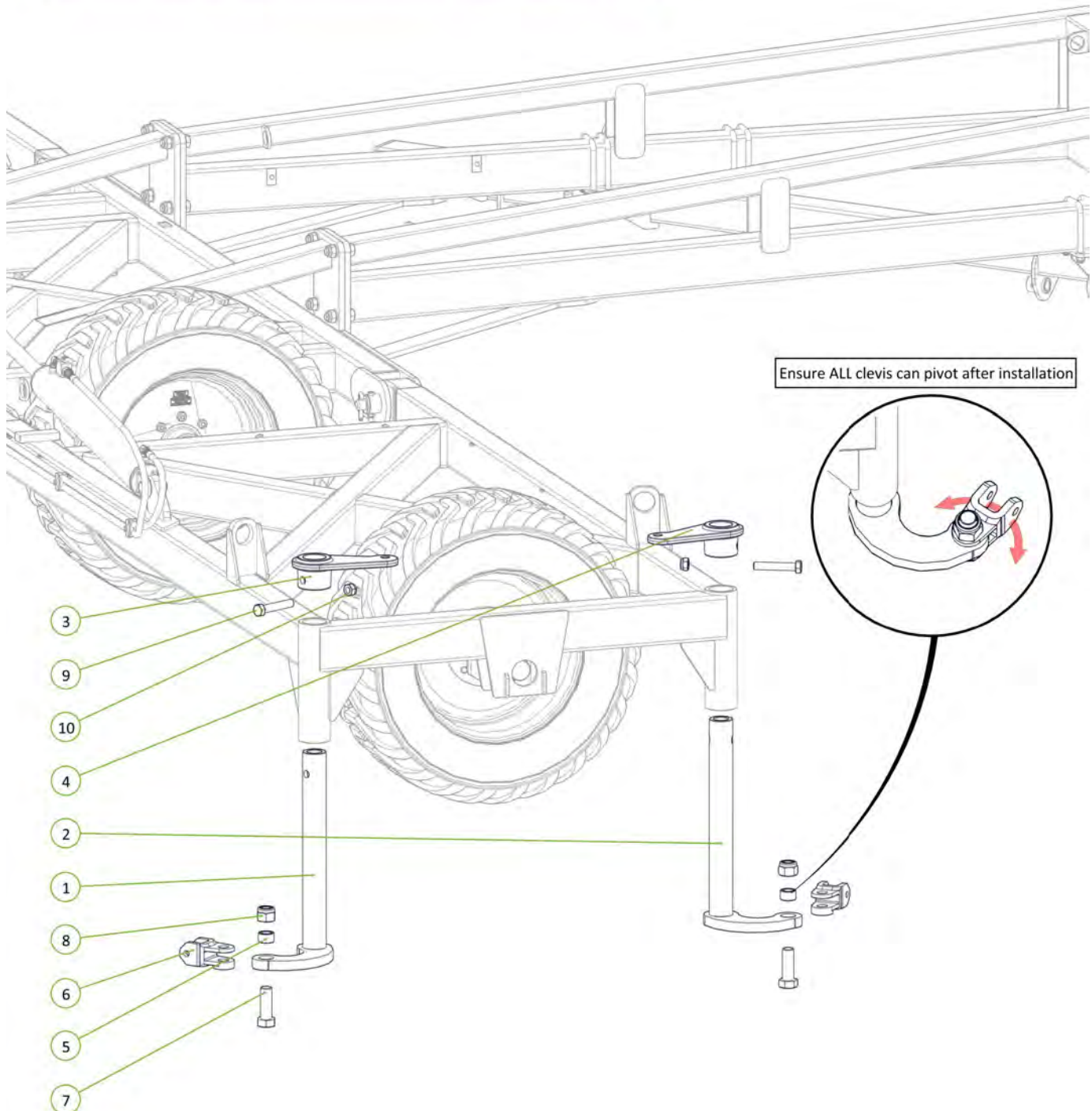



| Item No. | Description                | Number    | Qty |
|----------|----------------------------|-----------|-----|
| 1        | Cast 25mm Spacing Half     | 0801-CS25 | 24  |
| 2        | M10 x 30 Class 8.8 ZP Bolt | 0211-10   | 24  |
| 3        | Nyloc Nut M10              | 0221-NYL  | 24  |

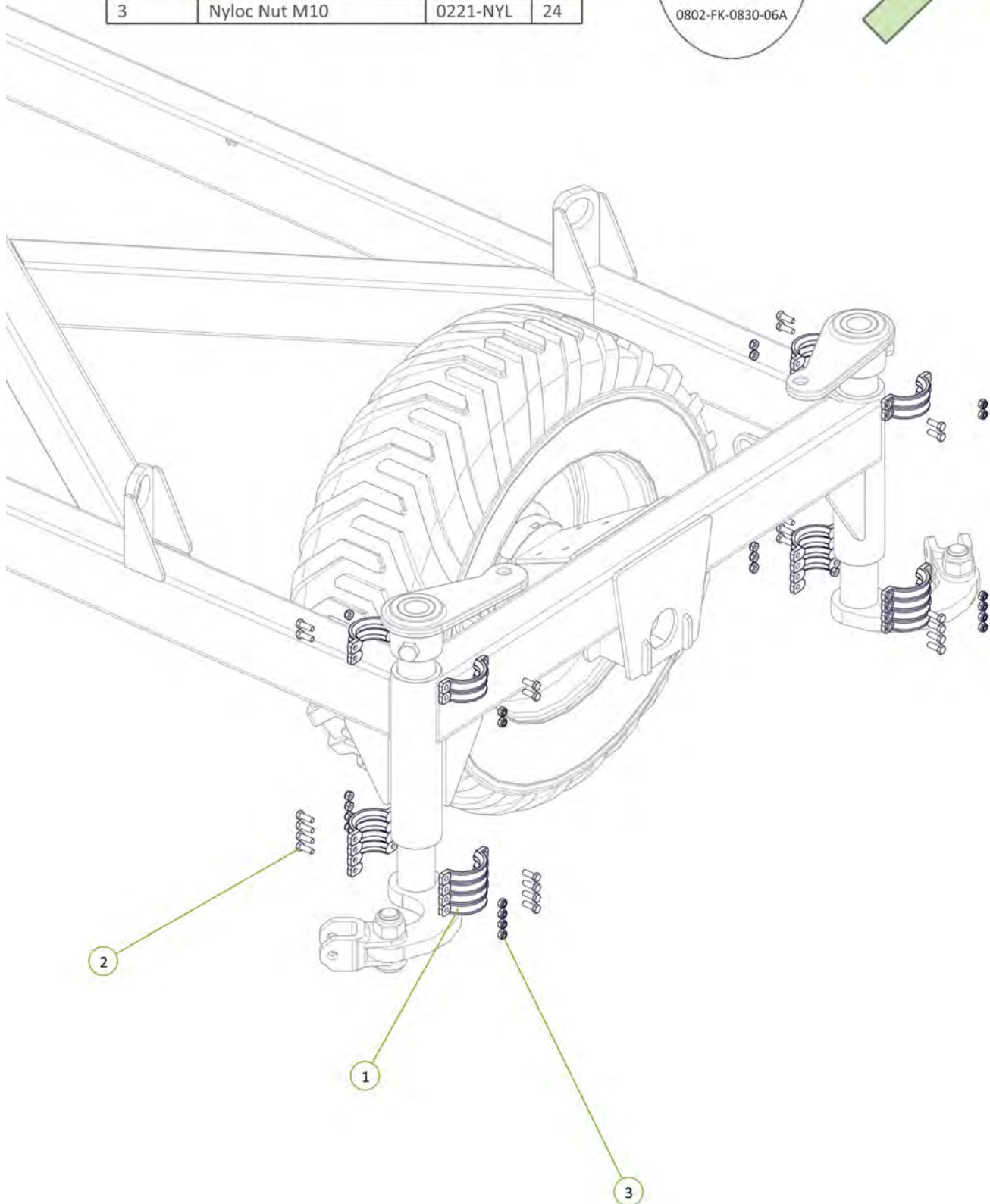

| Item No. | Description                | Number        | Qty |
|----------|----------------------------|---------------|-----|
| 1        | Chain Tension Adjustor     | 0802-PCHTA    | 2   |
| 2        | Washer High Tensile 1 1/4" | 0232-HT11-4   | 2   |
| 3        | 20mm Compression Spring    | 0801-XK9261S  | 2   |
| 4        | Tensioner Cup - Male       | 0801-KE0805-3 | 2   |
| 5        | Female Spring Locator      | 0801-KE0805-4 | 2   |

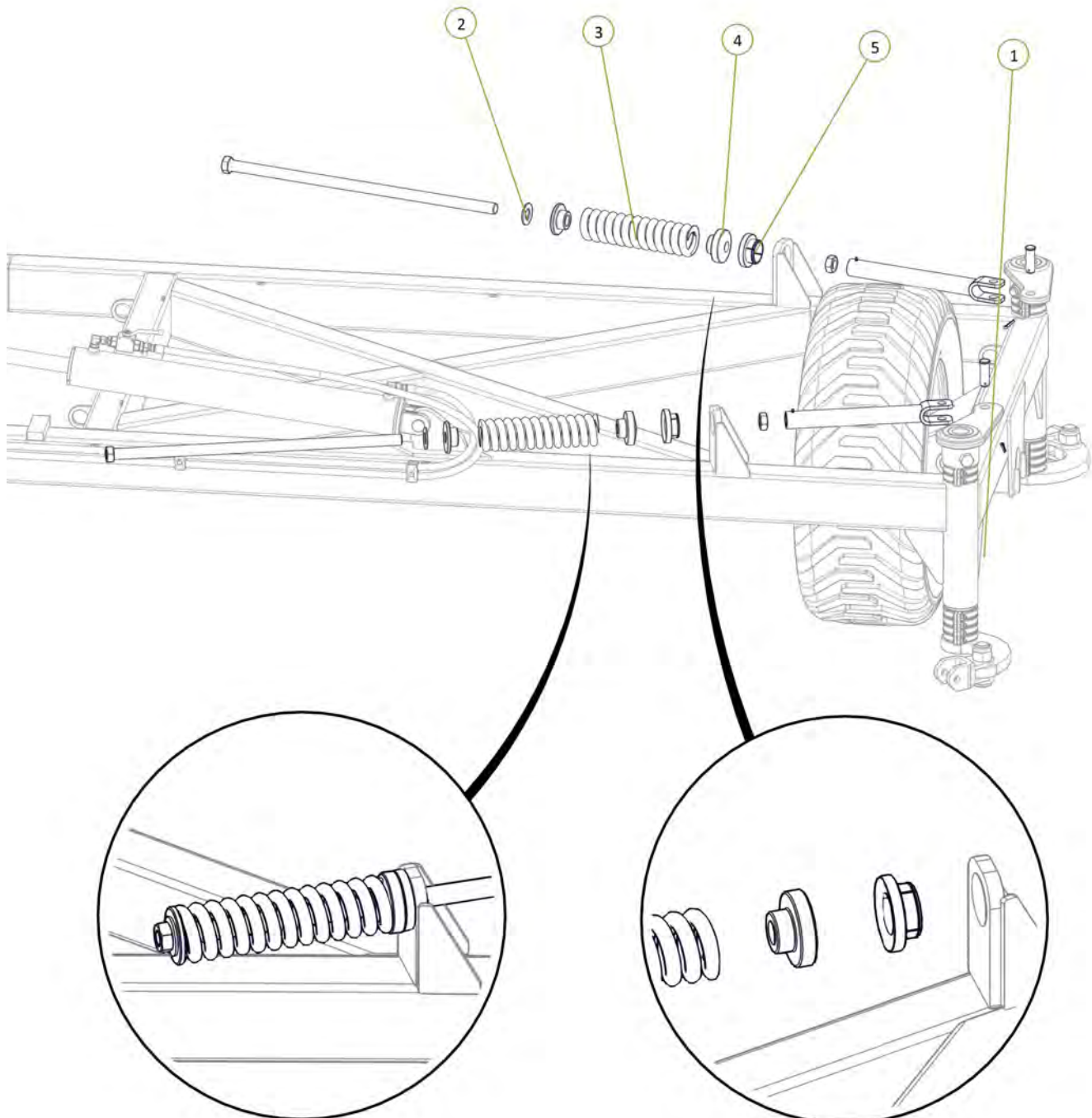

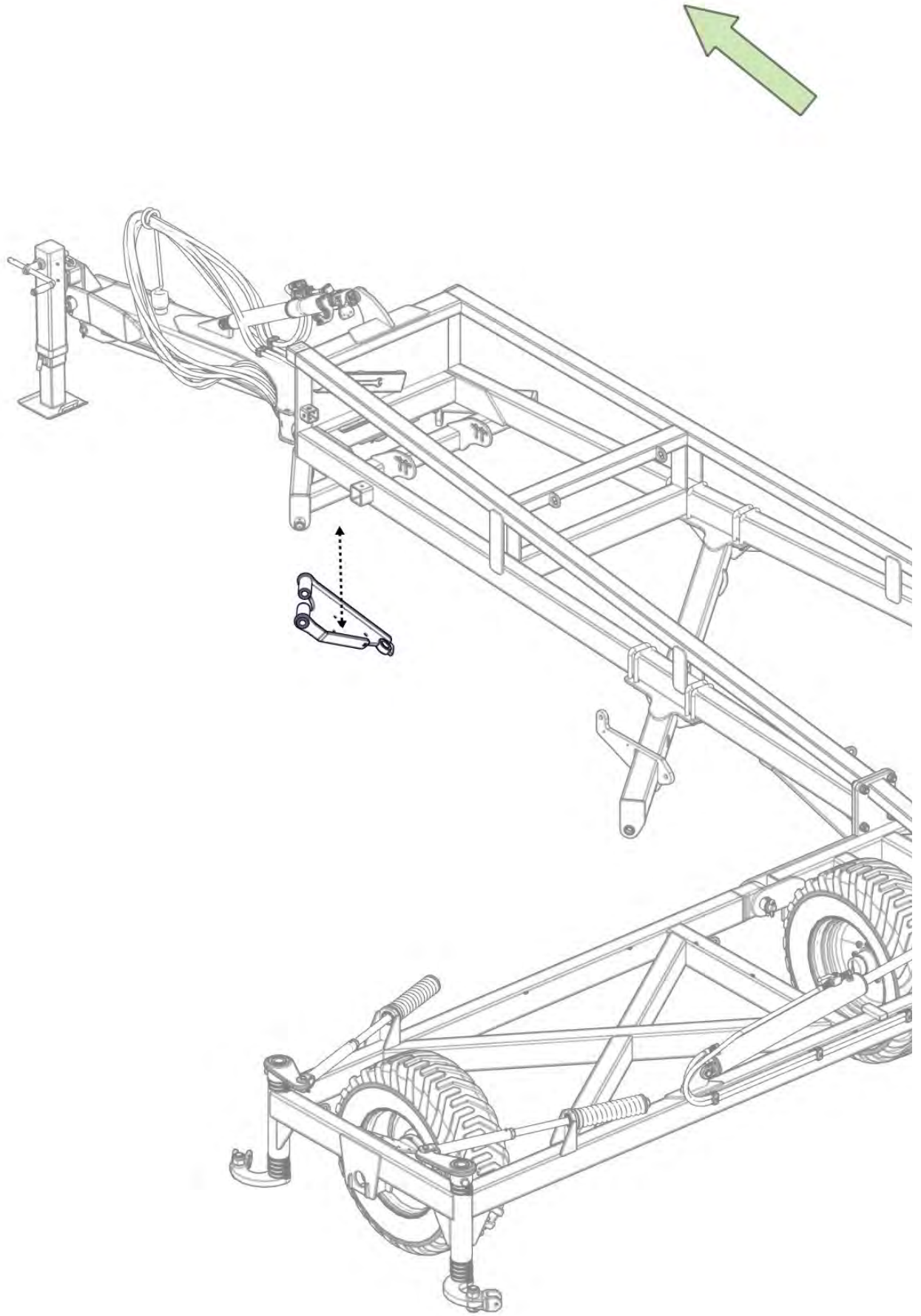



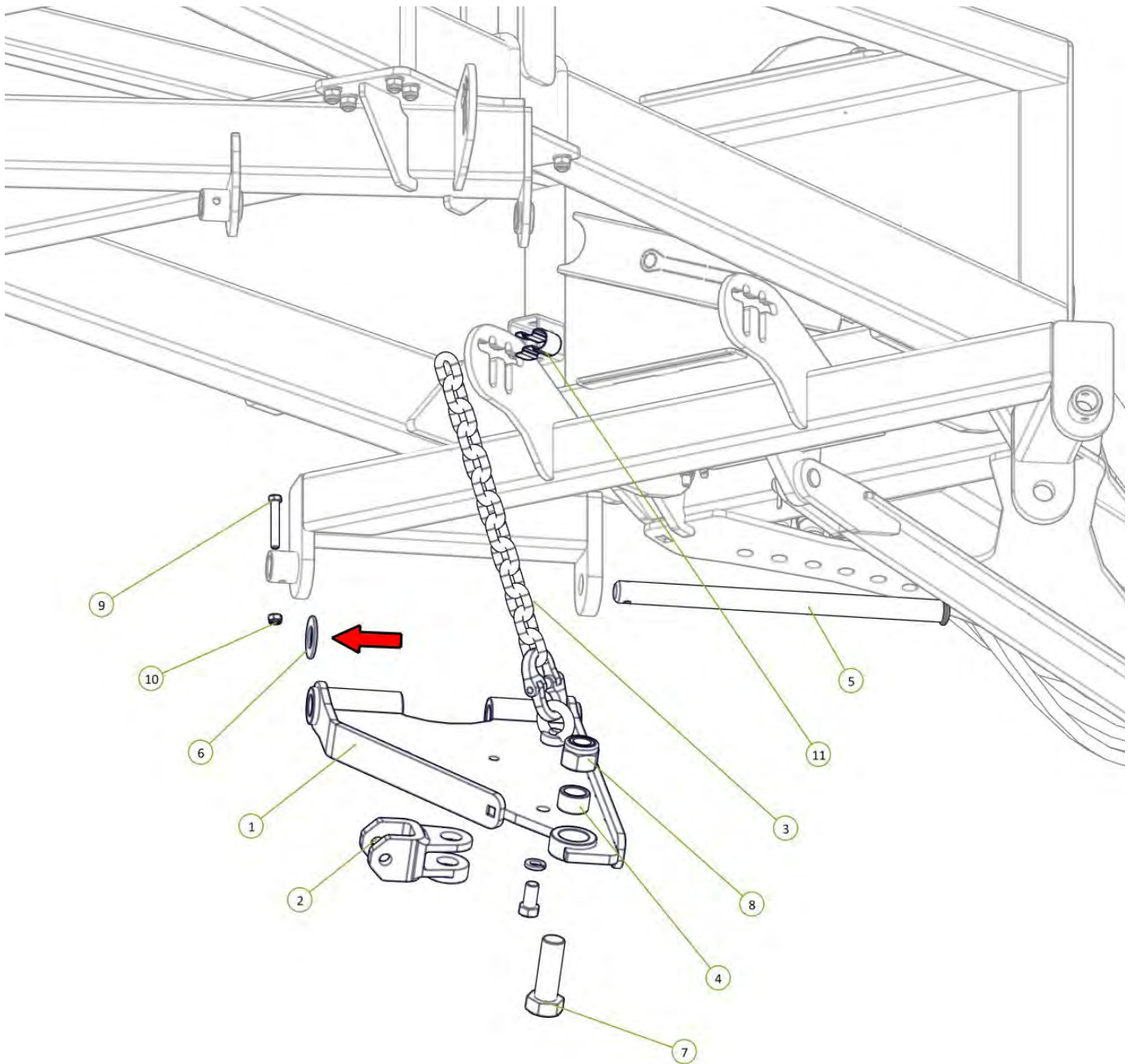

| Item No. | Description                             | Number         | Qty |
|----------|---|----------------|-----|
| 1        | Standard Chain Mount Plate              | 0810-20        | 1   |
| 2        | Forged Clevis 21mm Bolt Hole            | 0801-FC21      | 1   |
| 3        | Height Adjusting Chain Assembly 13 Link | 0801-20MCA     | 1   |
| 4        | Stainless Steel Wear Bush               | 1501-365033-SS | 1   |
| 5        | Chain Mount Pivot Pin                   | 0801-10-51     | 1   |
| 6        | Washer High Tensile 1 3/8"              | 0232-HT13-8    | 1   |
| 7        | M36 x 105 grade 8.8 zp Bolt             | 0211-36105     | 1   |
| 8        | Nyloc Nut M36                           | 0221-NYL36     | 1   |
| 9        | M12 x 80 Class 8.8 ZP Bolt              | 0211-1280      | 1   |
| 10       | Nyloc Nut M12                           | 0221-NYL12     | 1   |
| 11       | Height Adjustor Retaining Clip          | 0801-KE014     | 1   |





0802-FK-0830-02A

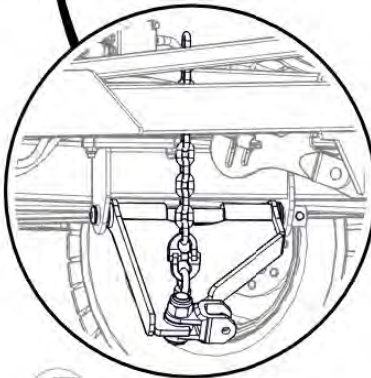
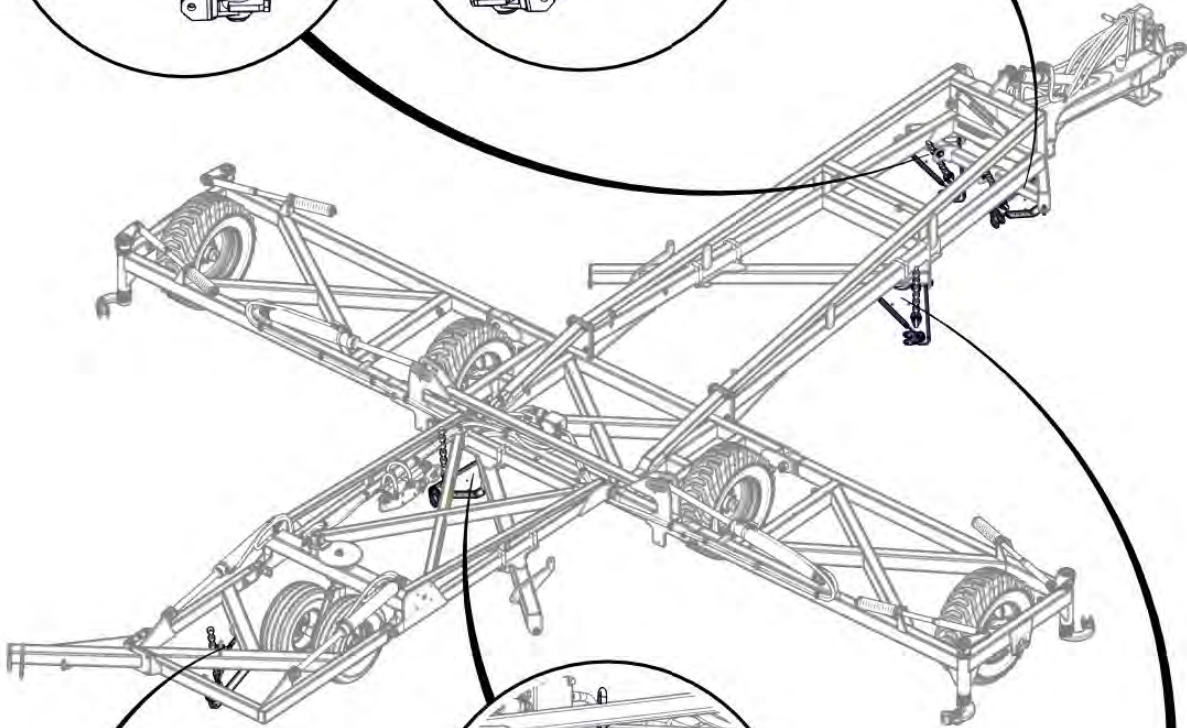
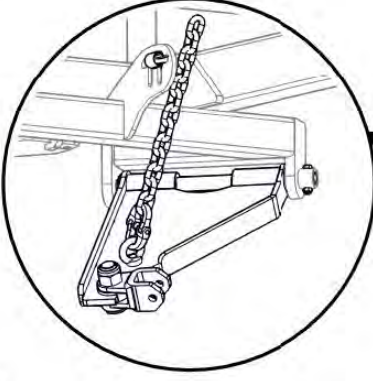
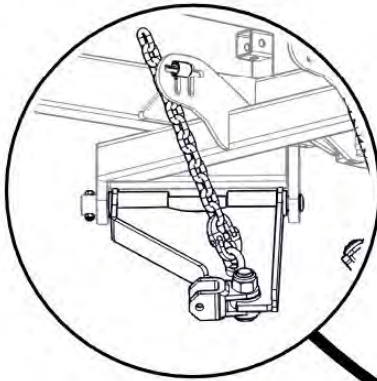

0802-FK-0810-29-30A

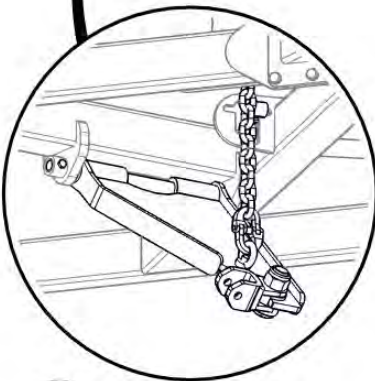

0802-FK-0810-10EA

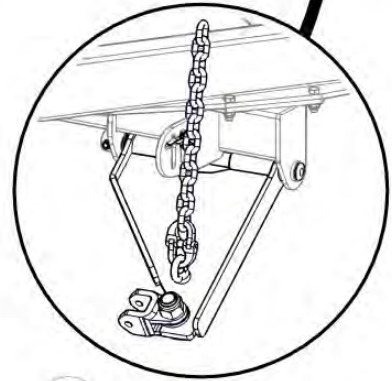

0802-FK-0810-28-30A



| Item No. | Description                             | Number         | Qty |
|----------|---|----------------|-----|
| 1        | Extended Chain Mount Plate              | 0810-69        | 1   |
| 2        | Forged Clevis 21mm Bolt Hole            | 0801-FC21      | 1   |
| 3        | Height Adjusting Chain Assembly 13 Link | 0801-20MCA     | 1   |
| 4        | Stainless Steel Wear Bush               | 1501-365033-SS | 1   |
| 5        | Chain Mount Pivot Pin                   | 0801-10-51     | 1   |
| 6        | Washer High Tensile 1 3/8"              | 0232-HT13-8    | 1   |
| 7        | Height Adjustor Retaining Clip          | 0801-KE014     | 1   |
| 8        | M36 x 105 grade 8.8 zp Bolt             | 0211-36105     | 1   |
| 9        | Nyloc Nut M36                           | 0221-NYL36     | 1   |
| 10       | M12 x 80 Class 8.8 ZP Bolt              | 0211-1280      | 1   |
| 11       | Nyloc Nut M12                           | 0221-NYL12     | 1   |

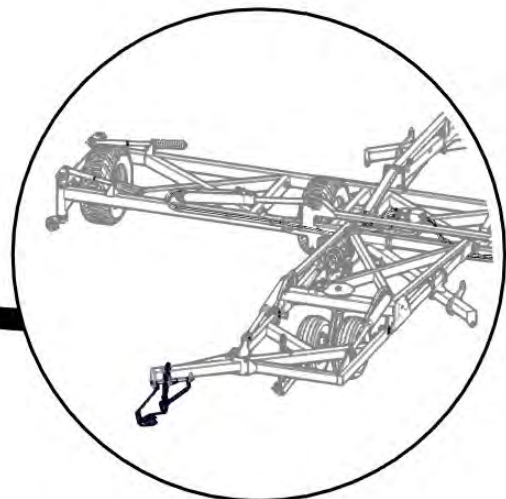
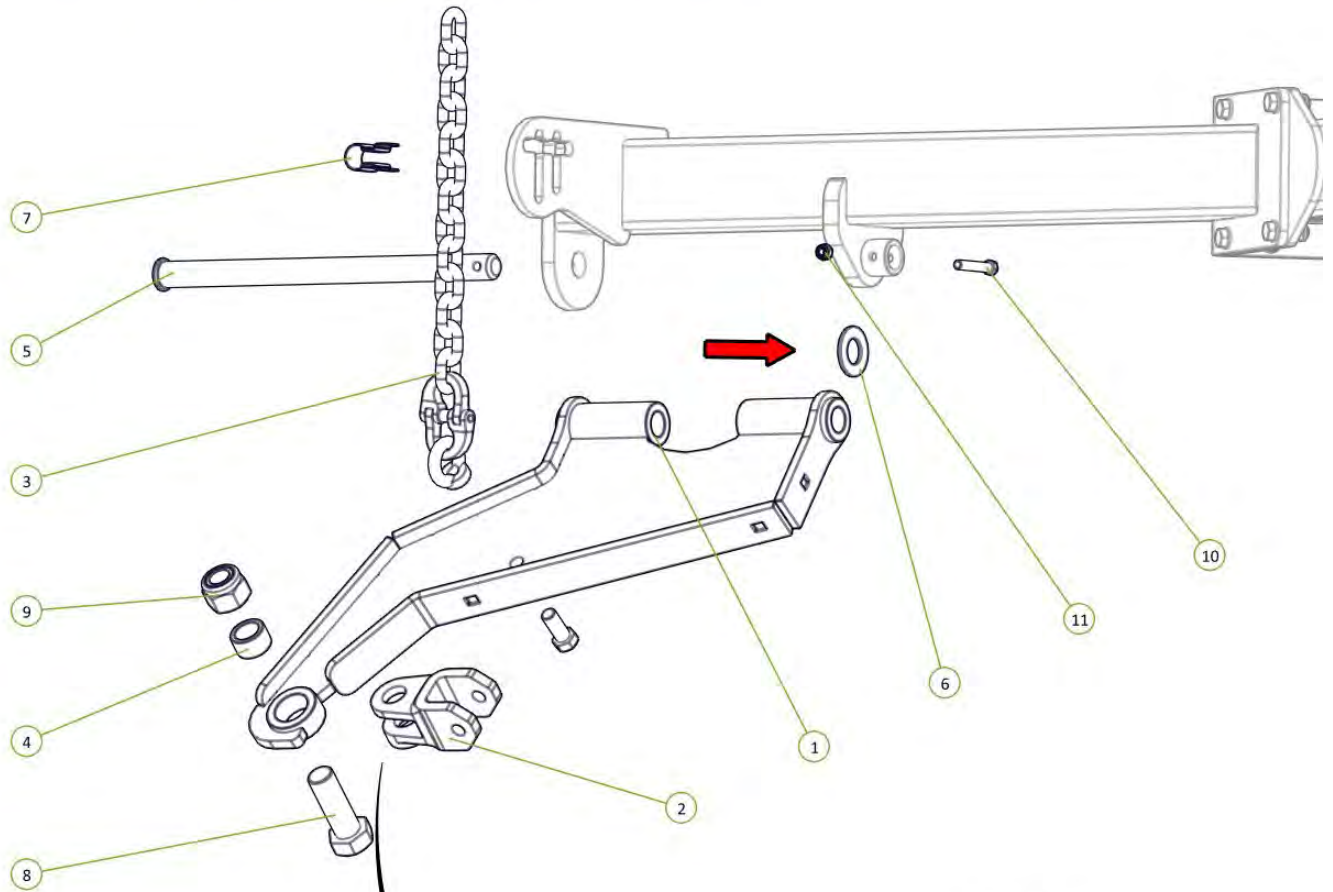



| Item No. | Description                             | Number       | Qty |
|----------|---|--------------|-----|
| 1        | Tension Box                             | 0810-57      | 1   |
| 2        | Module Tension Rod Assembly             | 0810-105A    | 1   |
| 3        | 20mm Compression Spring                 | 0801-XK9261S | 1   |
| 4        | Rigid Spring Locator                    | 0801-10-S2L  | 1   |
| 5        | Washer High Tensile 1 1/4"              | 0232-HT11-4  | 1   |
| 6        | Height Adjusting Chain Assembly 13 Link | 0801-20MCA   | 1   |

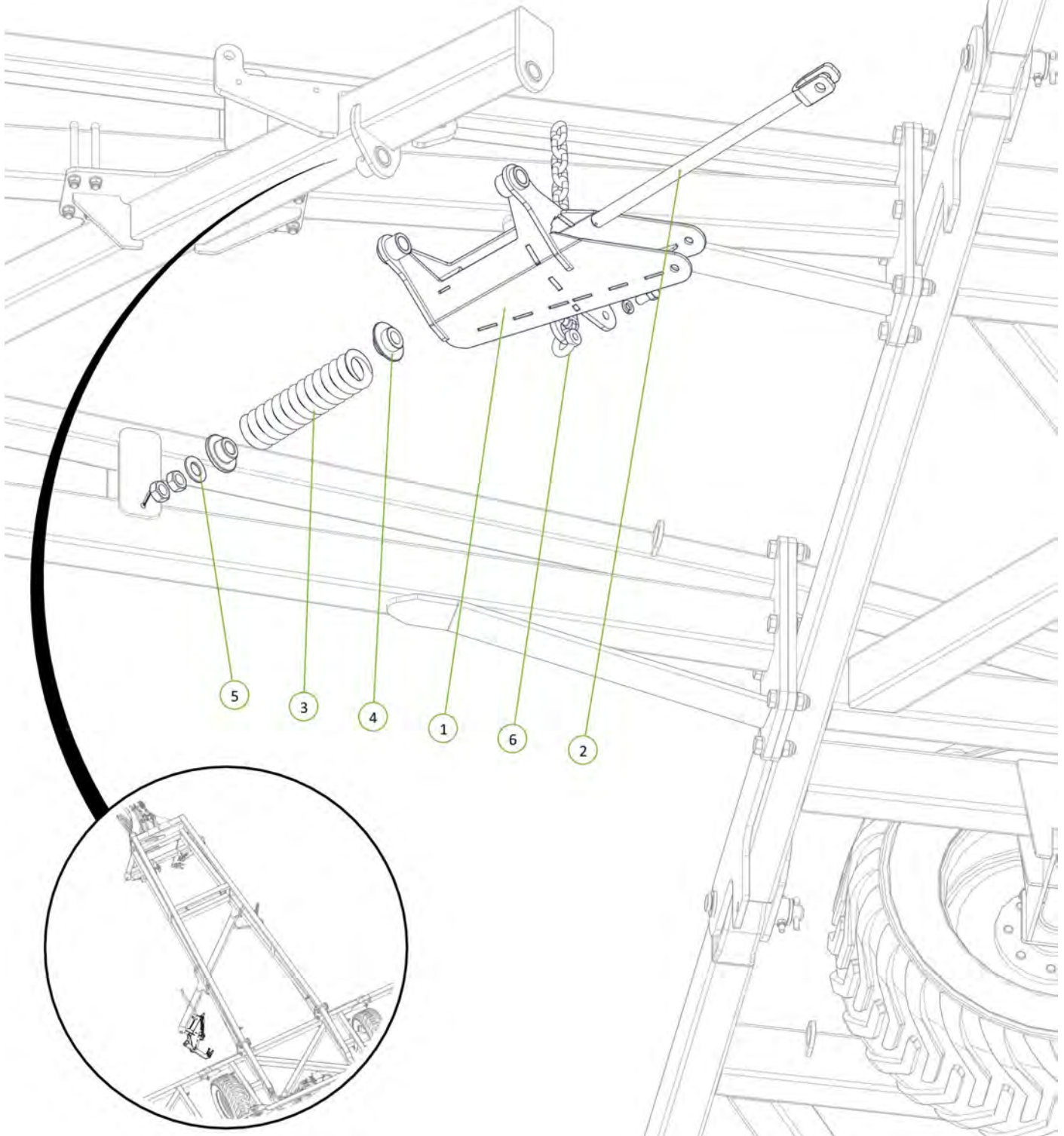

| Item No. | Description                  | Number         | Qty |
|----------|------------------------------|----------------|-----|
| 1        | Module Tension Arm No Clevis | 0810-104F      | 1   |
| 2        | 35 ID x 50mm DU Bush         | 0113-MB3550DU  | 2   |
| 3        | Module Pivot Arm Bush        | 0801-10-110    | 1   |
| 4        | M20 x 160 Class 8.8 ZP Bolt  | 0211-20160     | 1   |
| 5        | Forged Clevis 21mm Bolt Hole | 0801-FC21      | 1   |
| 6        | M36 x 105 grade 8.8 zp Bolt  | 0211-36105     | 1   |
| 7        | Stainless Steel Wear Bush    | 1501-365033-SS | 1   |
| 8        | Washer Flat M24              | 0231-F24       | 1   |
| 9        | Washer Flat M20              | 0231-F20       | 2   |
| 10       | Nyloc Nut M36                | 0221-NYL36     | 1   |
| 11       | Nyloc Nut M20                | 0221-NYL20     | 1   |

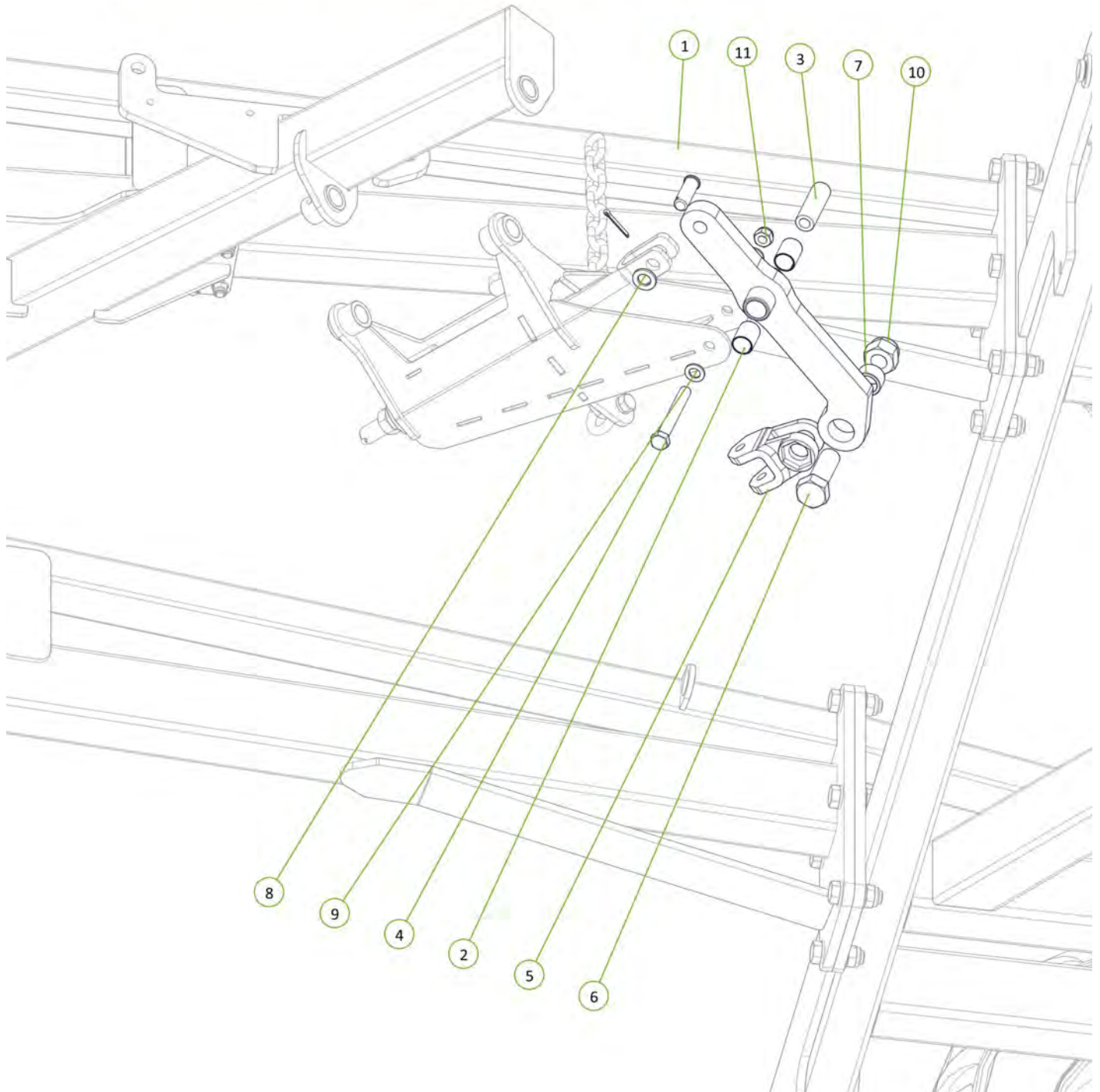



| Item No. | Description                | Number      | Qty |
|----------|----------------------------|-------------|-----|
| 1        | Chain Mount Pivot Pin      | 0801-10-51  | 1   |
| 2        | Washer High Tensile 1 3/8" | 0232-HT13-8 | 1   |
| 3        | M12 x 80 Class 8.8 ZP Bolt | 0211-1280   | 1   |
| 4        | Nyloc Nut M12              | 0221-NYL12  | 1   |

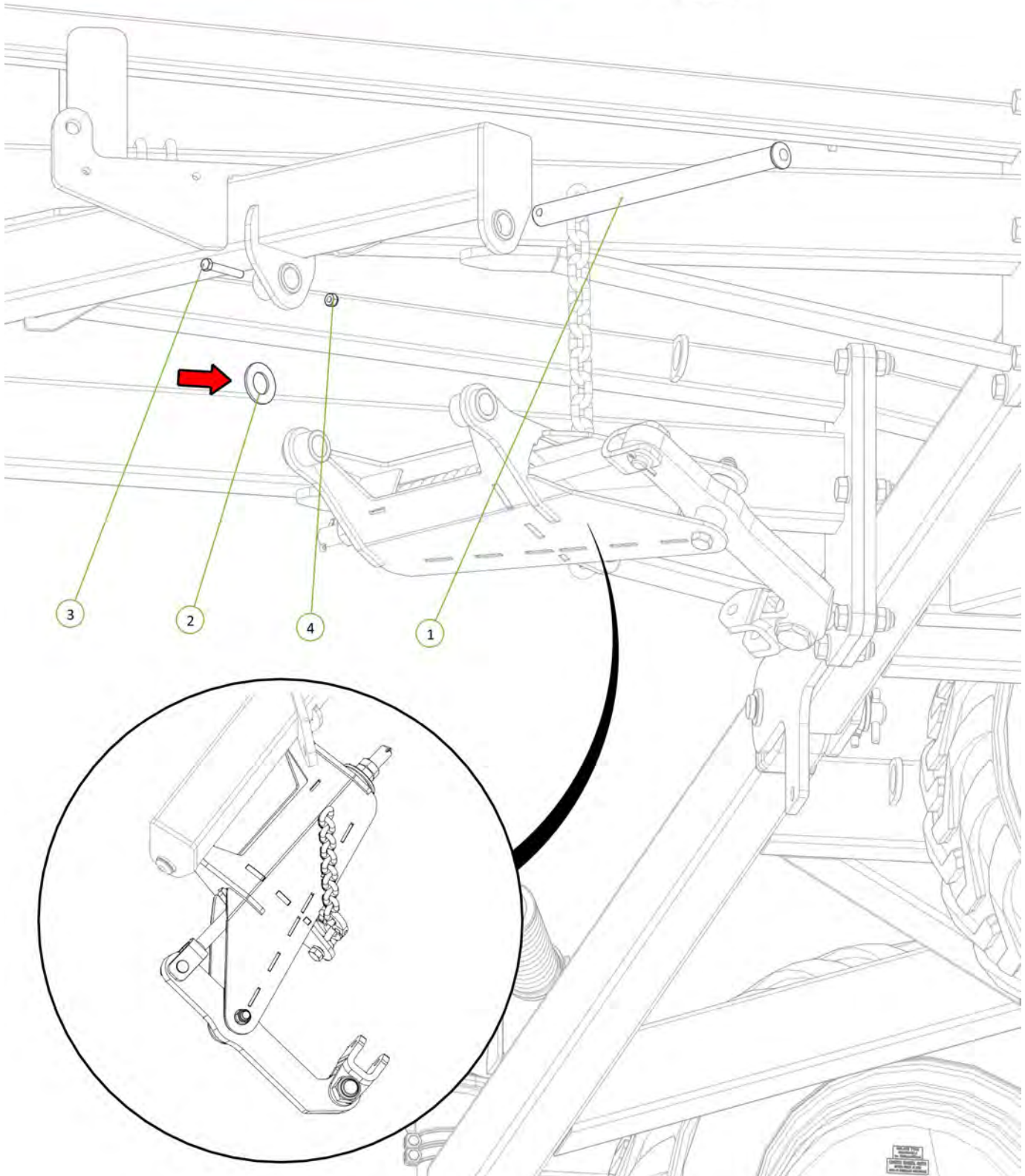



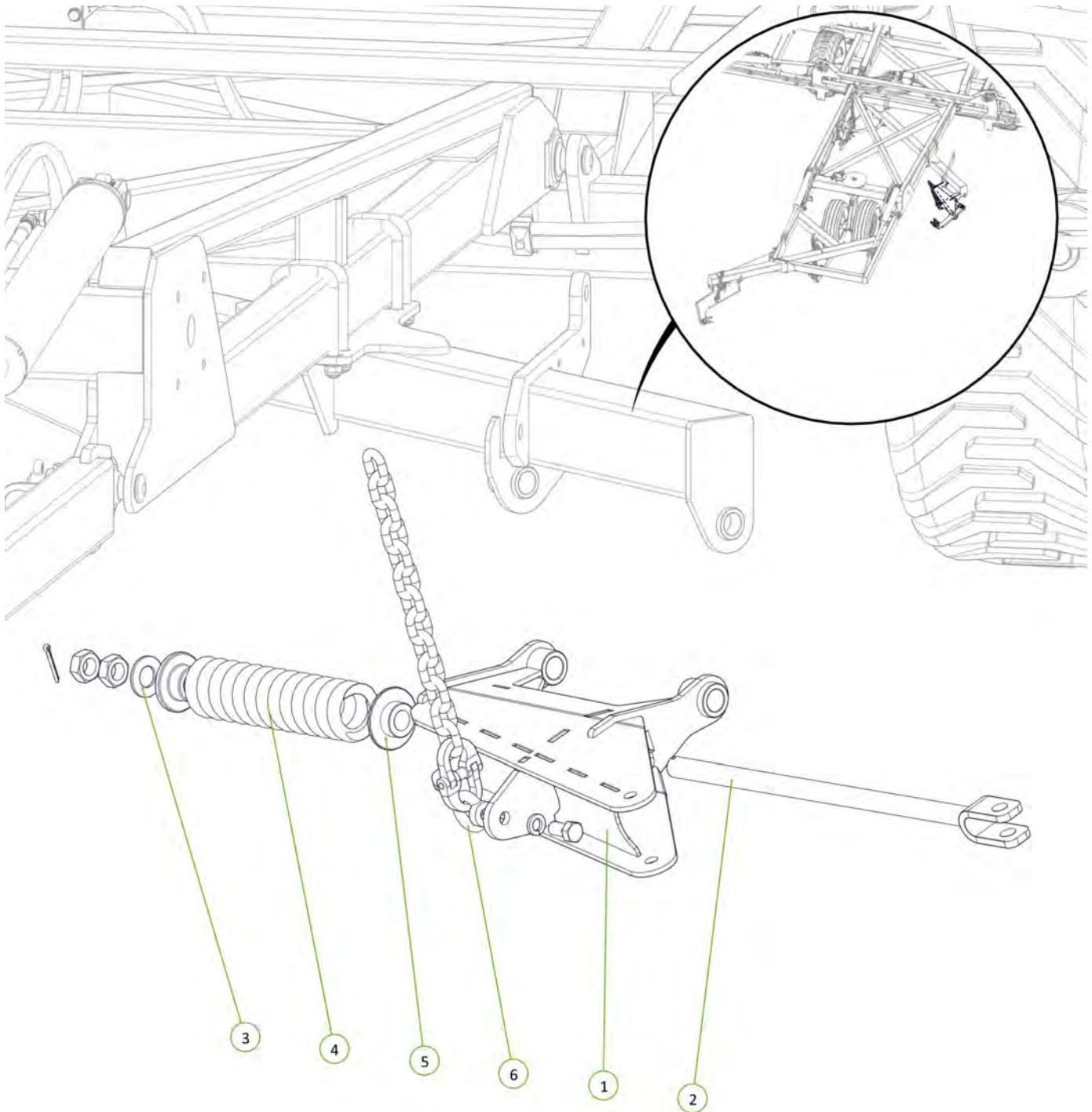

| Item No. | Description                             | Number       | Qty |
|----------|---|--------------|-----|
| 1        | Tension Box                             | 0810-57      | 1   |
| 2        | Module Tension Rod Assembly             | 0810-105A    | 1   |
| 3        | Washer High Tensile 1 1/4"              | 0232-HT11-4  | 1   |
| 4        | 20mm Compression Spring                 | 0801-XK9261S | 1   |
| 5        | Rigid Spring Locator                    | 0801-10-S2L  | 1   |
| 6        | Height Adjusting Chain Assembly 13 Link | 0801-20MCA   | 1   |



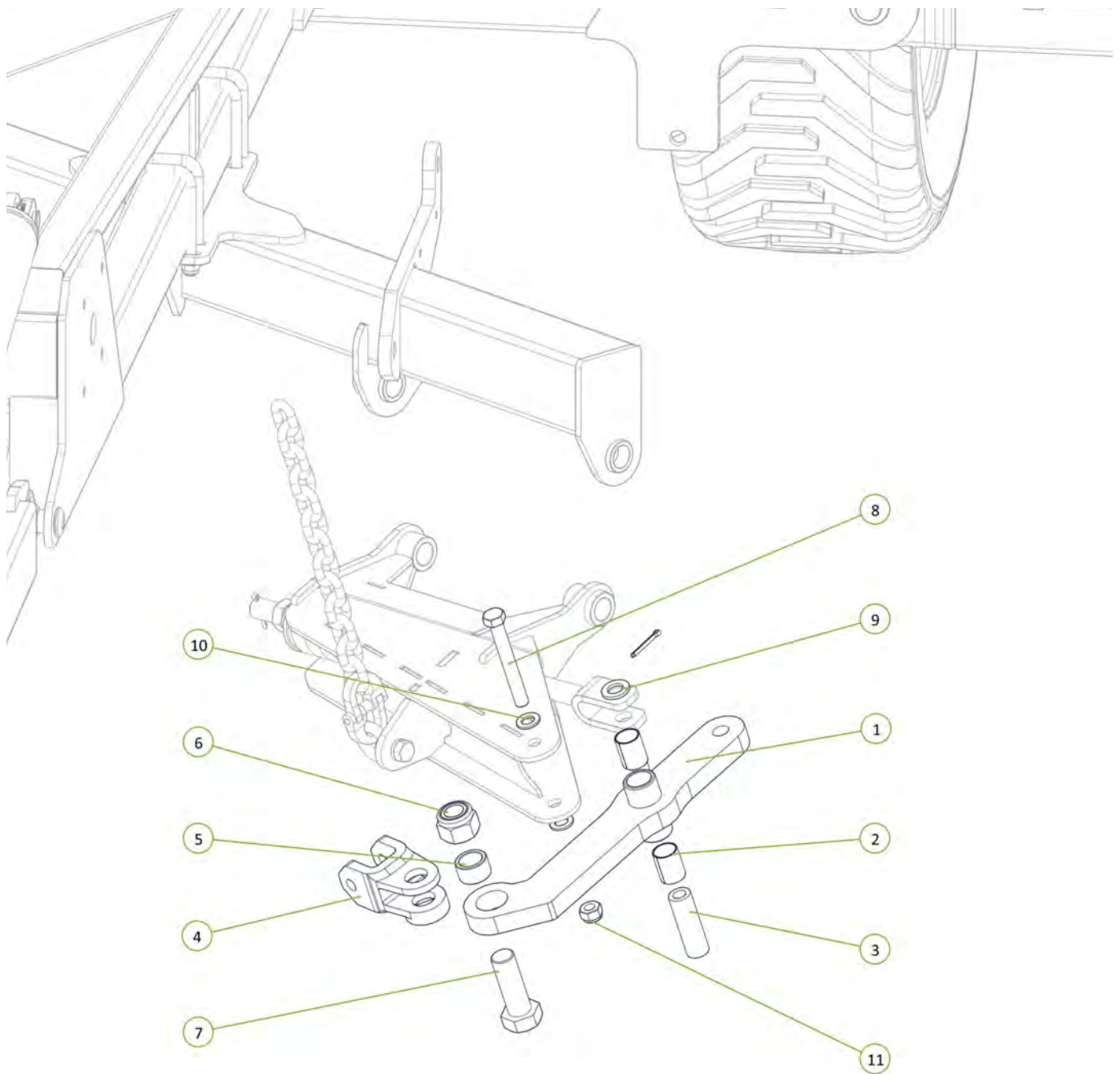

| Item No. | Description                  | Number         | Qty |
|----------|------------------------------|----------------|-----|
| 1        | Module Tension Arm No Clevis | 0810-104F      | 1   |
| 2        | 35 ID x 50mm DU Bush         | 0113-MB3550DU  | 2   |
| 3        | Module Pivot Arm Bush        | 0801-10-110    | 1   |
| 4        | Forged Clevis 21mm Bolt Hole | 0801-FC21      | 1   |
| 5        | Stainless Steel Wear Bush    | 1501-365033-SS | 1   |
| 6        | Nyloc Nut M36                | 0221-NYL36     | 1   |
| 7        | M36 x 105 grade 8.8 zp Bolt  | 0211-36105     | 1   |
| 8        | M20 x 160 Class 8.8 ZP Bolt  | 0211-20160     | 1   |
| 9        | Washer Flat M24              | 0232-F24       | 1   |
| 10       | Washer Flat M20              | 0231-F20       | 2   |
| 11       | Nyloc Nut M20                | 0221-NYL20     | 1   |



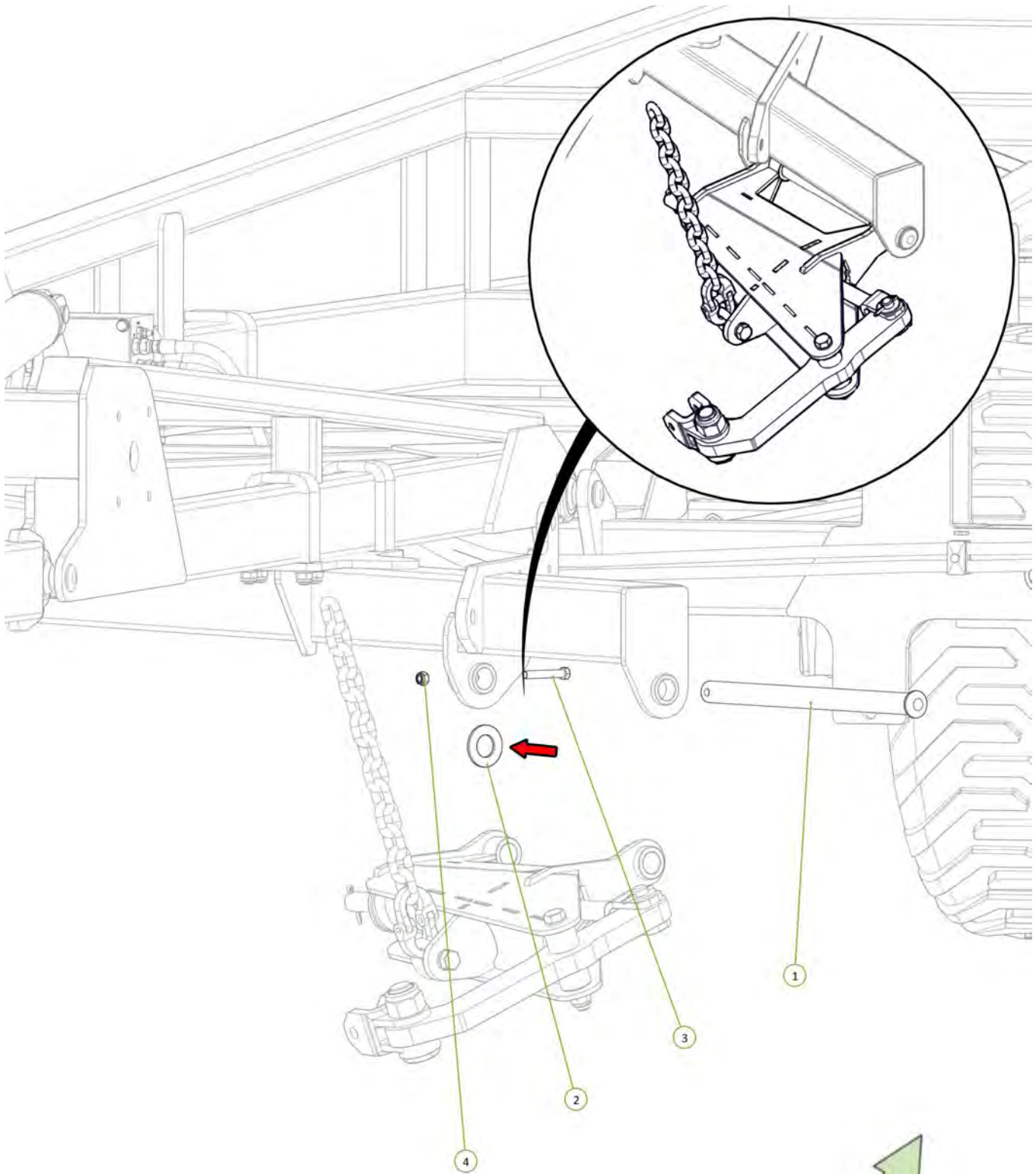

| Item No. | Description                | Number      | Qty |
|----------|----------------------------|-------------|-----|
| 1        | Chain Mount Pivot Pin      | 0801-10-51  | 1   |
| 2        | Washer High Tensile 1 3/8" | 0232-HT13-8 | 1   |
| 3        | M12 x 80 Class 8.8 ZP Bolt | 0211-1280   | 1   |
| 4        | Nyloc Nut M12              | 0221-NYL12  | 1   |





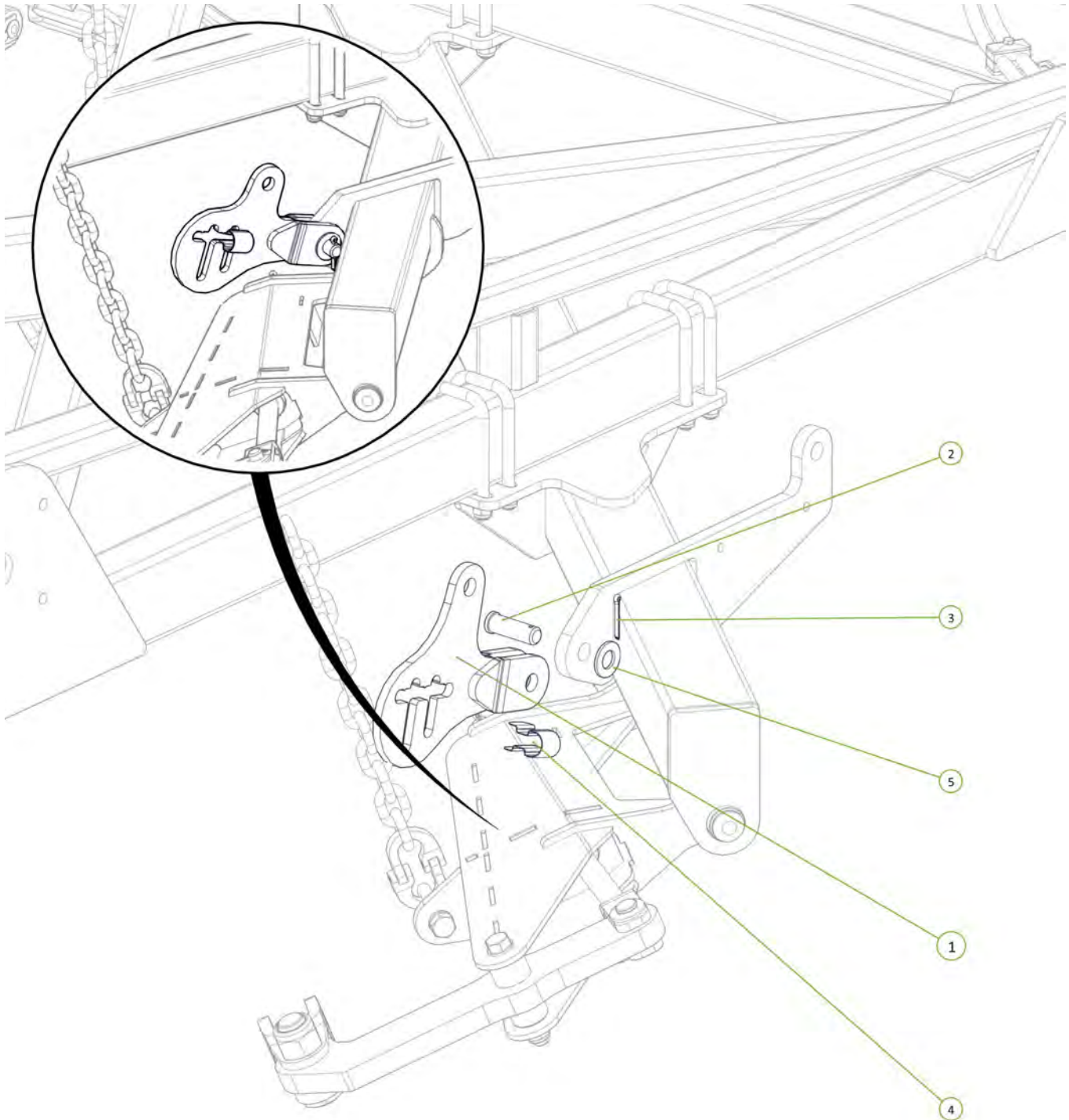

| Item No. | Description                    | Number        | Qty |
|----------|--------------------------------|---------------|-----|
| 1        | Reduced Lift Arm               | 0810-84       | 1   |
| 2        | Clevis Pin 25mm x 75mm         | 0801-KE0307-1 | 1   |
| 3        | Cotter Pin M5 x 50             | 0261-PINC550  | 1   |
| 4        | Height Adjuster Retaining Clip | 0801-KE014    | 1   |
| 5        | Washer Flat 1"                 | 0232-F1       | 1   |



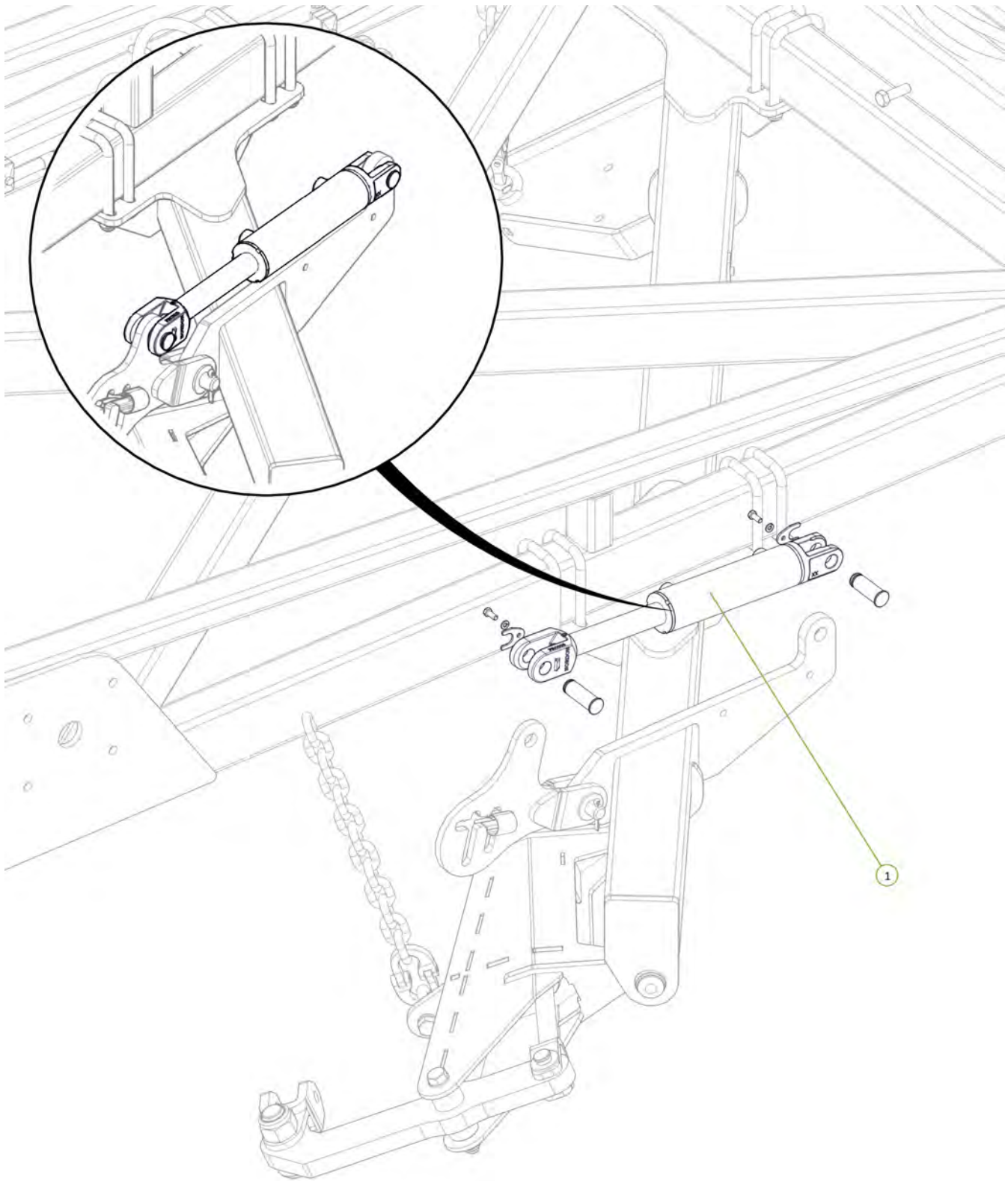

| Item No. | Description                                       | Number     | Qty |
|----------|---|------------|-----|
| 1        | 2.5" Bore x 6" Stroke 1.5" Rod Side Port Cylinder | 0311-256SP | 1   |



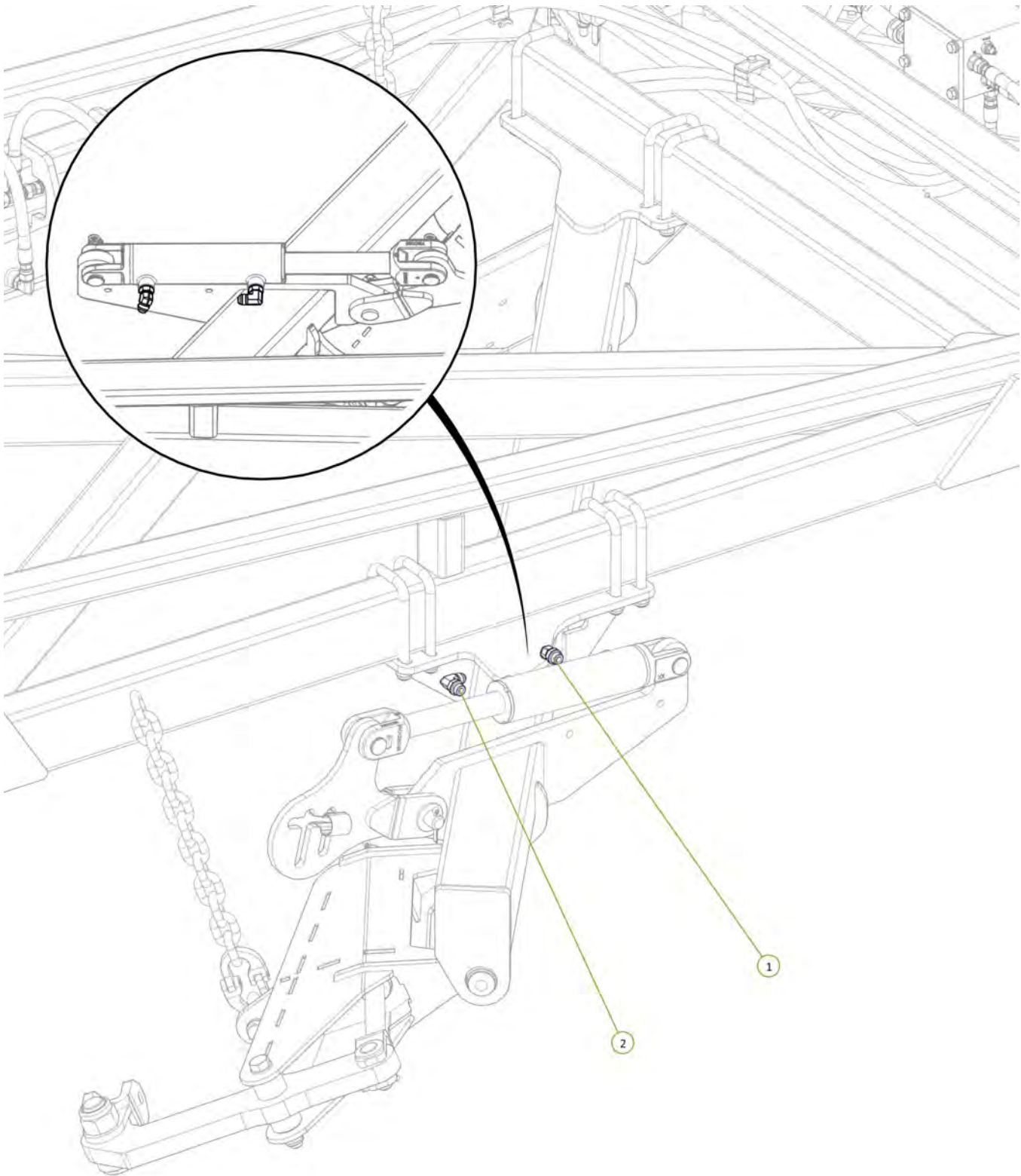

| Item No. | Description                                 | Number | Qty |
|----------|---|--------|-----|
| 1        | 3/4" JIC Male 3/4" UN O Ring Male 45° Elbow | 0323-S | 7   |
| 2        | 3/4" JIC Male 3/4" UN O Ring Male 90° Elbow | 0323-S | 7   |





| Item No. | Description                                   | Number   | Qty |
|----------|---|----------|-----|
| 1        | Valve RME Port to Right Rear Module Rear Port | PH30S-15 | 1   |
| 2        | Valve RMR Port to Right Rear Module Rod Port  | PH30S-16 | 1   |

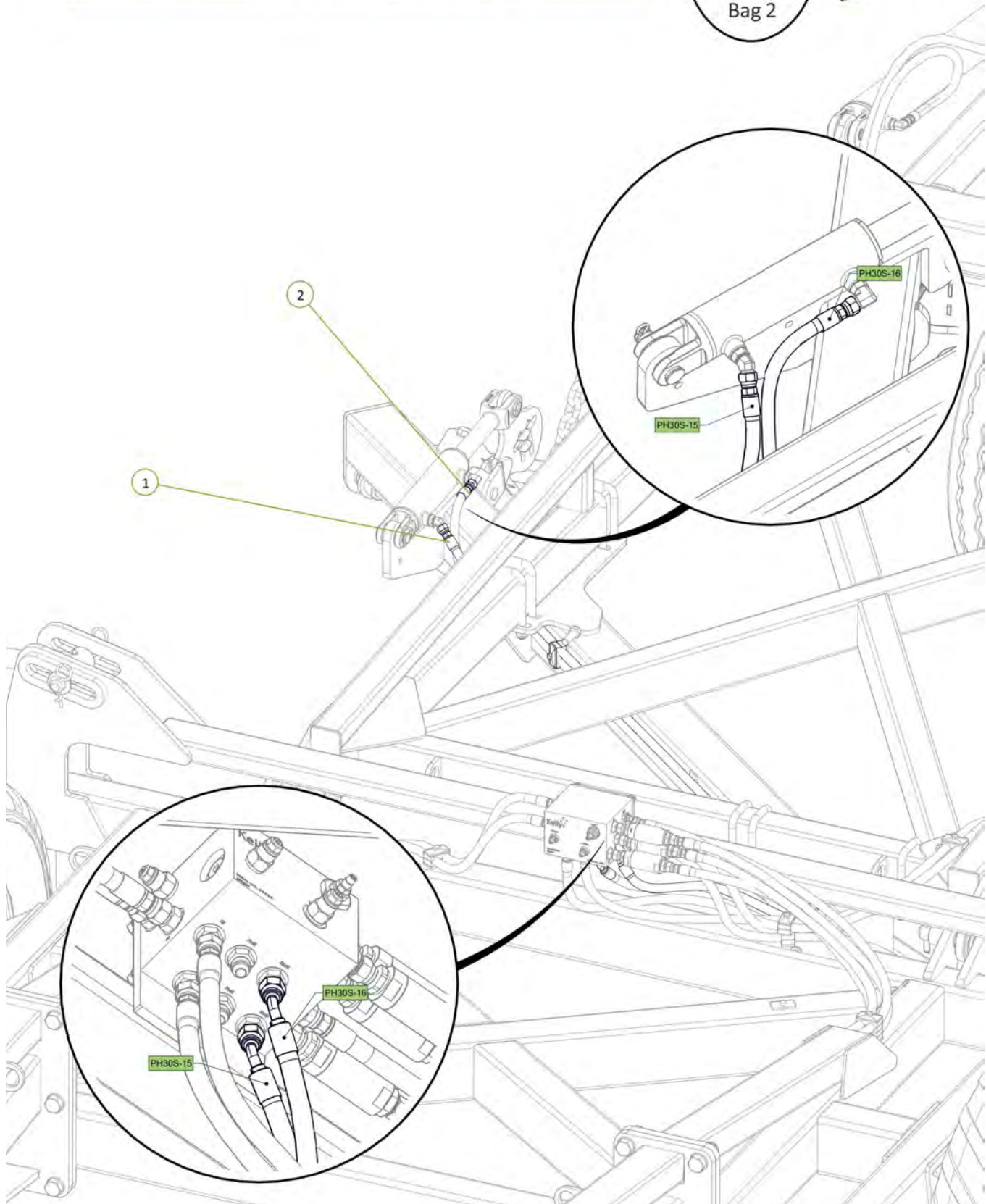

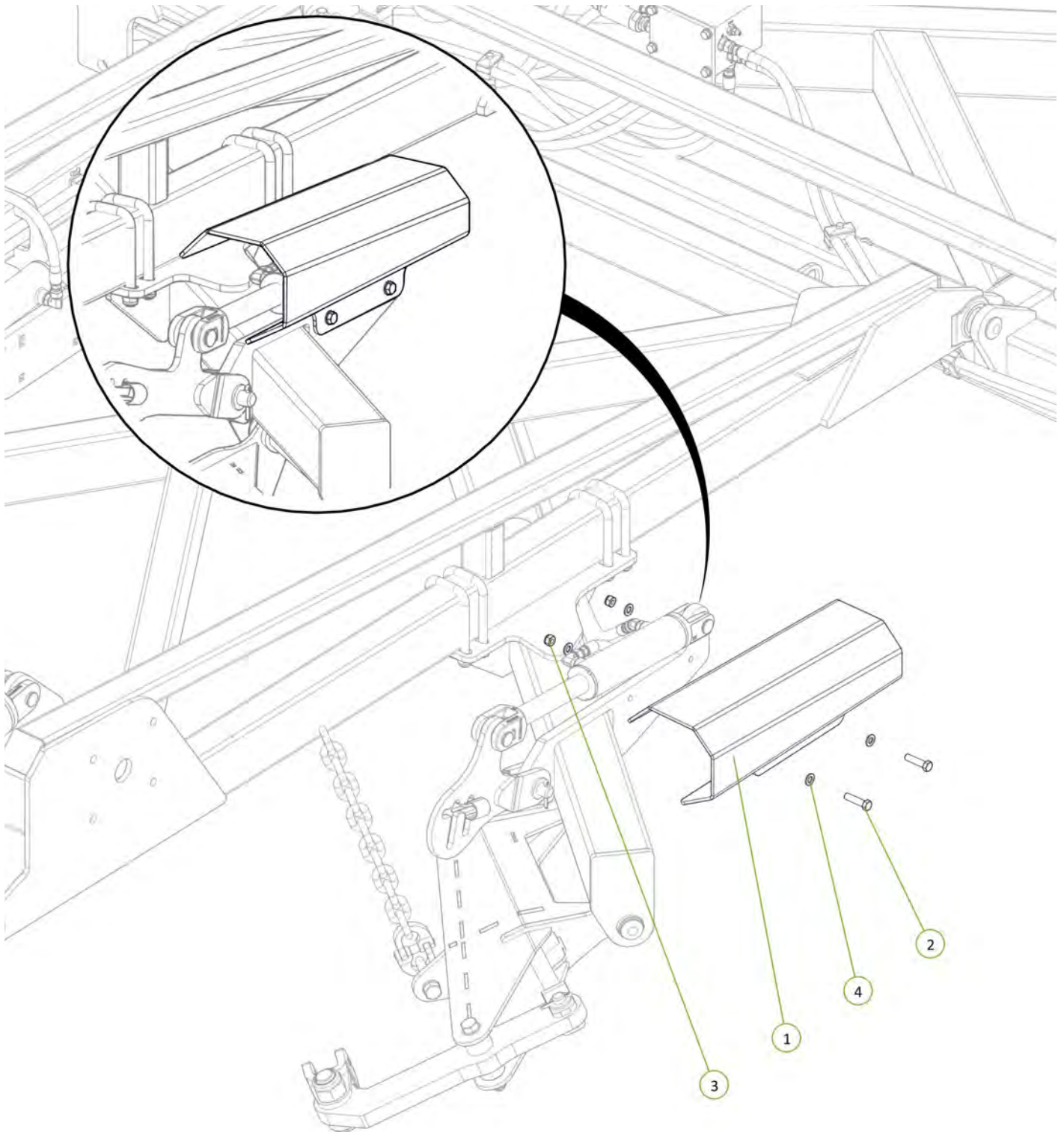

| Item No. | Description                | Number     | Qty |
|----------|----------------------------|------------|-----|
| 1        | Module Cylinder Guard      | 0800-167.3 | 1   |
| 2        | M12 x 50 grade 8.8 ZP Bolt | 0211-1250  | 2   |
| 3        | Nyloc Nut M12              | 0221-NYL12 | 2   |
| 4        | Washer Flat M12            | 0231-F12   | 4   |





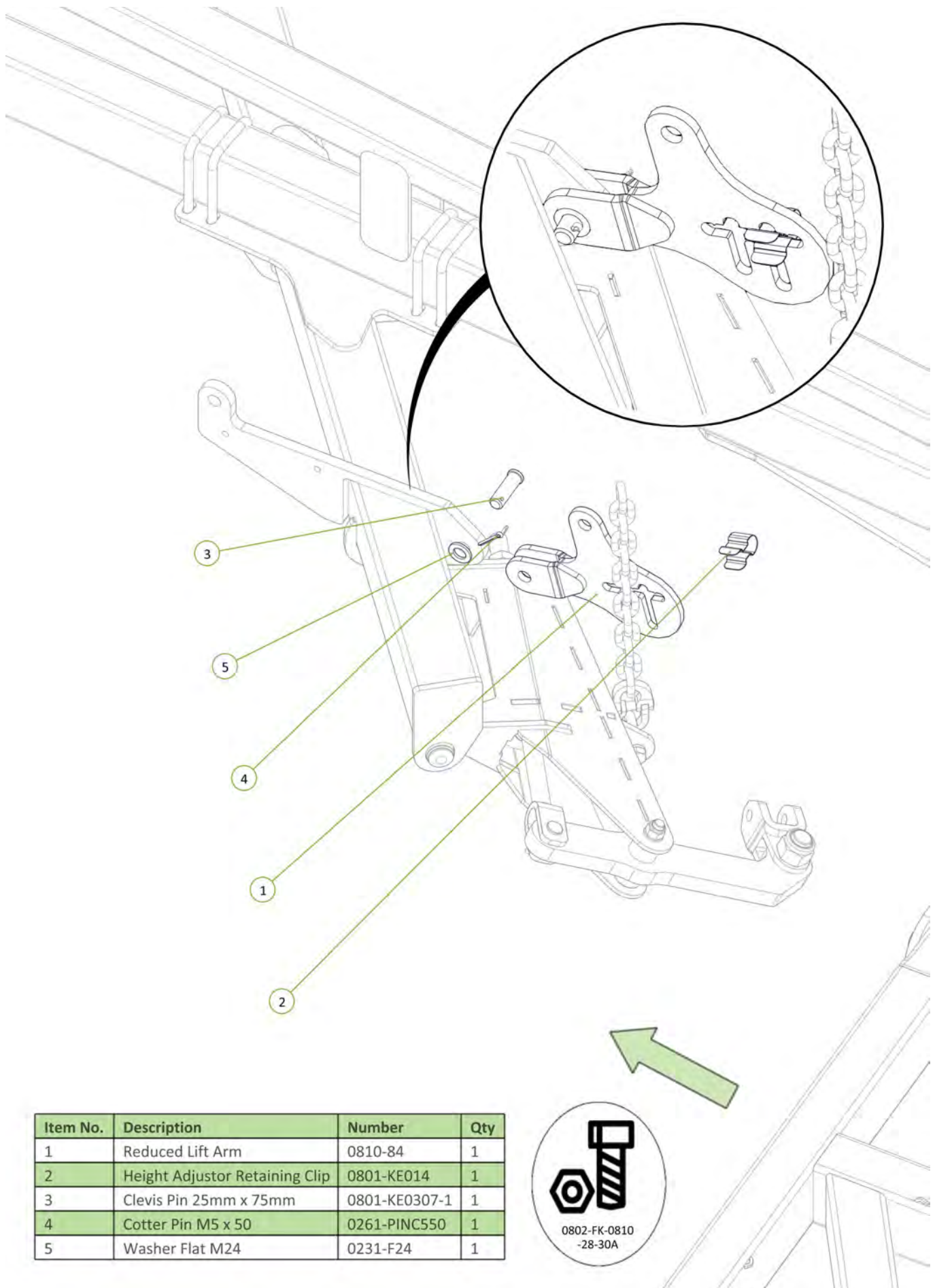



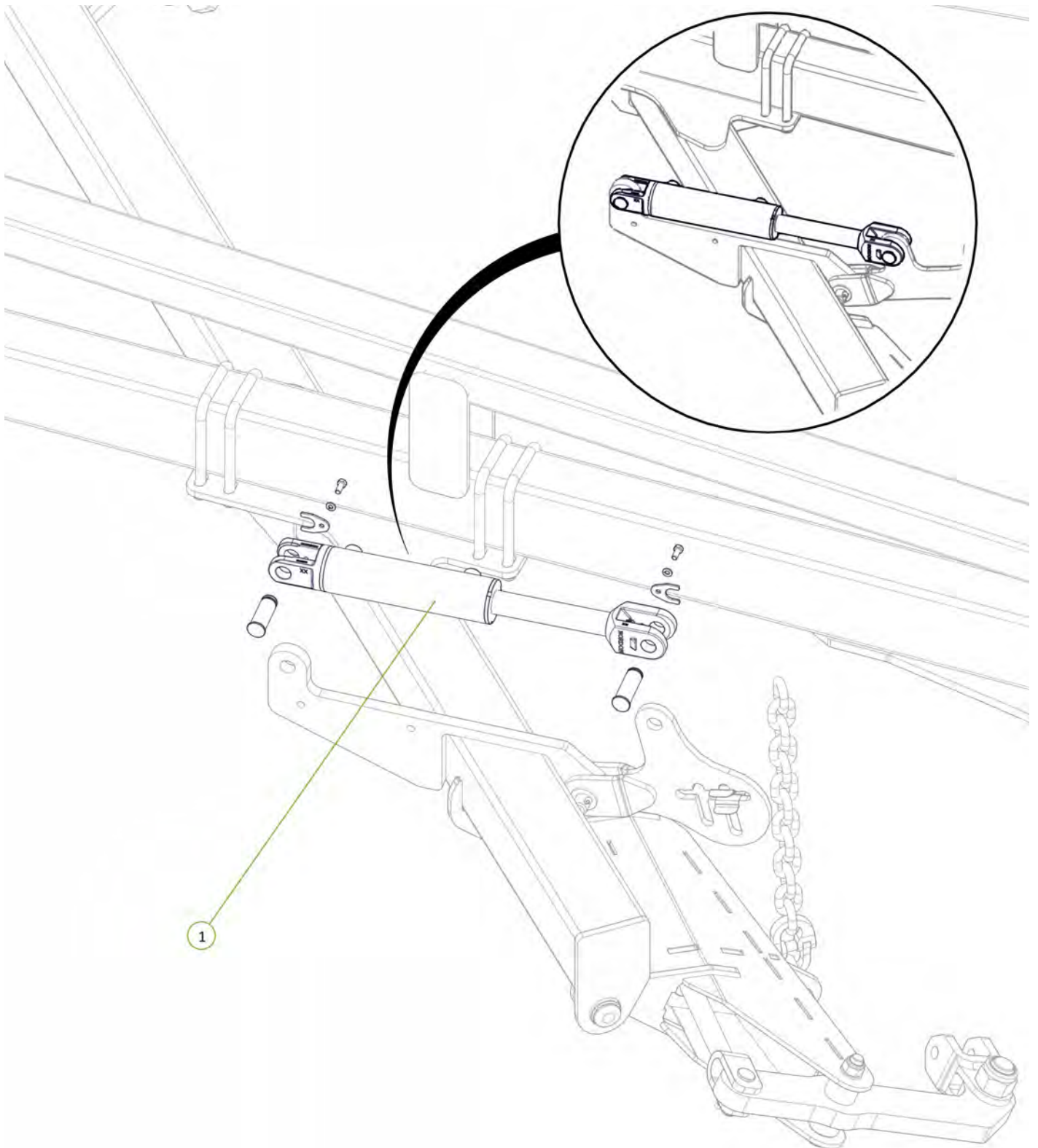

| Item No. | Description                                       | Number     | Qty |
|----------|---|------------|-----|
| 1        | 2.5" Bore x 6" Stroke 1.5" Rod Side Port Cylinder | 0311-256SP | 1   |

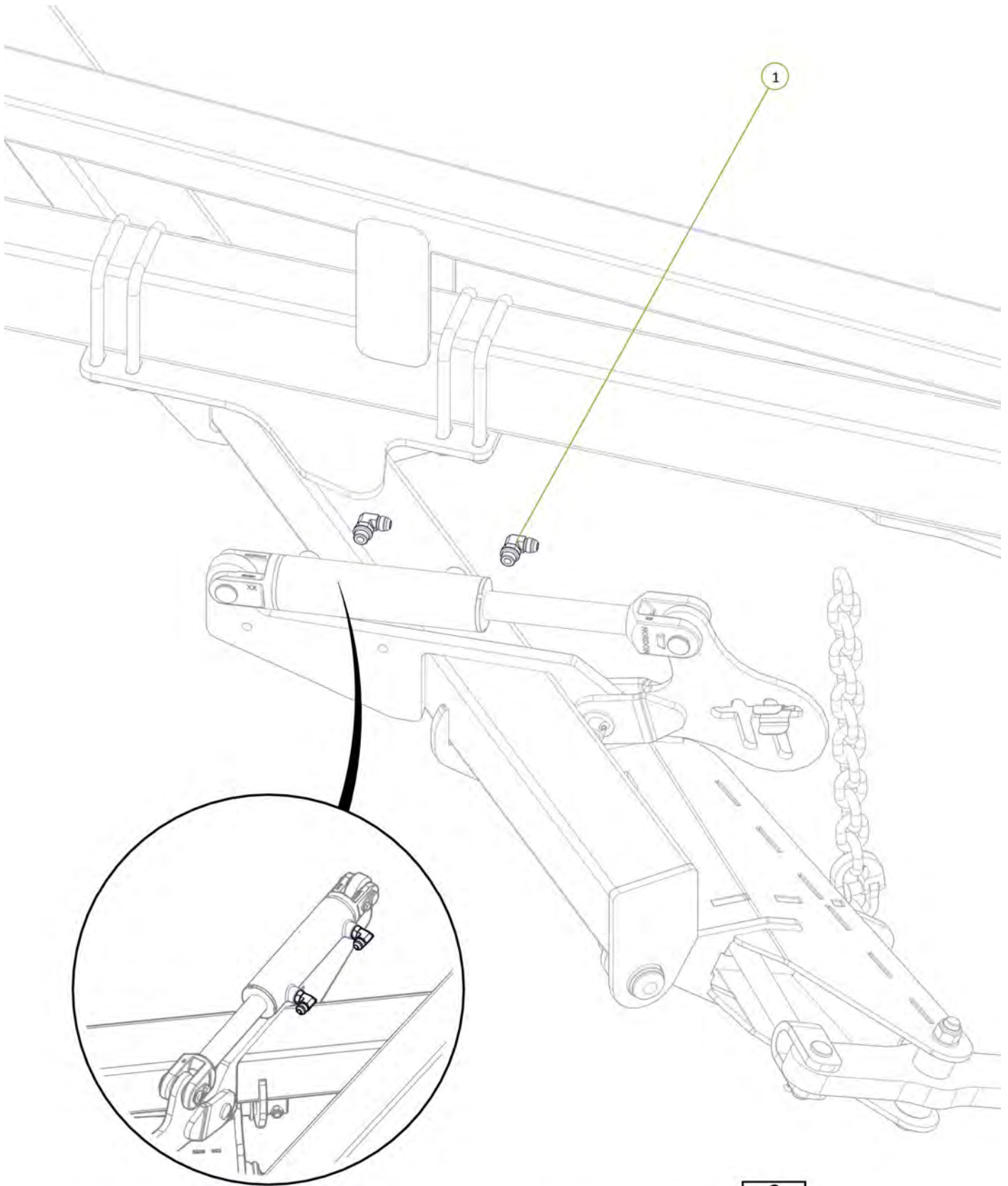

| Item No. | Description                                 | Number        | Qty |
|----------|---|---------------|-----|
| 1        | 3/4" JIC Male 3/4" UN O Ring Male 90° Elbow | 0323-S91-1212 | 2   |



| Item No. | Description                             | Number   | Qty |
|----------|---|----------|-----|
| 1        | Front Module EXT Port to Valve FME Port | PH30S-03 | 1   |
| 2        | Front Module Rod Port to Valve FMR Port | PH30S-04 | 1   |

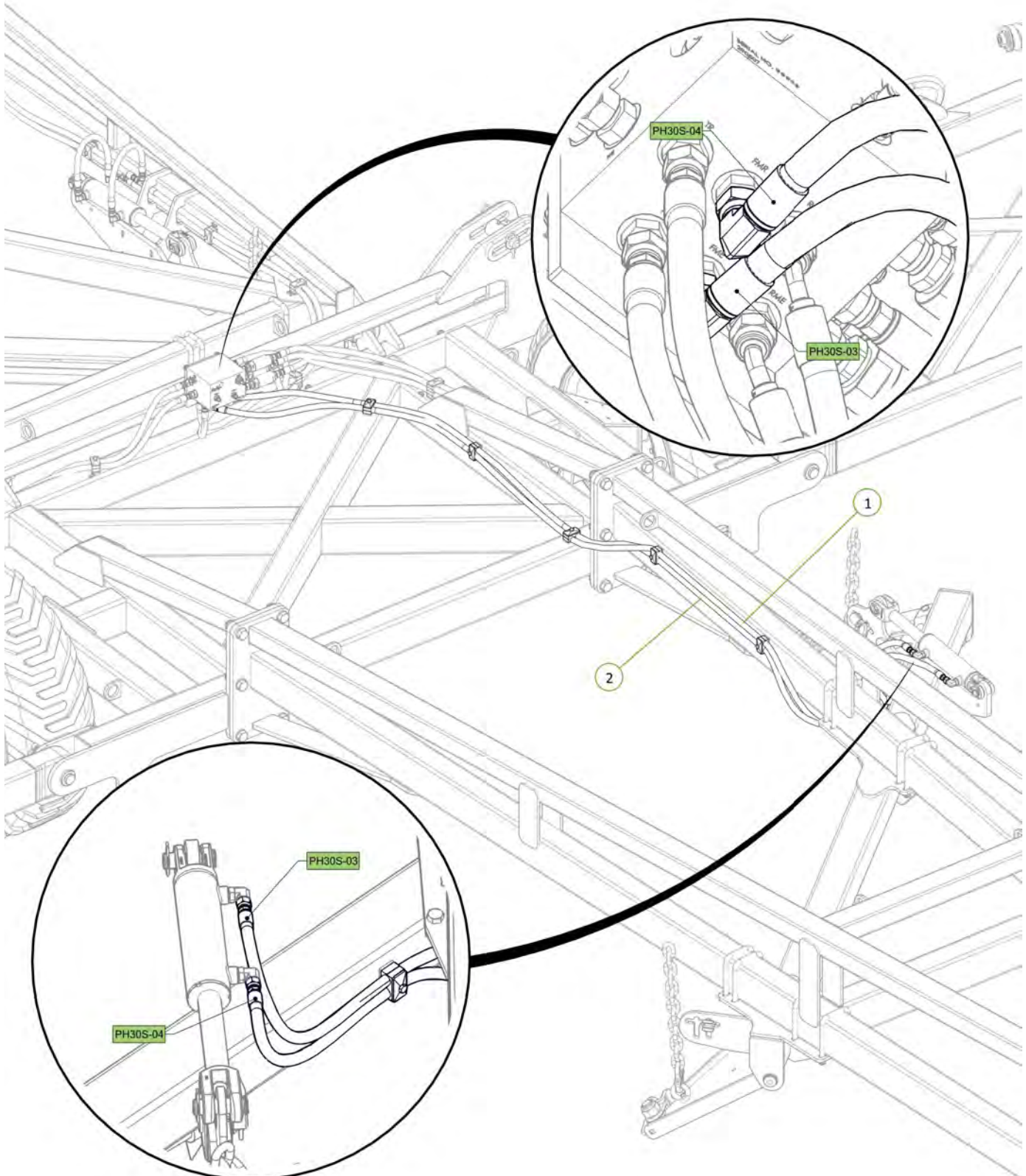



| Item No. | Description                      | Number        | Qty |
|----------|----------------------------------|---------------|-----|
| 1        | 30' Chain Carrier Beam           | 0810-17-30    | 1   |
| 2        | Chain Carrier Mount Plate        | 0800-139.1    | 2   |
| 3        | U-Bolt M16 x 114 Deep x 106 Wide | 0271-16112104 | 4   |
| 4        | U-Bolt M16 x 162 Deep x 129 Wide | 0271-16160127 | 4   |
| 5        | Washer Flat M16                  | 0231-F16      | 16  |
| 6        | Nyloc Nut M16                    | 0221-NYL16    | 16  |

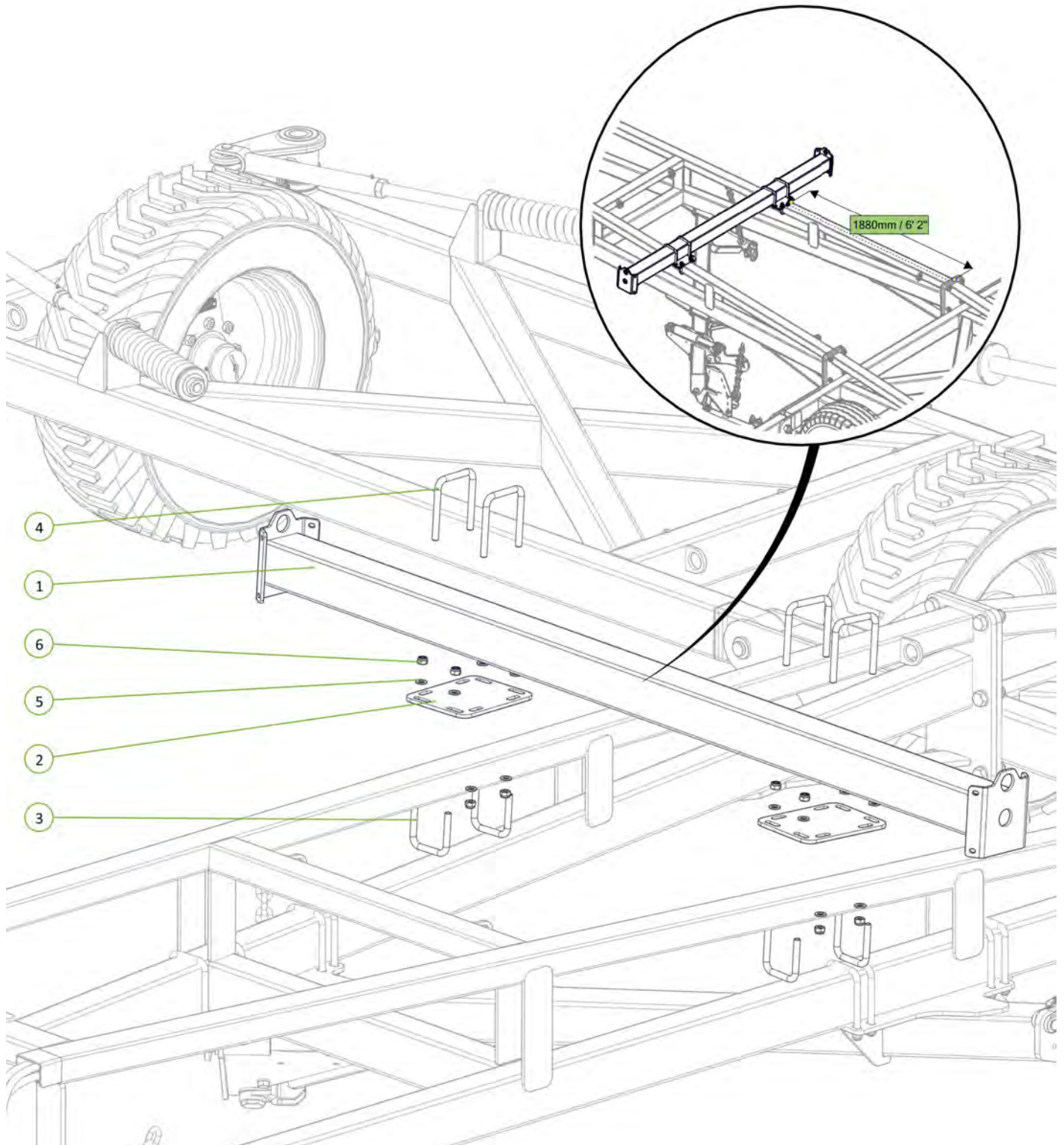
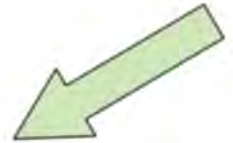

| Item No. | Description                        | Number      | Qty |
|----------|------------------------------------|-------------|-----|
| 1        | Extended Chain Carrier Bolt on End | 0810-17LE   | 2   |
| 2        | M12 x 40 Coach Head Bolt           | 0215-CH1240 | 8   |
| 3        | Nyloc Nut M12                      | 0221-NYL12  | 8   |
| 4        | Washer Flat M12                    | 0231-F12    | 8   |

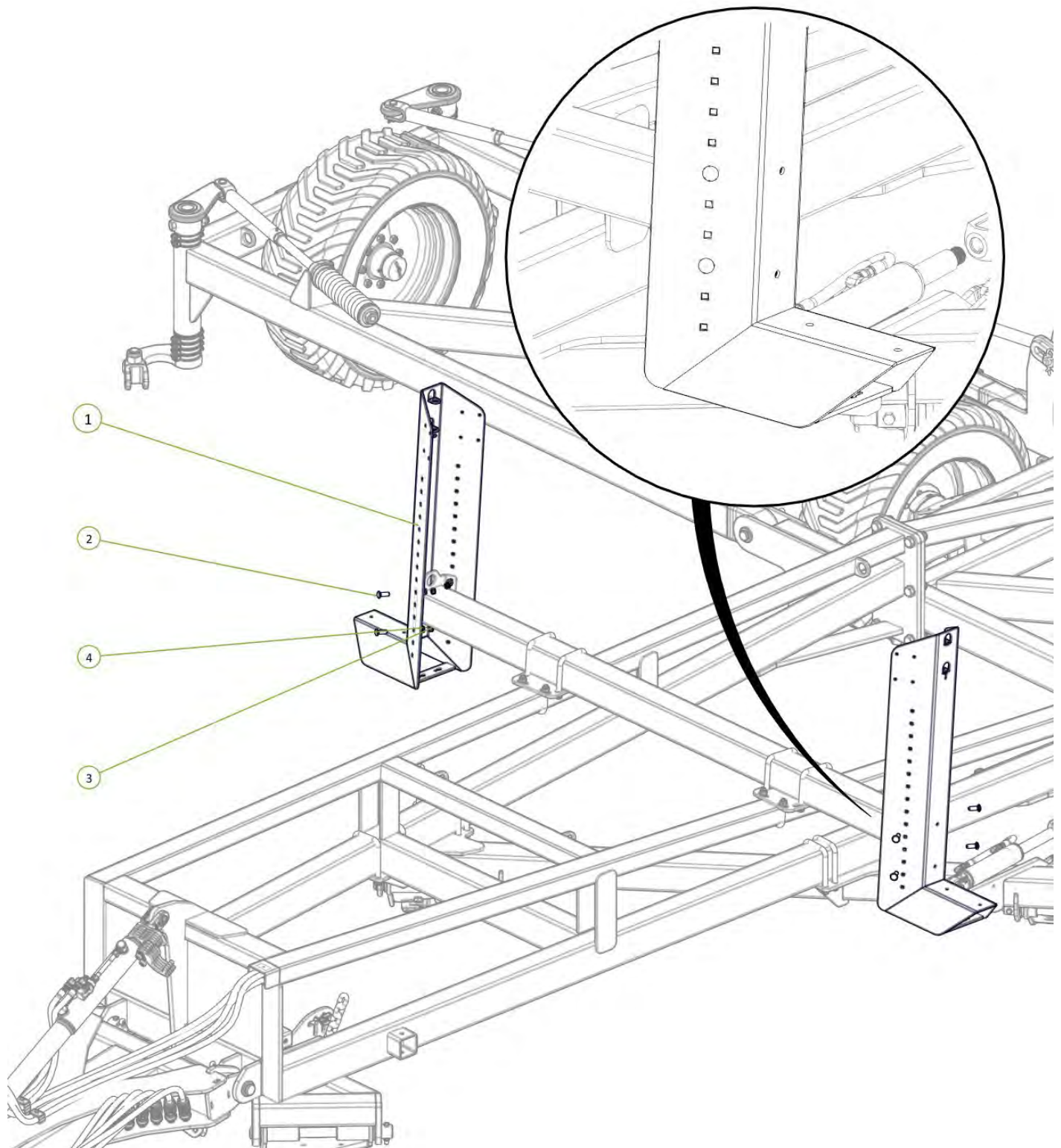



| Item No. | Description                | Number     | Qty |
|----------|----------------------------|------------|-----|
| 1        | 30' & 40' Outrigger        | 0810-40    | 2   |
| 2        | M16 x 55 grade 8.8 zp Bolt | 0211-1655  | 8   |
| 3        | Washer Flat M16            | 0231-F16   | 16  |
| 4        | Nyloc Nut M16              | 0221-NYL16 | 8   |

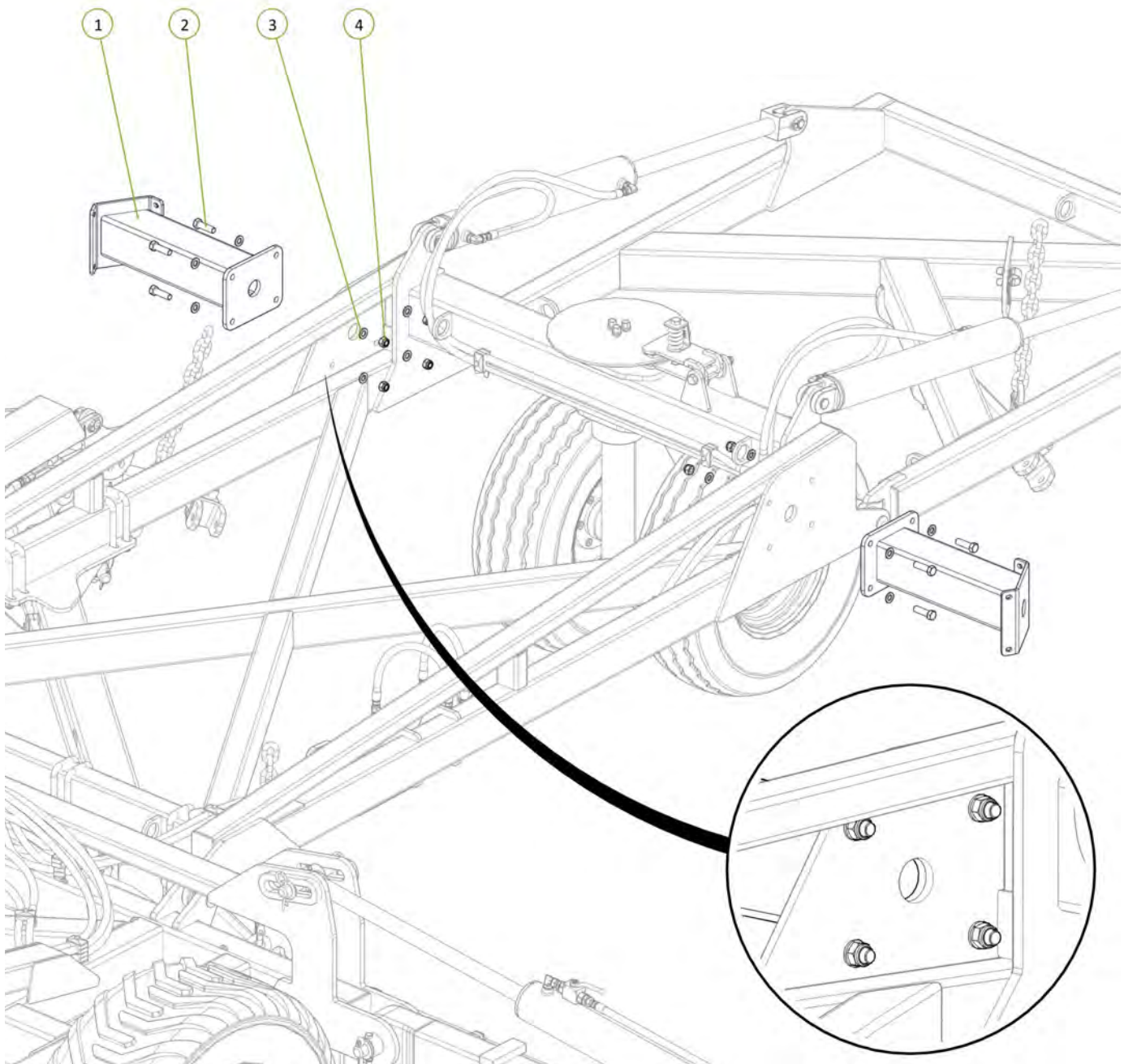



| Item No. | Description                        | Number      | Qty |
|----------|------------------------------------|-------------|-----|
| 1        | Extended Chain Carrier Bolt on End | 0810-17LE   | 2   |
| 2        | M12 x 40 Coach Head Bolt           | 0215-CH1240 | 8   |
| 3        | Nyloc Nut M12                      | 0221-NYL12  | 8   |
| 4        | Washer Flat M12                    | 0231-F12    | 8   |

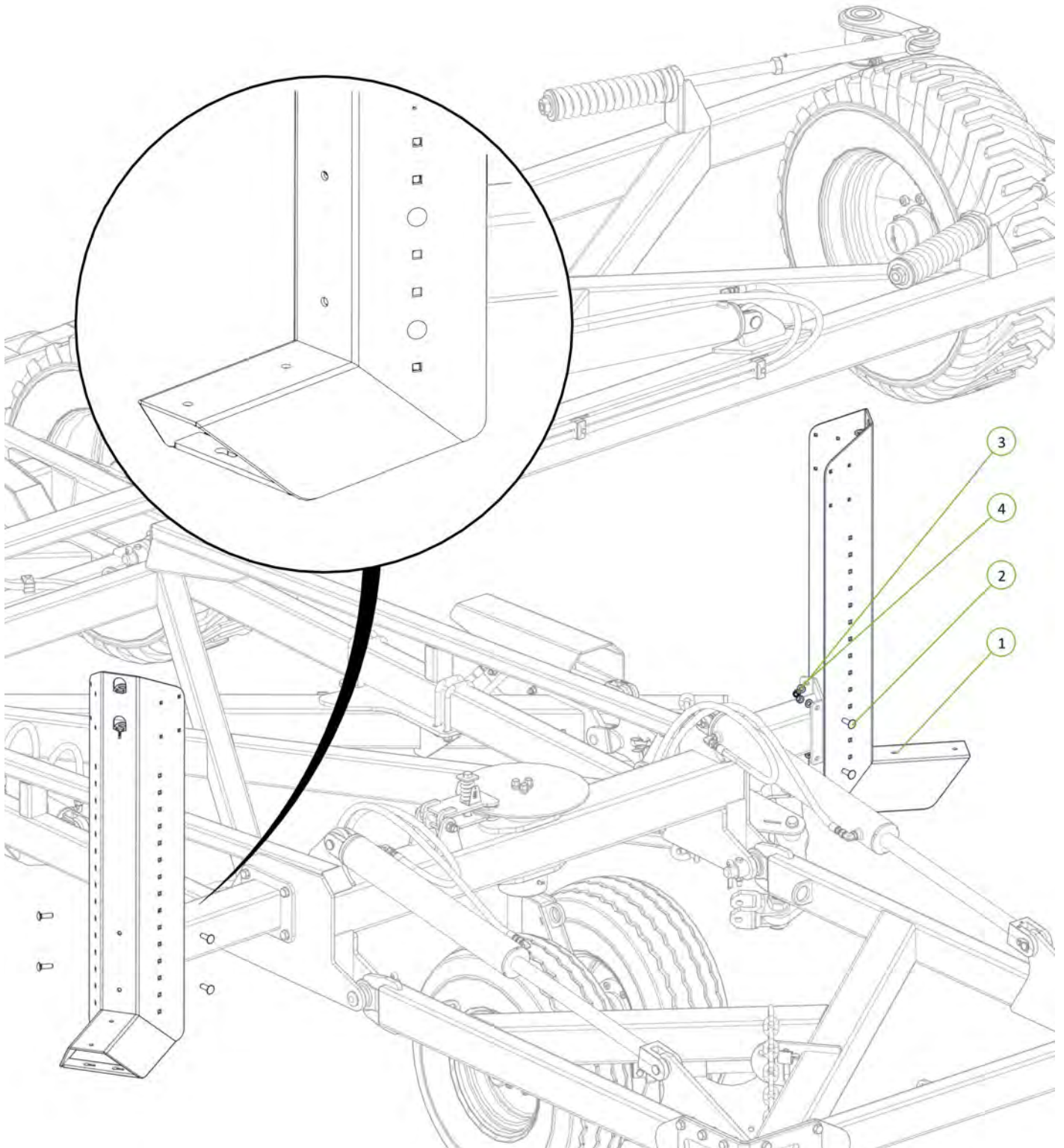

| Item No. | Description                | Number     | Qty |
|----------|----------------------------|------------|-----|
| 1        | 30' Chain Retainer Plate   | 0800-360   | 2   |
| 2        | M12 x 35 grade 8.8 ZP Bolt | 0211-1235  | 8   |
| 3        | Nyloc Nut M12              | 0221-NYL12 | 8   |
| 4        | Washer Flat M12            | 0231-F12   | 16  |

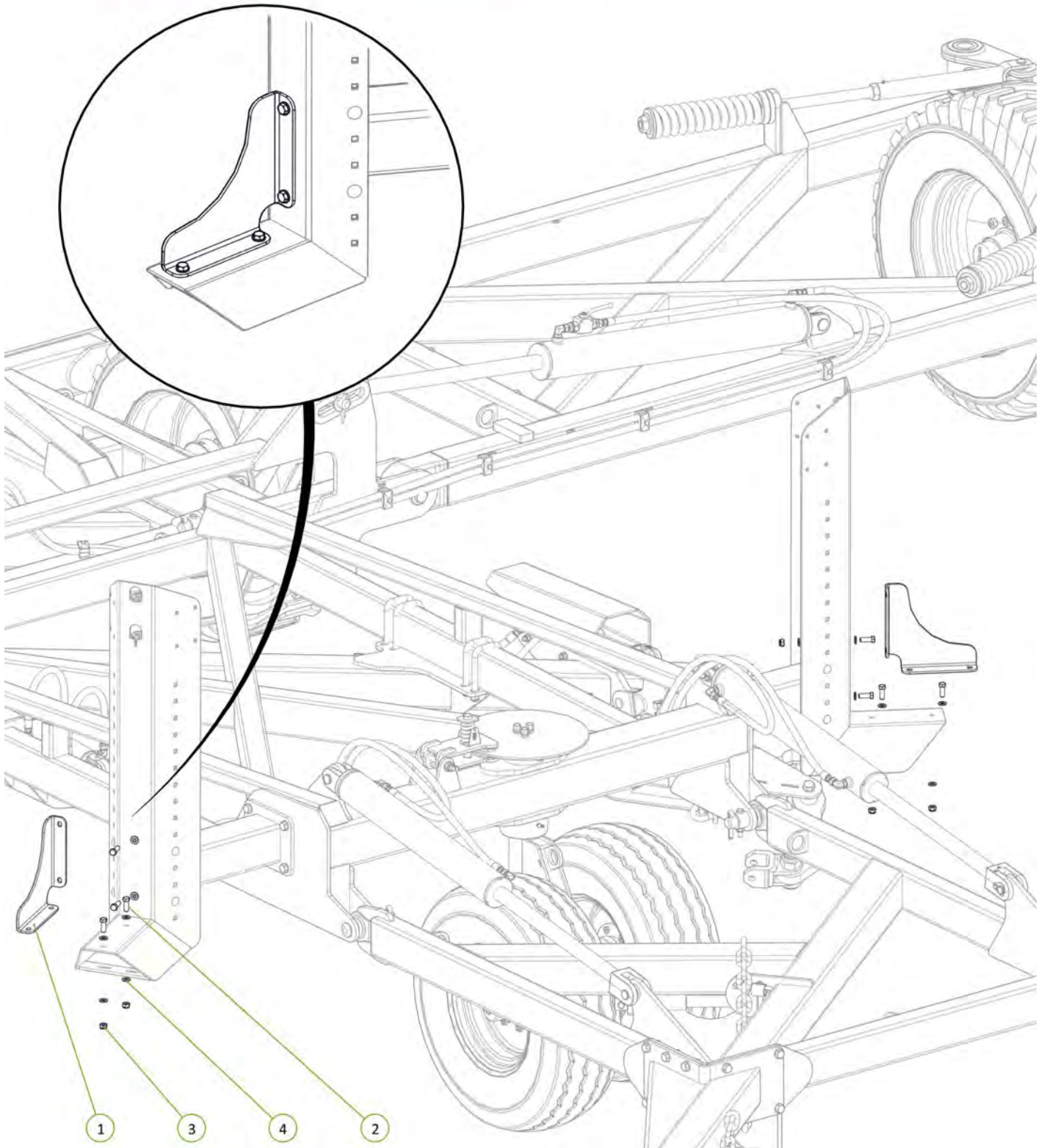



| Item No. | Description              | Number          | Qty |
|----------|--------------------------|-----------------|-----|
| 1        | Slow Moving Vehical Sign | 0801-FBSMVTUF   | 1   |
| 2        | SMV Sign Bracket         | 0800-195.1      | 1   |
| 3        | M6 x 20mm Trilobe Screw  | 0211-M620MZPHTF | 4   |

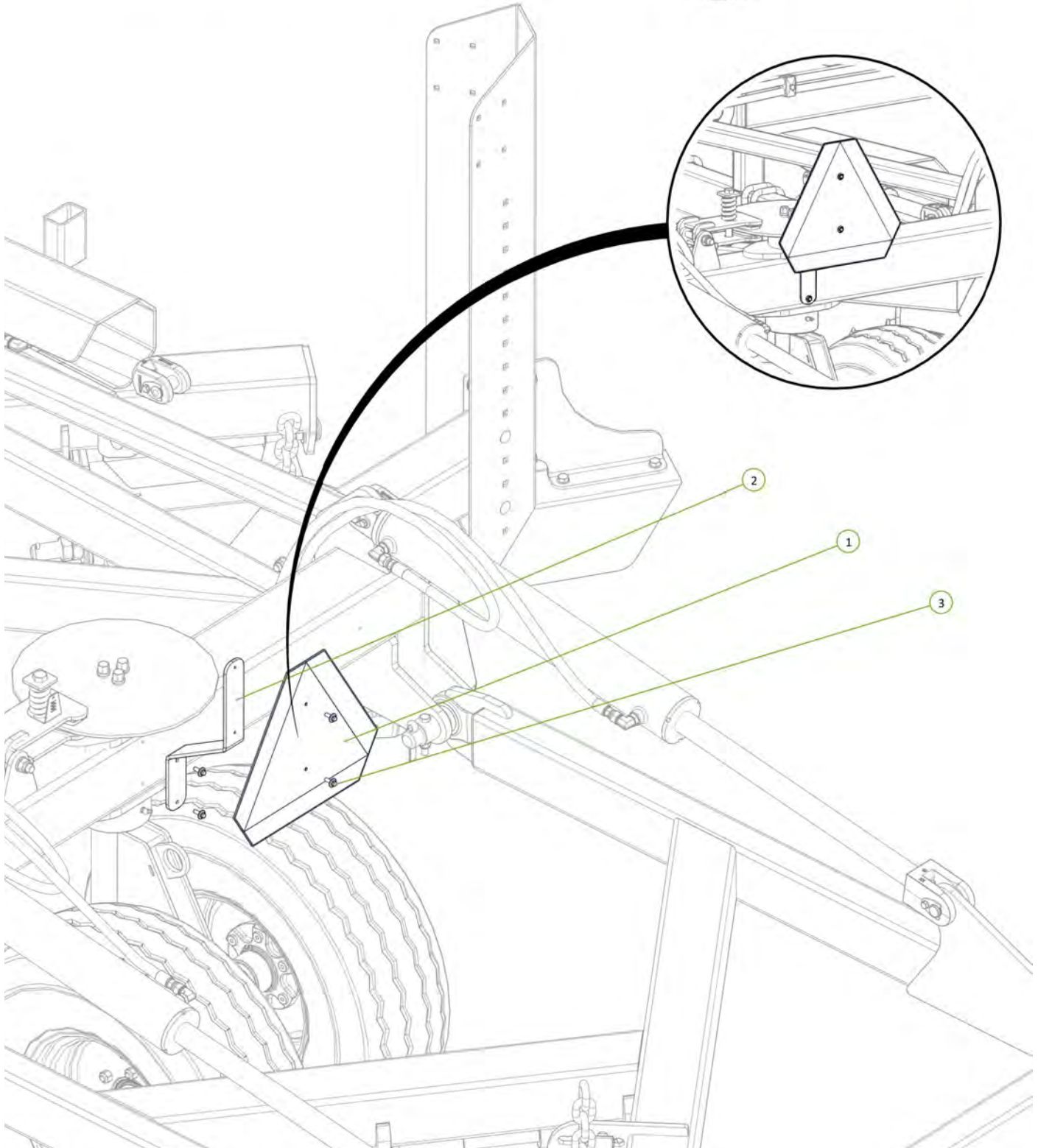



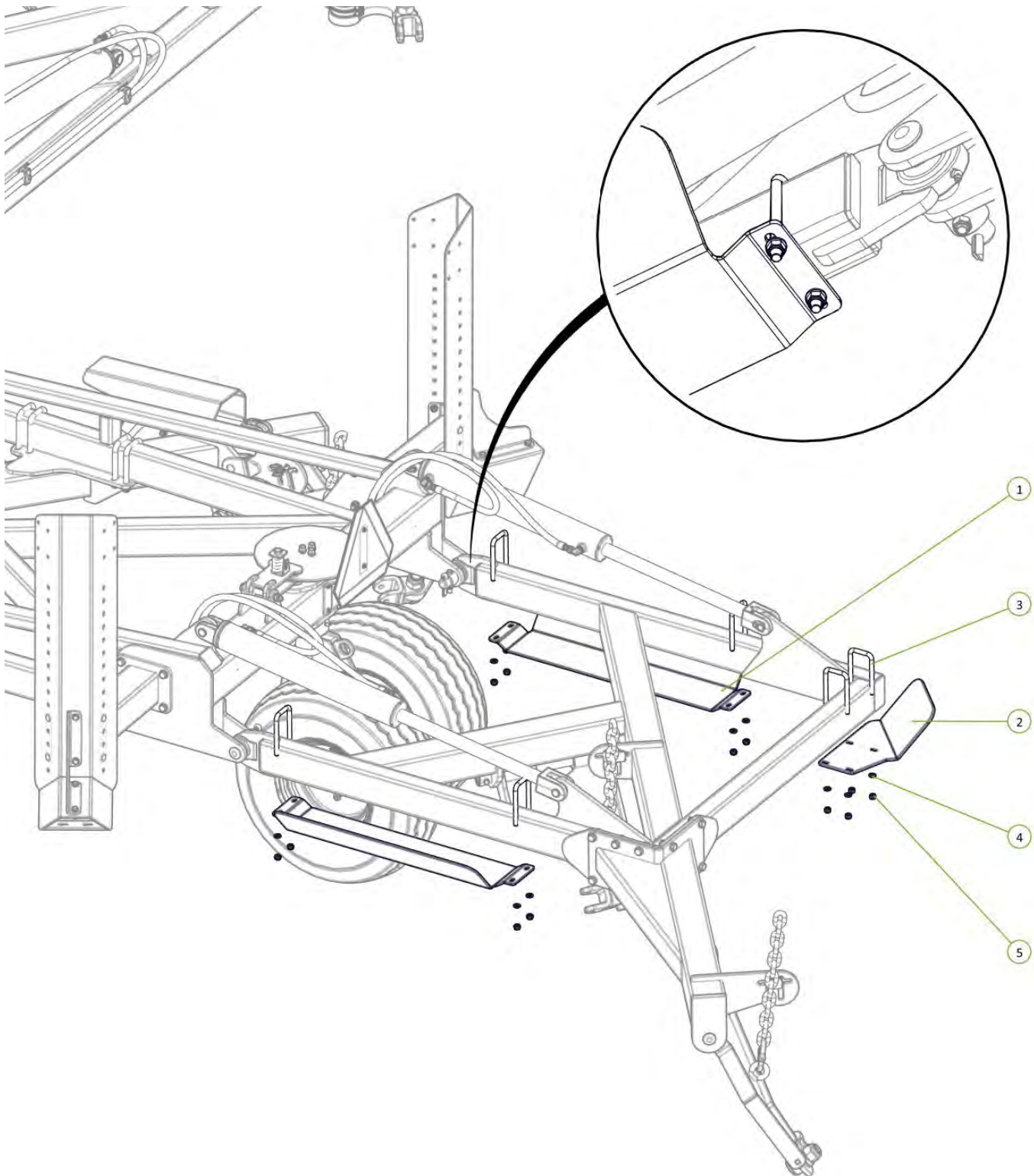

| Item No. | Description                   | Number        | Qty |
|----------|-------------------------------|---------------|-----|
| 1        | Rear Tail Guard               | 0800-235      | 2   |
| 2        | Angled Chain Gaurd            | 0800-498      | 1   |
| 3        | U-Bolt M12 157 Deep x 79 Wide | 0271-1215779U | 6   |
| 4        | Washer Flat M12               | 0231-F12      | 12  |
| 5        | Nyloc Nut M12                 | 0221-NYL12    | 12  |



| Item No. | Description           | Number  | Qty |
|----------|-----------------------|---------|-----|
| 1        | Safety Chain Assembly | 0810-16 | 1   |

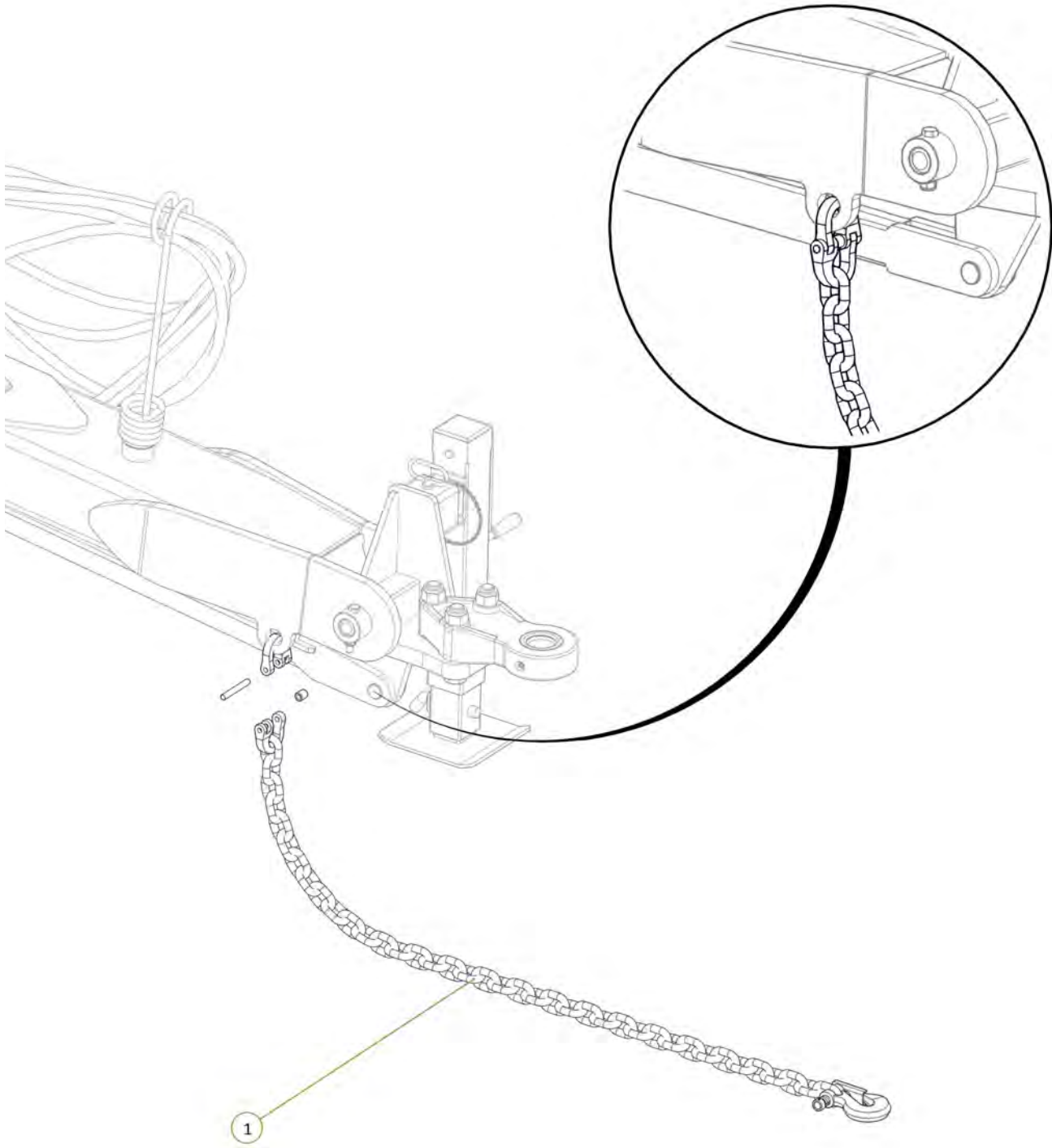
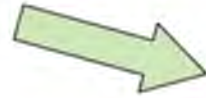

| Item No. | Description                               | Number          | Qty |
|----------|---|-----------------|-----|
| 1        | Operator Manual Cannister                 | 0801-OMC-1      | 1   |
| 2        | Ratcheting Gear Wrench 1 3/4"             | 0802-GW1 3-4    | 1   |
| 3        | 20mm Bolt Swivel Unit                     | 0802-PCHB55     | 1   |
| 4        | M20 x 110 grade 10.9 ZP Short Thread Bolt | 0211-20110ST    | 1   |
| 5        | Nyloc Nut M20                             | 0221-NYL20      | 1   |
| 6        | M6 x 20 Trilobe self tapping ScREW        | 0211-M620MZPHTF | 3   |

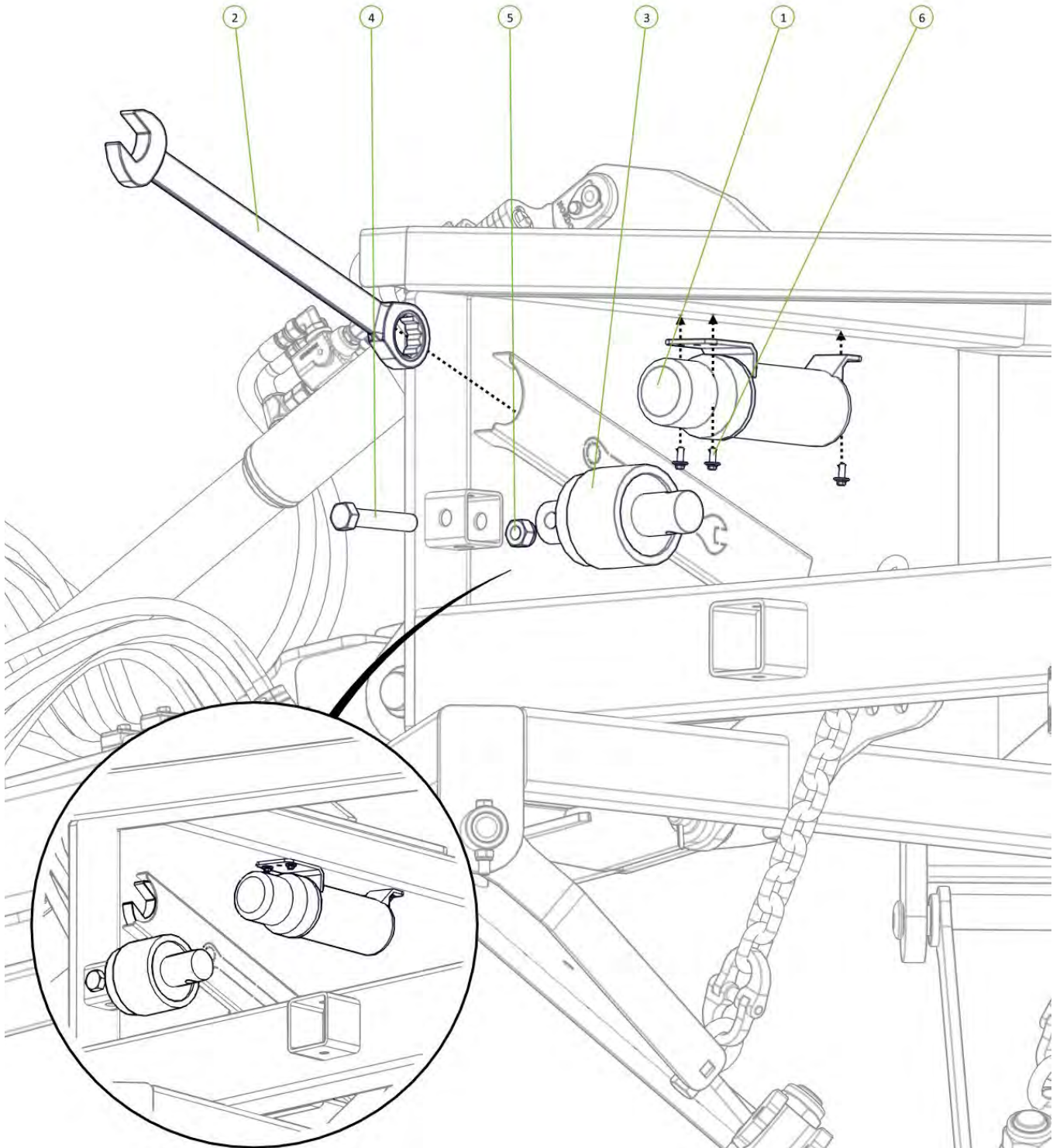
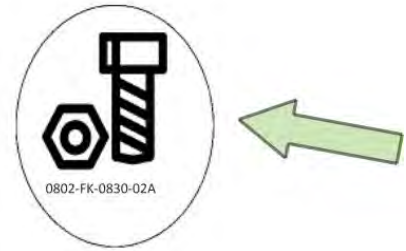



| Item No. | Description                    | Number                | Qty |
|----------|--------------------------------|-----------------------|-----|
| 1        | Cylinder Safety Stop           | 0800-688              | 1   |
| 2        | Square Loop Pin 5/16" x 3 1/4" | 0511-PINLOOPSQ516x314 | 1   |

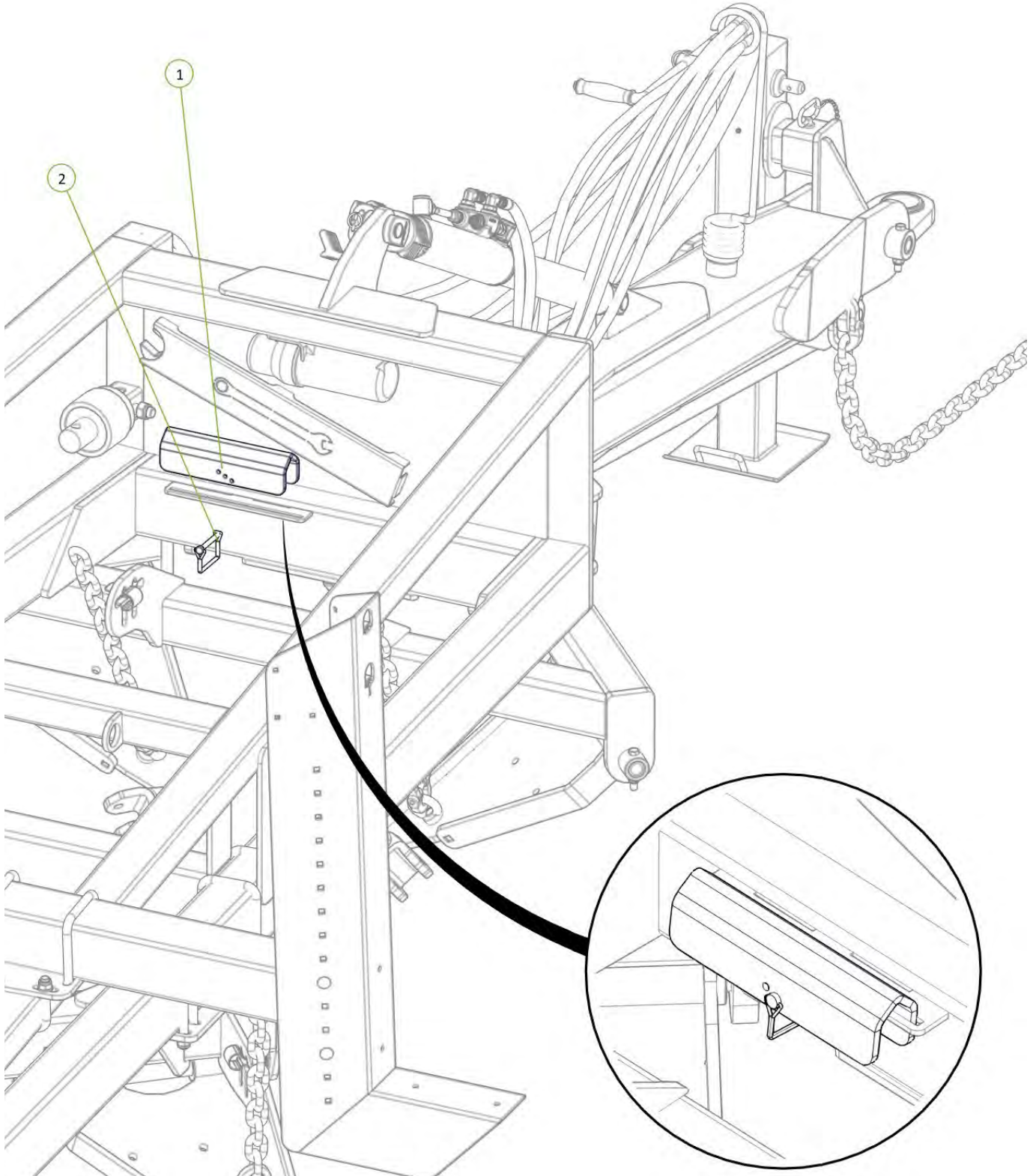

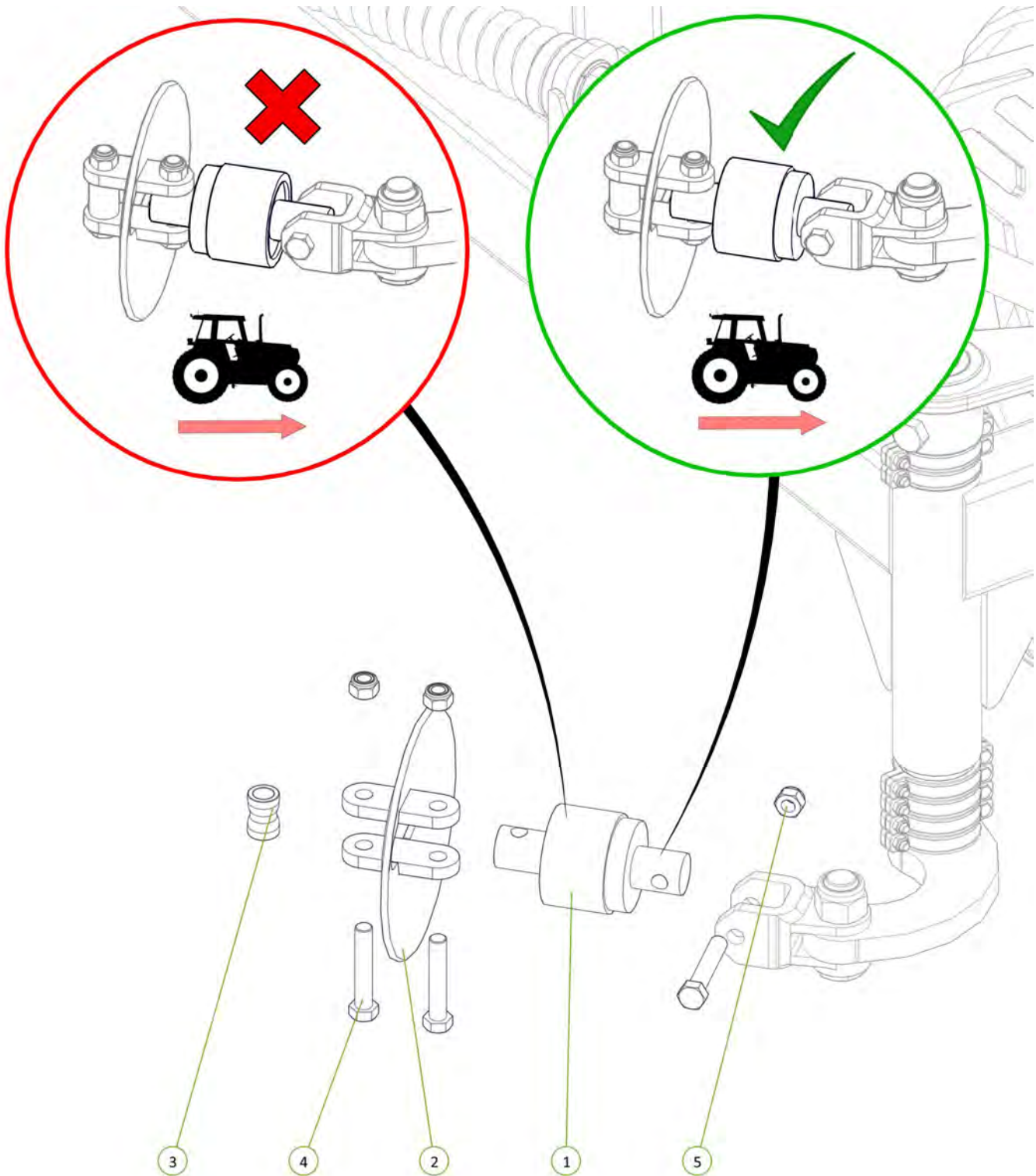

| Item No. | Description                               | Number       | Qty |
|----------|---|--------------|-----|
| 1        | 20mm Bolt Swivel Unit                     | 0802-PCHB55  | 1   |
| 2        | Disc Chain Tie Plate Link 20mm            | 0802-DCTP-20 | 1   |
| 3        | Disc Chain Spacer                         | 0801-253755  | 1   |
| 4        | M20 x 110 grade 10.9 ZP Short Thread Bolt | 0211-20110ST | 3   |
| 5        | Nyloc Nut M20                             | 0221-NYL20   | 3   |





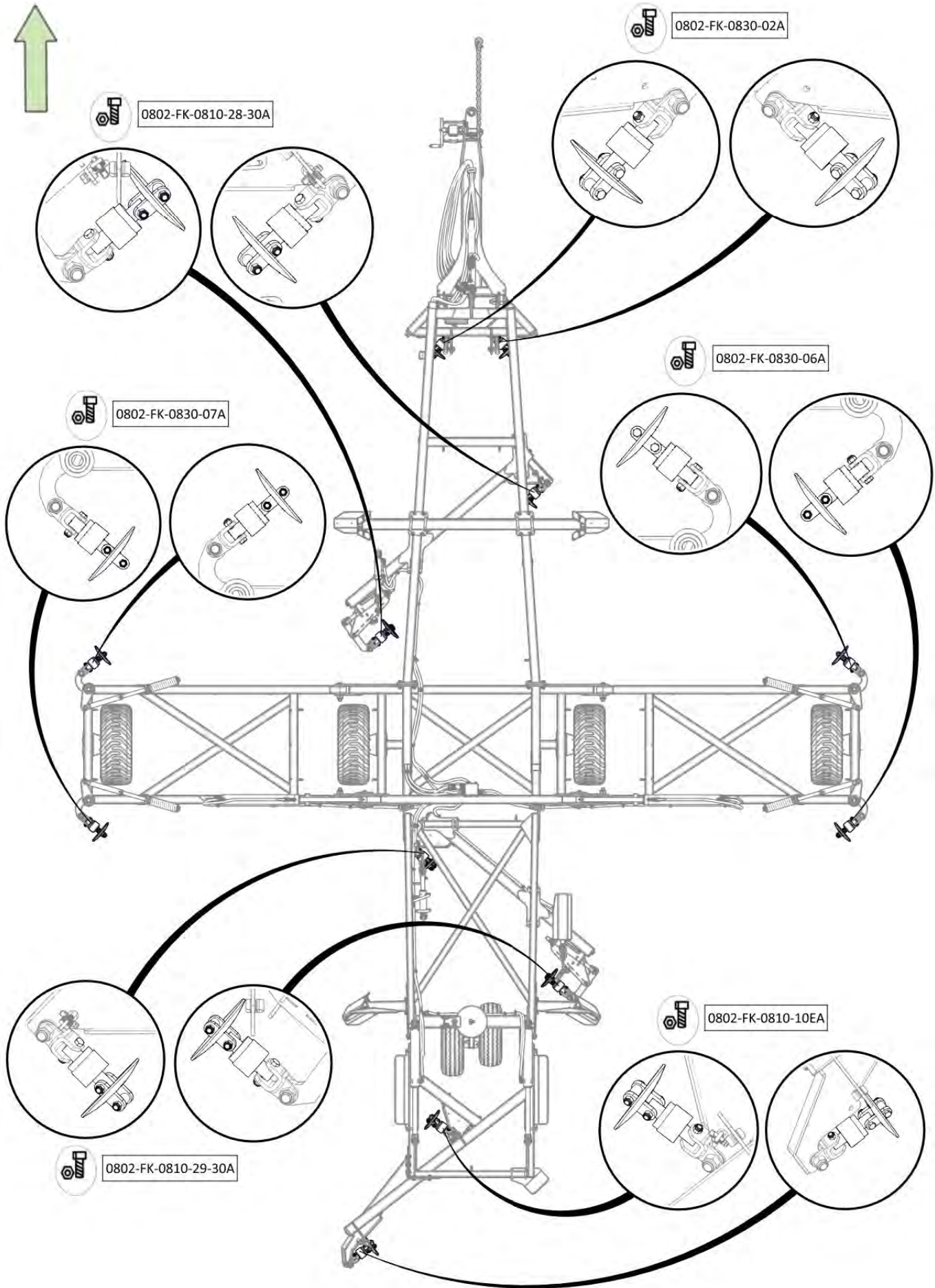



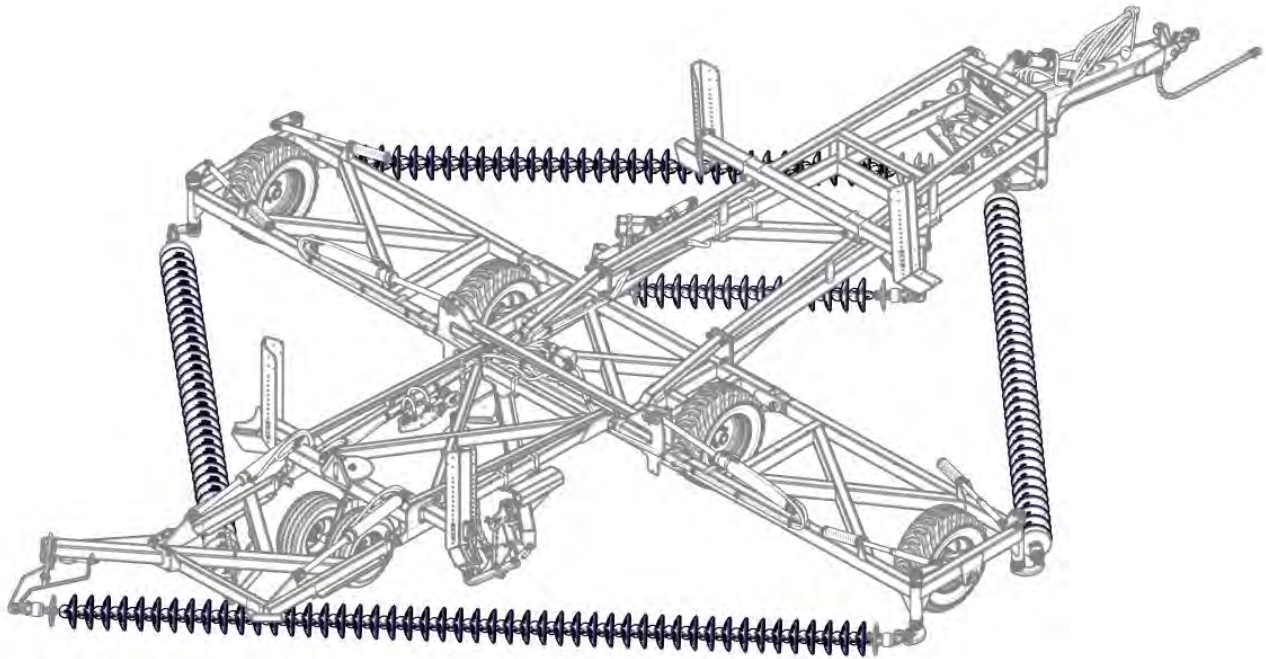



## Section 3 - Decal Placement

1. **CLEAN**  
Wipe application surface and allow to fully dry. Ensure the area is free from dirt and contaminants.
2. **PEEL BACKING**  
Carefully peel away paper backing.
3. **ALIGN AND PRESS**  
Align the decal and carefully place it on surface.
4. **SMOOTH**  
Use a squeegee to smooth design over surface, from top to bottom and to push out all remaining air. Ensure full coverage with no bubbles.

For the Kelly 3009 Decal follow this instructions below:

1. **CLEAN**  
Wipe application surface and allow to fully dry. Ensure the area is free from dirt, and contaminants.
2. **PEEL BACKING**  
Carefully peel away paper backing, ensuring vinyl sticks entirely to tape.
3. **ALIGN AND PRESS**  
Align the decal and carefully place it on surface.
4. **SMOOTH**  
Use a squeegee to smooth design over surface, from top to bottom and to push out all remaining air. Ensure full coverage with no bubbles.
5. **REMOVE TRANSFER TAPE**  
Carefully peel away the transfer tape, beginning at the corner until completely removed. Finally, allow decal to cure for 24 hours before washing.

For the Fold/Unfold Decal (0801-S1), follow this instructions below:

1. **CLEAN**  
Wipe application surface and allow to fully dry. Ensure the area is free from dirt and contaminants.
2. **APPLY SOLUTION**  
Using detergent wet the surface where you'll be applying the decal so you can slide it around.
3. **PEEL BACKING**  
Carefully peel away paper backing.
4. **ALIGN AND PRESS**  
Align the decal and carefully place it on surface.
5. **SMOOTH**  
Use a squeegee to smooth design over surface, from center to corners and to push out all remaining air. Ensure full coverage with no bubbles.

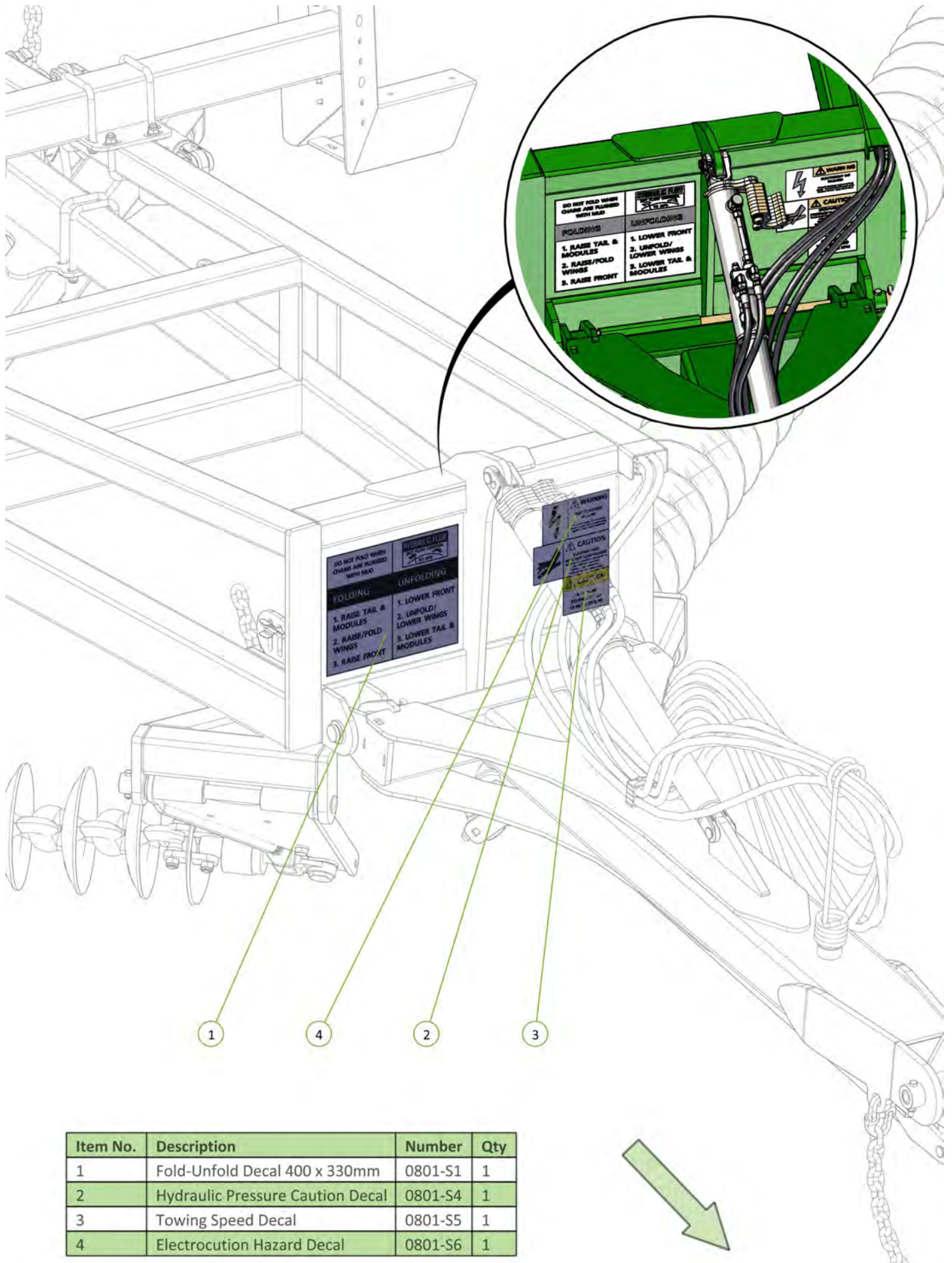

| Item No. | Description                      | Number  | Qty |
|----------|----------------------------------|---------|-----|
| 1        | Fold-Unfold Decal 400 x 330mm    | 0801-S1 | 1   |
| 2        | Hydraulic Pressure Caution Decal | 0801-S4 | 1   |
| 3        | Towing Speed Decal               | 0801-S5 | 1   |
| 4        | Electrocution Hazard Decal       | 0801-S6 | 1   |





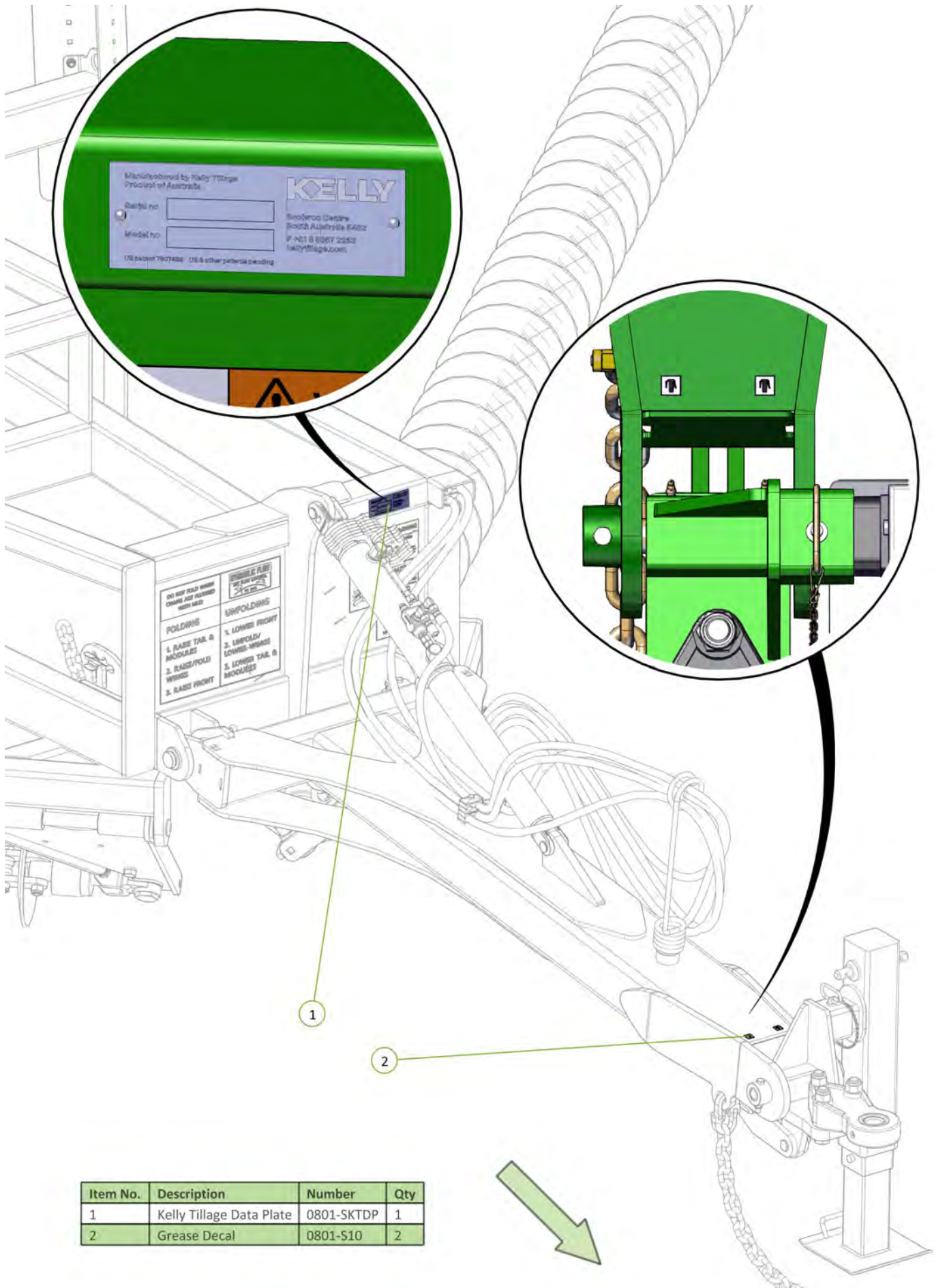

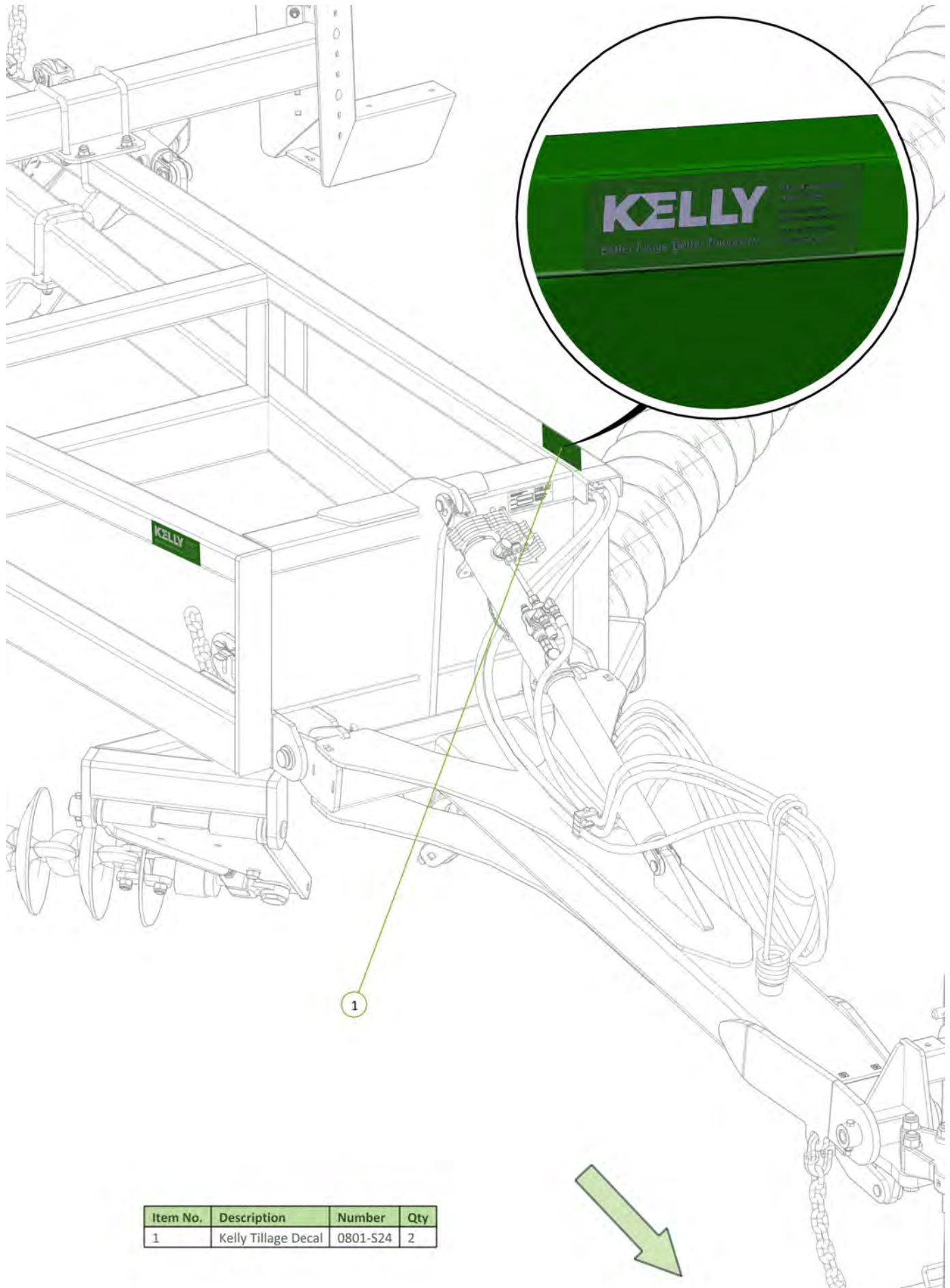

| Item No. | Description         | Number   | Qty |
|----------|---------------------|----------|-----|
| 1        | Kelly Tillage Decal | 0801-524 | 2   |

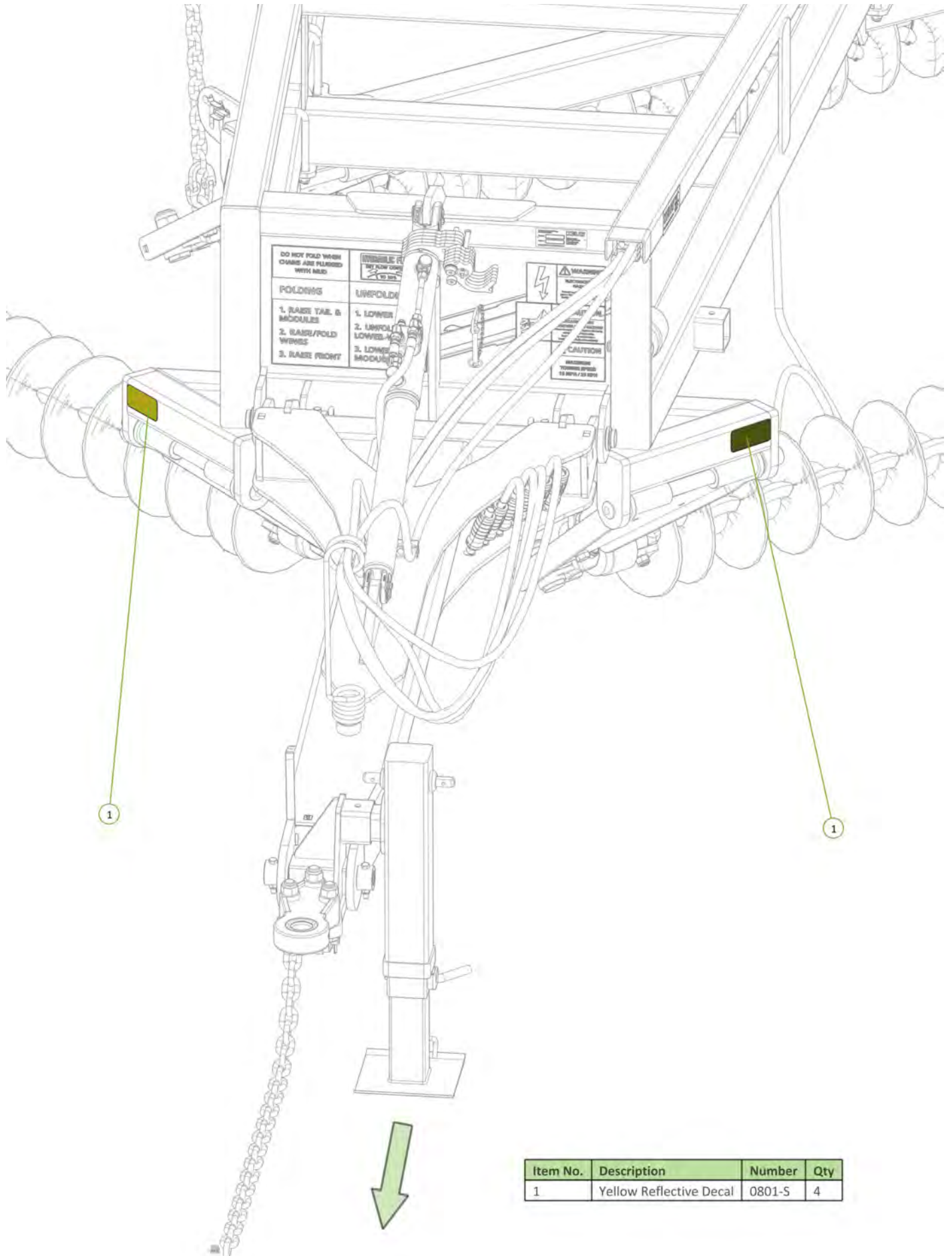



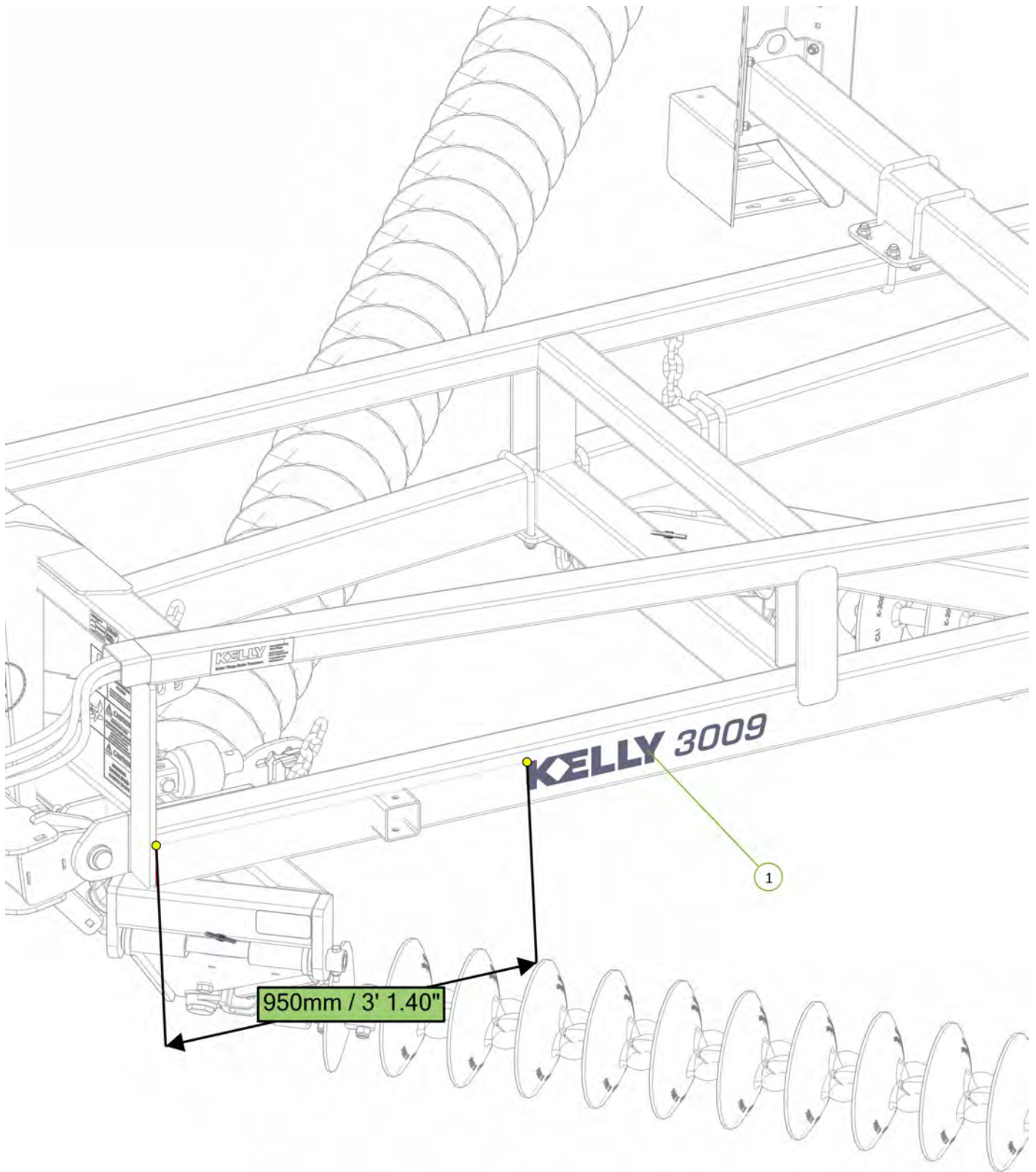

| Item No. | Description              | Number       | Qty |
|----------|--------------------------|--------------|-----|
| 1        | Kelly Tillage 3009 Decal | 0801-SKT3009 | 1   |



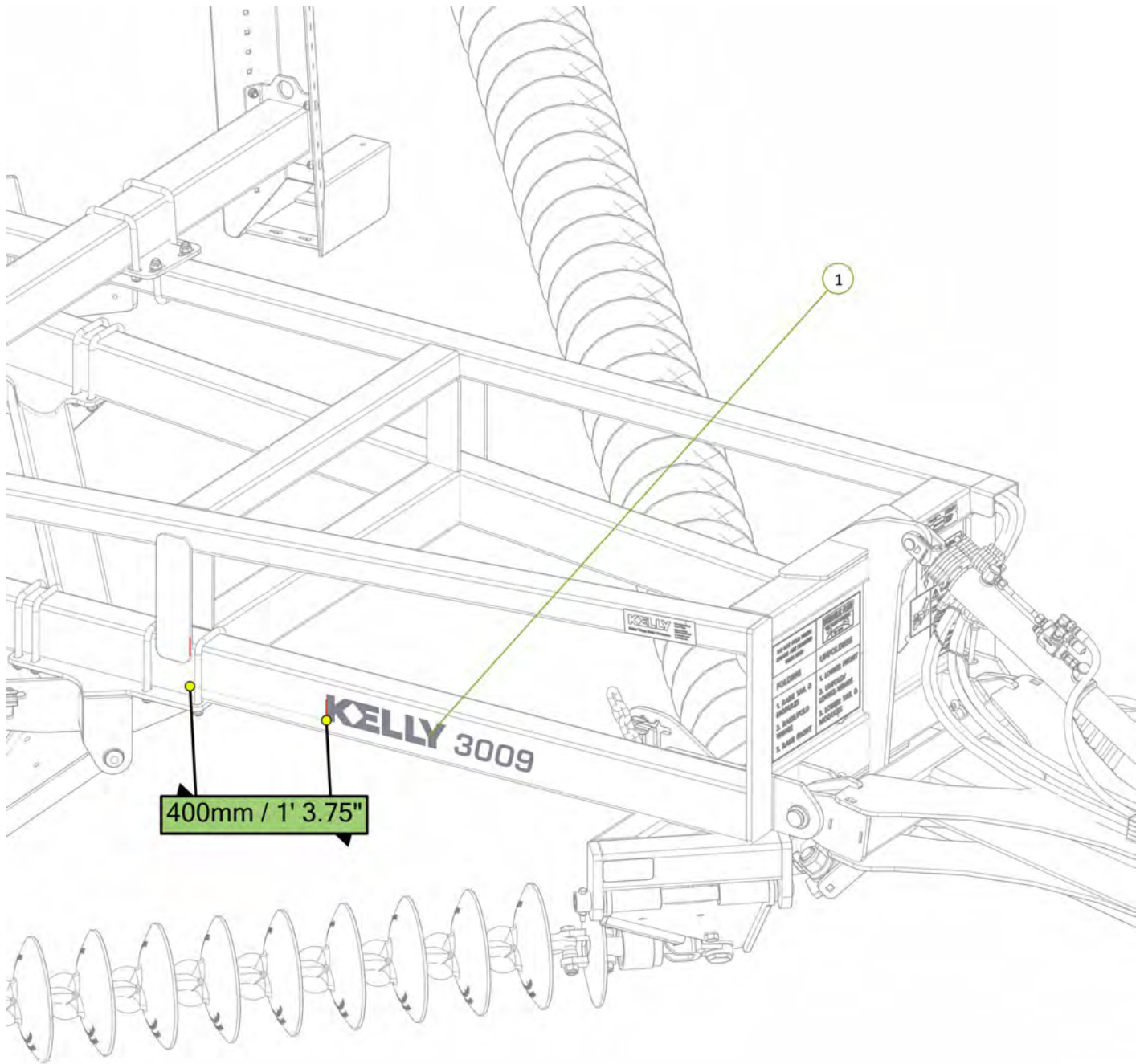

| Item No. | Description              | Number       | Qty |
|----------|--------------------------|--------------|-----|
| 1        | Kelly Tillage 3009 Decal | 0801-SKT3009 | 1   |



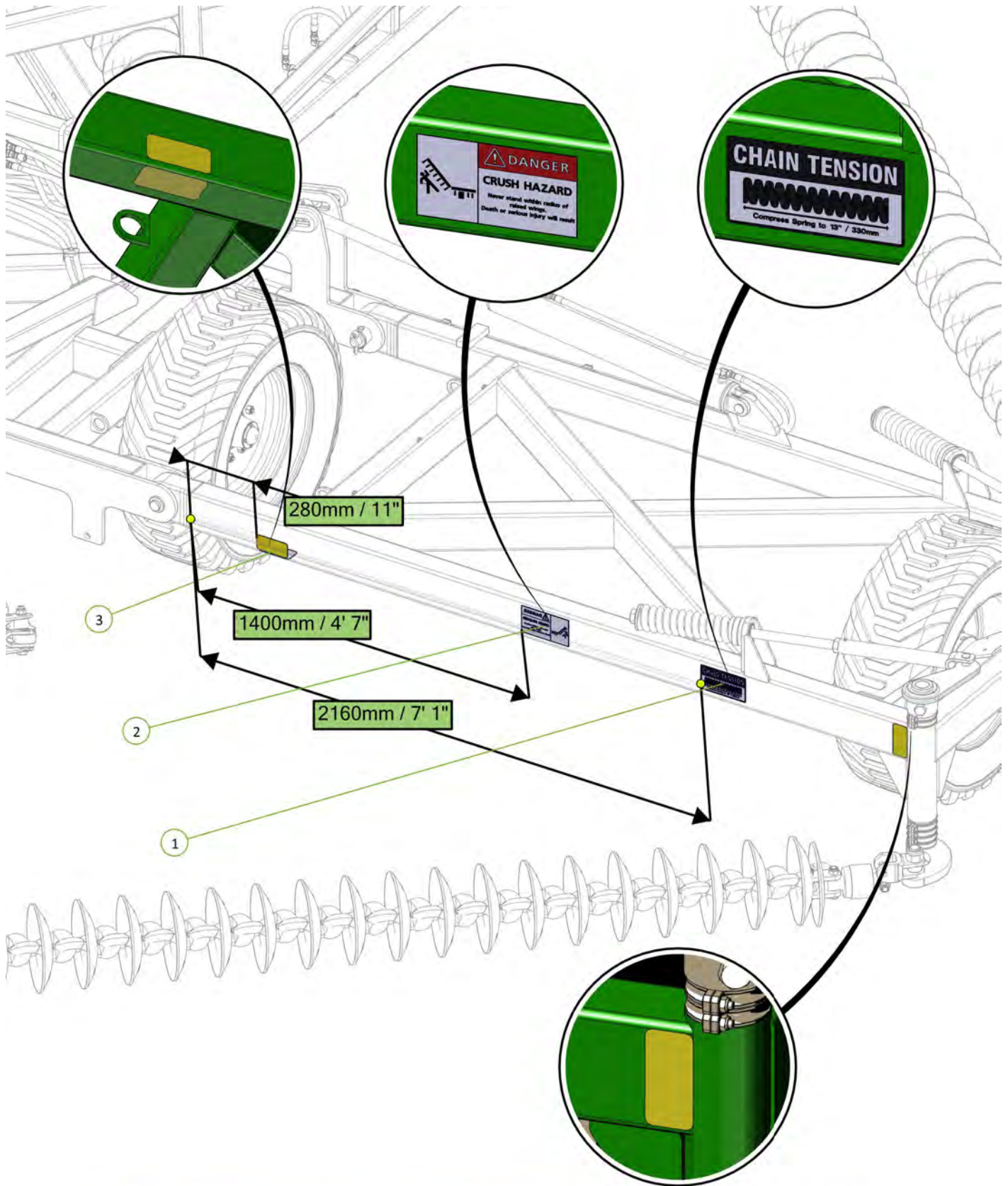

| Item No. | Description               | Number    | Qty |
|----------|---------------------------|-----------|-----|
| 1        | Chain Tension 330mm Decal | 0801-S15  | 1   |
| 2        | Danger Crush Hazard Decal | 0801-S3   | 1   |
| 3        | Yellow Reflective Decal   | 0801-SYRF | 3   |





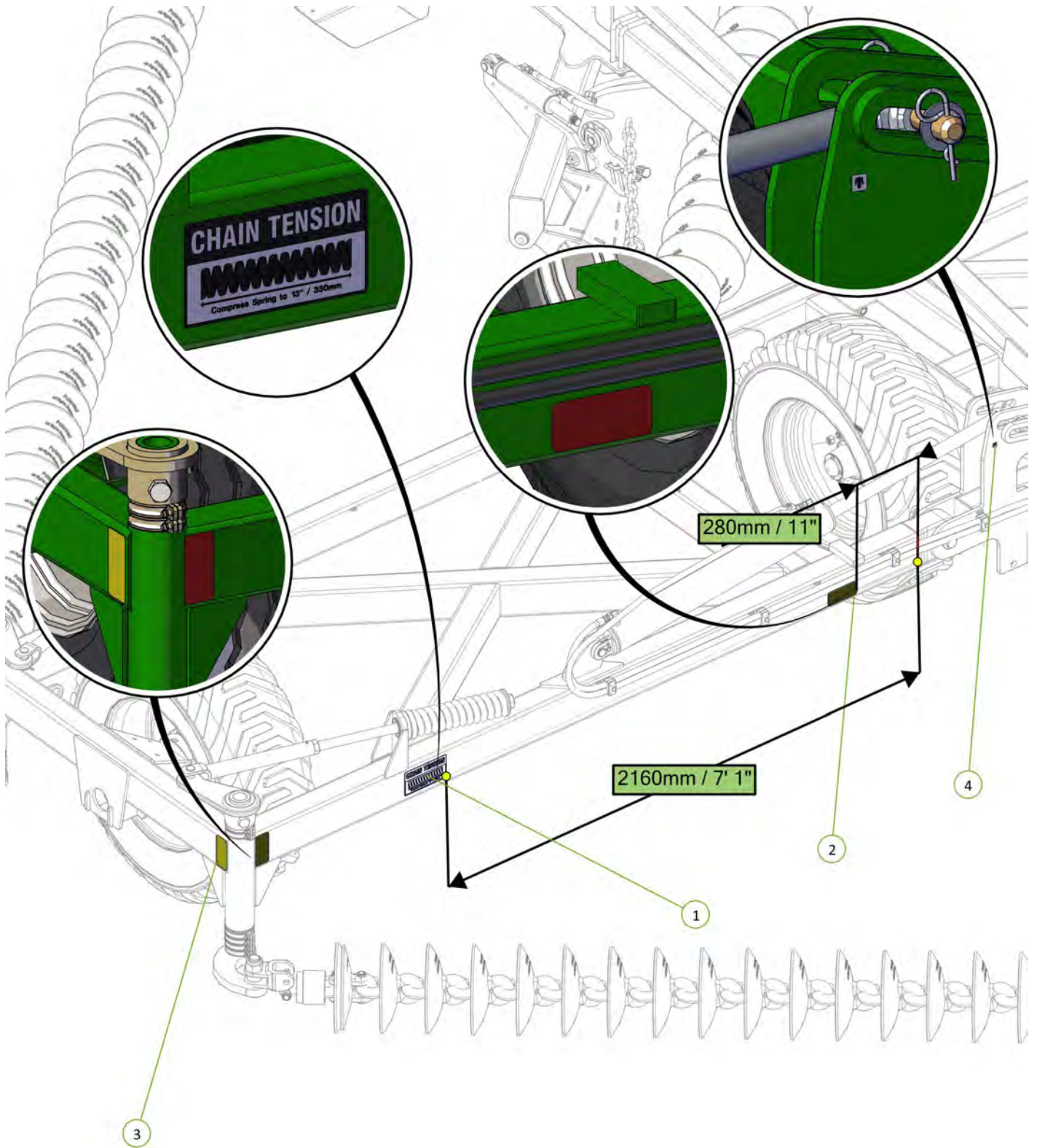

| Item No. | Description               | Number    | Qty |
|----------|---------------------------|-----------|-----|
| 1        | Chain Tension 330mm Decal | 0801-S15  | 1   |
| 2        | Red Reflective Decal      | 0801-SRRF | 2   |
| 3        | Yellow Reflective Decal   | 0801-SYRF | 1   |
| 4        | Grease Decal              | 0801-S10  | 1   |



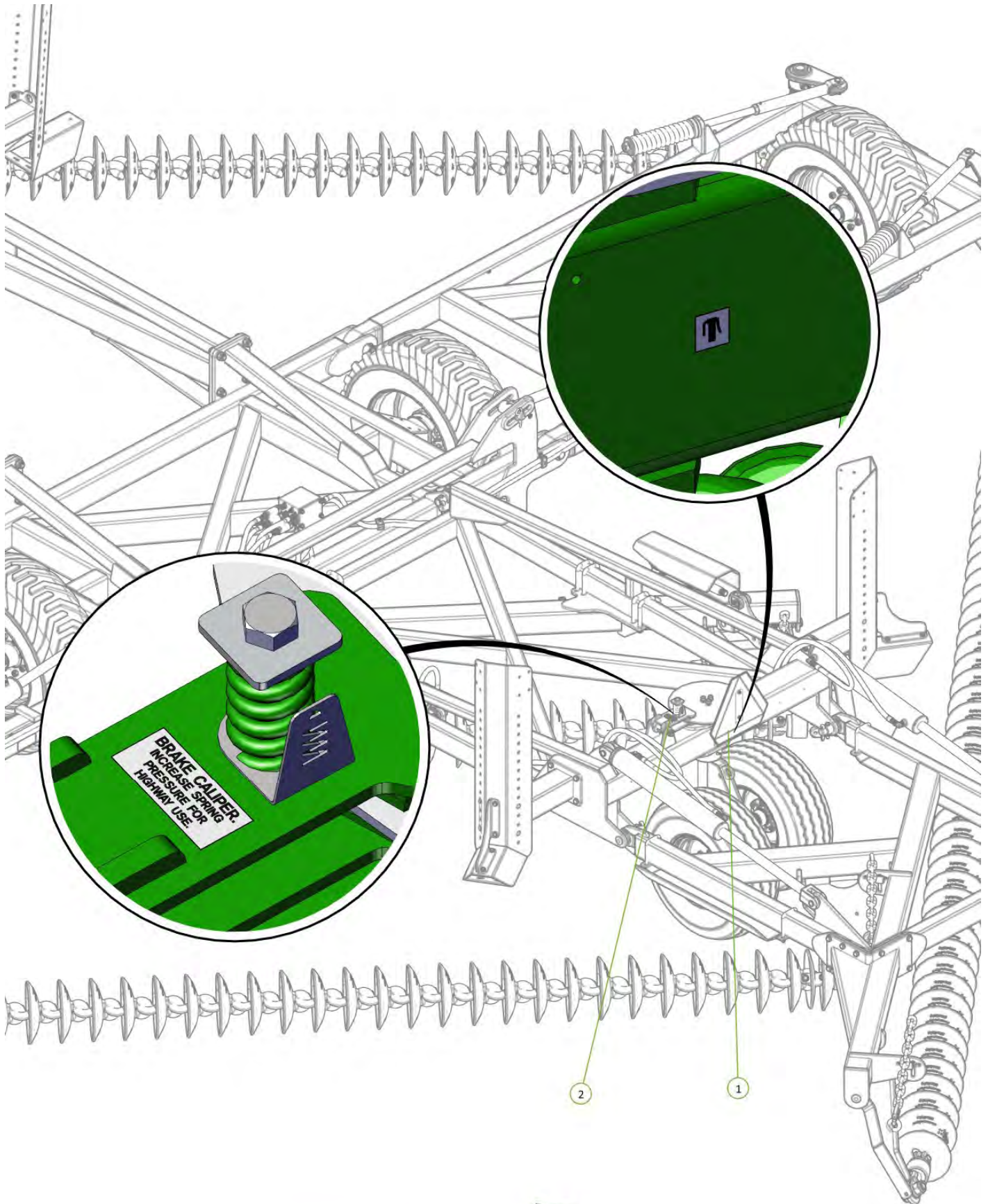

| Item No. | Description         | Number   | Qty |
|----------|---------------------|----------|-----|
| 1        | Grease Decal        | 0801-S10 | 1   |
| 2        | Brake Caliper Decal | 0801-S11 | 1   |



| Item No. | Description             | Number    | Qty |
|----------|-------------------------|-----------|-----|
| 1        | Yellow Reflective Decal | 0801-SYRF | 1   |

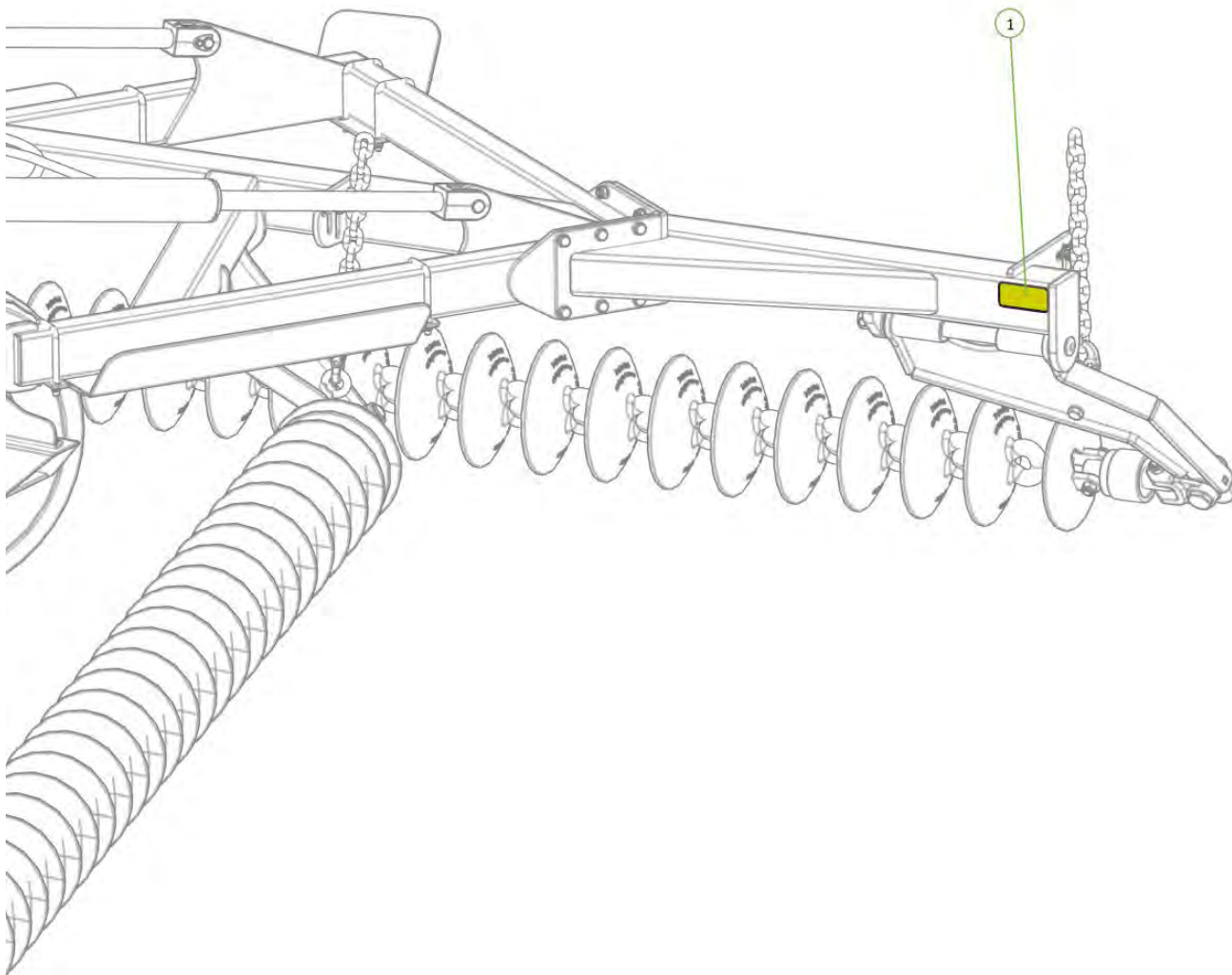



| Item No. | Description             | Number    | Qty |
|----------|-------------------------|-----------|-----|
| 1        | Yellow Reflective Decal | 0801-SYRF | 1   |

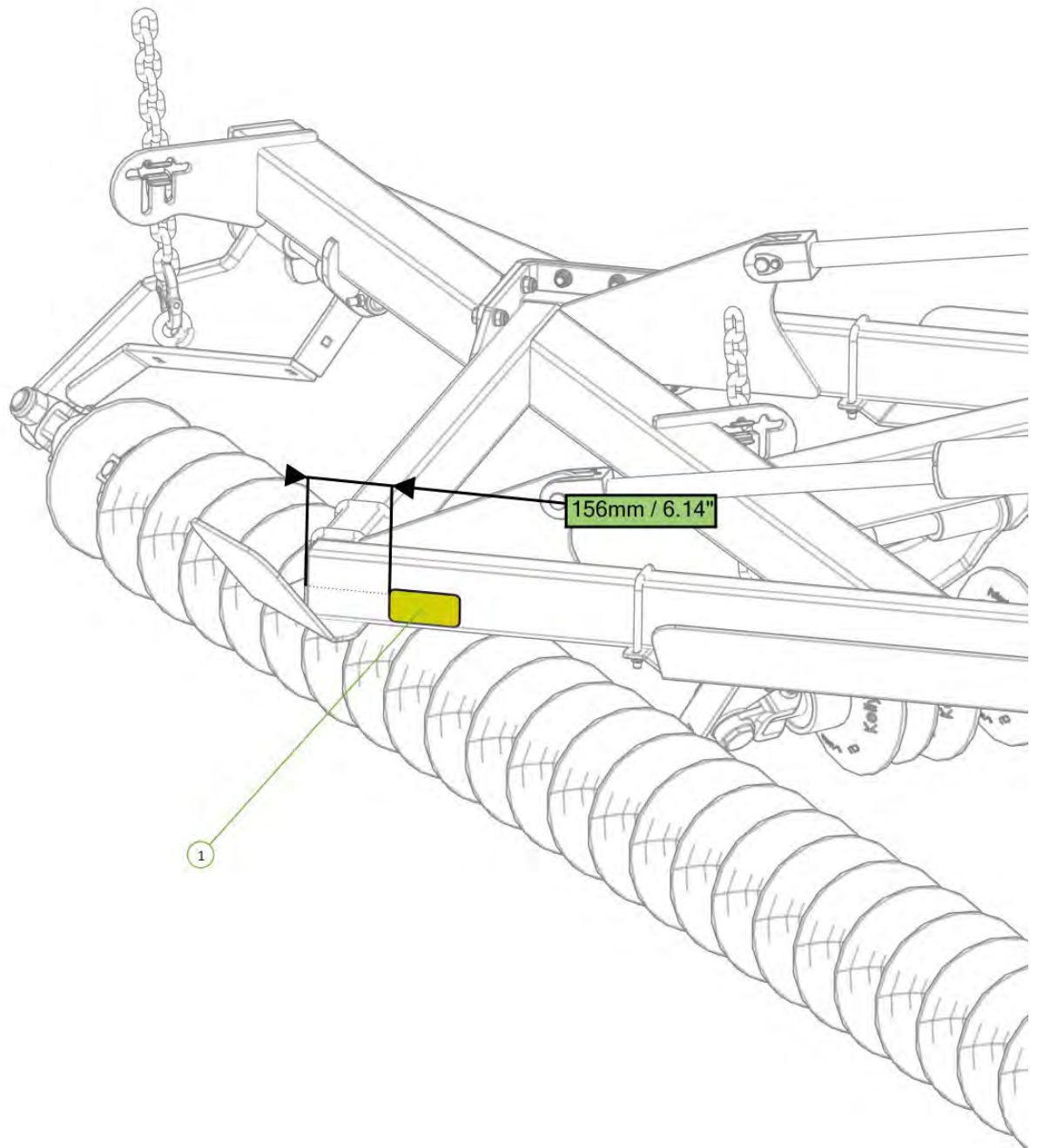

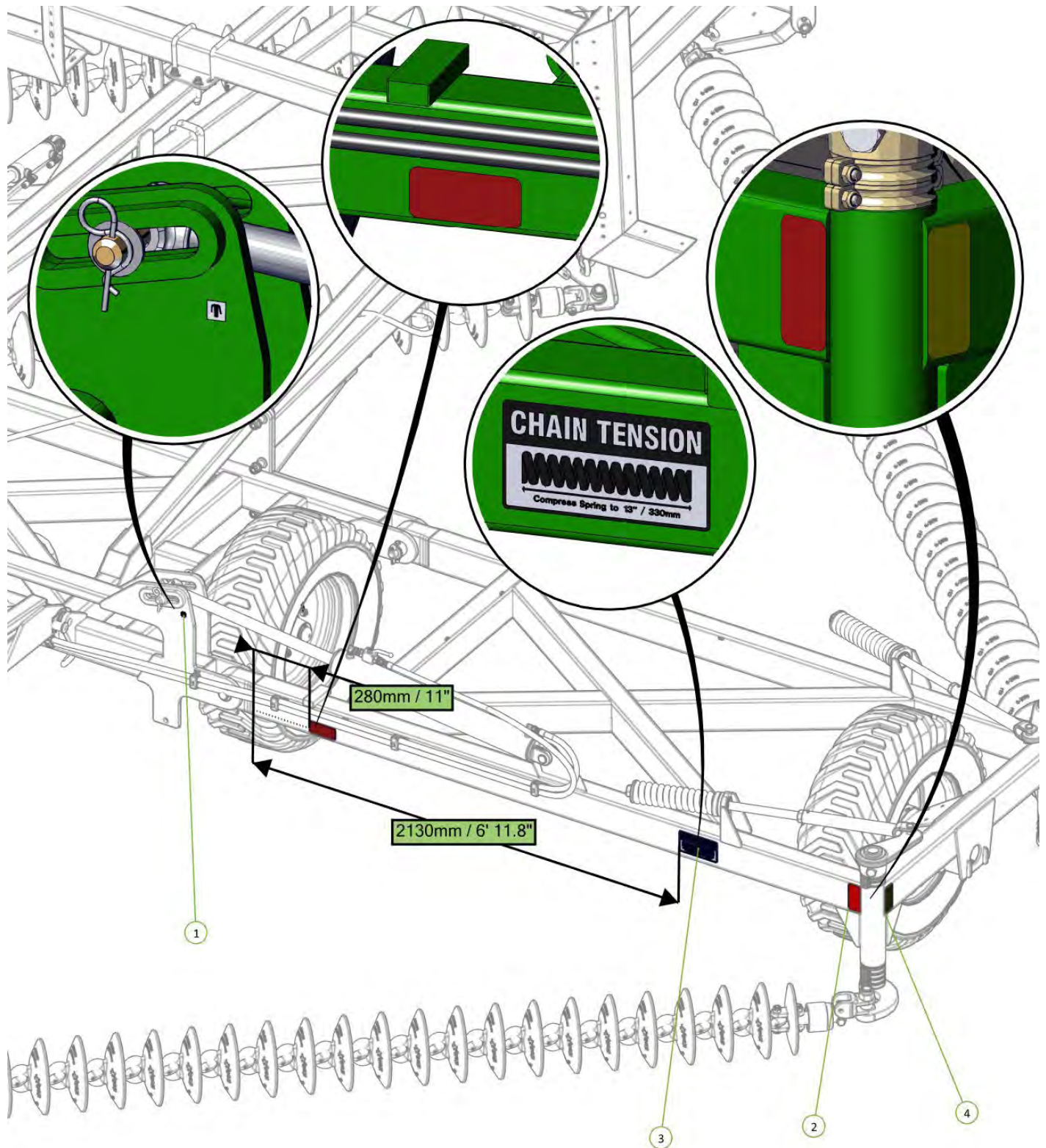

| Item No. | Description               | Number    | Qty |
|----------|---------------------------|-----------|-----|
| 1        | Grease Decal              | 0801-S10  | 1   |
| 2        | Red Reflective Decal      | 0801-SRRF | 2   |
| 3        | Chain Tension 330mm Decal | 0801-S15  | 1   |
| 4        | Yellow Reflective Decal   | 0801-SYRF | 1   |





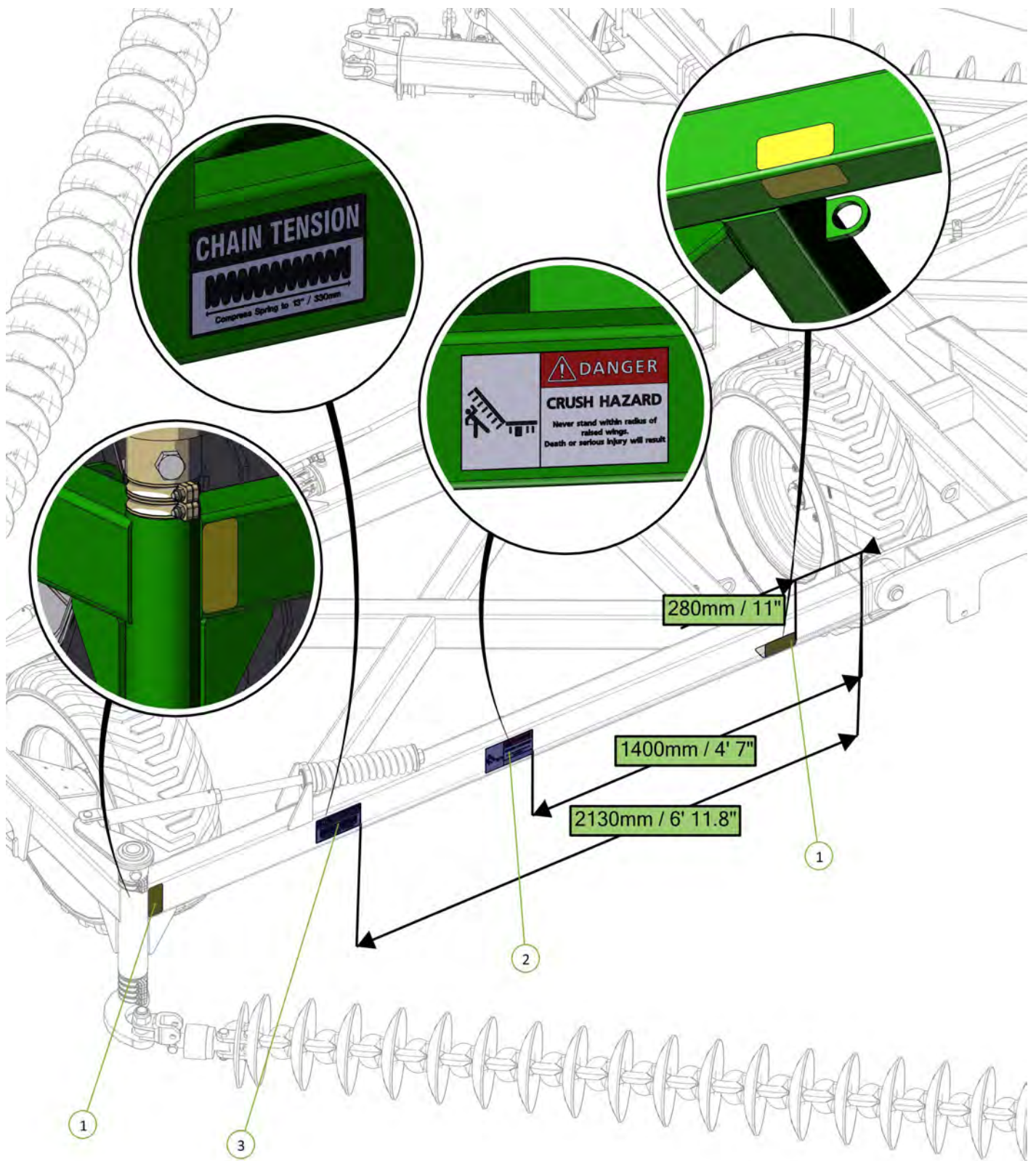

| Item No. | Description               | Number    | Qty |
|----------|---------------------------|-----------|-----|
| 1        | Yellow Reflective Decal   | 0801-SYRF | 3   |
| 2        | Danger Crush Hazard Decal | 0801-S3   | 1   |
| 3        | Chain Tension 330mm Decal | 0801-S15  | 1   |





| Item No. | Description                       | Number              | Qty |
|----------|-----------------------------------|---------------------|-----|
| 1        | Decal, 11L-15 Tyre Inflation      | 0801-58-11L-15      | 2   |
| 2        | Decal, 400/55/22.5 Tyre Inflation | 0801-58-400-55-22.5 | 4   |
| 3        | Wheel Nut Decal                   | 0801-59             | 6   |

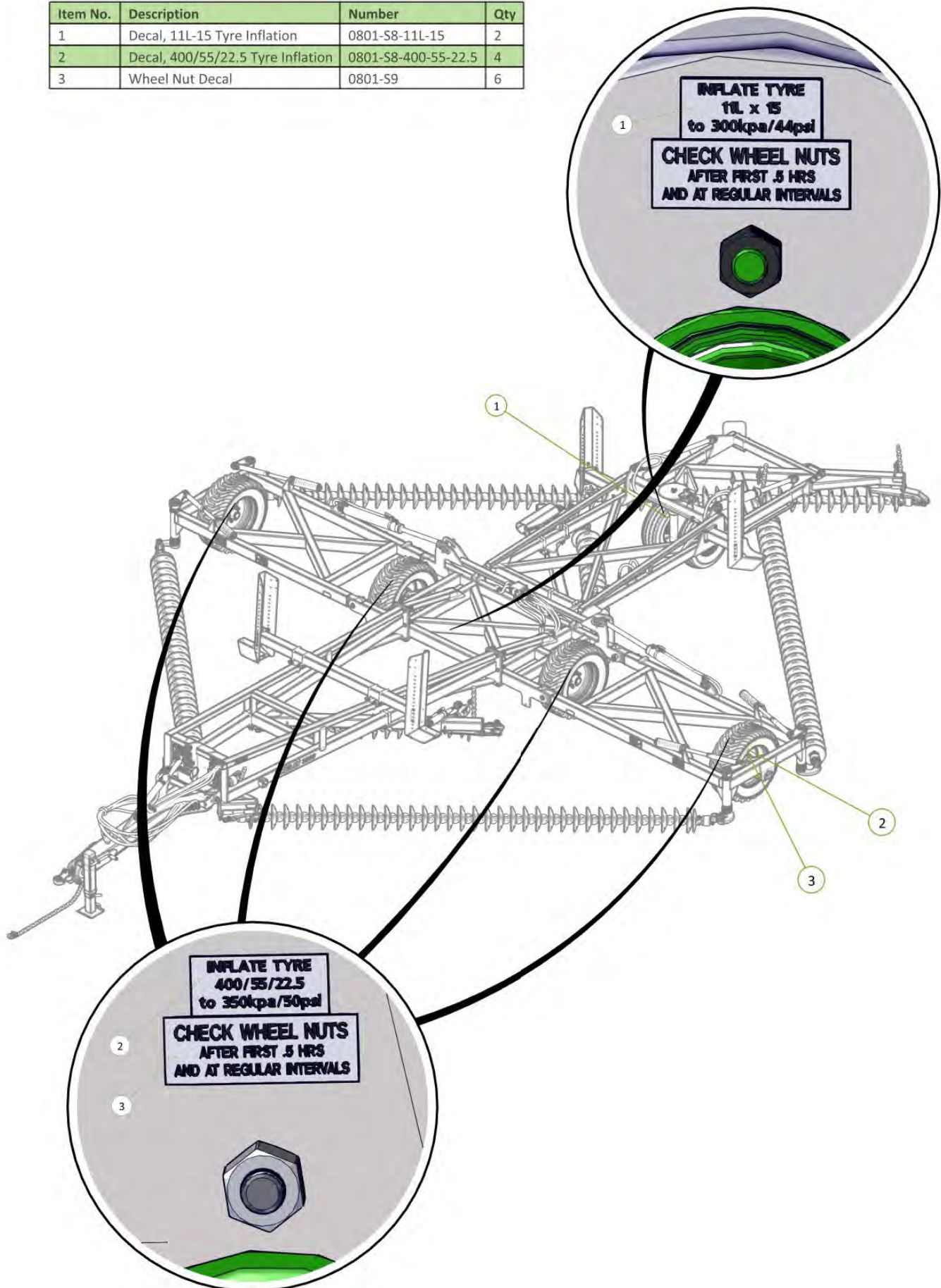

# KELLY

## Section 4 - Light Kit

| Item No. | Description                  | Number      | Qty |
|----------|------------------------------|-------------|-----|
| 1        | Wing light bracket           | 0800-296    | 2   |
| 2        | Socket Head Bolt M6 x 170 zp | 0211-SH6170 | 8   |
| 3        | Nyloc Nut M6                 | 0221-NYL6   | 2   |

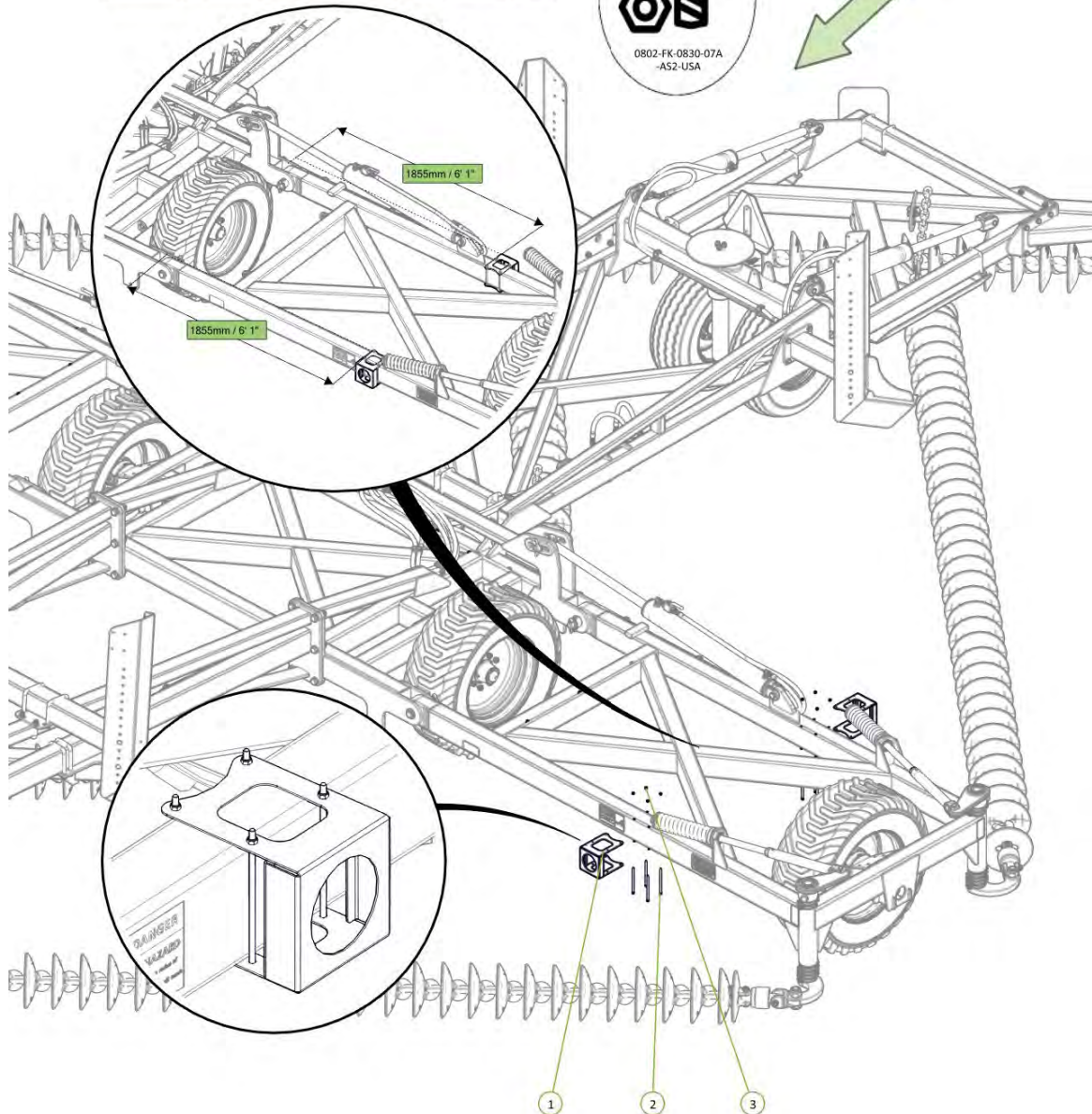



| Item No. | Description                  | Number      | Qty |
|----------|------------------------------|-------------|-----|
| 1        | Wing light bracket           | 0800-296    | 2   |
| 2        | Socket Head Bolt M6 x 170 zp | 0211-SH6170 | 8   |
| 3        | Nyloc Nut M6                 | 0221-NYL6   | 8   |

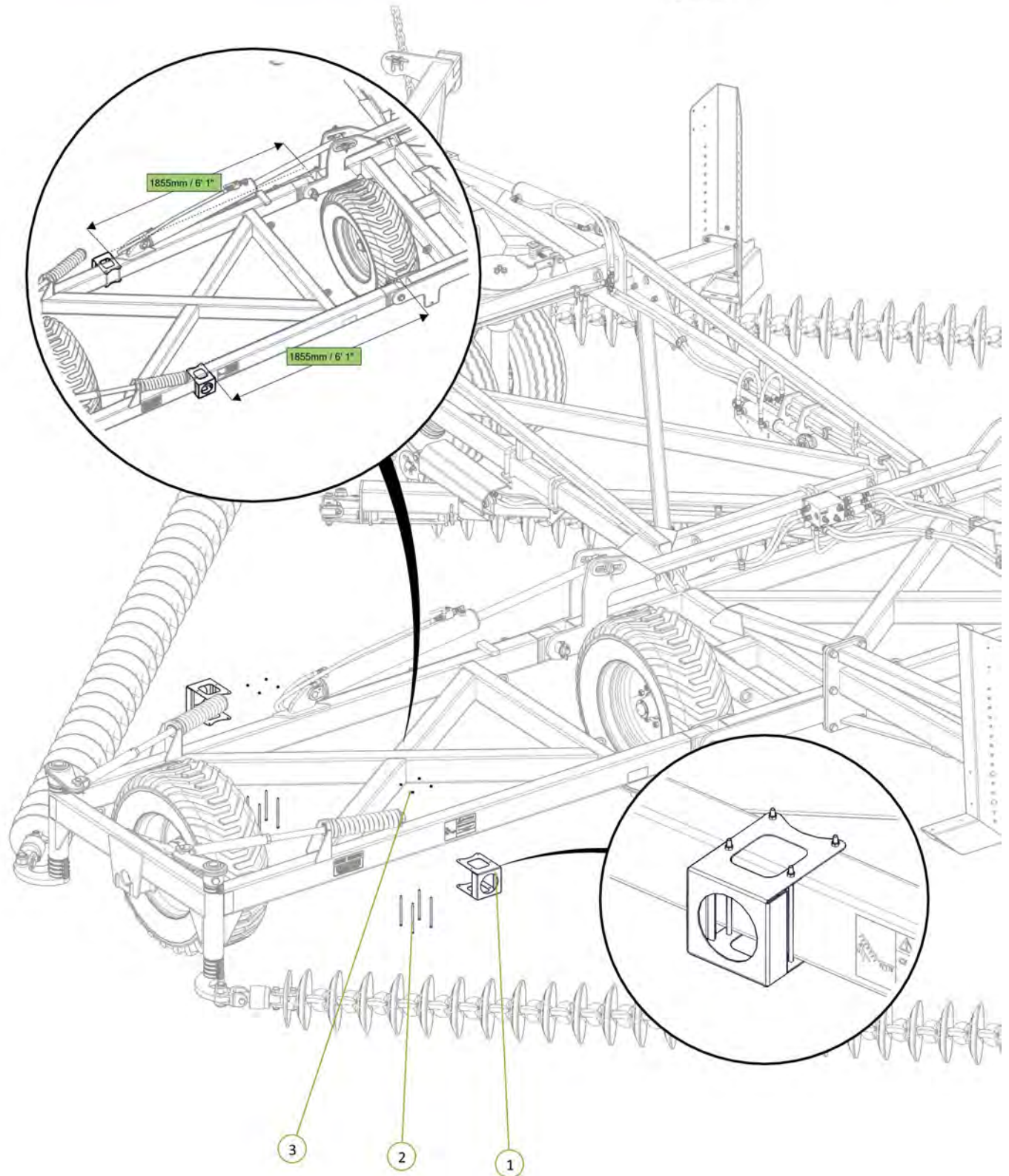



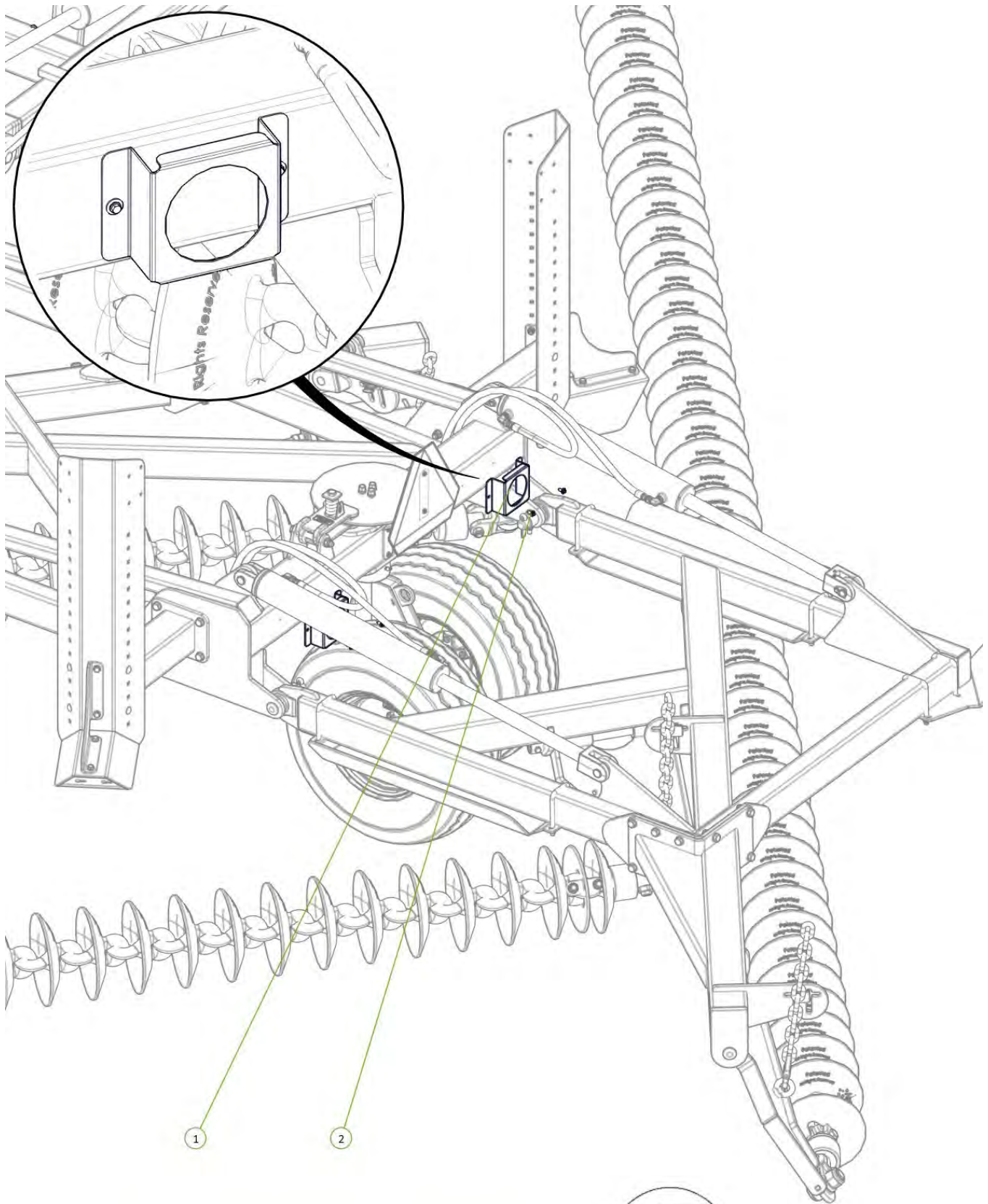

| Item No. | Description                       | Number          | Qty |
|----------|-----------------------------------|-----------------|-----|
| 1        | US Tail Light Bracket             | 0800-194.1      | 2   |
| 2        | M6 x 20 Trilobe self tapping Scew | 0211-M620MZPTHF | 4   |



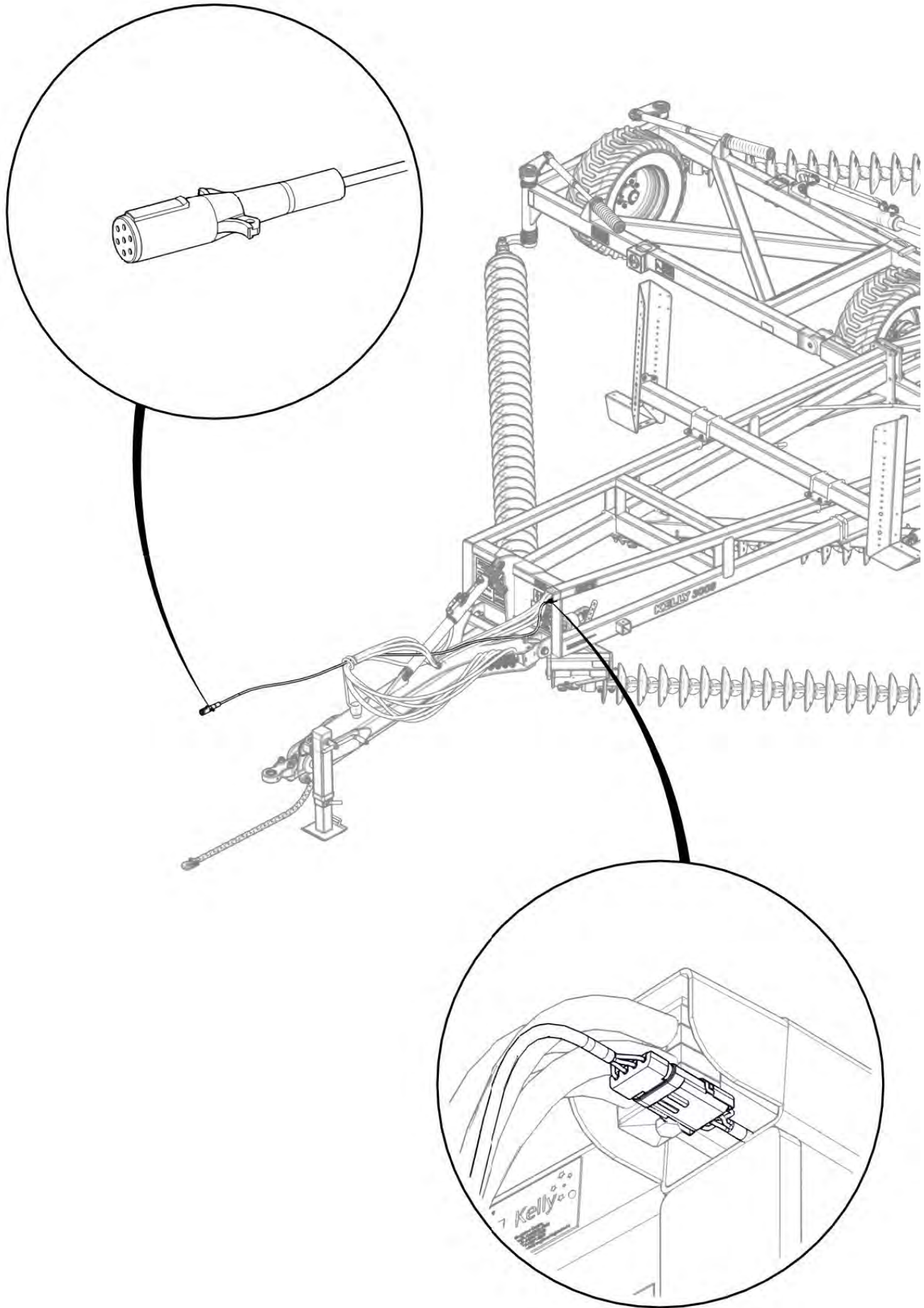



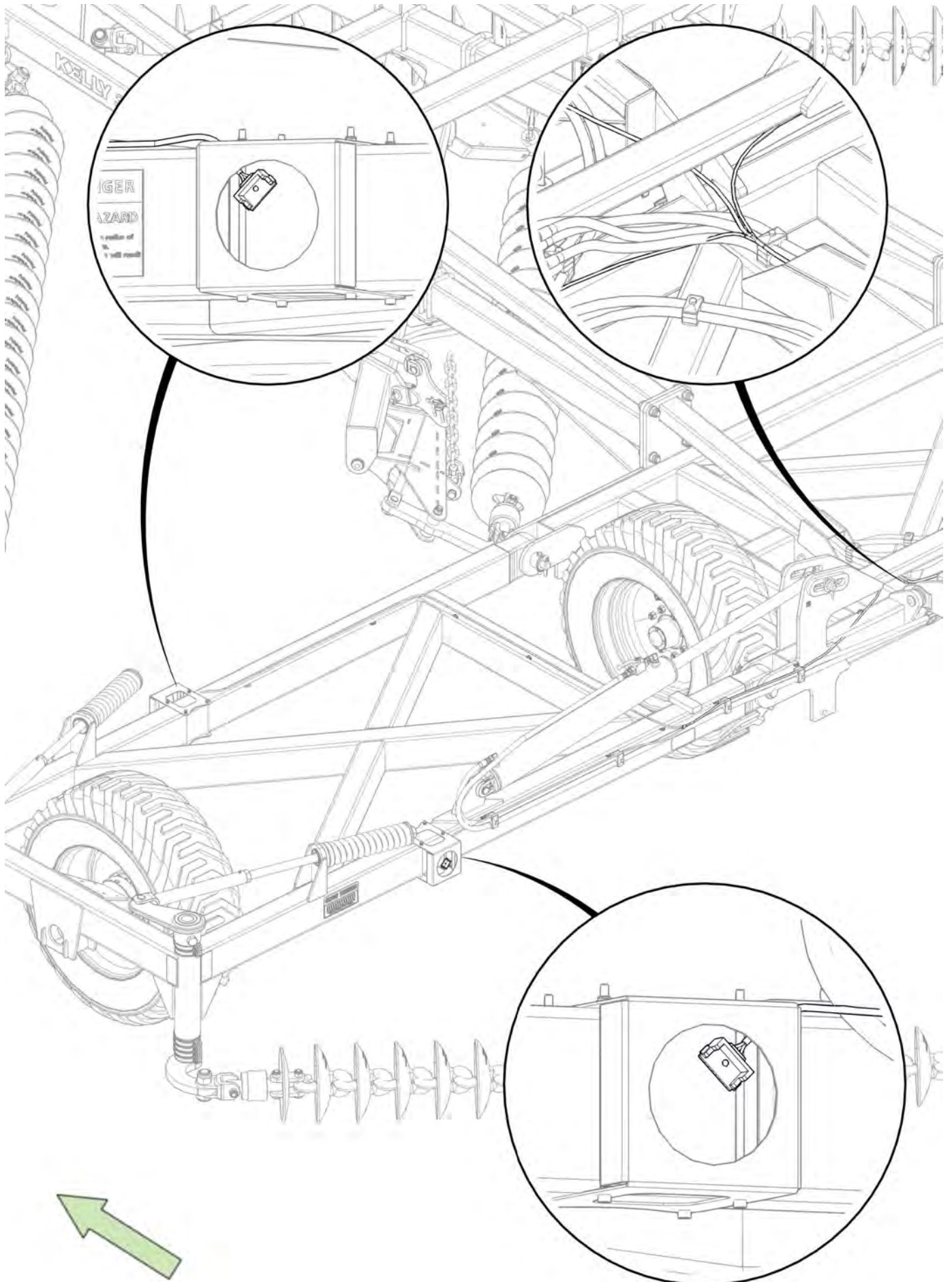



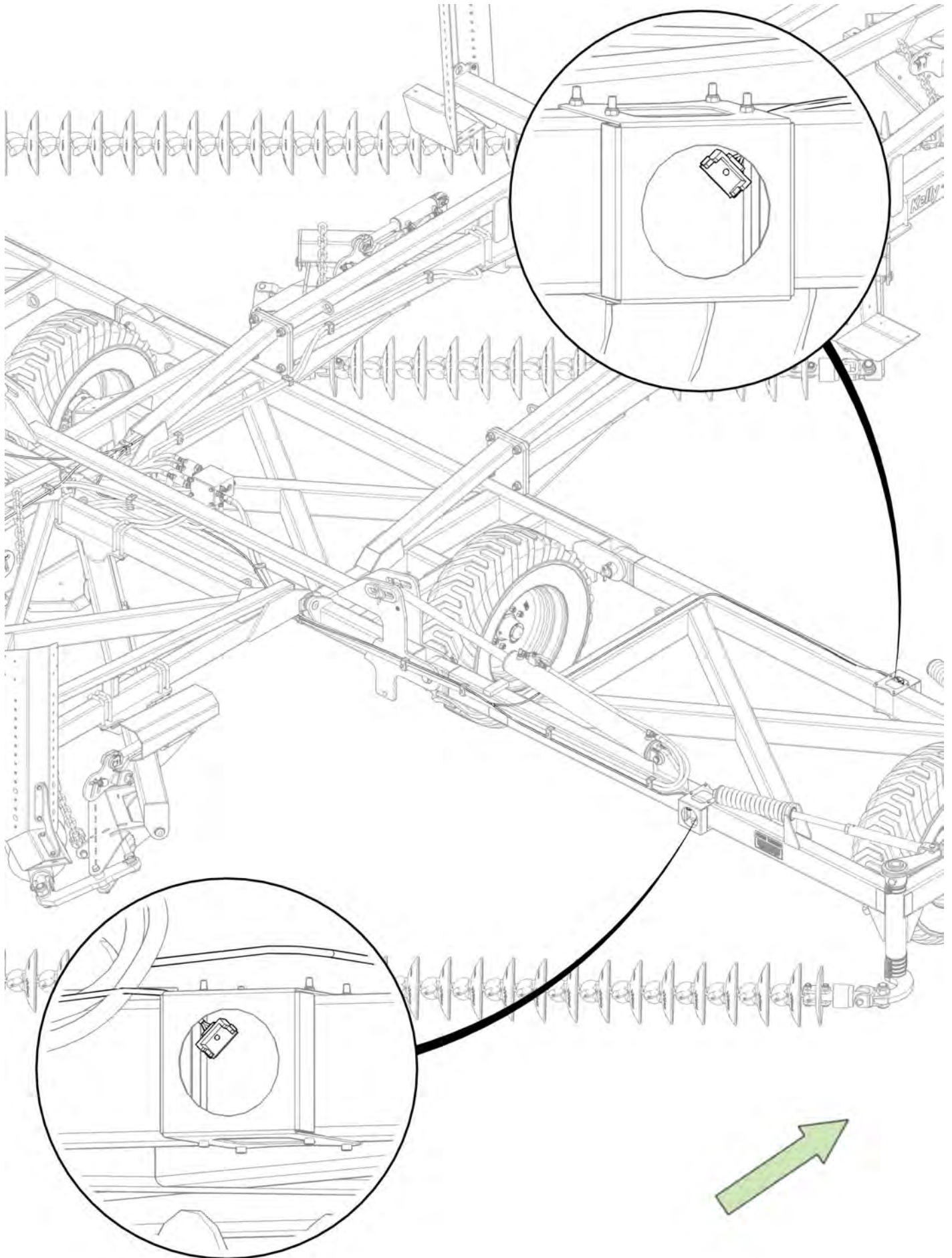

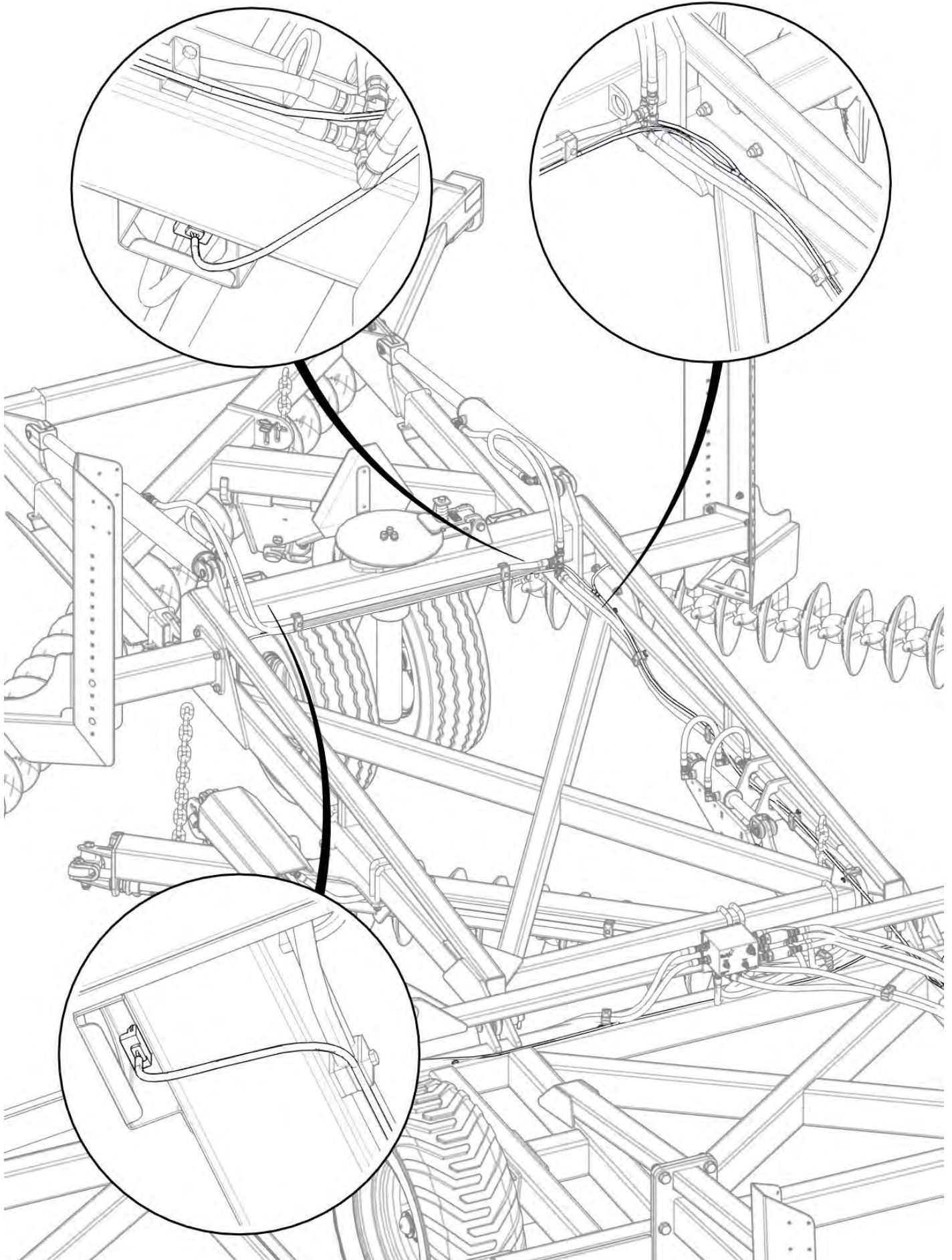



| Item No. | Description             | Number        | Qty |
|----------|-------------------------|---------------|-----|
| 1        | 110RM Rubber Grommet    | 0412-53101RG  | 6   |
| 2        | LED Rear Indicator Lamp | 0412-LED110AM | 4   |
| 3        | LED Stop Tail Lamp      | 0412-LED110RM | 2   |

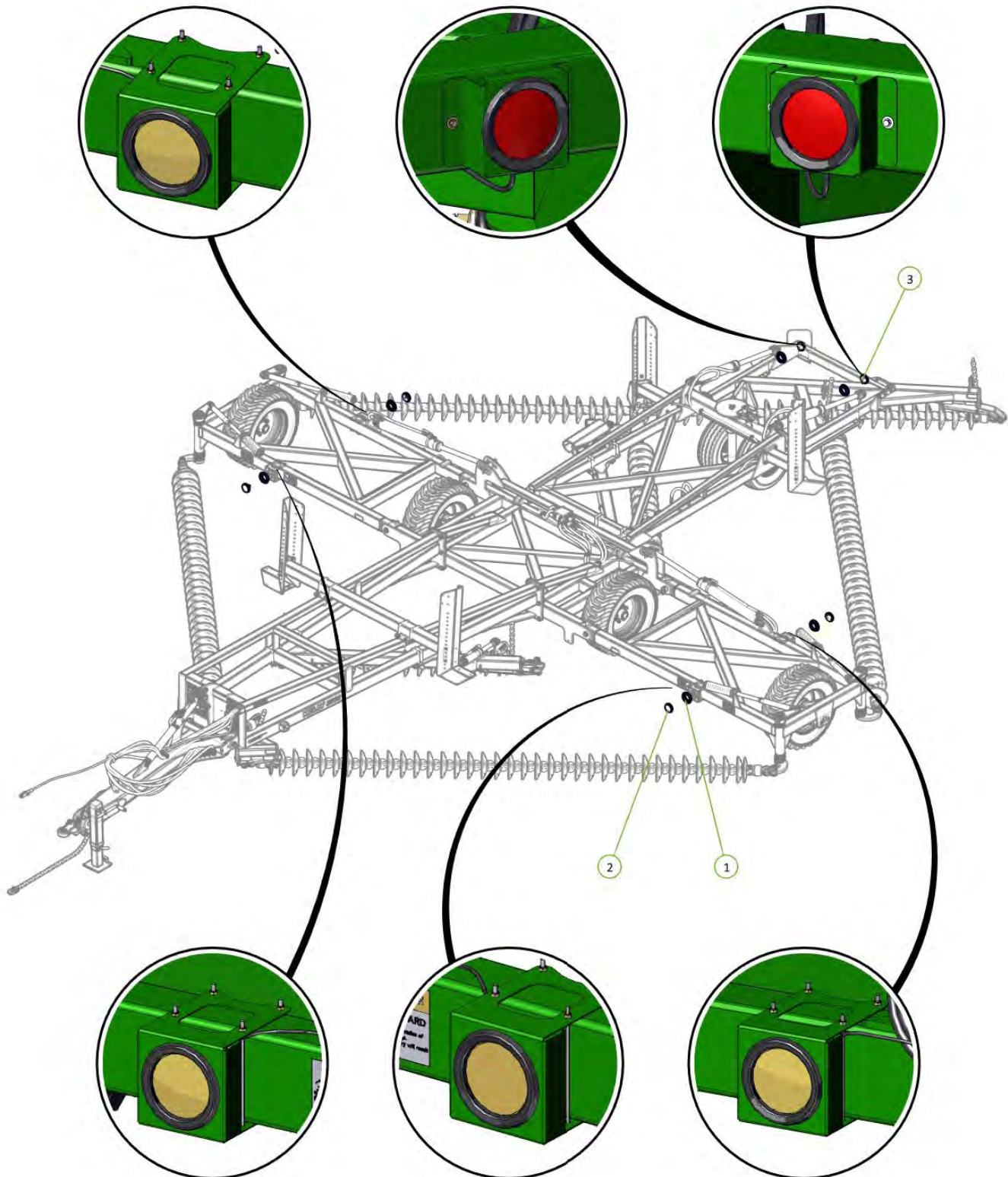
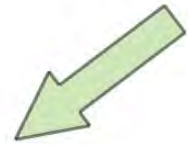





# Section 5 - Chain Assembly

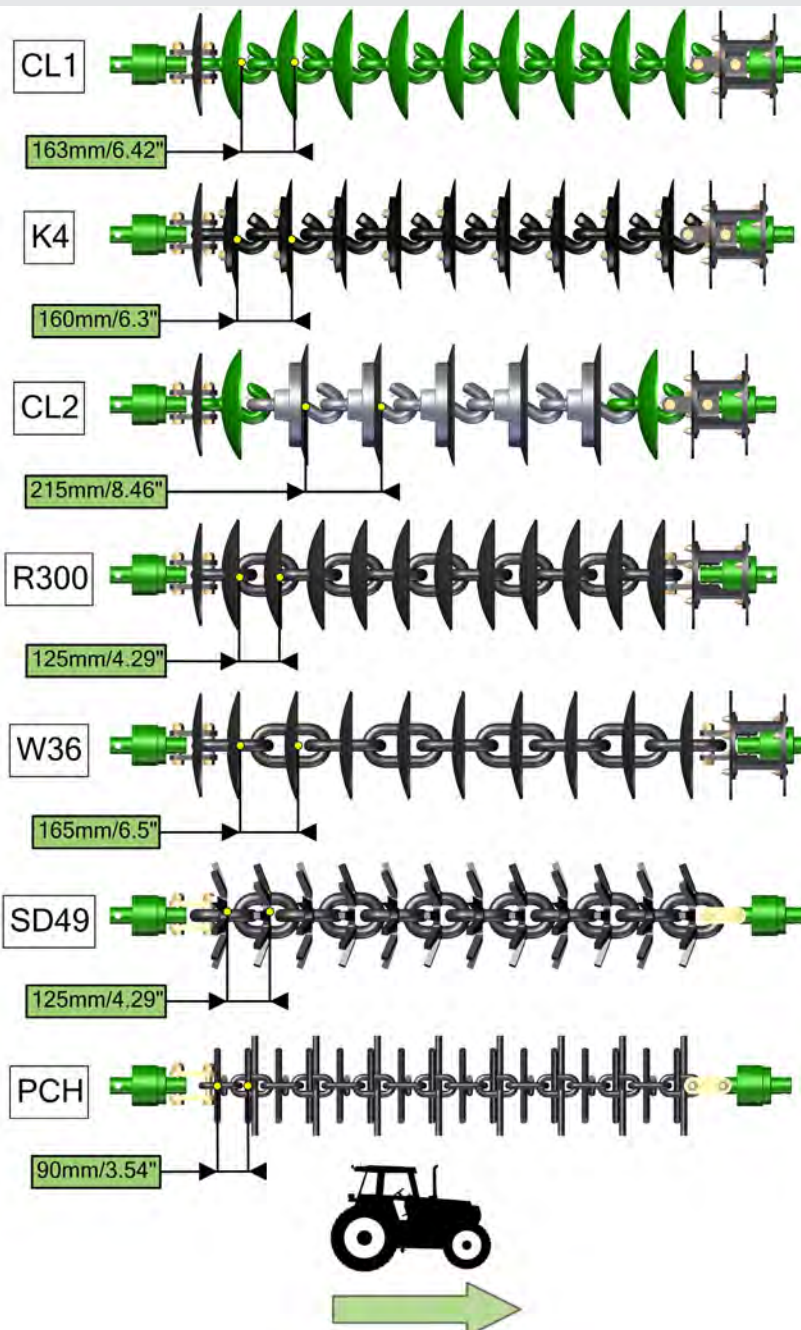

## CL1 Disc Chain

| Item No. | Description                               | Number       |
|----------|---|--------------|
| 1        | Nyloc Nut M20                             | 0221-NYL20   |
| 2        | M20 x 110 Class 10.9 ZP Short Thread Bolt | 0211-20110ST |
| 3        | 20mm Bolt Swivel Unit                     | 0802-PCHB55  |
| 4        | Tie Plate Disc 20mm                       | 0802-DCTP-20 |
| 5        | Disc Chain Spacer                         | 0801-253755  |
| 6        | Roll Pin Zinc Plated 3/8" x 2"            | 0262-3-8X2   |
| 7        | CL1-B Chain Disc Link                     | 0803-CL1     |

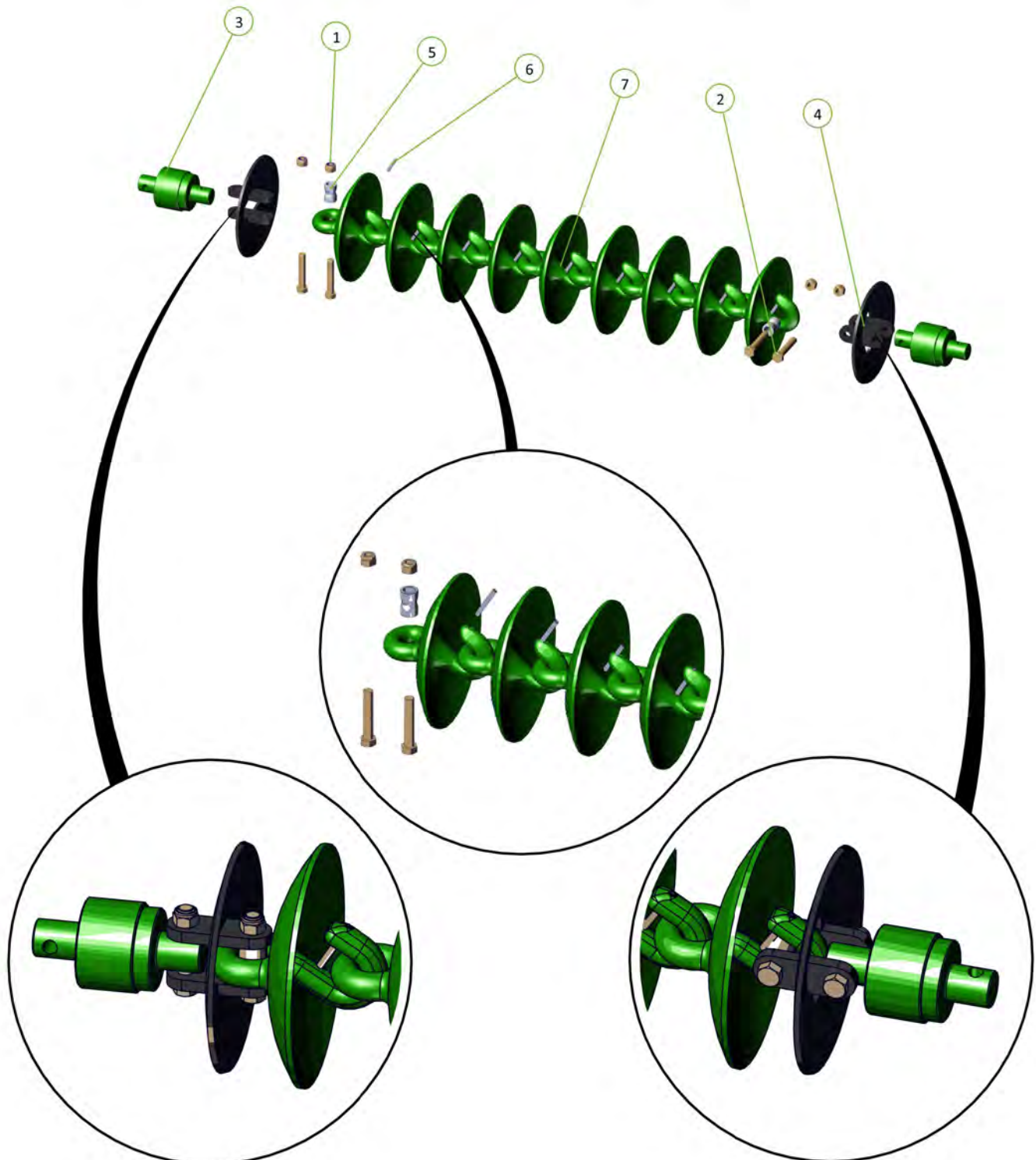

## Fitting Cast Link Pins

Please install cast link retaining Pins (Roll Pin Zinc Plated 3/8" x 2", part number 0262-3-8X2) on all cast disc links.  
Failure to do this could lead to the discs becoming dislodged during transport causing severe damage or injury.

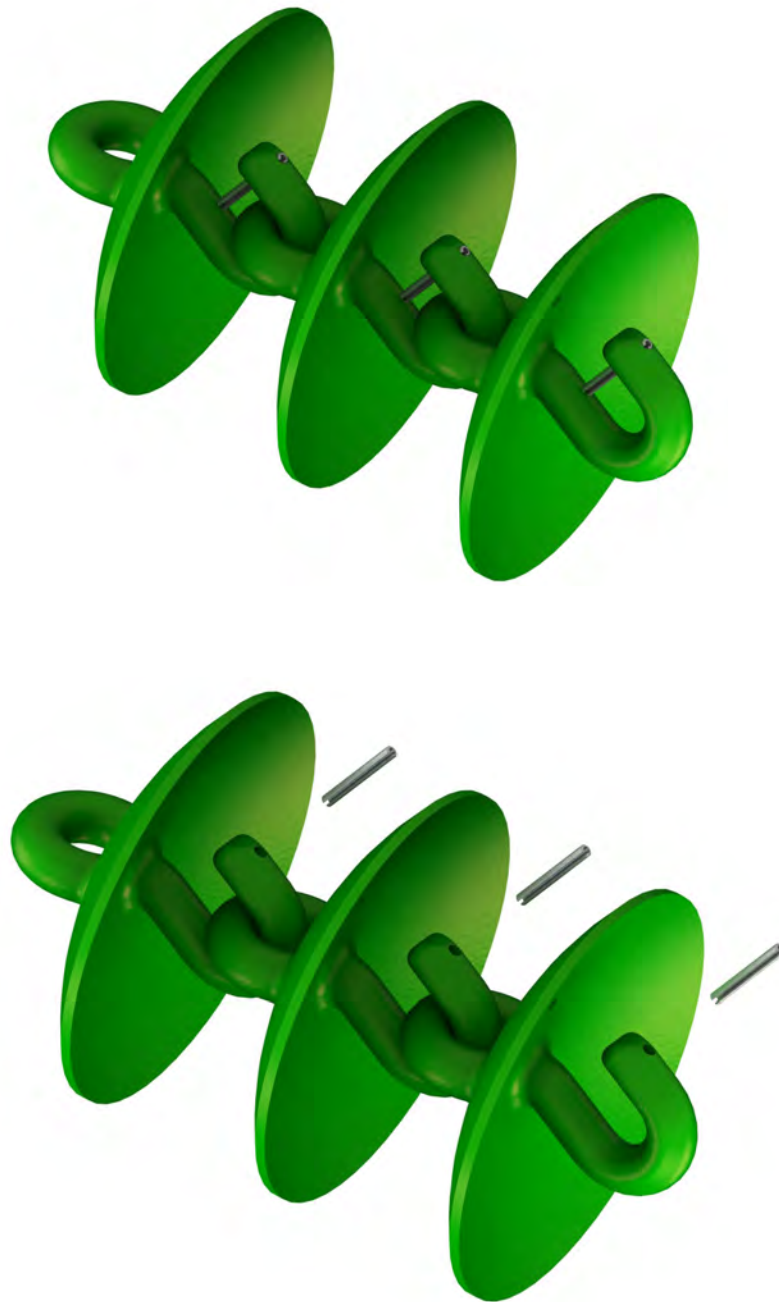



## K4 Disc Chain

| Item No. | Description                               | Number       |
|----------|---|--------------|
| 1        | Nyloc Nut M20                             | 0221-NYL20   |
| 2        | M20 x 110 Class 10.9 ZP Short Thread Bolt | 0211-20110ST |
| 3        | 20mm Bolt Swivel Unit                     | 0802-PCHB55  |
| 4        | Tie Plate Disc 20mm                       | 0802-DCTP-20 |
| 5        | Disc Chain Spacer                         | 0801-253755  |
| 6        | K4 Disc Assembly                          | 0803-K4      |
| 7        | M12 x 55 Class 8.8 ZP Bolt                | 0211-1255    |
| 8        | Nyloc Nut M12                             | 0221-NYL12   |

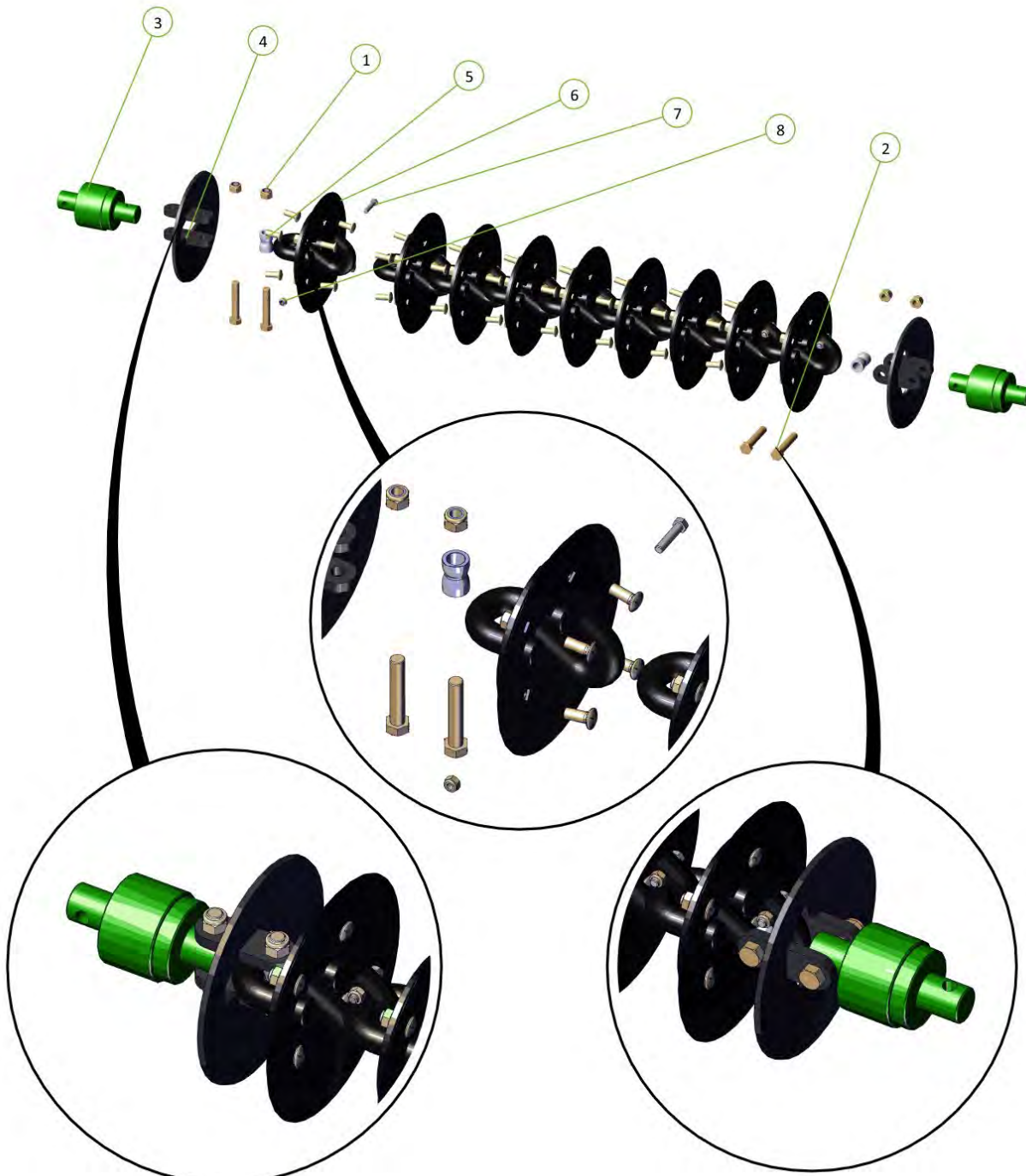

# K4 Weight Assembly on Modules

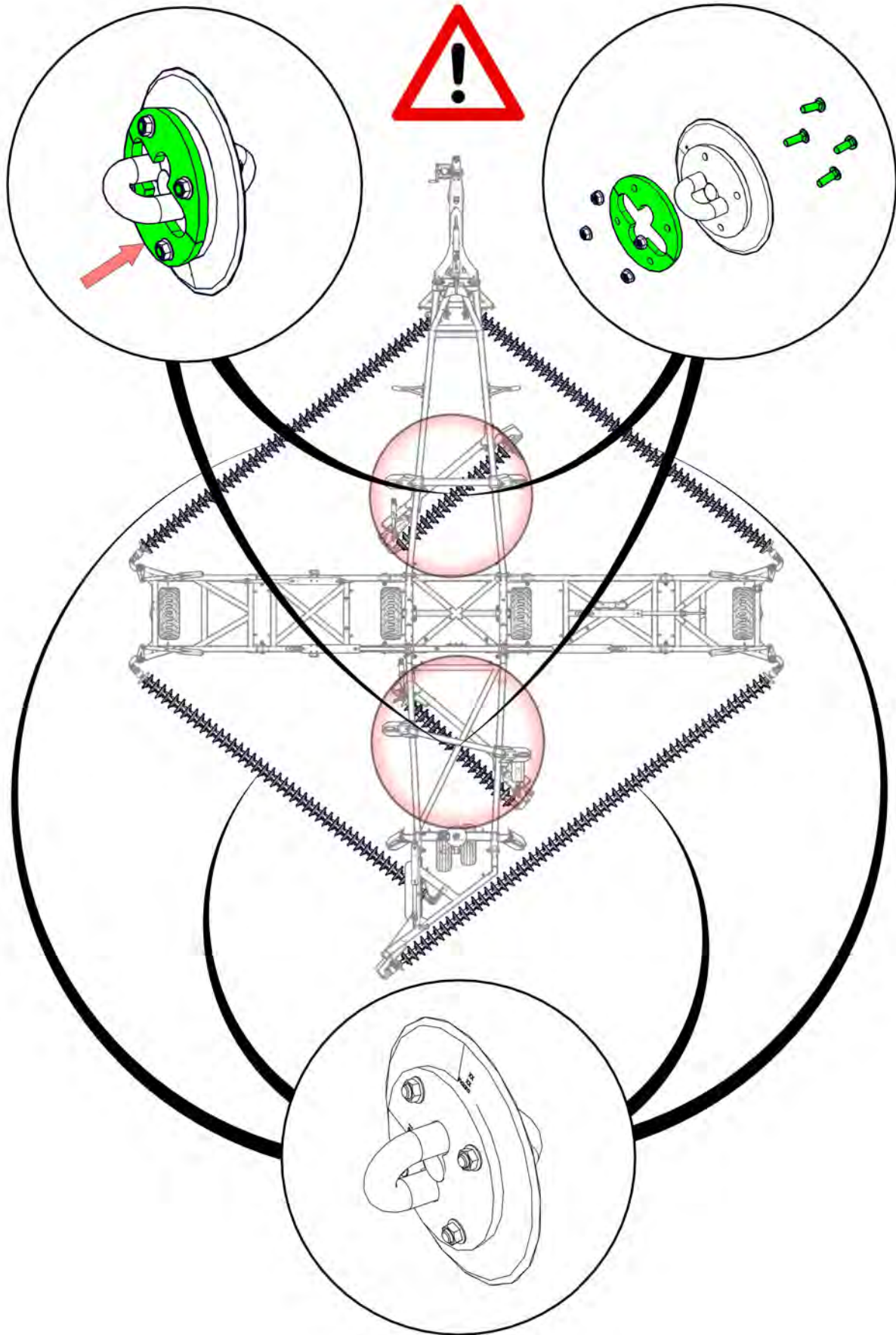

## CL2 Disc Chain

| Item No. | Description                               | Number       |
|----------|---|--------------|
| 1        | Nyloc Nut M20                             | 0221-NYL20   |
| 2        | M20 x 110 Class 10.9 ZP Short Thread Bolt | 0211-20110ST |
| 3        | 20mm Bolt Swivel Unit                     | 0802-PCHB55  |
| 4        | Tie Plate Disc 20mm                       | 0802-DCTP-20 |
| 5        | Disc Chain Spacer                         | 0801-253755  |
| 6        | CL2-Link Assembly                         | 0803-CL2     |
| 7        | Roll Pin Zinc Plated 3/8" x 2"            | 0262-3-8X2   |
| 8        | CL1 Disc Chain Link                       | 0803-CL1     |

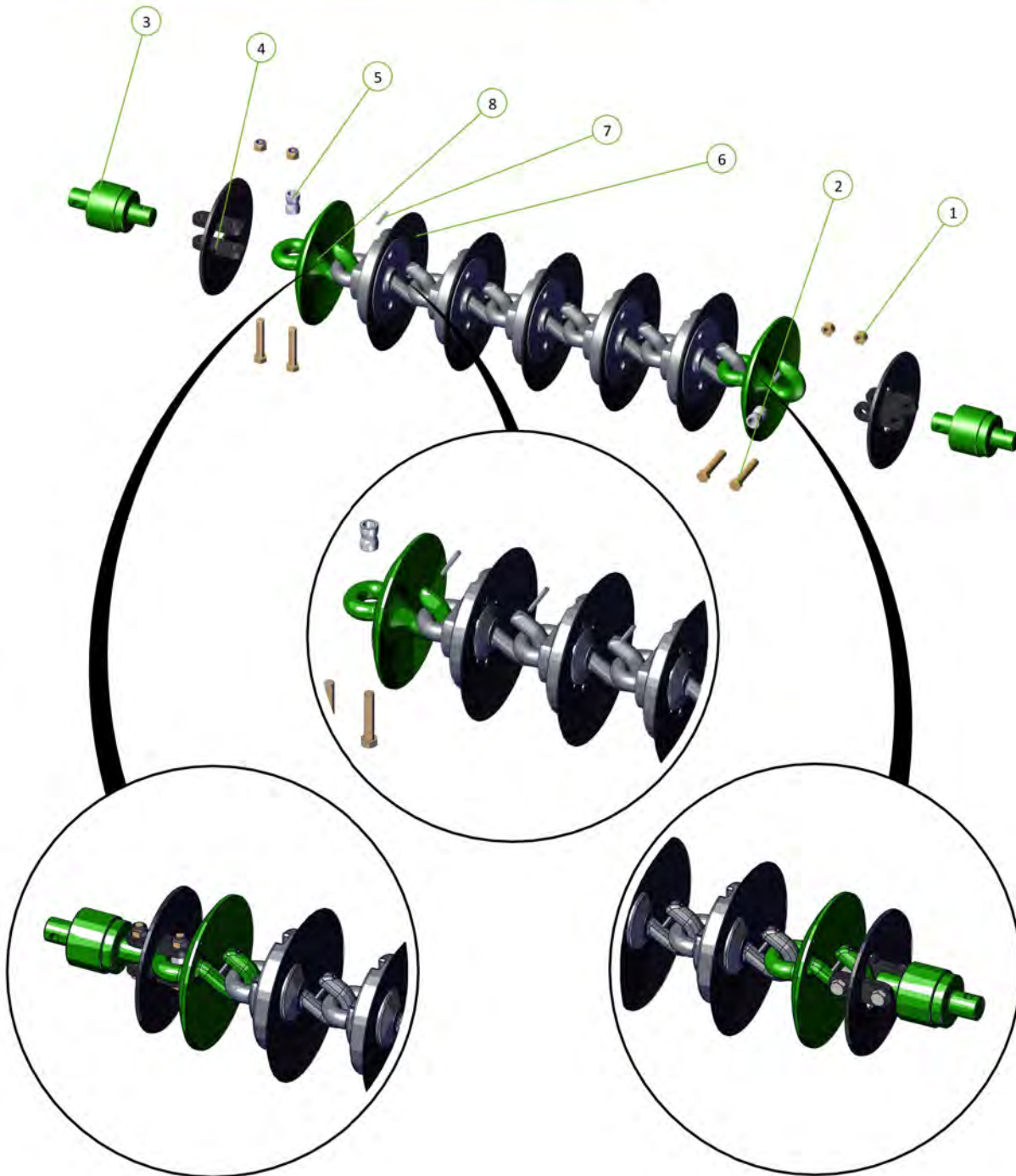



### Recommended CL2 Chain Layout

- CL1 Disc
- CL2 Disc

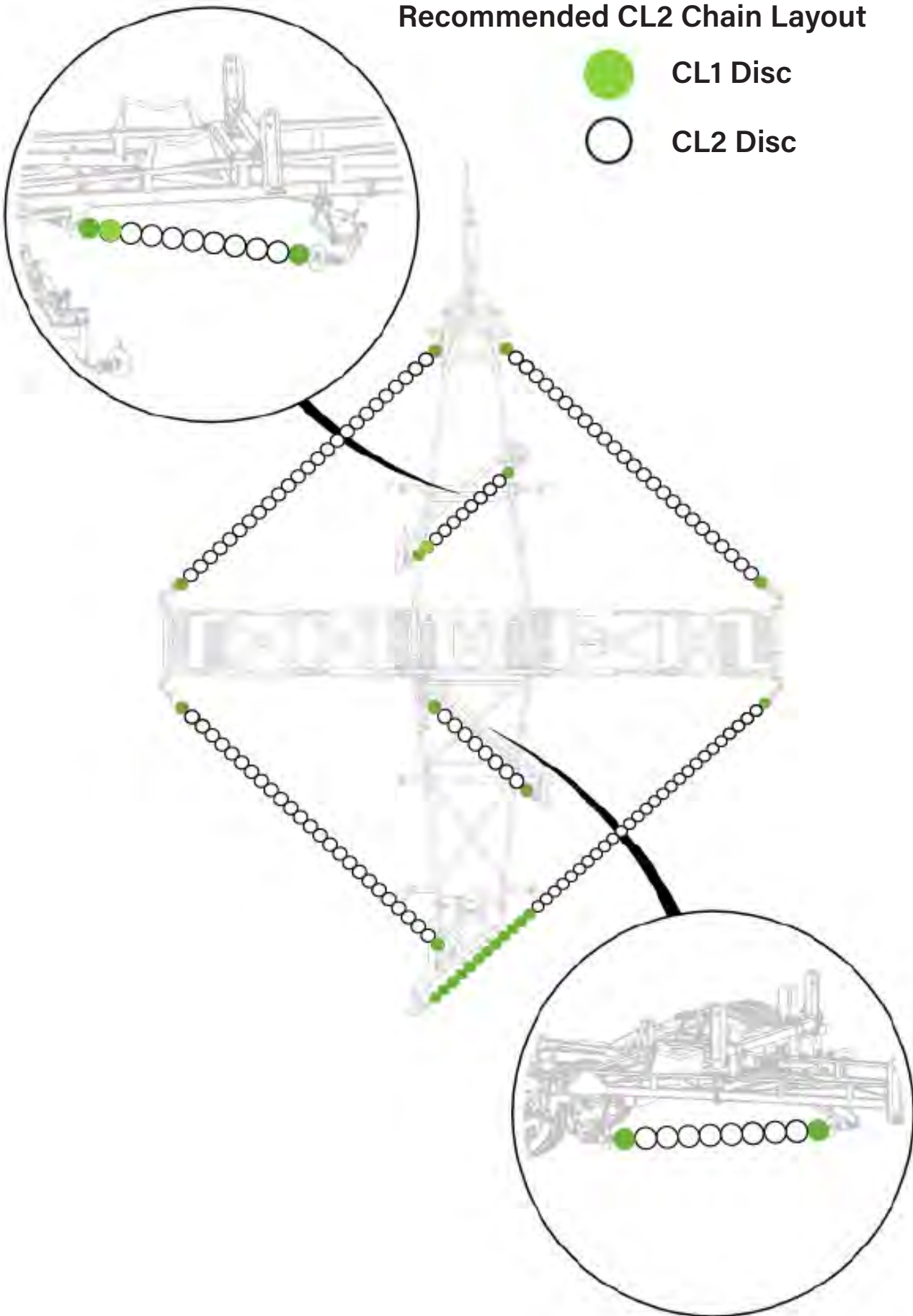

## R300 Disc Chain

| Item No. | Description                               | Number       |
|----------|---|--------------|
| 1        | Nyloc Nut M20                             | 0221-NYL20   |
| 2        | M20 x 110 Class 10.9 ZP Short Thread Bolt | 0211-20110ST |
| 3        | 20mm Bolt Swivel Unit                     | 0802-PCHB55  |
| 4        | Tie Plate Disc 20mm                       | 0802-DCTP-20 |
| 5        | Disc Chain Spacer                         | 0801-253755  |
| 6        | R300 Chain Link                           | 0803-R300    |

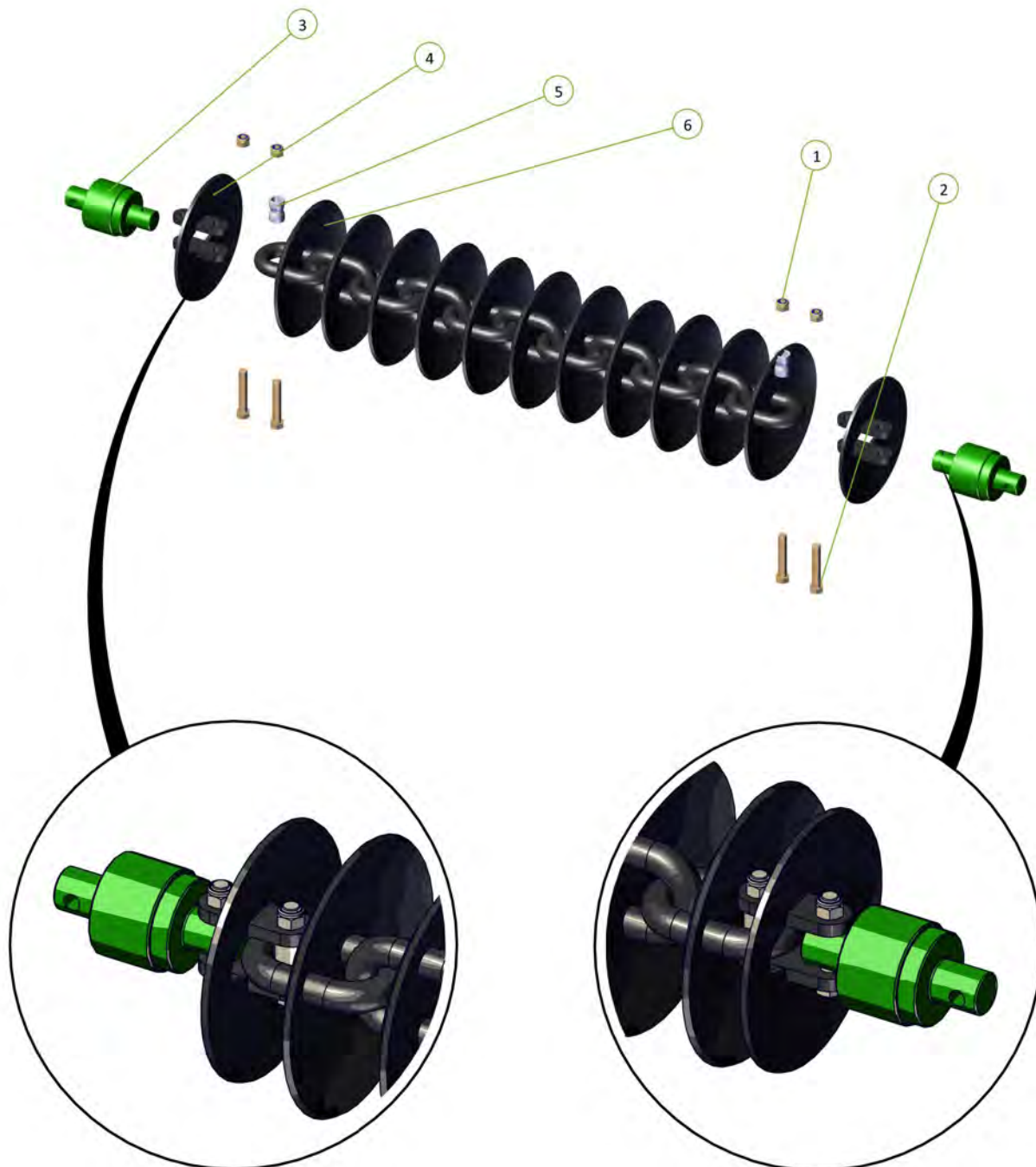
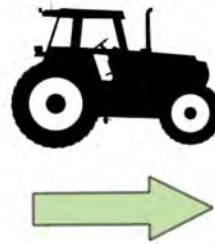

## W36 Disc Chain

| Item No. | Description                               | Number       |
|----------|---|--------------|
| 1        | Nyloc Nut M20                             | 0221-NYL20   |
| 2        | M20 x 110 Class 10.9 ZP Short Thread Bolt | 0211-20110ST |
| 3        | 20mm Bolt Swivel Unit                     | 0802-PCHB55  |
| 4        | Tie Plate Disc 20mm                       | 0802-DCTP-20 |
| 5        | Disc Chain Spacer                         | 0801-253755  |
| 6        | W36/25 Chain Link                         | 0803-W36     |

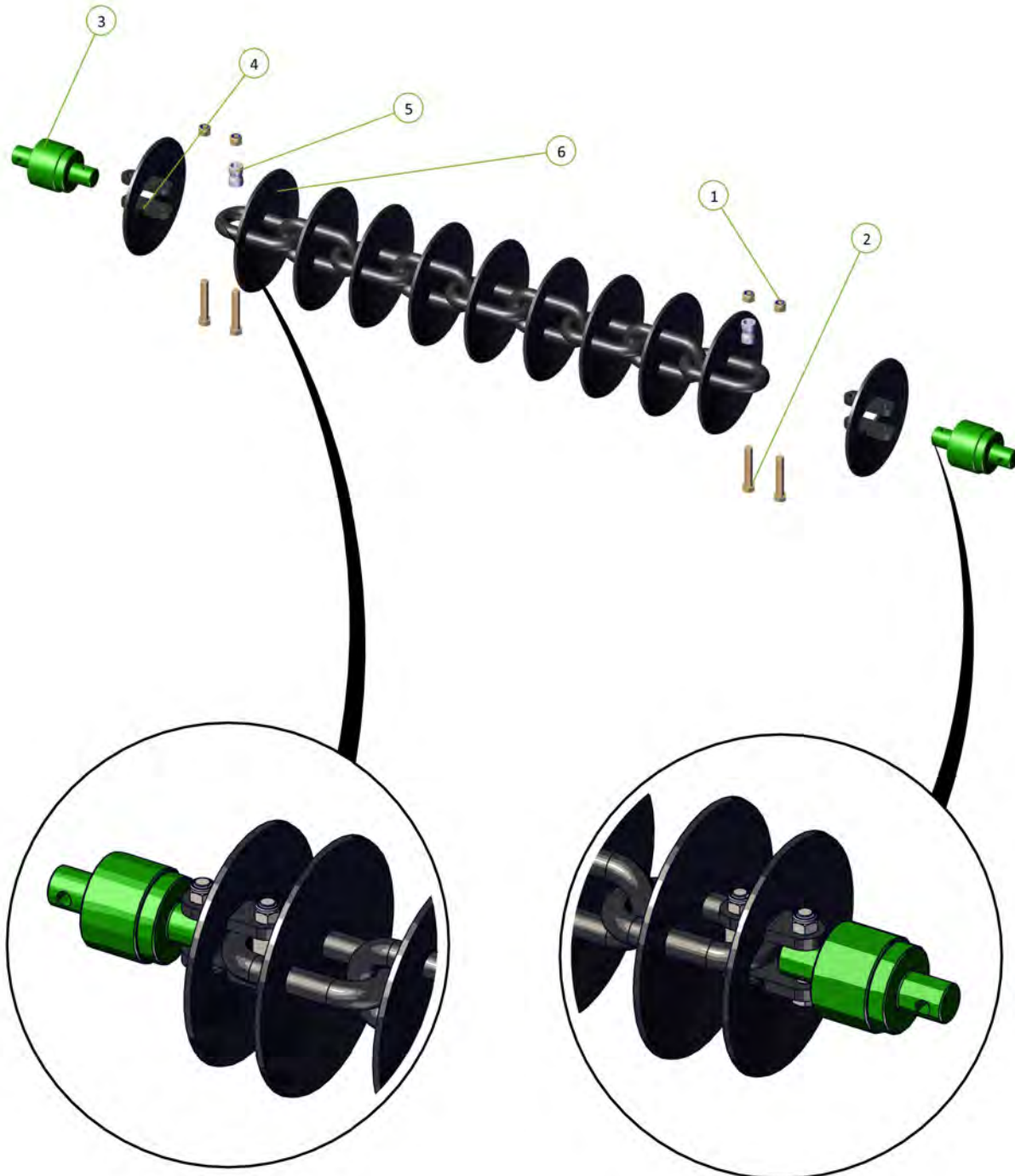



## Spike Disc Chain

| Item No. | Description                               | Number       |
|----------|---|--------------|
| 1        | Nyloc Nut M20                             | 0221-NYL20   |
| 2        | M20 x 110 Class 10.9 ZP Short Thread Bolt | 0211-20110ST |
| 3        | 20mm Bolt Swivel Unit                     | 0802-PCHB55  |
| 4        | Tie Plate For 20mm Bolt                   | 0800-83.2    |
| 5        | Disc Chain Spacer                         | 0801-253755  |
| 6        | 10 Spike Disc Chain 49/27/5               | 0803-SD49    |

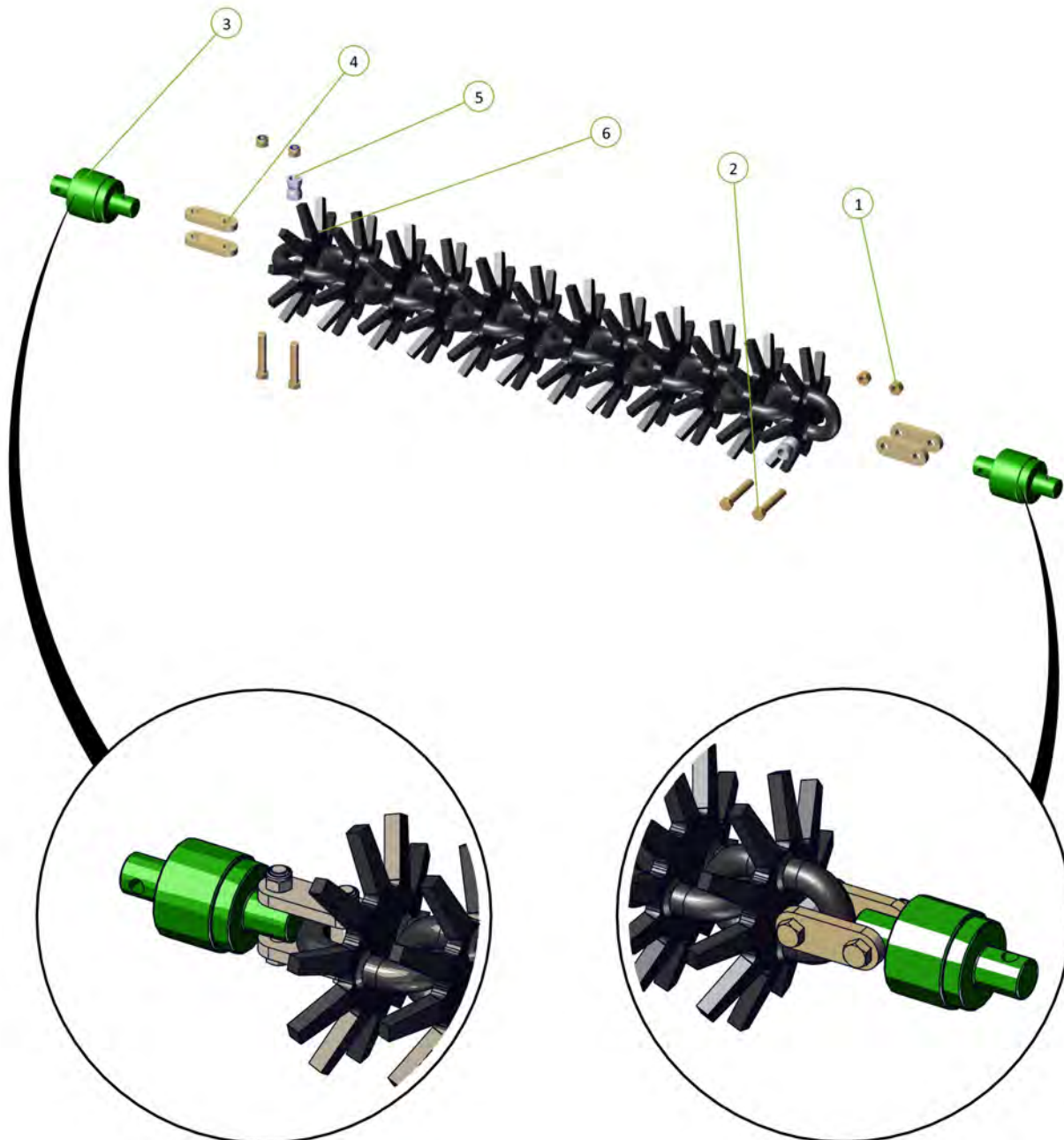

## Prickle Chain

| Item No. | Description                               | Number       |
|----------|---|--------------|
| 1        | Nyloc Nut M20                             | 0221-NYL20   |
| 2        | M20 x 110 Class 10.9 ZP Short Thread Bolt | 0211-20110ST |
| 3        | 20mm Bolt Swivel Unit                     | 0802-PCHB55  |
| 4        | 0800-83.2                                 | 0800-83.2    |
| 5        | Prickle Chain                             | 0803-PCH     |

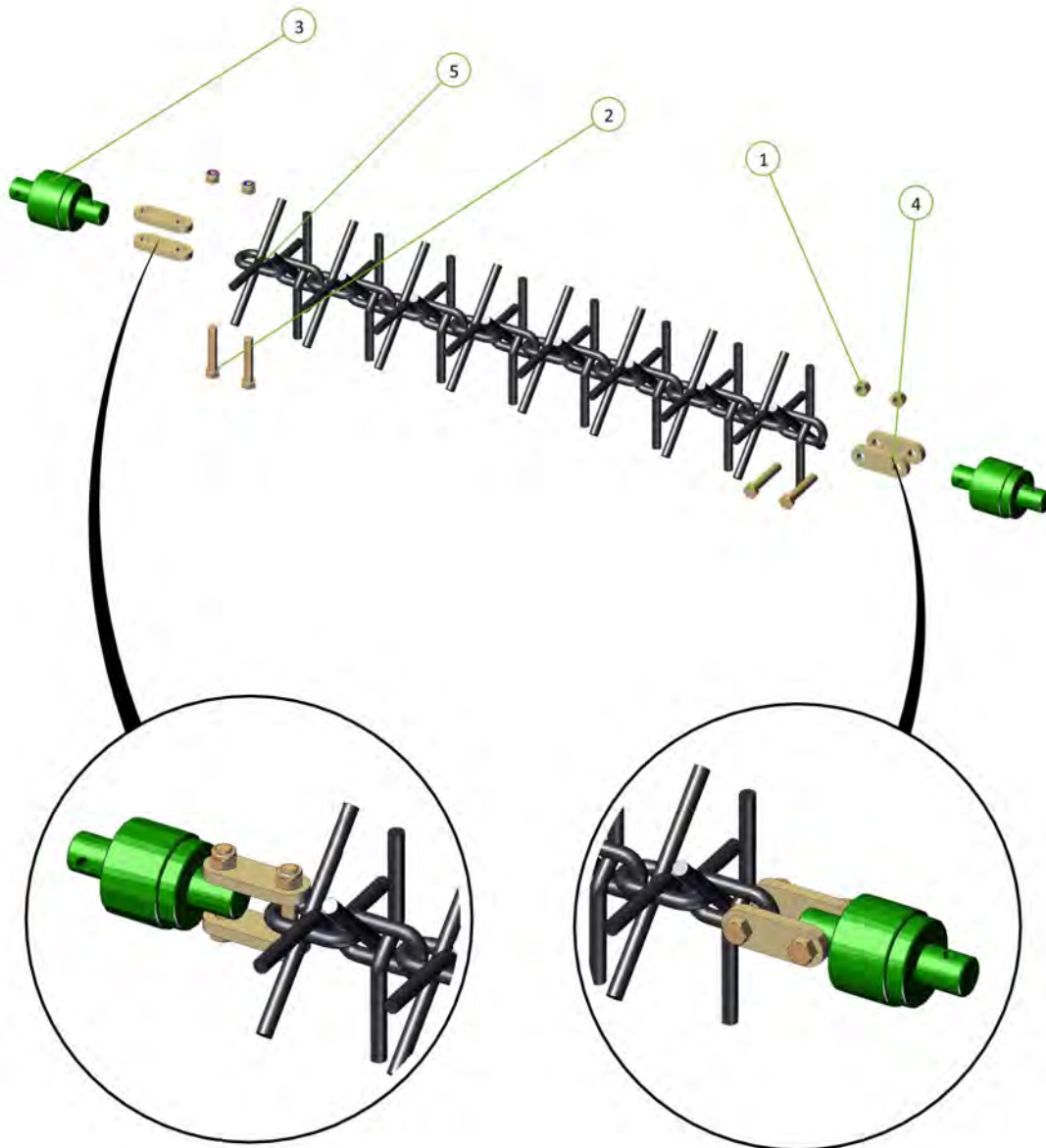
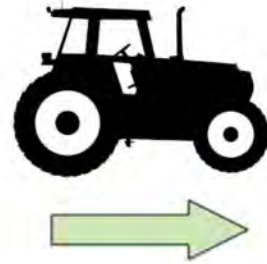



# Section 6 - Specifications

## Wiring Diagram

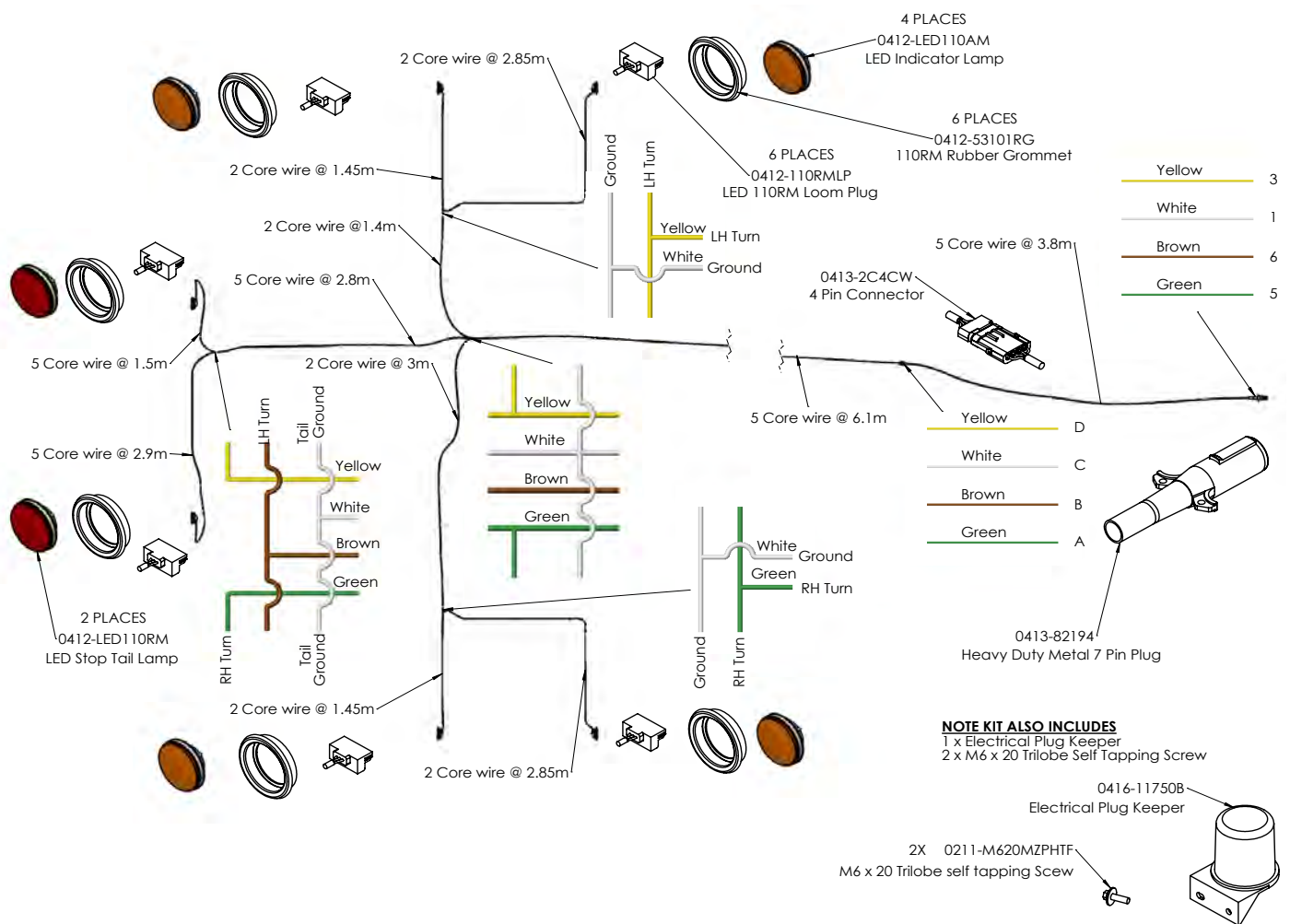

|                     |          |
|---------------------|----------|
| For Machines Built: | Revision |
|                     | B        |



## Operating speeds

| <b>Recommended operating speeds in normal conditions with all chain types</b> |                     |
|---|---------------------|
| Operating and working speeds  | 6-8 mph / 10-12 kph |
| Transporting / towing speed   | 15 mph / 25 kph     |

## Tire pressure

| <b>Tire size</b> | <b>Ply</b> | <b>PSI</b> | <b>KPA</b> |
|------------------|------------|------------|------------|
| 400/55-22.5      | 18         | 50         | 350        |
| 11L/15           | 10         | 44         | 300        |

## 3009 specifications

| <b>Model 3009</b> | <b>All measurements are a guide only and may be +/- 1"</b> |
|-------------------|--|
| Operating width   | 10 m / 33'   |
| Transport width   | 3.5 m / 11' 5"   |
| Transport height  | 4.1 m / 13' 5"   |
| Transport length  | 12.01 m / 39' 5"   |

## Disc Chain Lengths

| Model 3009  |              | Length          | CL2   | CL1 | K4 | W36 | R300 | SD49 | Prickle chain |
|-------------|--------------|-----------------|---|-----|----|-----|------|------|---------------|
|             |              |                 | CL2 disc chain also requires CL1 disc chain |     |    |     |      |      |               |
| <b>3009</b> | Front right  | 18' 9.59"/5.73m | CL2 - 25<br>CL1 - 2                         | 35  | 36 | 34  | 46   | 46   | 64            |
|             | Front left   | 18' 9.98"/5.74m | CL2 - 25<br>CL1 - 2                         | 35  | 36 | 34  | 46   | 46   | 64            |
|             | Rear right   | 25' 9.45"/7.86m | CL2 - 27<br>CL1 - 13                        | 48  | 50 | 46  | 63   | 63   | 87            |
|             | Rear left    | 19' 0.35"/5.8m  | CL2 - 25<br>CL1 - 2                         | 35  | 37 | 34  | 46   | 46   | 64            |
|             | Front Module | 7' 8.52"/2.35m  | CL2 - 9<br>CL1 - 3                          | 14  | 15 | 14  | 19   | 19   | 26            |
|             | Rear Module  | 6' 7.92"/2.03m  | CL2 - 8<br>CL1 - 2                          | 12  | 13 | 12  | 16   | 16   | 22            |

For correct chain tension, chain links may need to be removed from the end of the chain as follows:

CL2 Disc Chain - unhook disc chain link/s from end of the disc chain

K4 Disc Chain - unhook disc chain link/s from end of the disc chain

CL1 Disc Chain - unhook disc chain link/s from end of the disc chain

SD49 Disc Chain - cut a disc chain link from the end of the disc chain

W36 Disc Chain - cut a disc chain link from the end of the disc chain

Prickle Chain - cut a prickle chain link from the end of the prickle chain

R300 Disc Chain - cut a disc chain link from the end of the disc chain

This QR code will take you to a short video on how to remove welded chain links





# Section 7 - Operation

## Basic Operation

### Unfolding:

1. Walk around and inspect the machine.
  - a. Check that chains are not hooked on framework
  - b. Check swivel units are in place and not broken
  - c. Check that height adjusting chains have not fallen out of their slotted plates during transport.
  - d. Ensure front lift cylinder depth stops are fully engaged on cylinder shaft.
2. Lower front A frame to working height.
3. Unfold wings holding the hydraulic lever until both the main center cylinder pins have centered in their slots. (If chain pulls tight during unfold, stop and inspect if chain is hooked)
4. Lower rear tail by holding hydraulic lever until tail and modules are completely lowered to working position.
5. Walk around and check that all chain links are straight and that working height of all swivels is correct for field conditions. Adjust if necessary.
6. Move off with all chains in working position. If necessary it is acceptable to raise front A frame to transport height. This will lift the front chains off the ground and reduce the load on the tractor. Lower the front A frame once moving satisfactorily.

### Folding:

1. Lower the front A frame at working height. (This is important to ensure that all chains locate correctly in their transport rests).
2. Raise the Rear Tail and modules by holding the hydraulic lever until they come to a complete stop.
3. Fold the wings. They should move as follows; main center cylinders will retract, one or both, until the wings stand vertically. The left outer wing then the right outer wing will fold down.
4. Raise front A frame to transport height.
5. Walk around and check that chains have located correctly in transport rests.



## Chain Tension - Wings

- Use the spanner supplied to loosen the lock nut adjacent to the tensioner assembly body.
- Turn the module tension rod clockwise to compress the coil spring to 330mm. Correct tension is achieved when spring retains its set length when operator rolls the chain fore and aft on the ground.
- Retighten the lock nut.
- When less than 25mm of thread remains visible on the adjustor bolt then a link must be removed from the chain.

## Spring Compression Length

| Model | inches | mm  |
|-------|--------|-----|
| 3009  | 12.9   | 330 |

When less than 4" (100mm) of thread remains visible on the adjustor bolt then a link must be removed from the chain

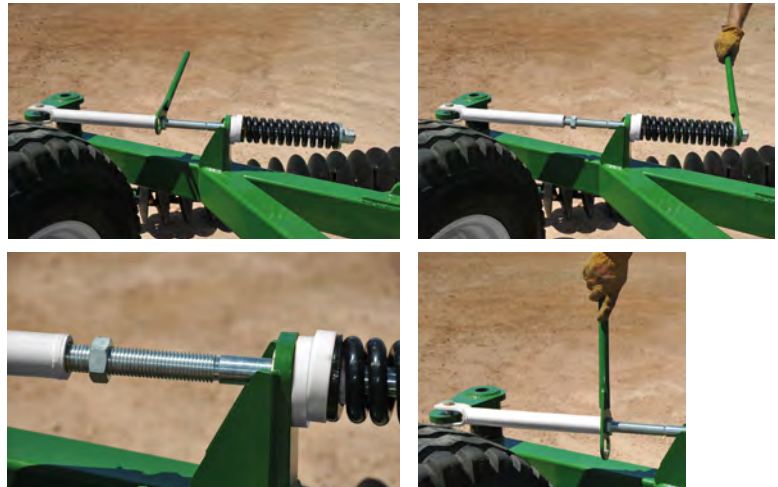

## Chain Tension - Modules

1. Loosen the lock nut on the draw bolt.
2. Tighten the adjusting nut clockwise until the outer face of the spring retaining washer is pushed with the body of the module tensioning unit.
3. When 7-7/8" / 200mm or more of tensioner thread is visible then one link must be removed from the chain set to maintain correct tension adjustment. Spring length of 330mm / 1' 1" .
4. Retighten the lock nut.



## Importance of chain tension

### Operational

Chain tension is critical to achieve a smooth and level seedbed. A correctly tensioned, monitored and maintained chain will deliver the results you need. Incorrect chain tension can lead to:

- Uneven results across the cut width of the machine
- Uneven weed control
- Unsatisfactory incorporation
- Ineffective levelling
- Accelerated or premature chain link wear (not covered by warranty)
- Chains failing to engage with transport locator's when folded
- Machine damage when folding or unfolding
- Uneven field surface with ridges and furrows being created.

**A correctly adjusted machine will not cause this problem.**

## Correct Chain Height Adjustment

To adjust the swivel height at the wings, relocate one of the spacers either above or below the fixed mounting tube. Each Dropleg has four pairs of 25mm cast spacers. The most common set up is to have two pairs of cast spacers on the bottom and two pairs of cast spacers on the top. Below is the process to adjust the Dropleg height.

|   |   |
|---|---|
| 1 | Loosen chain tension completely   |
| 2 | Undo 2 x M10 bolts from corresponding spacer set and take the two halves off of the drop leg tube |
| 3 | Replace it in the selected position after raising or lowering the drop leg                        |
| 4 | Reinstall the M10 bolts and re-tension the chain  |

It is possible to install all spacers either above or below the mounting tube giving a maximum of 4" (100mm) of adjustment.

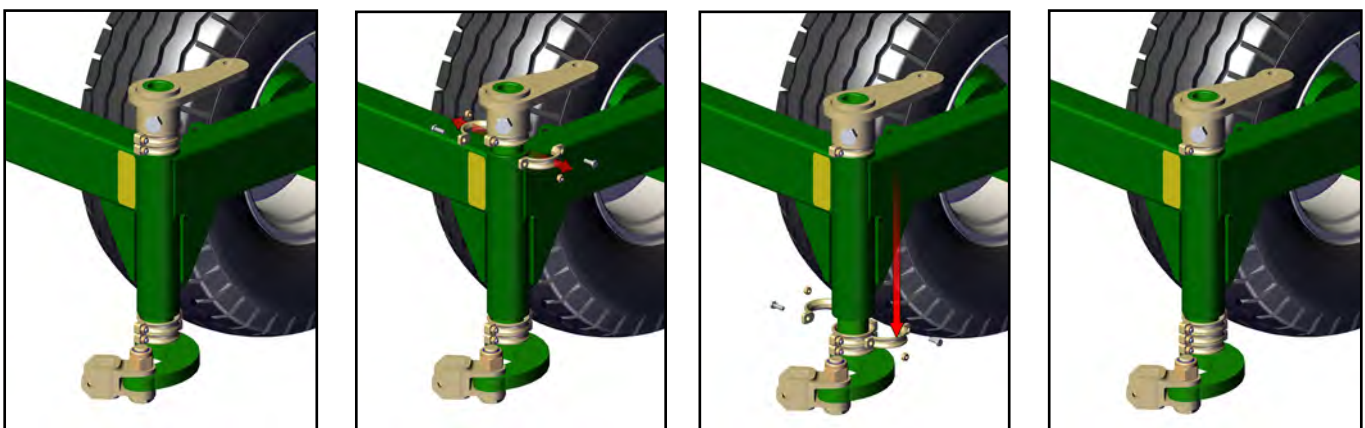









Phone +61 8 8667 2253  
Email [sales@kellytillage.com](mailto:sales@kellytillage.com)  
[kellytillage.com](http://kellytillage.com)

**Booleroo (Head Office)**  
684 Kelly Road,  
Booleroo Centre SA 5482

**Adelaide Office**  
28 Greenhill Road,  
Wayville SA 5034

