

Kelly

Smoother

Kelly Smoother Assembly & Parts Manual

For serial numbers > KS-115004
For machine built after 01/07/2017

Revision D - February 2017

Machine Serial Number:



Kelly Engineering
PO Box 100
Boileroo Centre
South Australia 5482
P +61 8 8667 2253
F +61 8 8667 2250
W kellyengineering.com.au

Thank you for choosing a Kelly Engineering product

We trust that you find the following manual clear and easy to follow. If you should require additional customer support or assistance, please do not hesitate to contact us.

Spare parts can be purchased, as required, through your local dealer or by contacting Kelly Engineering Australia or in the United States, Hood & Company.

Kelly Engineering welcomes feedback. Should you have any difficulties that you wish to raise, suggestions for improvement or modifications that you feel would enhance our products we look forward to hearing from you.

Australia

Kelly Engineering

PO Box 100

Boomeroo Centre SA 5482

Phone: + 61 8 8667 2253

Fax: + 61 8 8667 2250

Email: sales@kellyengineering.com.au

Spare Parts: parts@kellyengineering.com.au

Website: www.kellyengineering.com.au

United States

Kelly Engineering

Website: www.kellyharrows.com

Spare Parts

Hood & Company Inc

Springfield MO

Phone: 417 865 2100

Fax: 417 865 2105

Email: hoodco@hoodco.com

Contents

	Page no
Section 1: Unpacking	4
Section 2: Assembly	6
Section 3: Hydraulics Setup	89
Section 4: Electrical Setup	89
Section 5: Decal Placement	131
Section 6: Operation	138
Specifications	
Chain tension	

Section 1

Unpacking

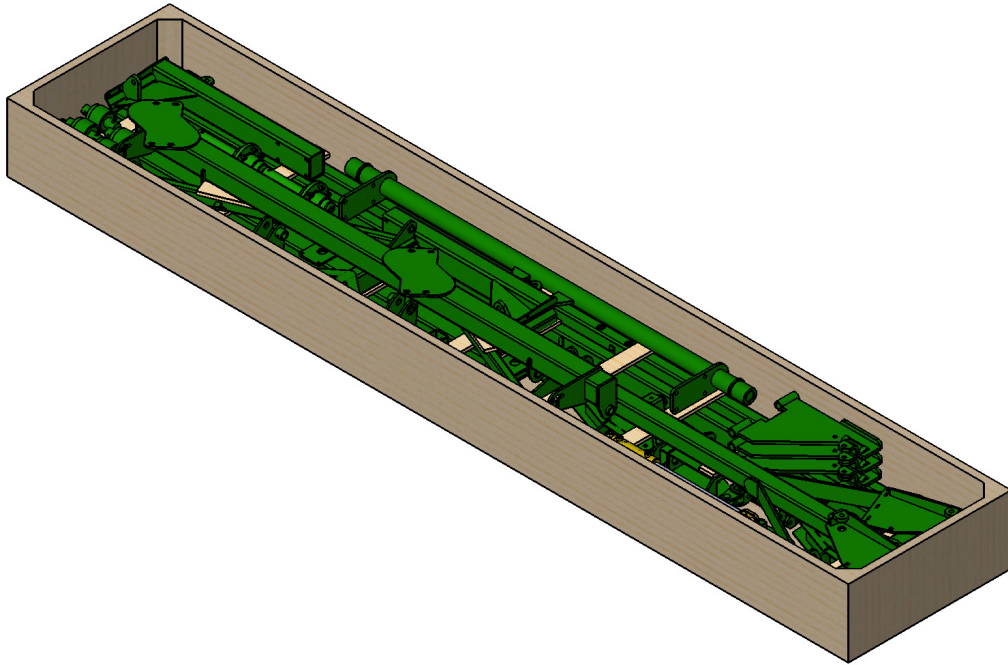

Caution

- Use appropriate lifting equipment to unpack frame work from crate
- Once all parts have been identified machine is ready for assembly
- Read assembly instructions before proceeding

Section 2

Parts & Assembly

Step 1: Place the two side rails on suitable stands (approximately 800 - 900mm (2' 6" - 3') High and with a SWL of at least 500kg (1000Lb)) as shown below

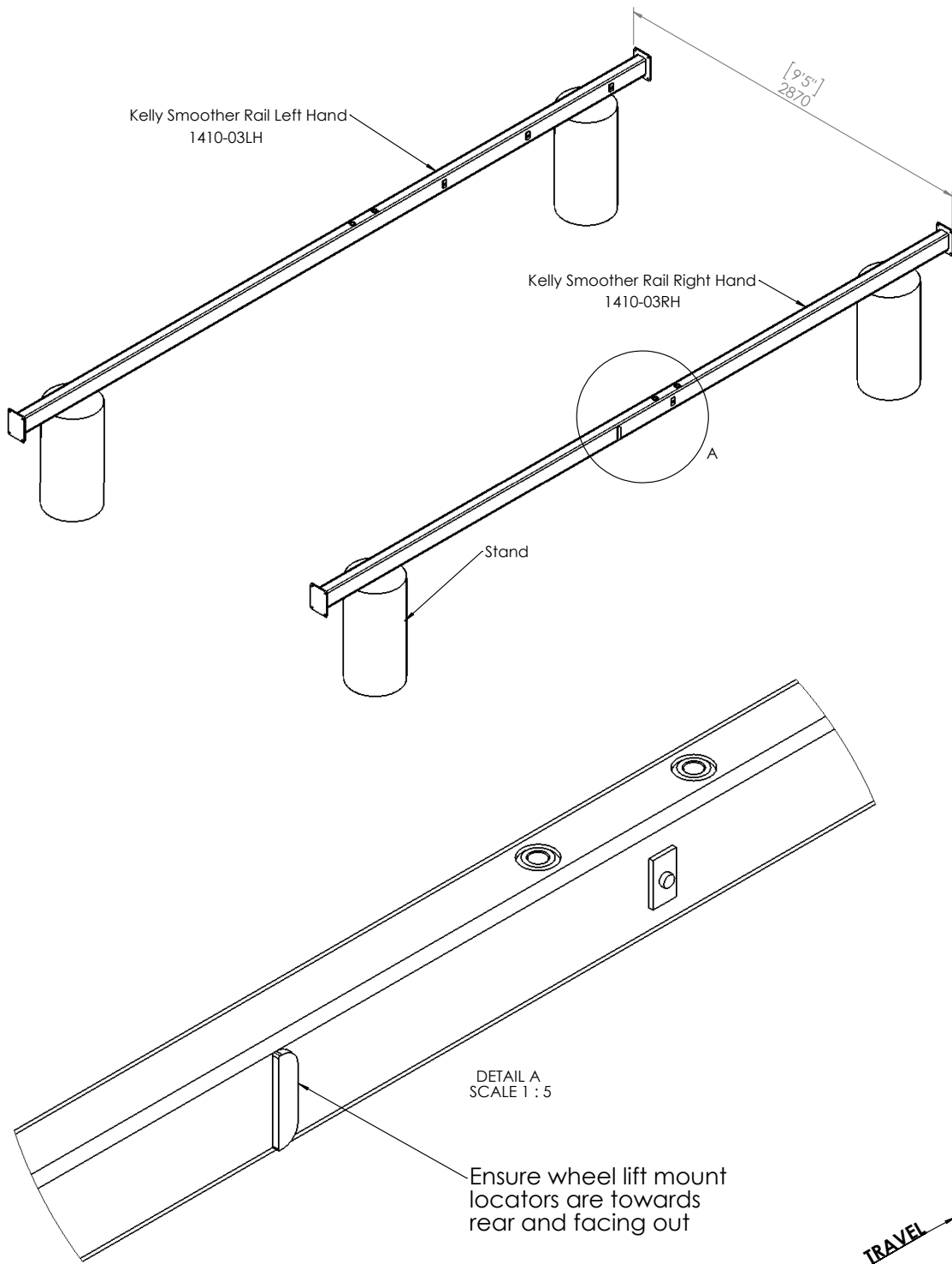

Step 2: Using appropriate lifting equipment lift the front and rear frames into position and attach with the supplied bolts. Leaving the bolts loose until the centre rail is in place (next step).

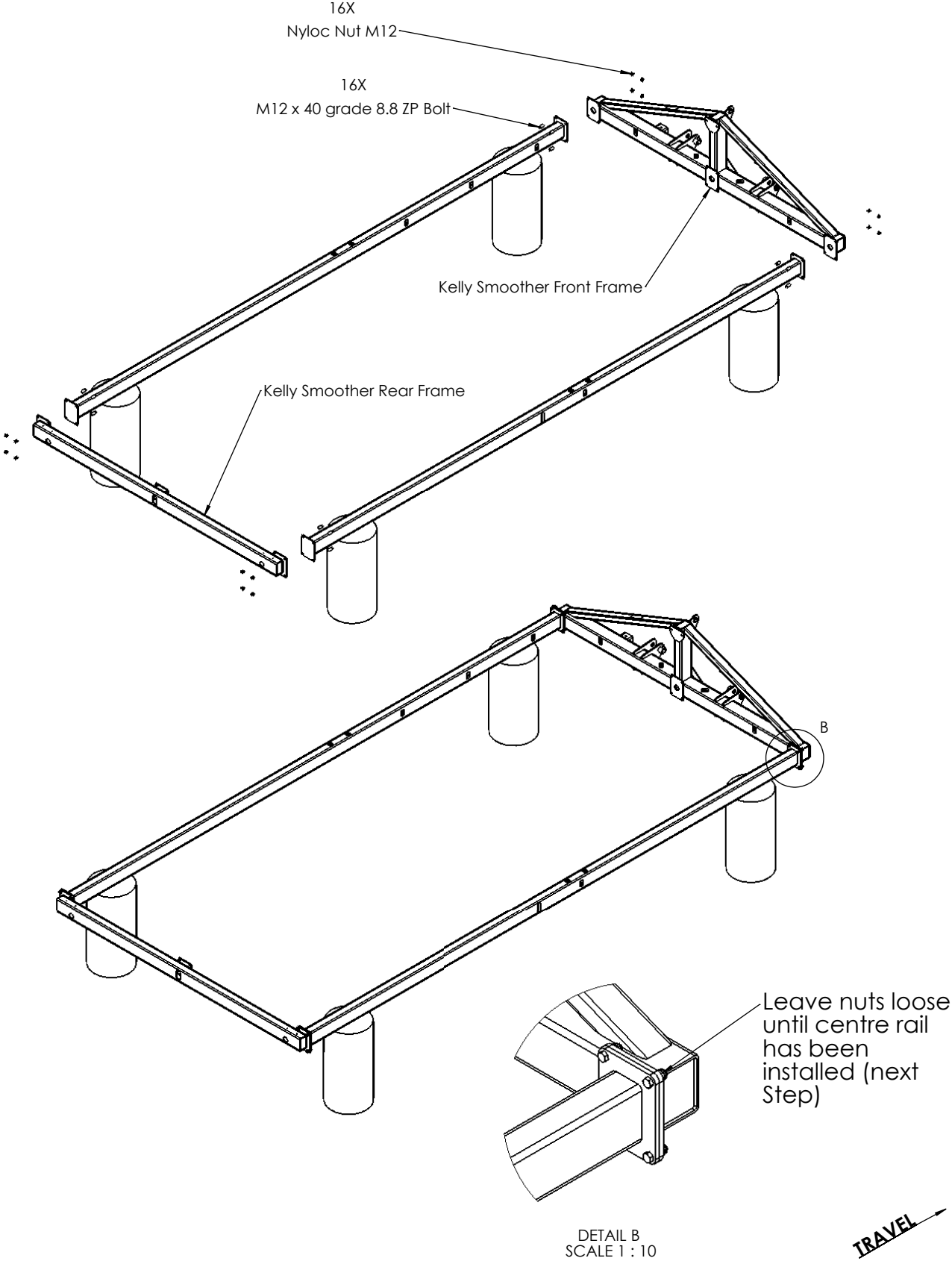

Step 3: Using appropriate lifting equipment lift the centre rail into position and attach with the supplied bolts. For machines supplied with a light kit a draw wire is supplied and installed through the centre or the centre rail, draw this wire through the attaching plates to allow drawing the light kit cable through later.

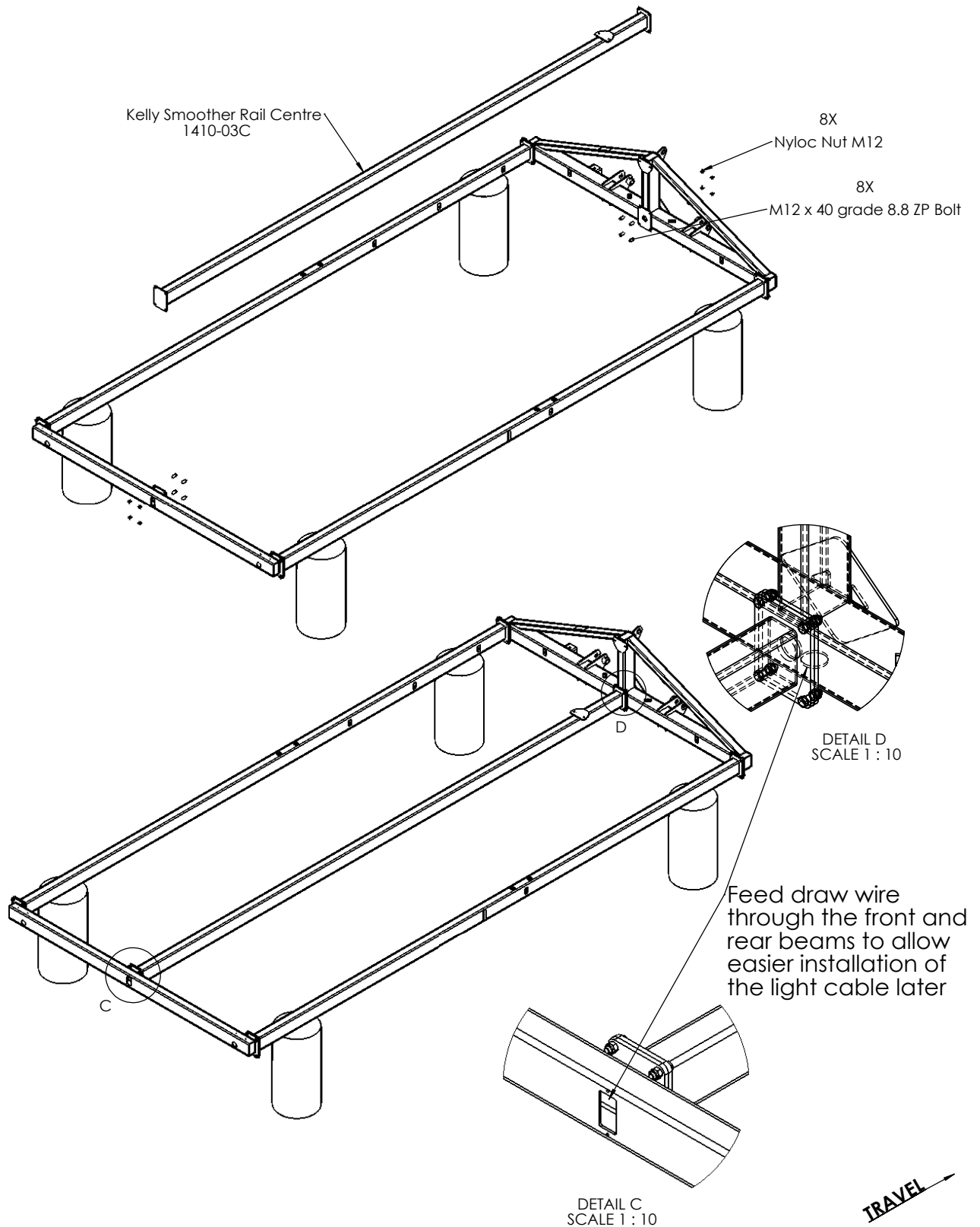

Step 4: Position the front post brace bar in place and attach with the supplied bolts.

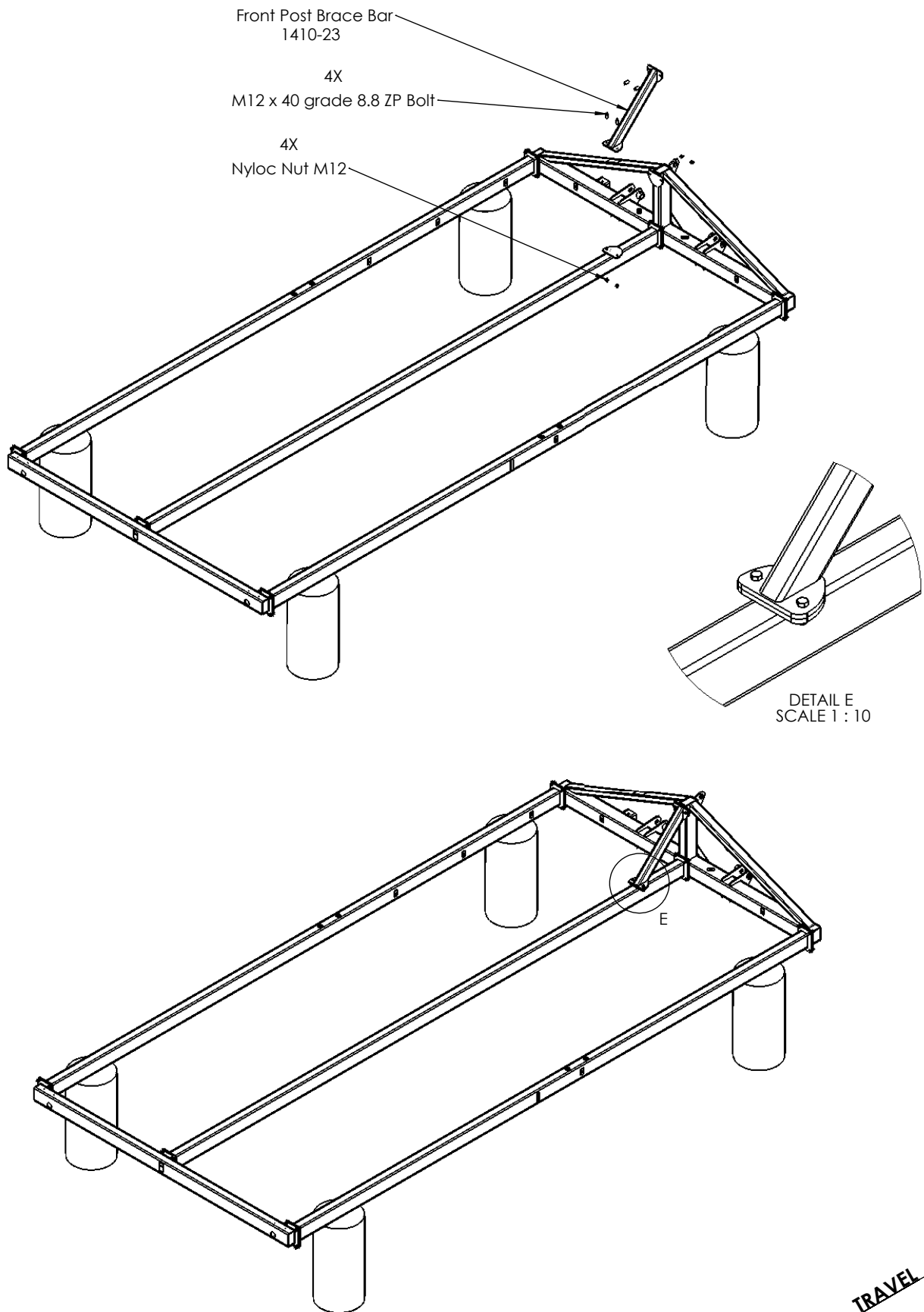

Step 5: Using the supplied self tapping bolts and loop pin attach the operator manual canister and the chain adjusting gear wrench.

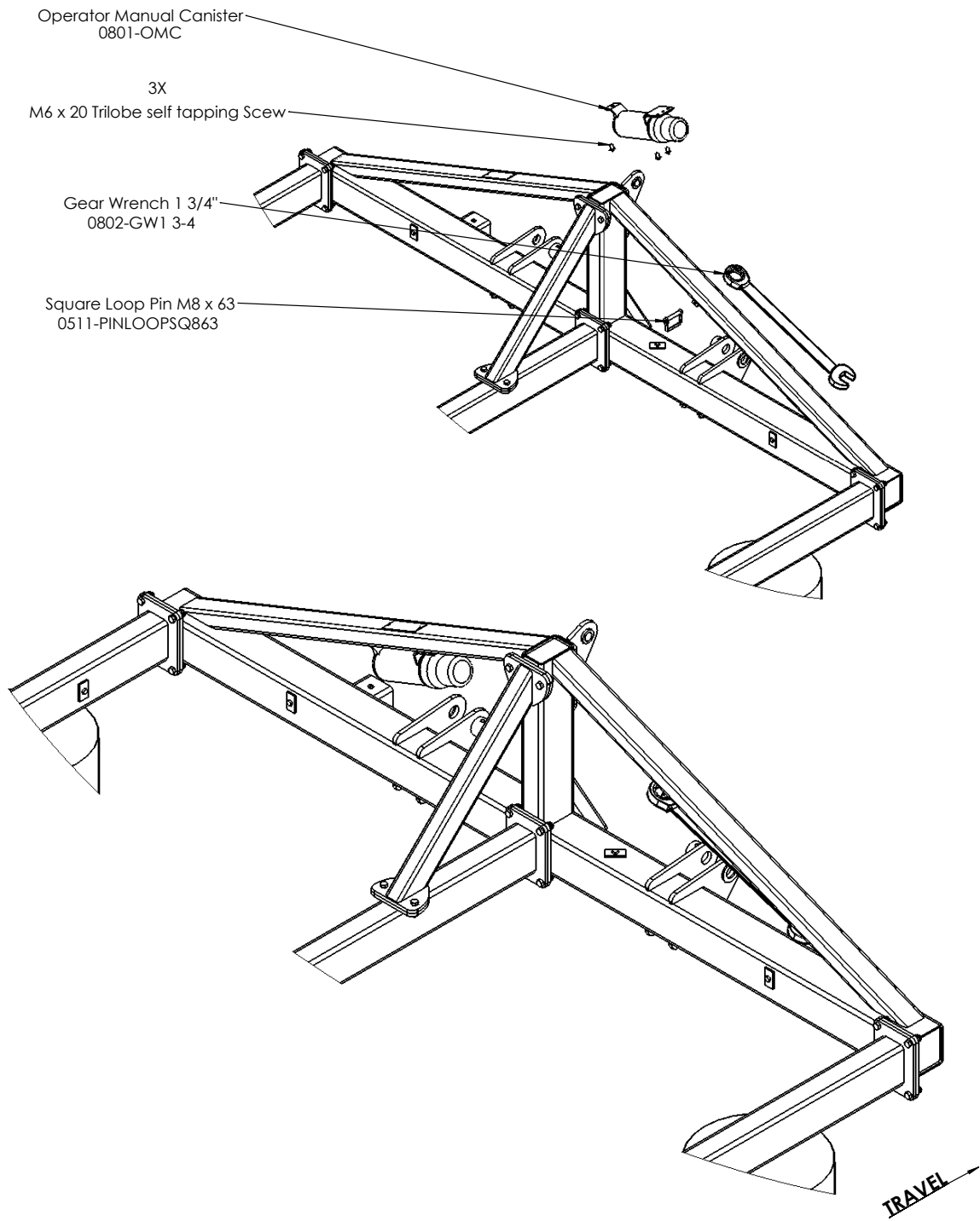

Step 6: Using the supplied self tapping bolts to attach the light brackets and the SMV sign and bracket. (on machined supplied with a light kit leave SMV bracket off until after light kit has been installed to allow cable to be drawn through centre rail).

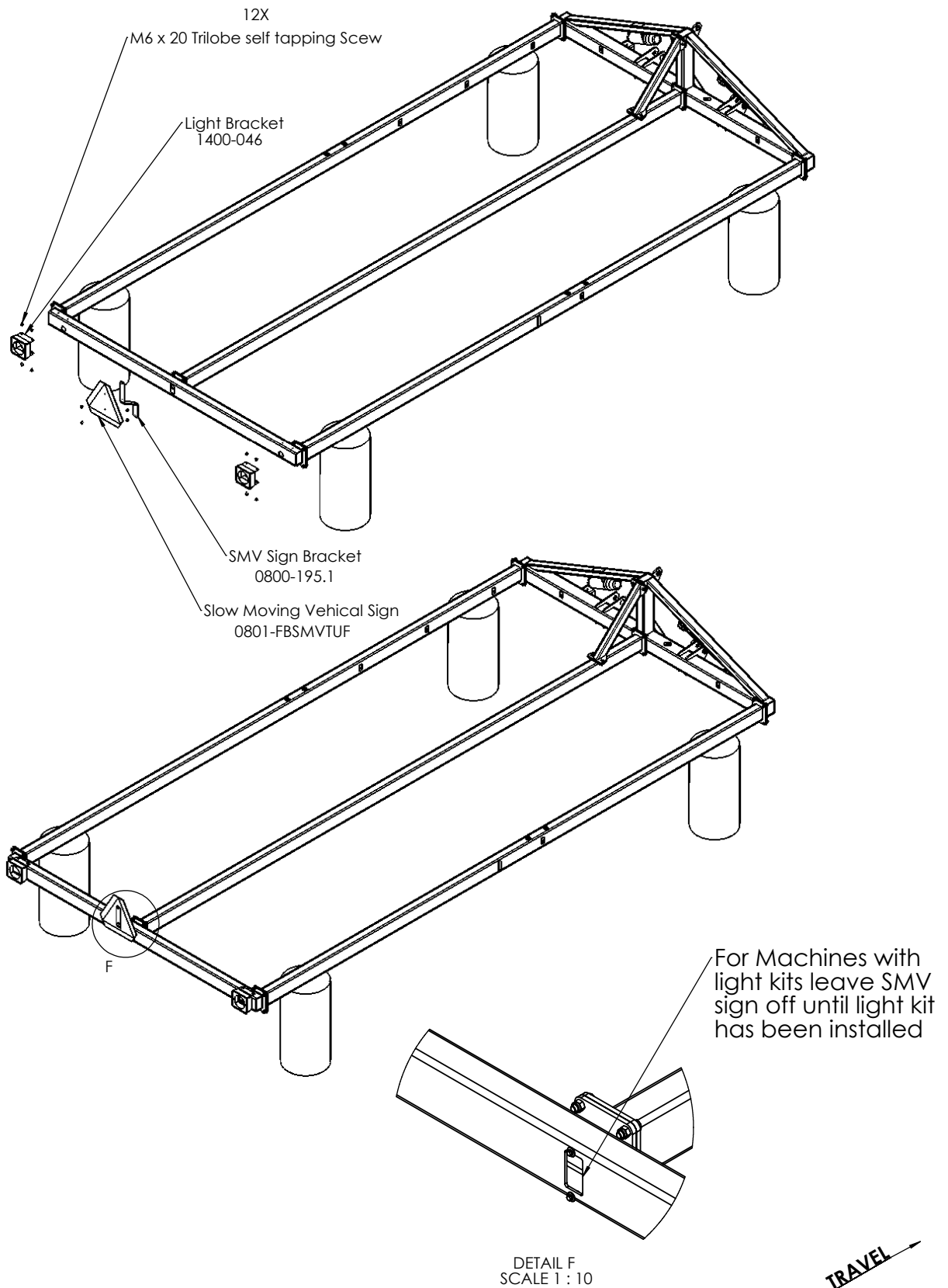

Step 7: Using appropriate lifting equipment lift the axle beam into position and install the pivot mounts using the bolts supplied.

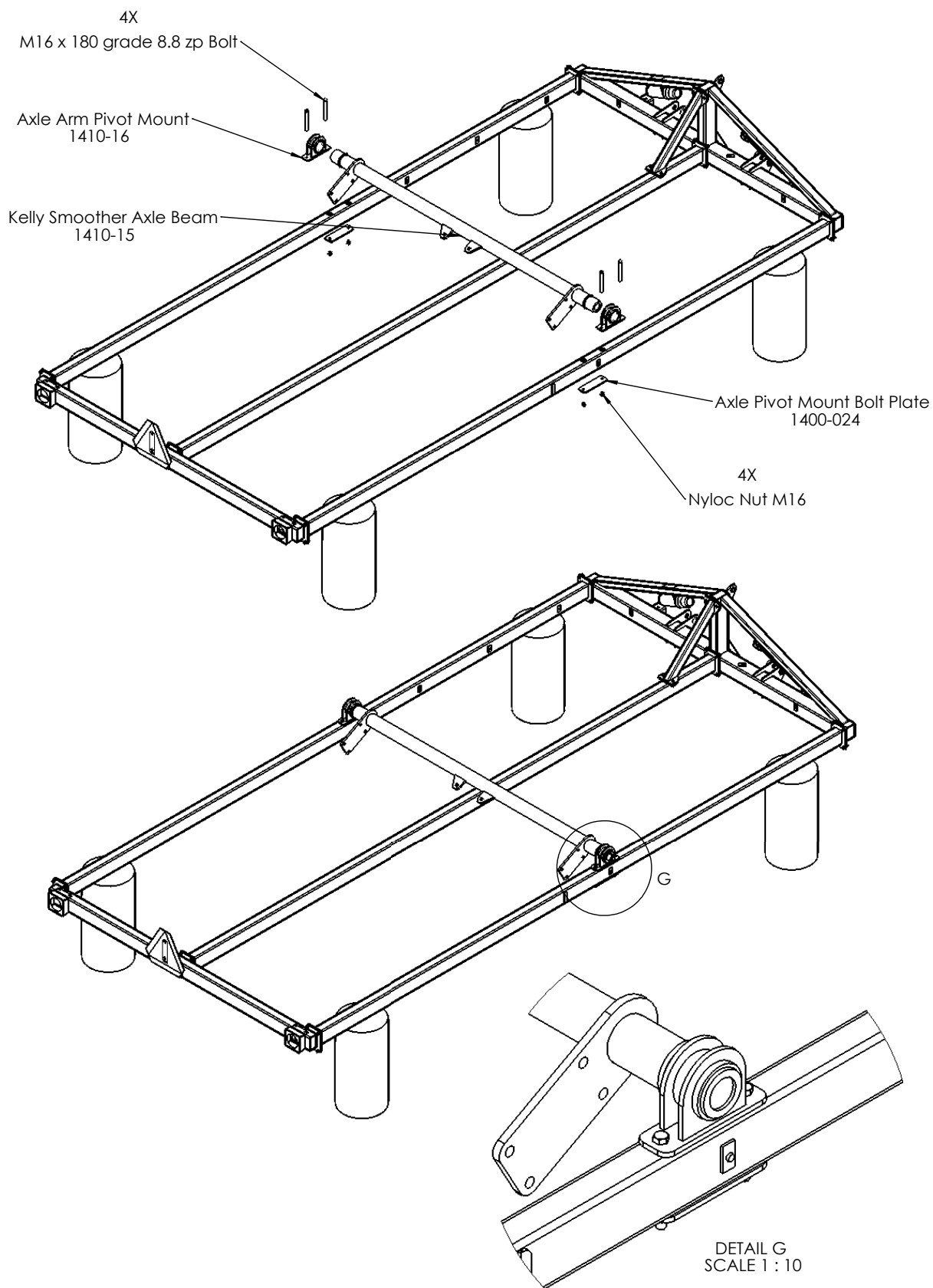

TRAVEL →

Please refer to technical bulletin 032 in the rear of the manual

Step 8: Using appropriate lifting equipment lift the axle arms into position and install the bolts supplied. (Ensuring hydraulic cylinder mounts are facing up and out as shown below).

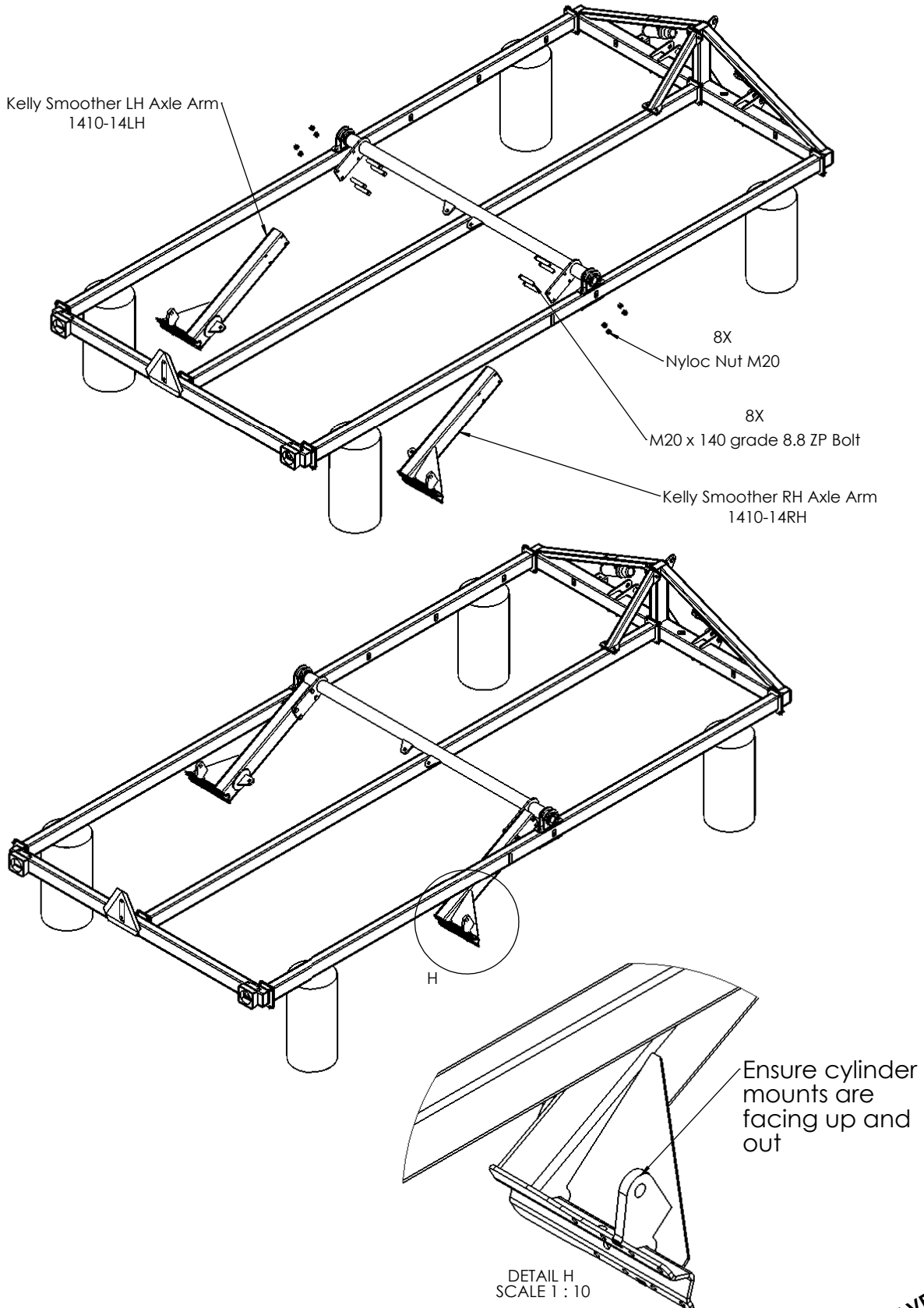

Please refer to technical bulletin 032 in the rear of the manual

Step 9: Position the axle brace arm in place and attach with the supplied bolts.

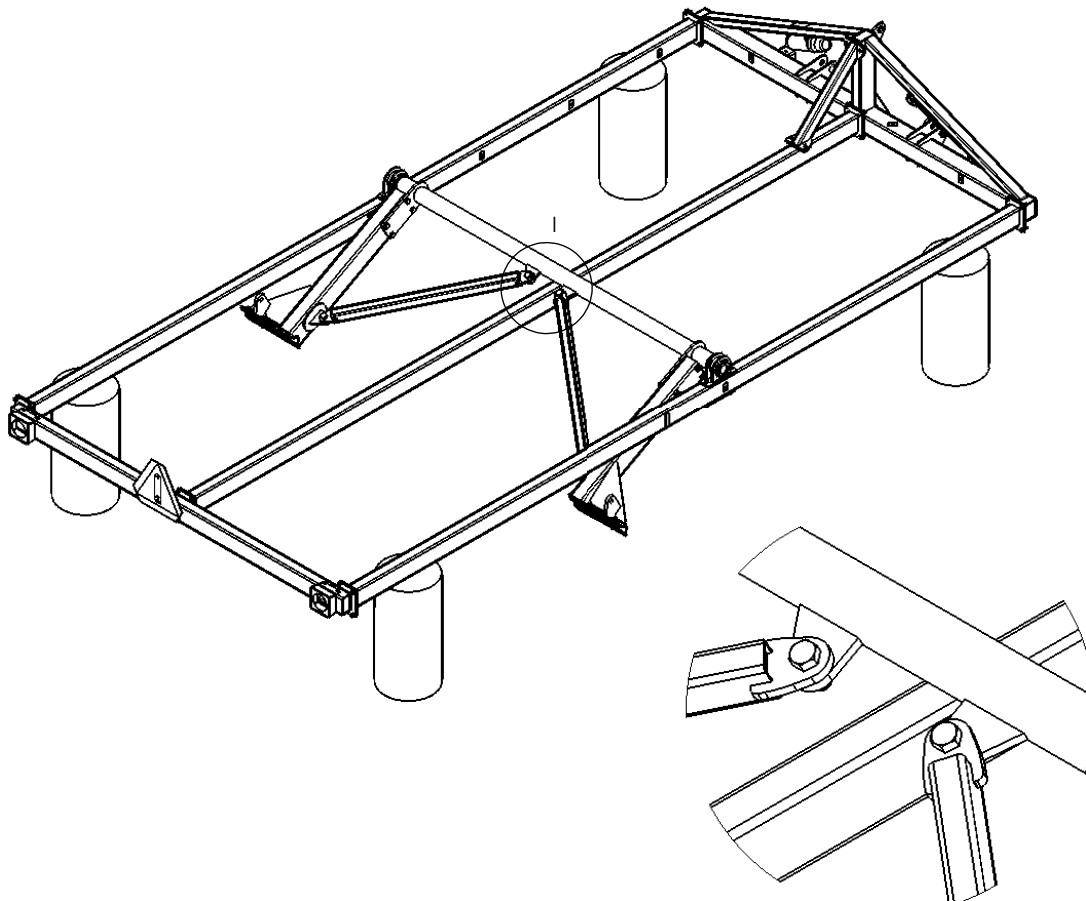
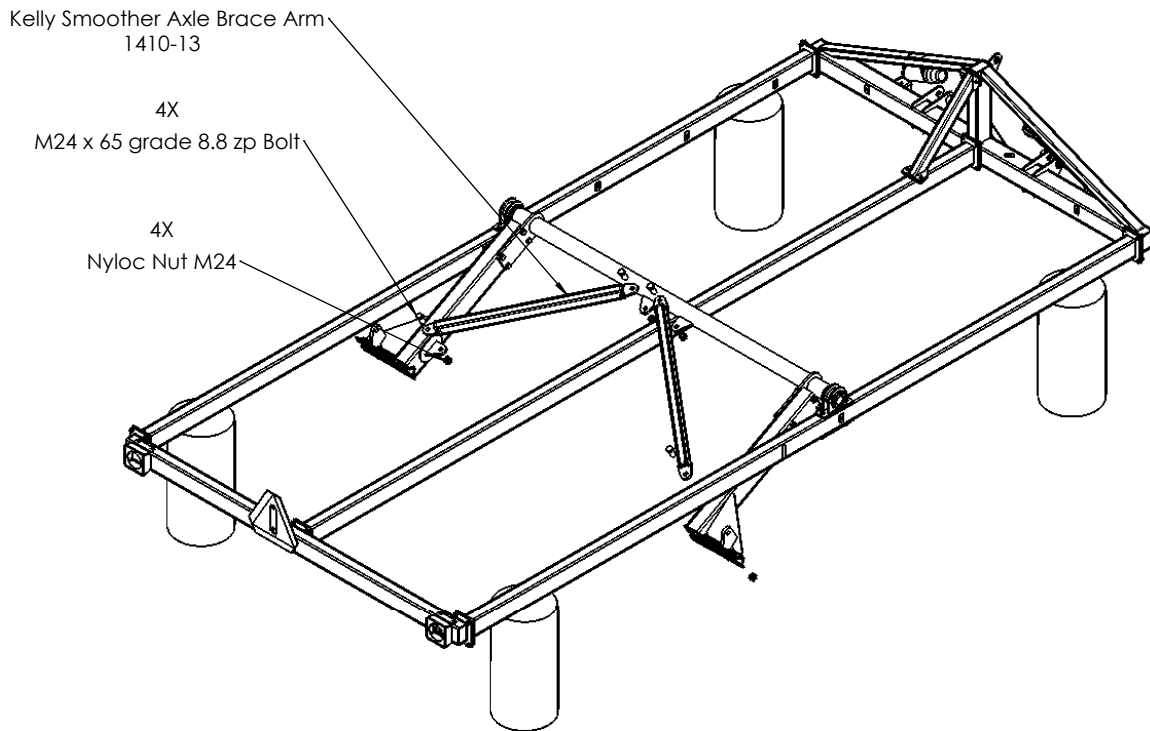

DETAIL I
SCALE 1 : 10

TRAVEL →

Please refer to technical bulletin 032 in the rear of the manual

Step 10: Position the hydraulic lift mounts in place and attach with the supplied U-bolts. (Ensure tab on back of mounts is positioned hard up against under side of rail and mounts are pushed up against locating blocks).

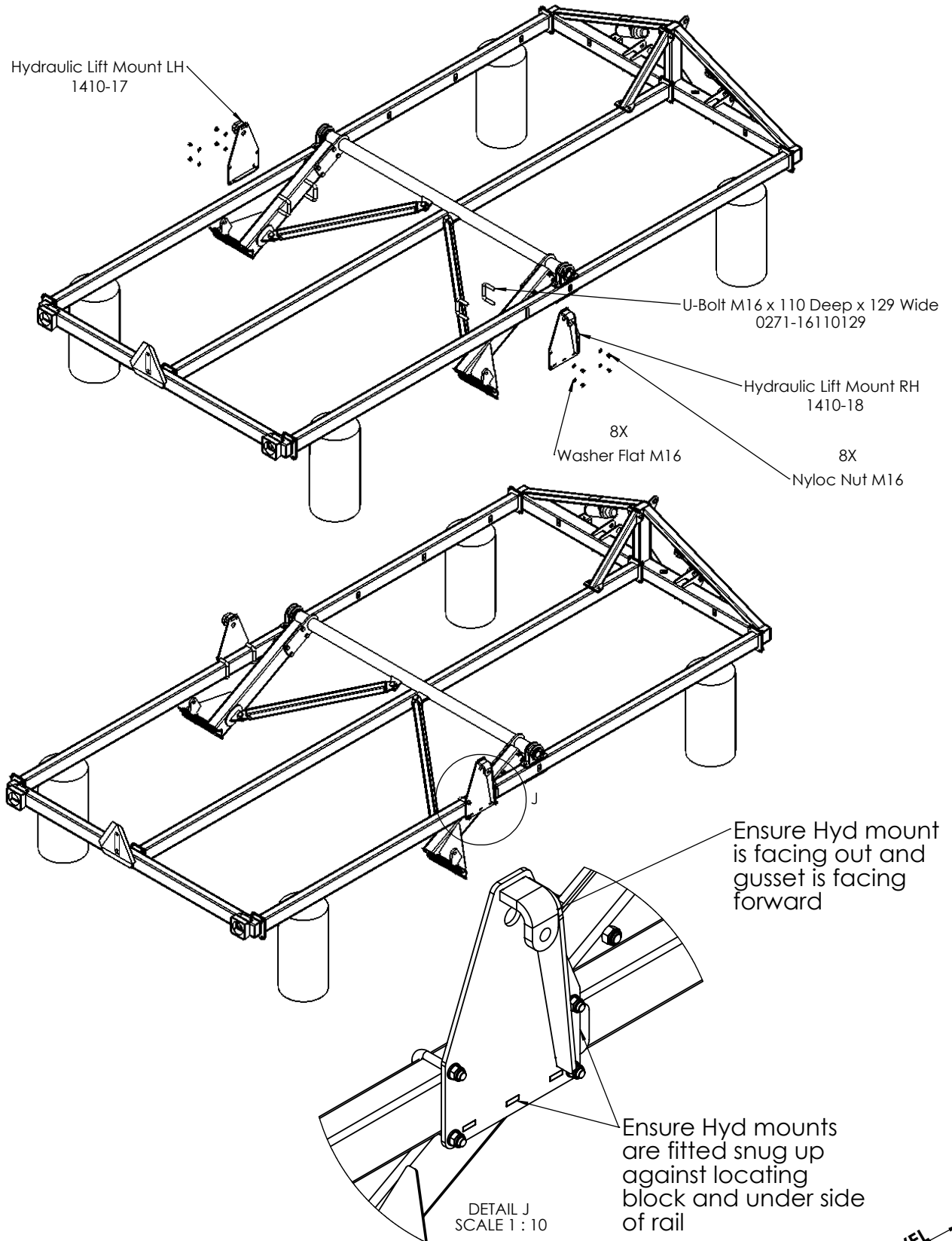

Please refer to technical bulletin 032 in the rear of the manual

Step 11: Install the 2.5" Bore x 16" Stroke Hydraulic Cylinders using the pins and clips supplied. Install with ports facing up and rod end facing down.

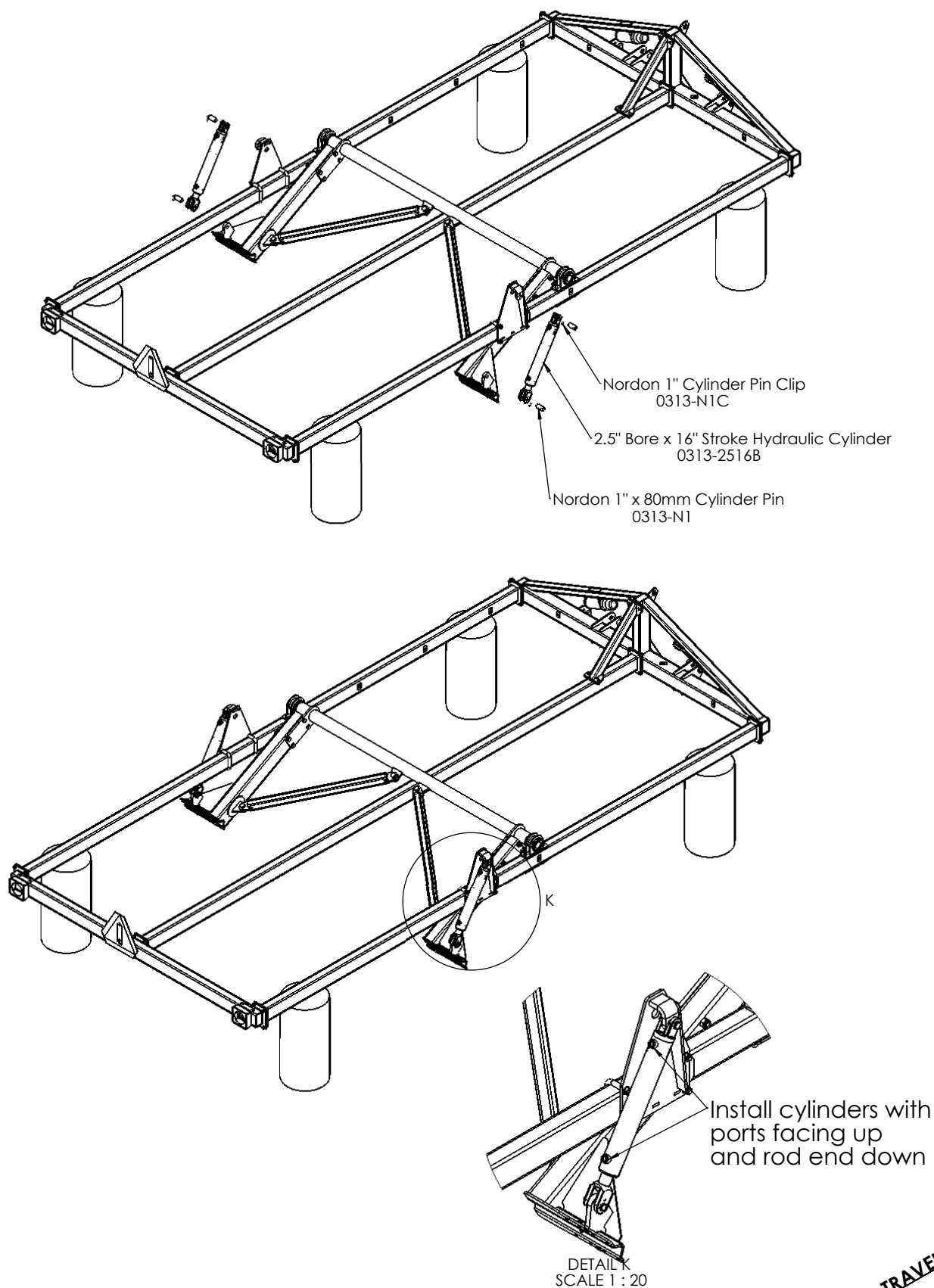

Please refer to technical bulletin 032 in the rear of the manual

Step 12: Install the axles and wheels using the axle clamp plates and bolts provided. Fit all bolts loosely before finally tightening.

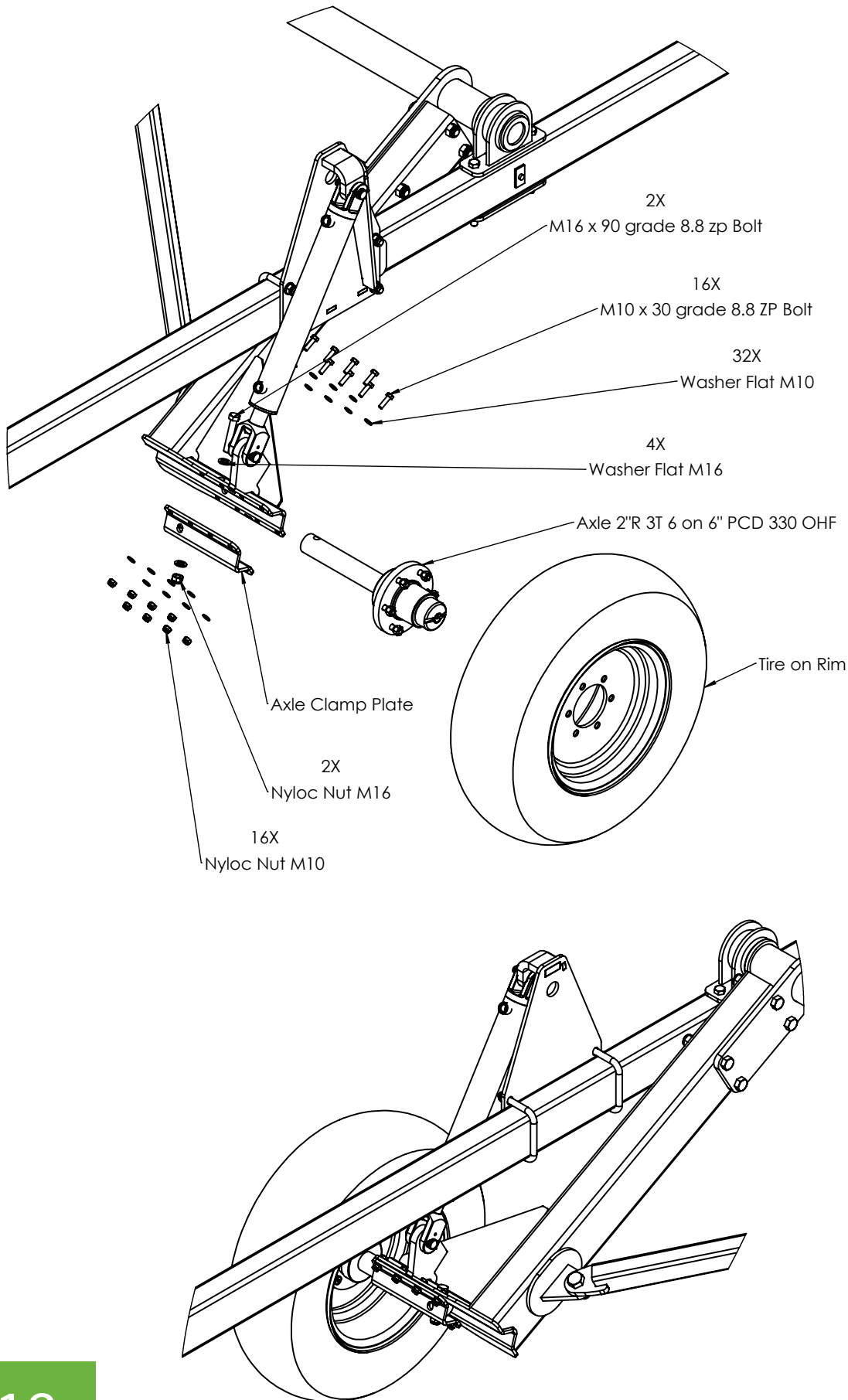

Step 13: Using appropriate lifting equipment lift the Drawbar into position and install using the pins, bolts and cotter pin supplied. (Ensuring hydraulic cylinder mount is facing up as shown below).

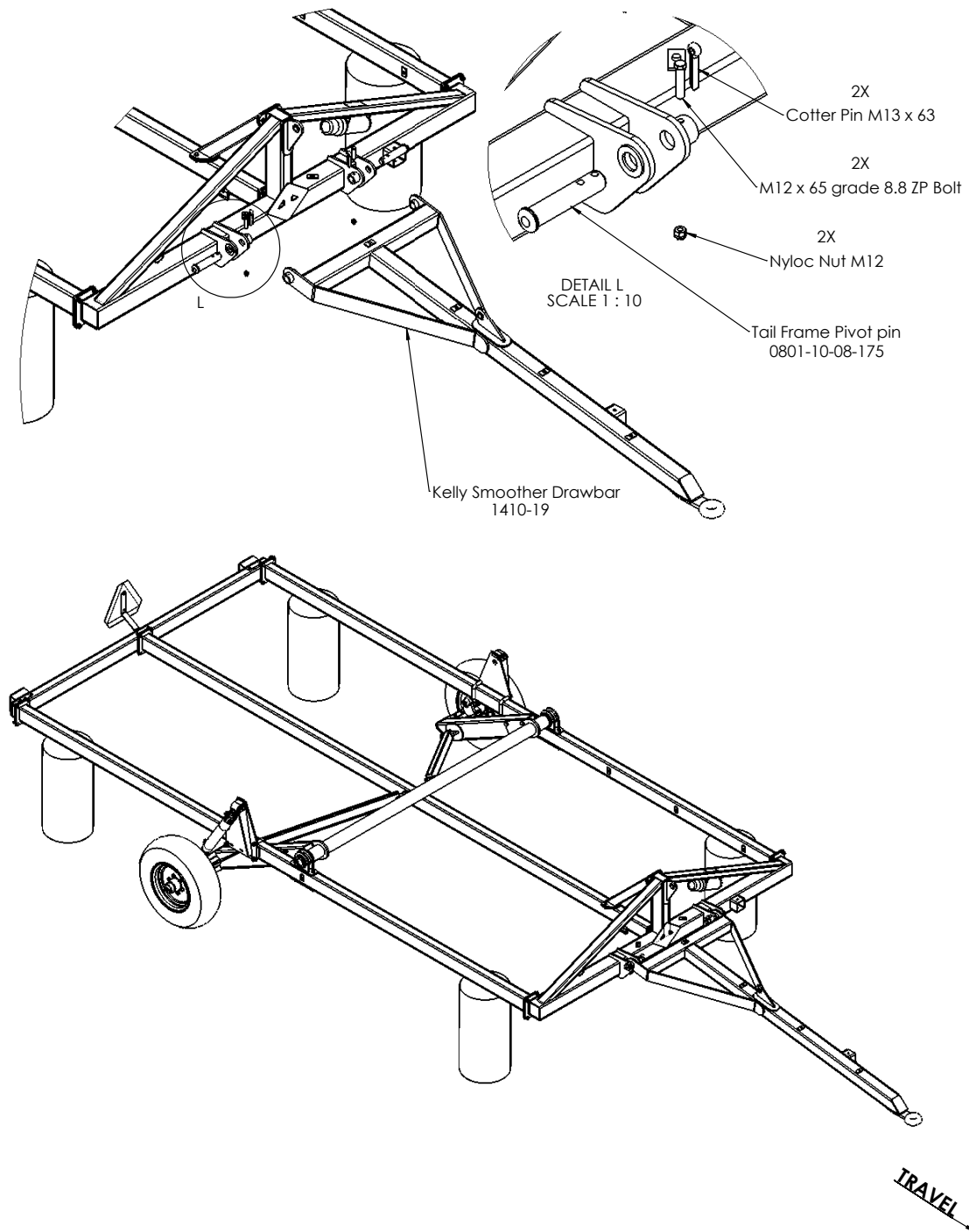

Step 14: Install the 2.5" Bore x 6" Stroke Extended Cylinder using the pins and clips supplied. Install with ports facing up and rod end facing up.

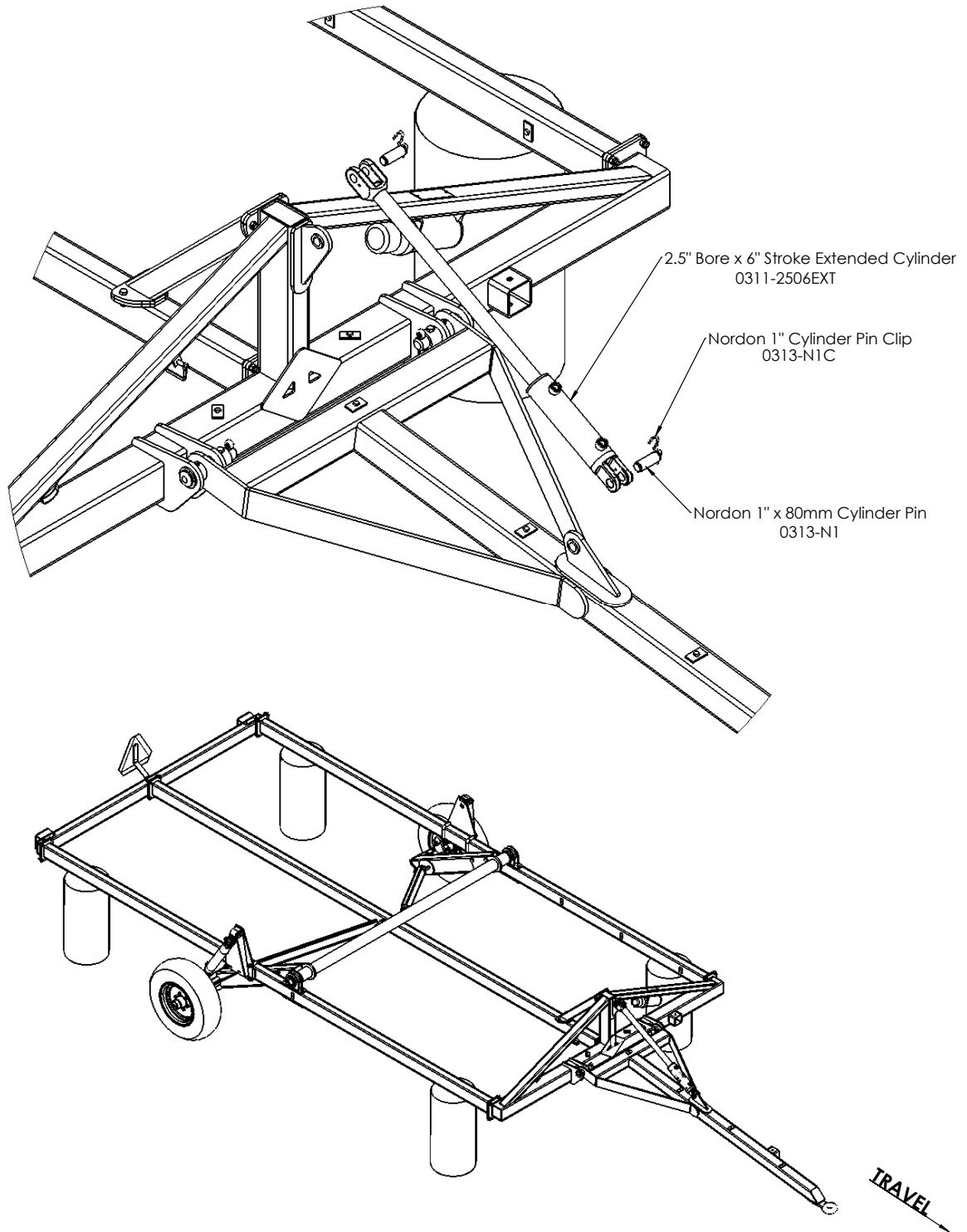

Step 15: Install the jack mount on the jack using the U-bolts provided. Install jack and mount into the receiver with the jack pin. Attach the safety chain using the supplied chain connector.

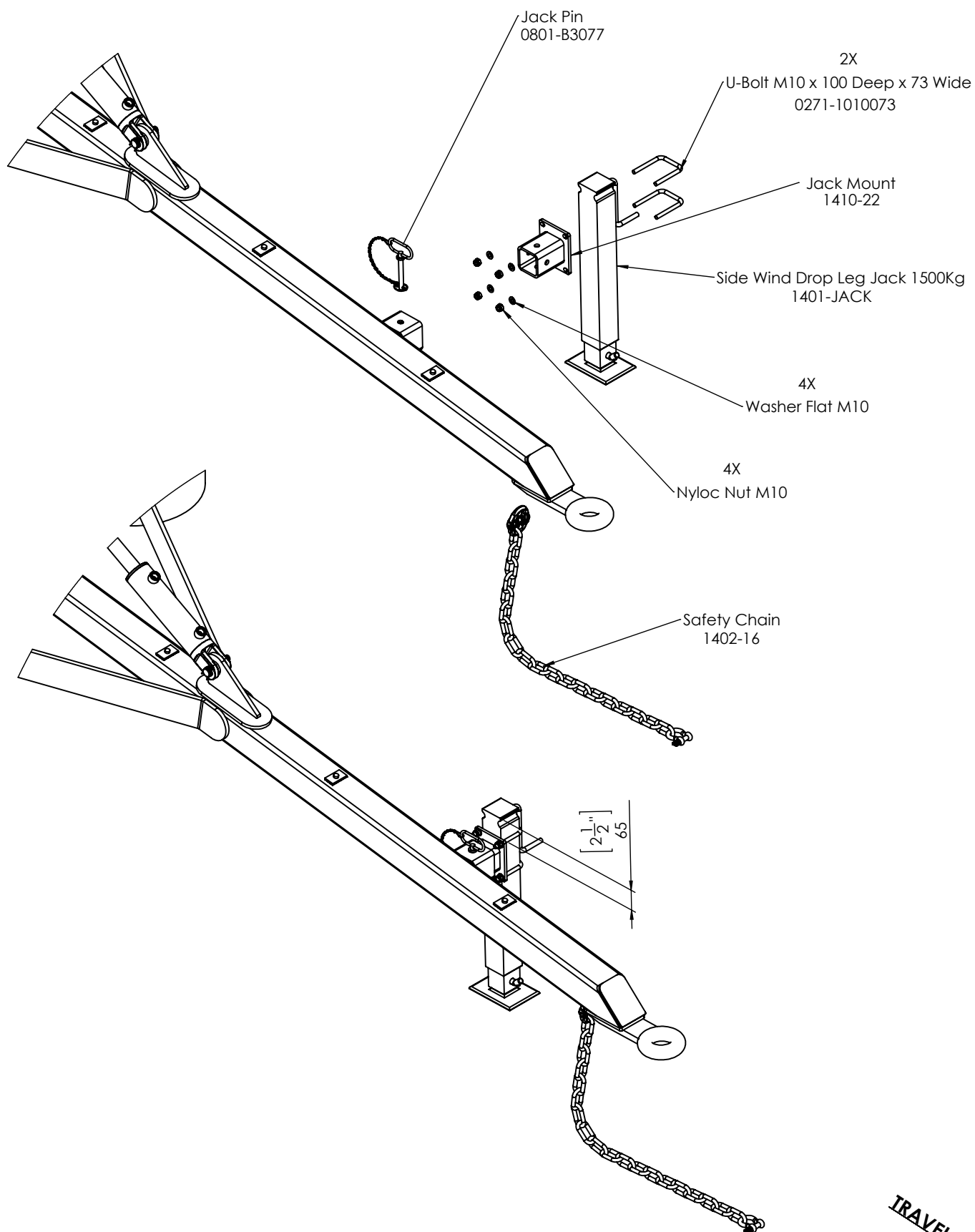

TRAVEL

Step 16: Using appropriate lifting equipment lift the machine and remove the stands.

Alternatively if suitable lifting equipment is not available the machine hydraulics can be connected as per page _____ and the machine can be raised using the hydraulics to remove the stands.

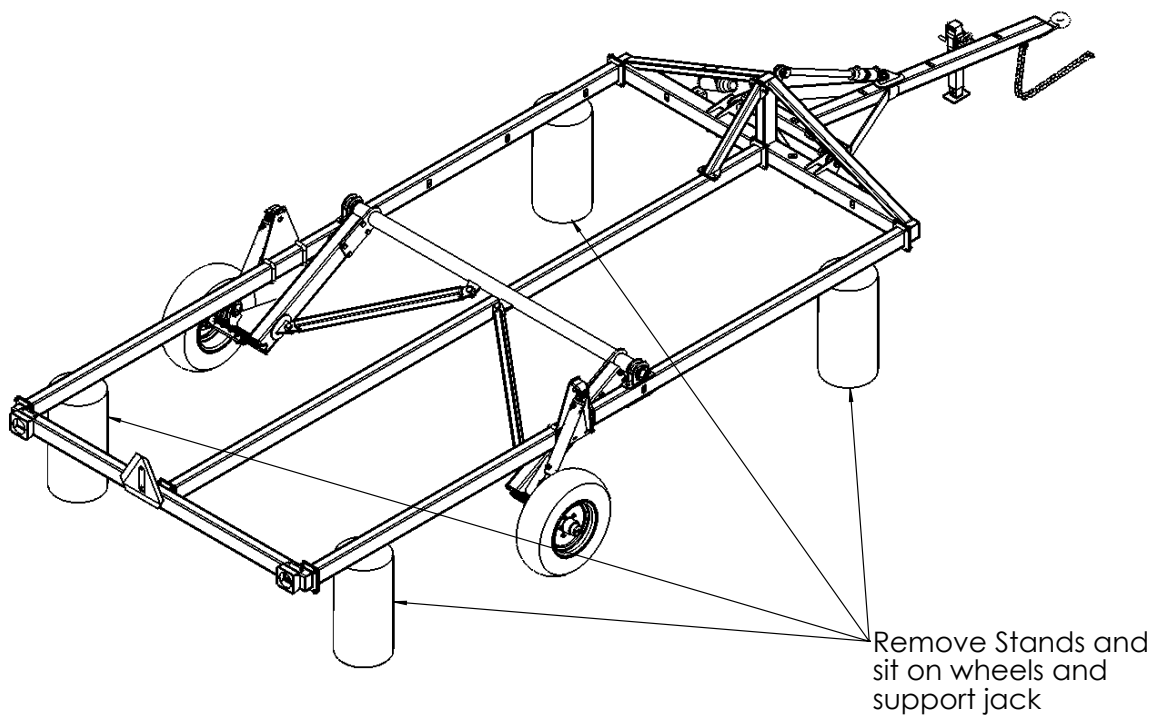

TRAVEL →

Step 17: Using appropriate lifting equipment lift the short front module into position and attach with the U-Bolts supplied.

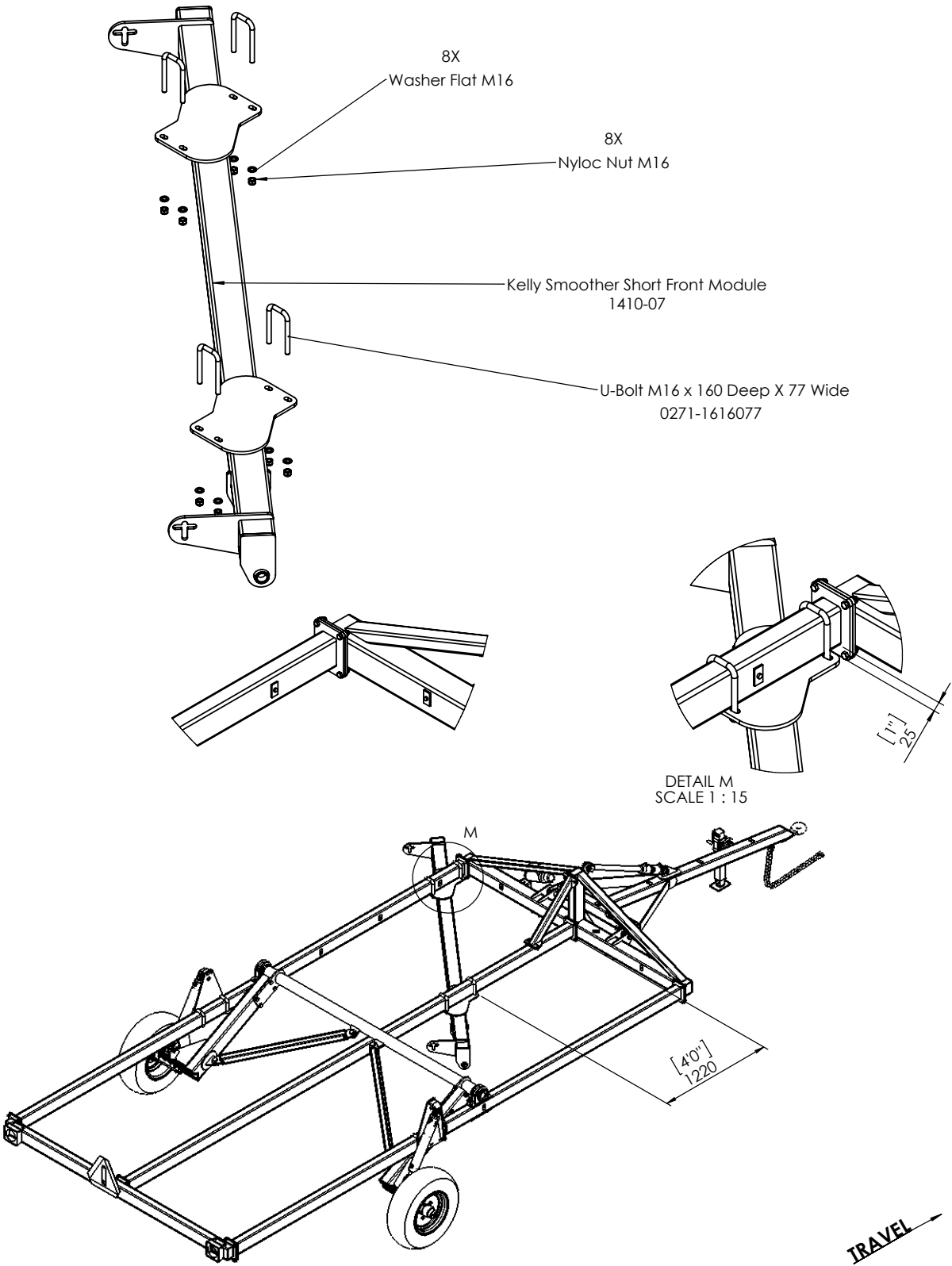

Step 18: Using appropriate lifting equipment lift the long module beam into position and attach with the U-Bolts supplied.

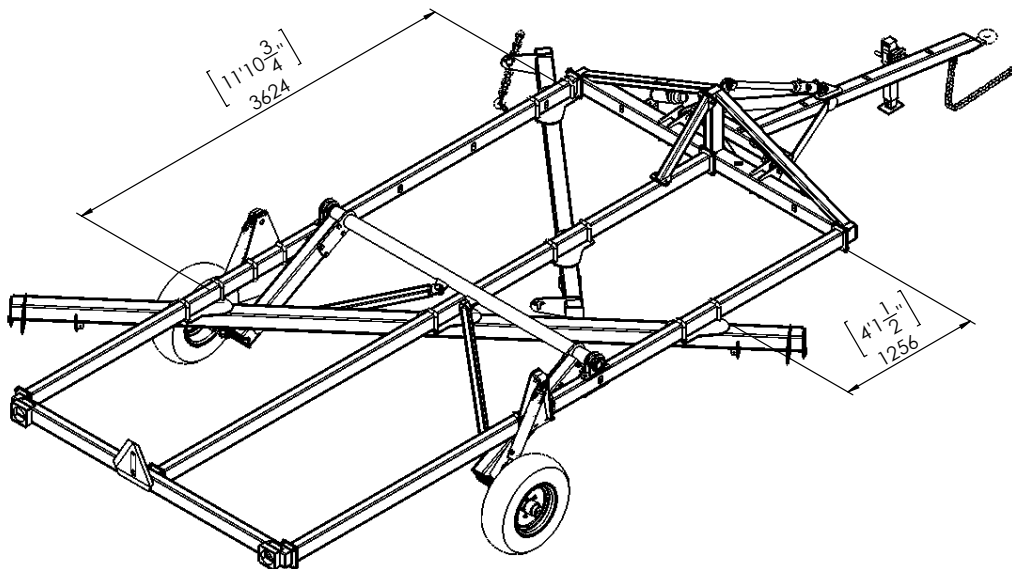
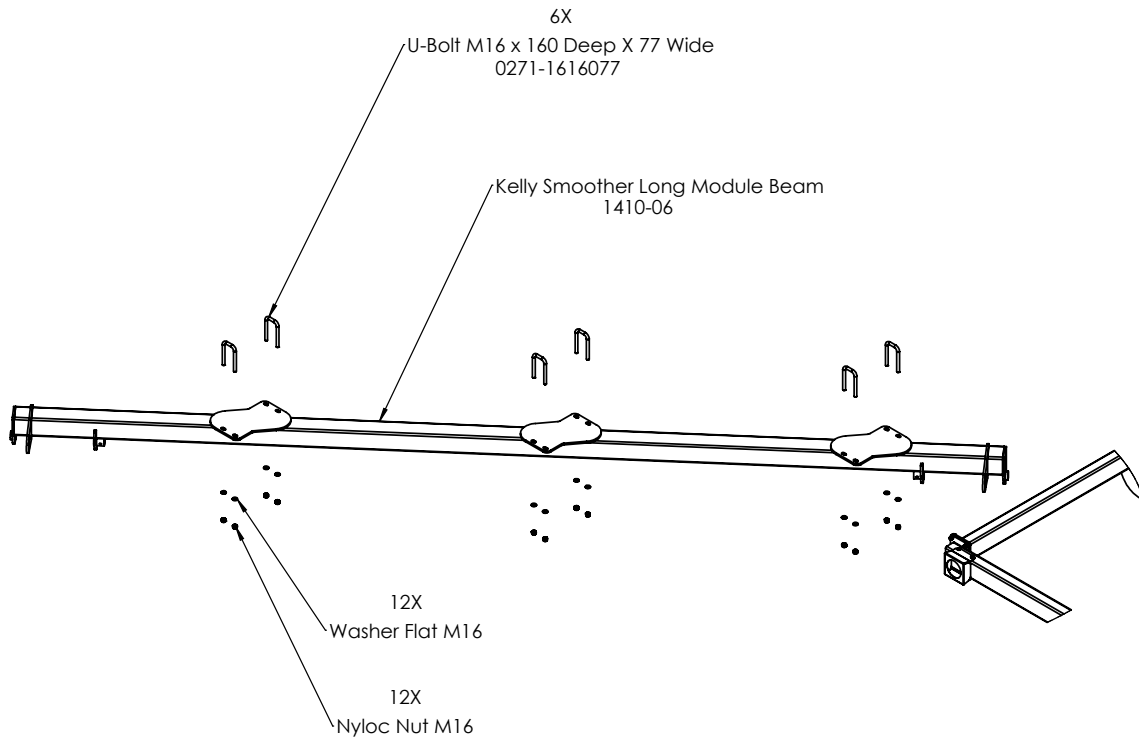

Step 19: Using appropriate lifting equipment lift the short rear module into position and attach with the U-Bolts supplied.

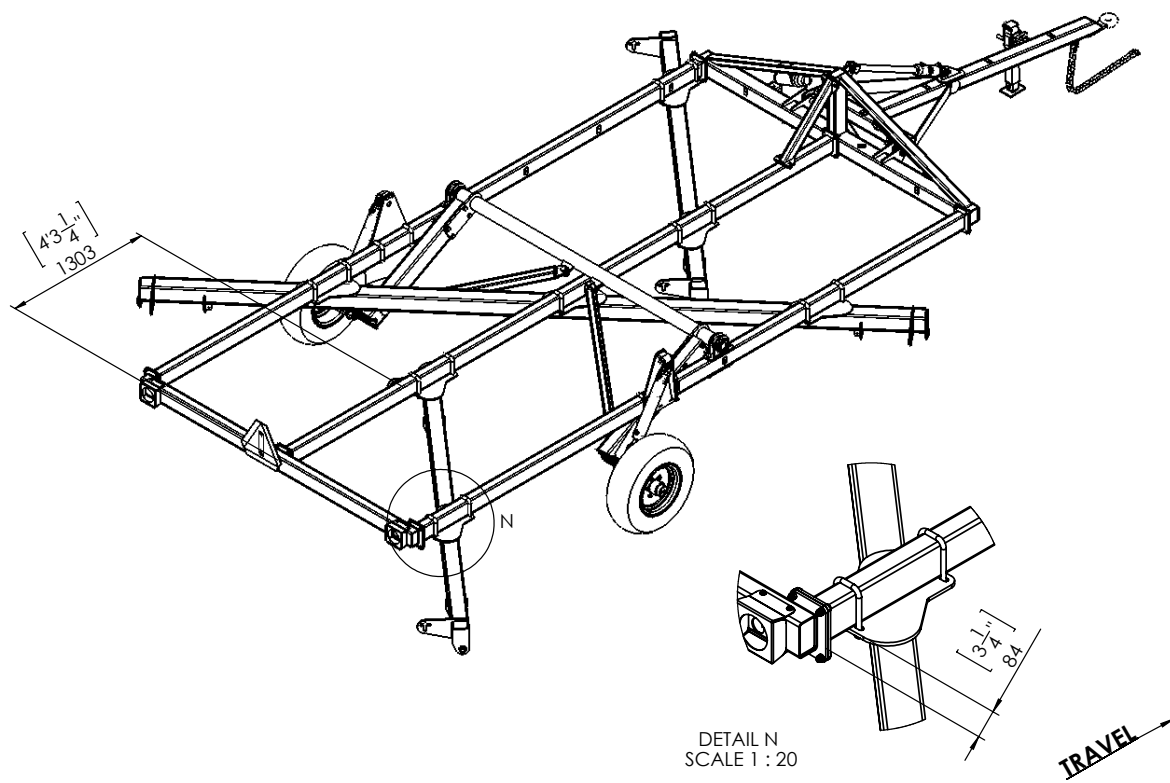
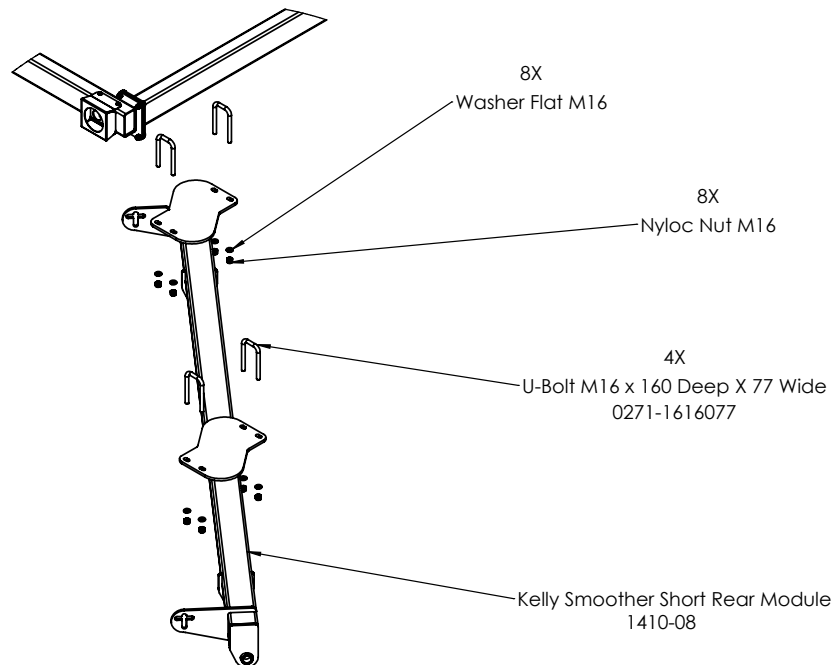

Step 20: Install the front chain mount plate and adjusting chain using the pin and bolts supplied.

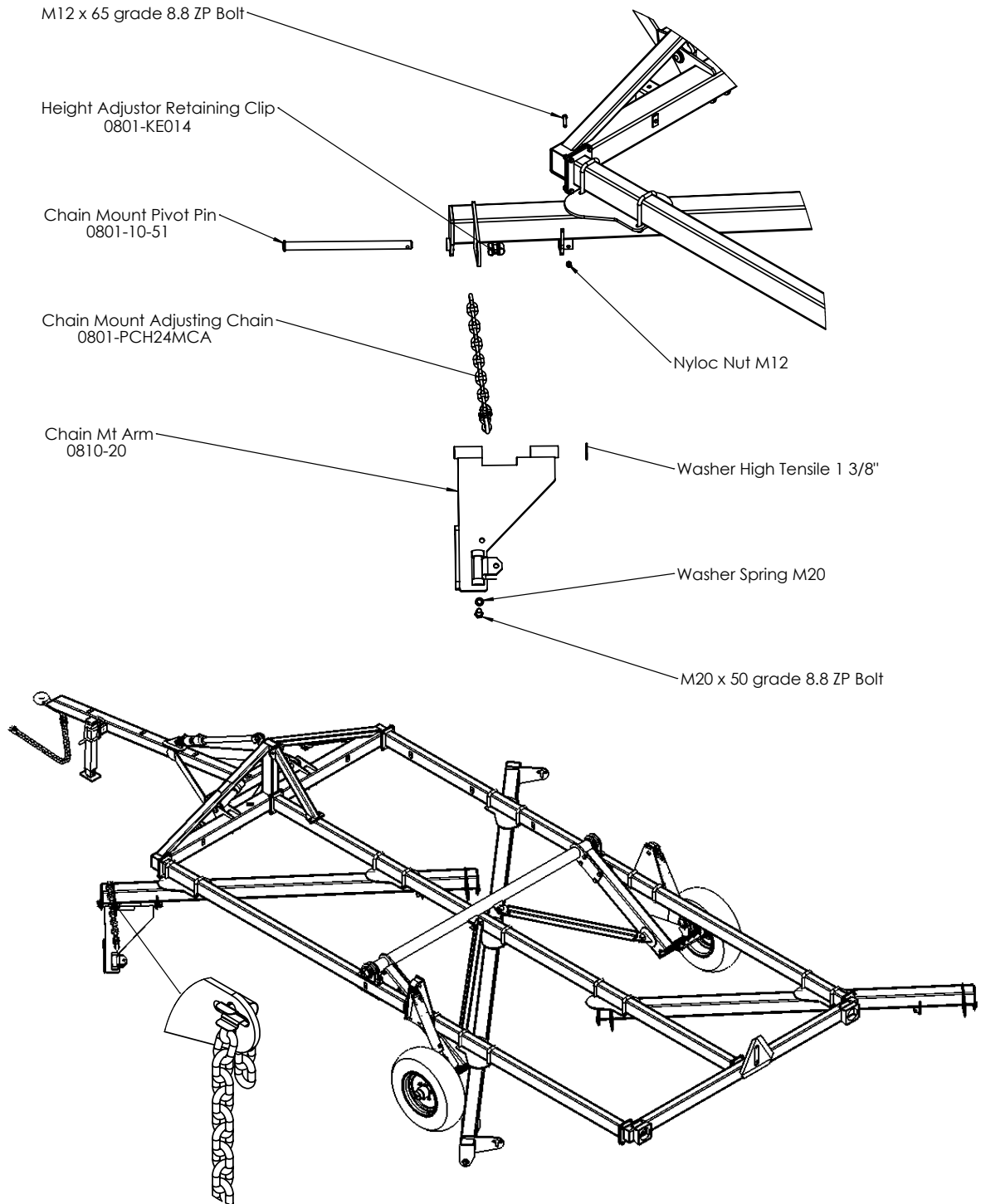

Fit adjusting chain through key hole in plate, using the supplied retaining clip to hold in place

TRAVEL

Step 21: Assemble the 3 chain tension assemblies shown below, 2 required with the "rear" body (for the short front and short rear modules) and one required with the "front" body (for the long middle module).

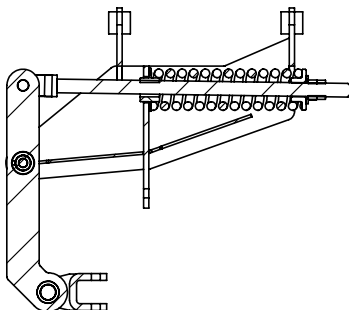
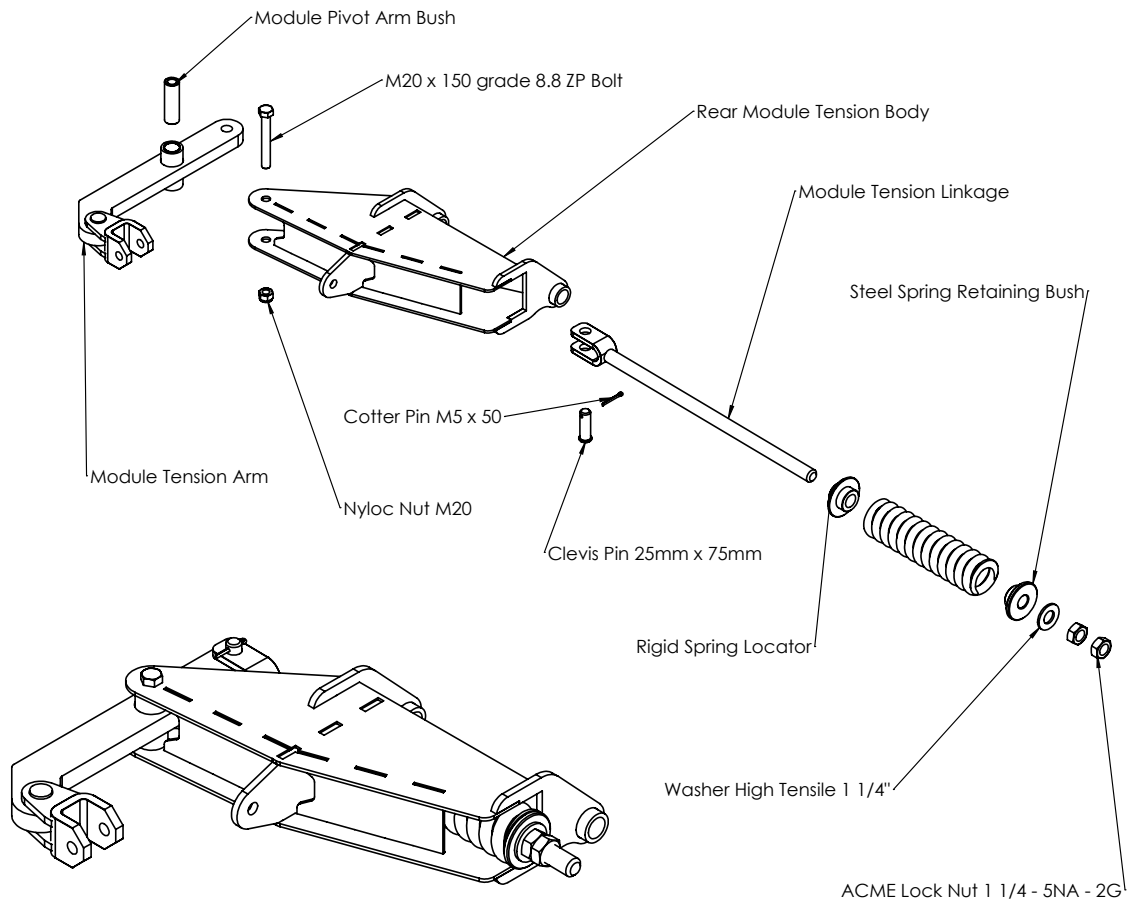

Rear module tension assembly used on both short modules

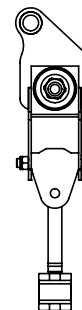
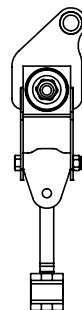

Front module tension assembly used on long module

Step 22: Install one of the rear module tension assemblies from step 21 and the adjusting chain using the pin and bolts provided.

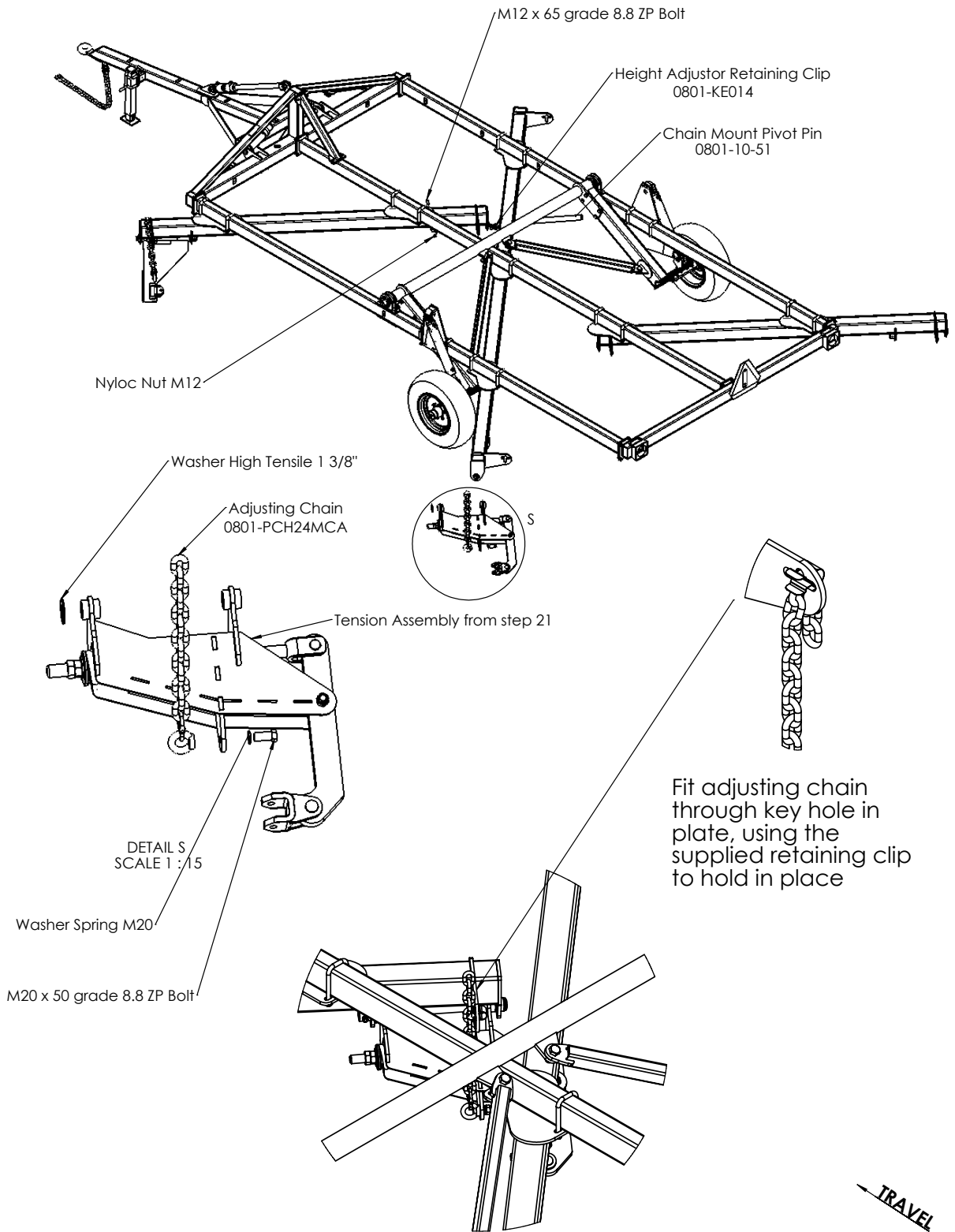

Step 23: Install the Middle chain mount plate and adjusting chain using the pin and bolts supplied.

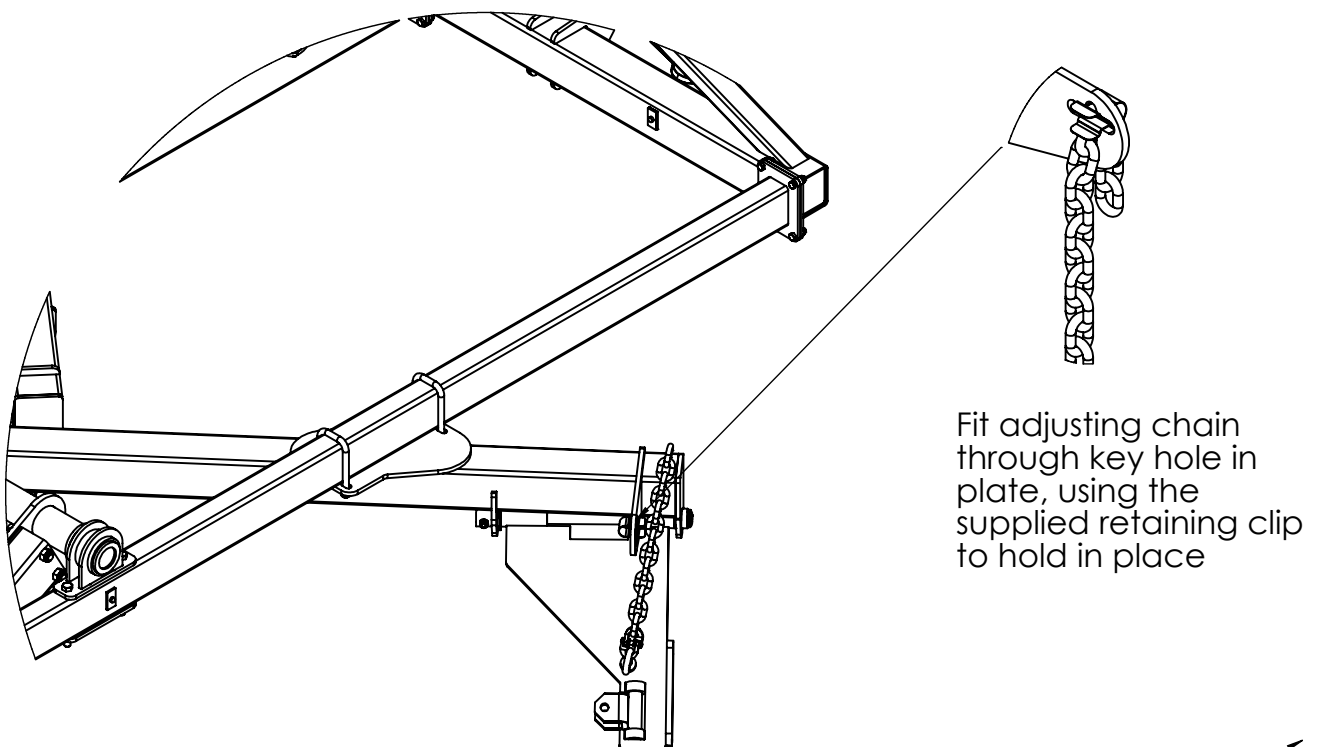
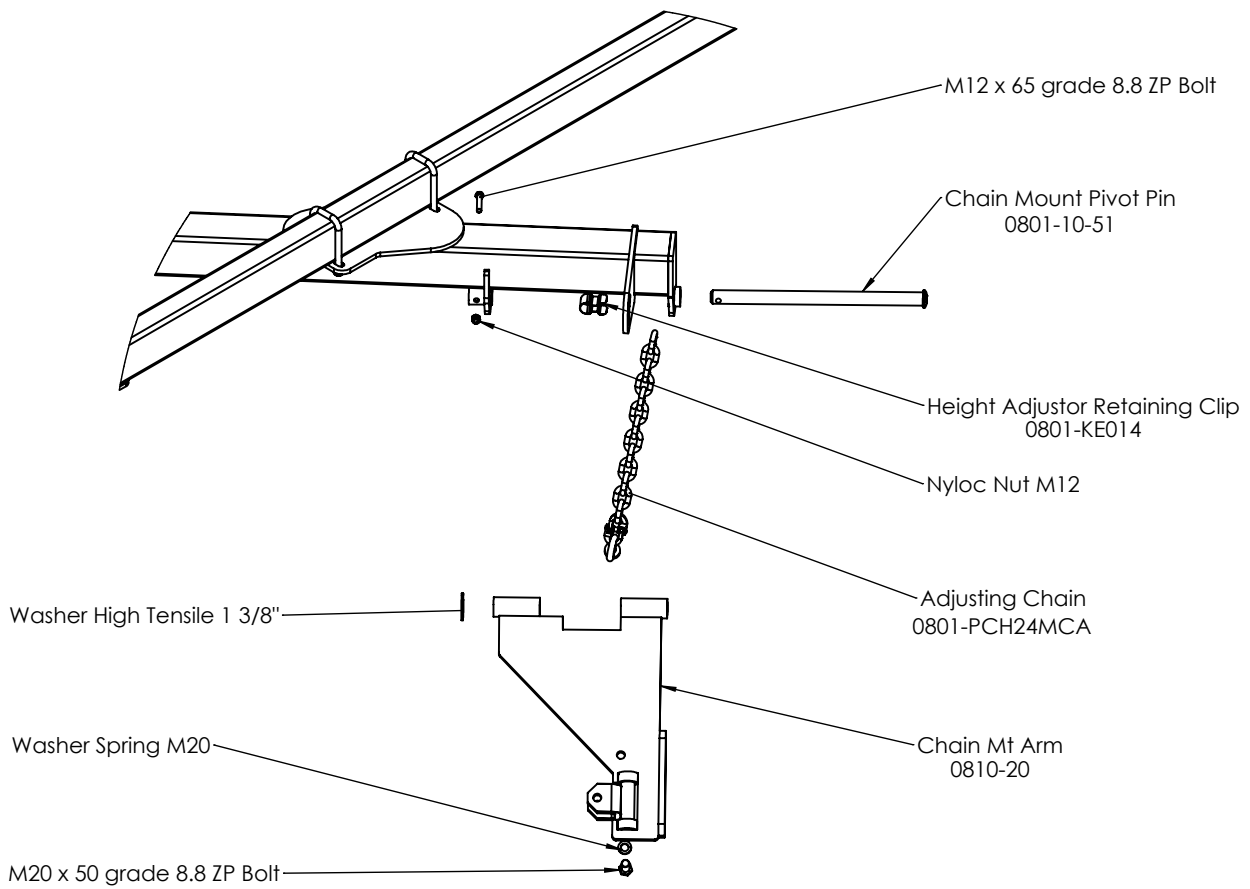

TRAVEL →

Step 24: Install the front chain tension assembly from the step 21 and the adjusting chain using the pin and bolts provided.

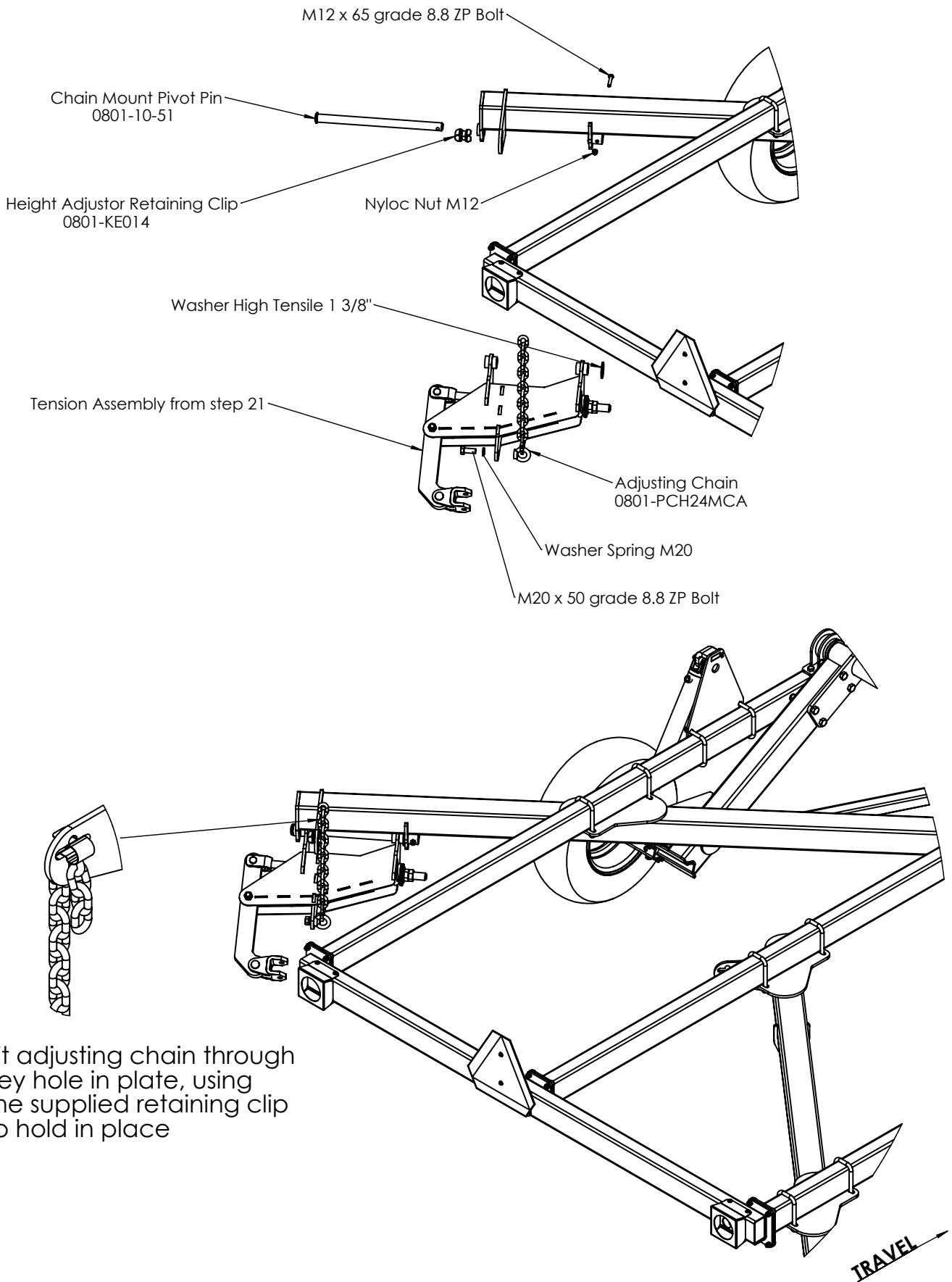

Step 25: Install the rear chain mount plate and adjusting chain using the pin and bolts supplied.

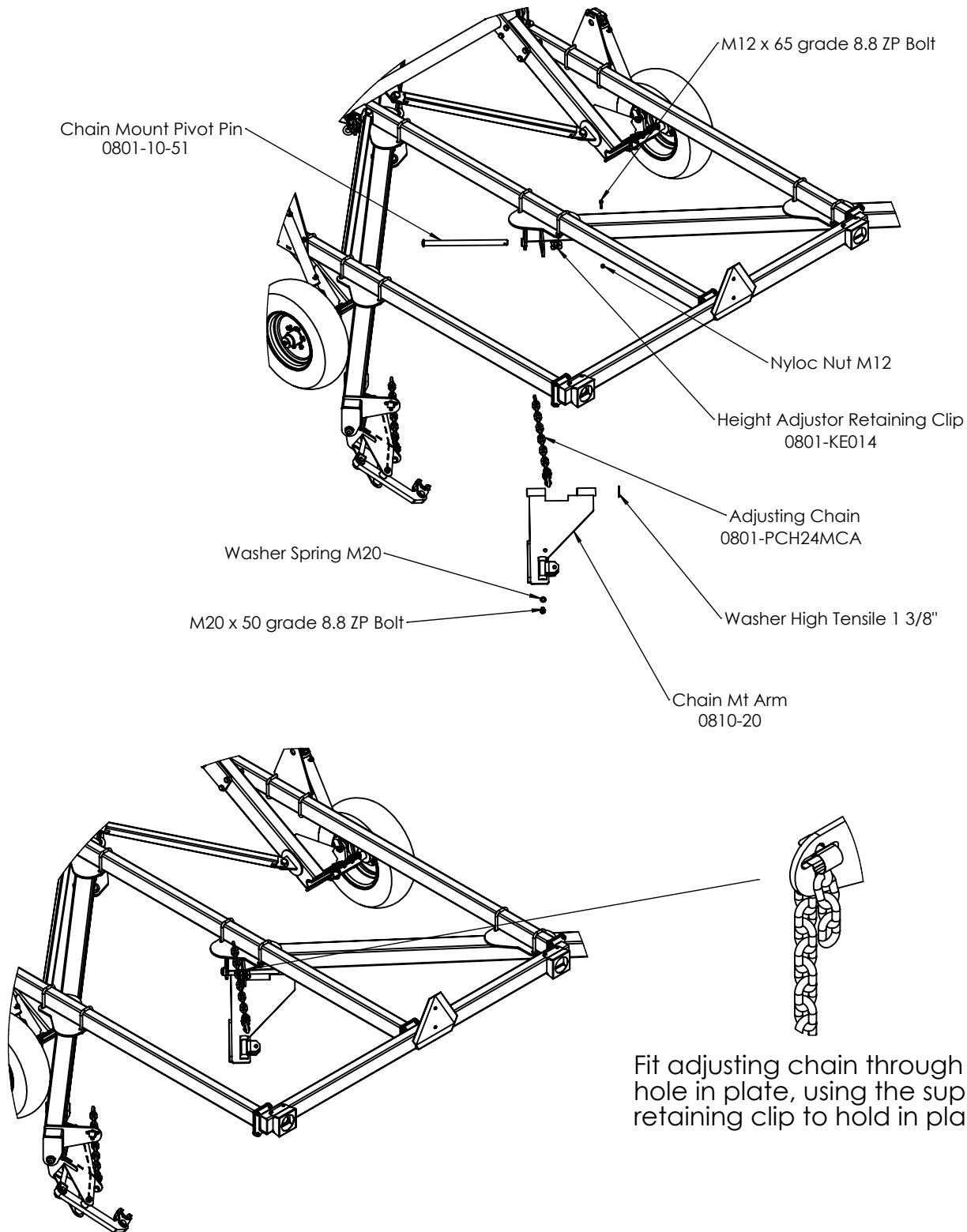

TRAVEL

Step 26: Install the rear chain tension assembly from step 21 and the adjusting chain using the pin and bolts provided.

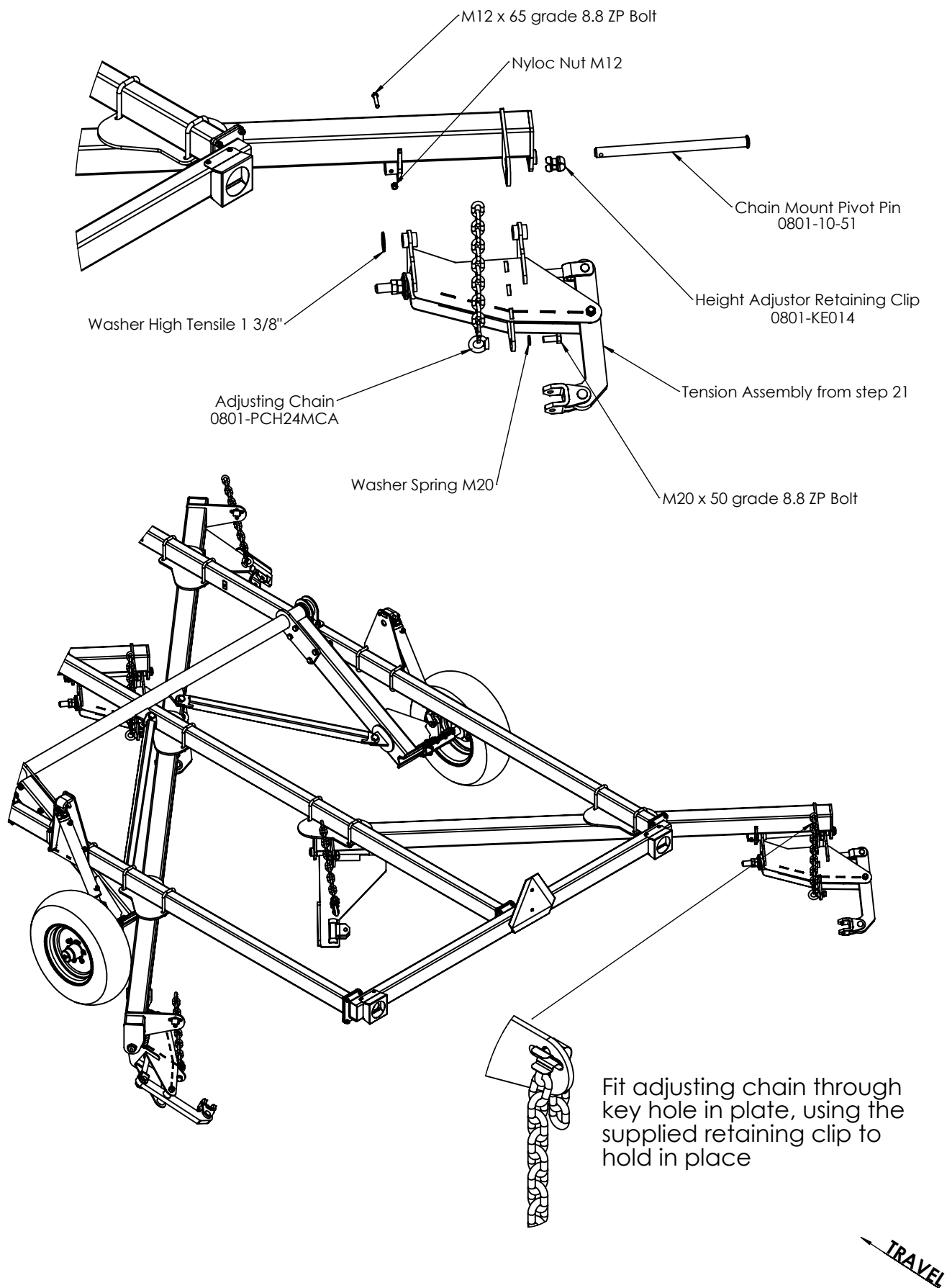

Step 27: Install tie plate discs and swive unit using the bolts supplied. Fit swivel units with the fixed end facing forward to prevent dirt getting forced into the seal of the swivel. Fit the disc chain tie plate discs with the concave face facing forward.

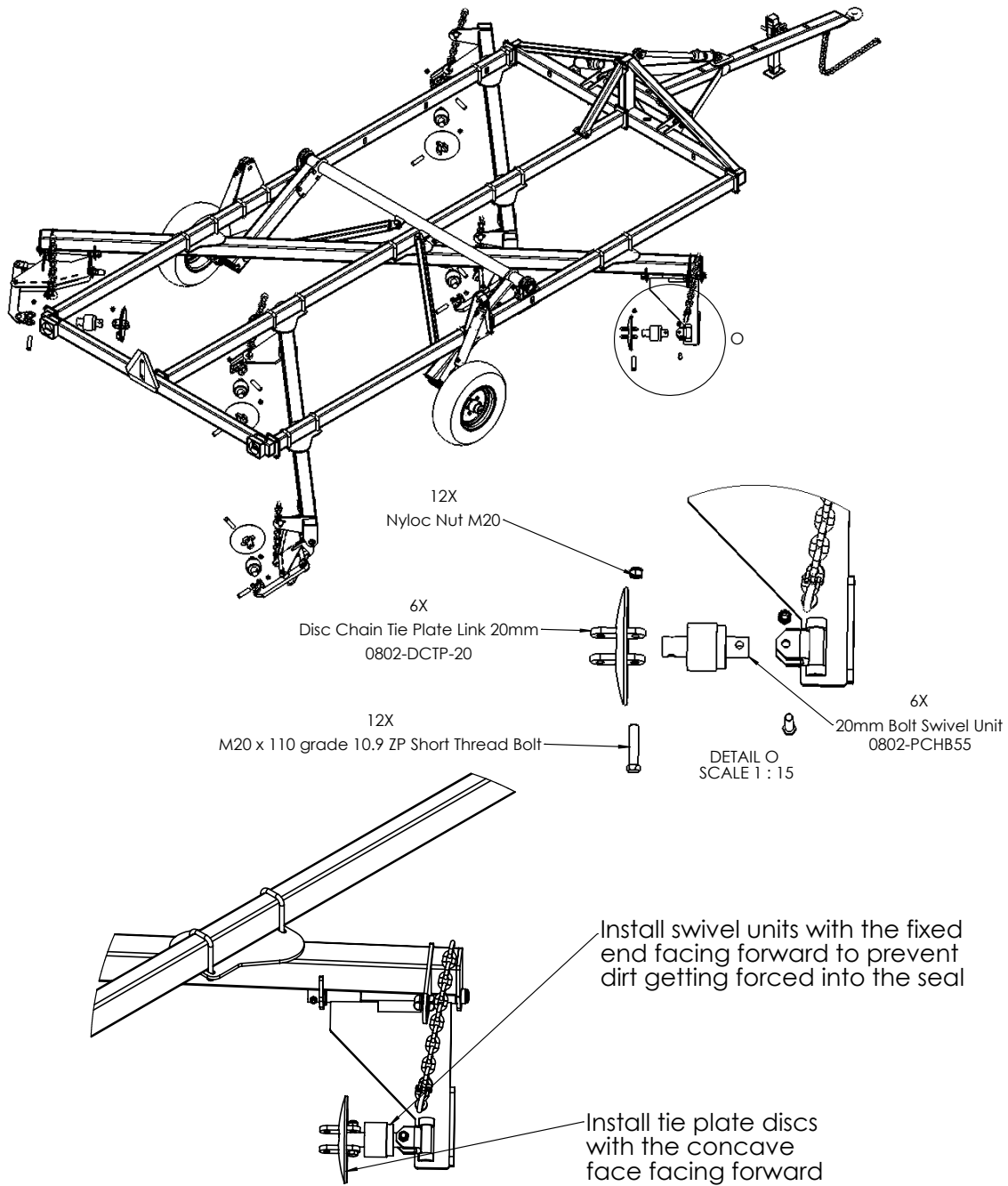

Step 28: Install disc chain lengths with the concave face facing forward

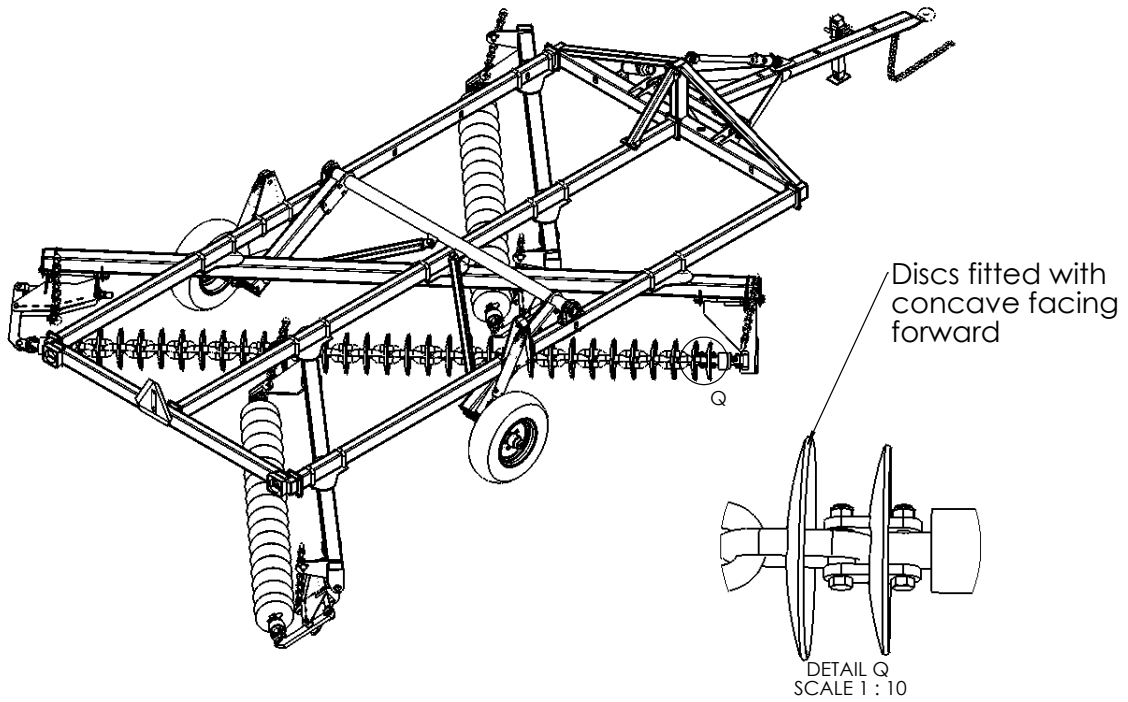
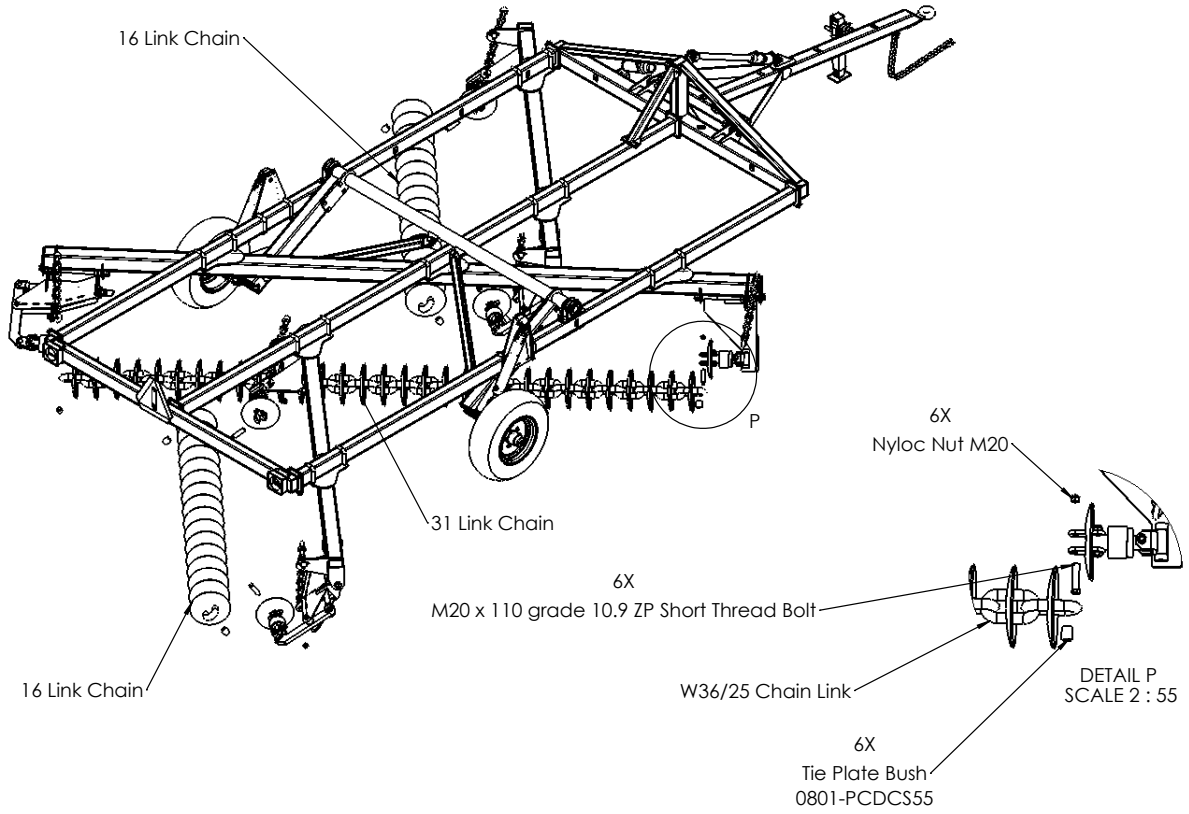

TRAVEL →

Section 3

Hydraulic Setup



Part Number
1402-HK

Description
Kelly Smoother Hydraulic Kit

For Machines Built:
01/07/2014 (KS-115004) -

Revision
A-0

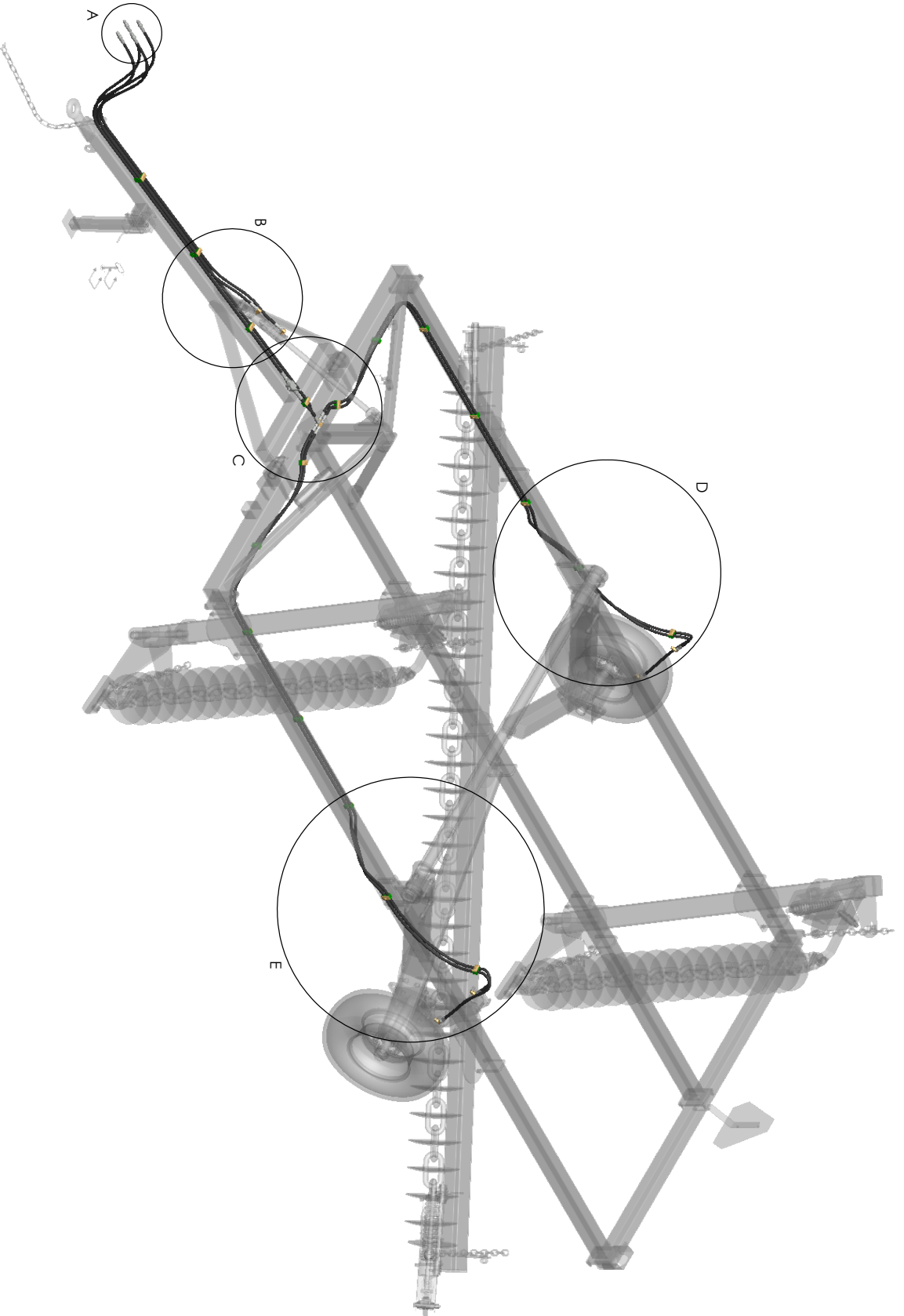

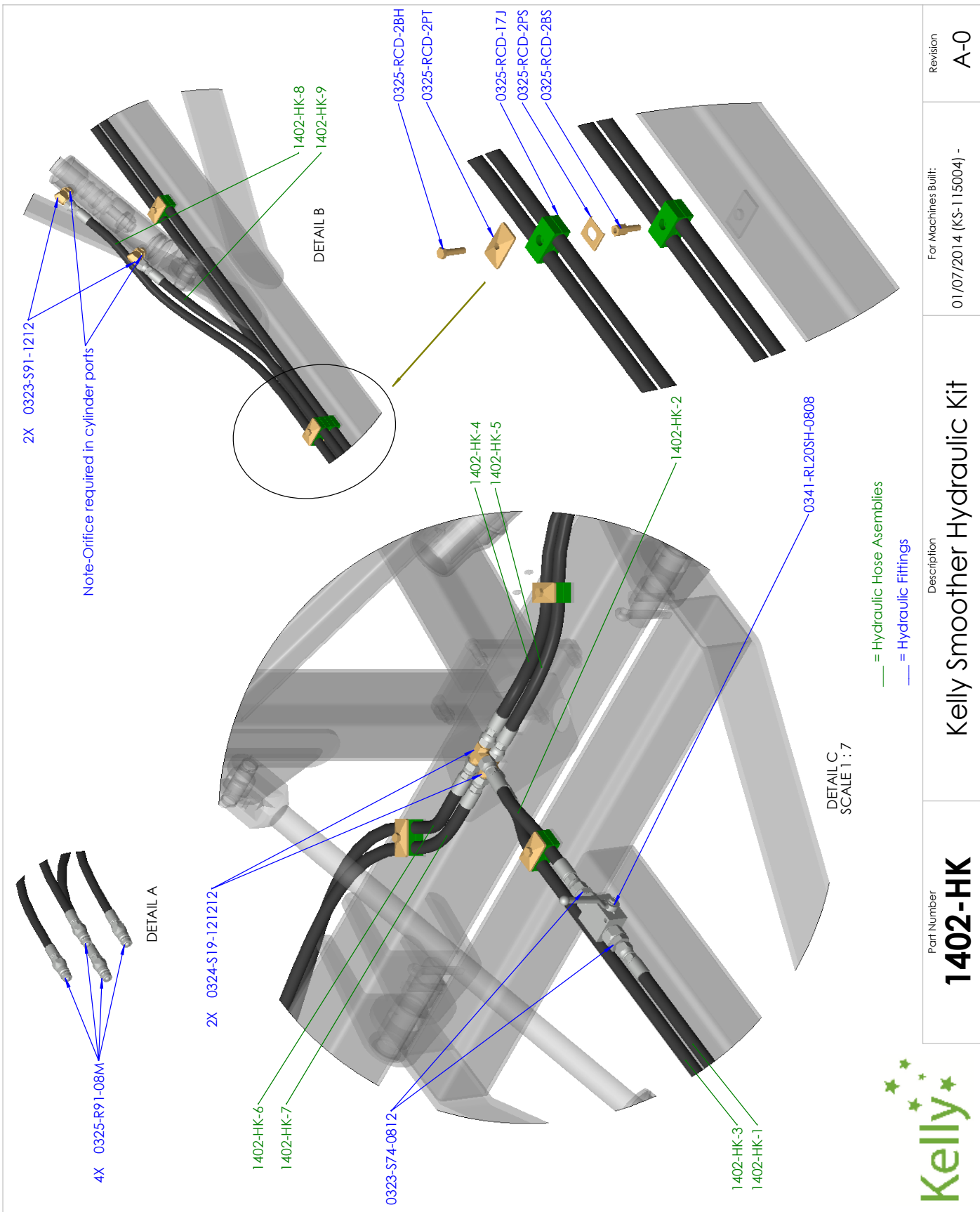

Revision
A-0

For Machines Built:
01/07/2014 (KS-115004) -

Description
Kelly Smoother Hydraulic Kit

Part Number
1402-HK



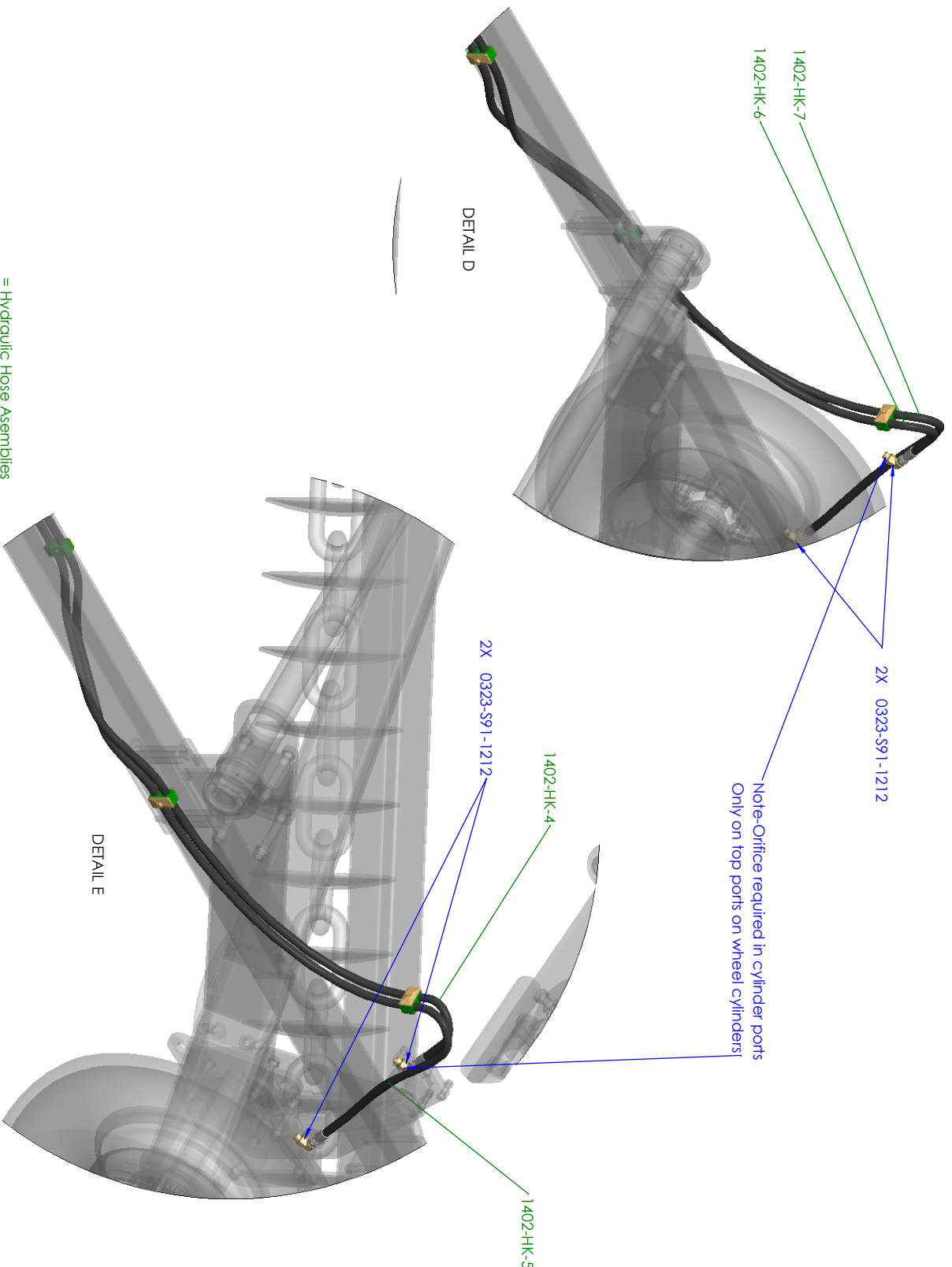

— = Hydraulic Hose Assemblies
 — = Hydraulic Fittings



Part Number	Description	For Machines Built:	Revision
1402-HK	Kelly Smoother Hydraulic Kit	01/07/2014 (KS-115004) -	A-0

Section 4

Electrical Setup

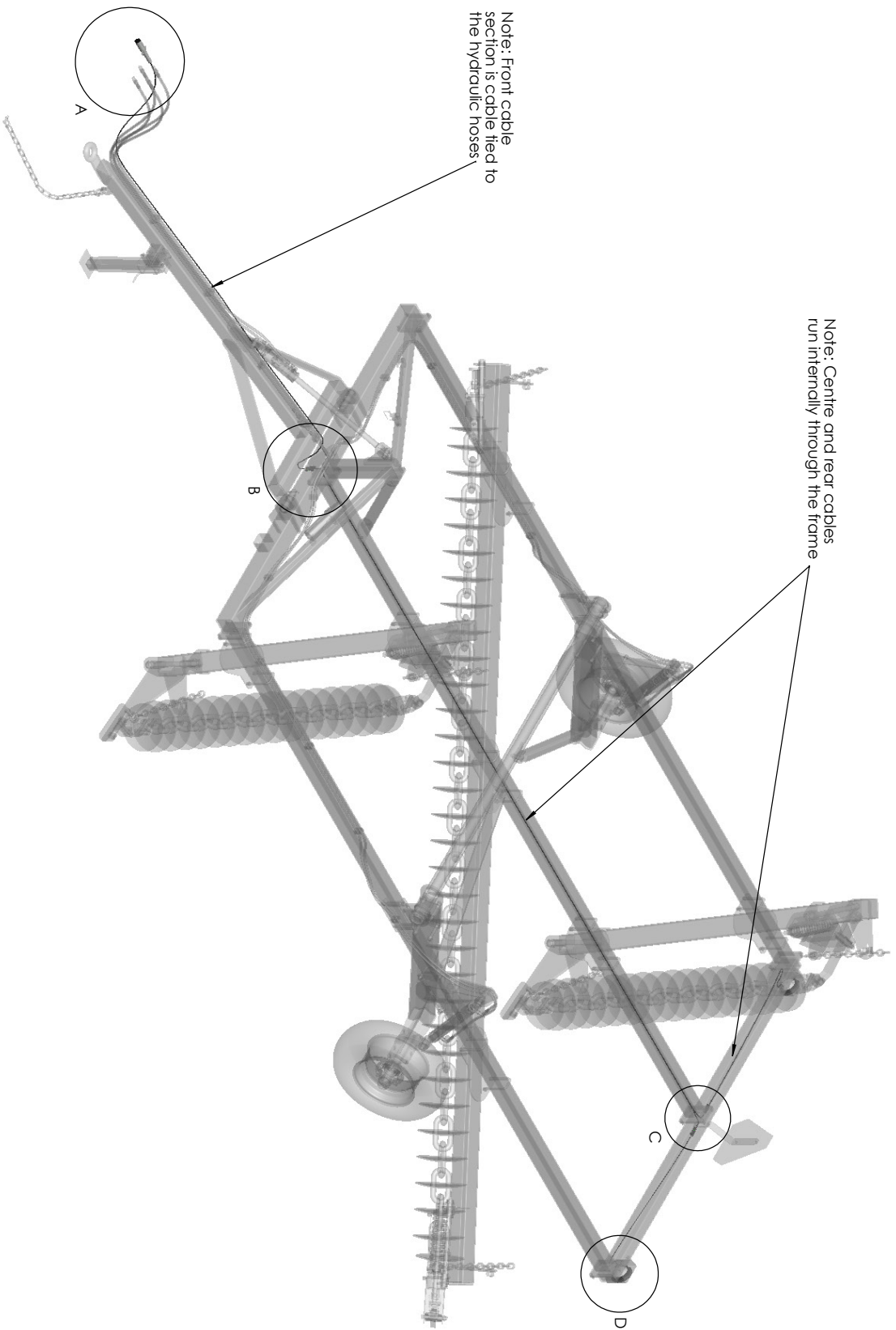

Part Number 1402-LK	Description Levee Reclaimer Light Kit	For Machines Built: 01/07/2014 (KS-115004) -	Revision B
-------------------------------	---	---	----------------------

0413-82194 (Heavy Duty 7 Pin Plug)

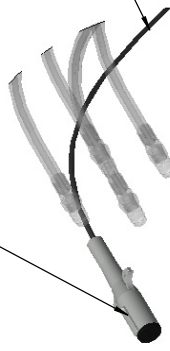

1402-LK-F (Front Section)

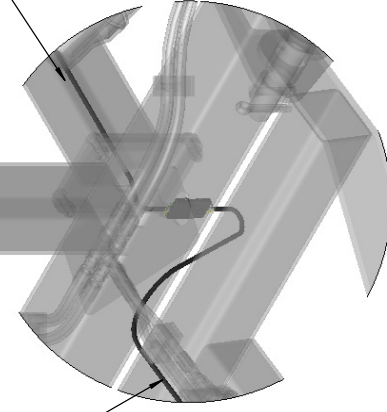

1402-LK-F (Front Section)

1402-LK-C (Centre Section)

DETAIL A

DETAIL B

1402-LK-RH (RH Section)

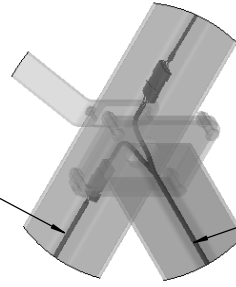

DETAIL C

1402-LK-C (Centre Section)

(LED Stop Tail Lamp) 0412-LED110RM

1402-LK-LH (LH Section)

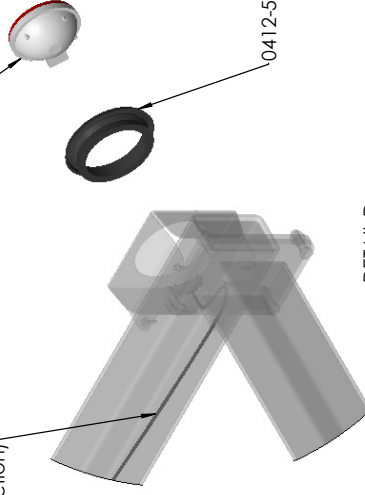

DETAIL D

0412-53101RG (110RM Rubber Grommet)



Part Number

1402-LK

Description

Levee Reclaimer Light Kit

For Machines Built:

01/07/2014 (KS-115004) -

Revision

B

Section 5

Decal Placement



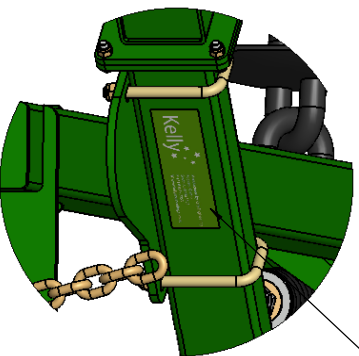

DETAIL I
SCALE 1 : 10

1401-DK-3
Kelly Smoother Decal - US Patents



DETAIL J
SCALE 1 : 10

1401-DK-7
Kelly Smoother Decal - Pinch Point

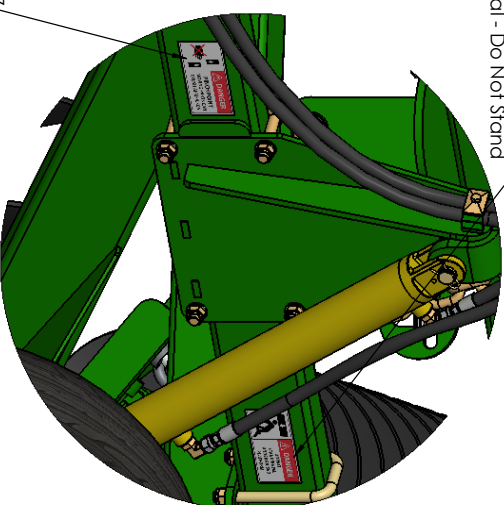

DETAIL L
SCALE 1 : 10

0801-S12
Decal - Kelly Engineering

1401-DK-8
Kelly Smoother Decal - Do Not Stand

1401-DK-2
Kelly Smoother Decal - Kelly Smoother

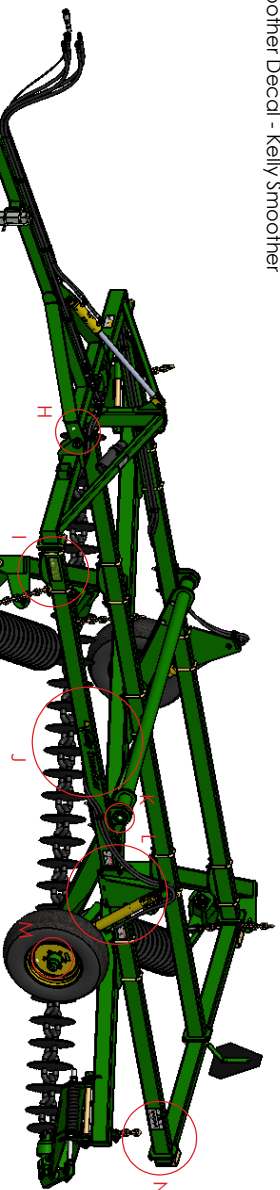

DETAIL K
SCALE 1 : 10

0801-S10
Decal - Grease

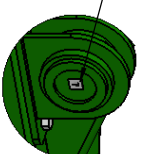

0801-S10
Decal - Grease

1401-DK-4
Kelly Smoother Decal - Chain Tension

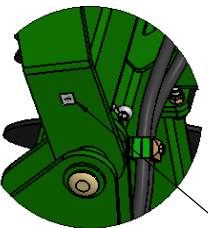

DETAIL H
SCALE 1 : 10

0801-S9
Decal - Wheel Nut

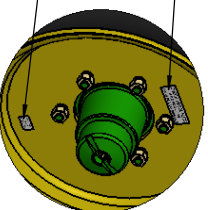

DETAIL M
SCALE 1 : 10

0801-S8-11L-15
Decal - 11L/15 Tyre Inflation

DETAIL N
SCALE 1 : 10

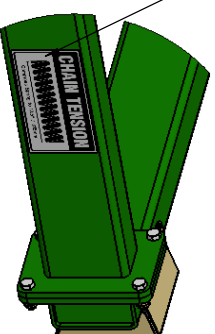

Kelly

Part Number
1402-DK

Description
Kelly Smoother Decal Kit

For Machines Built:
01/07/2014 (KS-115004)

Revision
A

Section 6

Operation

Operating speeds

Operating speeds for normal conditions	
Chain type	Speed
Prickle Chain	6-10 Mph / 10-16 kmph
Disc Mulch Chain	6-8 Mph / 10-12 kmph
Transport / towing on roads	15 Mph / 25 kmph

Tire pressure

Tire size	Ply	PSI	KPA
16.5L x 16.1	14	36	250
H40 x 14.5-19	26	60	410
11L - 15	10	44	300
15.5/80/24	16	58	400
16.5/85/24	16	55	380
550/60/22.5	16	40	280
400/60/22.5	16	50	350
12.5/80/18	14	85	590
15.0/70/18	14	71	490

Kelly Smoother specifications

Model	62'HDX
Working width	12' / 3.6m
Transport width	16' / 5m
Transport height	6' / 1.8m
Transport length	31' / 9.5m

Bolt Torque Settings

Bolt Type	Wheel nut				U Bolt			Grade 8.8 Bolt					Grade 10.9 Bolt	
	M18	M20	1/2"	9/16"	M10	M12	M16	M10	M12	M16	M20	M24	M20	M24
Ft lb	255	265	90	100	22	36	55	32	48	140	190	270	300	350
Nm	345	360	125	140	30	50	75	44	65	190	260	370	406	475

[1] When fitting a wheel & tire to a hub, tighten the wheel nuts in rotation to the correct tension. To achieve this choose a wheel nut & tighten, then proceed clockwise to the next wheel nut & tighten & so on until all wheel nuts are tight. Then repeat the procedure to check that all nuts are tight. Do not use impact tools to tighten wheel nuts. For a guide to the correct tension of the wheel nuts please use the appropriate tension for your size wheel nuts from the Bolt Torque Settings table.

Torque values are for dry threads and surfaces however it is permissible to apply a small amount of anti corrosive oil to the threads.

Chain Tension

Loosen the lock nut on the draw bolt.

Tighten the adjusting nut clockwise until the outer face of the spring retaining washer is flush with the body of the module tensioning unit. Retighten the lock nut.

If more than 8" (200mm) of thread is exposed then a link should be removed to maintain correct adjustment.

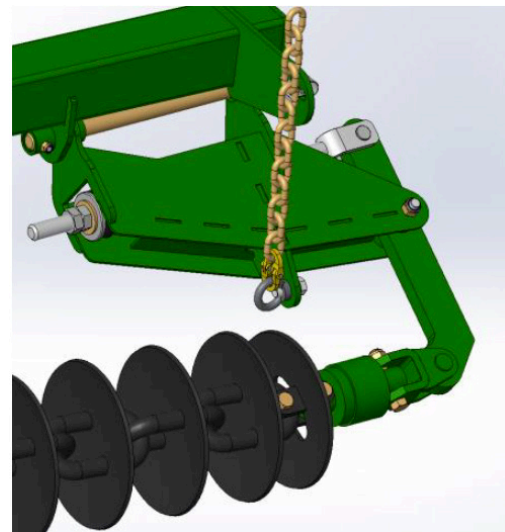
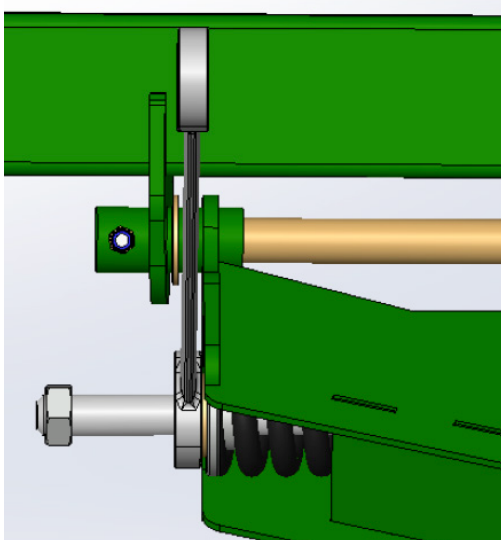
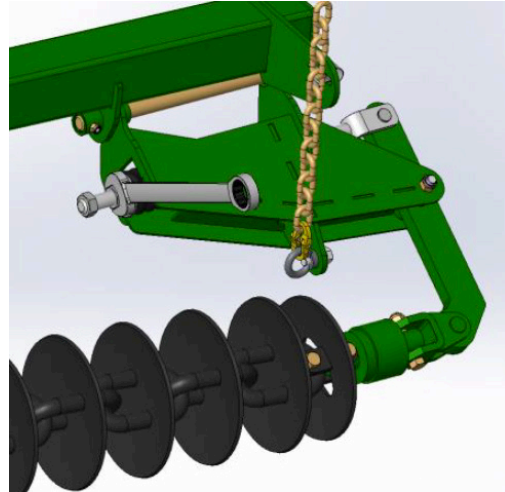
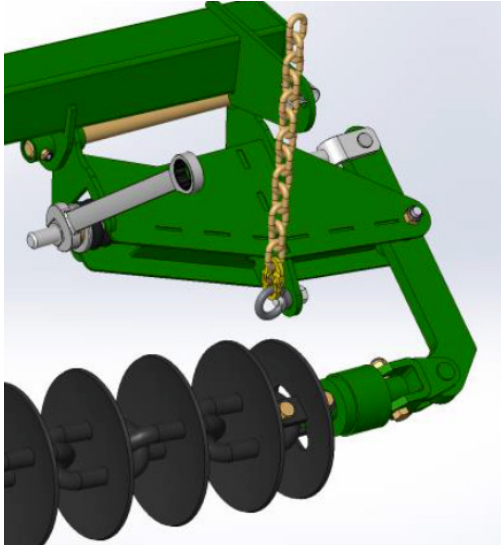

Importance of chain tension

Operational

It is imperative that the correct adjustment be maintained. Only through correct adjustment can a smooth and level finish be achieved in field working.

Loose chains lead to :

- Uneven performance across the width of the machine
- Uneven weed control
- Unsatisfactory incorporation
- Ineffective levelling
- Accelerated or premature chain wear
- Machine damage when folding or unfolding
- Uneven field surface with ridges and furrows being created.

Levee Smoother Axle Box Update

Page 1 of 6



Figure 1: Kelly Levee Smoother

The purpose of this document is to describe the replacement of the axle box assembly on the Kelly Levee Smoother (see above).

The upgrade involves removal of the current axle beam assemblies, and replacement with a set of components which have been supplied as part of kit 1410-AXLE KIT.

Removal of the current axle assemblies should be carried out as follows:

1. Ensure that the smoother frame is supported securely on appropriate trestles or stands
2. Remove both wheels and stub axles, and put aside for later use
3. Disconnect hydraulic hoses from lift cylinders, remove cylinders and put aside for later use
4. Unbolt and remove all components highlighted in Figure 2 (repeat for LH axle assembly). These components are no longer required (CAUTION – Heavy components. Ensure that safe lifting practices are employed)
5. Ensure that stub axle retaining bolt is kept for re-assembly

Levee Smoother Axle Box Update

Page 2 of 6

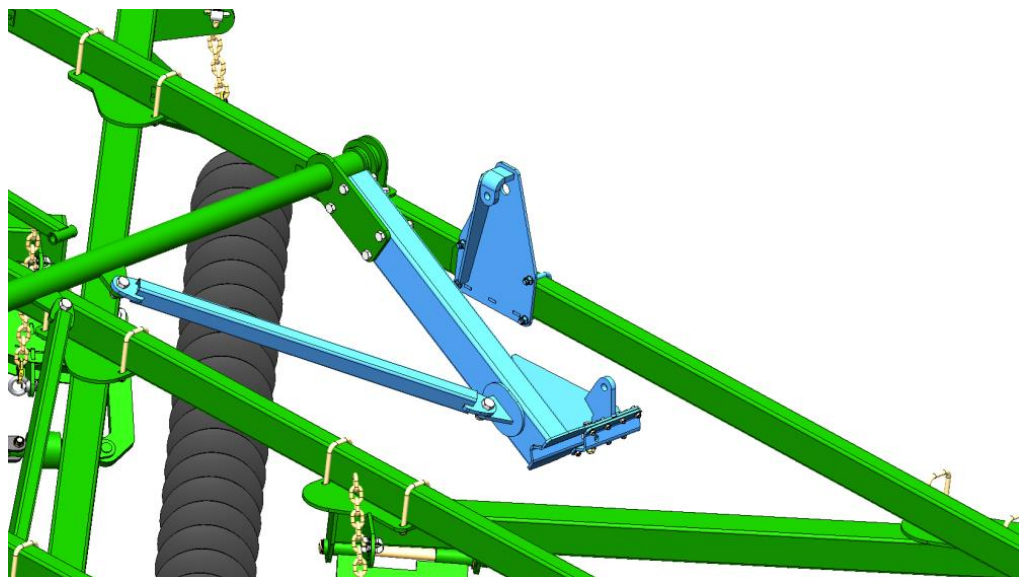

Figure 2: Components to be removed – RH axle assembly

The upgrade kit contains the following items:

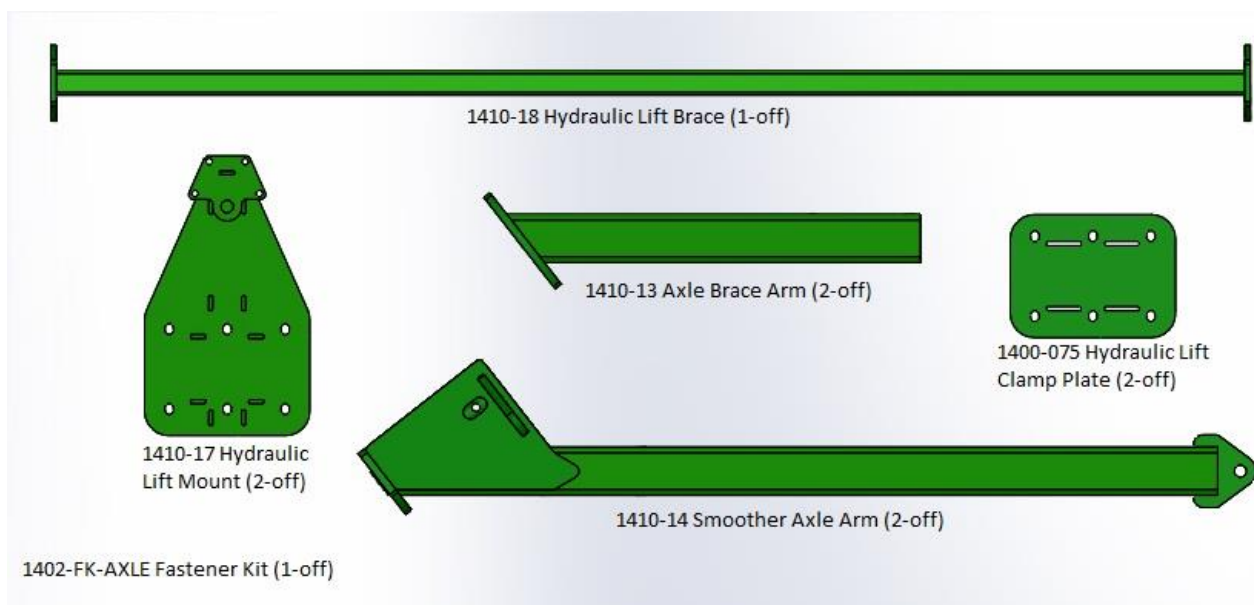

Figure 3: Contents of 1410-AXLE KIT

Levee Smoother Axle Box Update

Page 3 of 6

1. Attach the Smoother Axle Arms (1410-14) to the main Smoother Axle Beam as shown in Figure 3, using 2-off M24x65mm bolts – hand-tighten bolts only to allow for addition of further components.

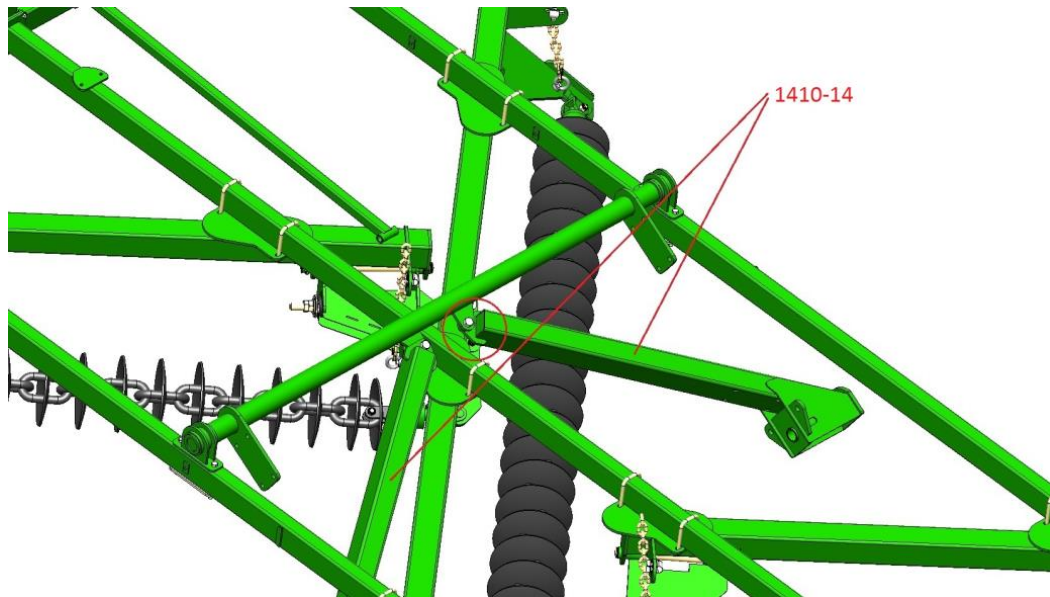

Figure 4: Addition of 1410-14 Smoother Axle Arms

NOTE: Left and Right Axle Arms are identical, but are mounted with lug above (LH) and below (RH) as shown in Figure 5.

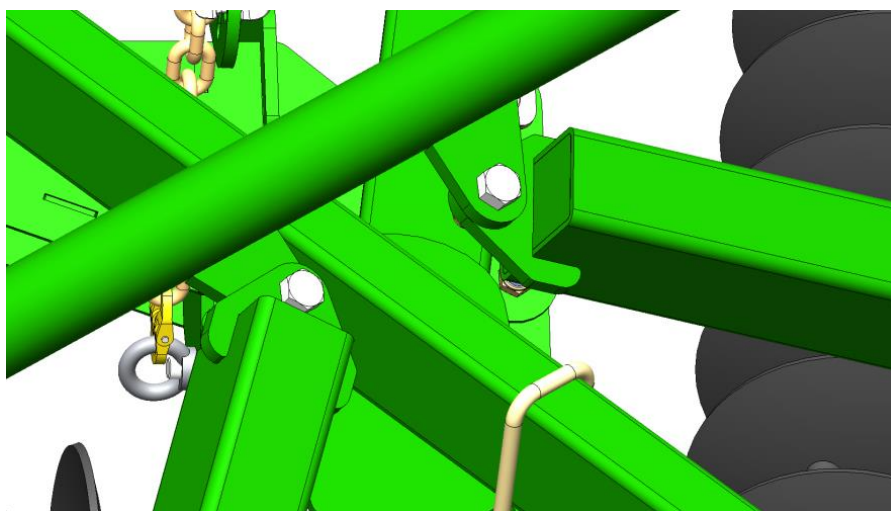

Figure 5: Detail showing lug position for LH/RH axle arm mounting of 1410-14

Levee Smoother Axle Box Update

Page 4 of 6

2. Attach Smoother Axle Brace (1410-13) to the Smoother Axle Beam and Smoother Axle Arm using 8-off M20x150 bolts. Repeat for left hand – attachment method is identical. Hand tighten only to allow for addition of further components.

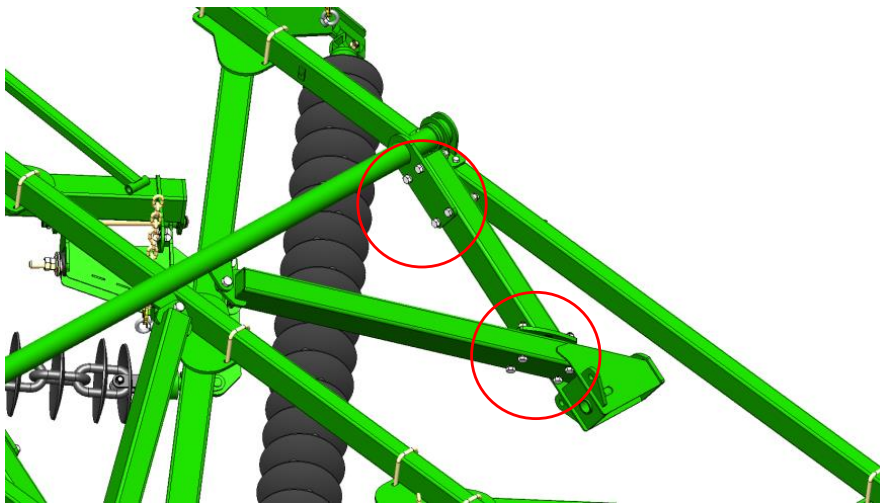

Figure 6: Attachment of Smoother Axle Brace 1410-13

3. Mount Hydraulic Lift Mount (1410-17), with the brace mount lugs facing inboard as shown in Figure 7. Using Hydraulic Lift Mount Clamp Plate 1400-075, bolt through with 6-off M16x20 bolts.

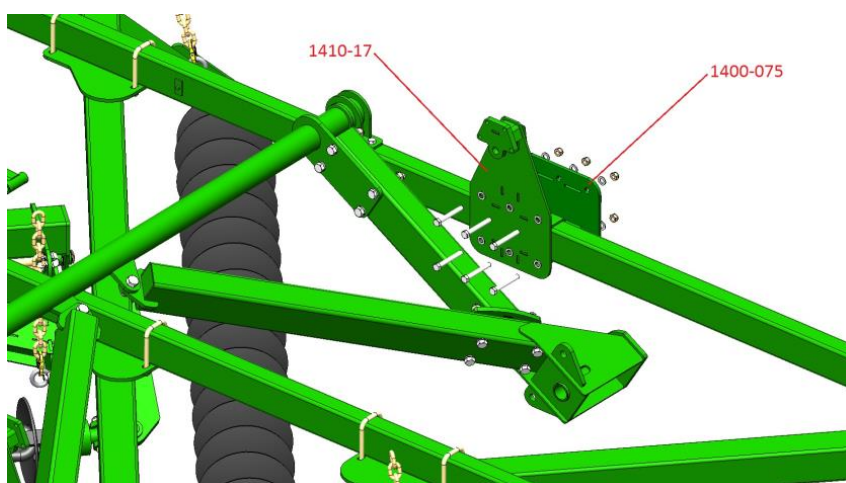

Figure 7: Attachment of Hydraulic Lift Mount 1410-17

Levee Smoother Axle Box Update

Page 5 of 6

Ensure that edge of Clamp Plate 1400-075 sits up against register plate on main beam, as shown in Figure 8. If this plate is not present, use the reference dimension shown for location purposes. Repeat for LH Hydraulic Lift assembly.

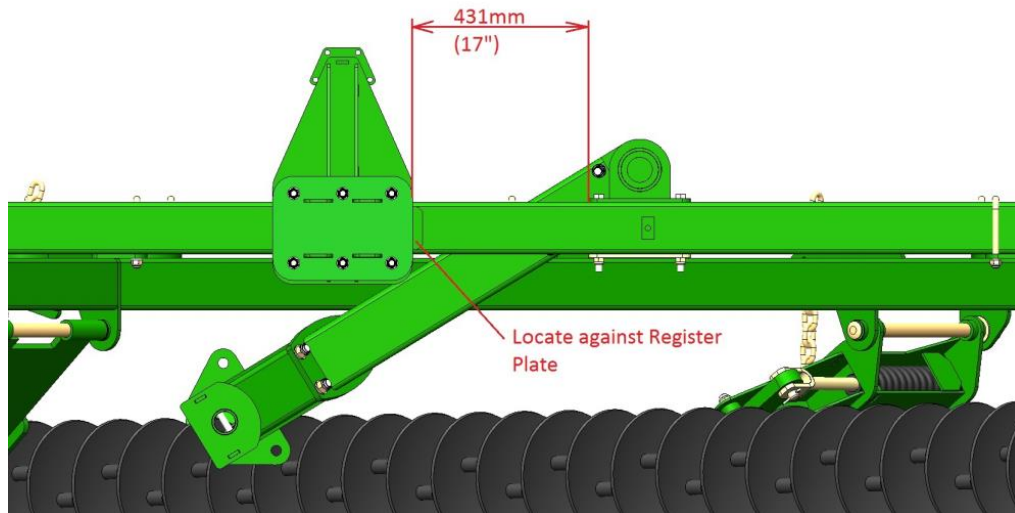

Figure 8: Register Plate and reference dimension for Hydraulic Lift location

4. Attach Hydraulic Lift Brace (1410-18) to LH and RH Hydraulic Lift Mounts using 8-off M12 x 45 bolts (see Figure 9).

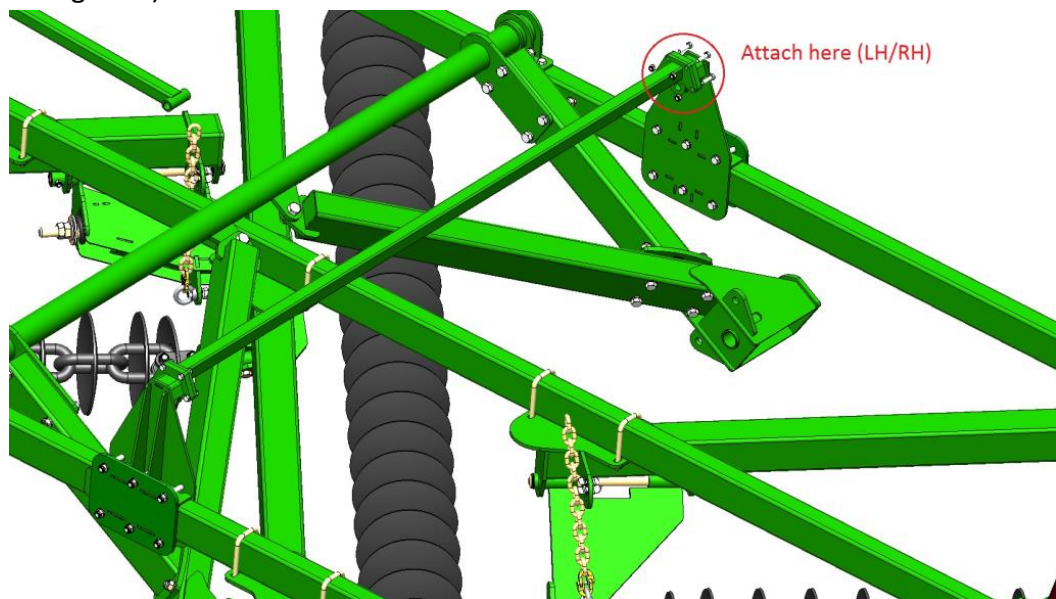

Figure 9: Mounting of Hydraulic Lift Brace (1410-18)

Levee Smoother Axle Box Update

Page 6 of 6

5. Re-attach hydraulic cylinders as shown in Figure 10, then fully tighten all fasteners. Re-attach hydraulic hoses, and ensure that hydraulic cylinders function correctly. Finally, re-attach stub axles and wheels, ensuring that stub axle retaining bolt is re-attached.

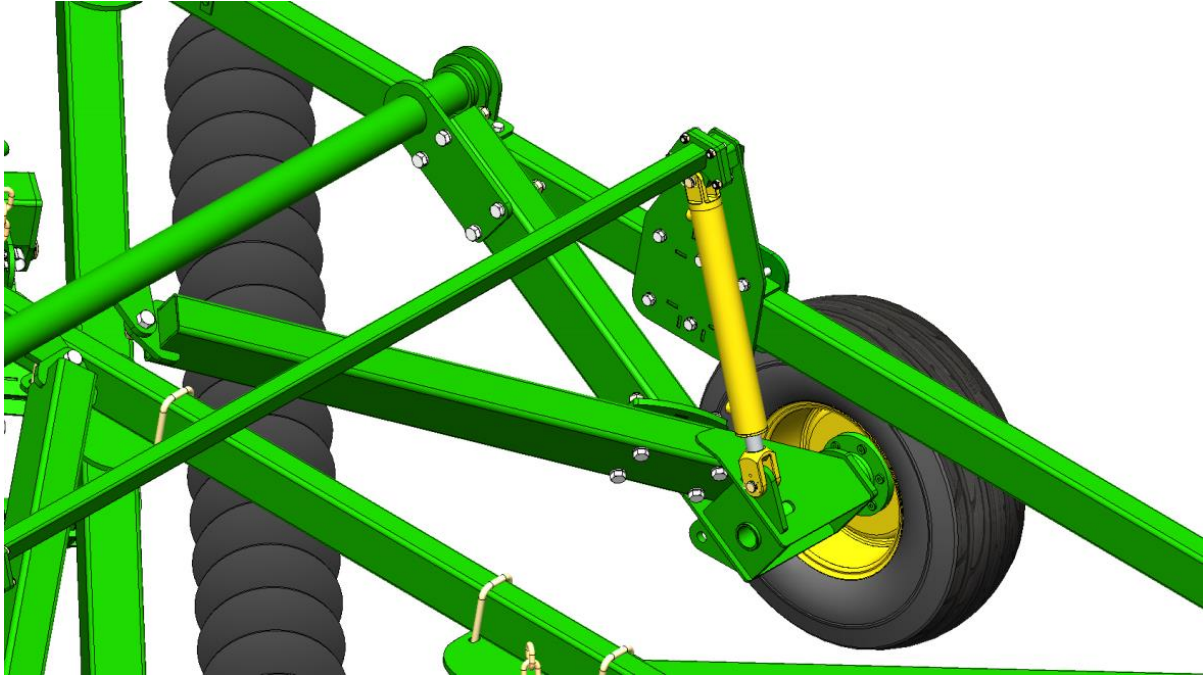

Figure 10: Attachment of cylinders, axles and wheels

