

KELLY

Better Tillage. Better Tomorrow.

Assembly Manual

KELLY TILLAGE SYSTEM 4012

KEASM-K-01012024

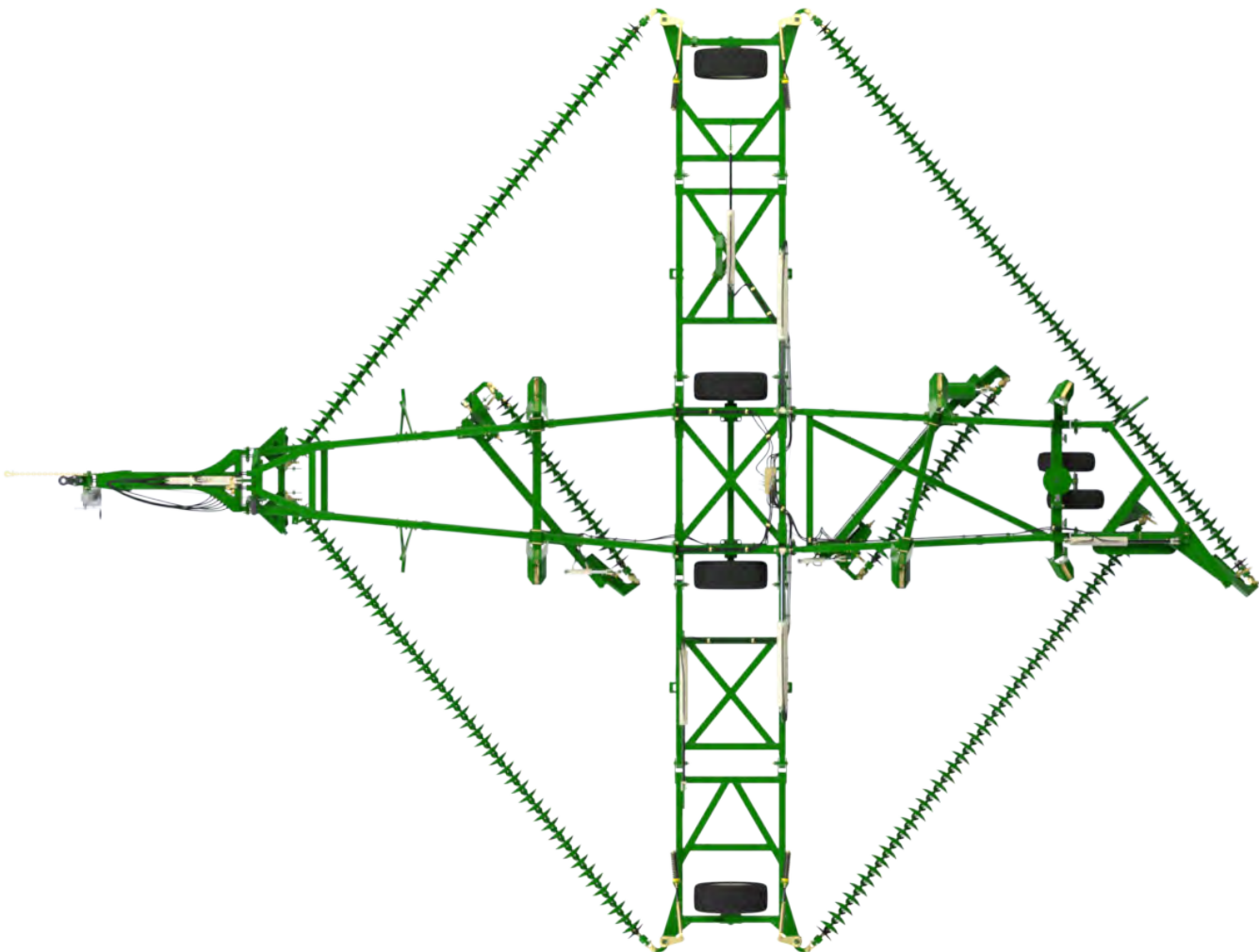

SERIAL NUMBER:

KELLY

Phone +61 8 8667 2253
Email sales@kellytillage.com
kellytillage.com

Booleroo (Head Office)
684 Kelly Road,
Booleroo Centre SA 5482

Adelaide Office
28 Greenhill Road,
Wayville SA 5034





Thank you for choosing a KELLY product.

We trust that you find the following manual clear and easy to follow. If you should require additional customer support or assistance, please do not hesitate to contact us.

Spare parts can be purchased, as required, through your local dealer or by contacting KELLY directly.

The KELLY team values your feedback. Should you have any difficulties that you wish to raise, suggestions for improvement or modifications that you feel would enhance our products we look forward to hearing from you.

Contact Us

Australia

Booleroo (Head Office)

684 Kelly Road,
Booleroo Centre SA 5482

+61 8 8667 2253

Monday - Friday
8am - 4pm ACDT

Adelaide Office

28 Greenhill Road,
Wayville SA 5034

+61 8 8667 2253

Monday - Friday
8am - 4pm ACDT

Global Locations

Eastern Canada

Leading Edge Equipment
www.leadingedgeequipment.ca

1-519-421-3223

Monday - Friday
8am - 4pm EST

Western Canada

Adair Sales & Marketing Co Inc
www.adairreps.com

1-306-773-0996

Monday - Friday
8am - 5pm CST

United States

Hood & Company

+1 417-865-2100

Monday - Friday
8am - 4pm CST

Europe

kellytillage.com

+61 8 8667 2253

Monday - Friday
8am - 4pm ACDT

Argentina

Giorgi Sa Maquinarias Agrícolas
www.giorgi.com.ar

+54 3464 493512

Monday - Friday
8am - 5pm ART

South Africa

Desmond Whitfield CC

+27 82 567 8245

Monday - Friday
8am - 4pm SAST

Contents

Section 1 - Unpacking	4
Section 2 - Assembly	6
Section 3 - Decal Application	131
Section 4 - Light Kit	152
Section 5 - Chain Assembly	165
Section 6 - Specification	176
Section 7 - Operation	180
Notes	184

Legend



This symbol indicates which bag the relevant fasteners are in.



This symbol indicates which bag the relevant hydraulics are in.

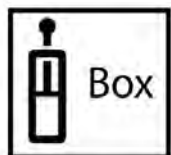

This symbol indicates the hydraulics are in a box.



This symbol indicates which way the machine is travelling.



Section 1 - Unpacking



CAUTION

Before cutting straps attach slings or chains and take the weight of the frames to avoid them slipping or falling and causing injury.



CAUTION

Wear eye and hand protection when cutting straps. Sharp edges are exposed as straps separate and may cause injury.



CAUTION

To avoid falling or moving components, before cutting straps attach slings or chains to individual pieces and only cut the straps holding the piece to be lifted.

- Remove boxes from rear of container one at a time using a forklift truck. Each box weighs approximately 5512 lbs (2500 kg)
- Cut straps holding bundles and separate parts and place in assembly area
- Once all parts have been identified, the machine is ready for assembly
- Identify parts for each machine by serial no. or description and separate. Open parts box and check that all parts are accounted for against checklist
- Read assembly instructions before proceeding.

NOTE

The hubs show below are interchangeable (refer to page 37, 38 or 40 for assembly).

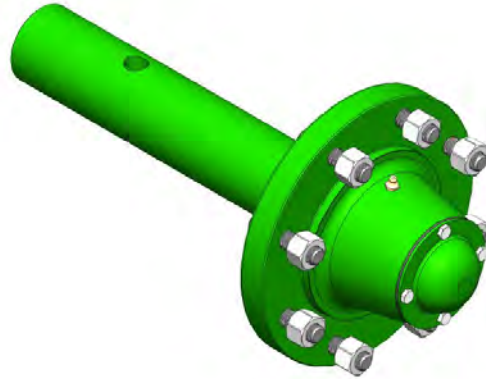

0733-LG6080067

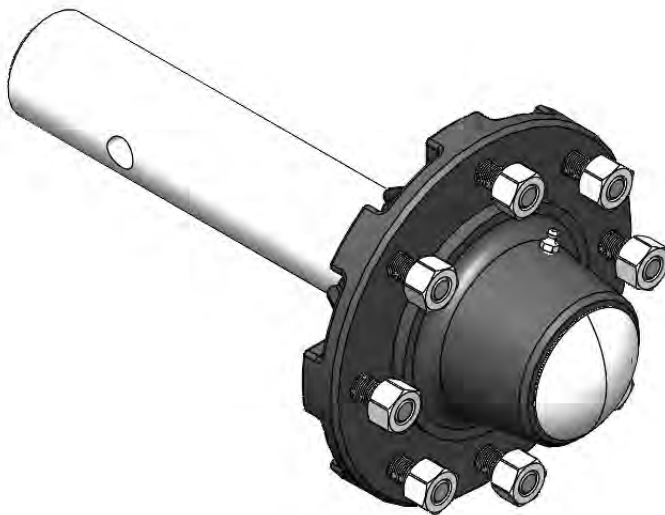

0733-N281089L18.74

KELLY

Section 2 - Assembly

Item No.	Description	Qty	Number
1	40' Centre Frame	1	1540-01-1

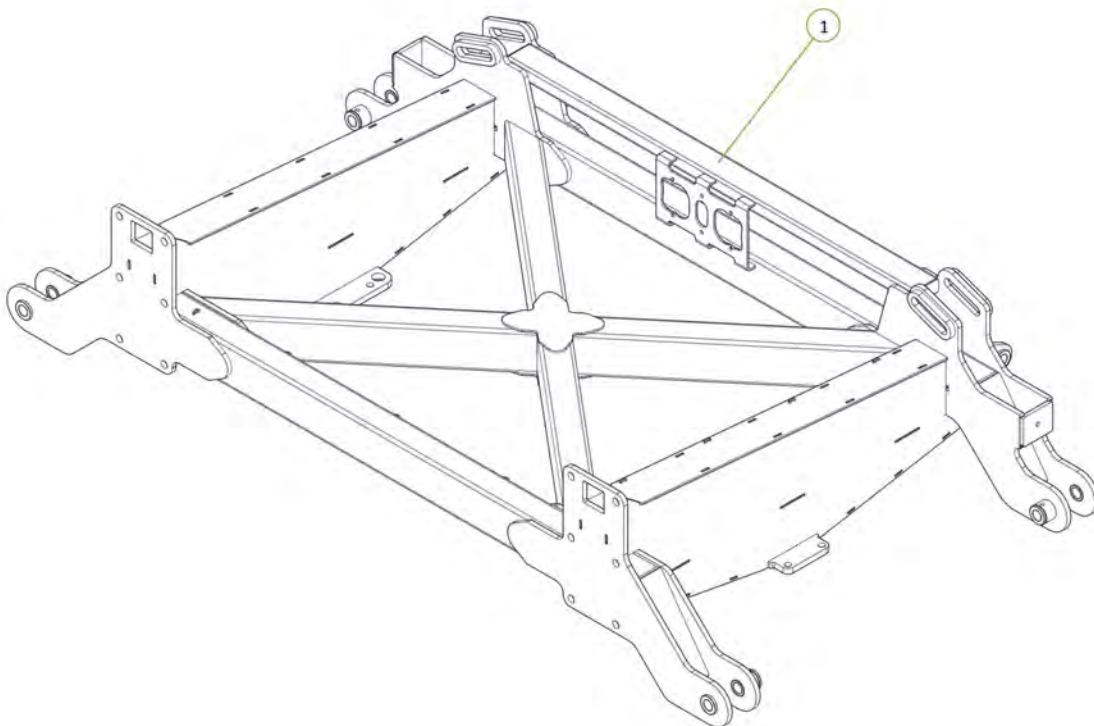

Item No.	Description	Qty	Number
1	Wing Folding Buffer	2	1201-12
2	M16 x 60 grade 8.8 zp Bolt	2	0211-1660
3	Nyloc Nut M16	2	0221-NYL16
4	Washer Flat M16	4	0231-F16

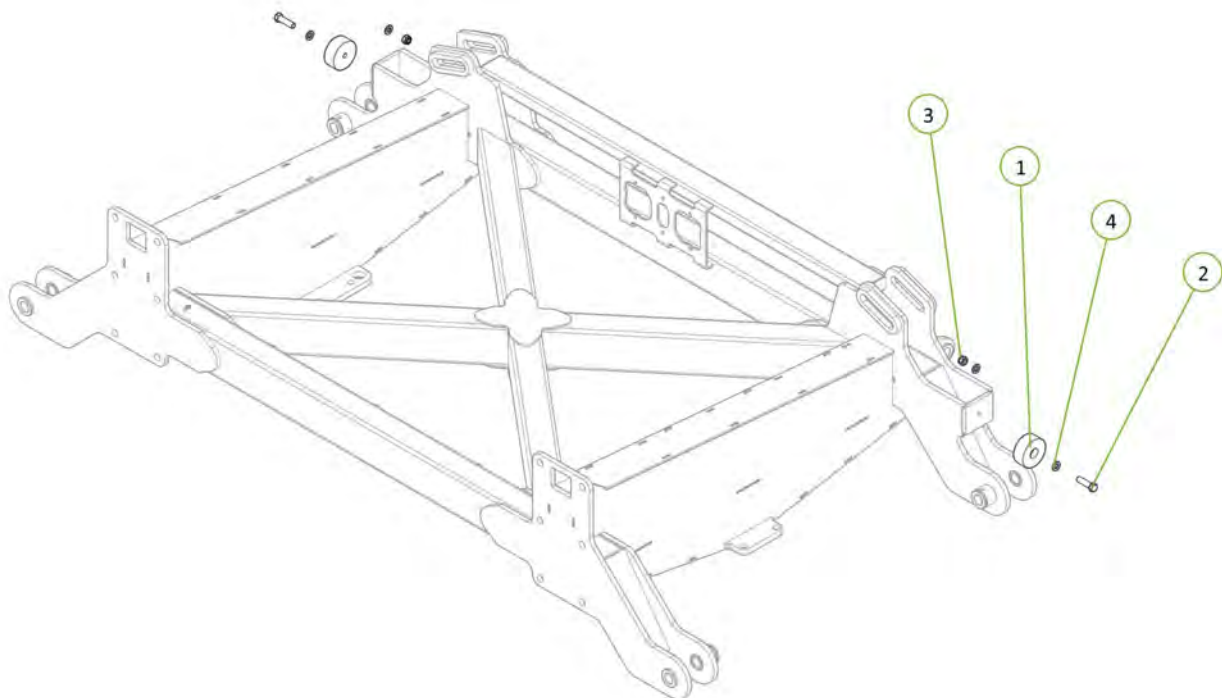

Item No.	Description	Qty	Number
1	Left Hand Inner Wing	1	1540-05-4
2	35 ID x 30mm DU Bush	4	0113-MB3530DU
3	PCH Wing Pivot Pin	2	0801-10-08-235
4	M12 x 90 Class 8.8 ZP Bolt	2	0211-1290
5	Nyloc Nut M12	2	0221-NYL12
6	Cotter Pin M13 x 63	2	0261-PINC1363

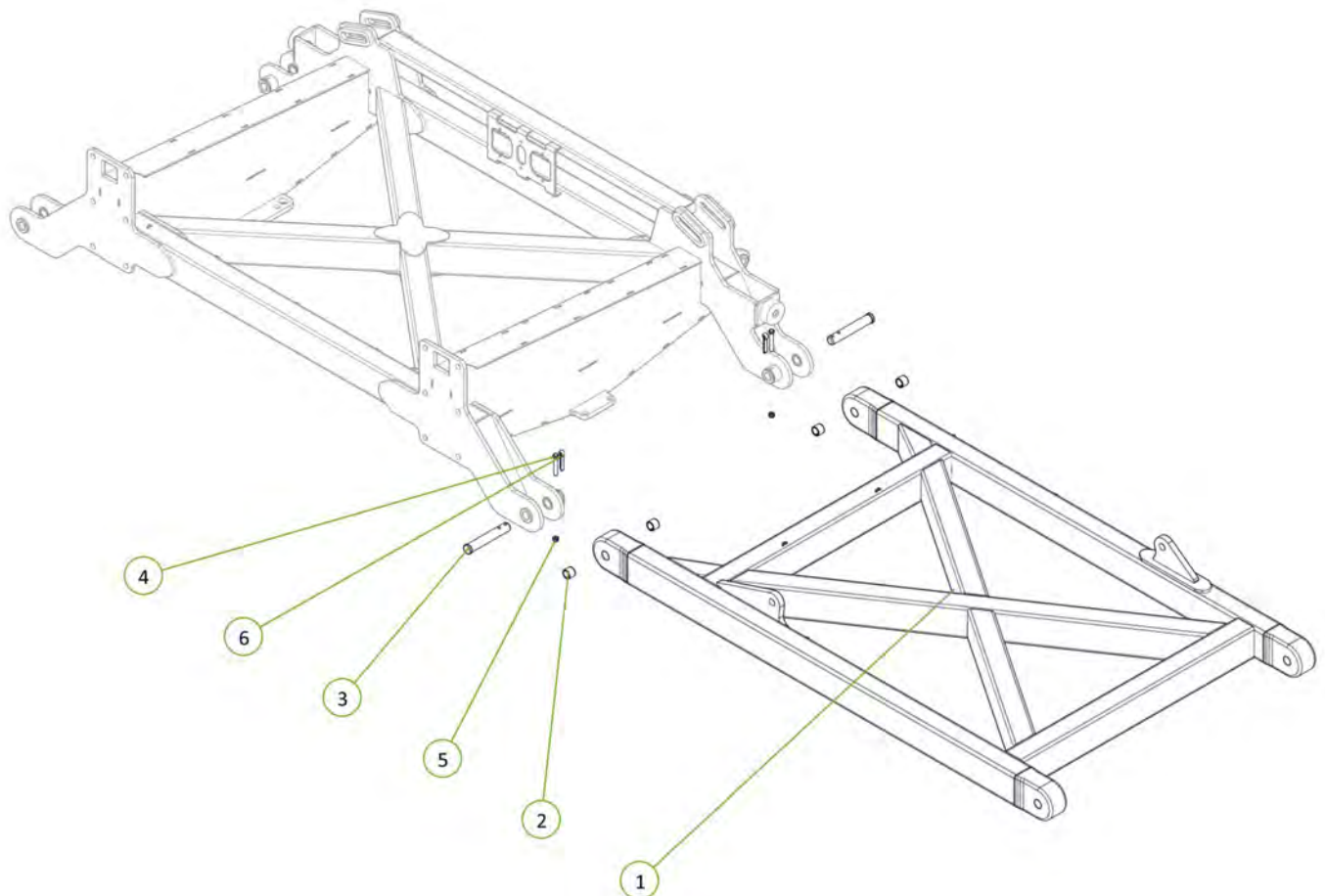

Item No.	Description	Qty	Number
1	40' LH Outer Wing	1	1540-07-2
2	35 ID x 30mm DU Bush	4	0113-MB3530DU
3	PCH Wing Pivot Pin	2	0801-10-08-235
4	Cotter Pin M13 x 63	2	0261-PINC1363
5	M12 x 90 Class 8.8 ZP Bolt	2	0211-1290
6	Nyloc Nut M12	2	0221-NYL12

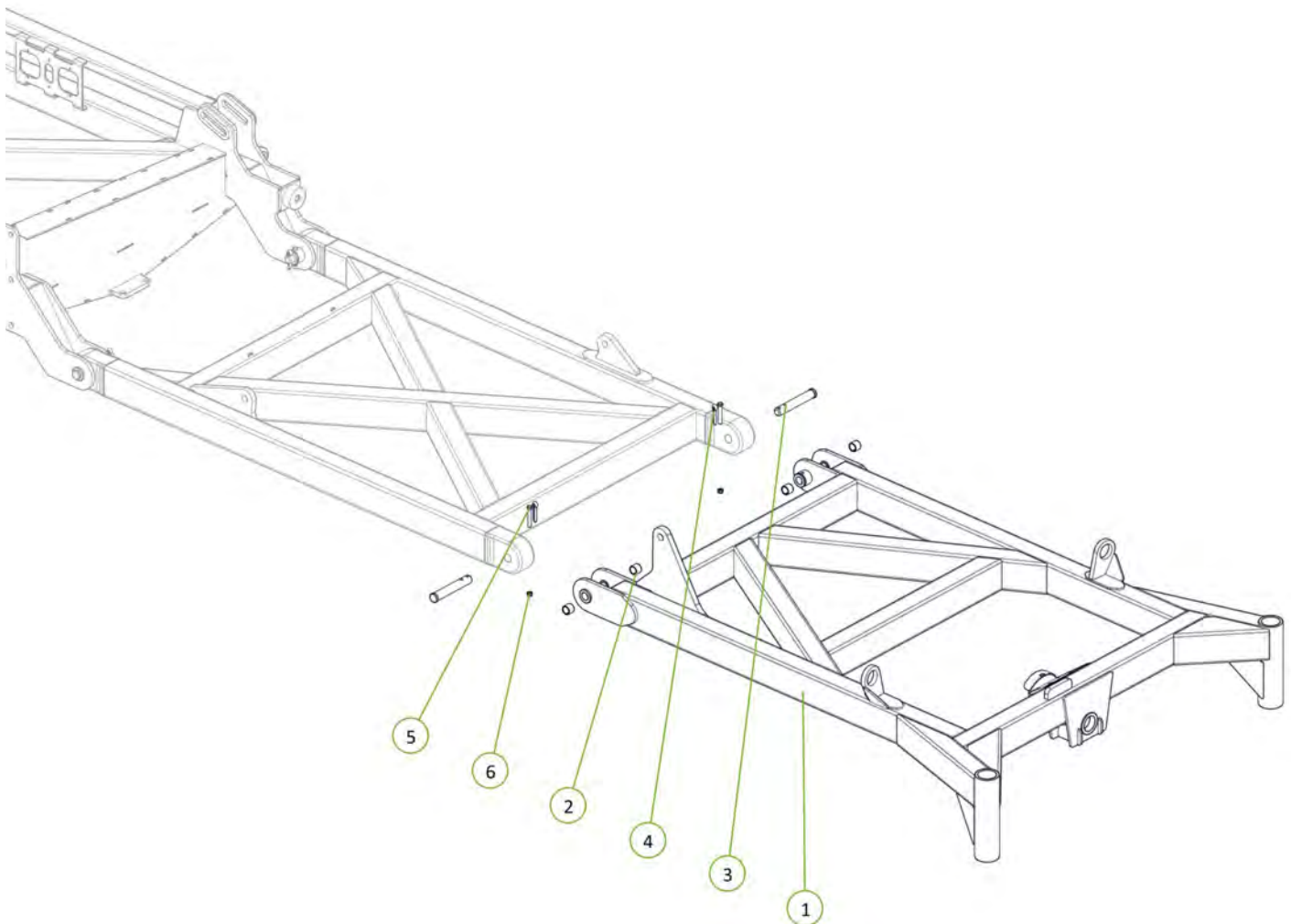

Item No.	Description	Qty	Number
1	Right Hand Inner Wing	1	1540-04-4
2	PCH Wing Pivot Pin	2	0801-10-08-235
3	Cotter Pin M13 x 63	2	0261-PINC1363
4	M12 x 90 Class 8.8 ZP Bolt	2	0211-1290
5	Nyloc Nut M12	2	0221-NYL12
6	35 ID x 30mm DU Bush	4	0113-MB3530DU
7	Inner Wing Post	1	1510-274
8	U-Bolt M16 x 185 Deep x 104 Wide	4	0271-16185104
9	Nyloc Nut M16	8	0221-NYL16
10	Washer Flat M16	8	0231-F16

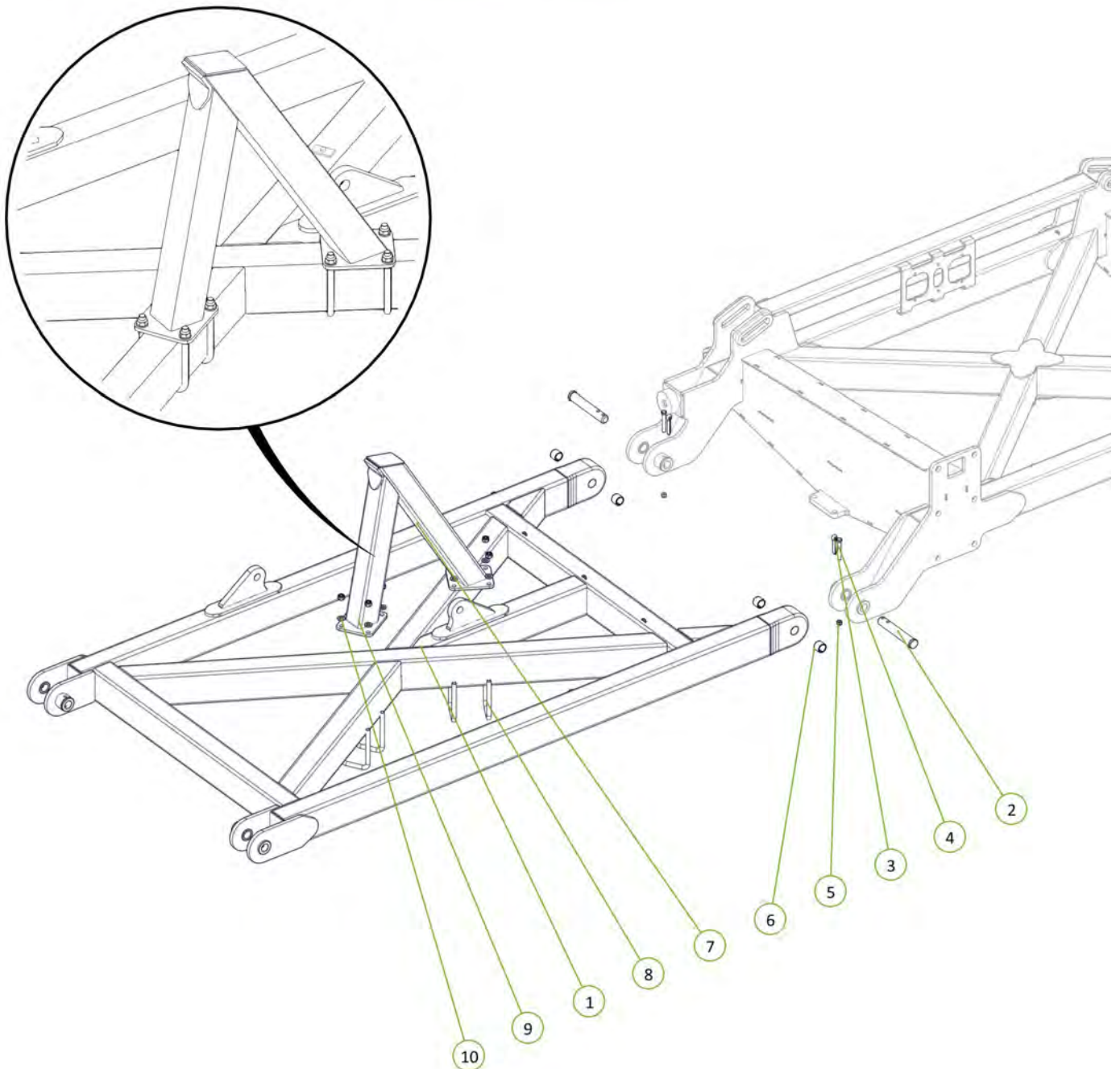
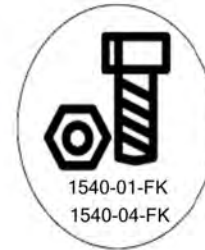

Item No.	Description	Qty	Number
1	Right Hand Outer Wing	1	1540-06-3
2	M12 x 90 Class 8.8 ZP Bolt	2	0211-1290
3	PCH Wing Pivot Pin	2	0801-10-08-235
4	Cotter Pin M13 x 63	2	0261-PINC1363
5	35 ID x 30mm DU Bush	4	0113-MB3530DU
6	Nyloc Nut M12	2	0221-NYL12
7	Right Hand Outer Wing Post	1	1510-241
8	U-Bolt M16 x 190 Deep x 106 Wide	2	0271-16185104
9	Nyloc Nut M16	4	0221-NYL16
10	Washer Flat M16	4	0231-F16

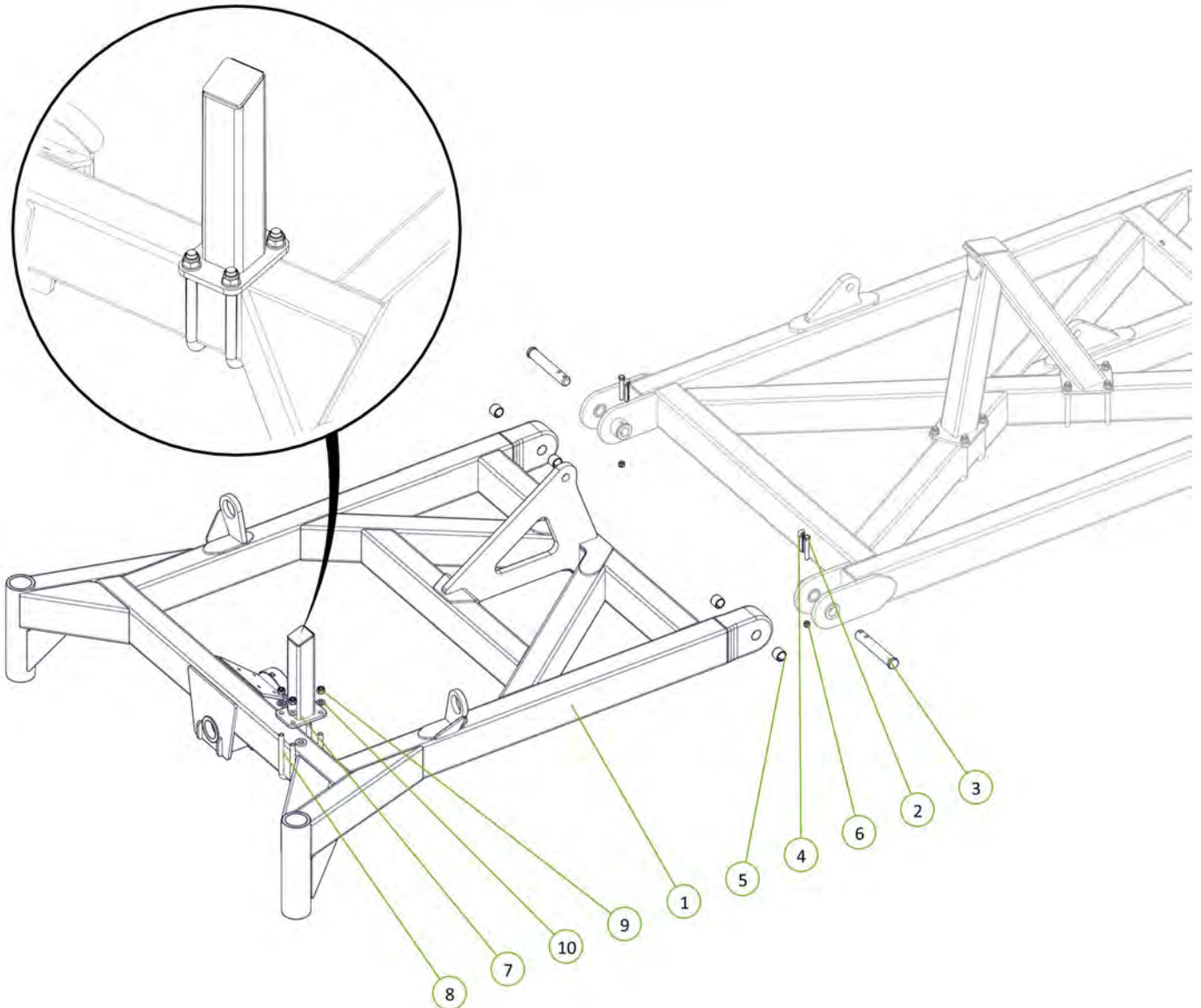

Item No.	Description	Qty	Number
1	Dual Circuit 3 Stage Sequence Manifold V12.5	1	0802-692196
2	M10 x 30 grade 8.8 ZP Bolt	6	0211-1035
3	Washer Spring M10	6	0231-S10
4	Washer Flat M10	6	0231-F10

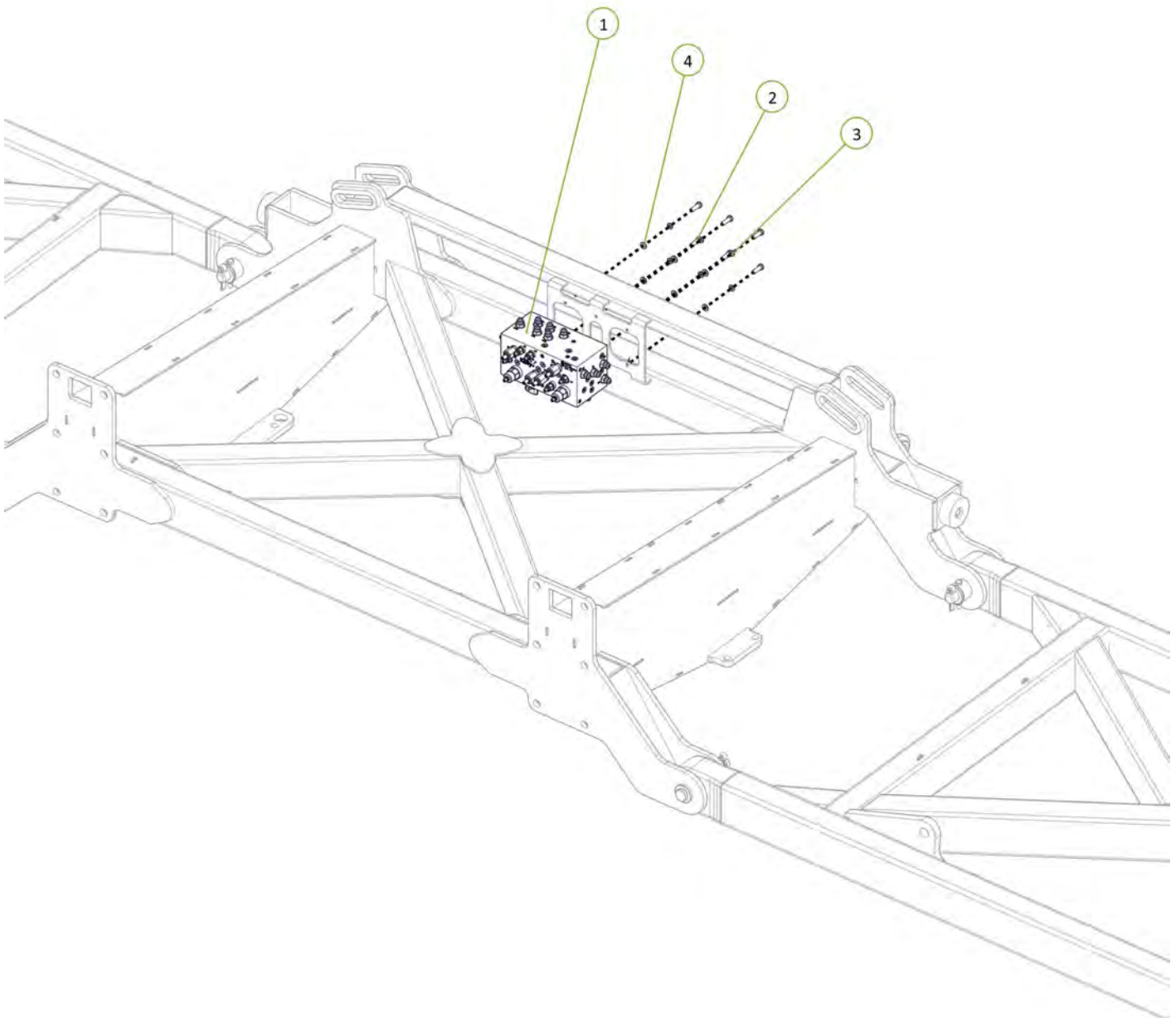

Item No.	Description	Qty	Number
1	5" Bore 36" Stroke 3 1/8" S/Tube 2" Rod Hydraulic Cylinder	1	0311-536ST

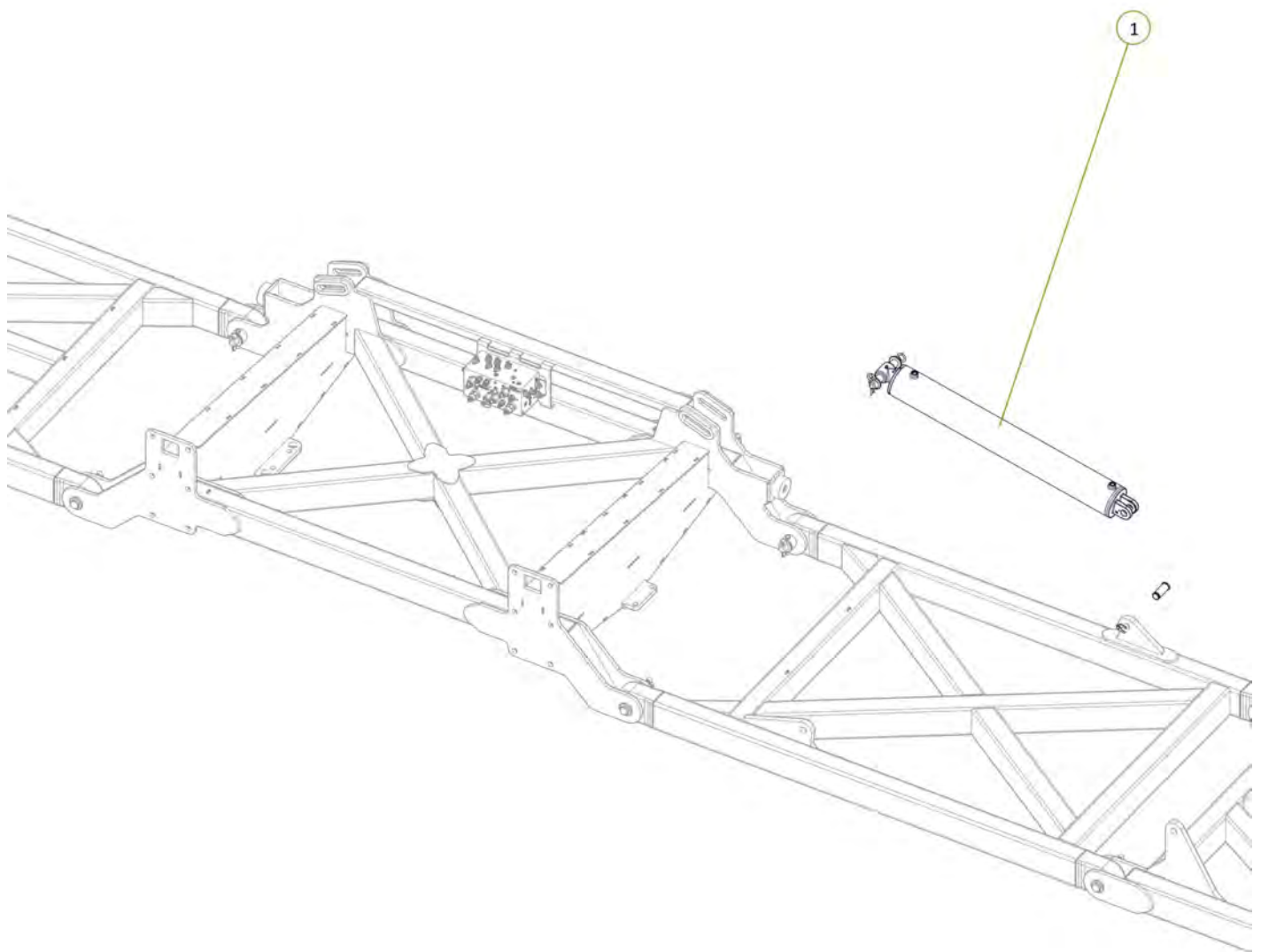

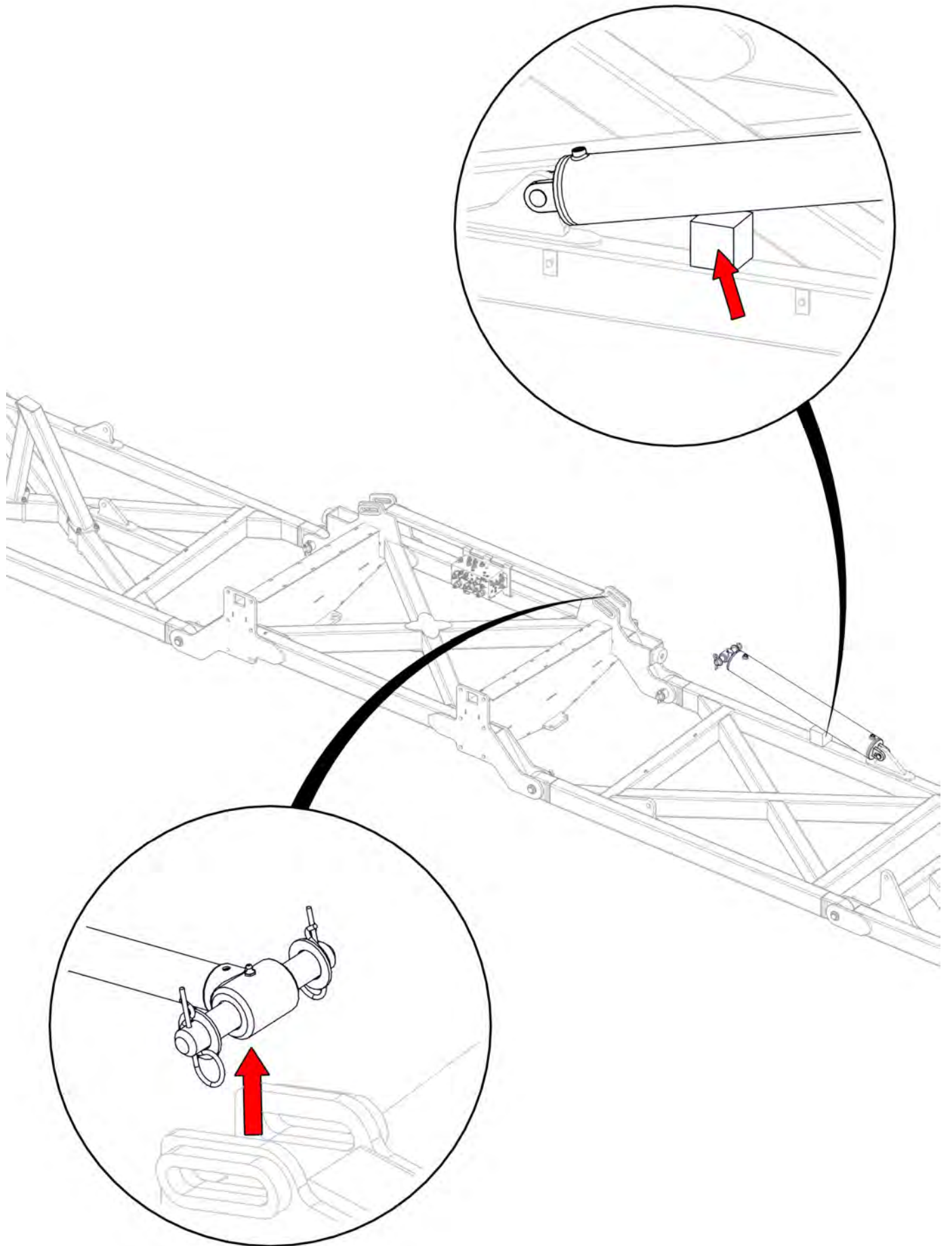

Item No.	Description	Qty	Number
1	3/4" JIC Male 3/4" UN O Ring Male 90° Elbow	2	0323-S91-1212

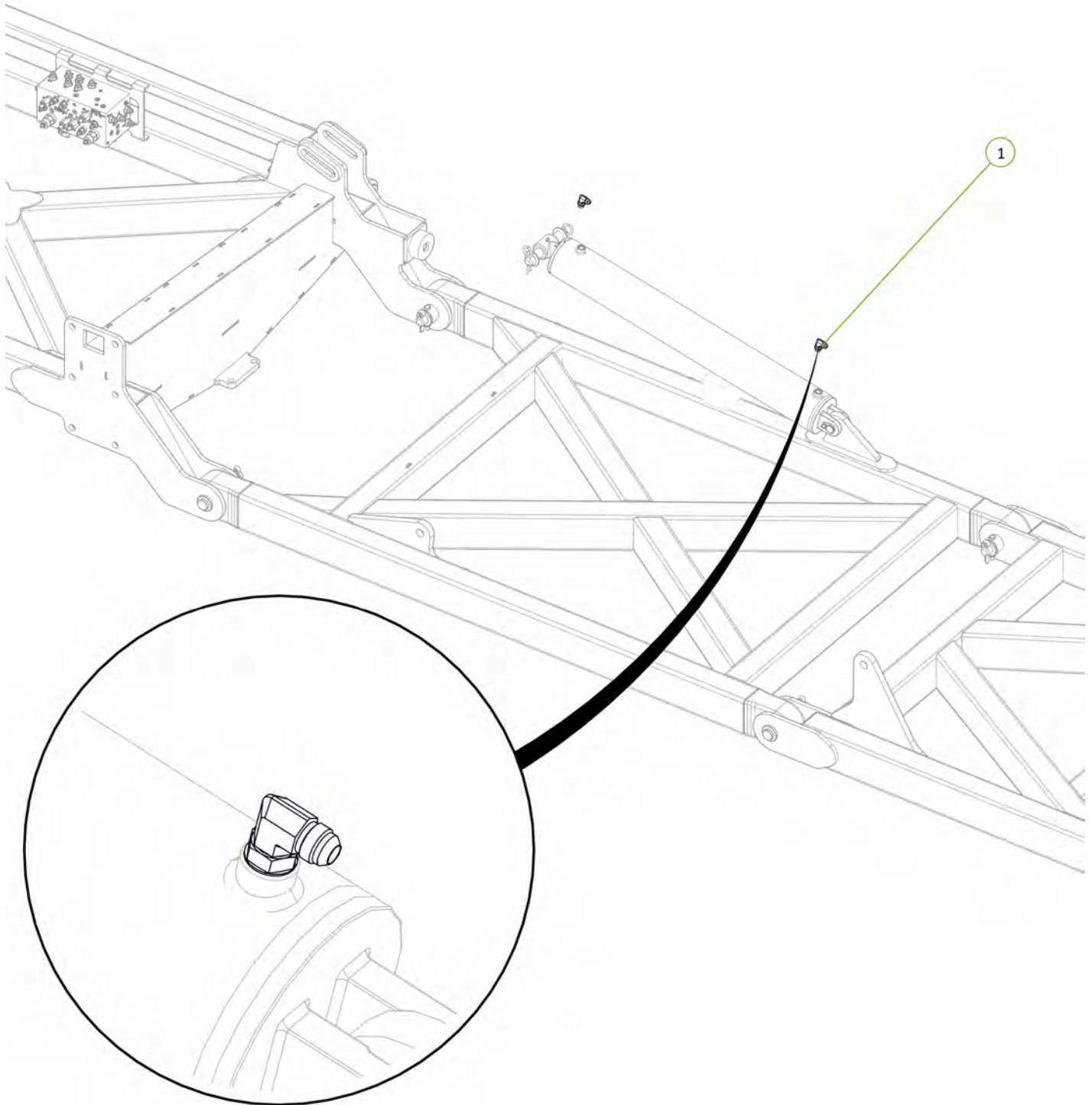

Item No.	Description	Qty	Number
1	Double Clamp Bolt Group 2	1	0325-RCD-2BH
2	Clamp top plate group 2	1	0325-RCD-2PT
3	17mm Clamp Jaws (Pair)	2	0325-RCD-17J
4	Double Clamp Stacking Plate (Non Ryco)	1	0325-SI-2-5D-W3
5	Double Clamp Stacking Bolt Group 2	1	0325-RCD-2BS

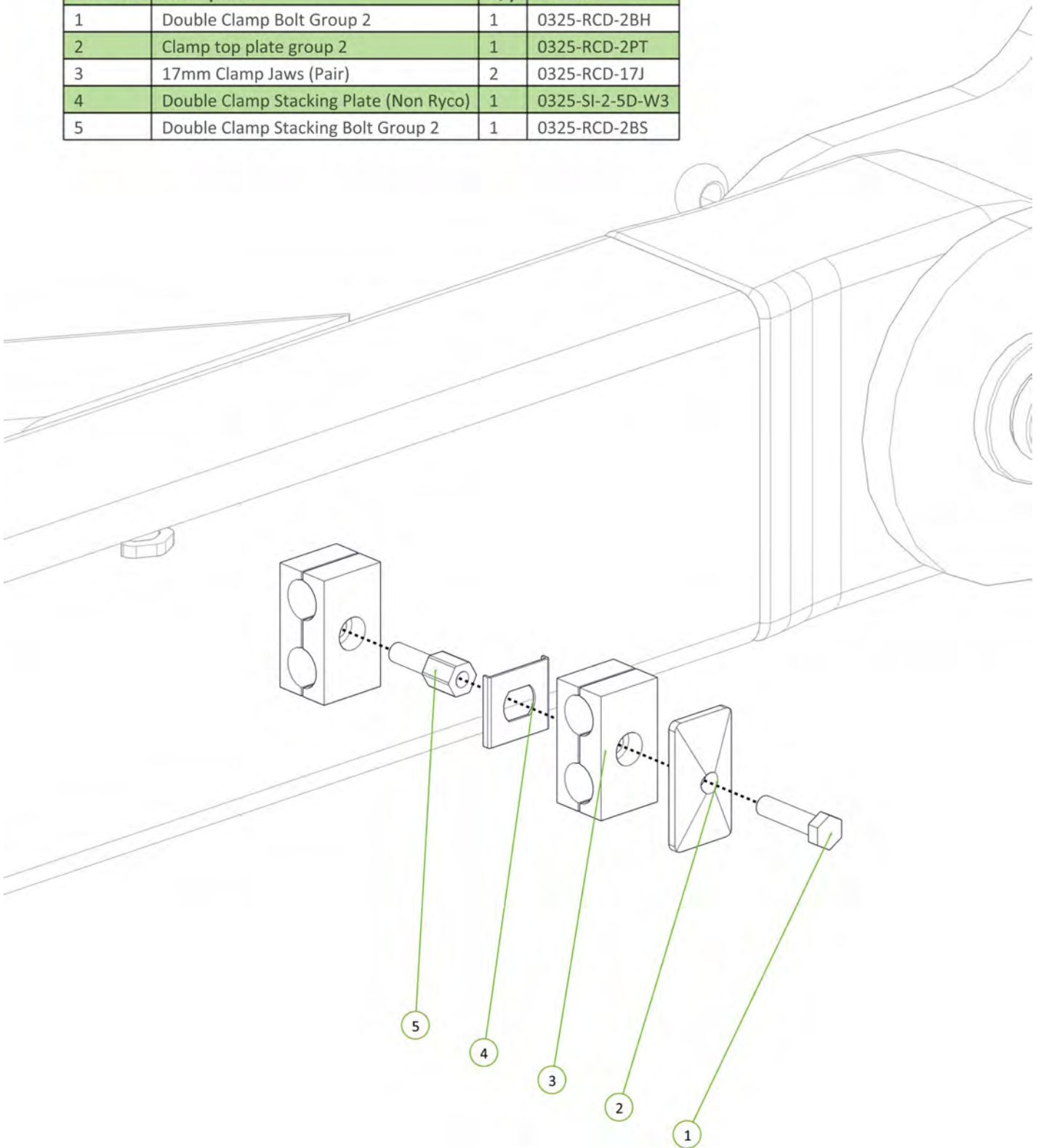

Item No.	Description	Qty	Number
1	Left CE Port to LH Main Wing Cylinder Extend Port	1	H12-17
2	Left CR Port to LH Main Wing Cylinder Retract Port	1	H12-18

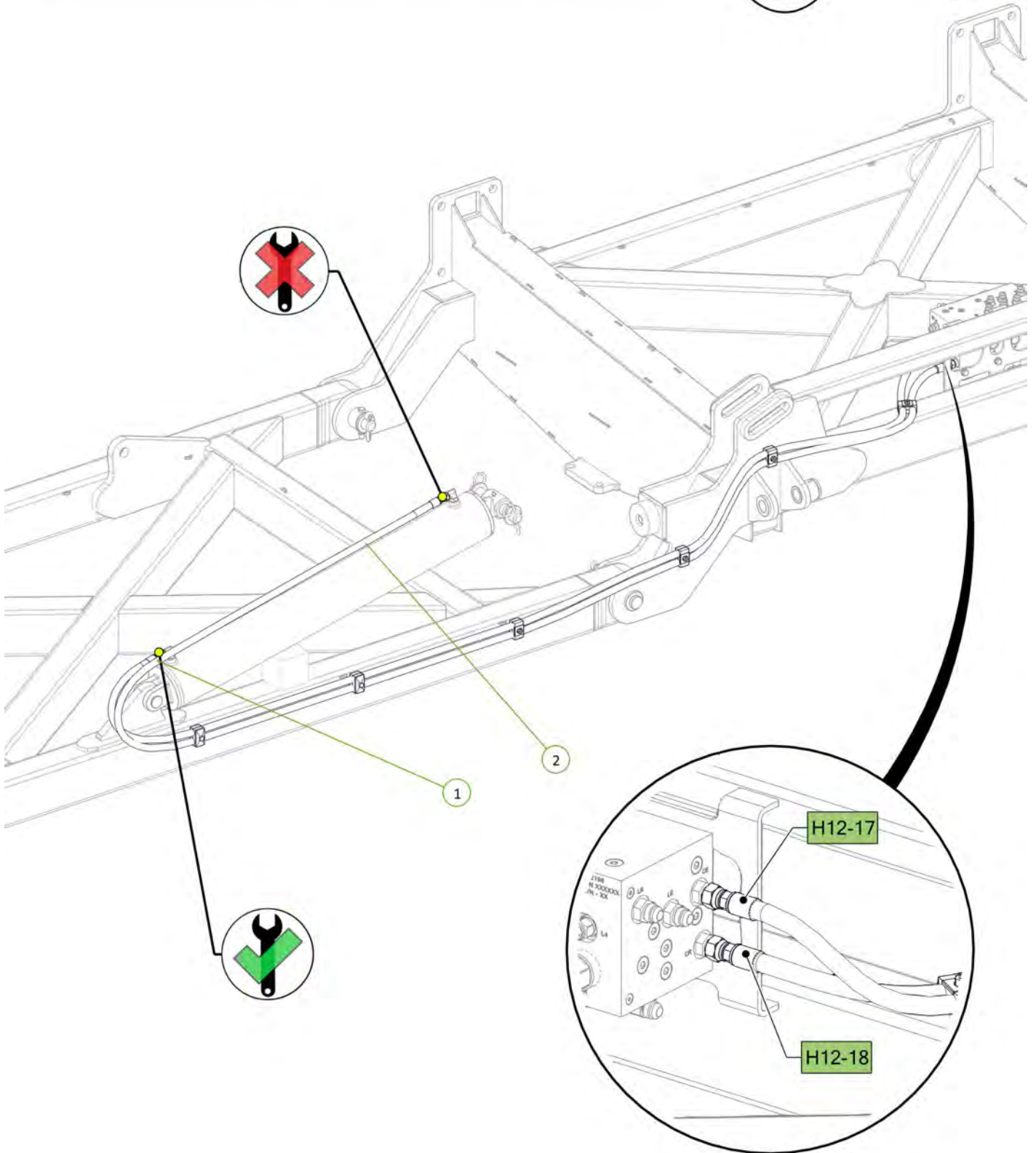

Item No.	Description	Qty	Number
1	5" Bore 36" Stroke 3 1/8" S/Tube 2" Rod Hydraulic Cylinder	1	0311-536ST

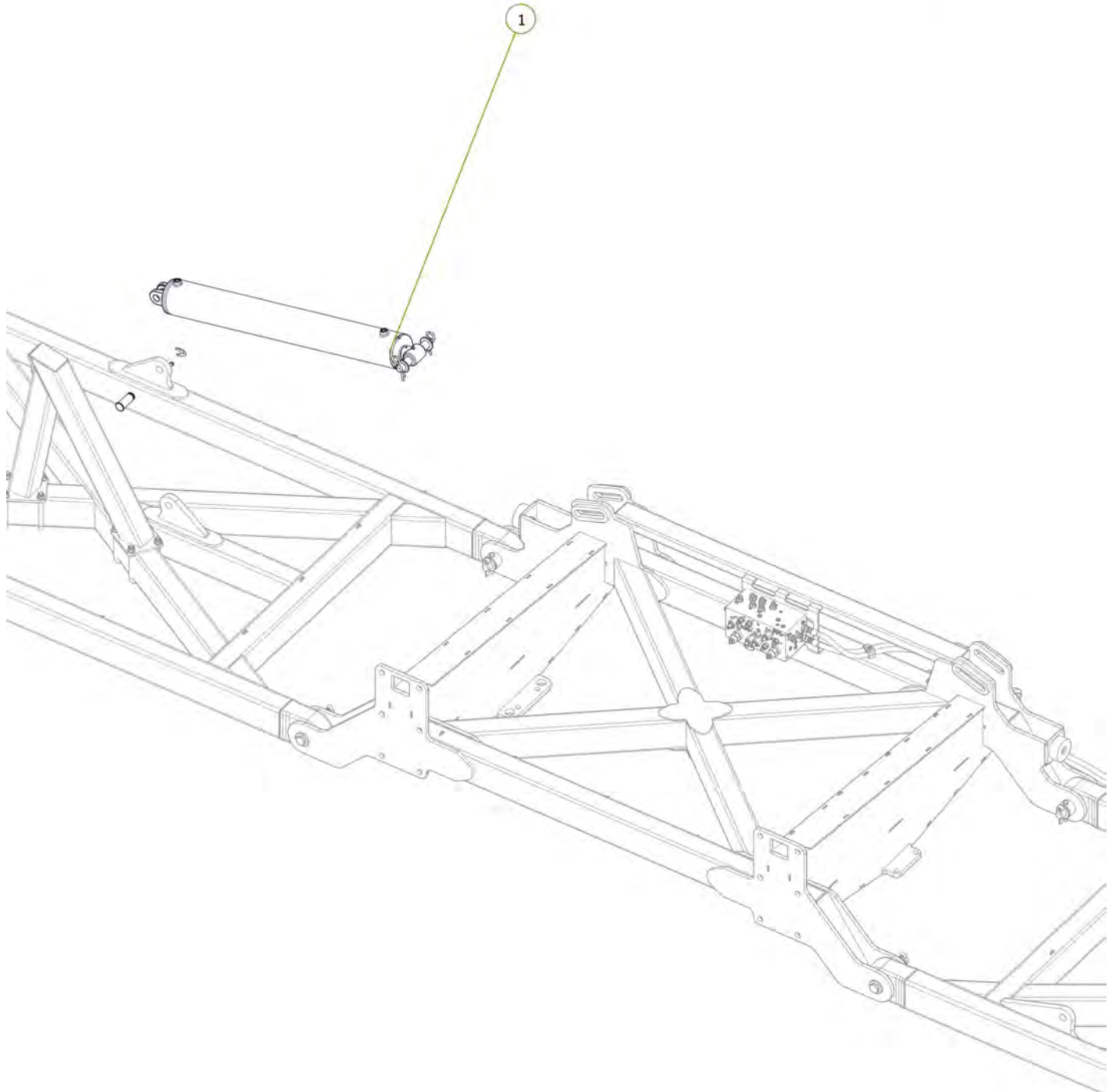

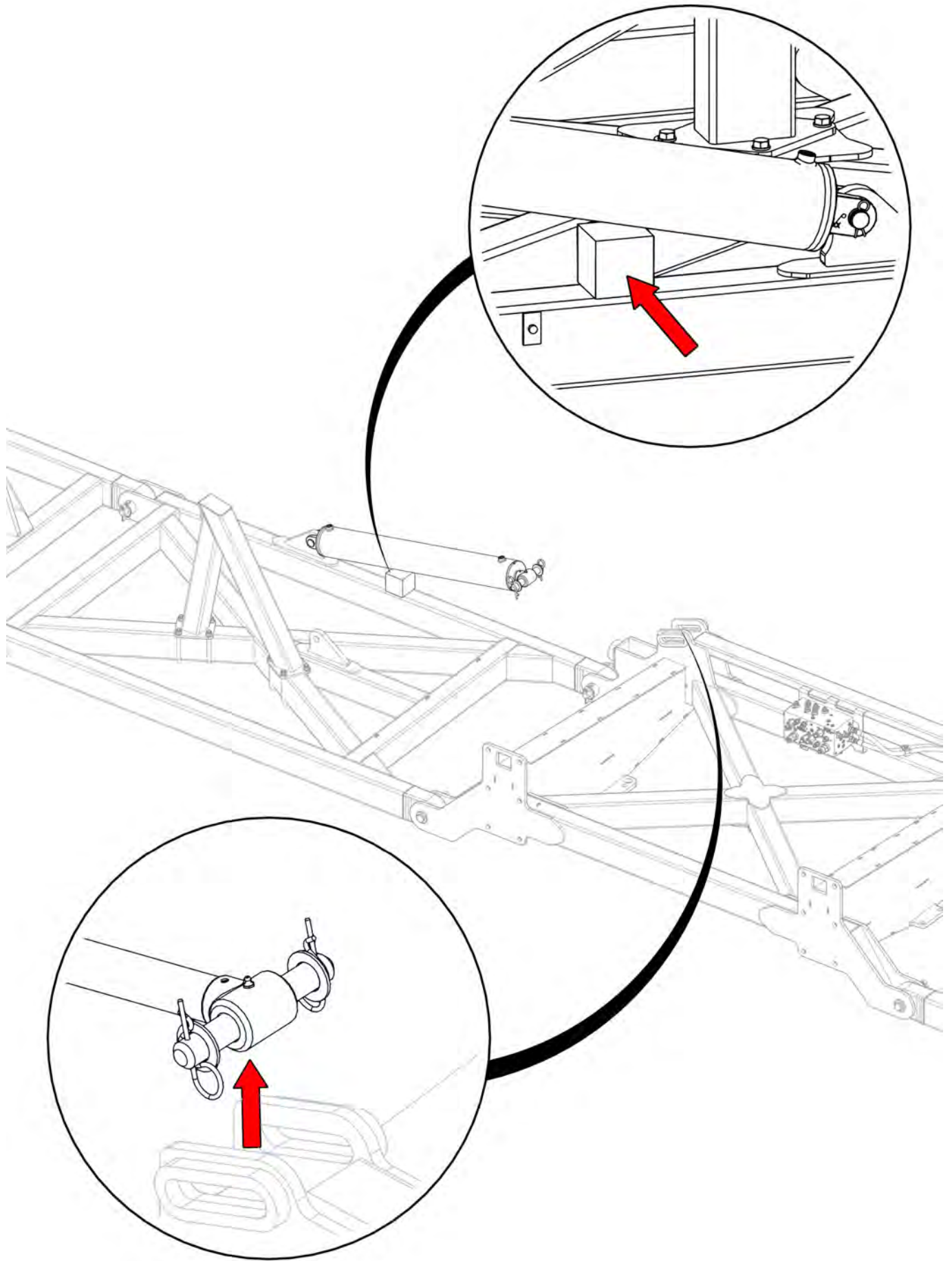

Item No.	Description	Qty	Number
1	3/4" JIC Male 3/4" UN O Ring Male 90° Elbow	2	0323-S91-1212

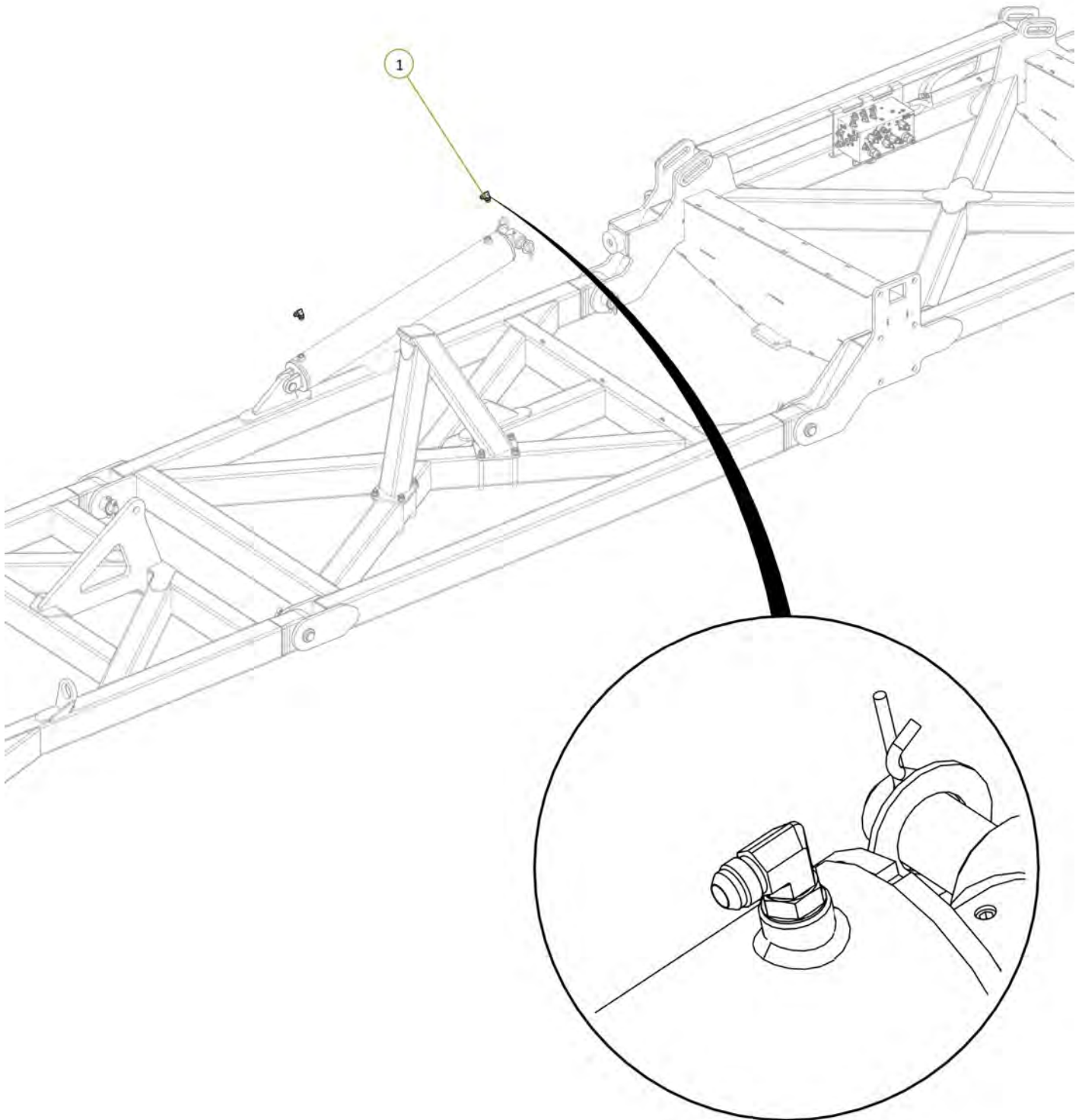

Item No.	Description	Qty	Number
1	Right CE Port to RH Main Wing Cylinder Extend Port	1	H12-21
2	Right CR Port to RH Main Wing Cylinder Retract Port	1	H12-22

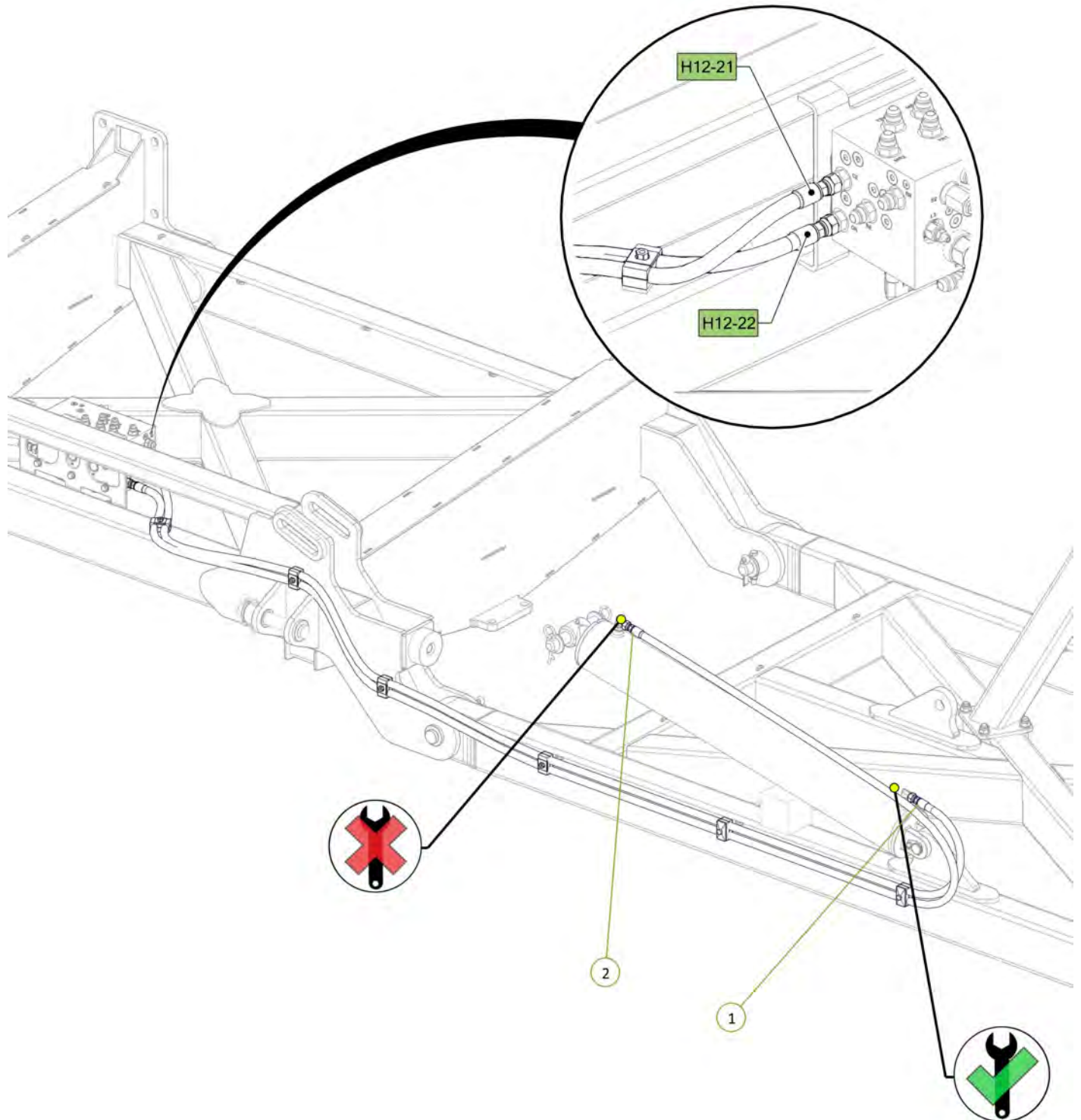

Item No.	Description	Qty	Number
1	4" Bore 30" Stroke 3" S/Tube 1.75" Rod Hydraulic Cylinder with Stop Tube & Clevis	1	0311-430ST-C2

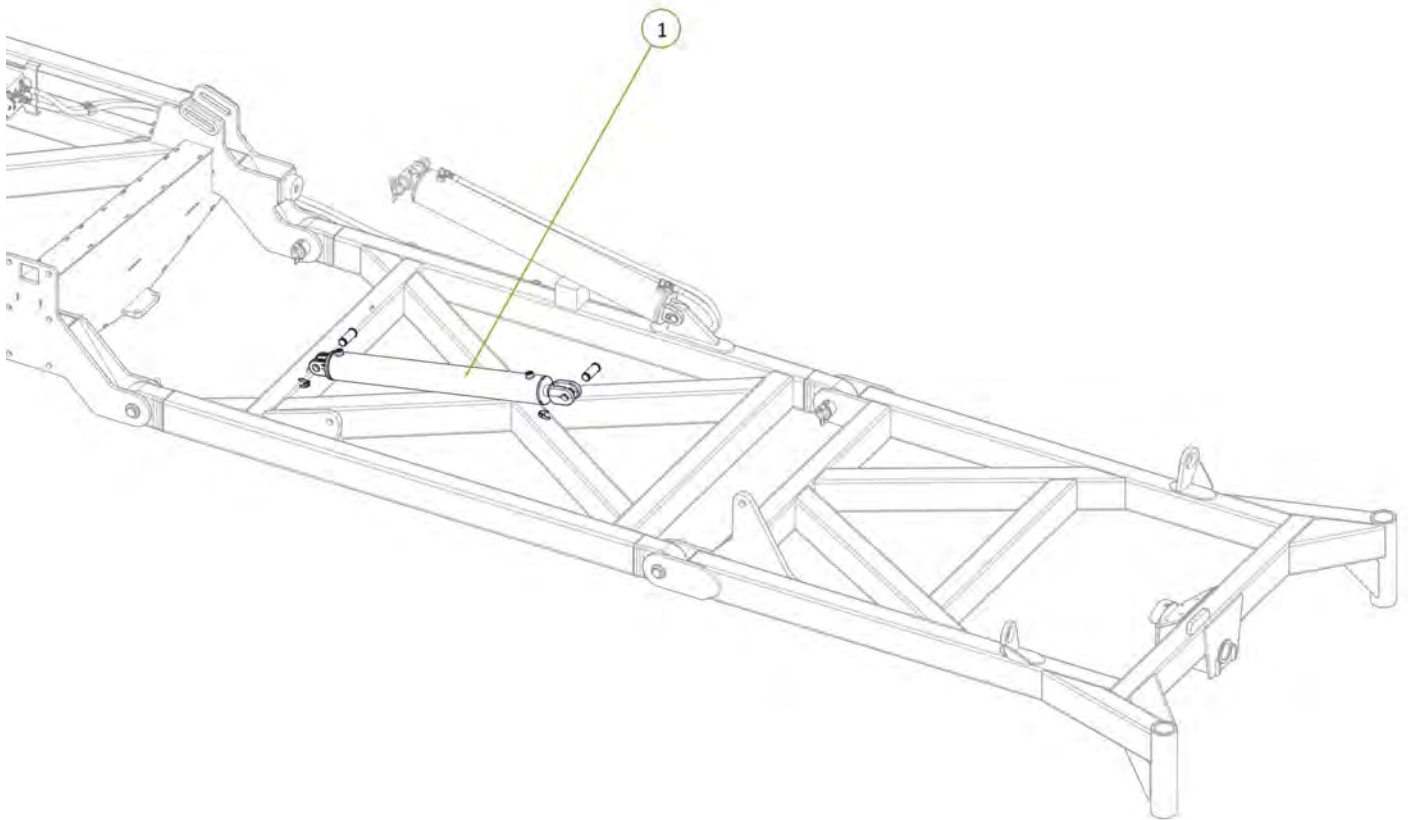

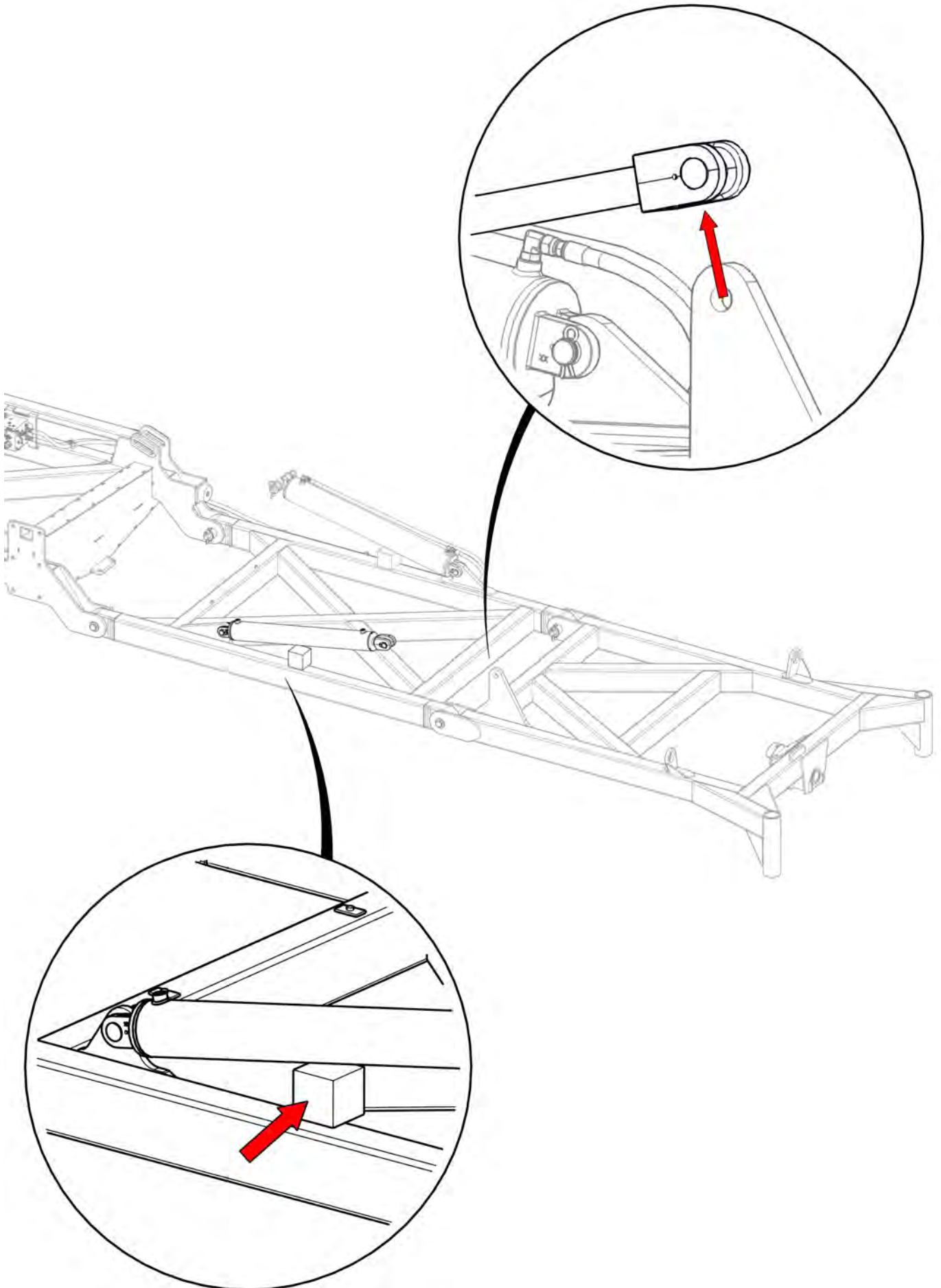

Item No.	Description	Qty	Number
1	3/4" JIC Male 3/4" UN O Ring Male 90° Elbow	2	0323-S91-1212

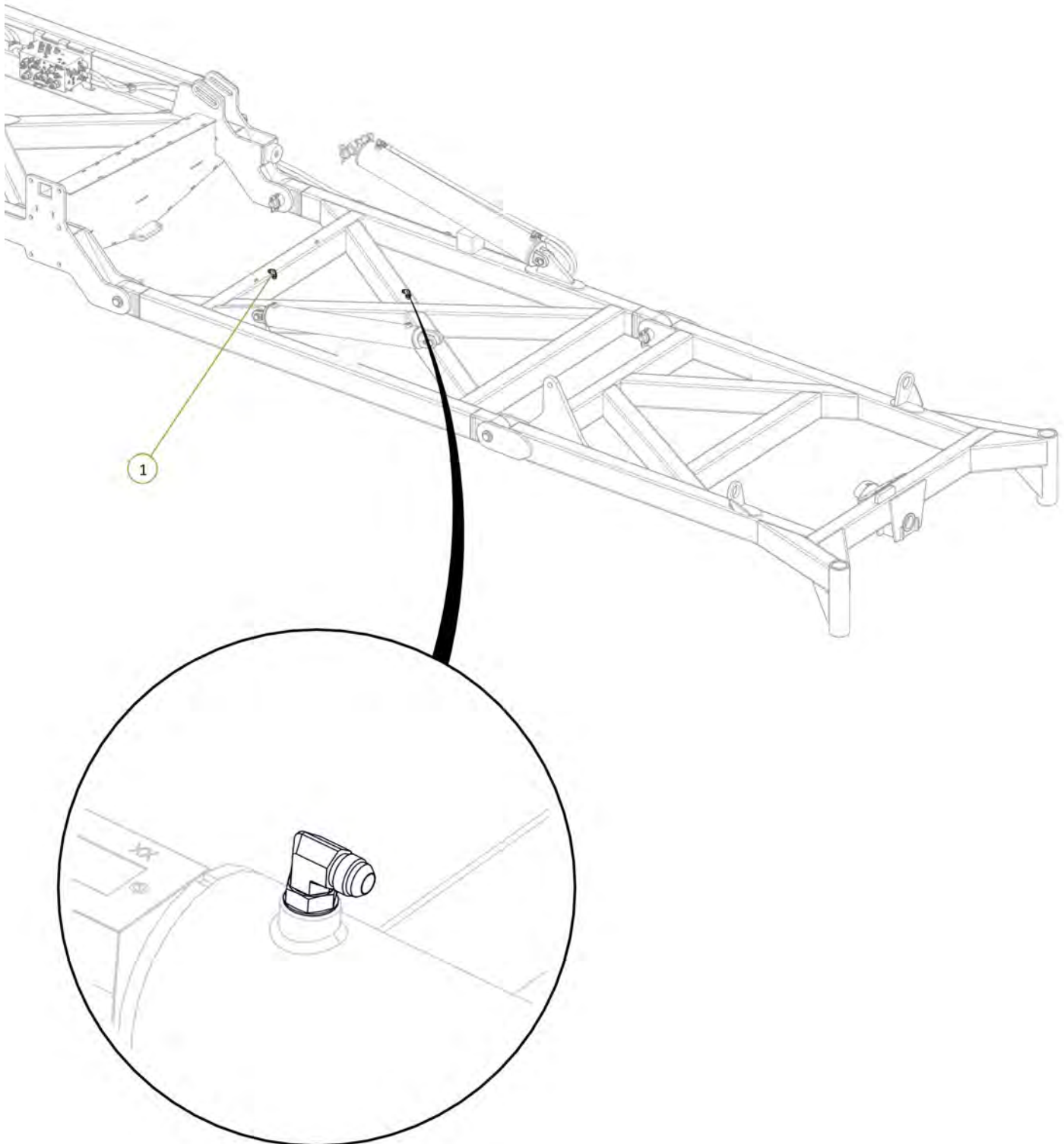

Item No.	Description	Qty	Number
1	LE Port to LH Outer Wing Cylinder Extend Port	1	H12-19
2	LR Port to LH Outer Wing Cylinder Retract Port	1	H12-20

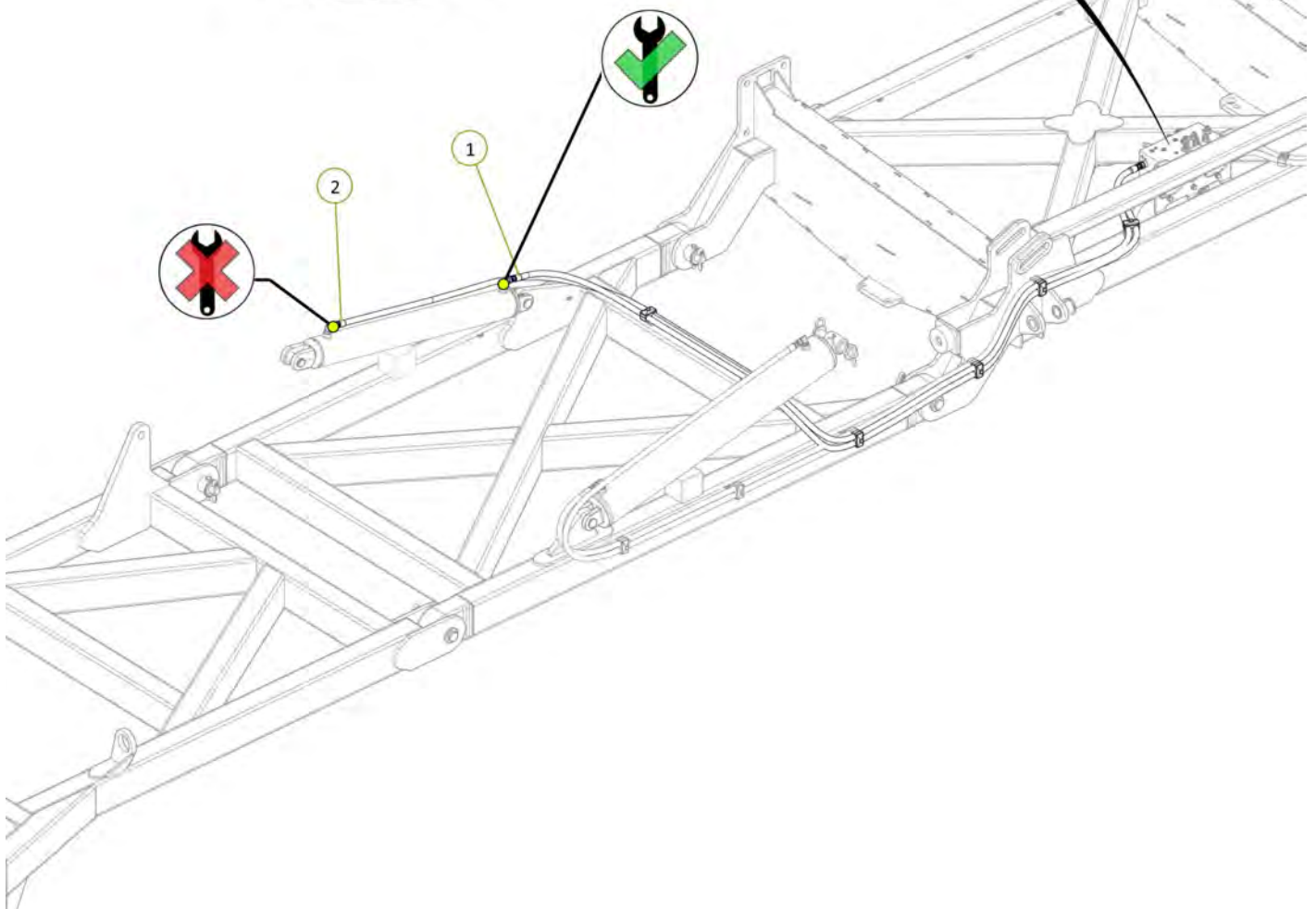
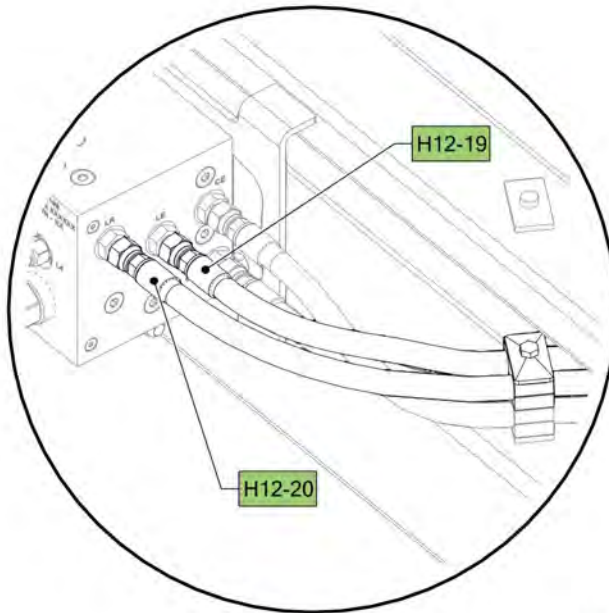

Item No.	Description	Qty	Number
1	4" Bore 30" Stroke 3" S/Tube 1.75" Rod Hydraulic Cylinder with Stop Tube & Clevis	1	0311-430ST-C2

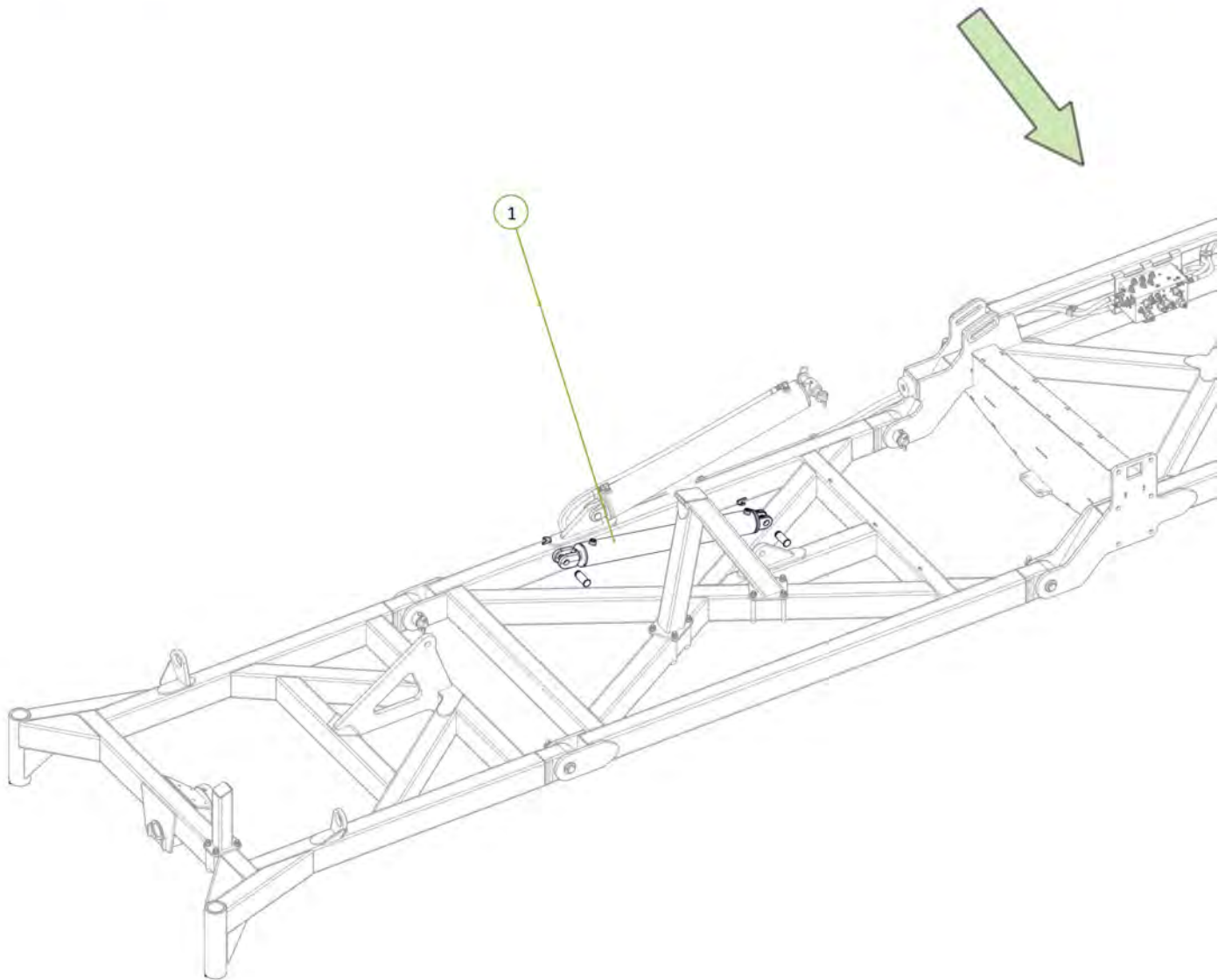

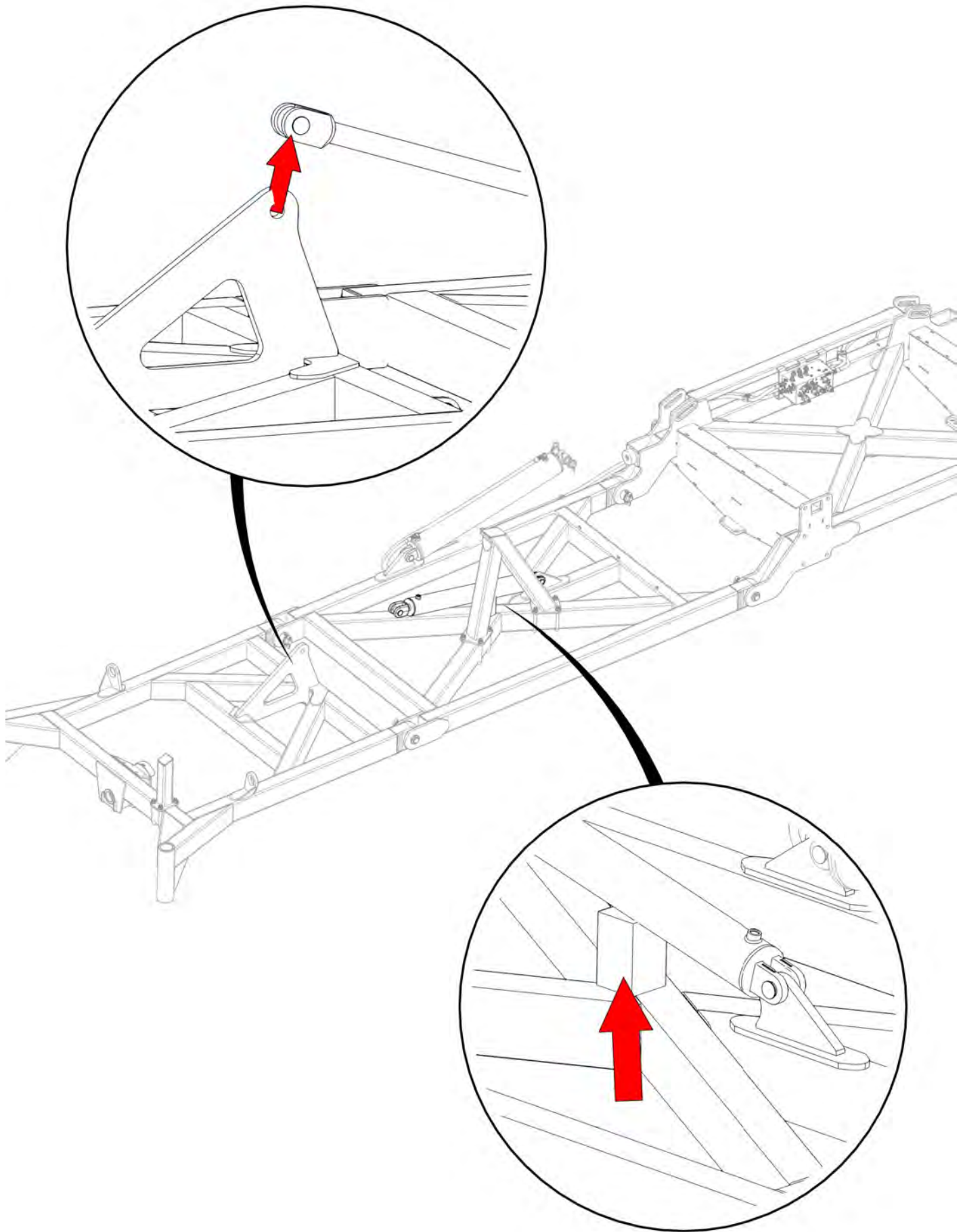

Item No.	Description	Qty	Number
1	3/4" JIC Male 3/4" UN O Ring Male 90° Elbow	2	0323-S91-1212

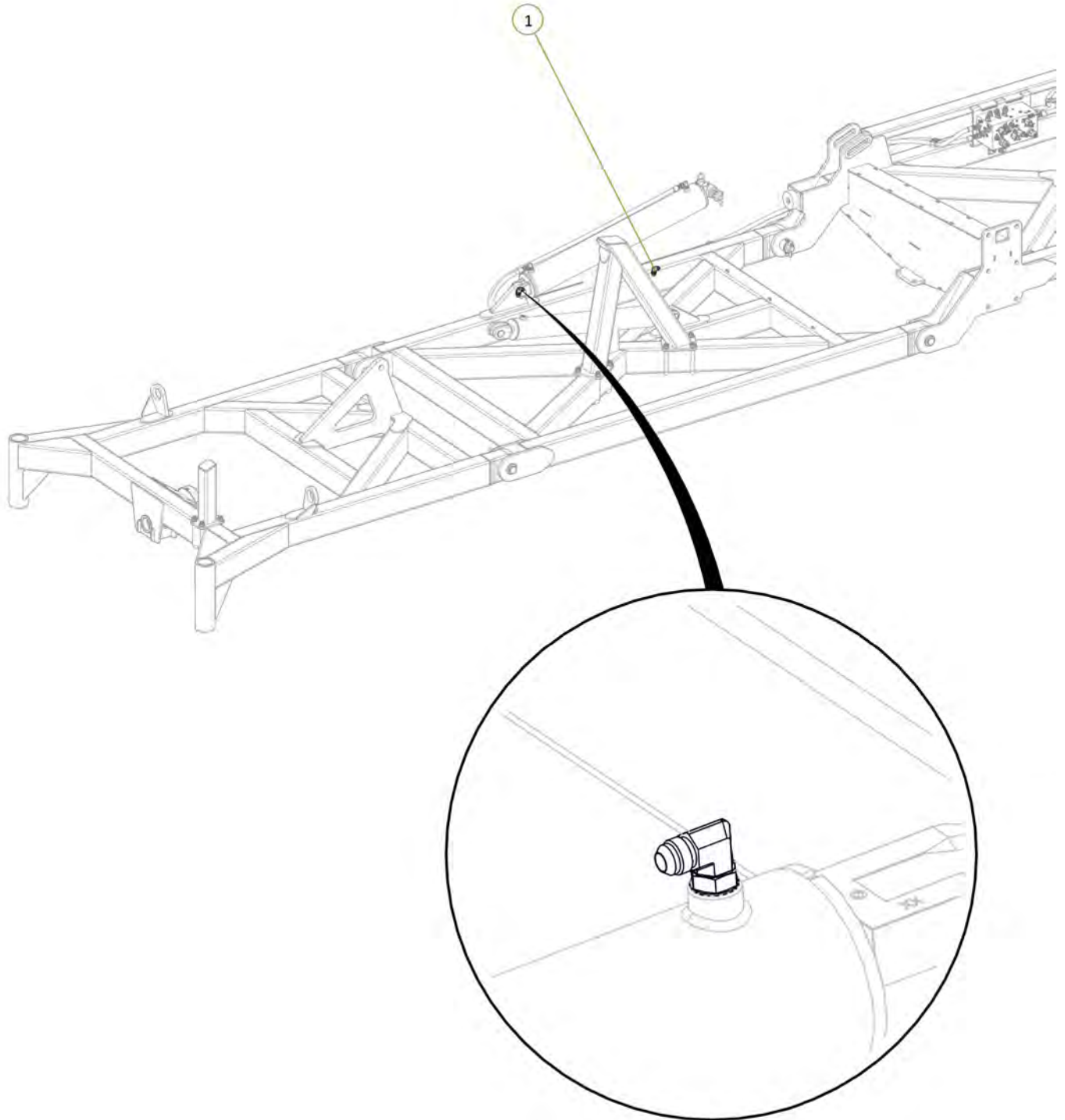

Item No.	Description	Qty	Number
1	RE Port to RH Outer Wing Cylinder Extend Port	1	H12-23
2	RR Port to RH Outer Wing Cylinder Retract Port	1	H12-24

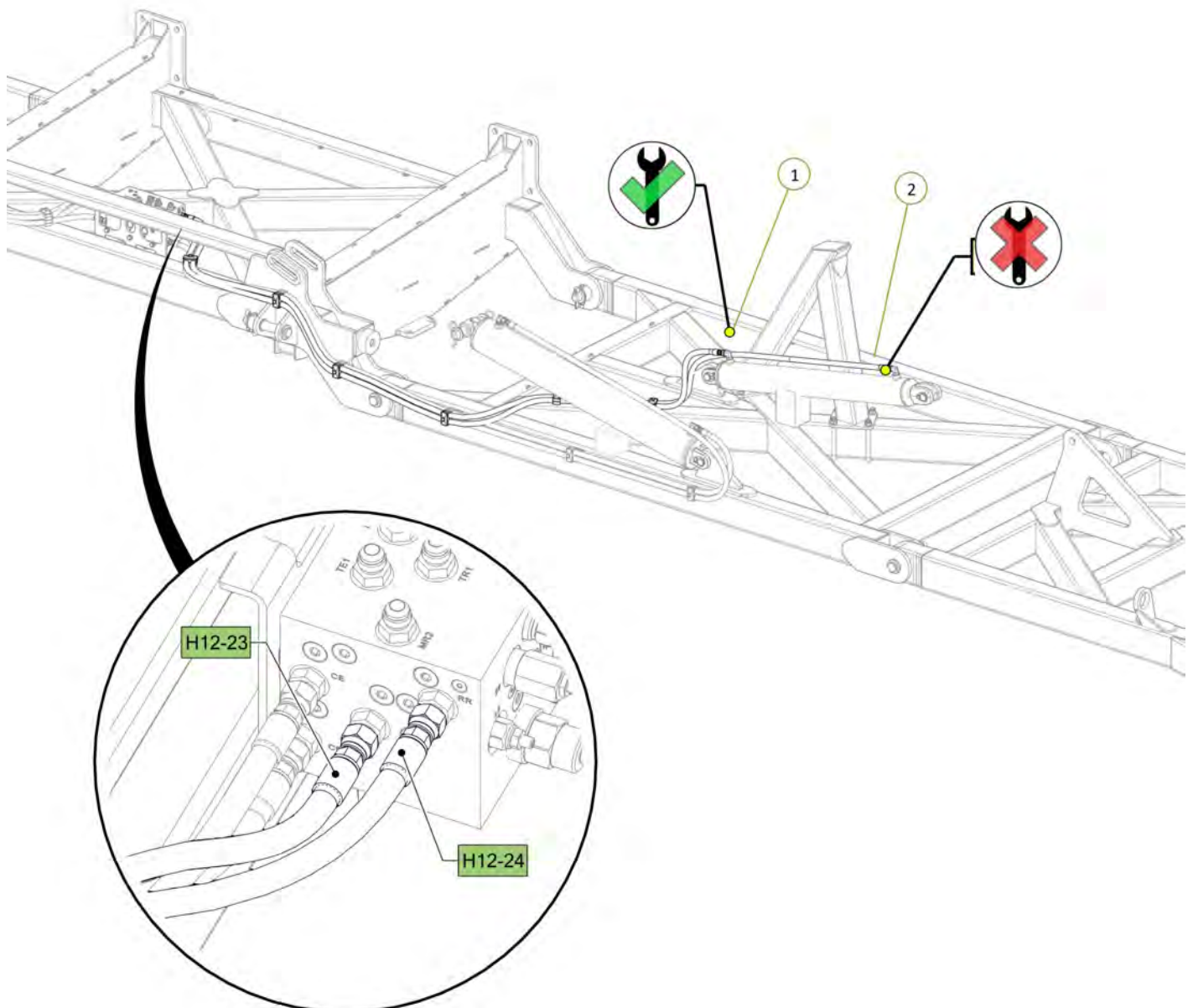
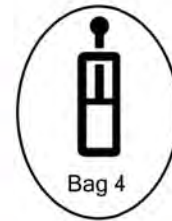

Item No.	Description	Qty	Number
1	Tractor to Sequence Valve EXT1 Port Fitted With Green EXT Decal	1	H12-01-GE-EXT1
2	Tractor to Sequence Valve RCT1 Port Fitted With Green RET Decal	1	H12-02-GR-RCT1

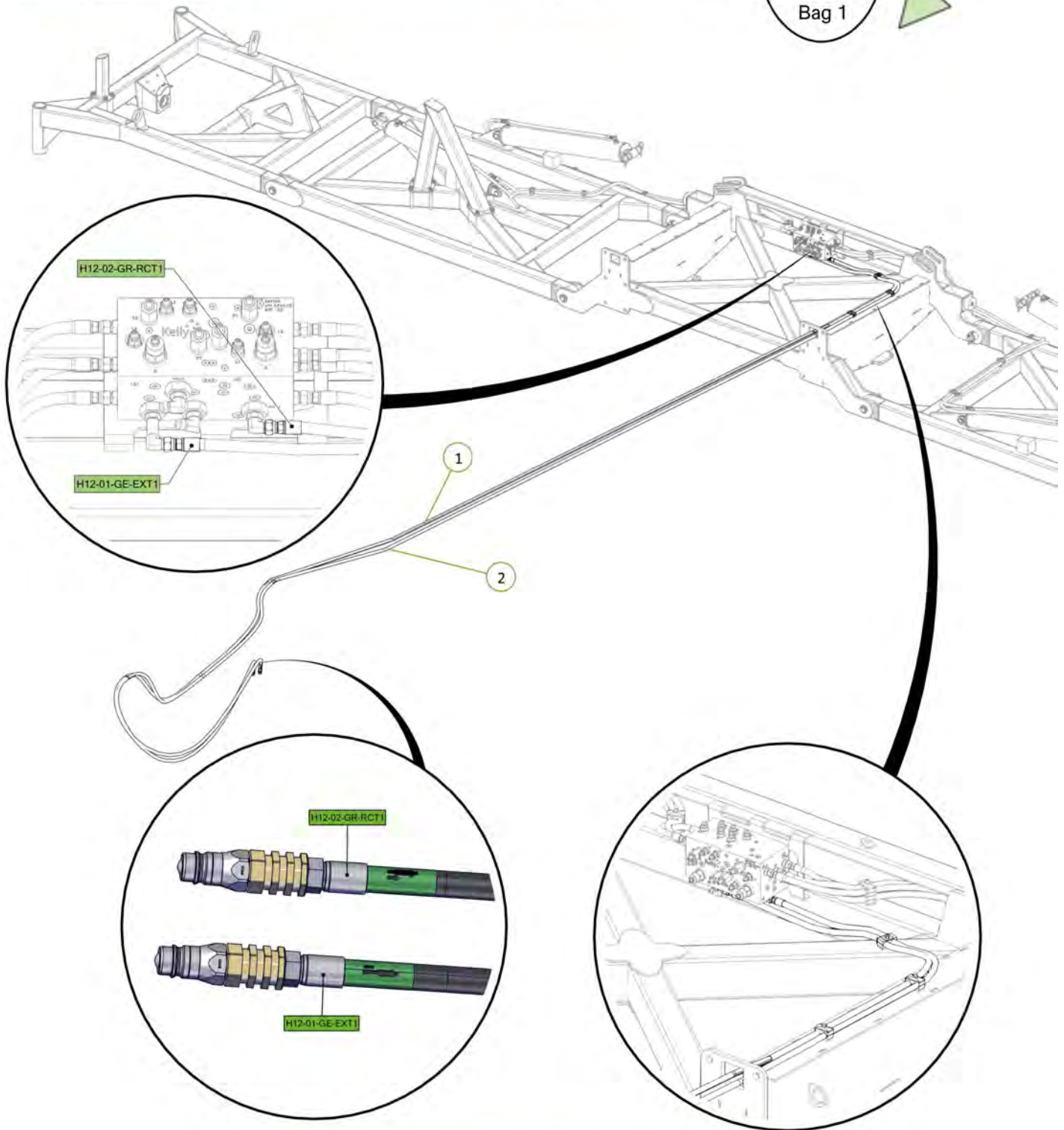

Ensure retract hose fittings are loose to allow air to escape

Check cylinders are chocked up to prevent clashing during extension

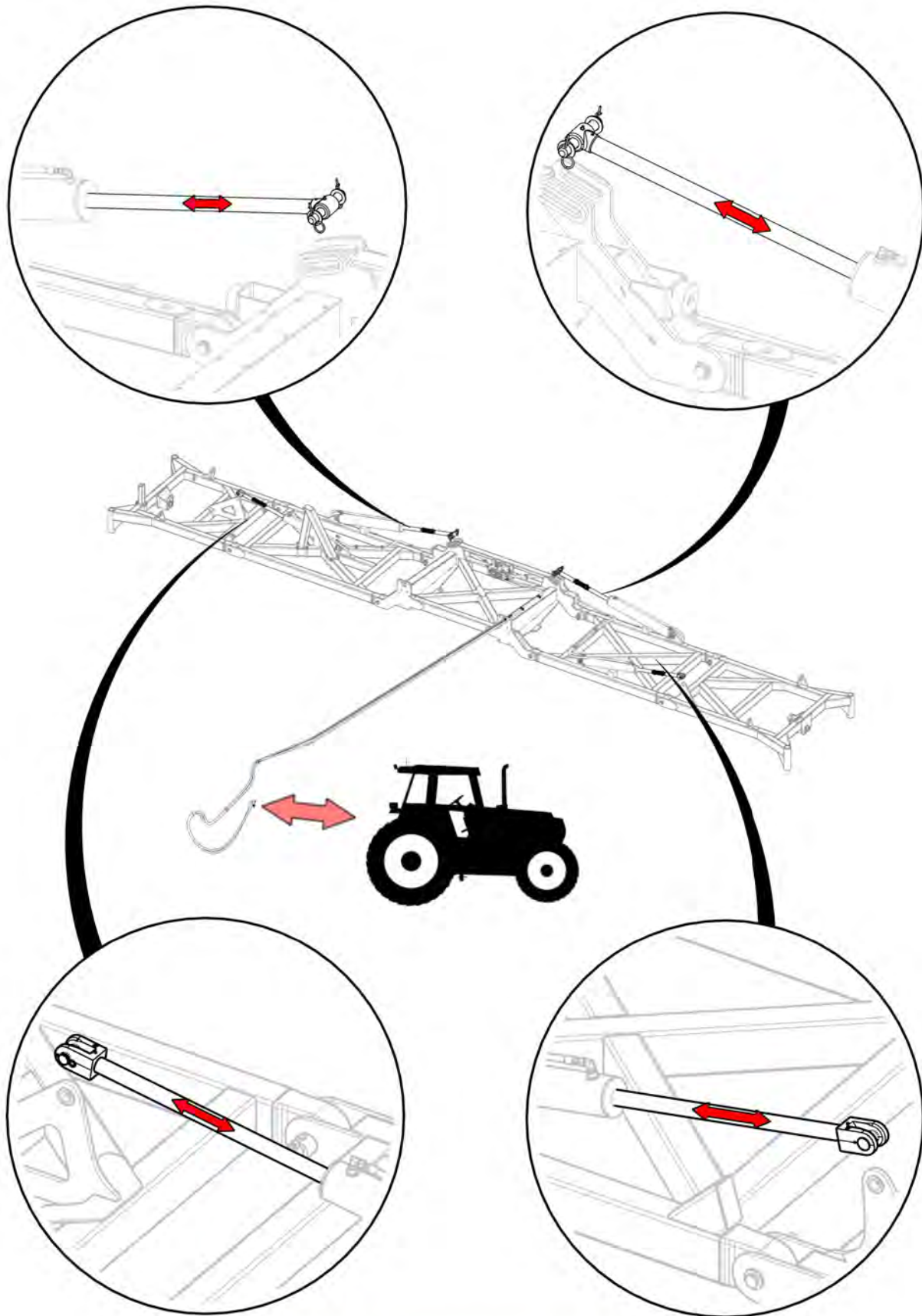

Cycle cylinders to expel air from system

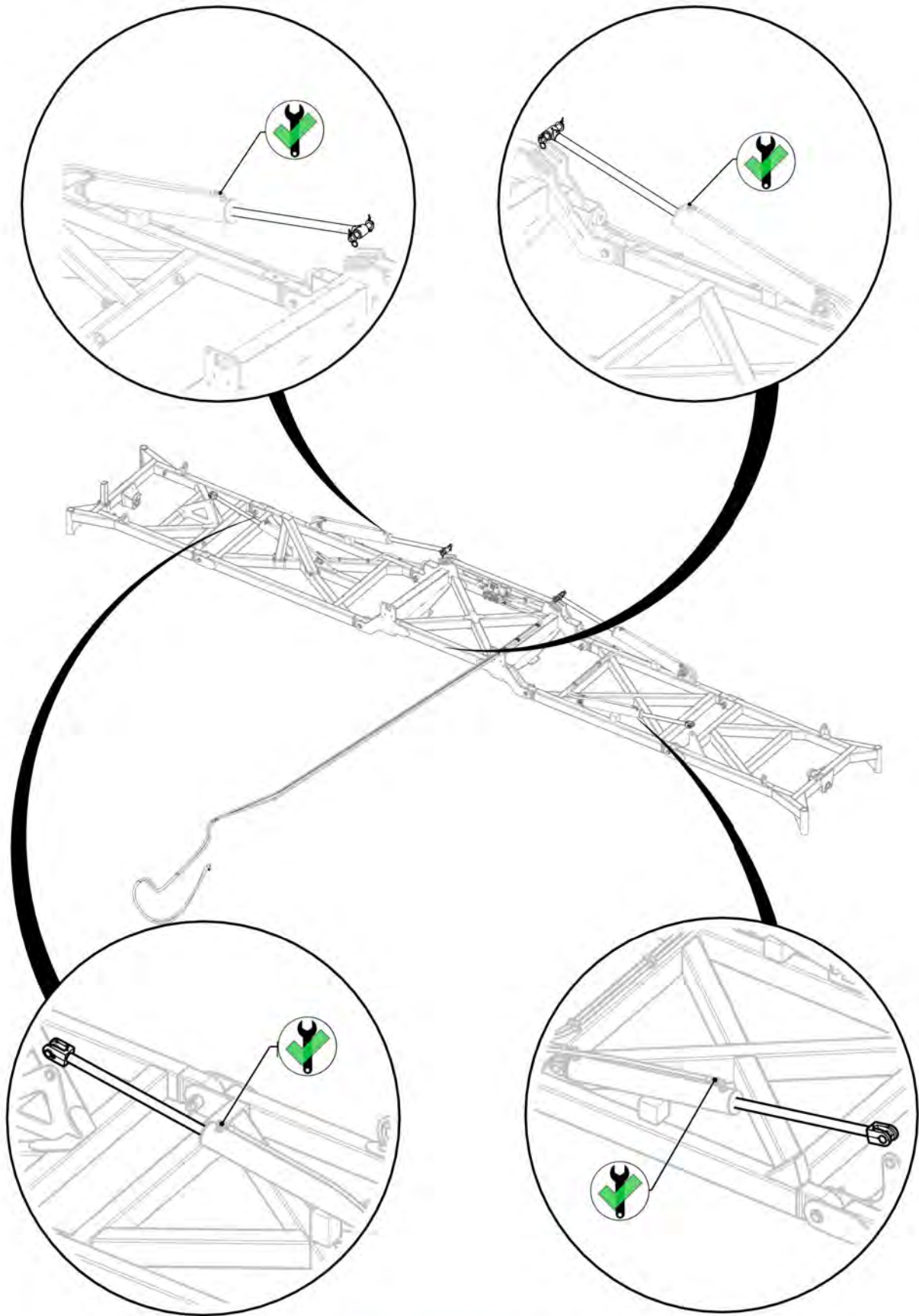

Tighten retract fittings

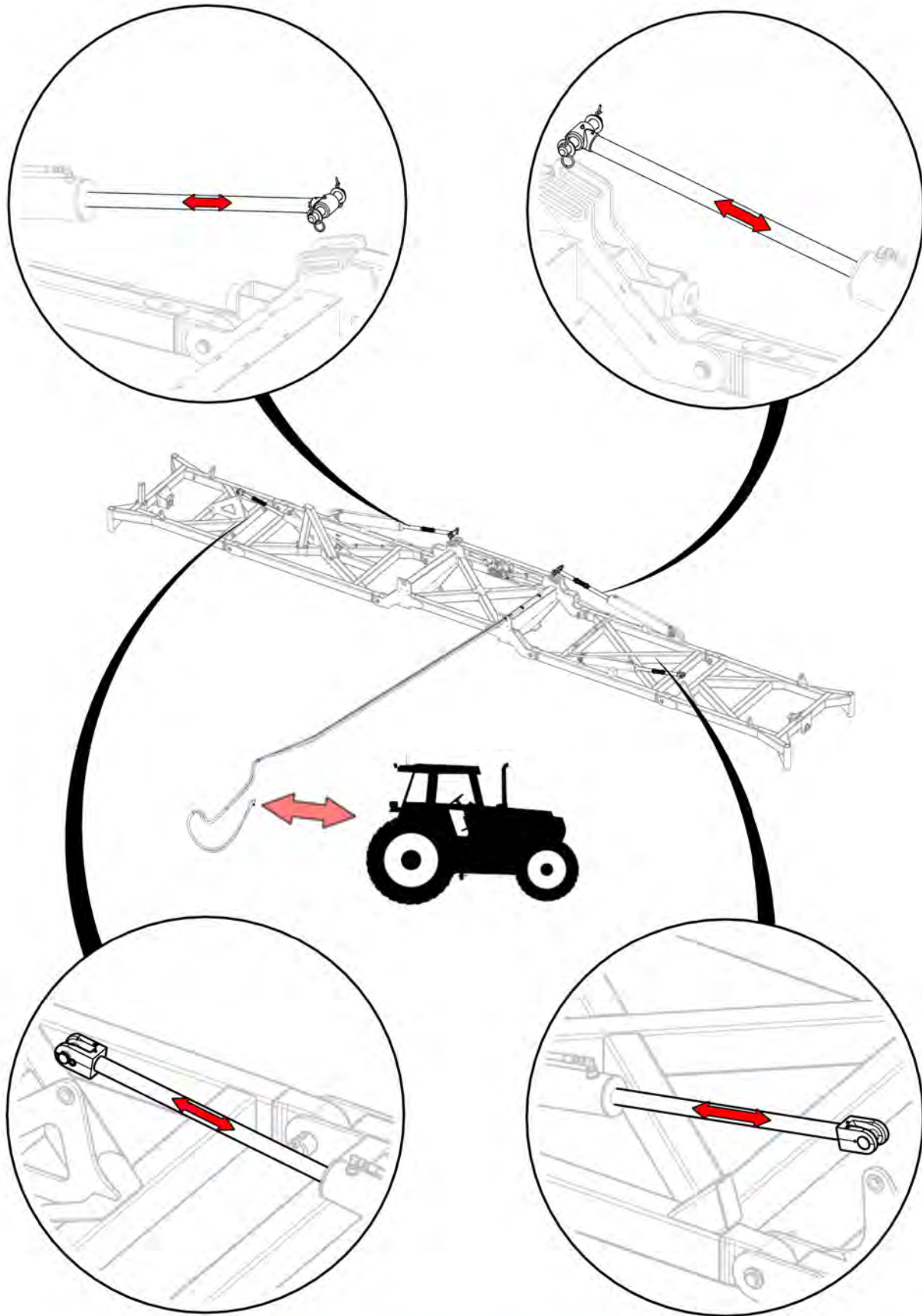

Cycle cylinders to expel air from system

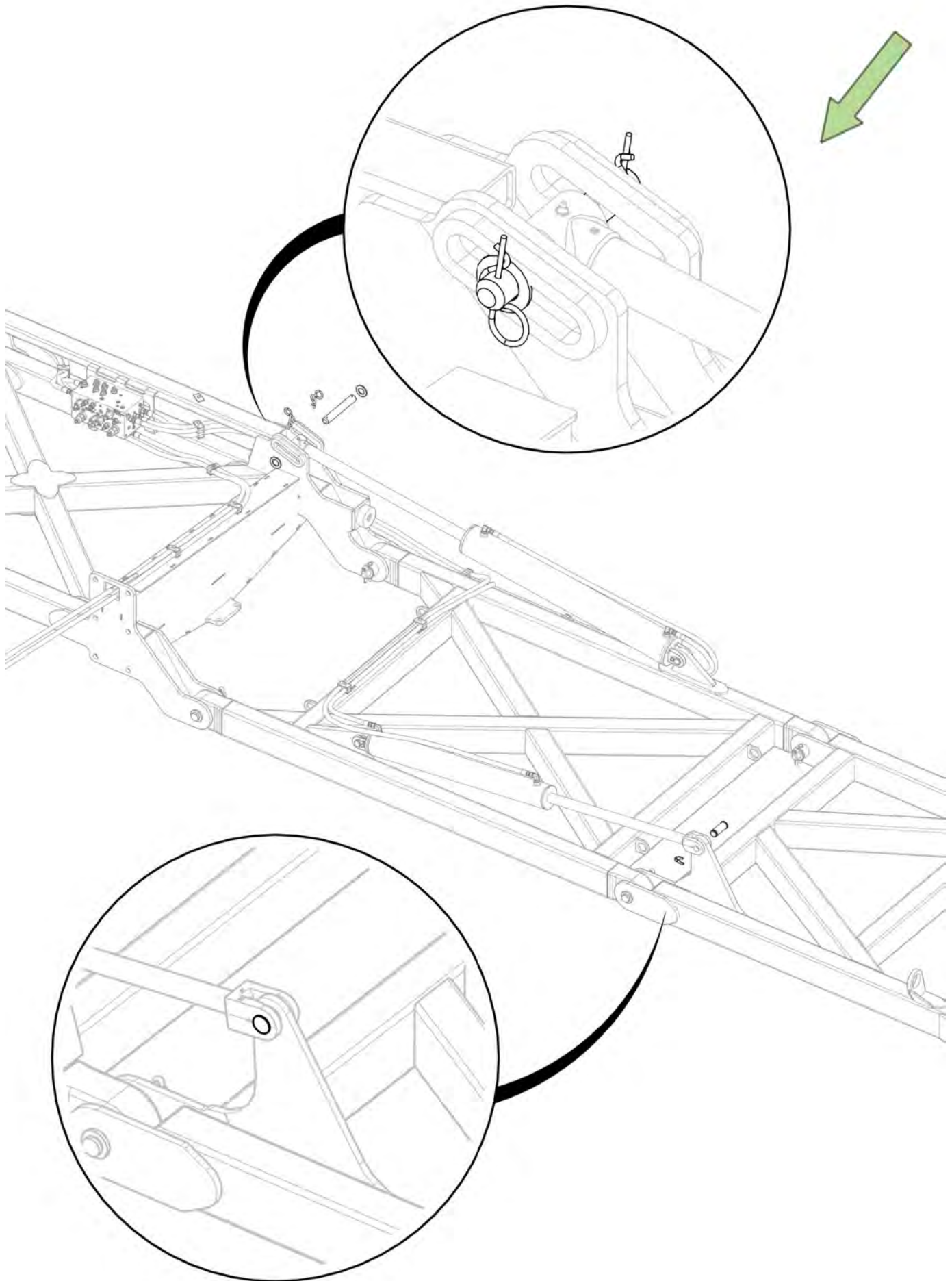

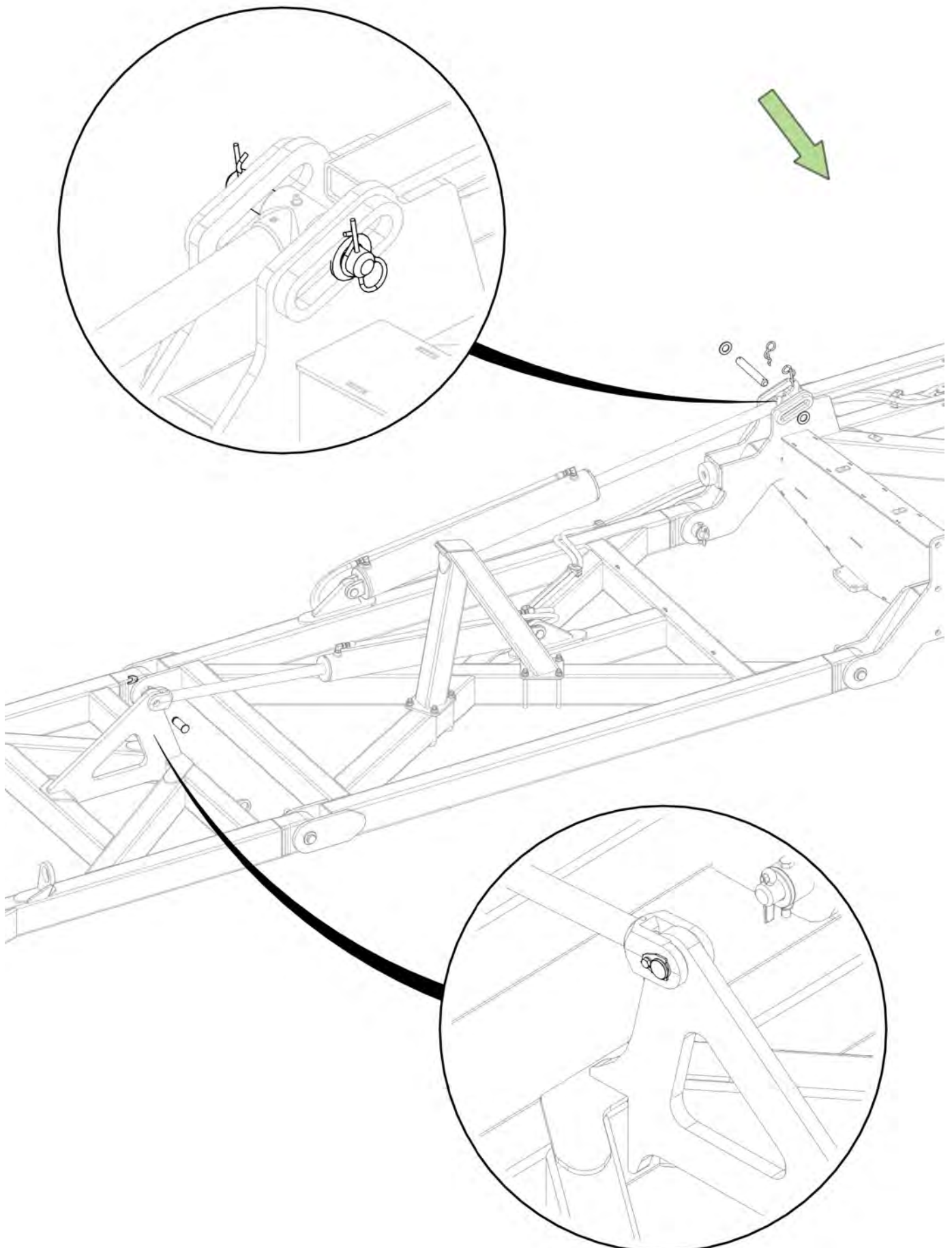

Item No.	Description	Qty	Number
1	Front A Frame	1	1540-02-2
2	M24 x 75 grade 8.8 zp Bolt	12	0211-2475
3	Nyloc Nut M24	12	0221-NYL24
4	Washer Flat M24	24	0231-F24

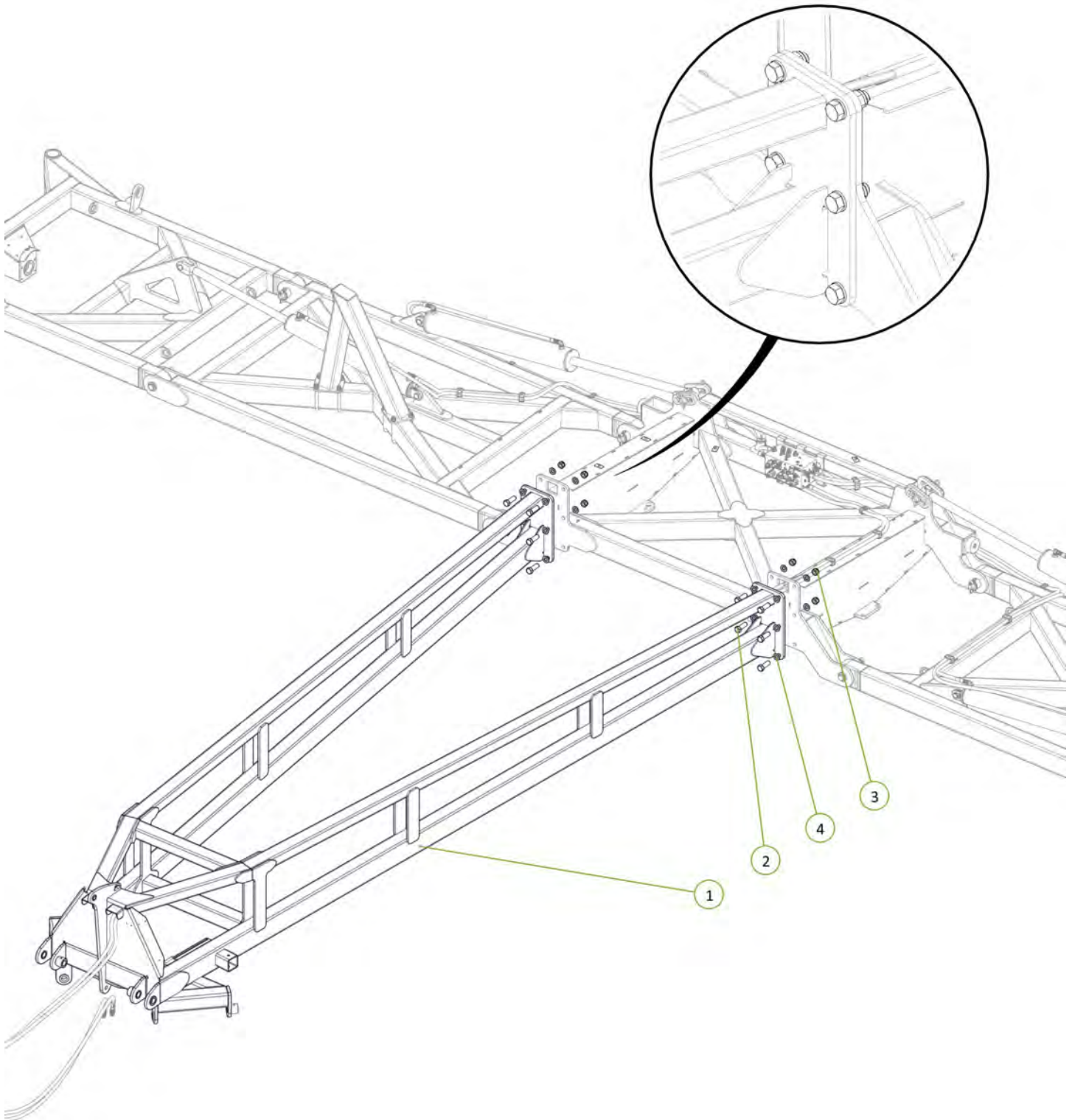
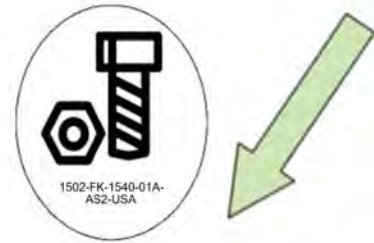

Item No.	Description	Qty	Number
1	2.75"R C/W 6 tonne 8 on 8" PCD Complete Assembly inc GS	1	0733-LG6080067
2	M20 x 170 grade 8.8 ZP Bolt	1	0211-20170
3	Nyloc Nut M20	1	0221-NYL20
4	Washer Flat M20	2	0231-F20

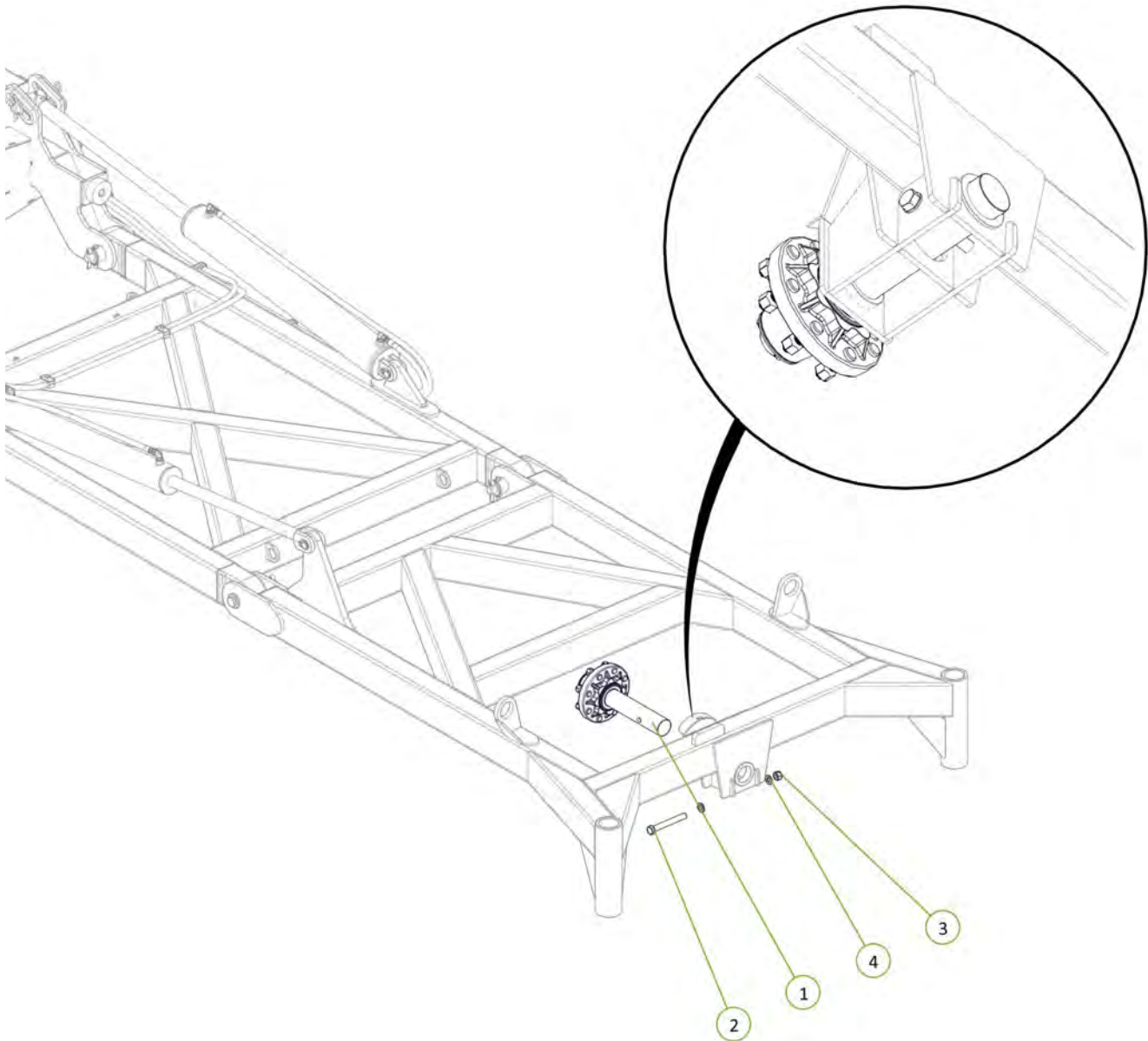

NOTE

The hub (0733-LG6080067) showed on item one is interchangeable. (Refer to page 5 for more information).

Item No.	Description	Qty	Number
1	2.75"R C/W 6 tonne 8 on 8" PCD Complete Assembly inc GS	1	0733-LG6080067
2	M20 x 170 grade 8.8 ZP Bolt	1	0211-20170
3	Nyloc Nut M20	1	0221-NYL20
4	Washer Flat M20	2	0231-F20

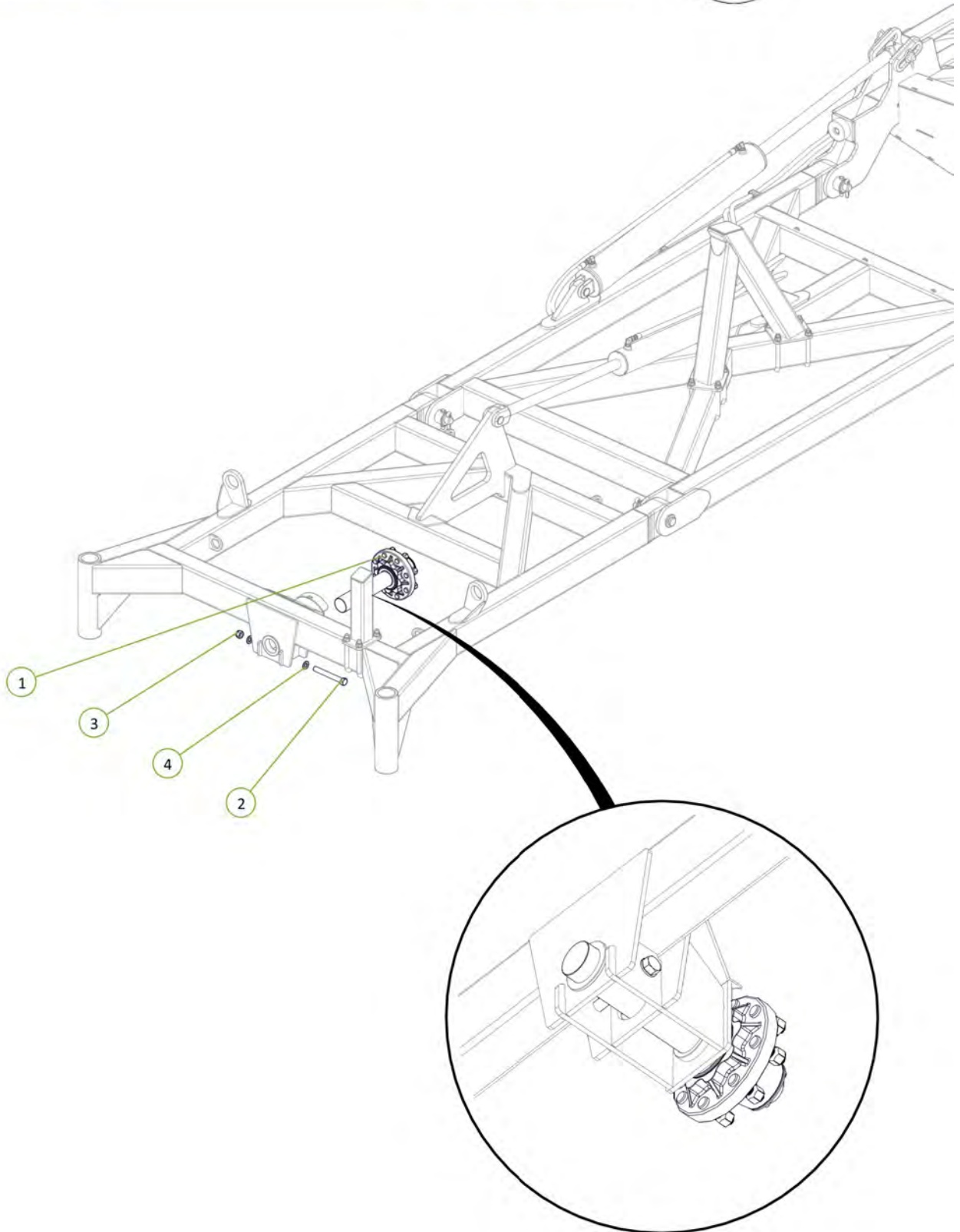

Item No.	Description	Qty	Number
1	12m Axle Beam	1	1540-11
2	M20 x 65 Grade 8.8 ZP Bolt	8	0211-2065
3	Nyloc Nut M20	8	0221-NYL20
4	Washer Flat M20	16	0231-F20

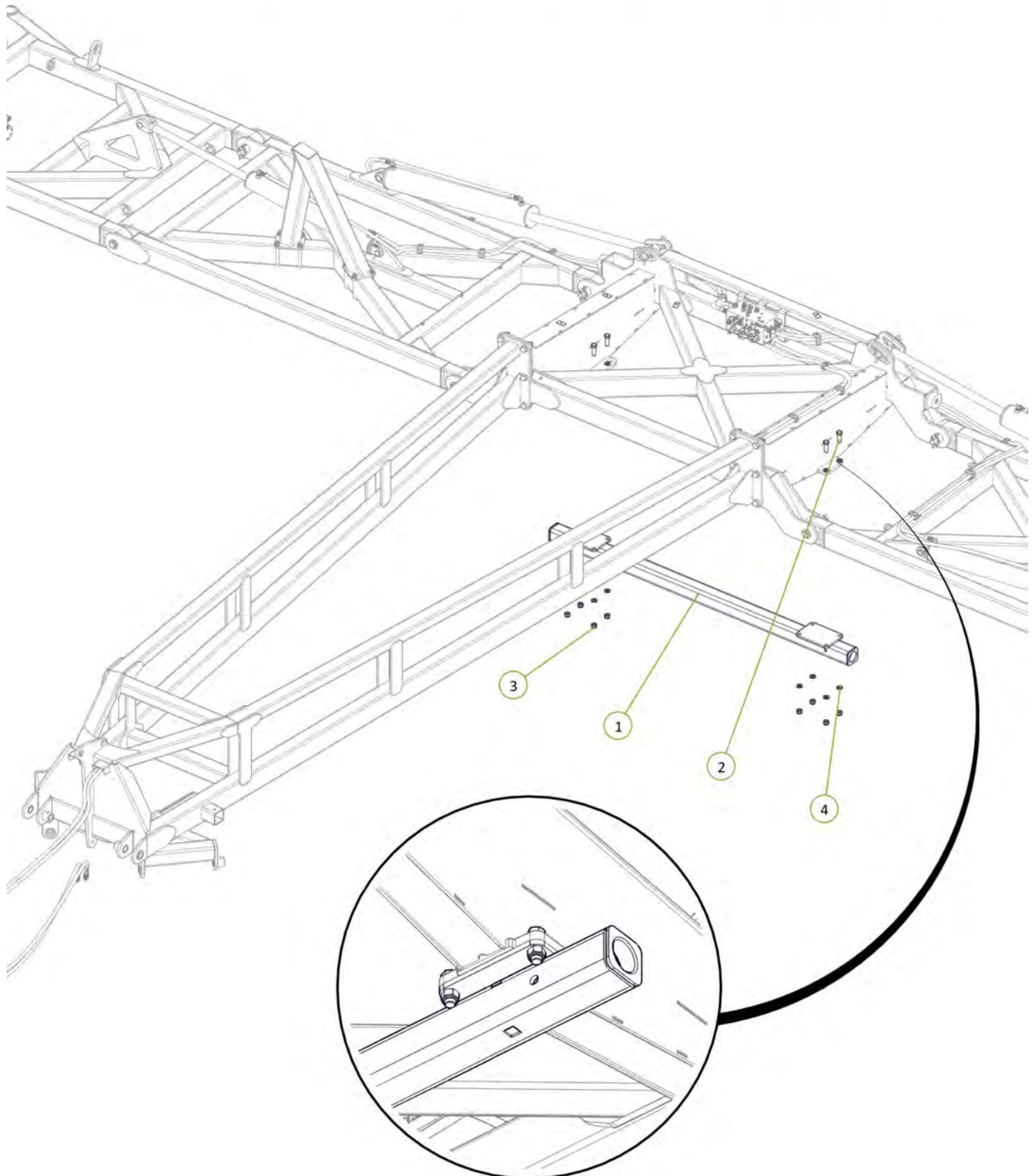

Item No.	Description	Qty	Number
1	2.75"R C/W 6 tonne 8 on 8" PCD Complete Assembly inc GS	2	0733-LG6080067
2	M20 x 140 grade 8.8 ZP Bolt	2	0211-20140
3	Nyloc Nut M20	2	0221-NYL20
4	Washer Flat M20	4	0231-F20

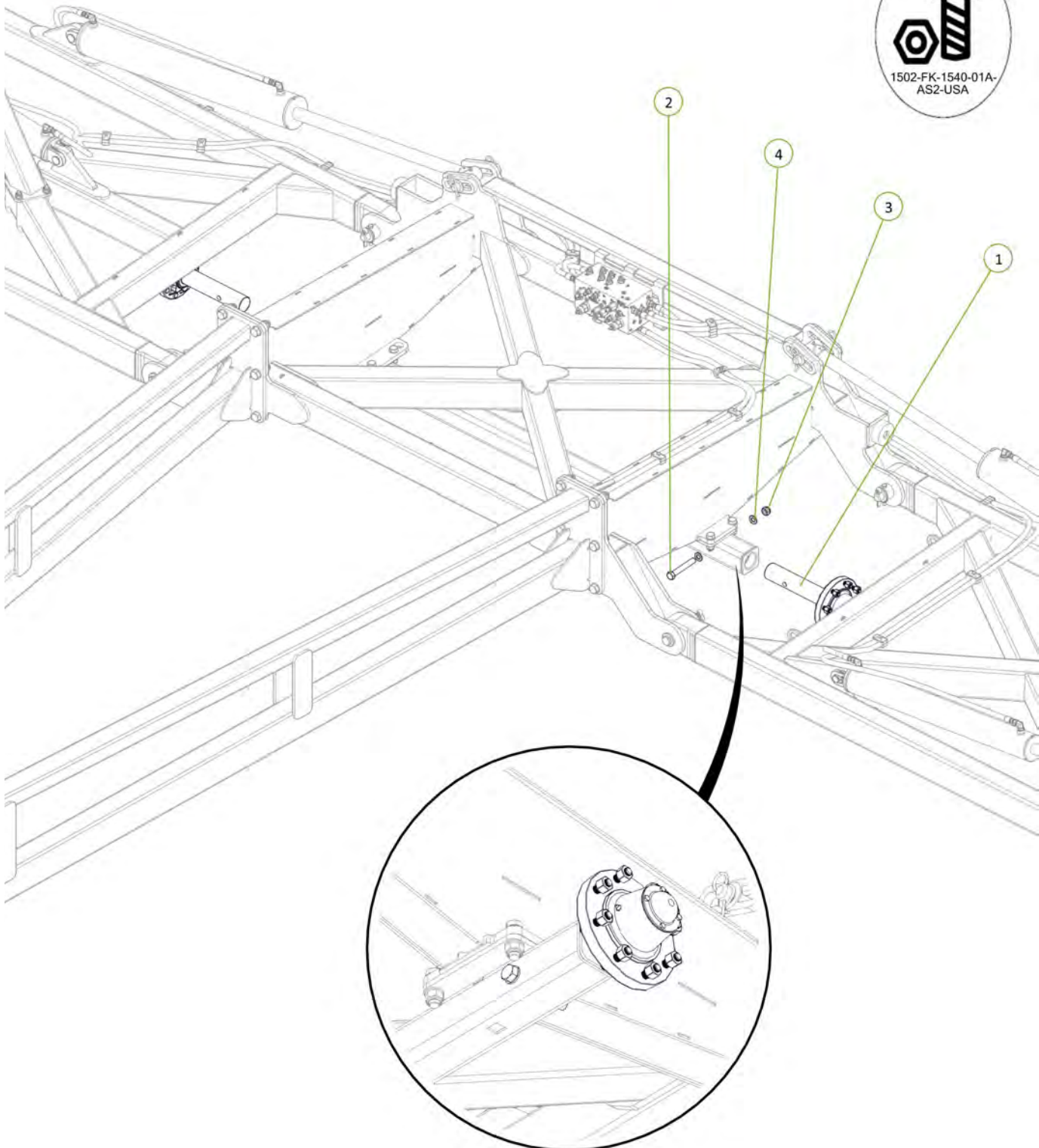

Item No.	Description	Qty	Number
1	400/55-22.5 Tyre on 8 on 8" PCD Rim (Right Hand)	2	0751-400-55-22.5TR-R
2	400/55-22.5 Tyre on 8 on 8" PCD Rim (Left Hand)	2	0751-400-55-22.5TR-L

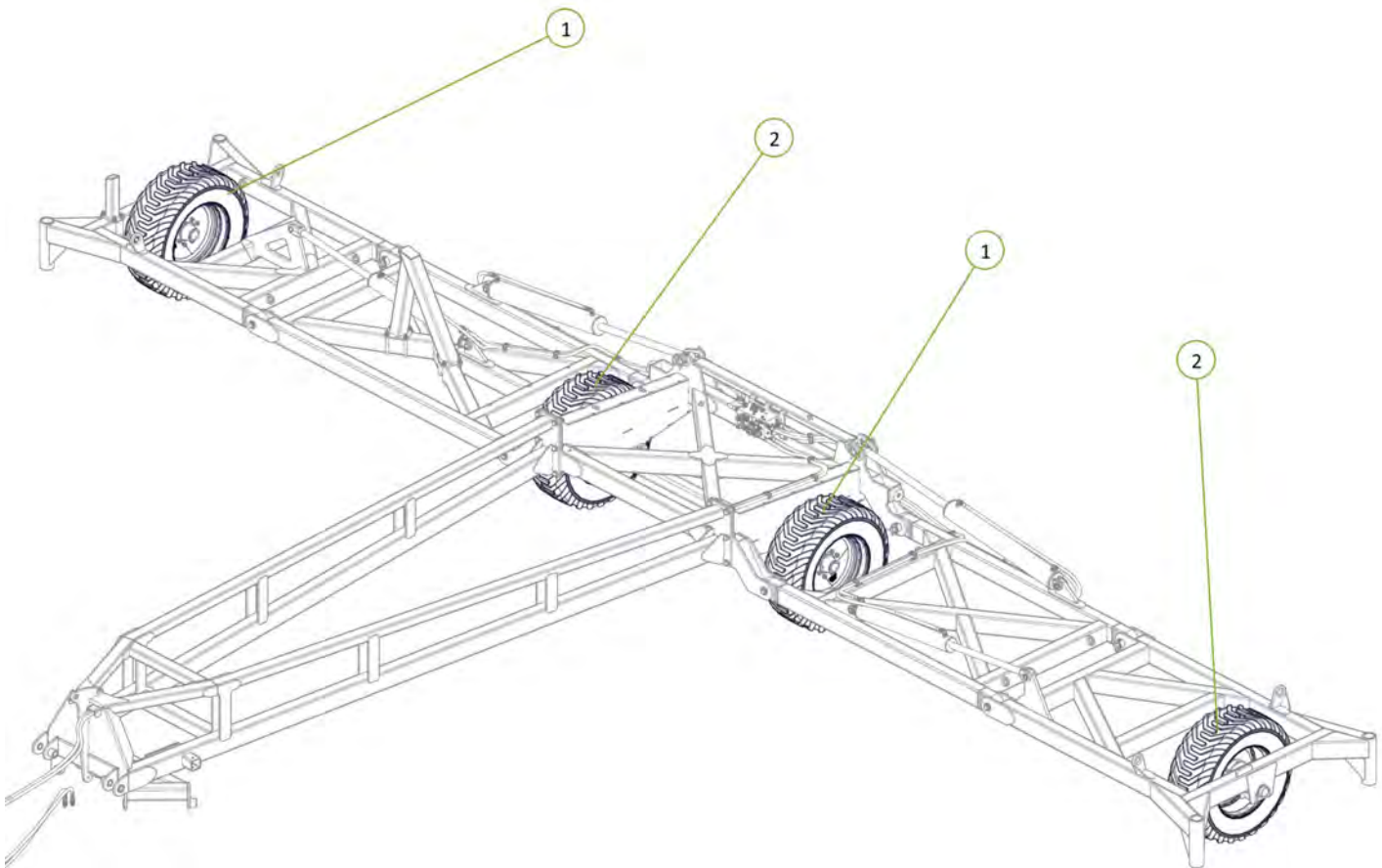

Torque wheel nuts to 100ft-lb / 140Nm

Item No.	Description	Qty	Number
1	Tapered T-Bar Drawbar	1	1510-08-2
2	Walking Axle Linkage Pivot Pin	2	1601-P38-220
3	Drawbar Pivot Bush	4	0801-B423838
4	M12 x 90 Class 8.8 ZP Bolt	2	0211-1290
5	Nyloc Nut M12	2	0221-NYL12
6	Cotter Pin M13 x 63	2	0261-PINC1363

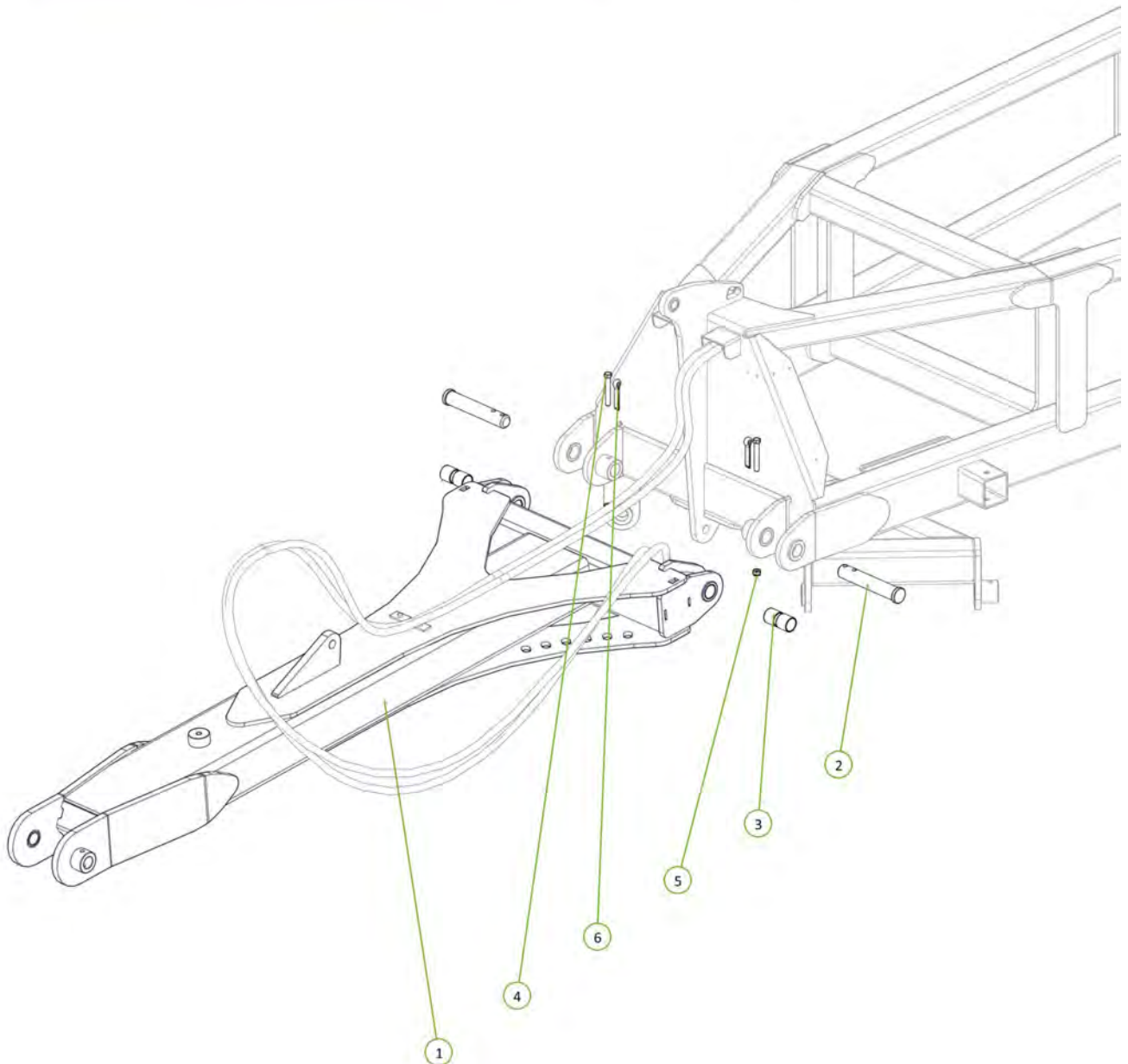

Item No.	Description	Qty	Number
1	Tow Hitch For Bull Pull Swivel Hitch	1	0810-09-BP
2	M12 x 90 Class 8.8 ZP Bolt	2	0211-1290
3	Tow Hitch Pivot Pin	1	0801-10-14
4	Nyloc Nut M12	2	0221-NYL12
5	Bull Pull Swivel Hitch CAT 4 wt 1-1/2' Insert	1	0801-BPF-CAT-4JDF-2
6	1" UNF Grade 8 ZP Bolt x 5-1/2"	3	0213-1-512
7	Nyloc Nut 1" UNF	3	0223-NYL1
8	35 ID x 50mm DX Bush	2	0113-MB3550DX
9	Grease Nipple 1/4" UNF 45°	2	0181-GN1/445

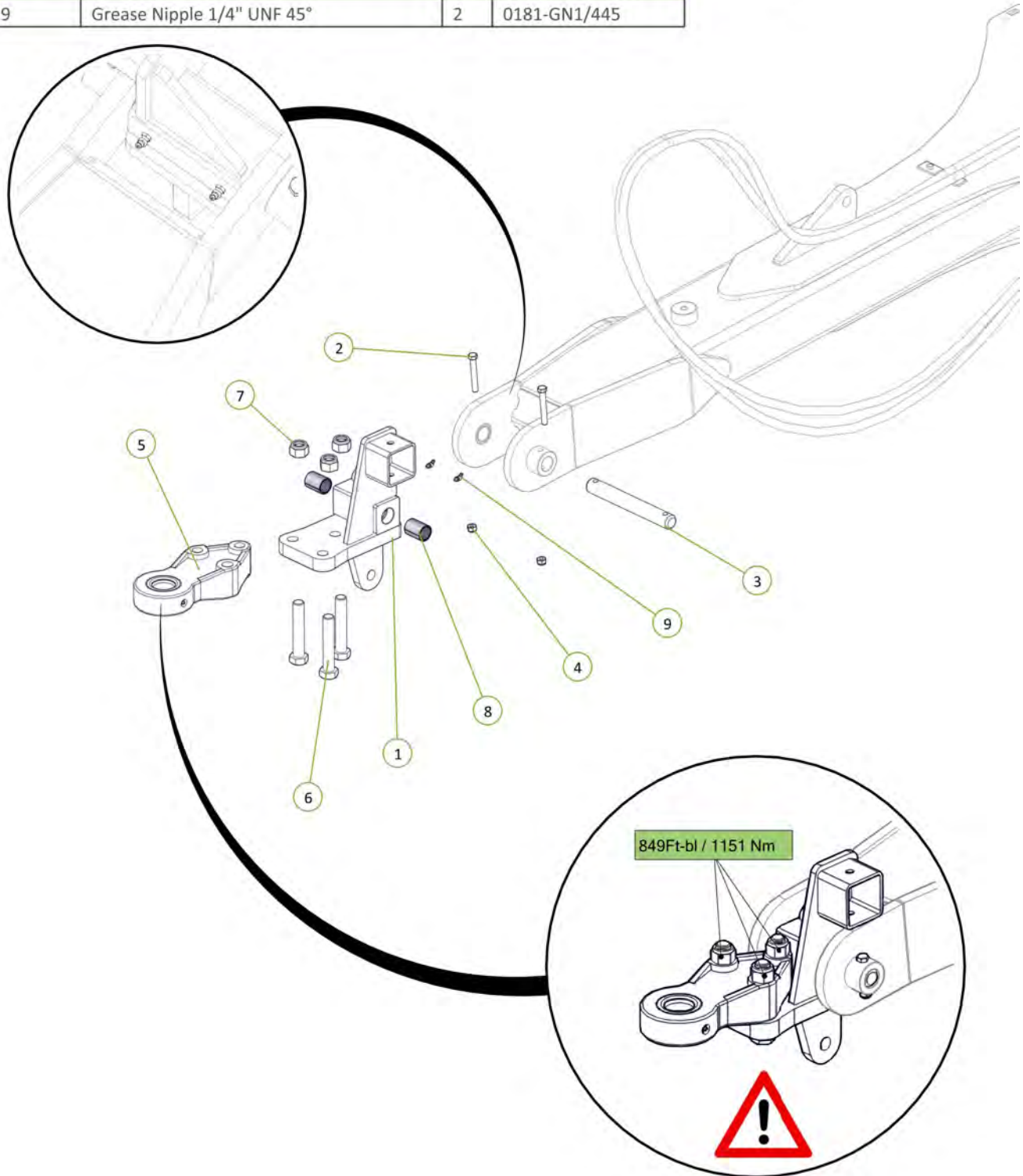
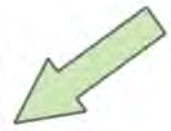

Item No.	Description	Qty	Number
1	Parallel Arm	1	0810-58
2	Clevis Pin 25mm x 75mm	2	0801-KE0307-1
3	Washer Flat 1"	2	0232-F1
4	Cotter Pin M5 x 50	2	0261-PINC550

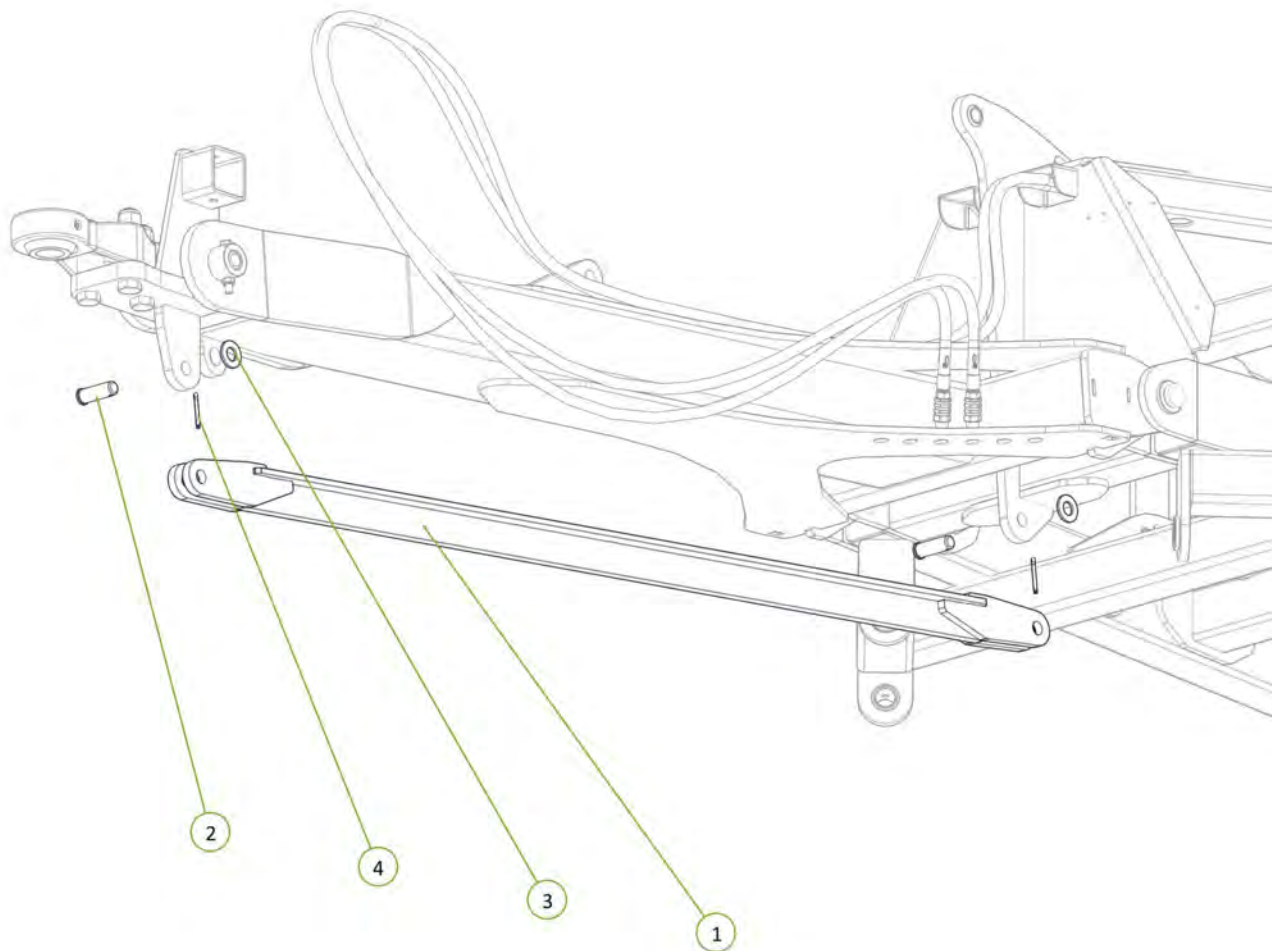

Item No.	Description	Qty	Number
1	4" Bore 12" Stroke 2" Rod Extended Hydraulic Cylinder	1	0311-412EXT-2

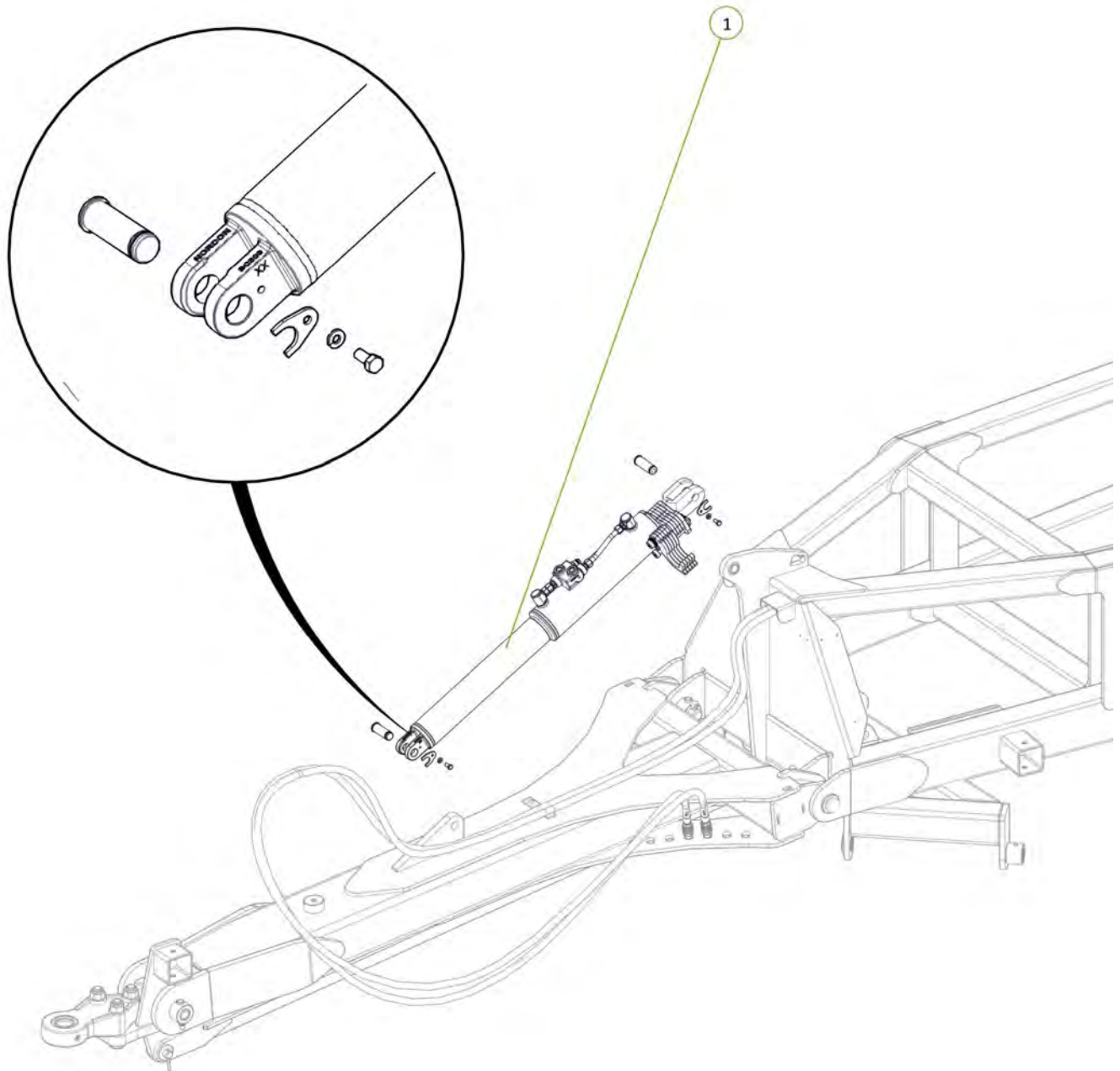

Item No.	Description	Qty	Number
1	US4t Heavy Duty Jack inc Handle	1	0810-37-US
2	Jack Pin	1	0801-B3077

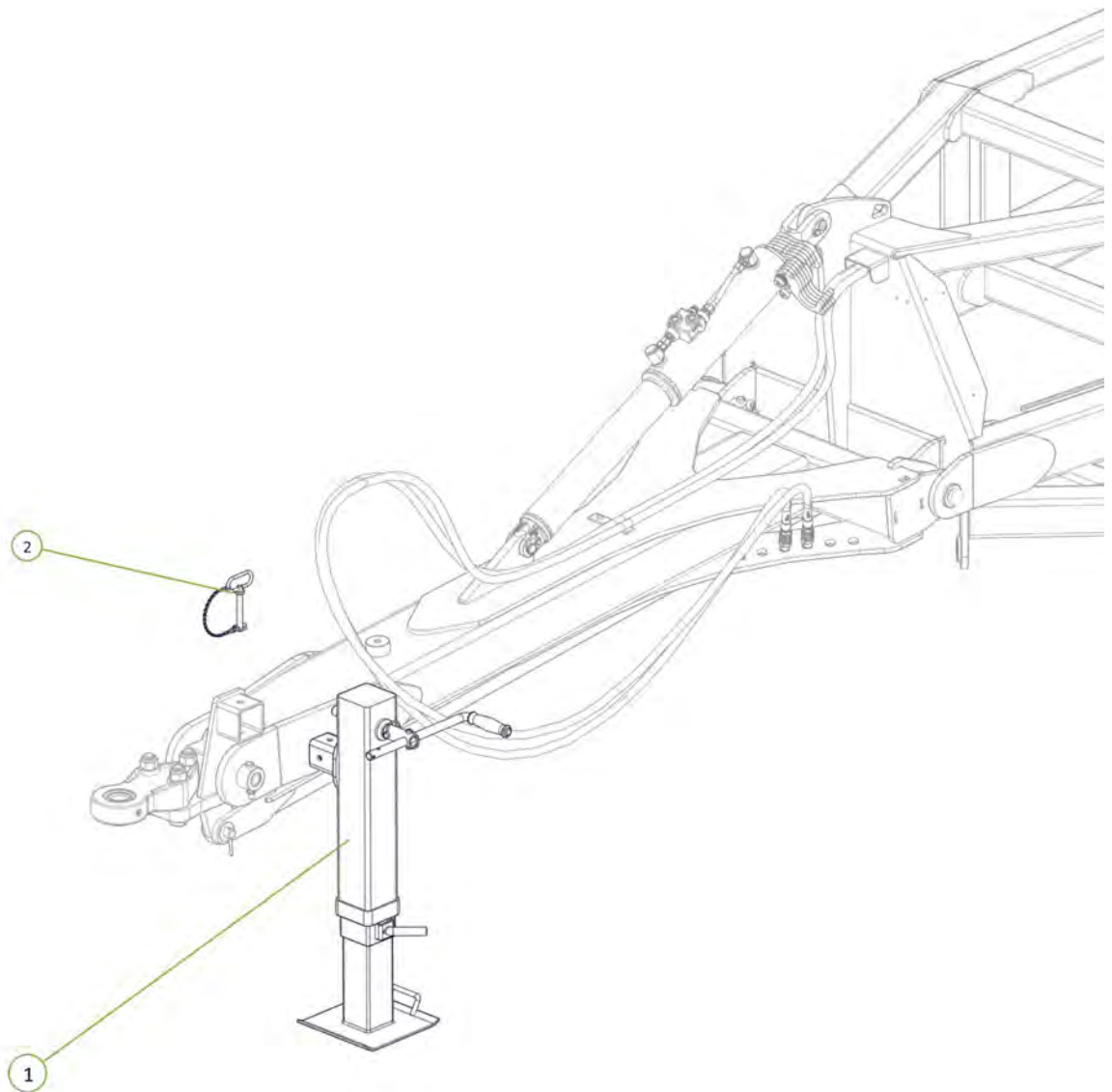

Item No.	Description	Qty	Number
1	Hose Post Spring	1	1601-CDB-00-0012
2	Washer Flat M16	1	0231-F16
3	Washer Spring M16	1	0231-S16
4	M16 x 35 grade 8.8 zp Bolt	1	0211-1635

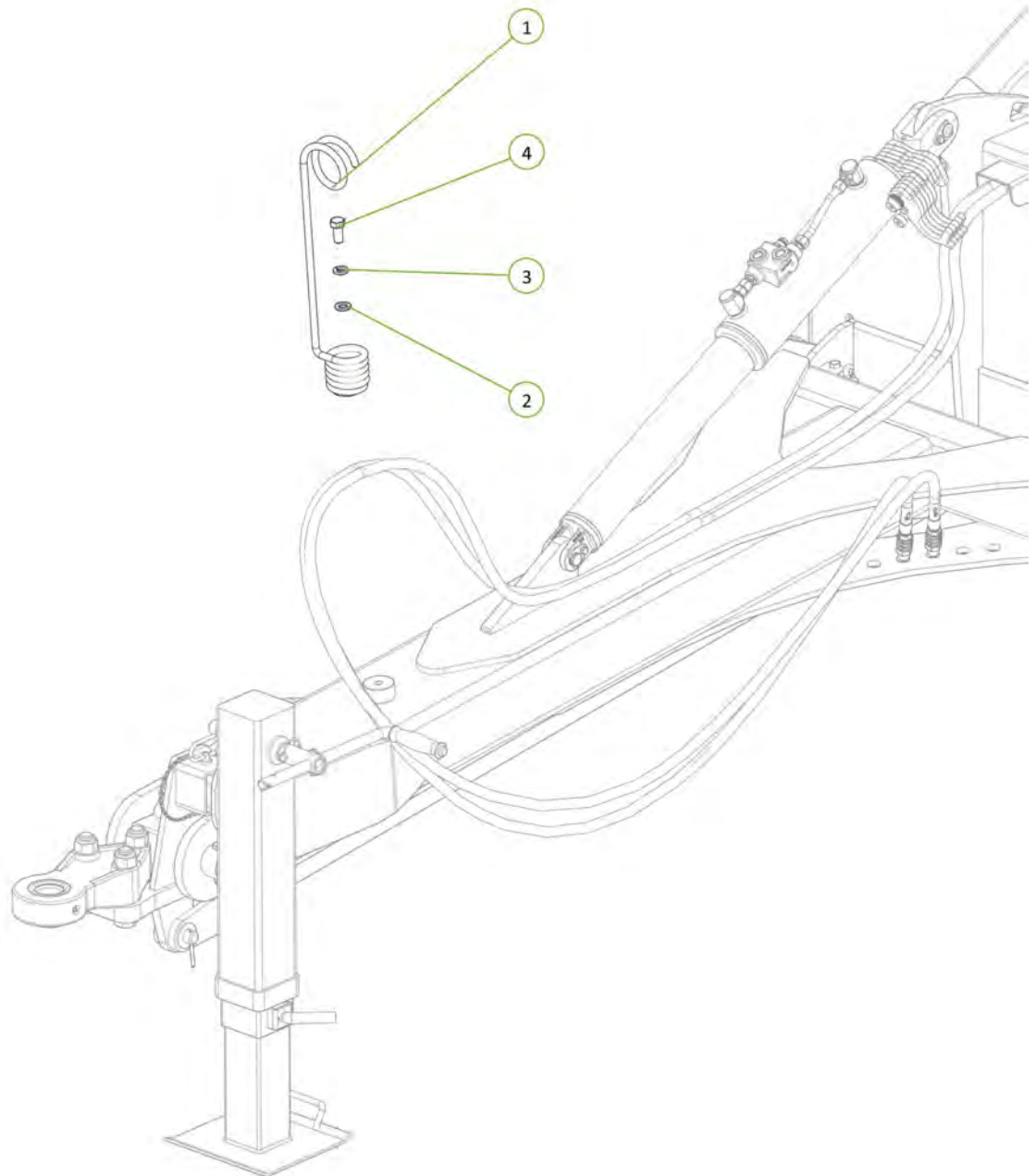

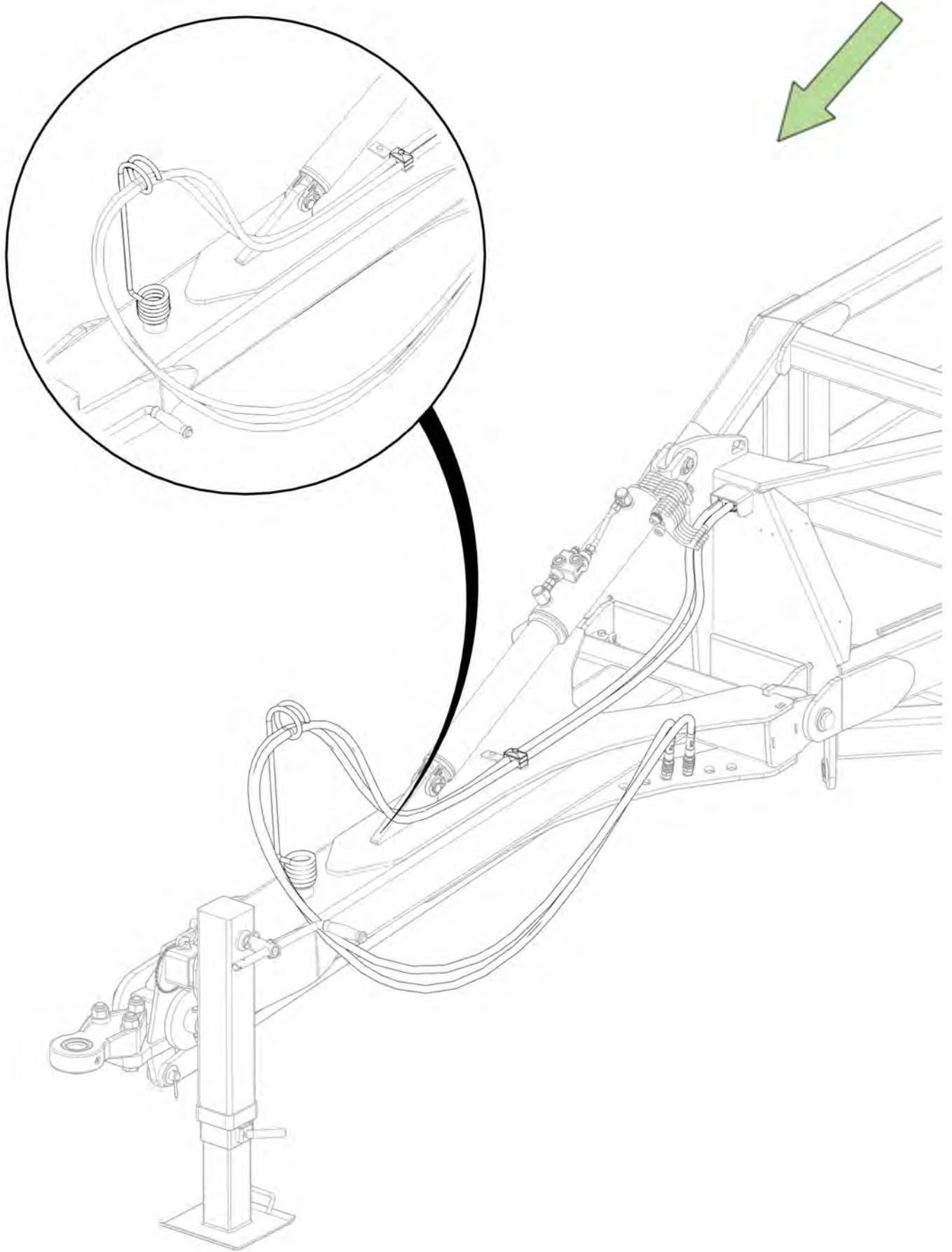

Item No.	Description	Qty	Number
1	Tractor to Sequence Valve EXT2 Port Fitted With Yellow EXT Decal	1	H12-03-YE-EXT2
2	Tractor to Sequence Valve RTC2 Port Fitted With Yellow RTC Decal	1	H12-04-YR-RCT2

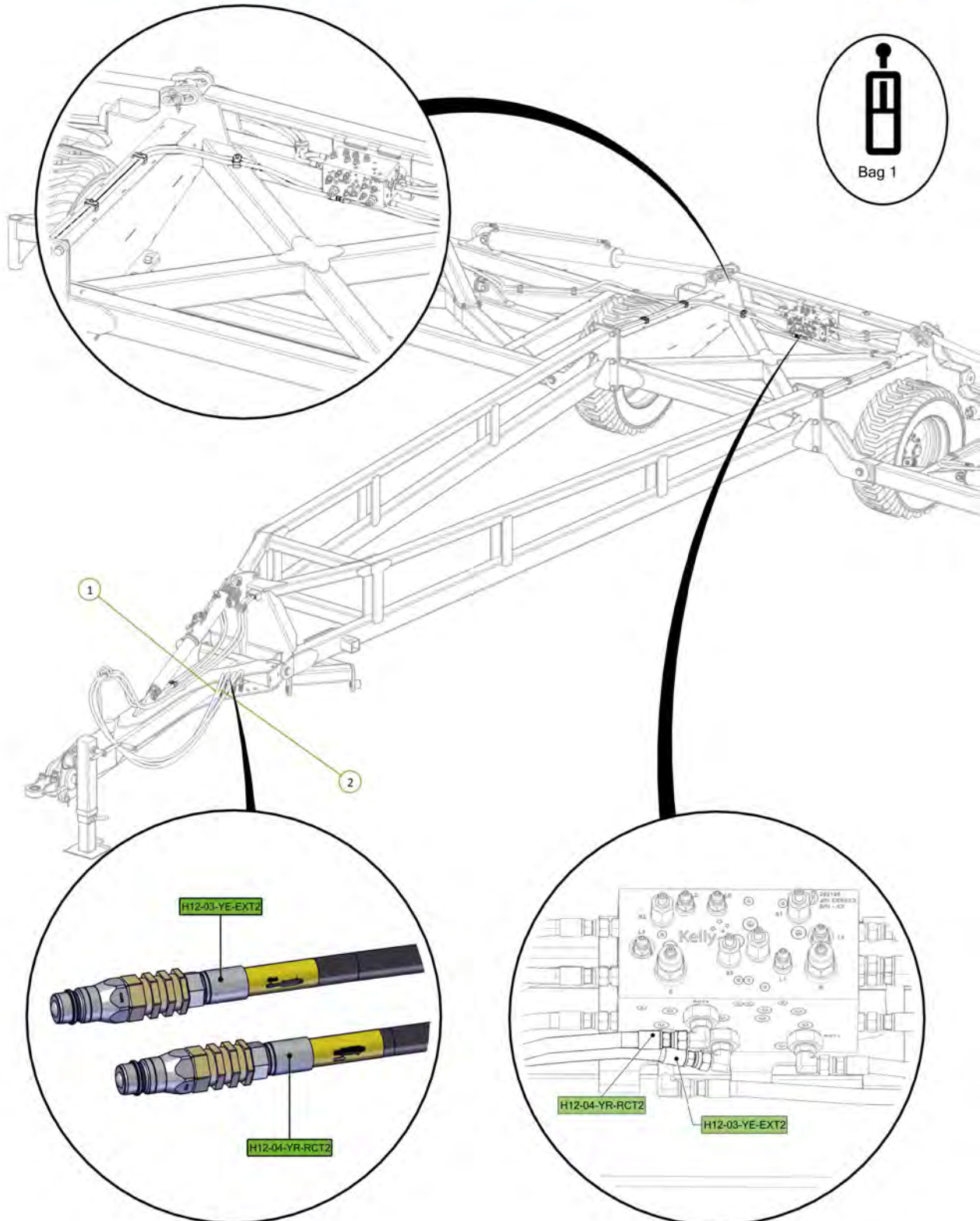

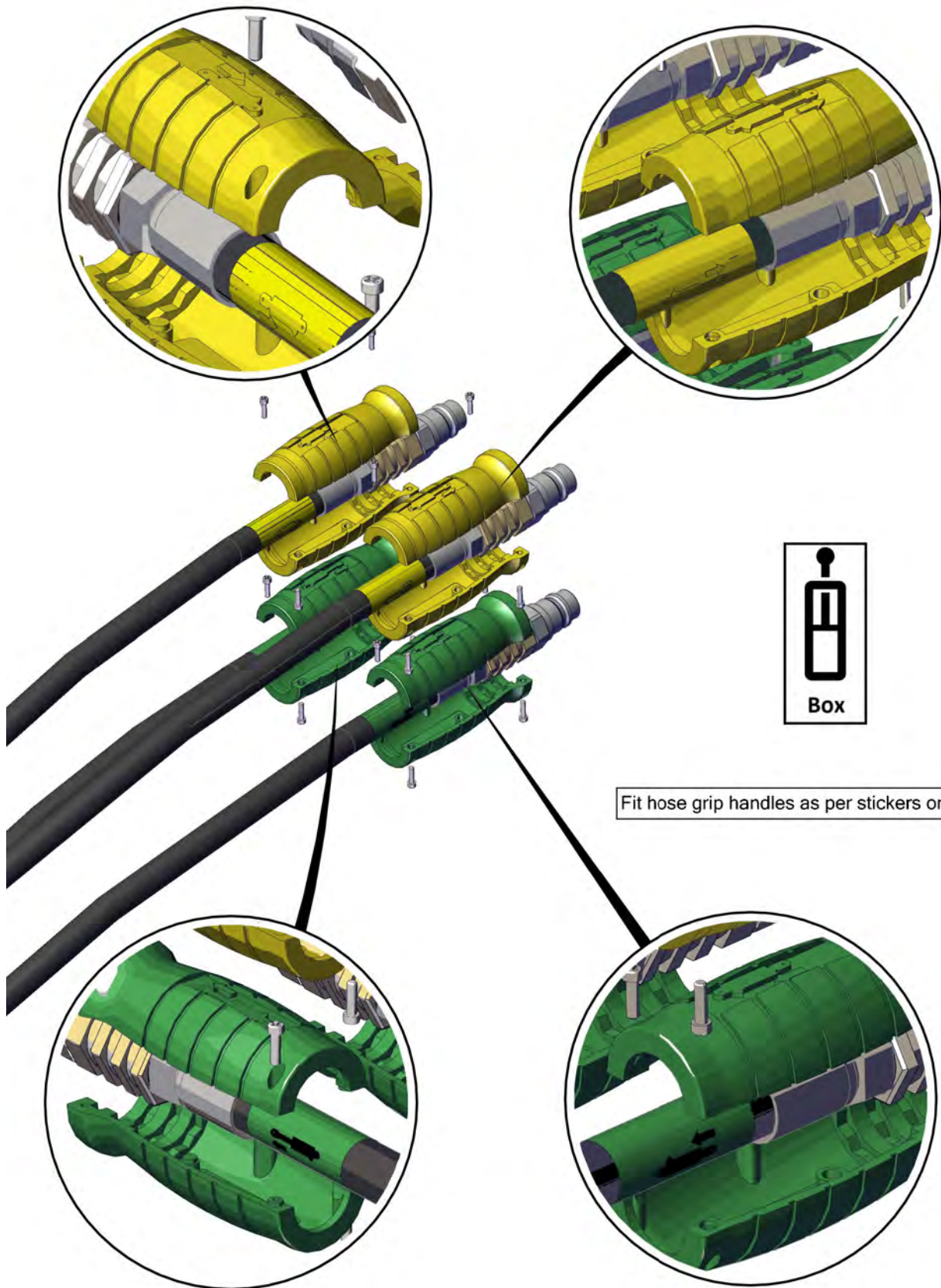

Fit hose grip handles as per stickers on hoses

Item No.	Description	Qty	Number
1	3/4" JIC Male 3/4" UN O Ring Male 90° Elbow	2	0323-S91-1212

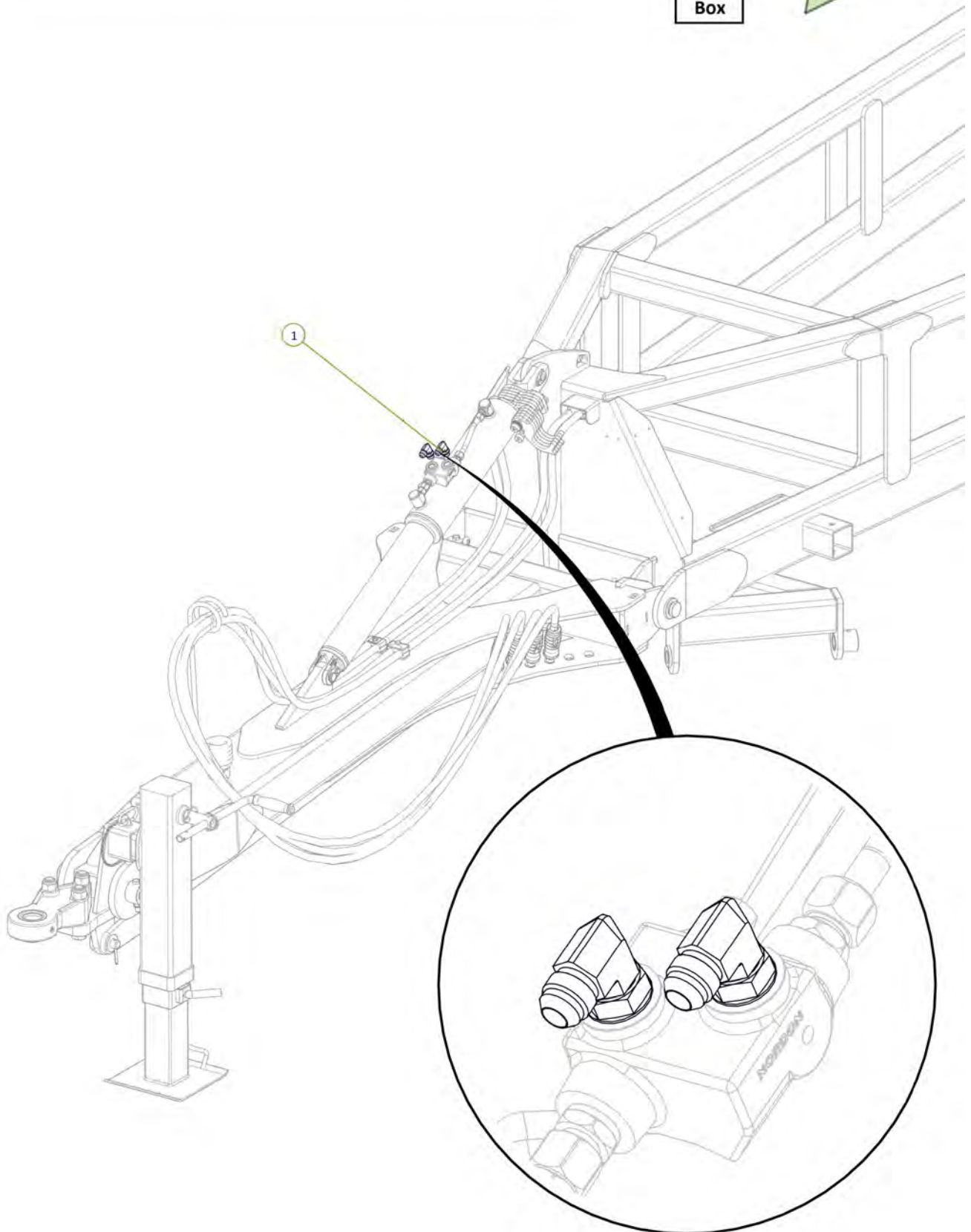

Item No.	Description	Qty	Number
1	Tractor to Front Lift Cylinder Extend Port Fitted With Blue EXT Grip	1	H12-05-BE-EXT
2	Tractor to Front Lift Cylinder Extend Port Fitted With Blue RTC Grip	1	H12-06-BR-RCT

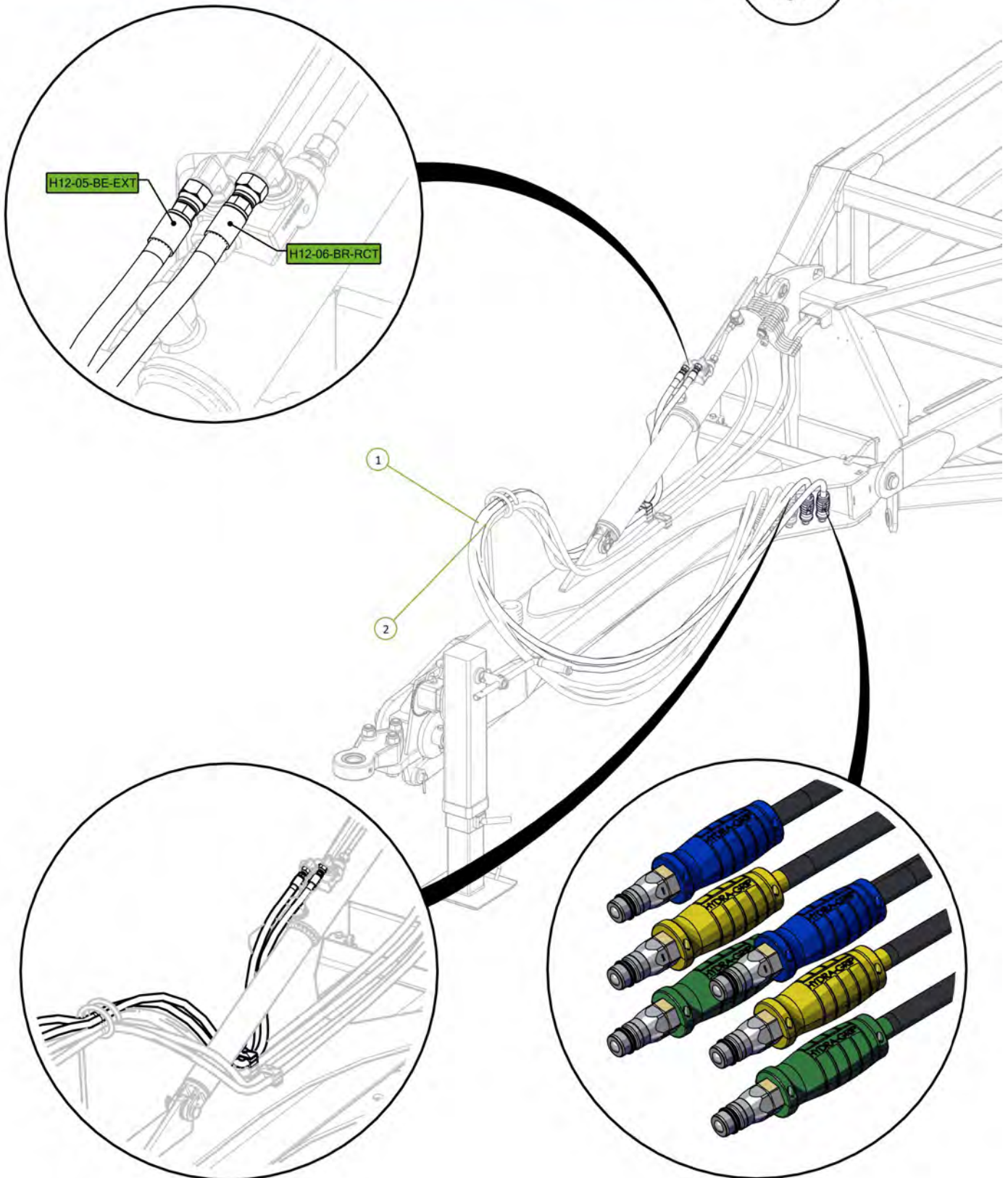

Item No.	Description	Qty	Number
1	Rear A Frame	1	1540-03-3
2	35 ID x 30mm DU Bush	2	0113-MB3530DU

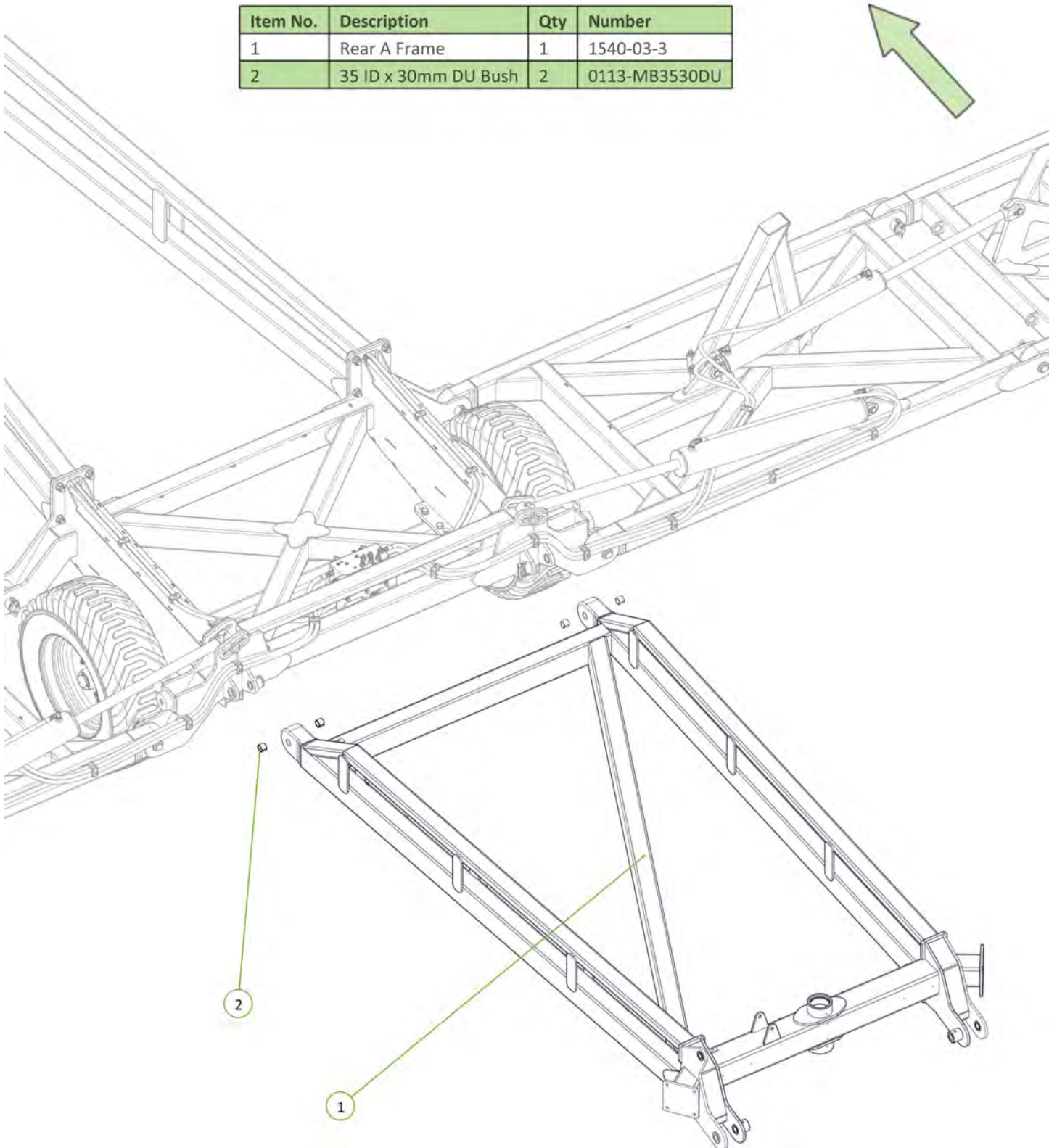

Item No.	Description	Qty	Number
1	PCH Wing Pivot Pin	2	0801-10-08-235
2	Cotter Pin M13 x 63	2	0261-PINC1363
3	Nyloc Nut M12	2	0221-NYL12
4	M12 x 90 Class 8.8 ZP Bolt	2	0211-1290

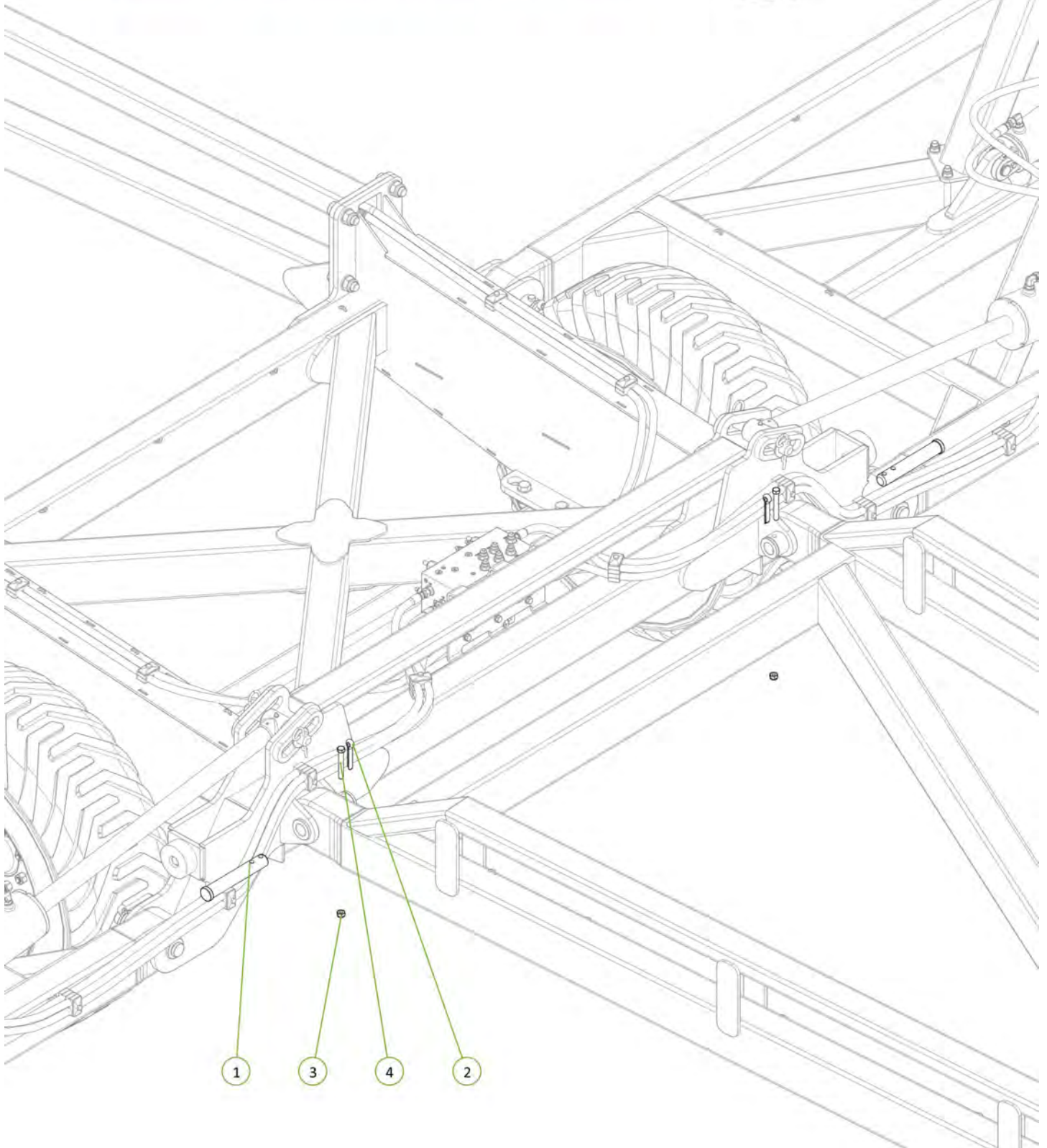

Item No.	Description	Qty	Number
1	70mm Jockey Wheel (Sleeved)	1	1610-12-70
2	Plain Spherical Bearing 70mm	2	0113-GE70DO-2RS
3	Circlip Internal 105mm	2	0171-J105
4	Grease Nipple 1/4" UNF 45°	2	0181-GN1/445
5	TC Seal 90mm x 125mm x 13mm	1	0121-TC12681

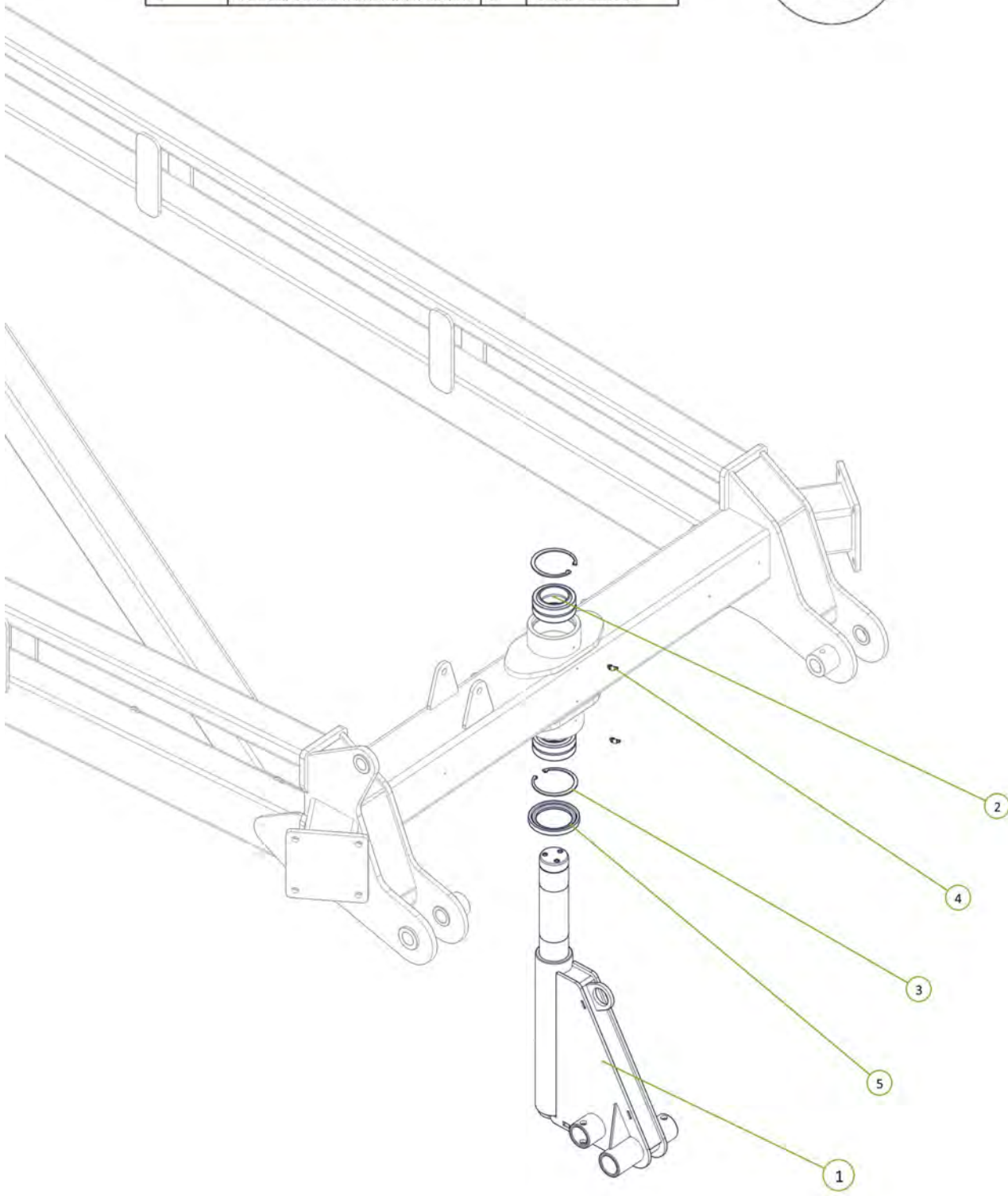

Item No.	Description	Qty	Number
1	Circlip External 70mm	1	0172-D1400-0700APP
2	TC Seal 70mm x 110mm x 10mm	1	0121-TC12654
3	Brake Disc	1	1600-405
4	M12 x 24 Wheel Bolt	3	0216-WB1224

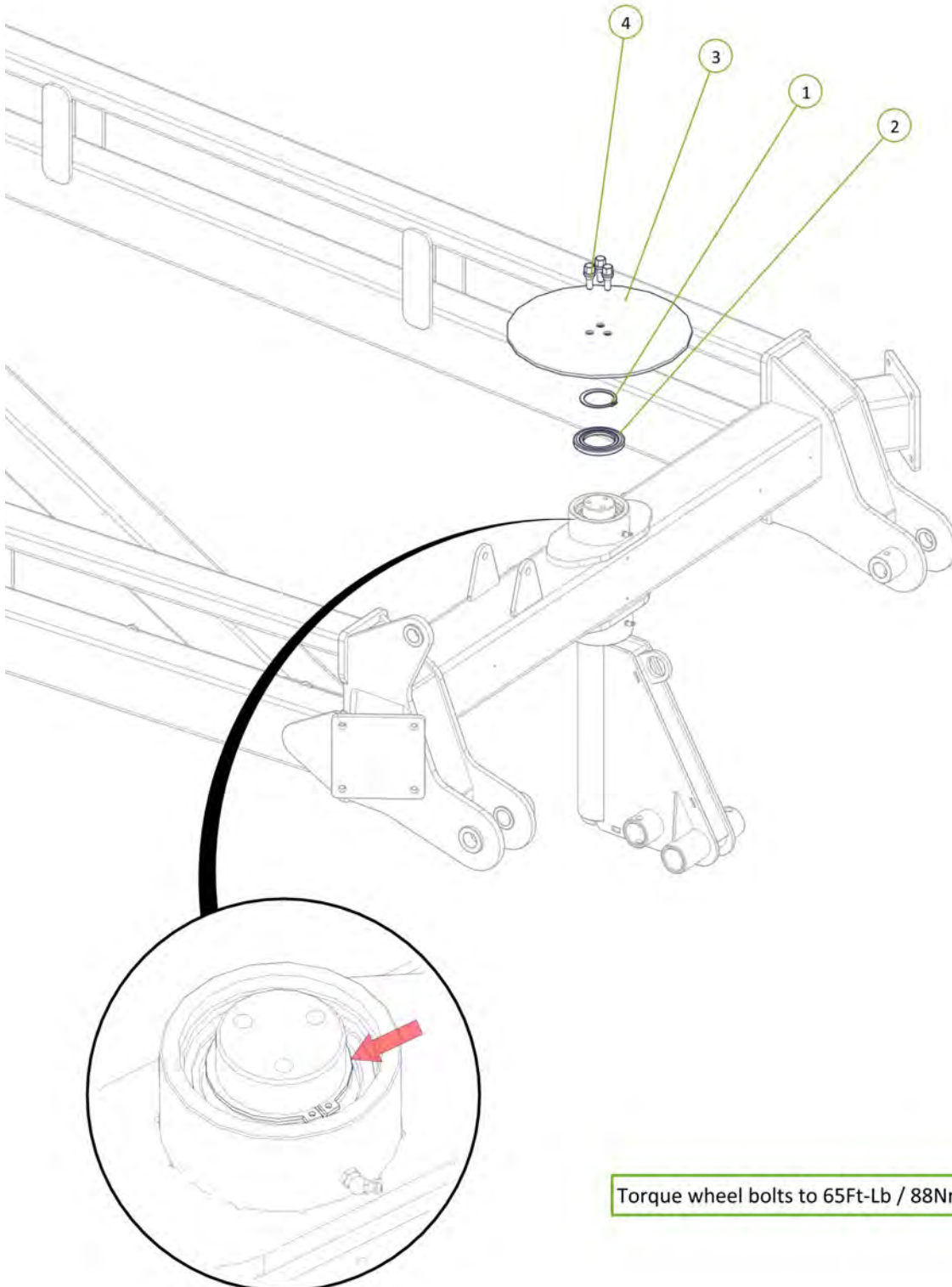

Torque wheel bolts to 65Ft-Lb / 88Nm

Item No.	Description	Qty	Number
1	Jockey Wheel Brake Caliper	1	0810-12CAL
2	Washer Square M16 x 50 x 5	1	0231-SQ16505
3	Brake Compression Spring	1	0801-KE009
4	M16 x 150 Class 8.8 ZP Bolt	1	0211-16150
5	M16 x 160 Class 8.8 ZP Bolt	1	0211-16160
6	Nyloc Nut M16	1	0221-NYL16
7	Washer Flat M16	2	0231-F16
8	Brake Spring Indicator	1	0800-772

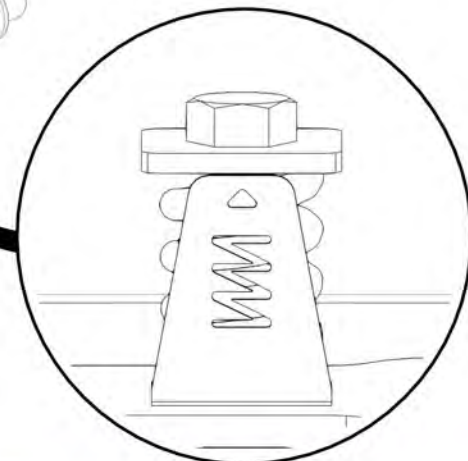
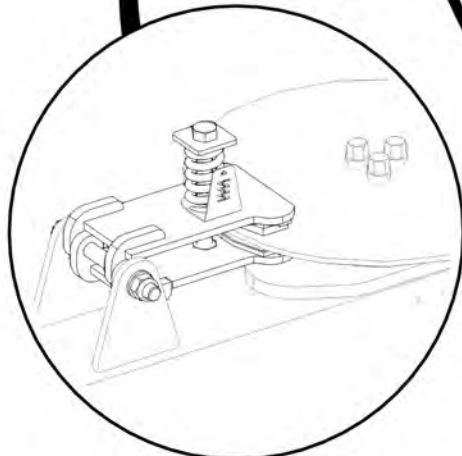
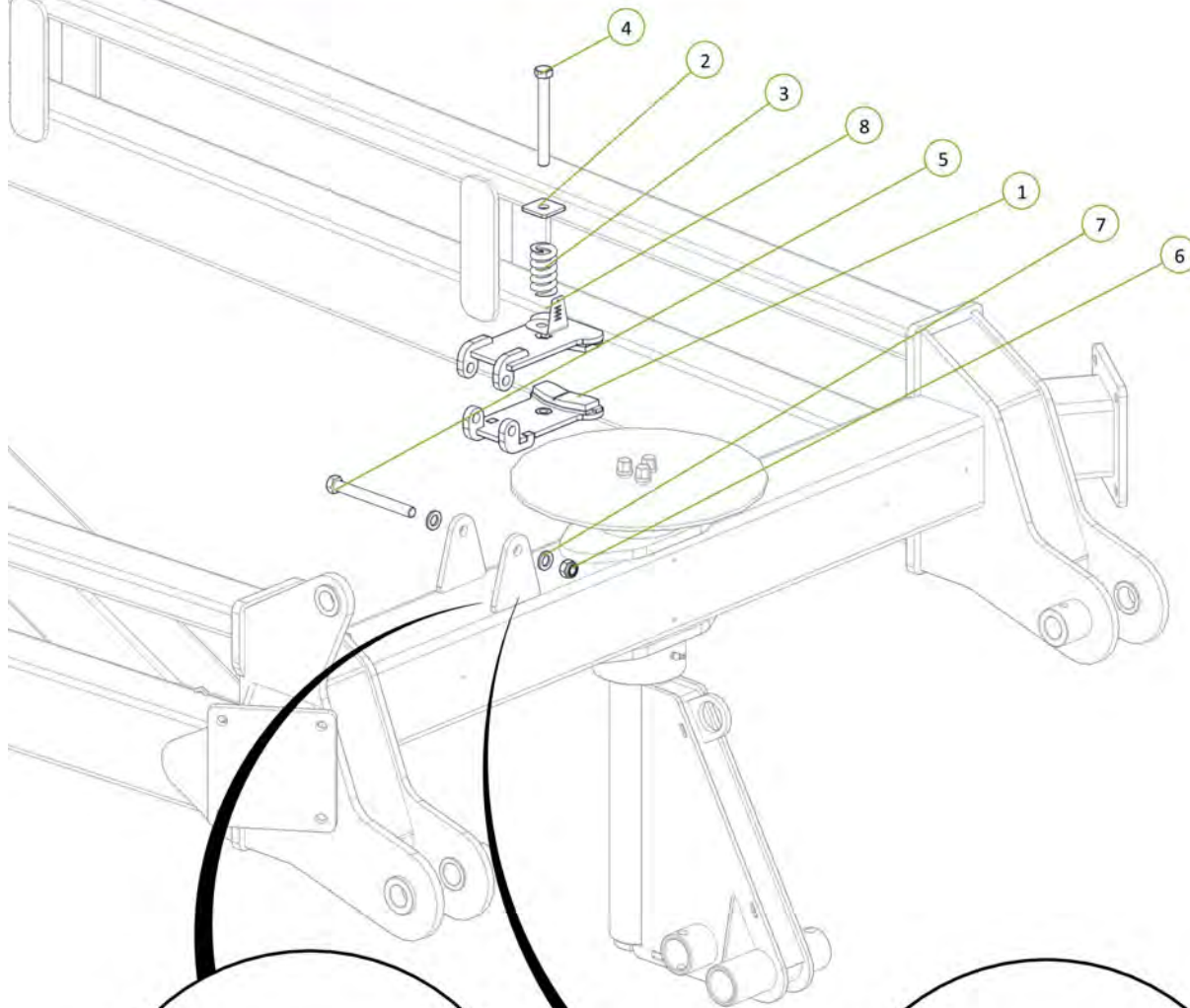

Compress spring to top of indicator as shown

Item No.	Description	Qty	Number
1	Axle 2"R 3T 6 on 6"PCD 330 OHF Complete Assembly Inc GS	2	0733-LG8880093
2	M16 x 90 grade 8.8 zp Bolt	2	0211-1690
3	Nyloc Nut M16	2	0221-NYL16

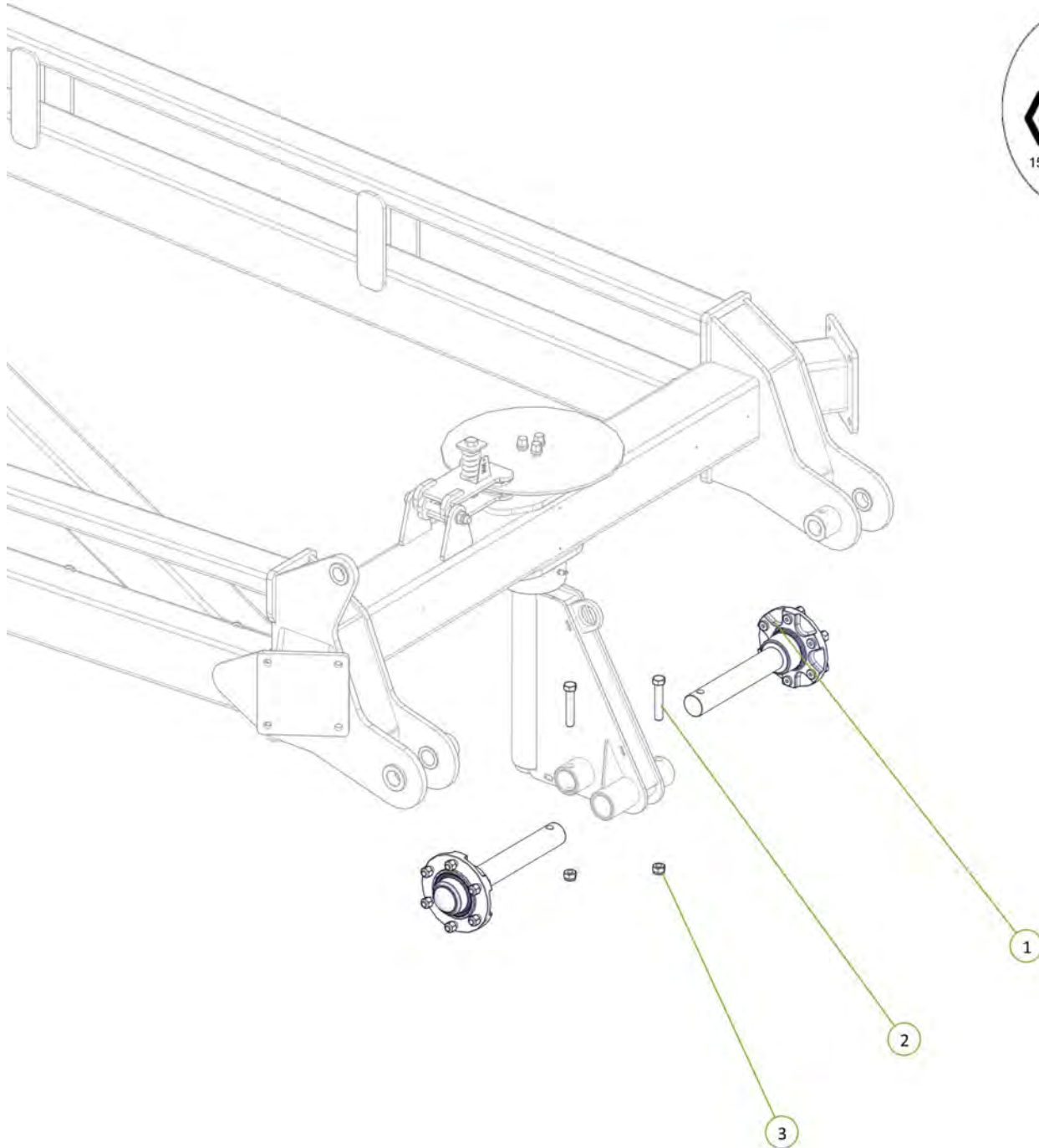

Item No.	Description	Qty	Number
1	11L15 F3 Tyre on 6 on 205 Stud Rim	2	0751-11L15

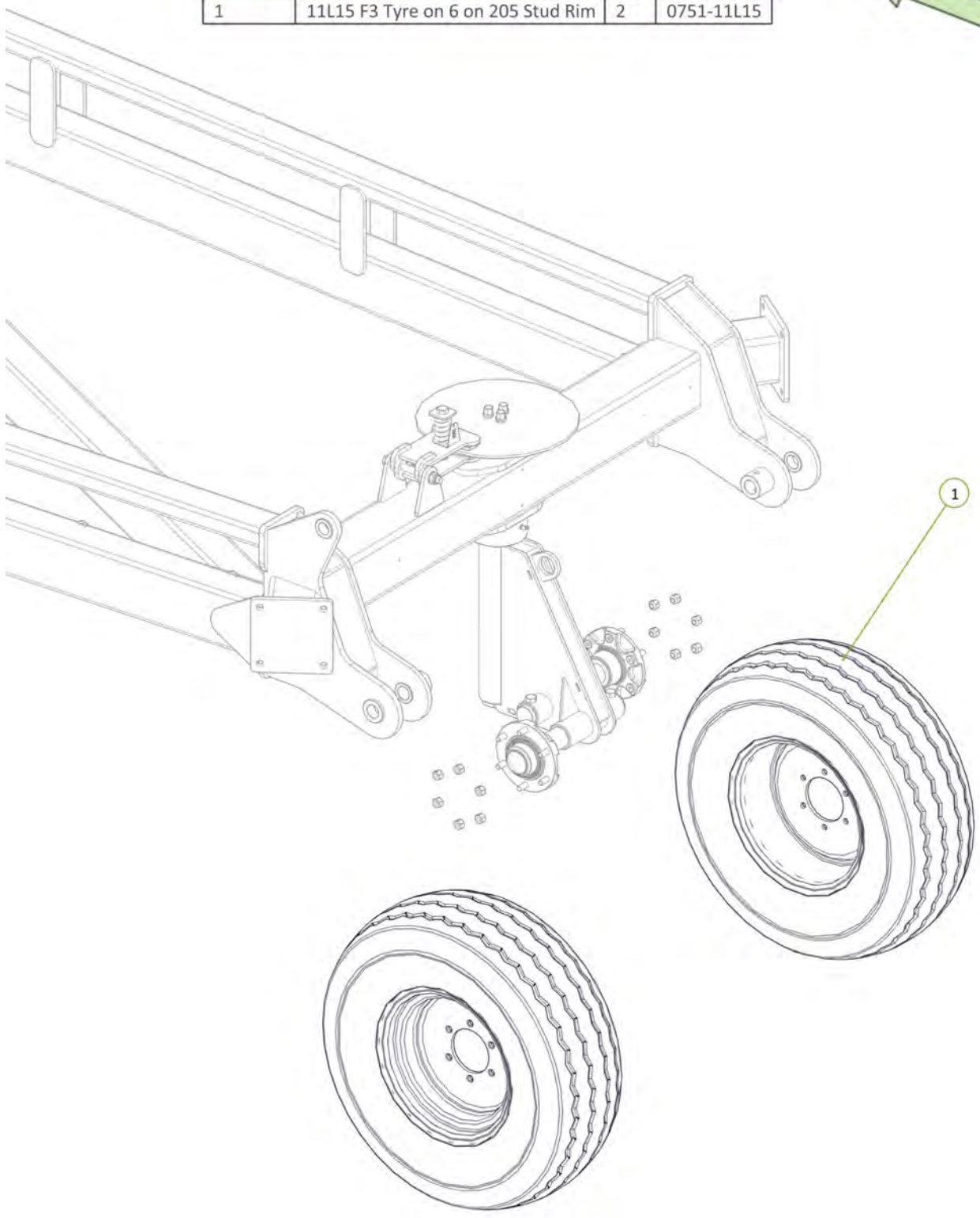

Torque wheel nuts to 90Ft-Lb / 125Nm

Item No.	Description	Qty	Number
1	Rear Tail	1	1510-40S-3
2	35 ID x 30mm DU Bush	4	0113-MB3530DU

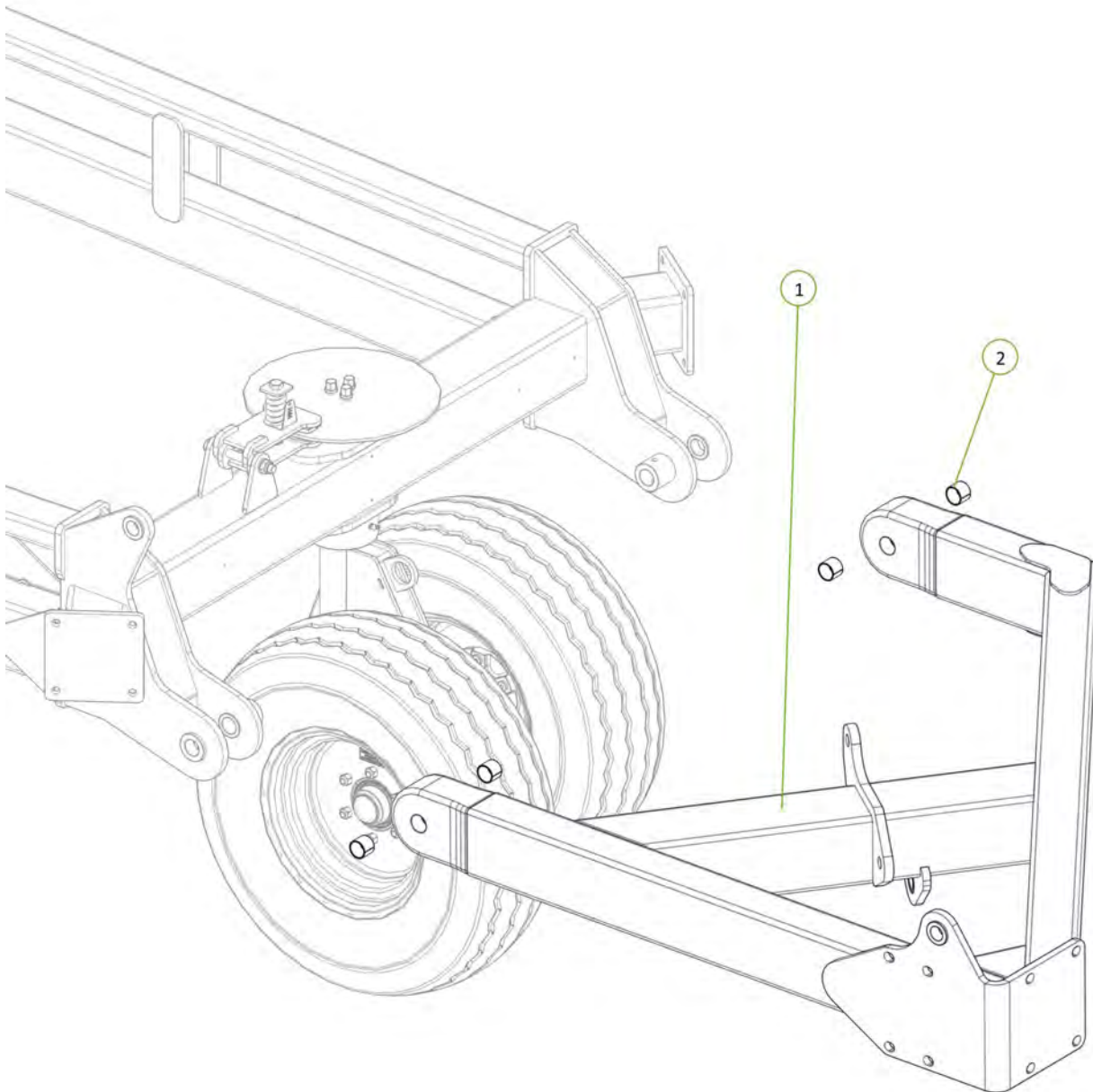

Item No.	Description	Qty	Number
1	PCH Wing Pivot Pin	2	0801-10-08-235
2	M12 x 90 Class 8.8 ZP Bolt	2	0211-1290
3	Cotter Pin M13 x 63	2	0261-PINC1363
4	Nyloc Nut M12	2	0221-NYL12

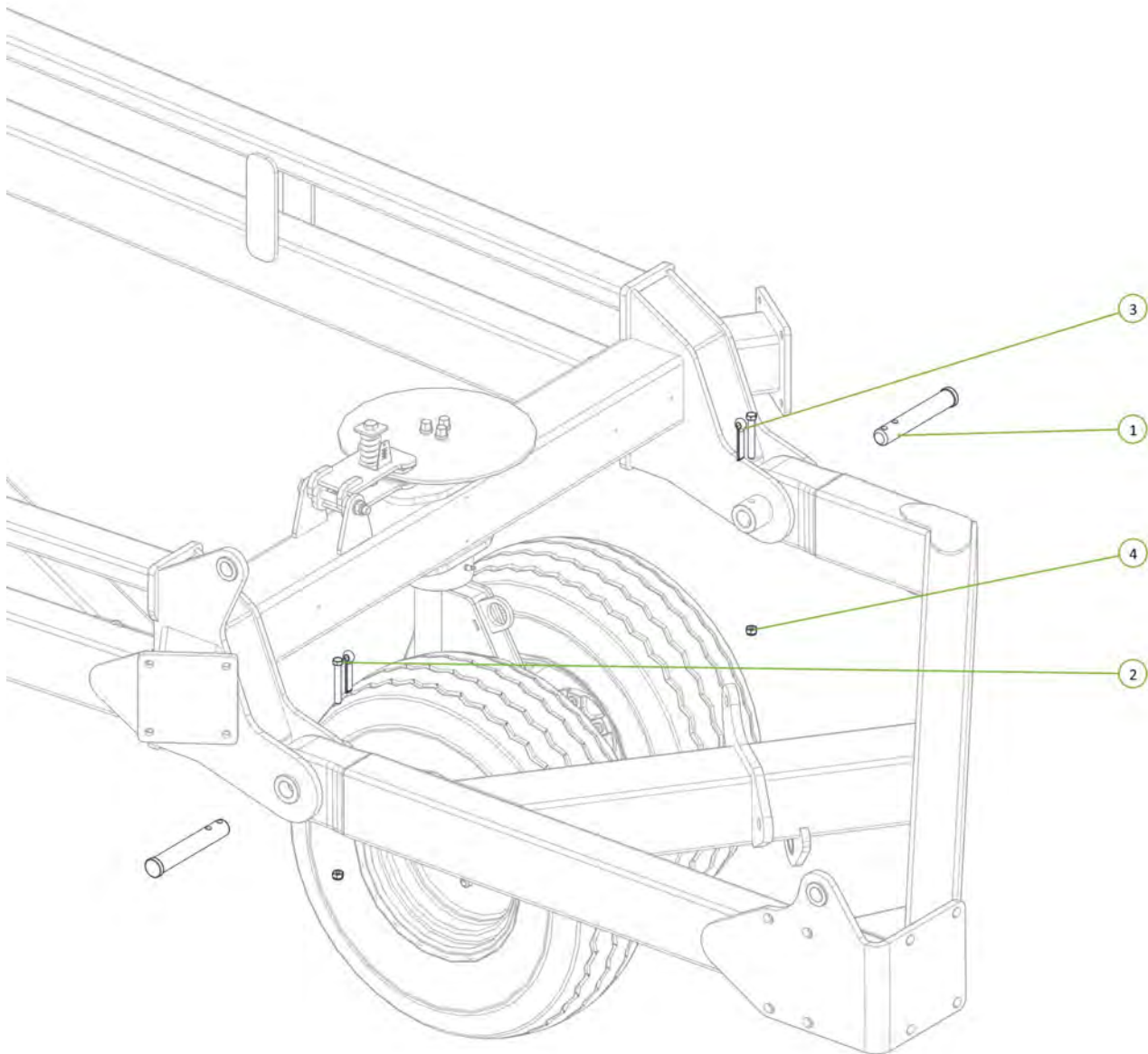

Item No.	Description	Qty	Number
1	4" Bore 24" Stroke 1.75" Rod Hydraulic Cylinder	1	0311-424

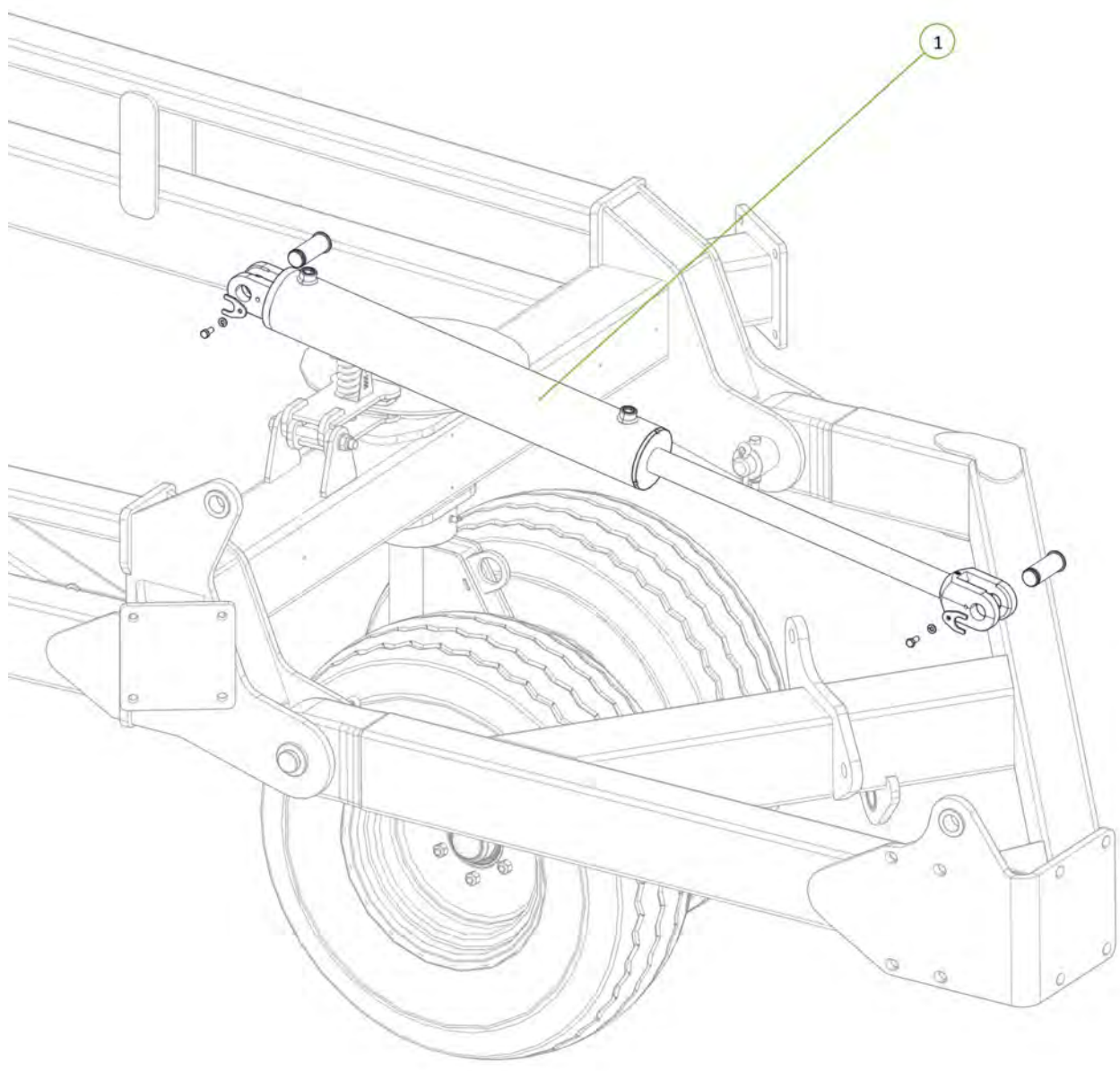

Item No.	Description	Qty	Number
1	3/4" JIC Male 3/4" UN O Ring Male 90° Elbow	2	0323-S91-1212

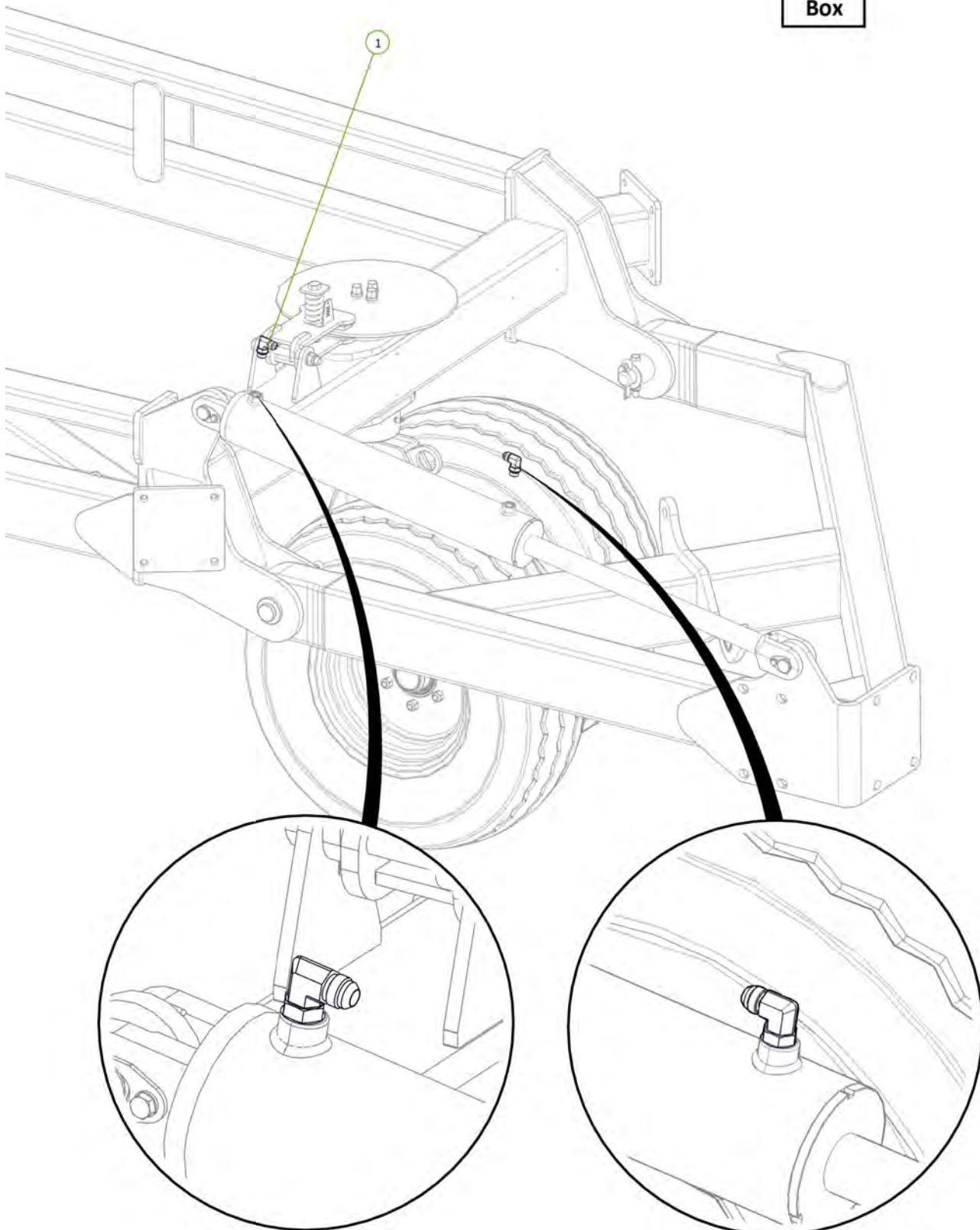

Item No.	Description	Qty	Number
1	TE1 Port to Tail Lift Cylinder Extend Port	1	H12-09
2	TR1 Port to Tail Lift Cylinder Retract Port	1	H12-10

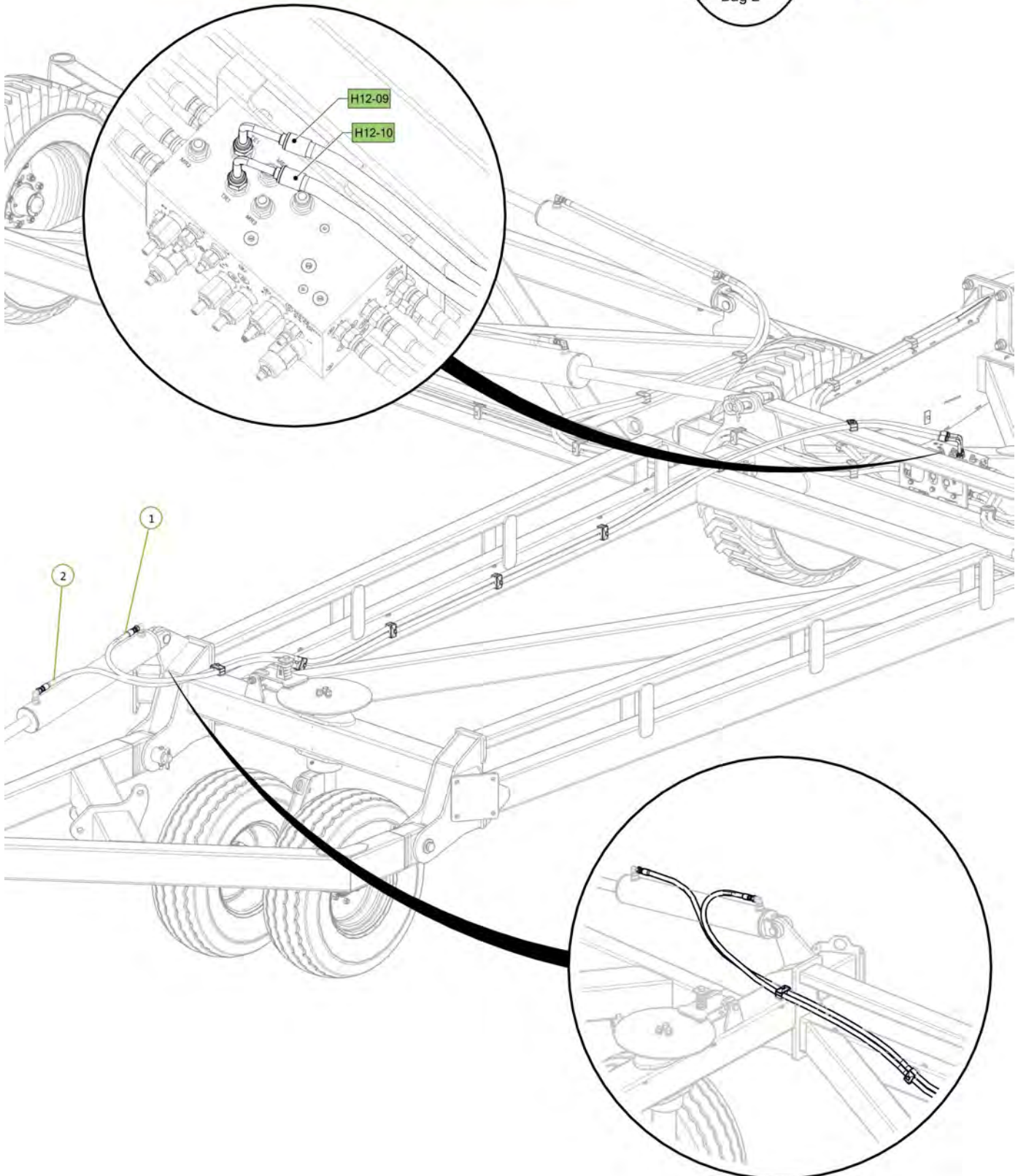

Item No.	Description	Qty	Number
1	Tail Extension	1	1510-40ST-2
2	M20 x 65 grade 8.8 ZP Bolt	8	0211-2065
3	Nyloc Nut M20	8	0221-NYL20
4	Washer Flat M20	16	0231-F20

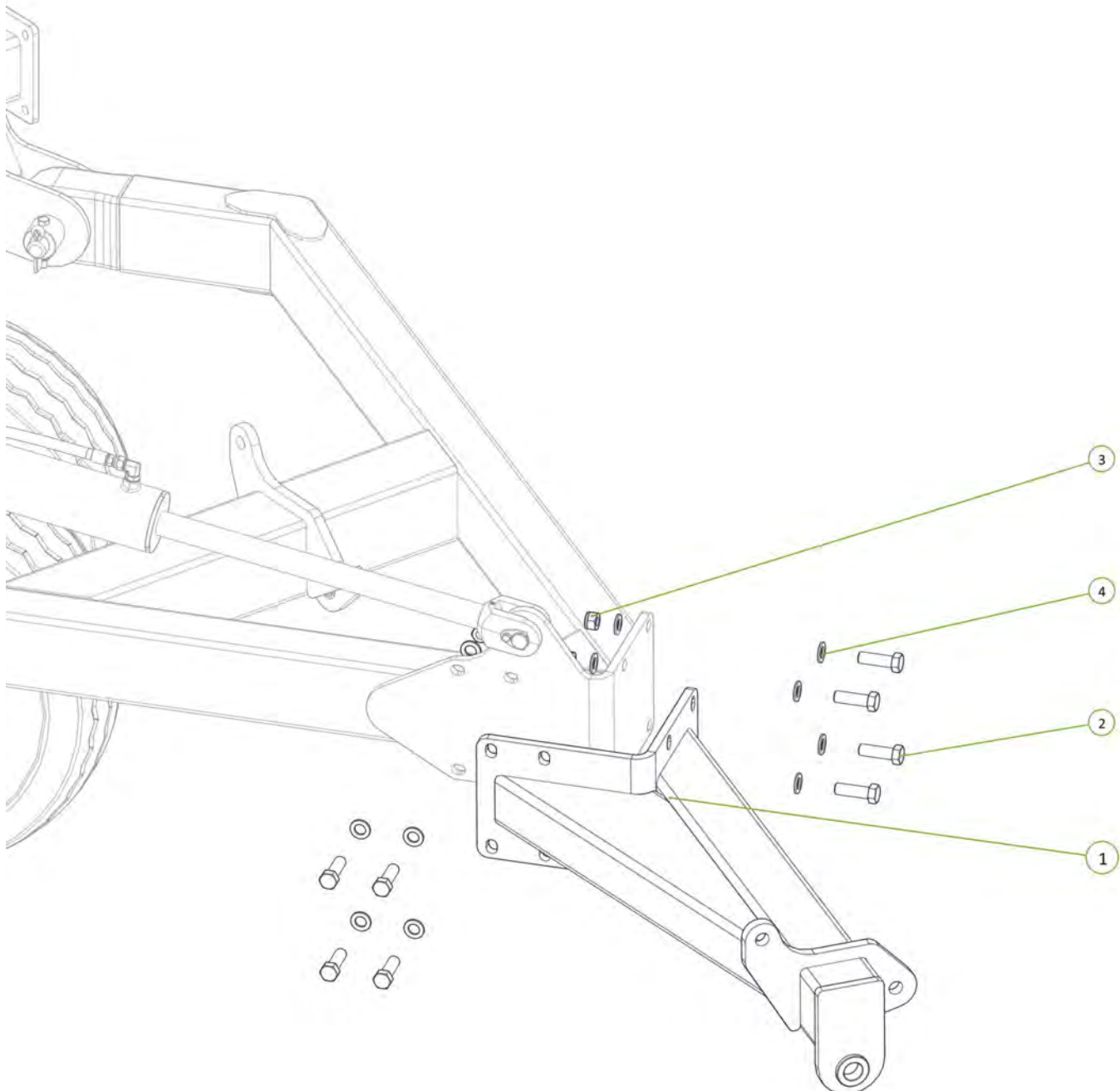

Item No.	Description	Qty	Number
1	Front Module	1	1510-28-12-2
2	U-Bolt M16 x 190 Deep X 106 Wide	8	0271-16190106U
3	Nyloc Nut M16	16	0221-NYL16
4	Washer Flat M16	16	0231-F16

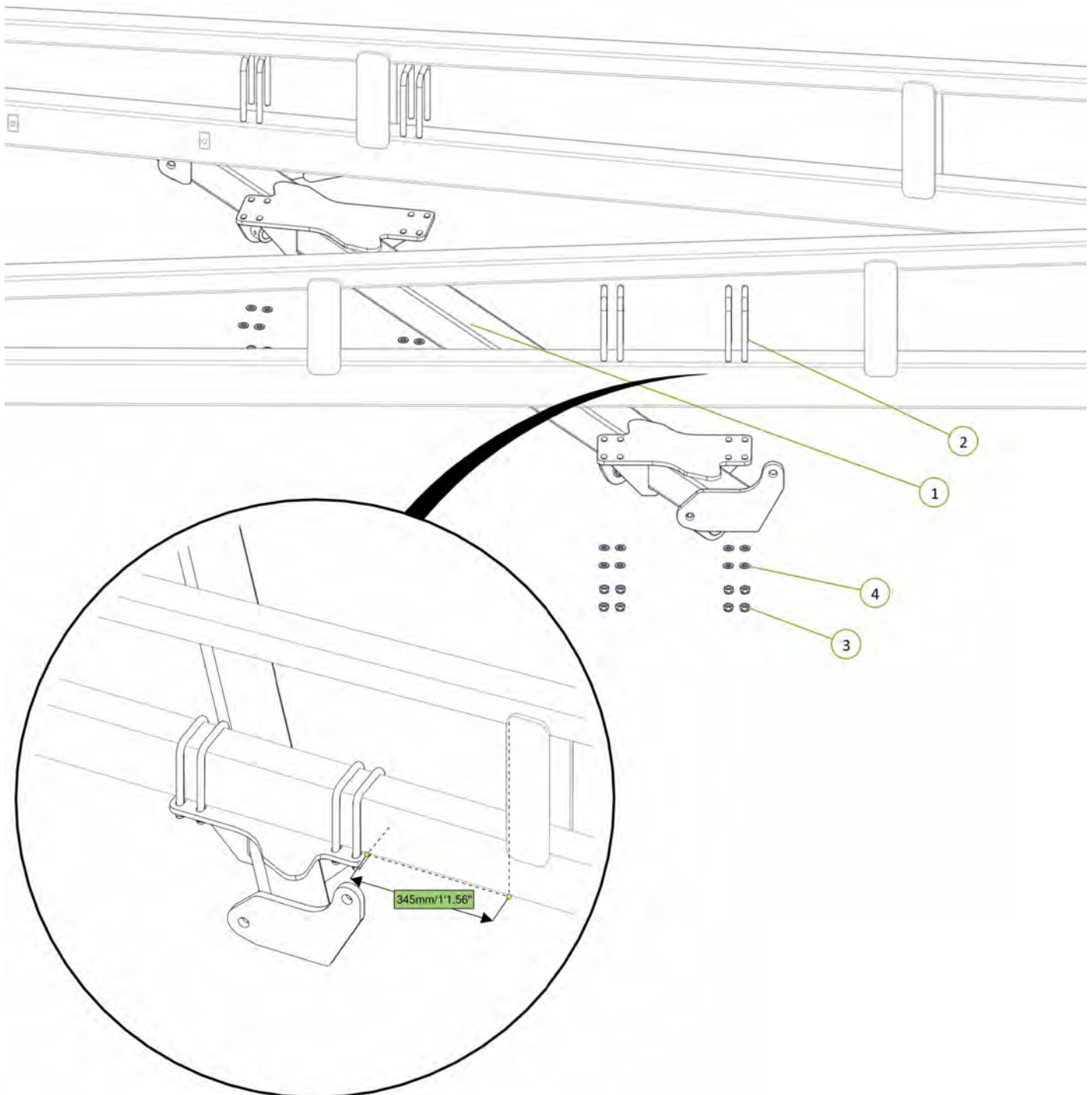

Item No.	Description	Qty	Number
1	Rear Module	1	1510-29-12-3
2	U-Bolt M16 x 190 Deep X 106 Wide	8	0271-16190106U
3	Washer Flat M16	16	0231-F16
4	Nyloc Nut M16	16	0221-NYL16

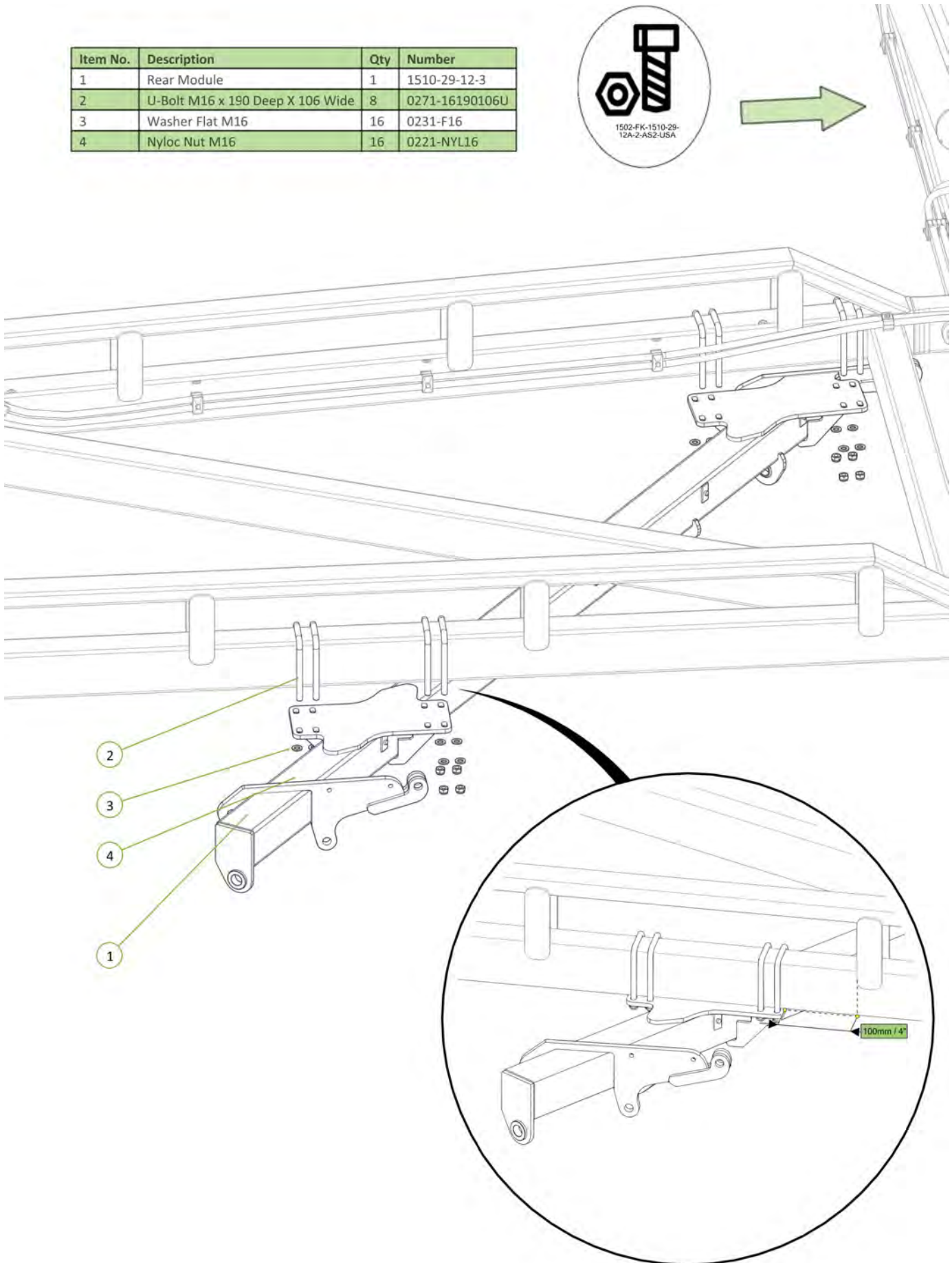

Item No.	Description	Qty	Number
1	Super Single LH Drop Leg No Clevis	1	0810-24SF
2	Super Single RH Drop Leg No Clevis	1	0810-25SF
3	LH Chain Adjusting Lug	1	0810-26
4	RH Chain Adjusting Lug	1	0810-27
5	Forged Clevis 21mm Bolt Hole	2	0801-FC21
6	Stainless Steel Wear Bush	2	1501-365033-SS
7	M24 x 140 grade 8.8 zp Bolt	2	0211-24140
8	Nyloc Nut M24	2	0221-NYL24
9	M36 x 105 grade 8.8 zp Bolt	2	0211-36105
10	Nyloc Nut M36	2	0221-NYL36

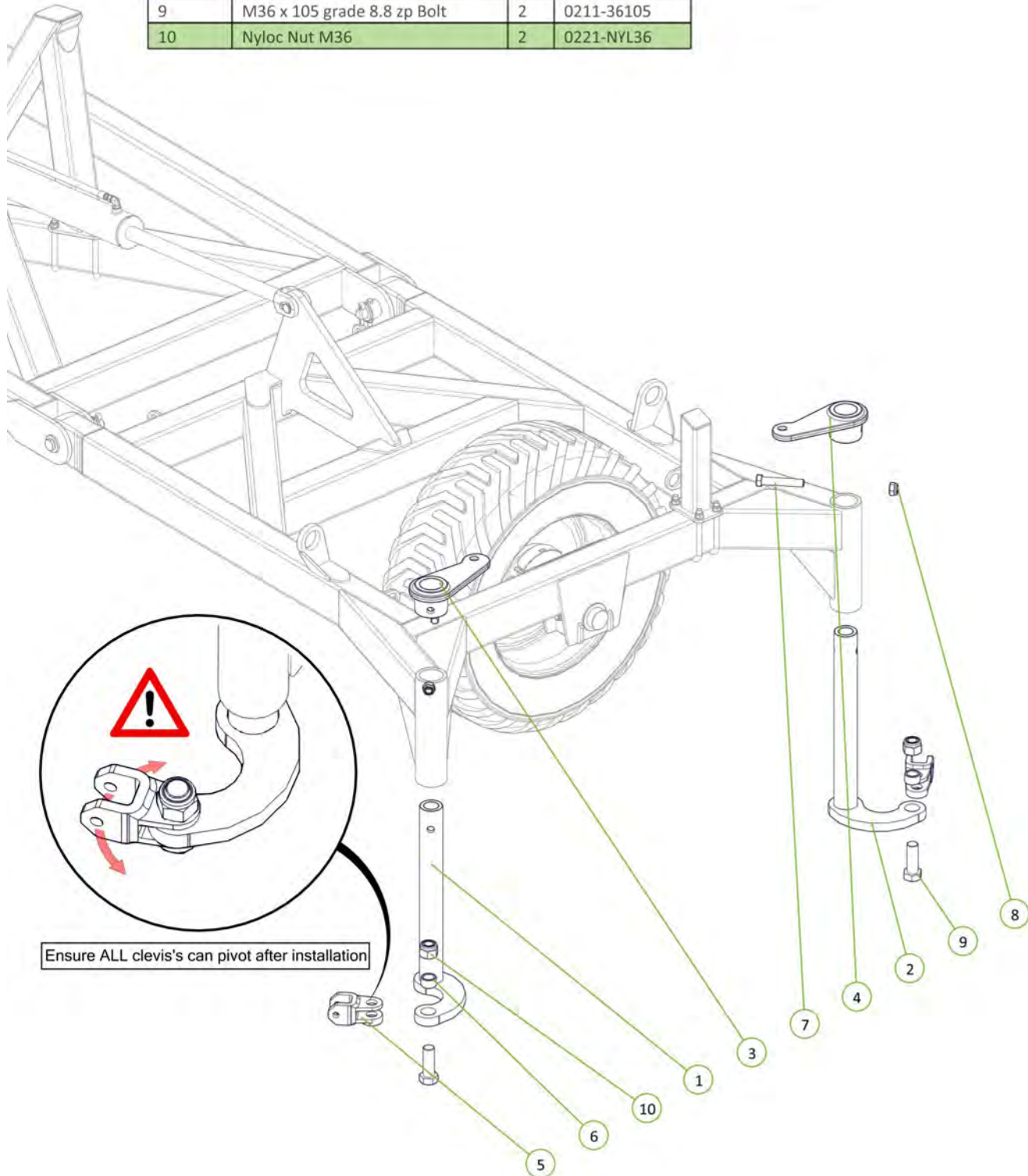

Item No.	Description	Qty	Number
1	Cast 25mm Spacing	24	0801-CS25
2	M10 x 30 grade 8.8 ZP Bolt	24	0211-1030
3	Nyloc Nut M10	24	0221-NYL10

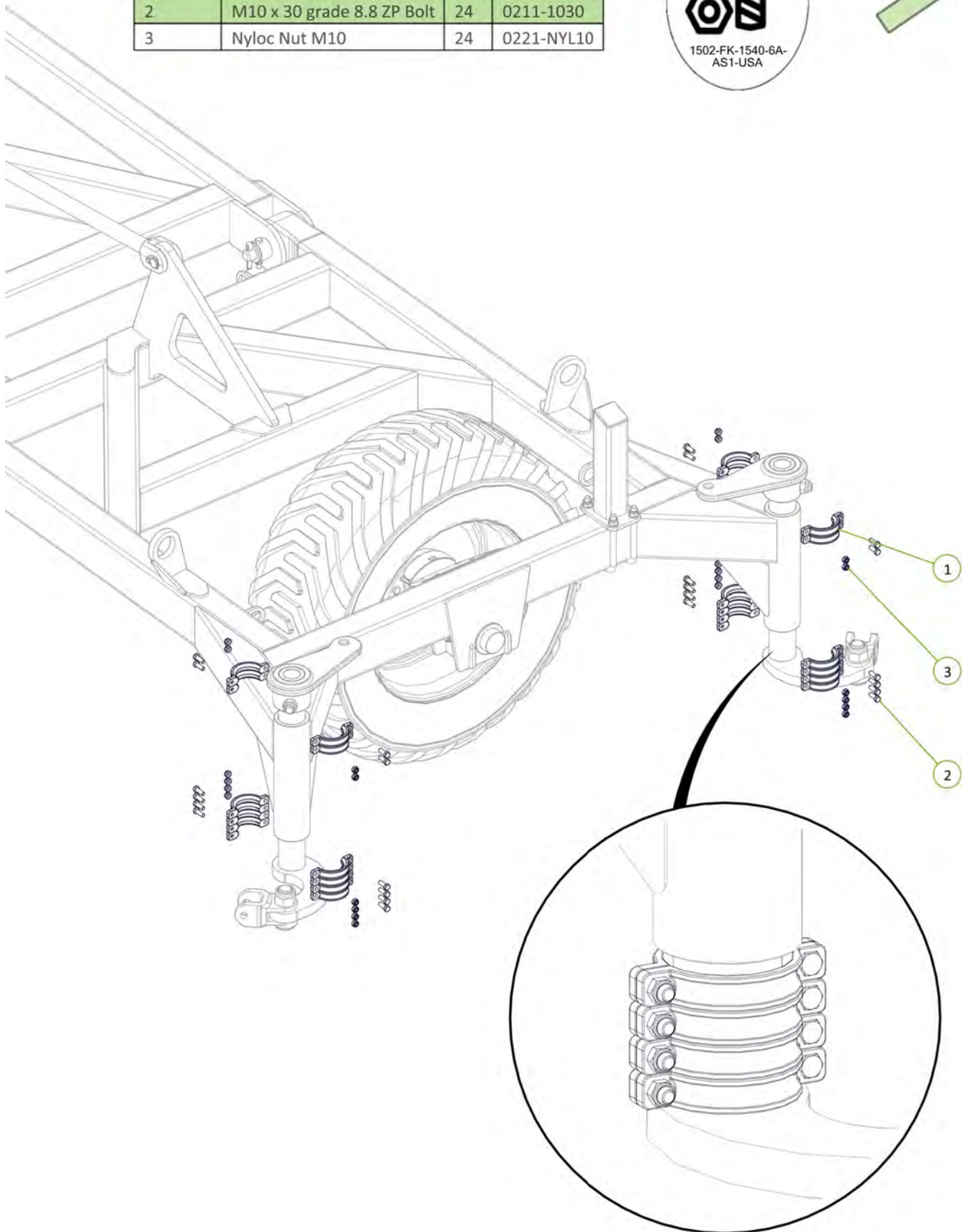

Item No.	Description	Qty	Number
1	Chain Tension Adjustor	2	0802-PCHTA
2	Heavy Duty Coil Spring 24mm	2	0801-K2455350
3	Tensioner Cup - Male	2	0801-KE0805-3
4	Female Spring Locator	2	0801-KE0805-4
5	Washer High Tensile 1 1/4"	2	0232-HT11-4
6	330mm Spring Tension Indicator	2	0800-758

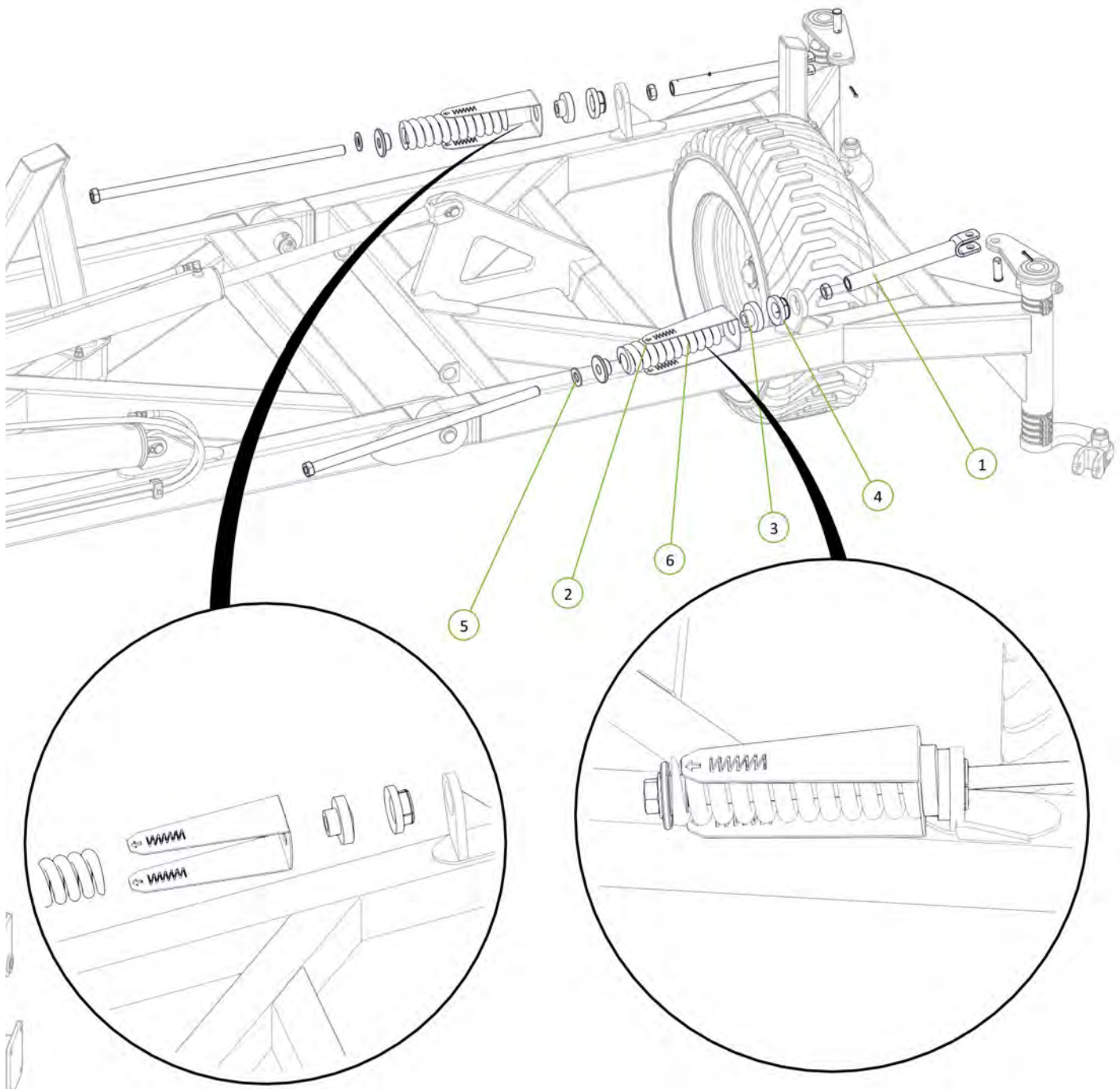

Item No.	Description	Qty	Number
1	Super Single LH Drop Leg No Clevis	1	0810-24SF
2	Super Single RH Drop Leg No Clevis	1	0810-25SF
3	LH Chain Adjusting Lug	1	0810-26
4	RH Chain Adjusting Lug	1	0810-27
5	Forged Clevis 21mm Bolt Hole	2	0801-FC21
6	Stainless Steel Wear Bush	2	1501-365033-SS
7	M24 x 140 grade 8.8 zp Bolt	2	0211-24140
8	Nyloc Nut M24	2	0221-NYL24
9	M36 x 105 grade 8.8 zp Bolt	2	0211-36105
10	Nyloc Nut M36	2	0221-NYL36

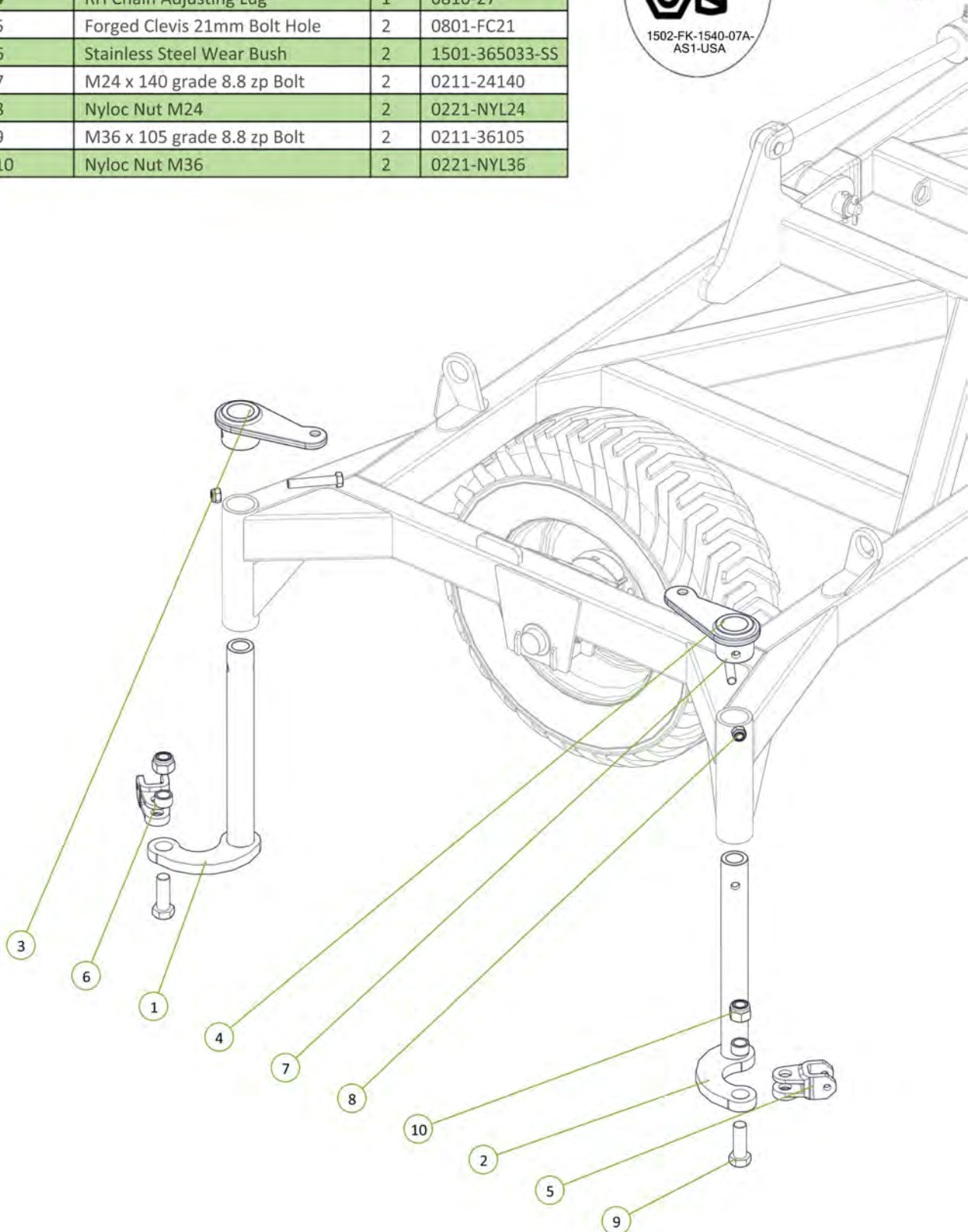

Item No.	Description	Qty	Number
1	Cast 25mm Spacing	24	0801-CS25
2	M10 x 30 grade 8.8 ZP Bolt	24	0211-1030
3	Nyloc Nut M10	24	0221-NYL10

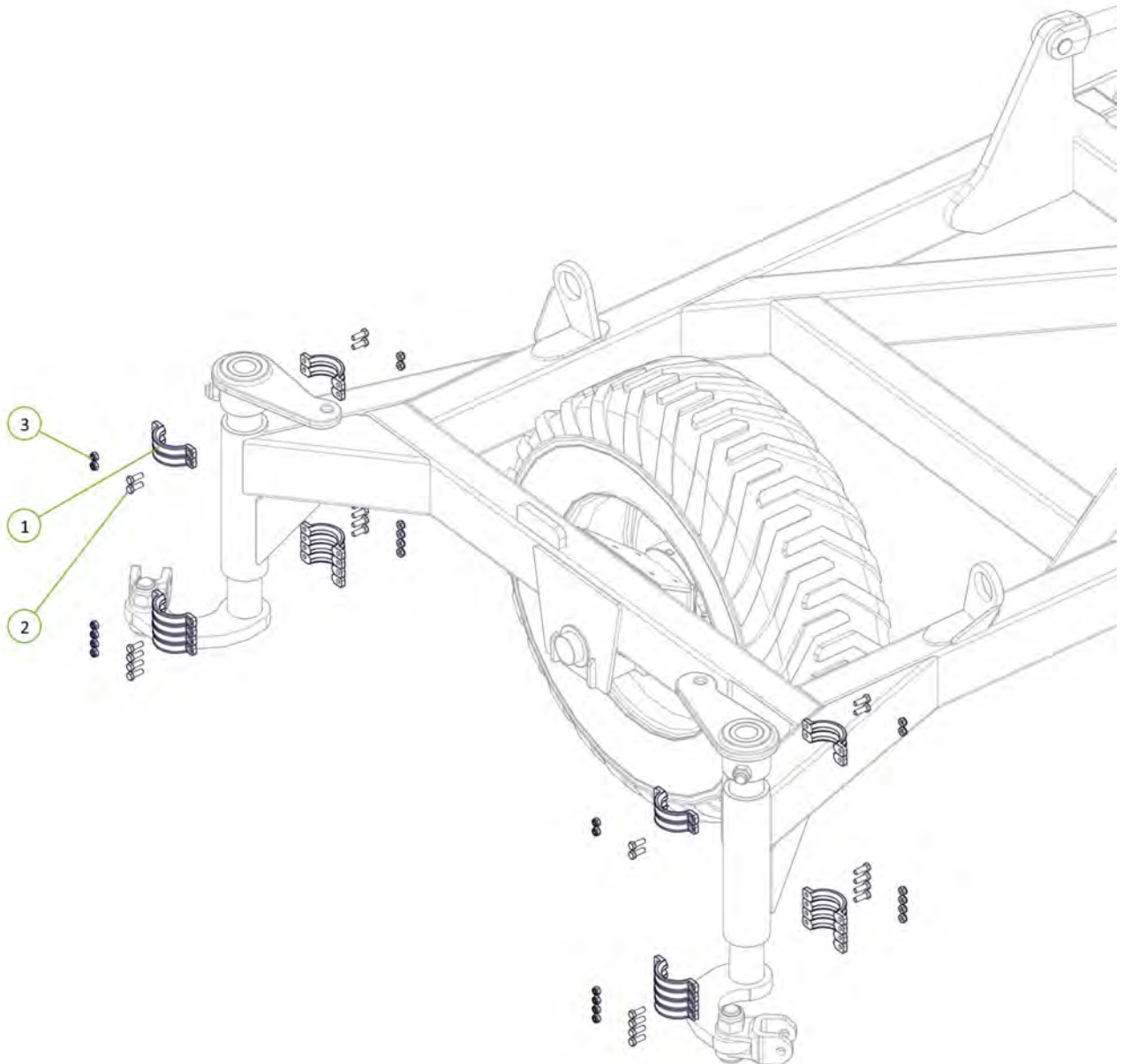

Item No.	Description	Qty	Number
1	Chain Tension Adjustor	2	0802-PCHTA
2	Heavy Duty Coil Spring 24mm	2	0801-K2455350
3	Tensioner Cup - Male	2	0801-KE0805-3
4	Female Spring Locator	2	0801-KE0805-4
5	Washer High Tensile 1 1/4"	2	0232-HT11-4
6	330mm Spring Tension Indicator	2	0800-758

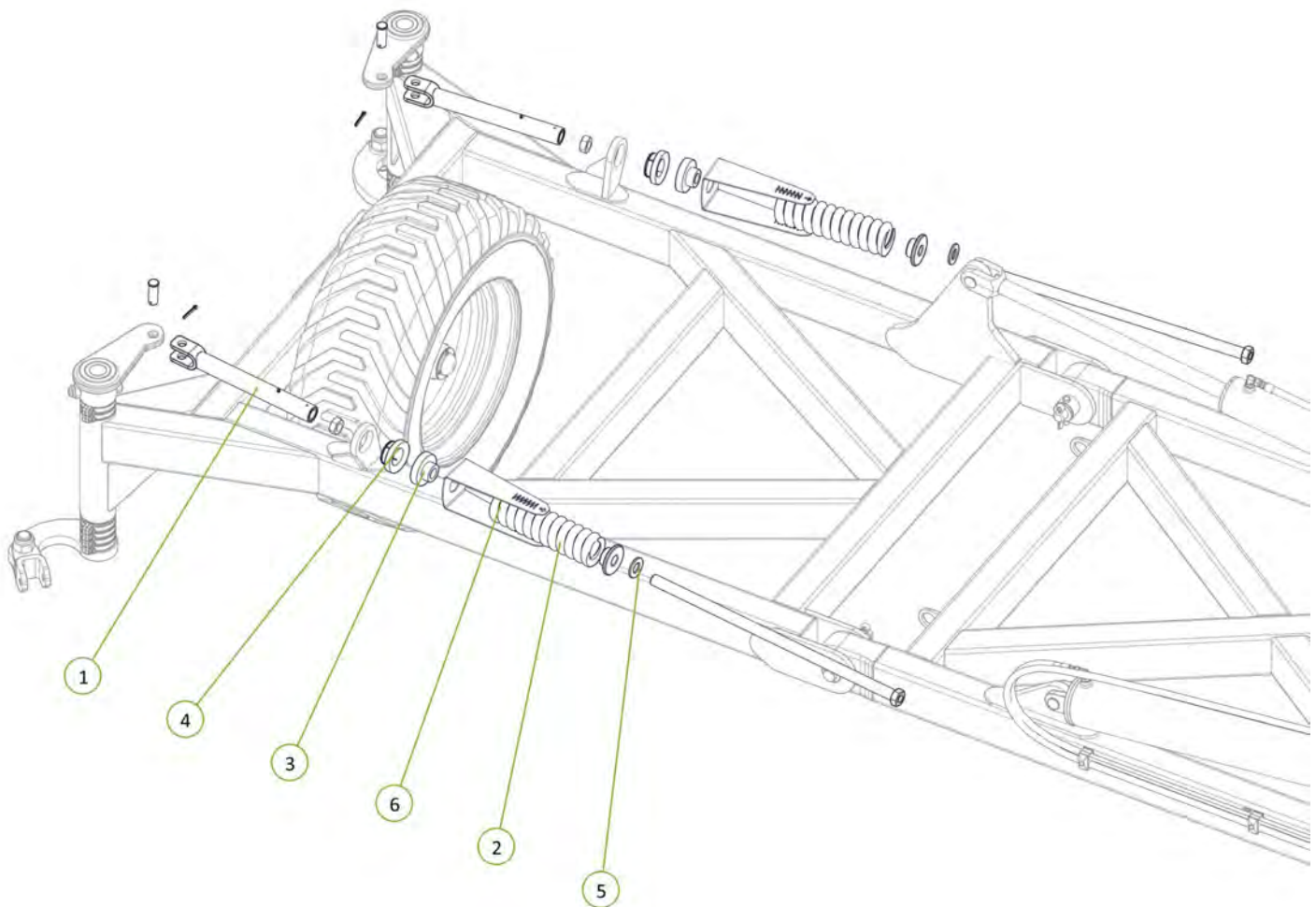

Item No.	Description	Qty	Number
1	Short Lift Arm Assembly	1	0810-167
2	Clevis Pin 25mm x 75mm	1	0801-KE0307-1
3	Cotter Pin M6 x 50mm	1	0261-PINC650
4	Washer Flat 1"	1	0232-F1

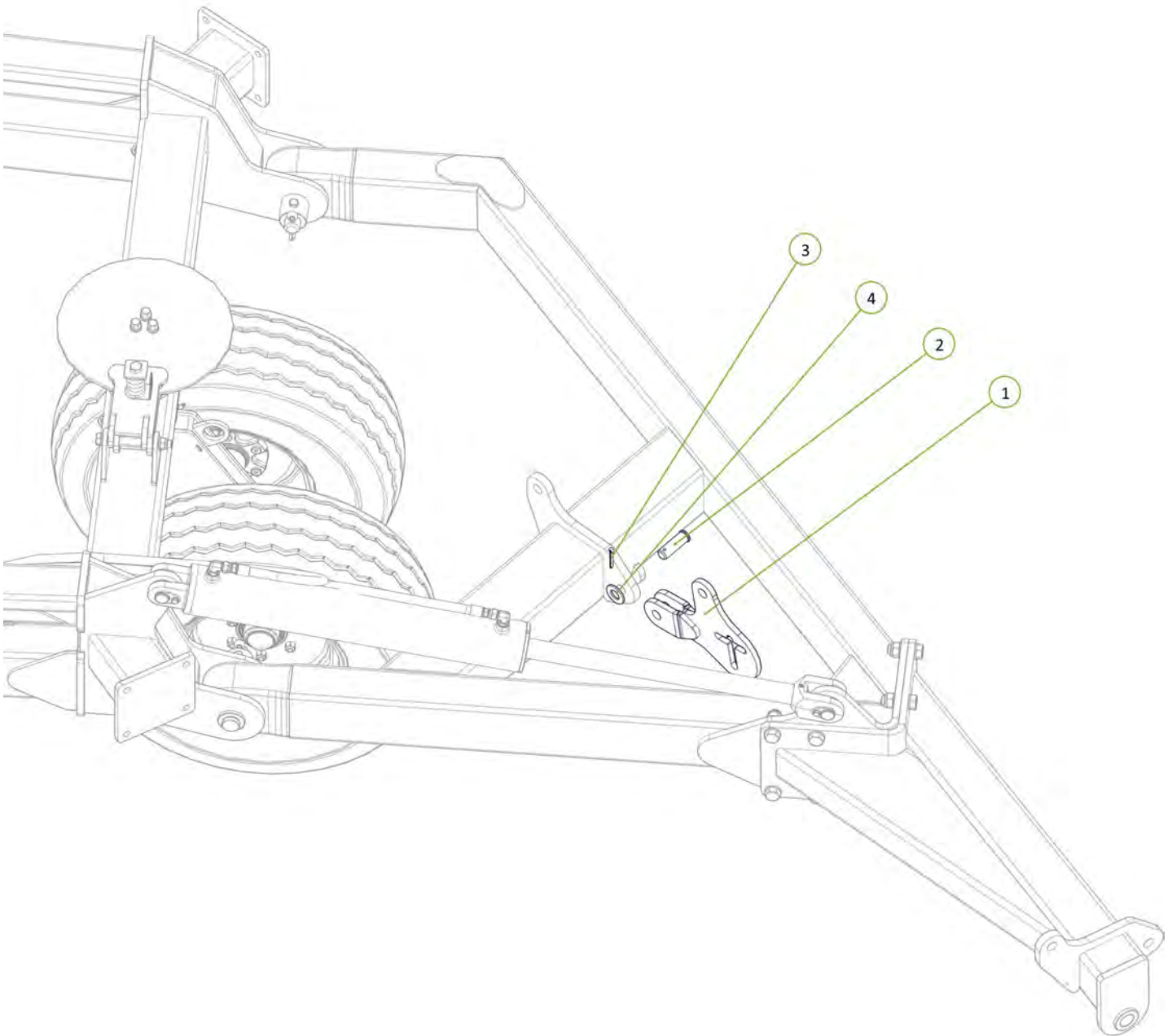

Item No.	Description	Qty	Number
1	Adjuster Mount	1	0810-161
2	Height Adjuster Rod Bolt	1	0810-163
3	Tension Adjuster Body	1	0810-164
4	ACME Lock Nut 1 1/4" - 5NA - 2G	2	0801-PCHTA-5N
5	Clevis Pin 25mm x 75mm	2	0801-KE0307-1
6	Cotter Pin M6 x 50mm	2	0261-PINC650
7	Grease Nipple 1/4" UNF	1	0181-GN1-4
8	Washer Flat 1"	2	0232-F1
9	Washer High Tensile 1 1/4"	1	0232-HT11-4

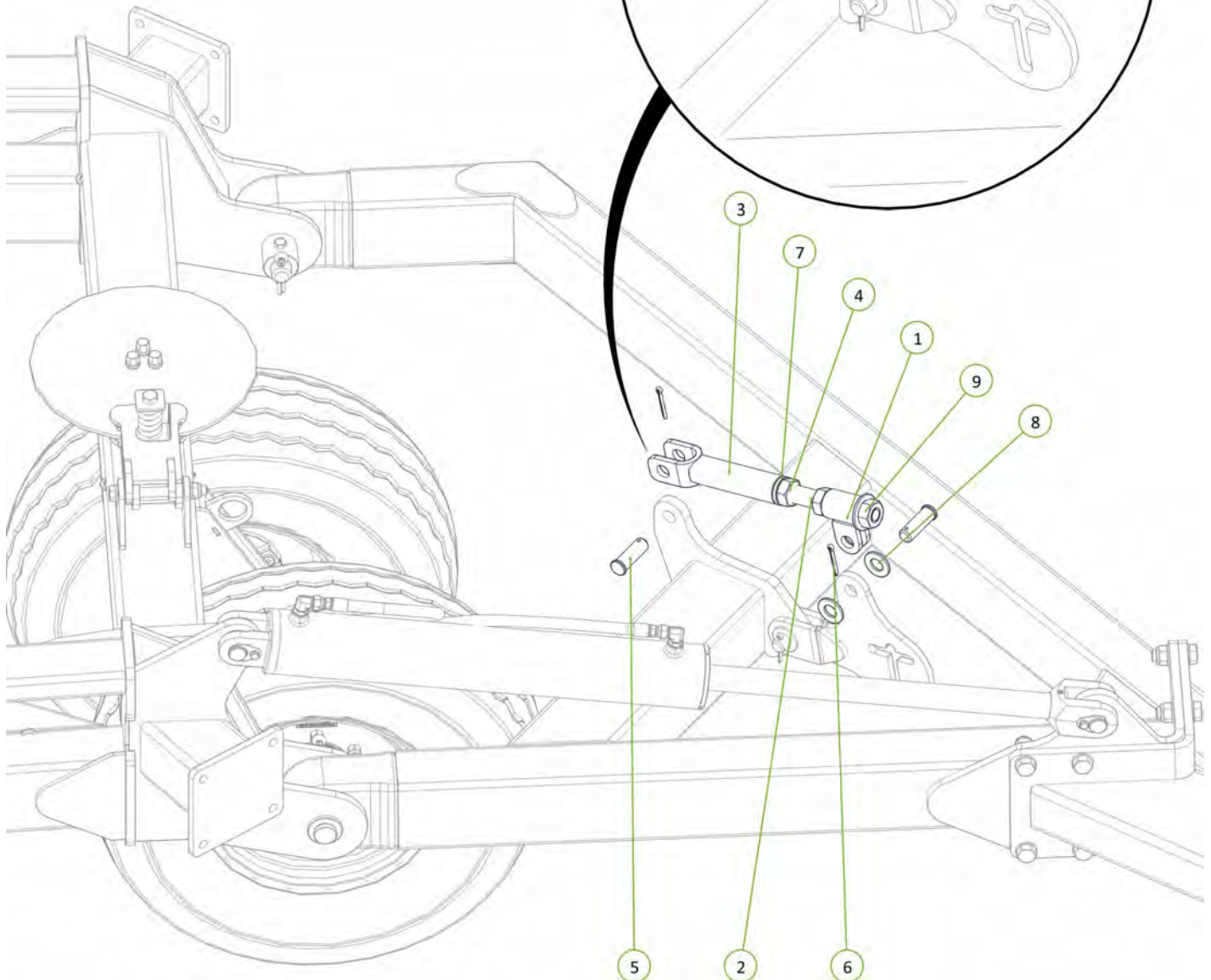
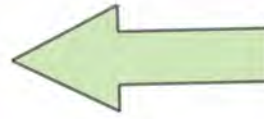

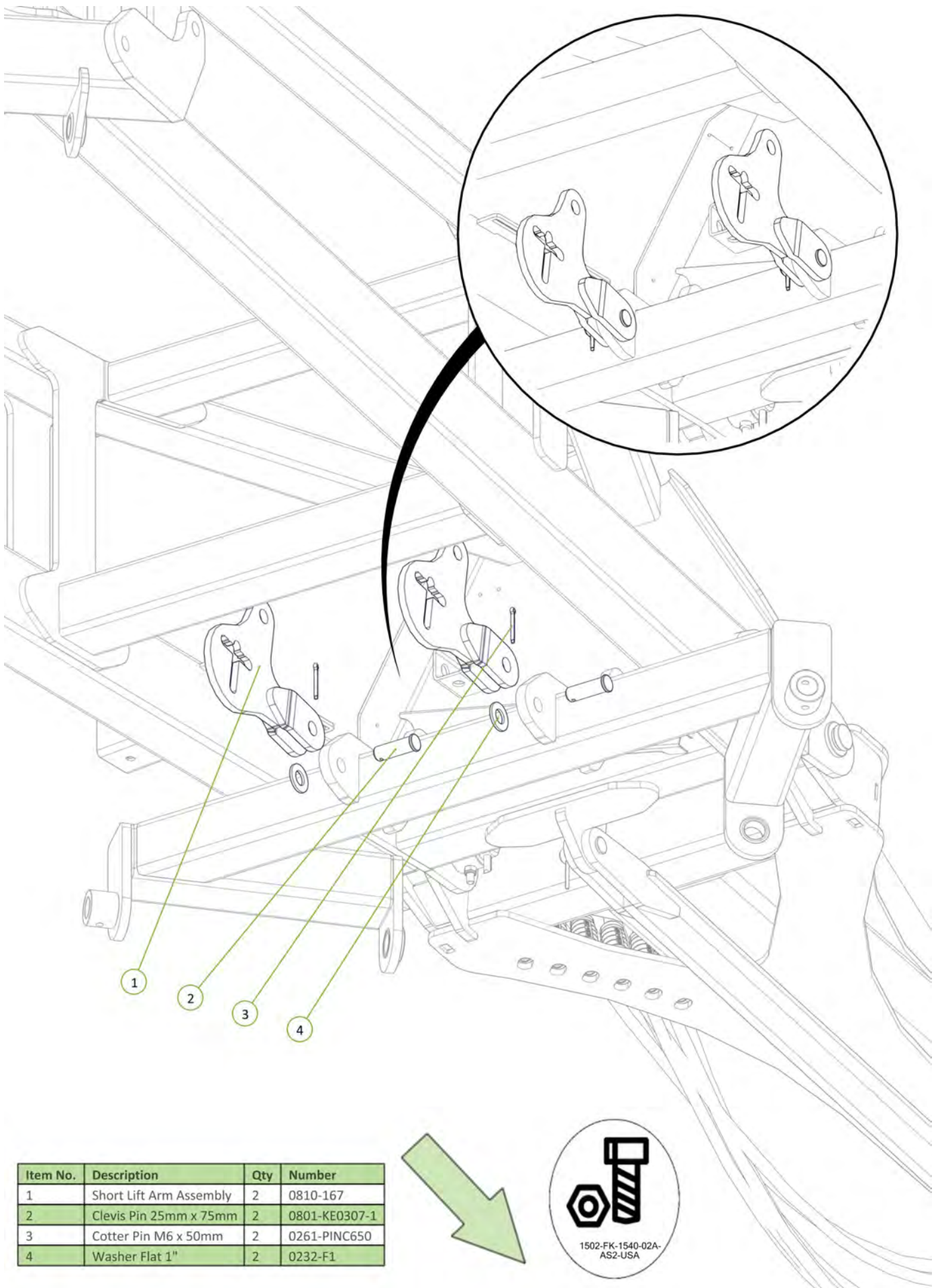

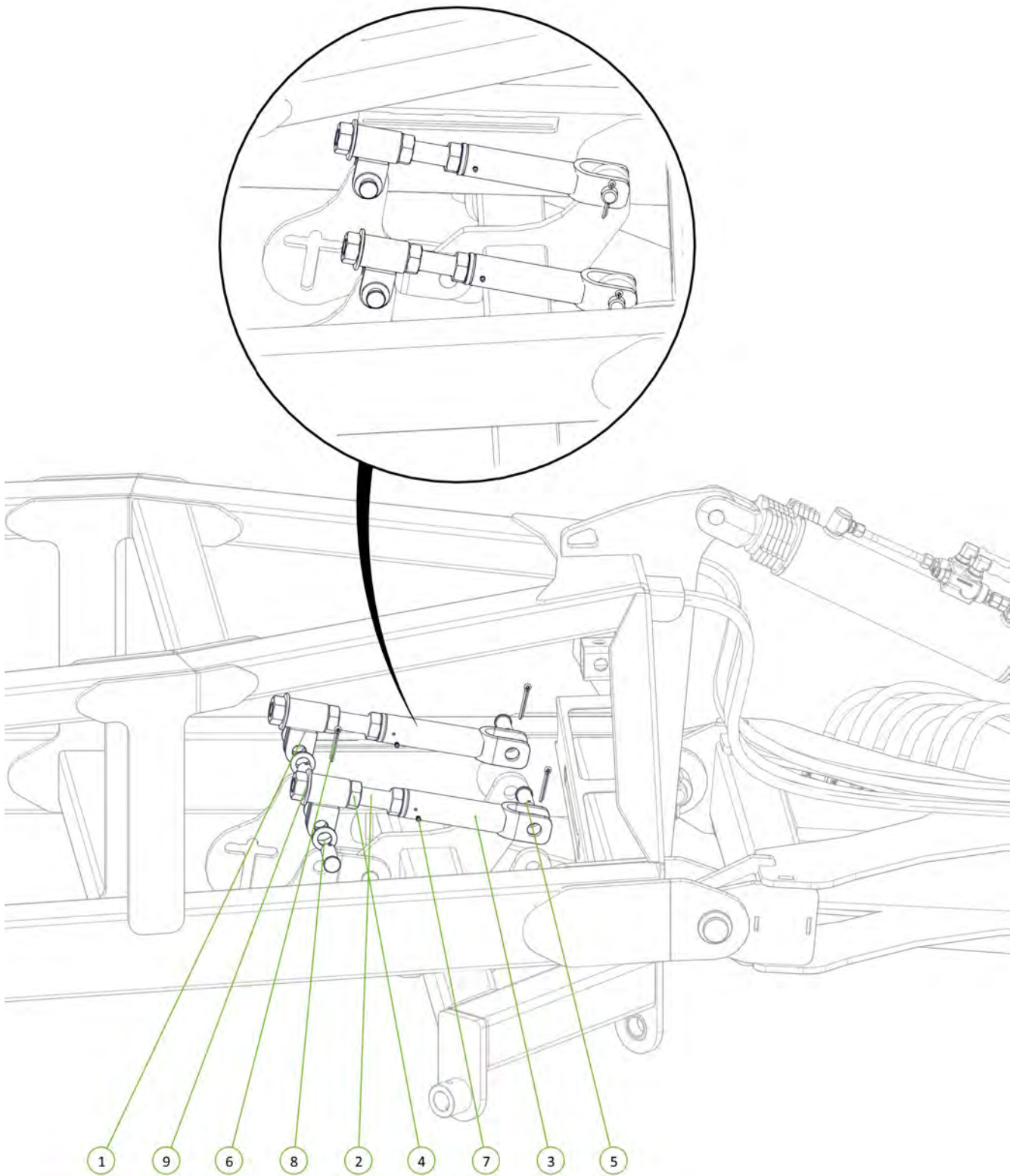

Item No.	Description	Qty	Number
1	Adjuster Mount	2	0810-161
2	Height Adjuster Rod Bolt	2	0810-163
3	Tension Adjuster Body	2	0810-164
4	ACME Lock Nut 1 1/4 - 5NA - 2G	4	0801-PCHTA-5N
5	Clevis Pin 25mm x 75mm	4	0801-KE0307-1
6	Cotter Pin M6 x 50mm	4	0261-PINC650
7	Grease Nipple 1/4" UNF	2	0181-GN1-4
8	Washer Flat M24	4	0231-F24
9	Washer High Tensile 1 1/4"	2	0232-HT11-4

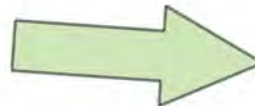

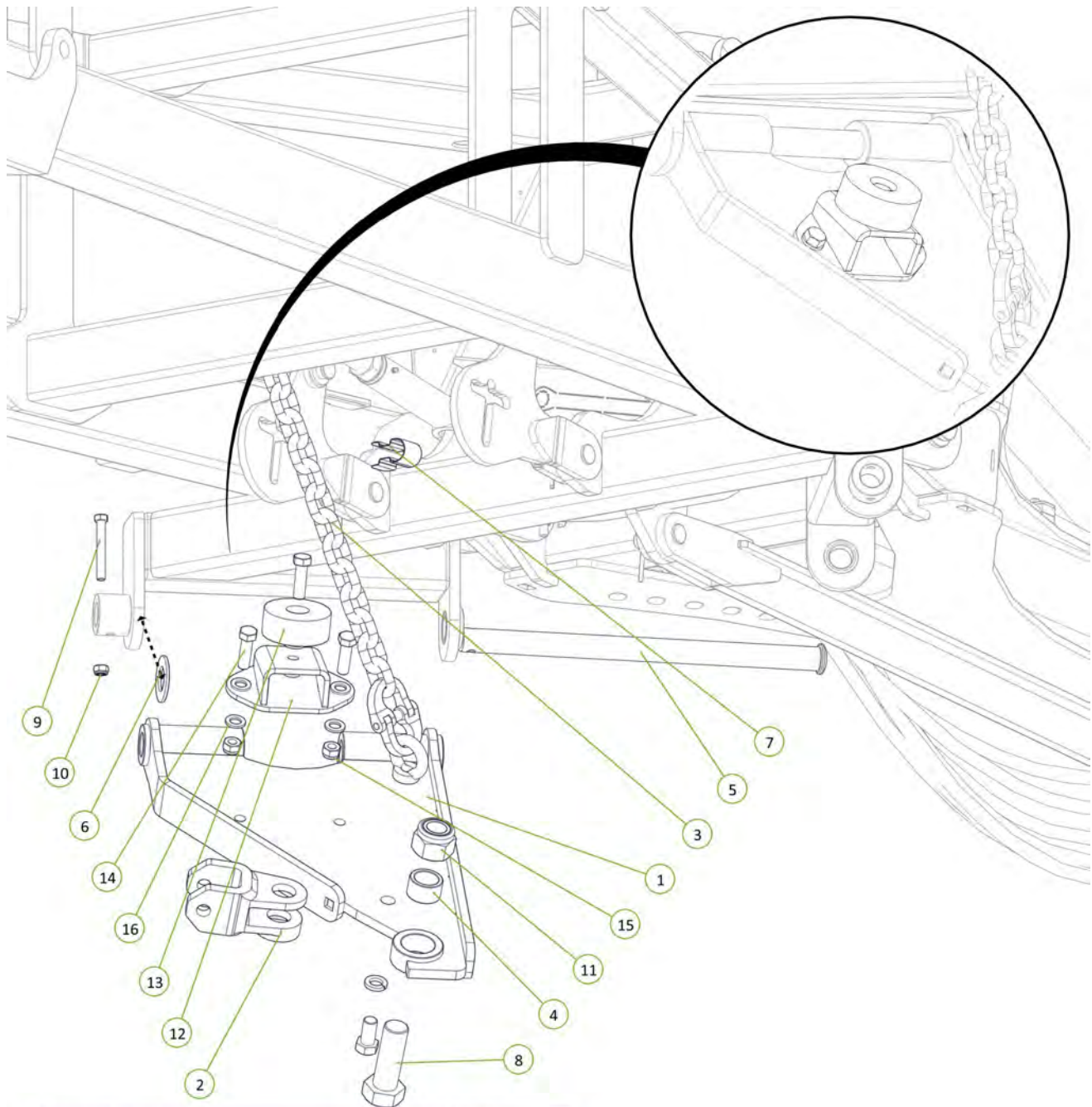

Item No.	Description	Qty	Number
1	Standard Chain Mount Plate	1	0810-20
2	Forged Clevis 21mm Bolt Hole	1	0801-FC21
3	Height Adjusting Chain Assembly 13 Link	1	0801-20MCA
4	Stainless Steel Wear Bush	1	1501-365033-SS
5	Chain Mount Pivot Pin	1	0801-10-51
6	Washer High Tensile 1 3/8"	1	0232-HT13-8
7	Height Adjustor Retaining Clip	1	0801-KE014
8	M36 Grade 8.8 ZP Bolt	1	0211-36105
9	M12 x 90 Class 8.8 ZP Bolt	1	0211-1290
10	Nyloc Nut M12	1	0221-NYL12
11	Nyloc Nut M36	1	0221-NYL36
12	Buffer Mount	1	0810-43
13	Wing Folding Buffer	1	1201-12
14	M16 x 55 Grade 8.8 ZP Bolt	3	0211-1655
15	Nyloc Nut M16	3	0221-NYL16
16	Washer Flat M16	6	0231-F16

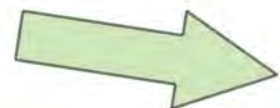

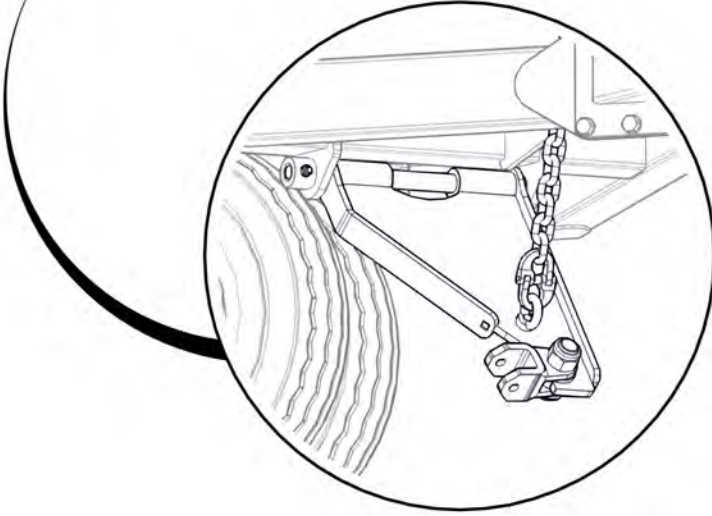
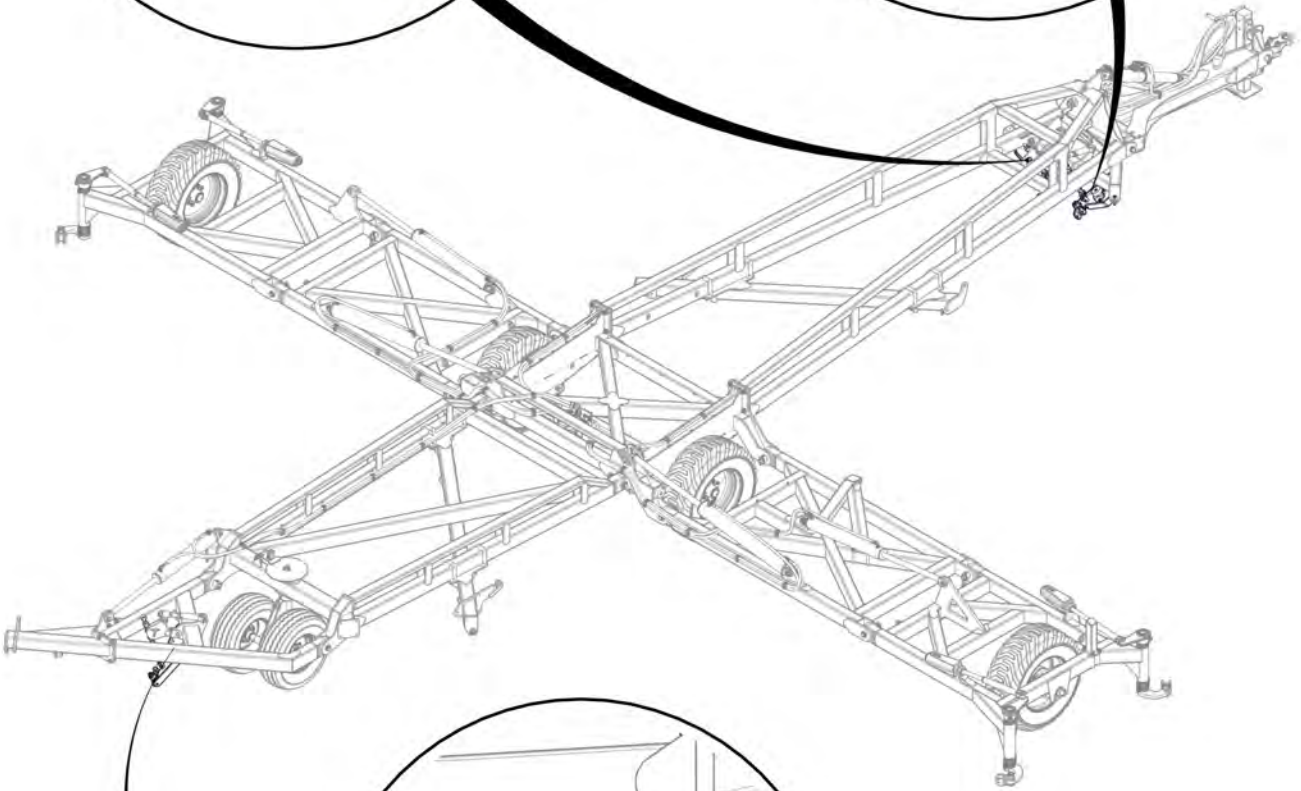
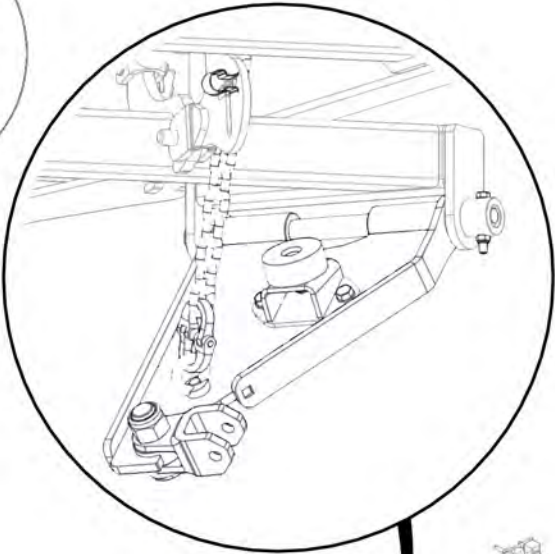
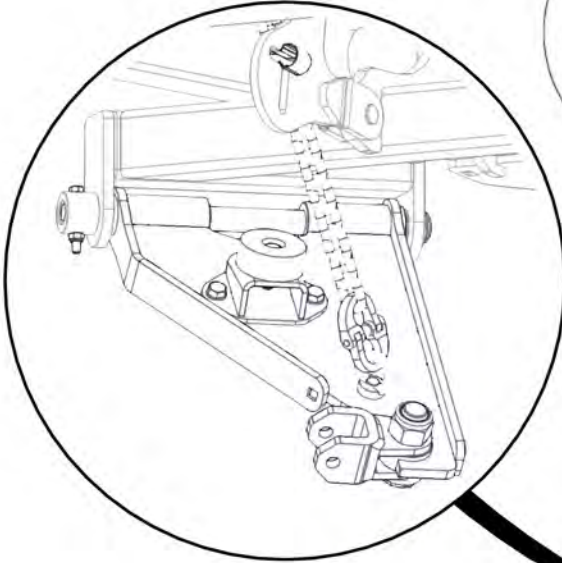

Item No.	Description	Qty	Number
1	Short Lift Arm Assembly	1	0810-167
2	Clevis Pin 25mm x 75mm	1	0801-KE0307-1
3	Cotter Pin M6 x 50mm	1	0261-PINC650
4	Washer Flat 1"	1	0232-F1

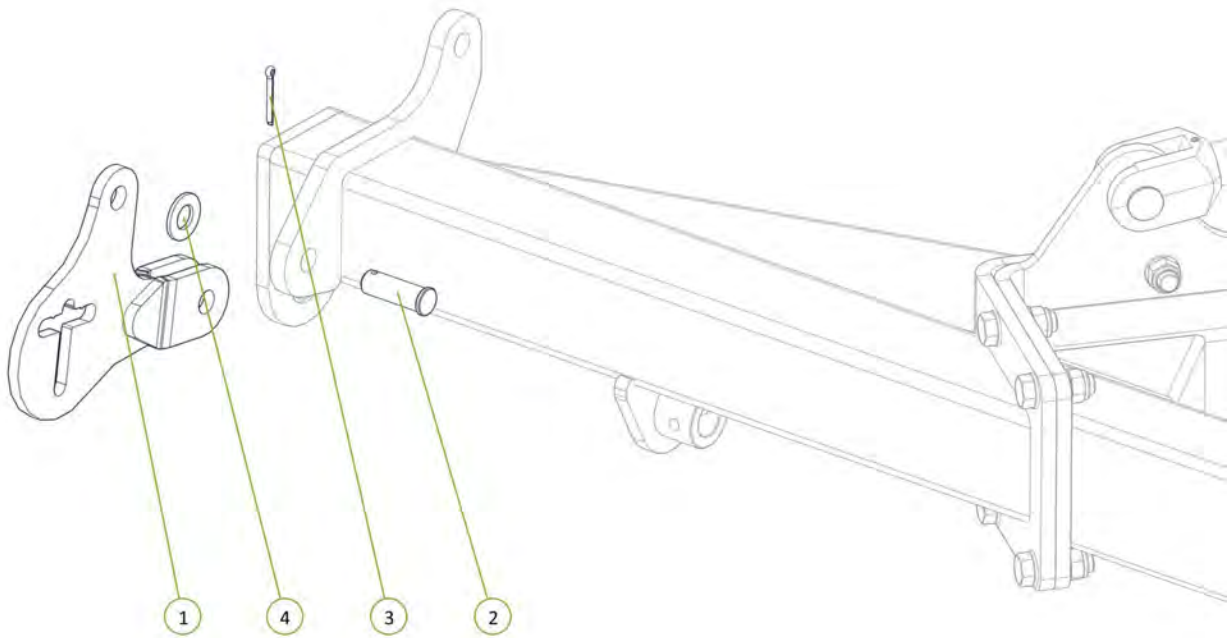

Item No.	Description	Qty	Number
1	Adjuster Mount	1	0810-161
2	Height Adjuster Rod Bolt	1	0810-163
3	Tension Adjuster Body	1	0810-164
4	ACME Lock Nut 1 1/4 - 5NA - 2G	2	0801-PCHTA-5N
5	Clevis Pin 25mm x 75mm	2	0801-KE0307-1
6	Cotter Pin M6 x 50mm	2	0261-PINC650
7	Grease Nipple 1/4" UNF	1	0181-GN1-4
8	Washer Flat 1"	2	0232-F1
9	Washer High Tensile 1 1/4"	1	0232-HT11-4

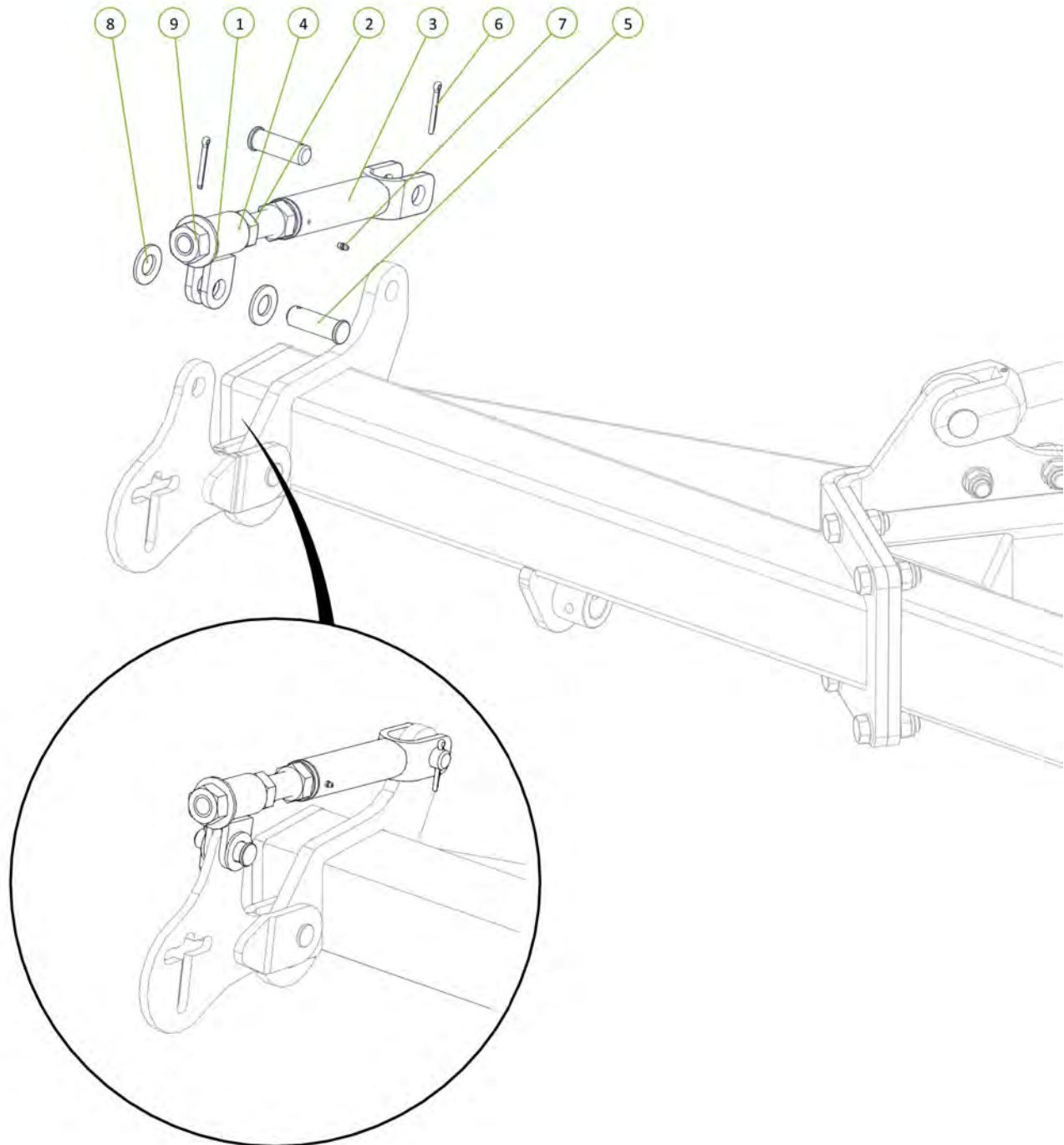

Item No.	Description	Qty	Number
1	Extended Chain Mount Plate	1	0810-69
2	Forged Clevis 21mm Bolt Hole	1	0801-FC21
3	Height Adjusting Chain Assembly 13 Link	1	0801-20MCA
4	Stainless Steel Wear Bush	1	1501-365033-SS
5	Chain Mount Pivot Pin	1	0801-10-51
6	M36 x 105 grade 8.8 zp Bolt	1	0211-36105
7	Nyloc Nut M36	1	0221-NYL36
8	Washer High Tensile 1 3/8"	1	0232-HT13-8
9	Height Adjustor Retaining Clip	1	0801-KE014
10	M12 x 90 Class 8.8 ZP Bolt	1	0211-1290
11	Nyloc Nut M12	1	0221-NYL12

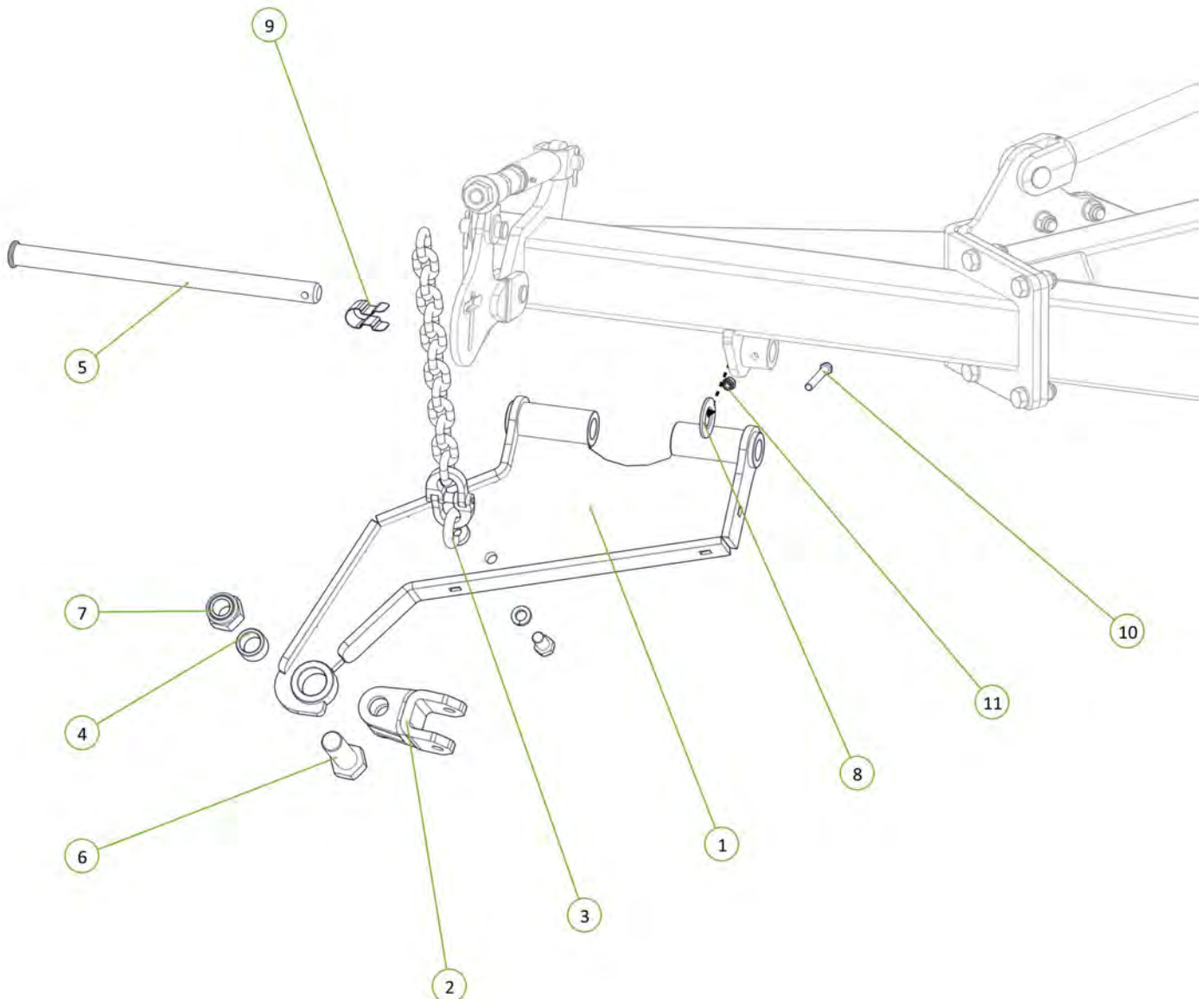

1502-FK-1510-29-
12A-2-AS2-USA

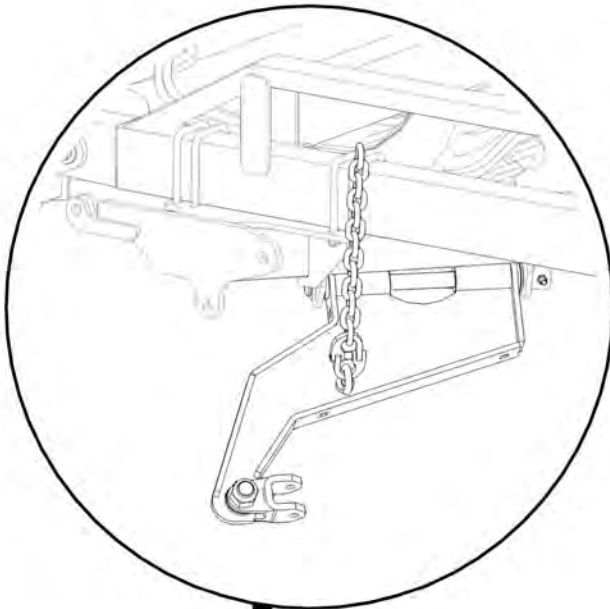

1502-FK-1510-28-
12A-AS2-USA

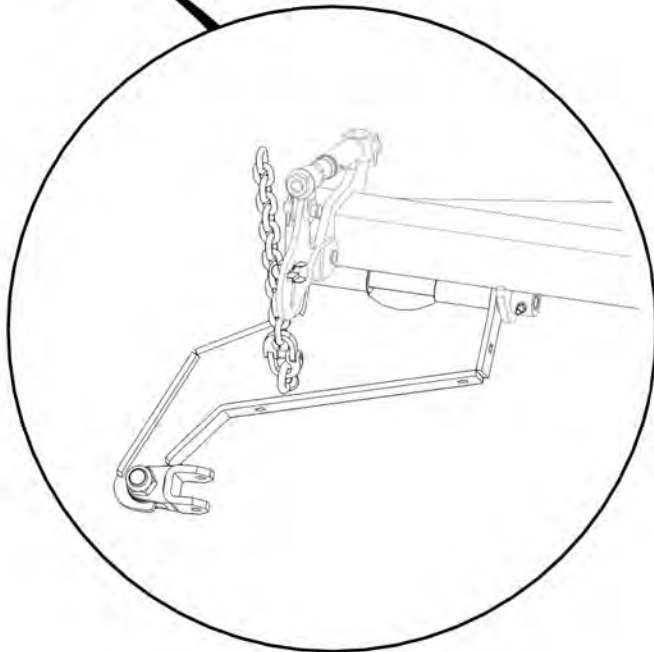
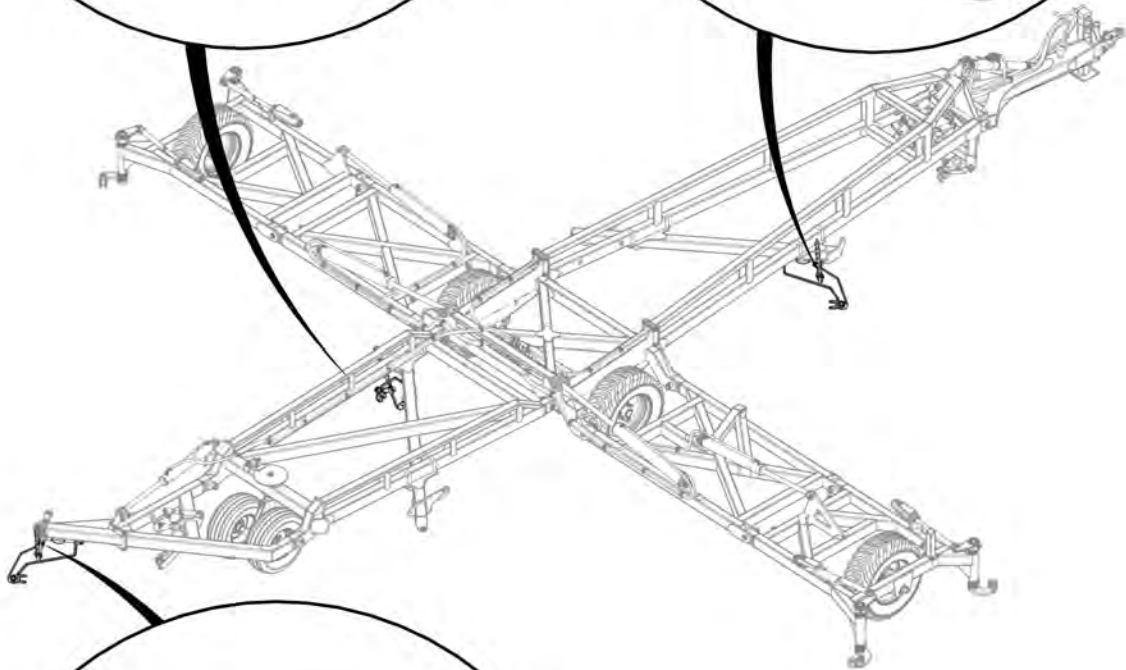
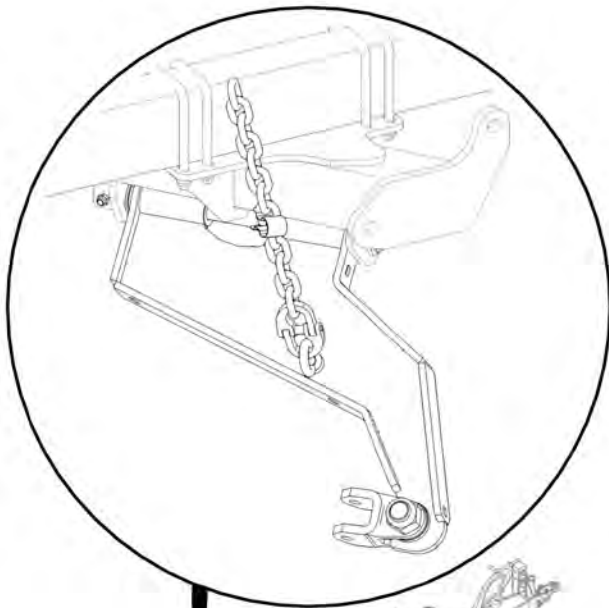

Item No.	Description	Qty	Number
1	Tension Box	1	0810-57
2	Module Tension Rod Assembly	1	0810-105A
3	Heavy Duty Coil Spring 24mm	1	0801-K2455350
4	Rigid Spring Locator	1	0801-10-S2L
5	Washer High Tensile 1 1/4"	1	0232-HT11-4
6	Height Adjusting Chain Assembly 13 Link	1	0801-20MCA
7	Washer Flat 1"	1	0232-F1

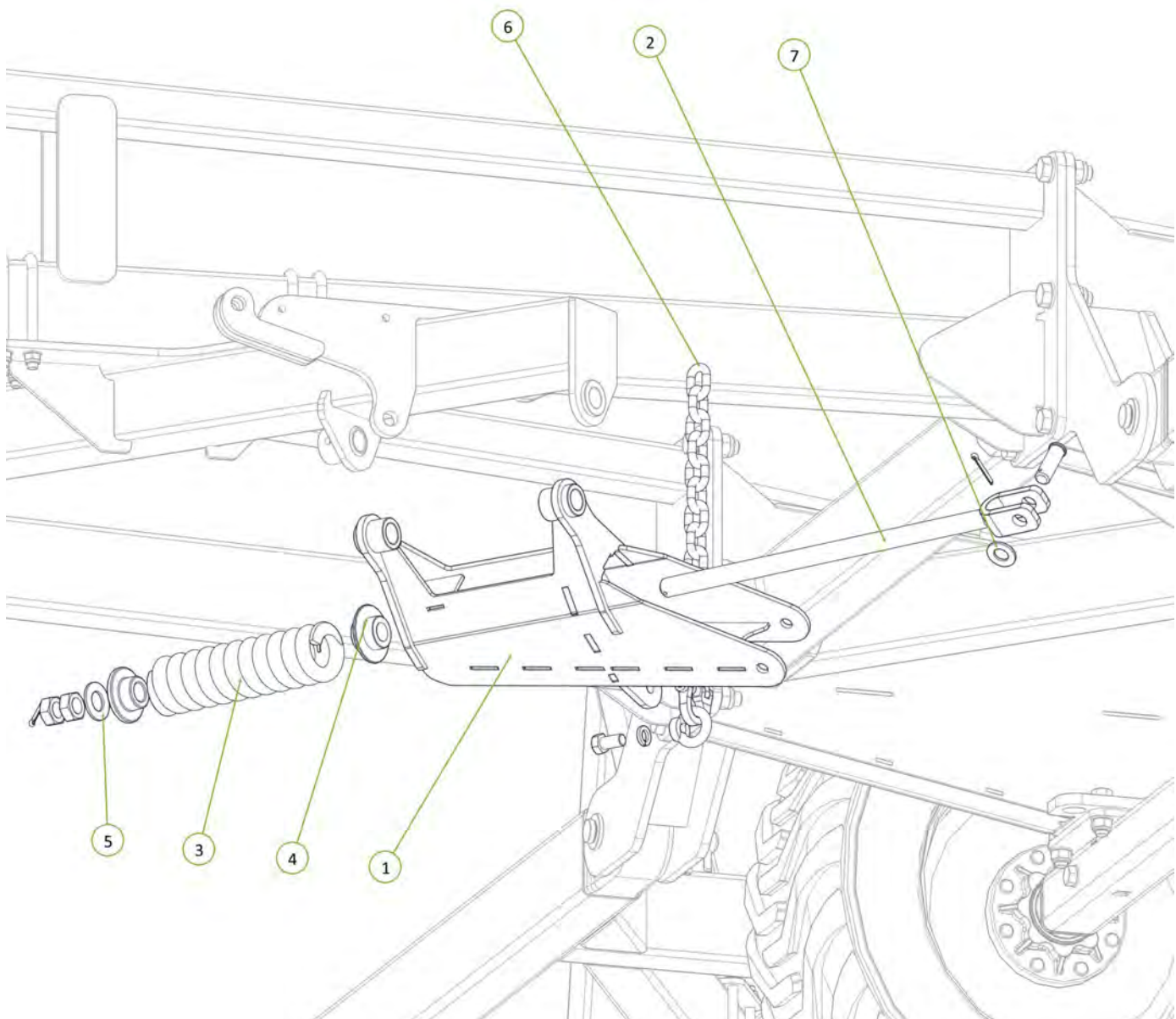

Item No.	Description	Qty	Number
1	Module Tension Arm No Clevis	1	0810-104F
2	Module Pivot Arm Bush	1	0801-10-110
3	Forged Clevis 21mm Bolt Hole	1	0801-FC21
4	M36 x 105 Class 8.8 ZP Bolt	1	0211-36105
5	M20 x 160 Grade 8.8 ZP Bolt	1	0211-20160
6	Nyloc Nut M20	1	0221-NYL20
7	Nyloc Nut M36	1	0221-NYL36
8	Wear Bush	1	1501-365033-SS
9	Washer Flat M20	2	0231-F20
10	35 ID x 50mm DU Bush	2	0113-MB3550DU

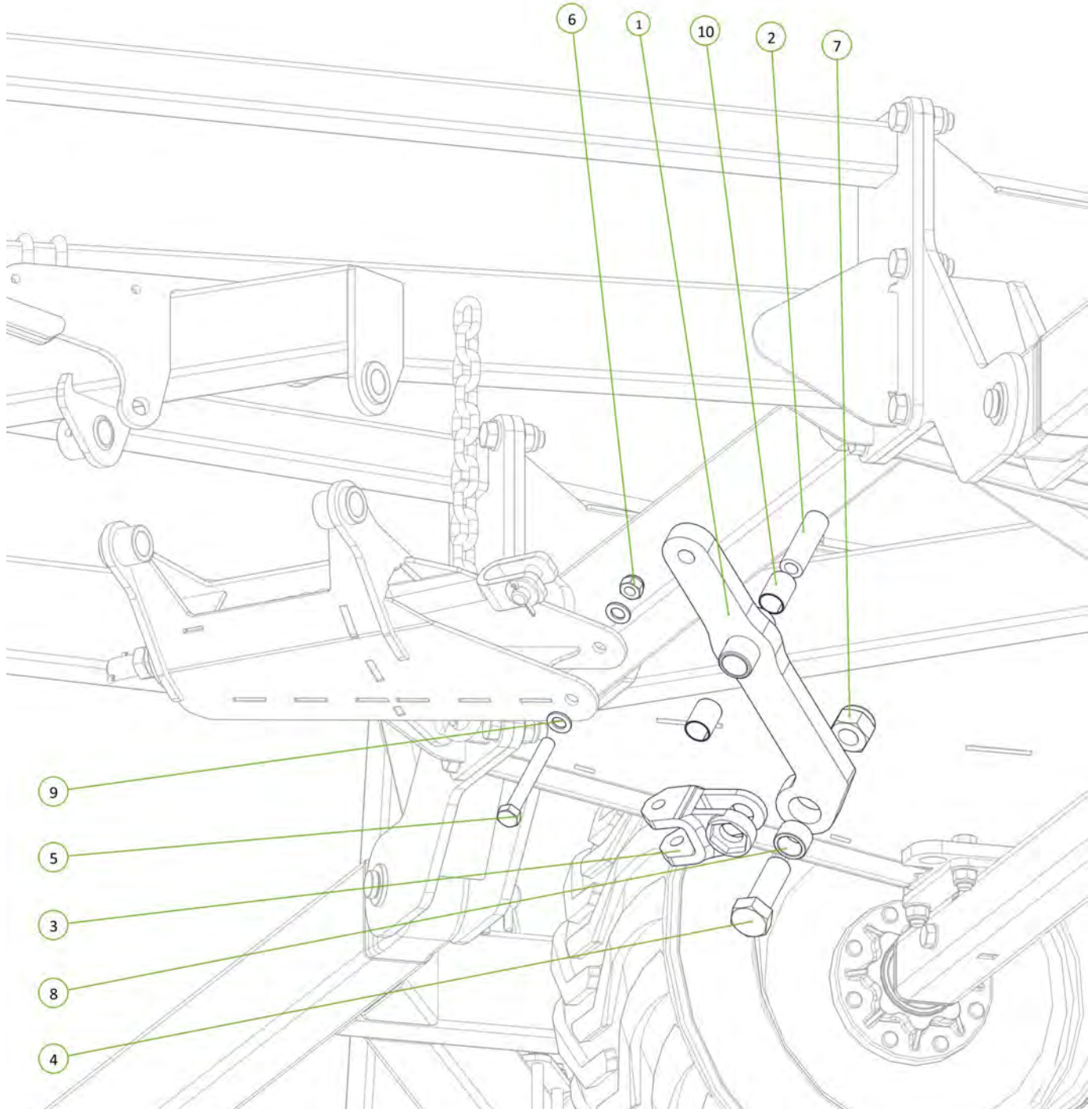

Item No.	Description	Qty	Number
1	Chain Mount Pivot Pin	1	0801-10-51
2	Washer High Tensile 1 3/8"	1	0232-HT13-8
3	M12 x 90 Class 8.8 ZP Bolt	1	0211-1290
4	Nyloc Nut M12	1	0221-NYL12

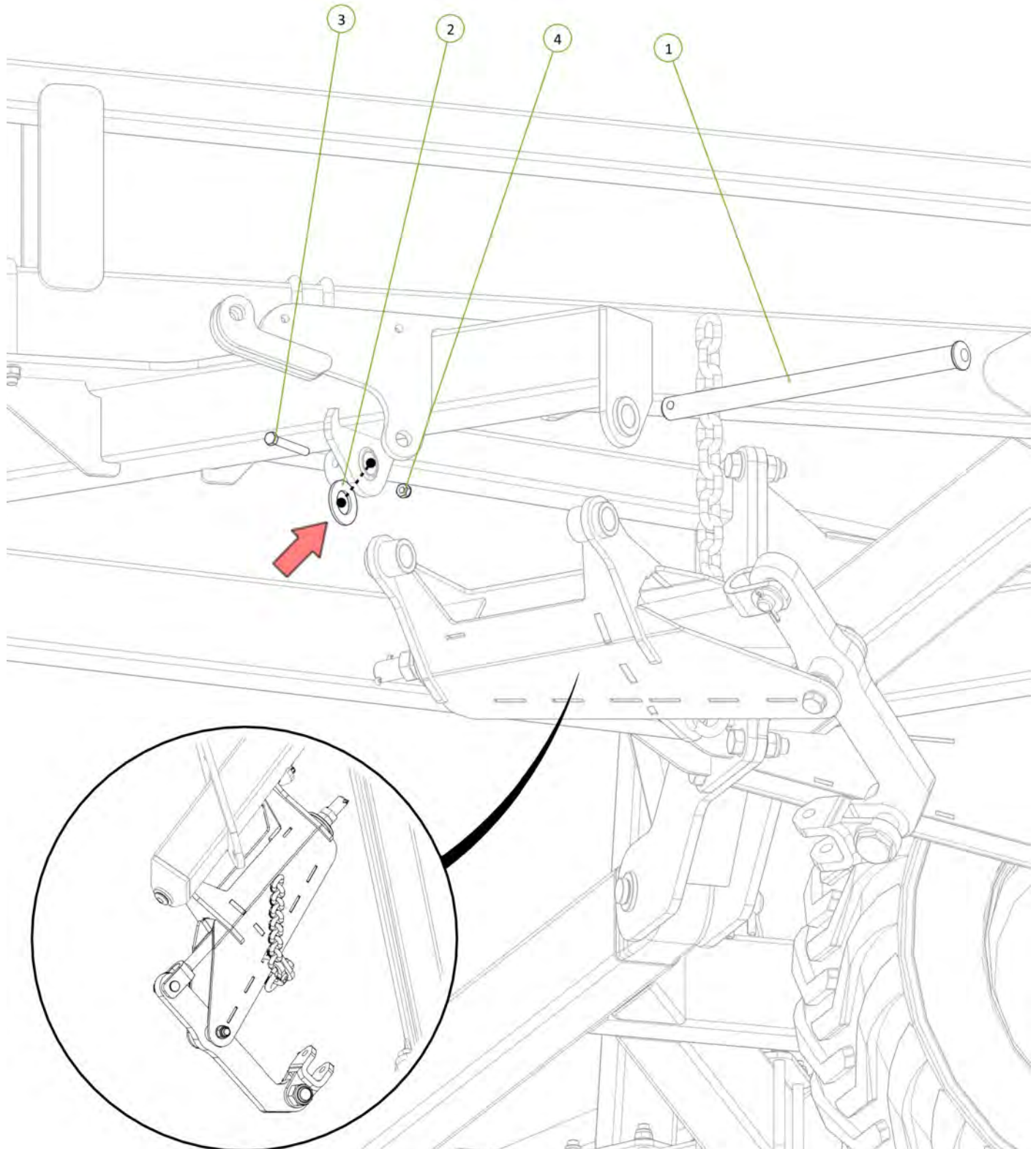

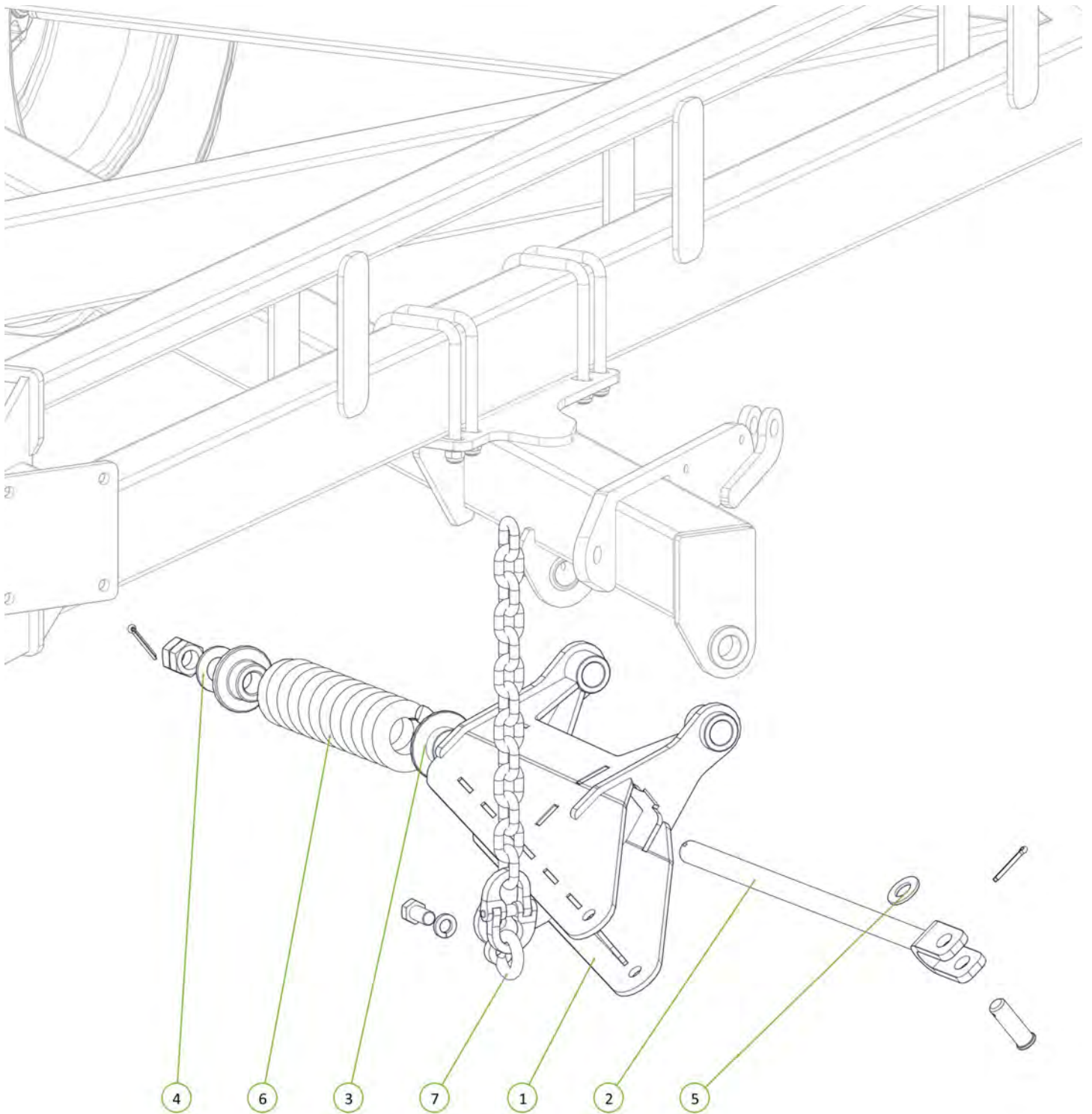

Item No.	Description	Qty	Number
1	Tension Box	1	0810-57
2	Module Tension Rod Assembly	1	0810-105A
3	Rigid Spring Locator	1	0801-10-S2L
4	Washer High Tensile 1 1/4"	1	0232-HT11-4
5	Washer Flat 1"	1	0232-F1
6	Heavy Duty Coil Spring 24mm	1	0801-K2455350
7	Height Adjusting Chain Assembly 13 Link	1	0801-20MCA



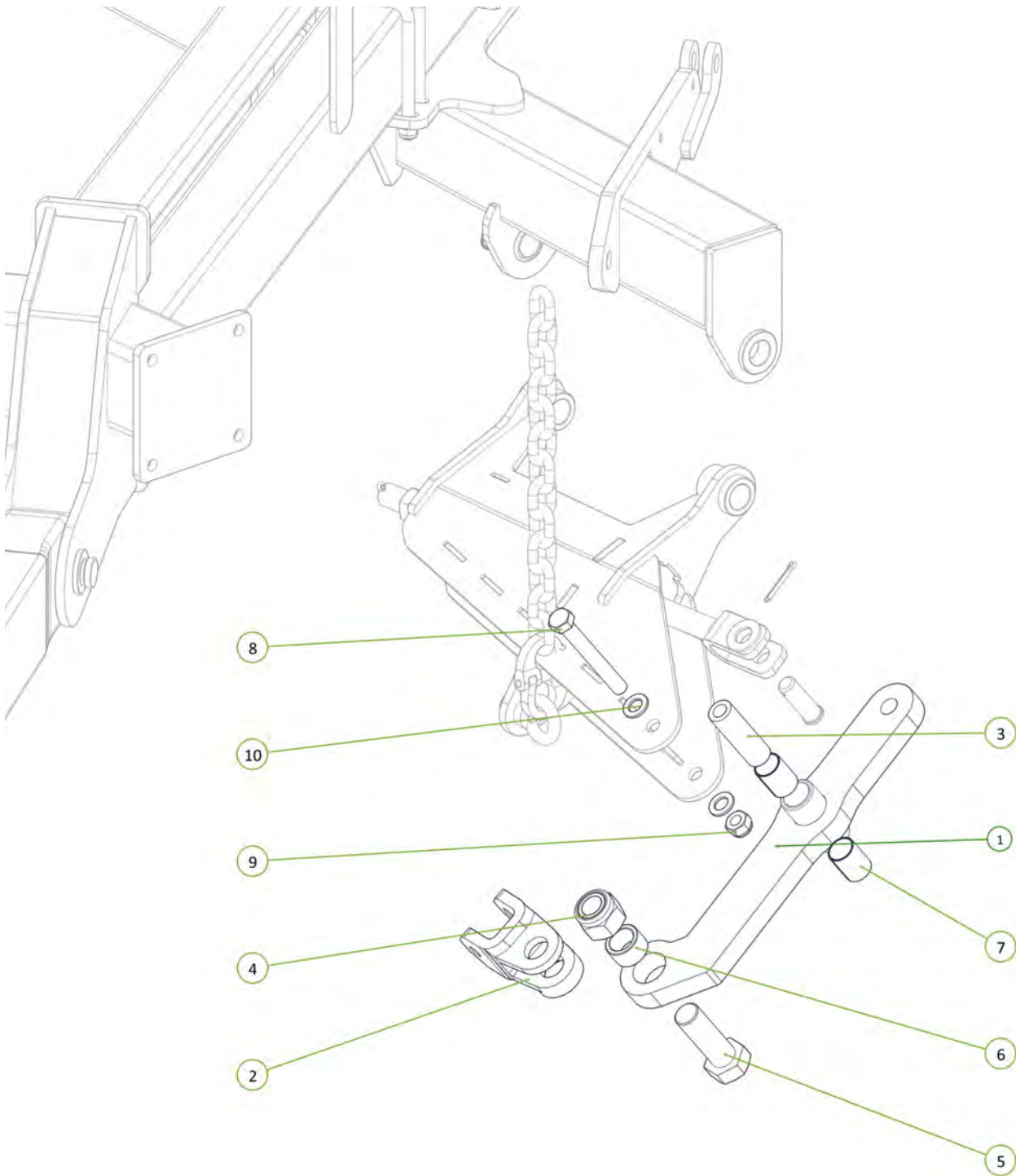

Item No.	Description	Qty	Number
1	Module Tension Arm No Clevis	1	0810-104F
2	Forged Clevis 21mm Bolt Hole	1	0801-FC21
3	Module Pivot Arm Bush	1	0801-10-110
4	Nyloc Nut M36	1	0221-NYL36
5	M36 x 105 Class 8.8 ZP Bolt	1	0211-36105
6	Wear Bush	1	1501-365033-SS
7	35 ID x 50mm DU Bush	2	0113-MB3550DU
8	M20 x 160 Grade 8.8 ZP Bolt	1	0211-20160
9	Nyloc Nut M20	1	0221-NYL20
10	Washer Flat M20	2	0231-F20



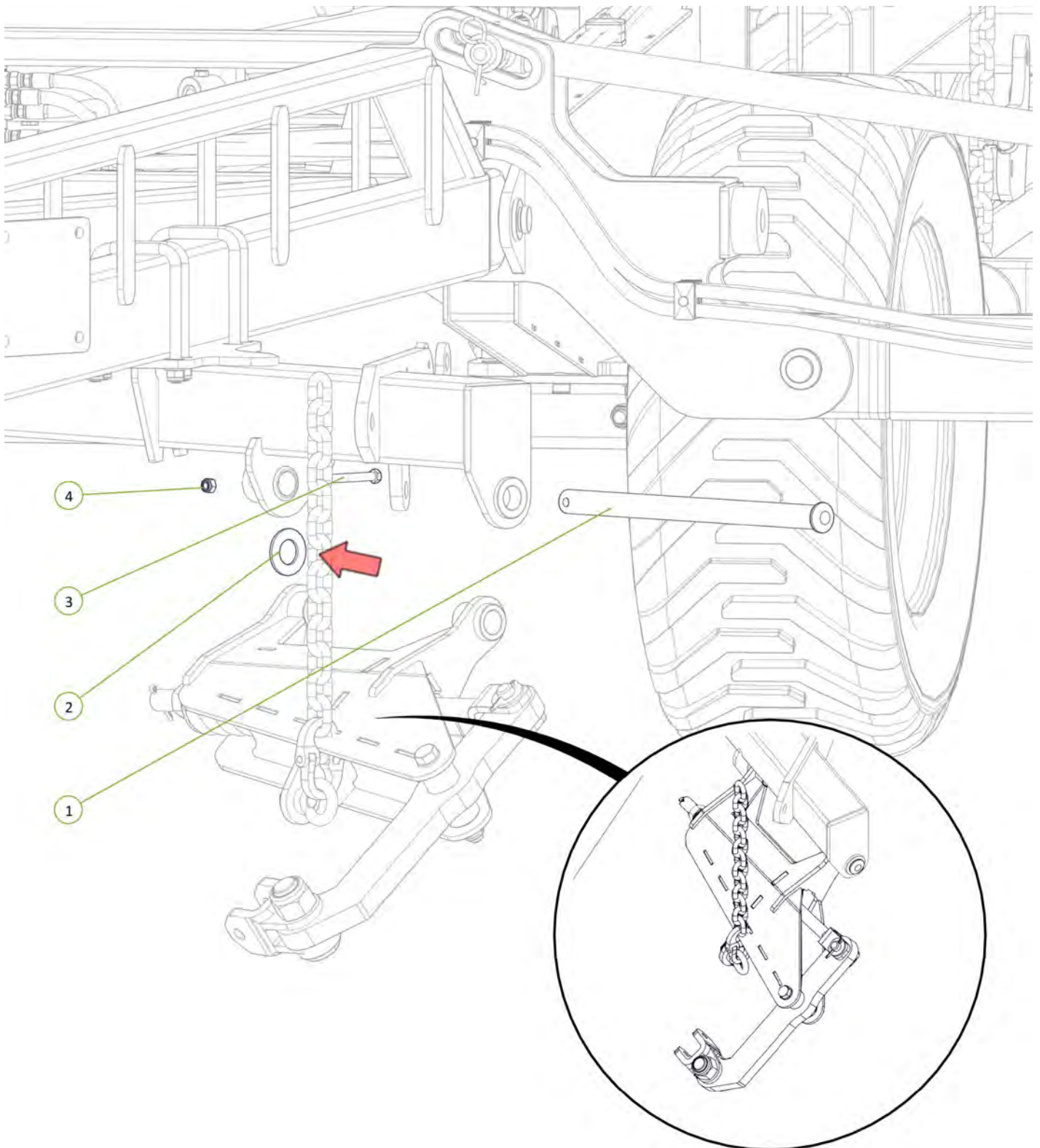

Item No.	Description	Qty	Number
1	Chain Mount Pivot Pin	1	0801-10-51
2	Washer High Tensile 1 3/8"	1	0232-HT13-8
3	M12 x 90 Class 10.9 ZP Bolt	1	0211-1290
4	Nyloc Nut M12	1	0221-NYL12



Item No.	Description	Qty	Number
1	Compact Module Lift Arm	1	0810-51
2	Clevis Pin 25mm x 75mm	1	0801-KE0307-1
3	Height Adjustor Retaining Clip	1	0801-KE014
4	Washer Flat 1"	1	0232-F1
5	Cotter Pin M6 x 50mm	1	0261-PINC650

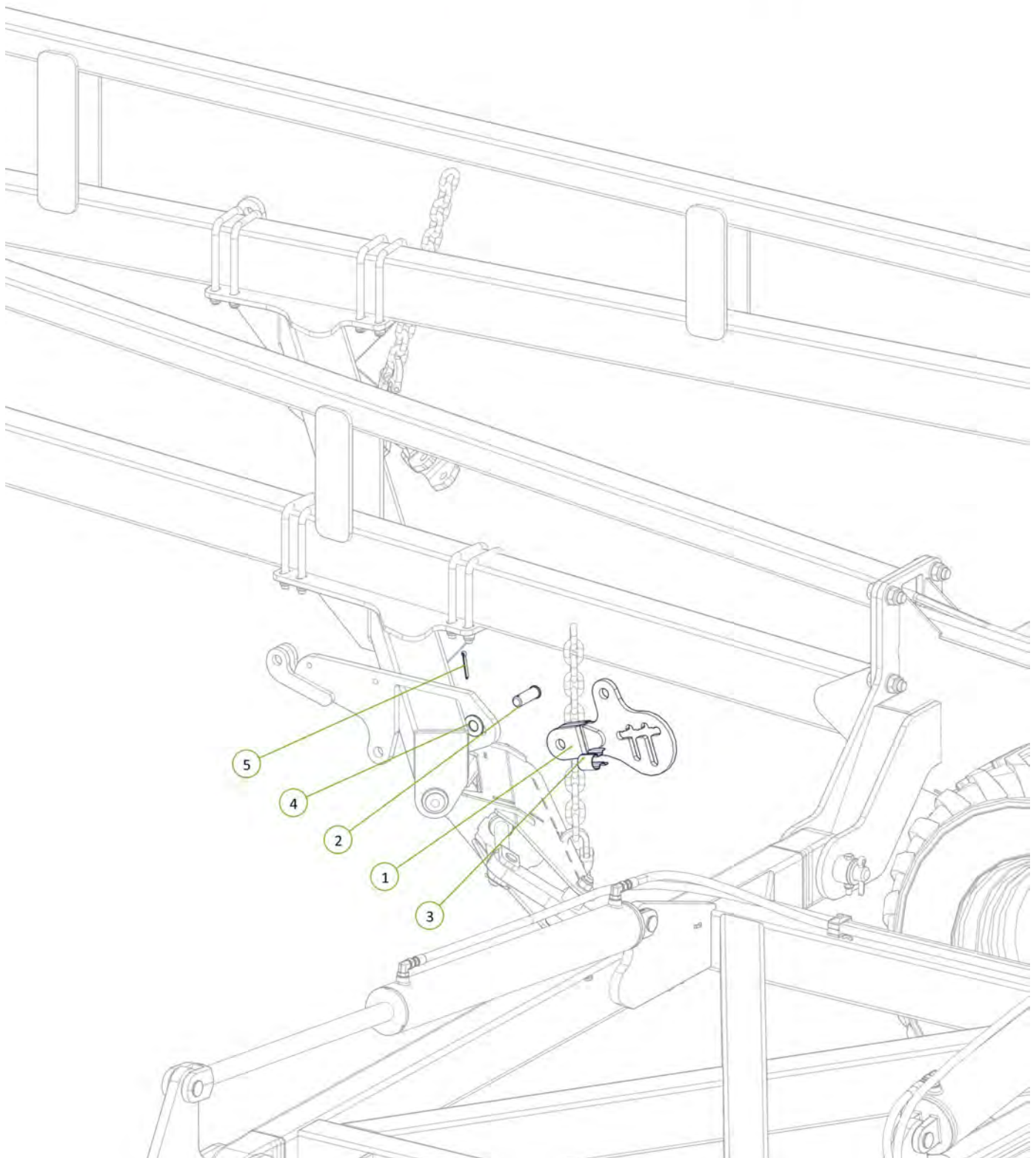

Item No.	Description	Qty	Number
1	Adjustor Linkage	1	0810-88
2	Clevis Pin 25mm x 75mm	1	0801-KE0307-1
3	Cotter Pin M6 x 50mm	1	0261-PINC650
4	Washer Flat 1"	1	0232-F1

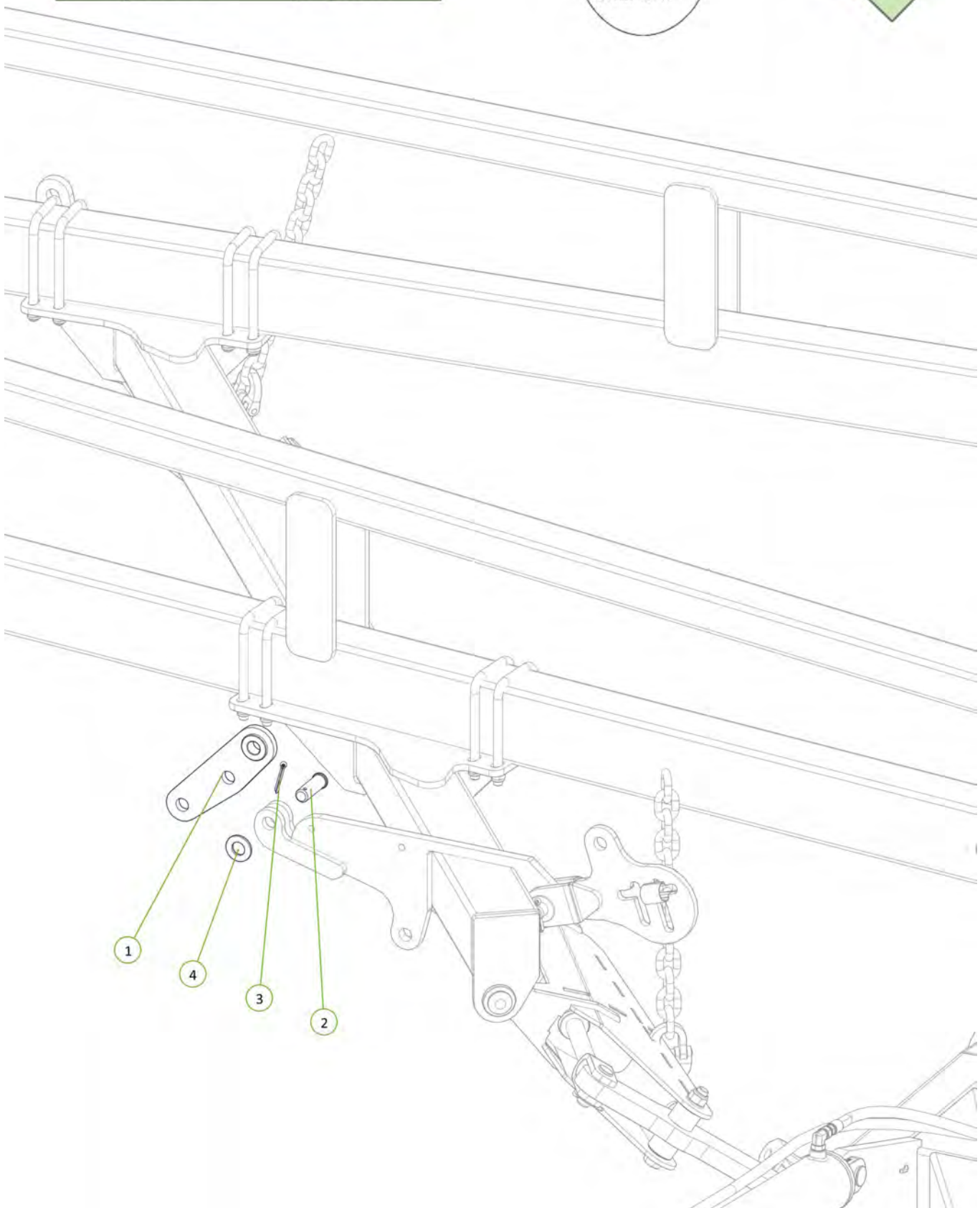

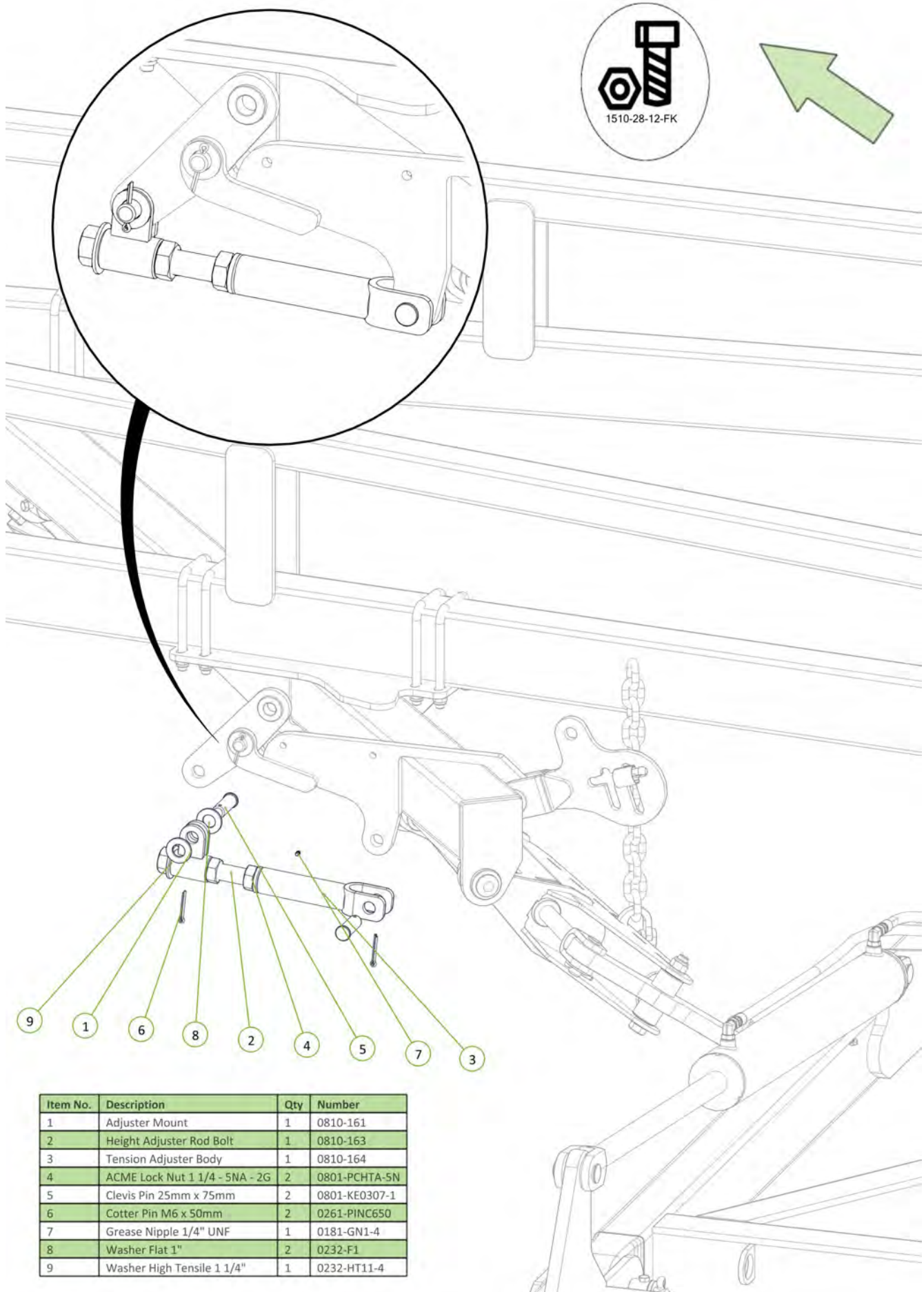

Item No.	Description	Qty	Number
1	2.5" Bore x 6" Stroke 1.5" Rod Side Port Cylinder	1	0311-256SP

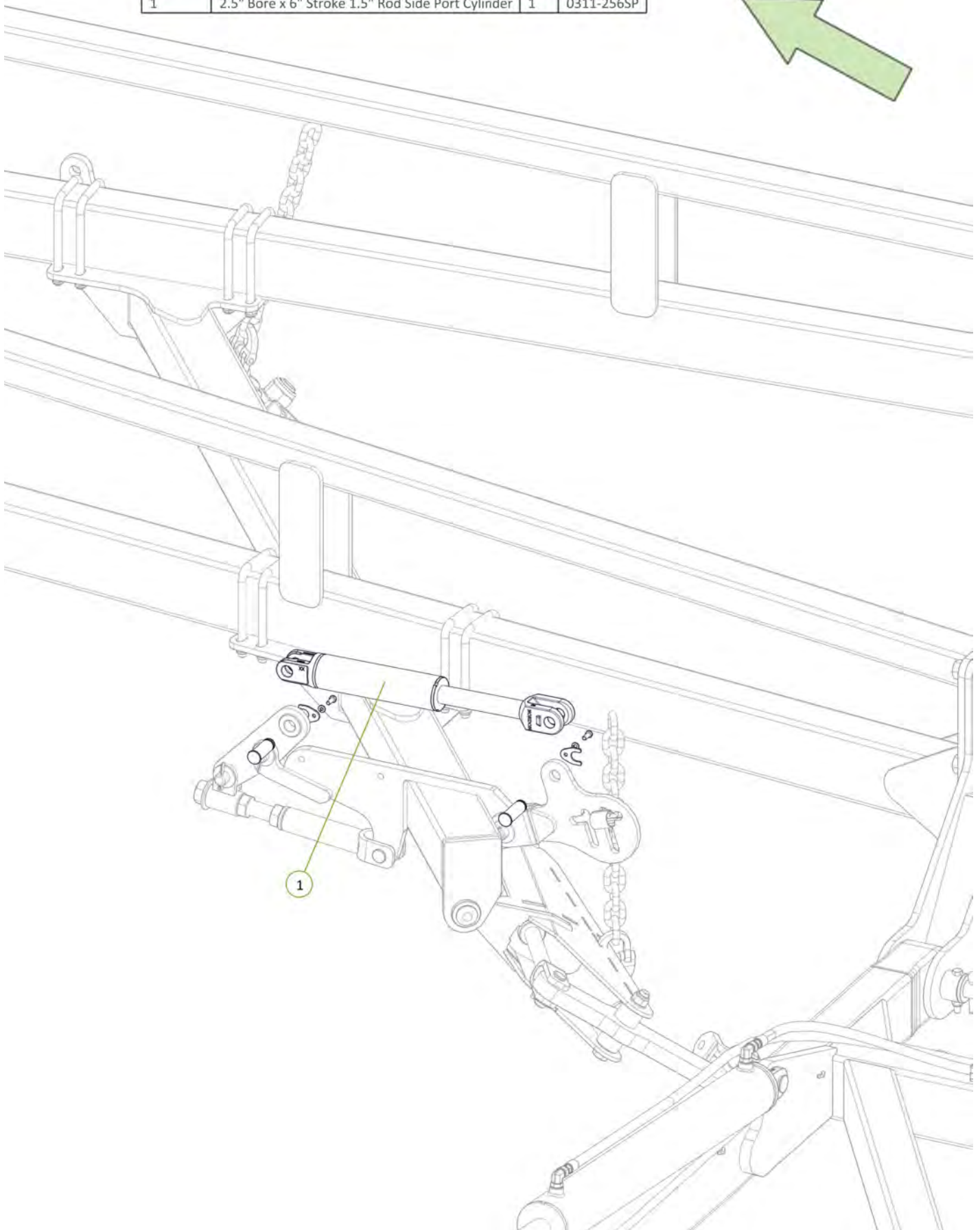

Item No.	Description	Qty	Number
1	3/4" JIC Male 3/4" UN O Ring Male 45° Elbow	2	0323-S88-1212

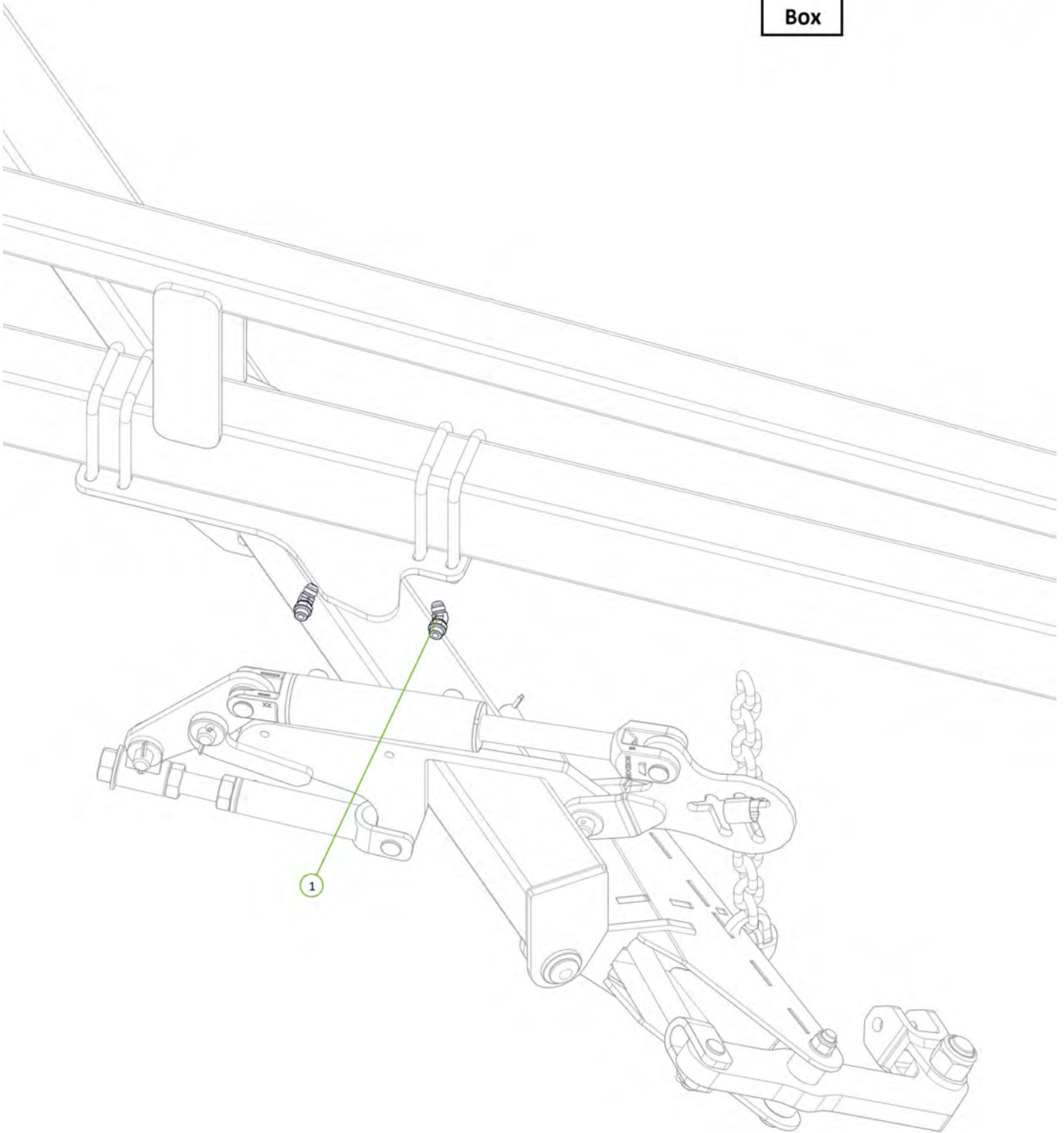
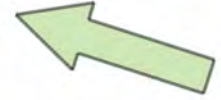
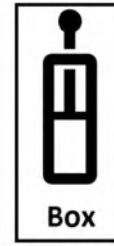

Item No.	Description	Qty	Number
1	ME3 to Front Cylinder Extend Port	1	H12-07
2	MR3 to Front Module Retract Port	1	H12-08

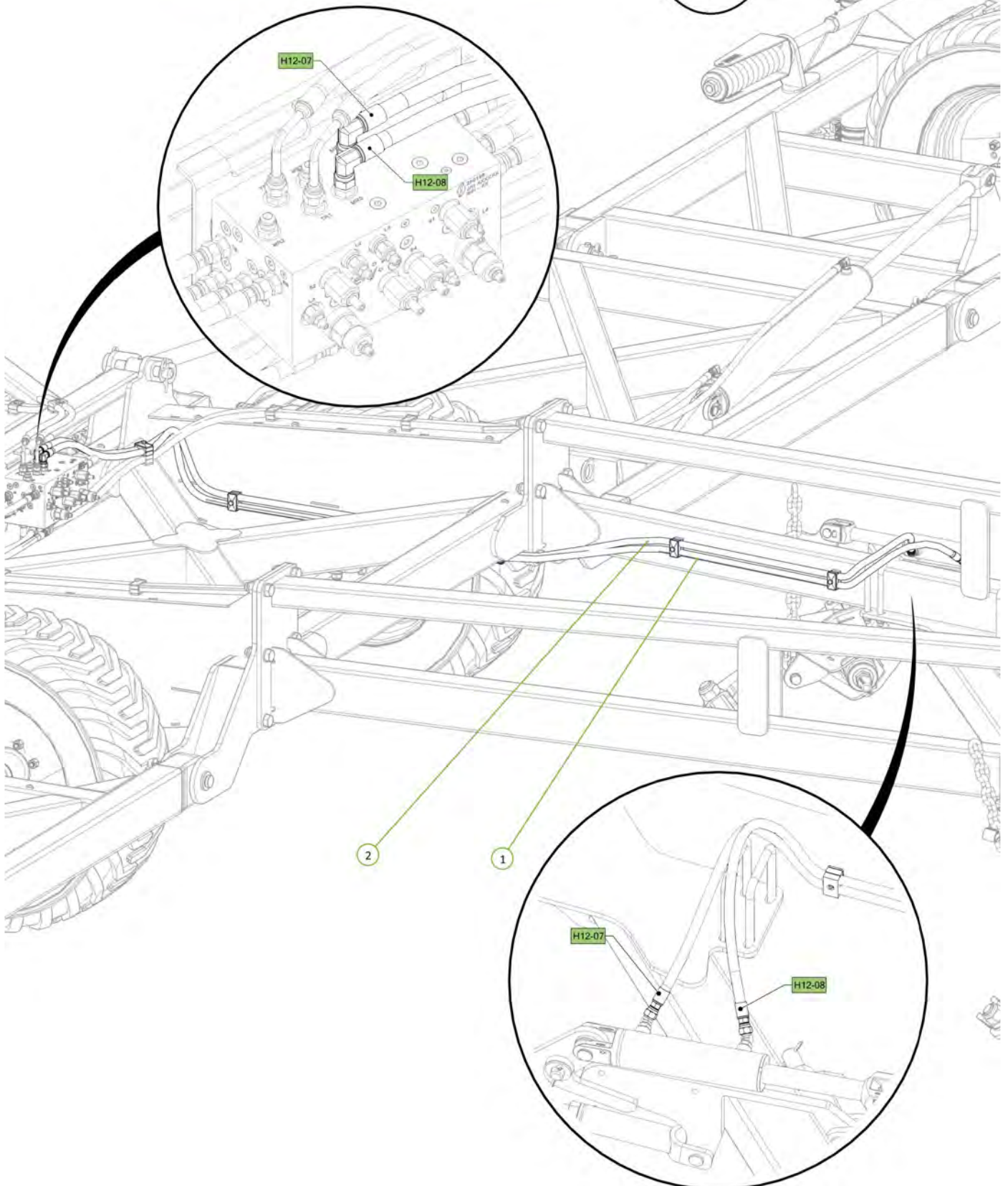

Item No.	Description	Qty	Number
1	Short Lift Arm Assembly	1	0810-167
2	Clevis Pin 25mm x 75mm	1	0801-KE0307-1
3	Cotter Pin M6 x 50mm	1	0261-PINC650
4	Height Adjustor Retaining Clip	1	0801-KE014
5	Washer Flat 1"	1	0232-F1

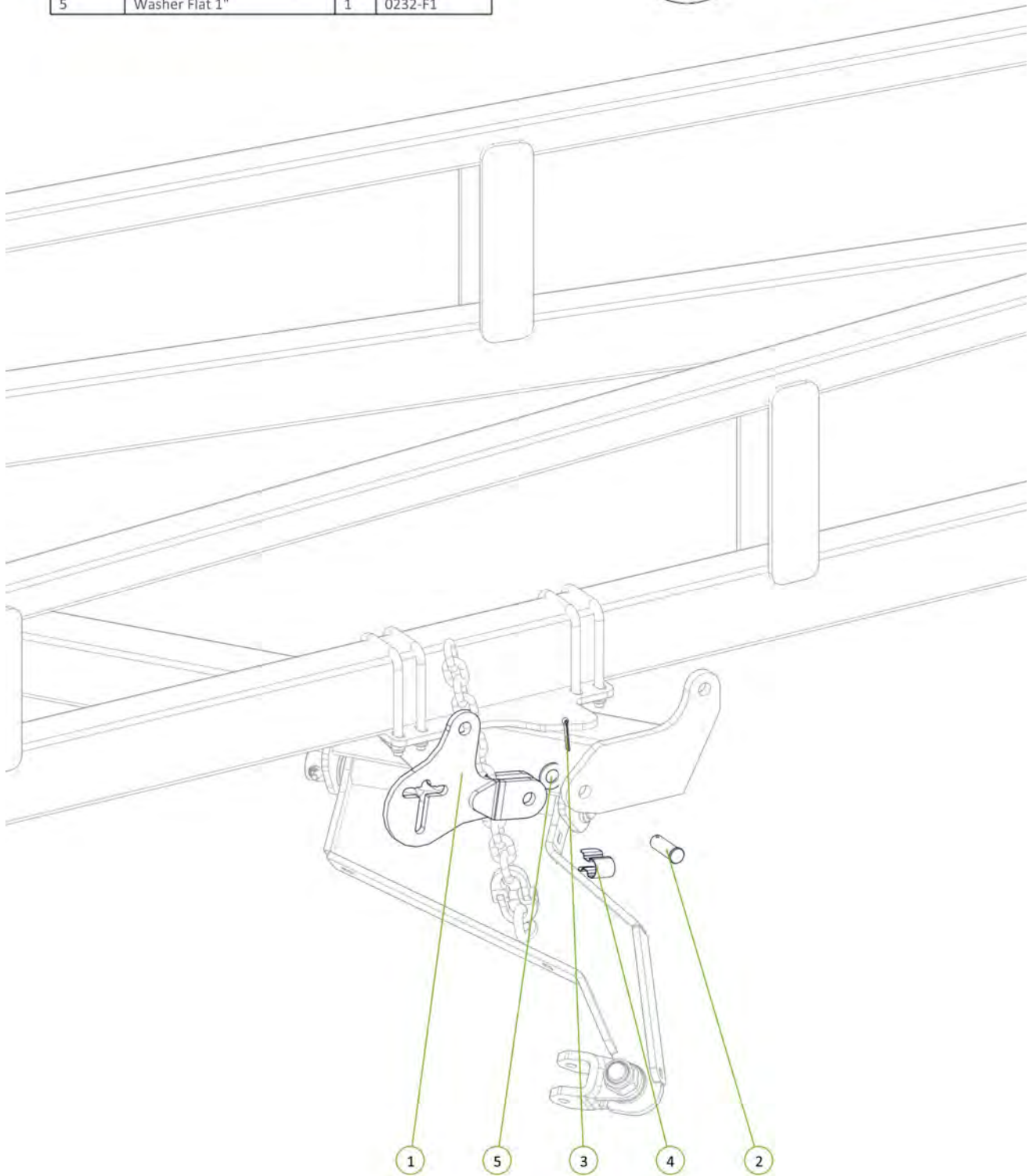

Item No.	Description	Qty	Number
1	Adjuster Mount	1	0810-161
2	Height Adjuster Rod Bolt	1	0810-163
3	Tension Adjuster Body	1	0810-164
4	ACME Lock Nut 1 1/4 - 5NA - 2G	2	0801-PCHTA-5N
5	Clevis Pin 25mm x 75mm	2	0801-KE0307-1
6	Cotter Pin M6 x 50mm	2	0261-PINC650
7	Grease Nipple 1/4" UNF	1	0181-GN1-4
8	Washer Flat 1"	2	0232-F1
9	Washer High Tensile 1 1/4"	1	0232-HT11-4

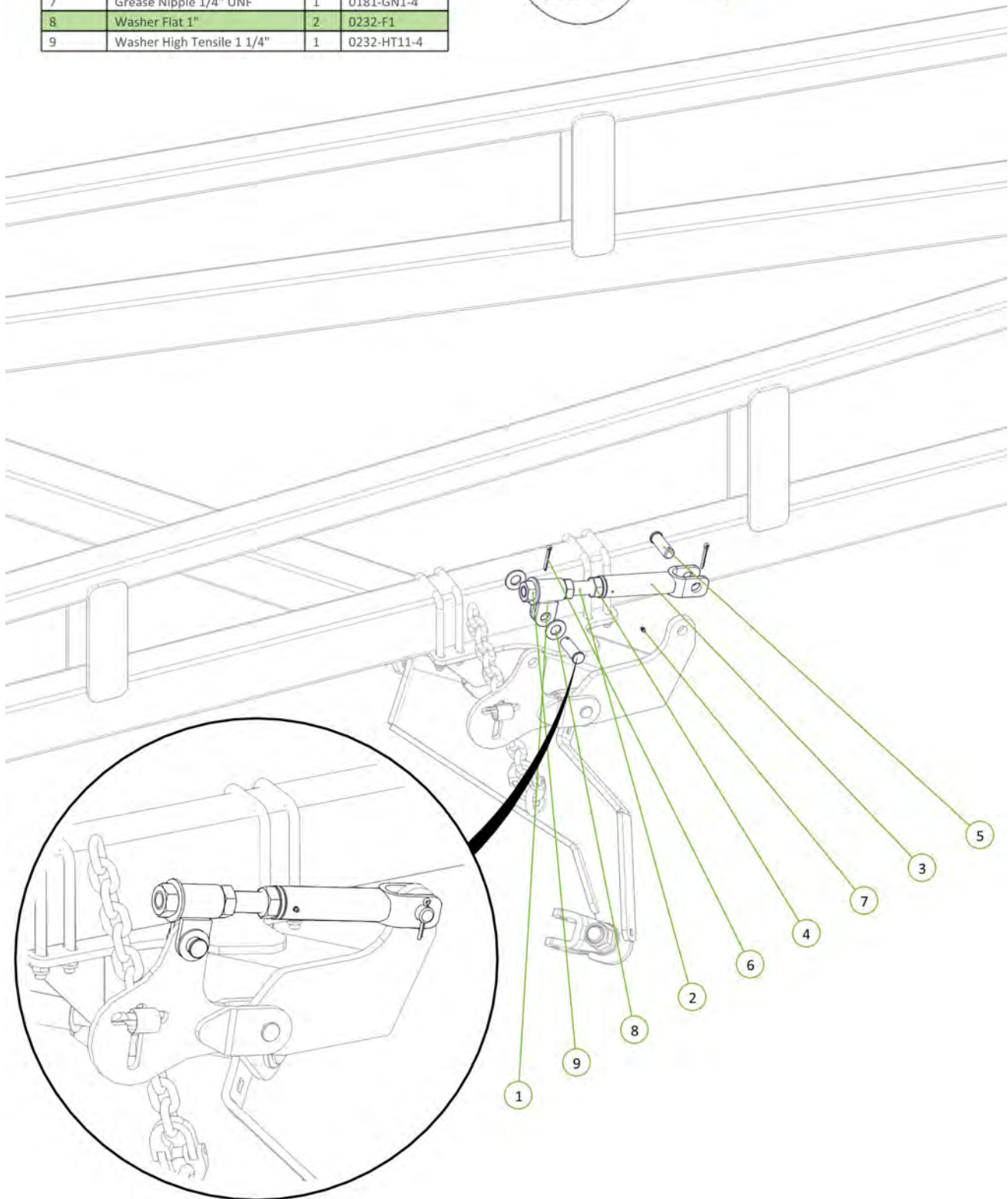

Item No.	Description	Qty	Number
1	Compact Module Lift Arm	1	0810-51
2	Clevis Pin 25mm x 75mm	1	0801-KE0307-1
3	Height Adjustor Retaining Clip	1	0801-KE014
4	Washer Flat 1"	1	0232-F1
5	Cotter Pin M6 x 50mm	1	0261-PINC650

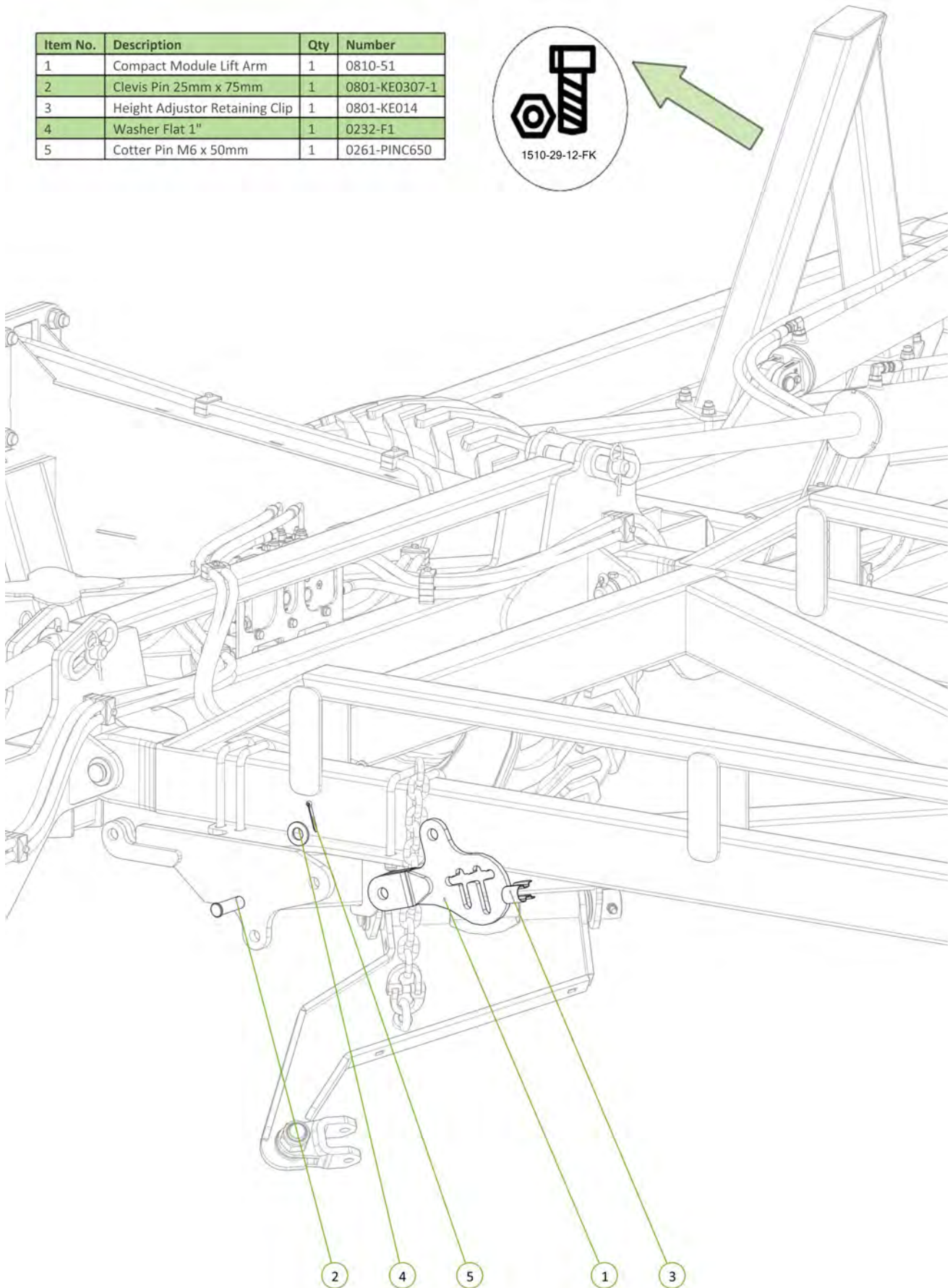

Item No.	Description	Qty	Number
1	Adjustor Linkage	1	0810-88
2	Clevis Pin 25mm x 75mm	1	0801-KE0307-1
3	Cotter Pin M6 x 50mm	1	0261-PINC650
4	Washer Flat 1"	1	0232-F1

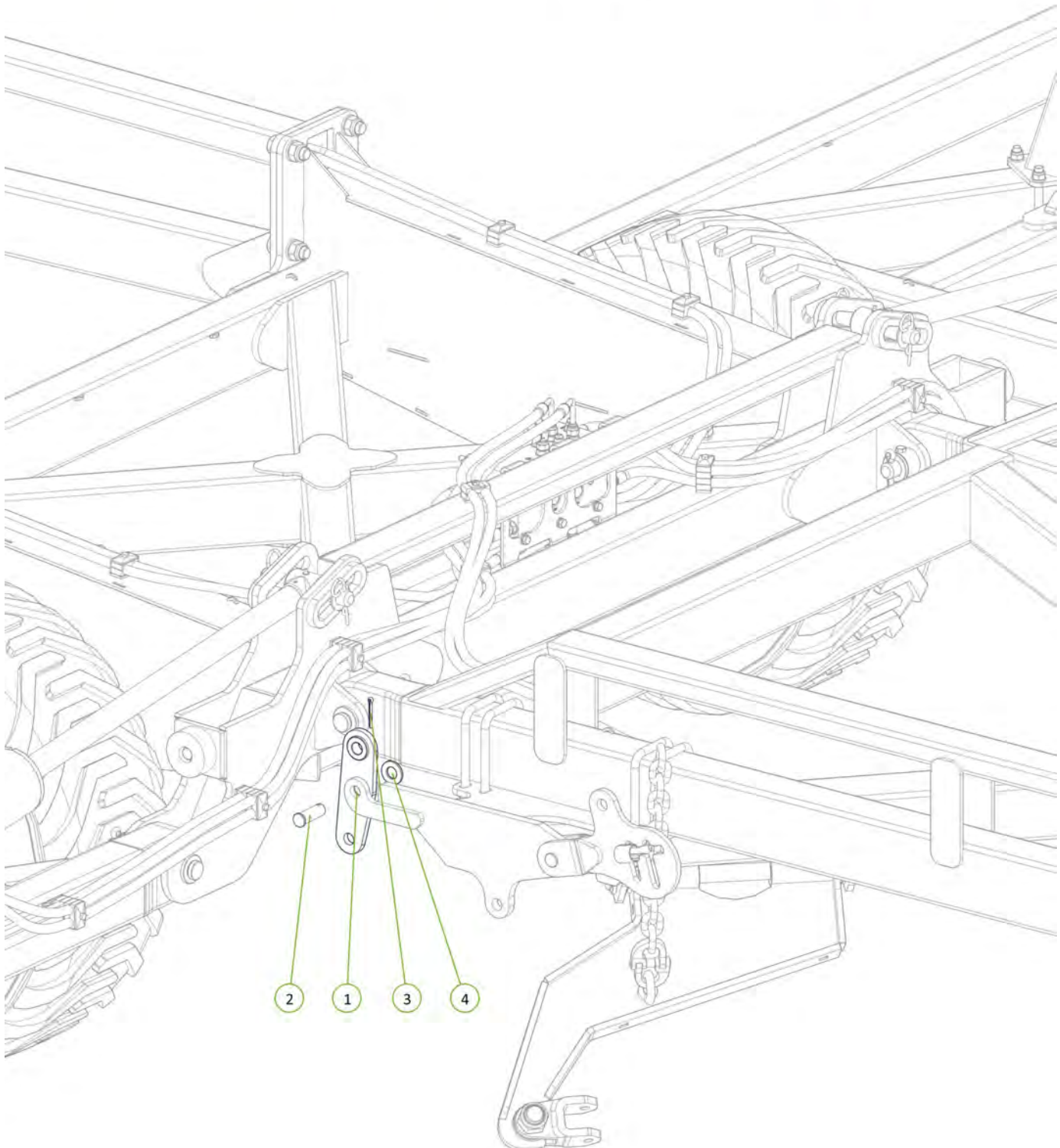

2	Height Adjuster Rod Bolt	1	0810-163
3	Tension Adjuster Body	1	0810-164
4	ACME Lock Nut 1 1/4 - 5NA - 2G	2	0801-PCHTA-5N
5	Clevis Pin 25mm x 75mm	2	0801-KE0307-1
6	Cotter Pin M6 x 50mm	2	0261-PINC650
7	Grease Nipple 1/4" UNF	1	0181-GN1-4
8	Washer Flat 1"	2	0232-F1
9	Washer High Tensile 1 1/4"	1	0232-HT11-4

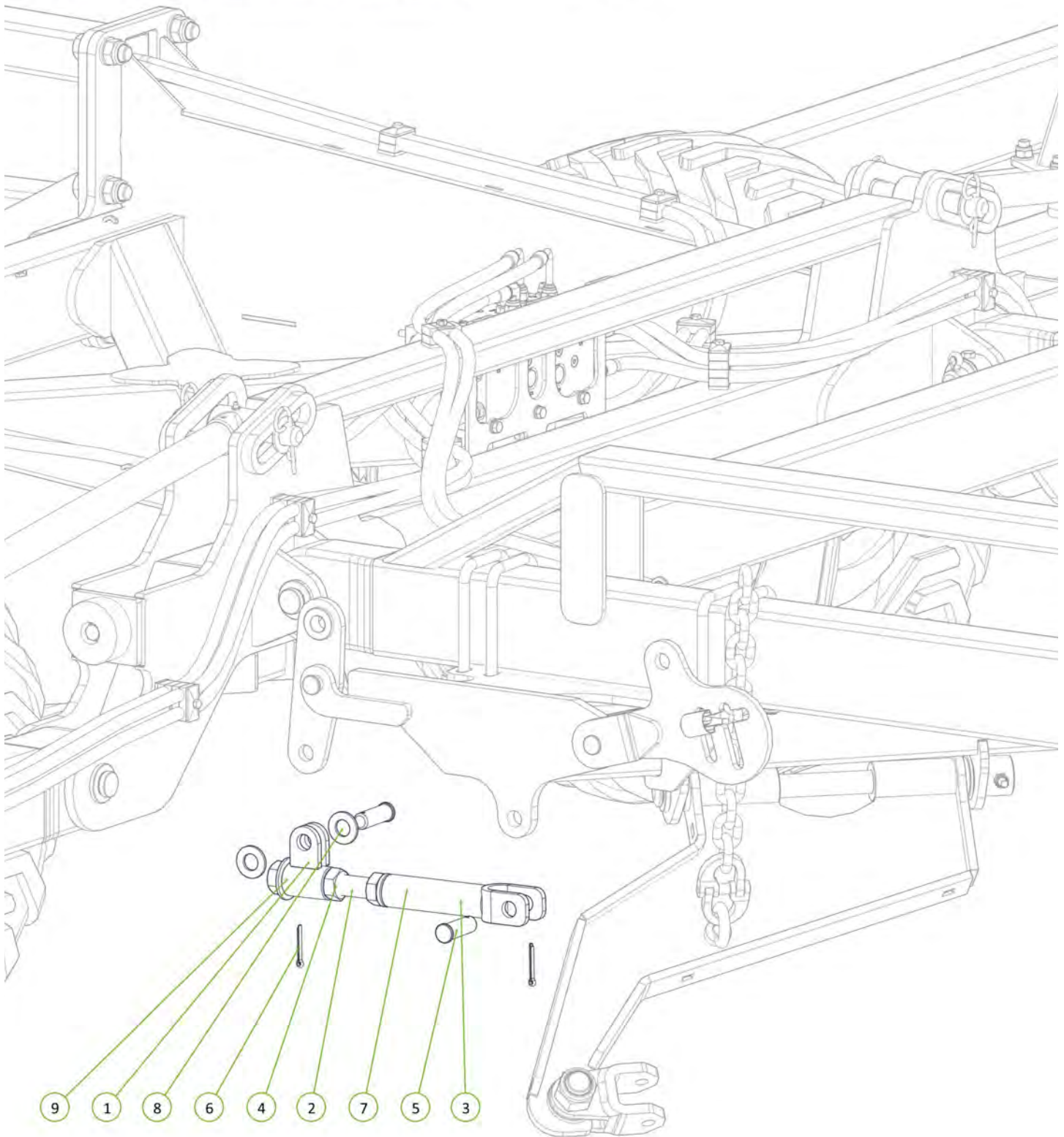

Item No.	Description	Qty	Number
1	2.5" Bore x 6" Stroke 1.5" Rod Side Port Cylinder	1	0311-256SP

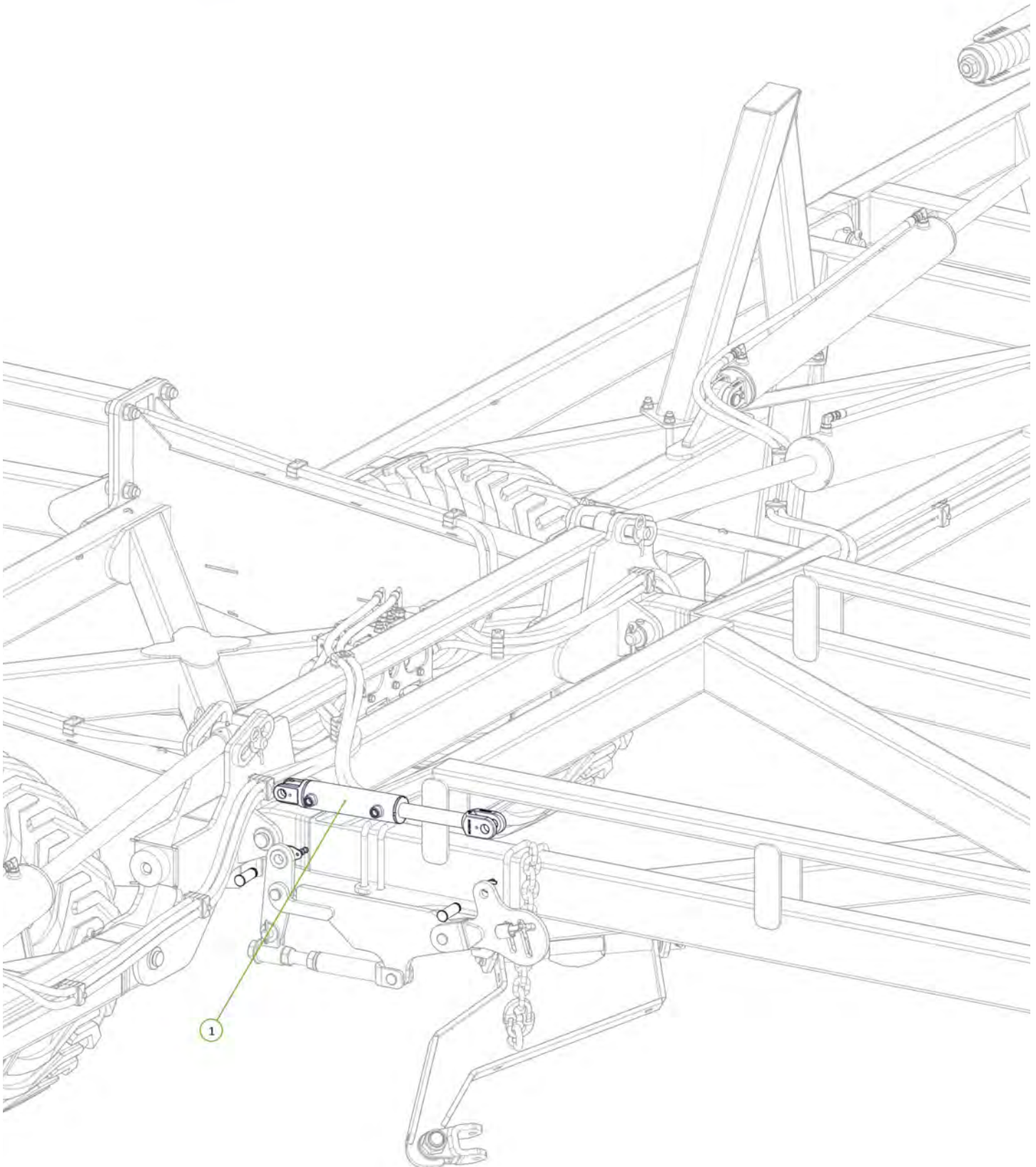

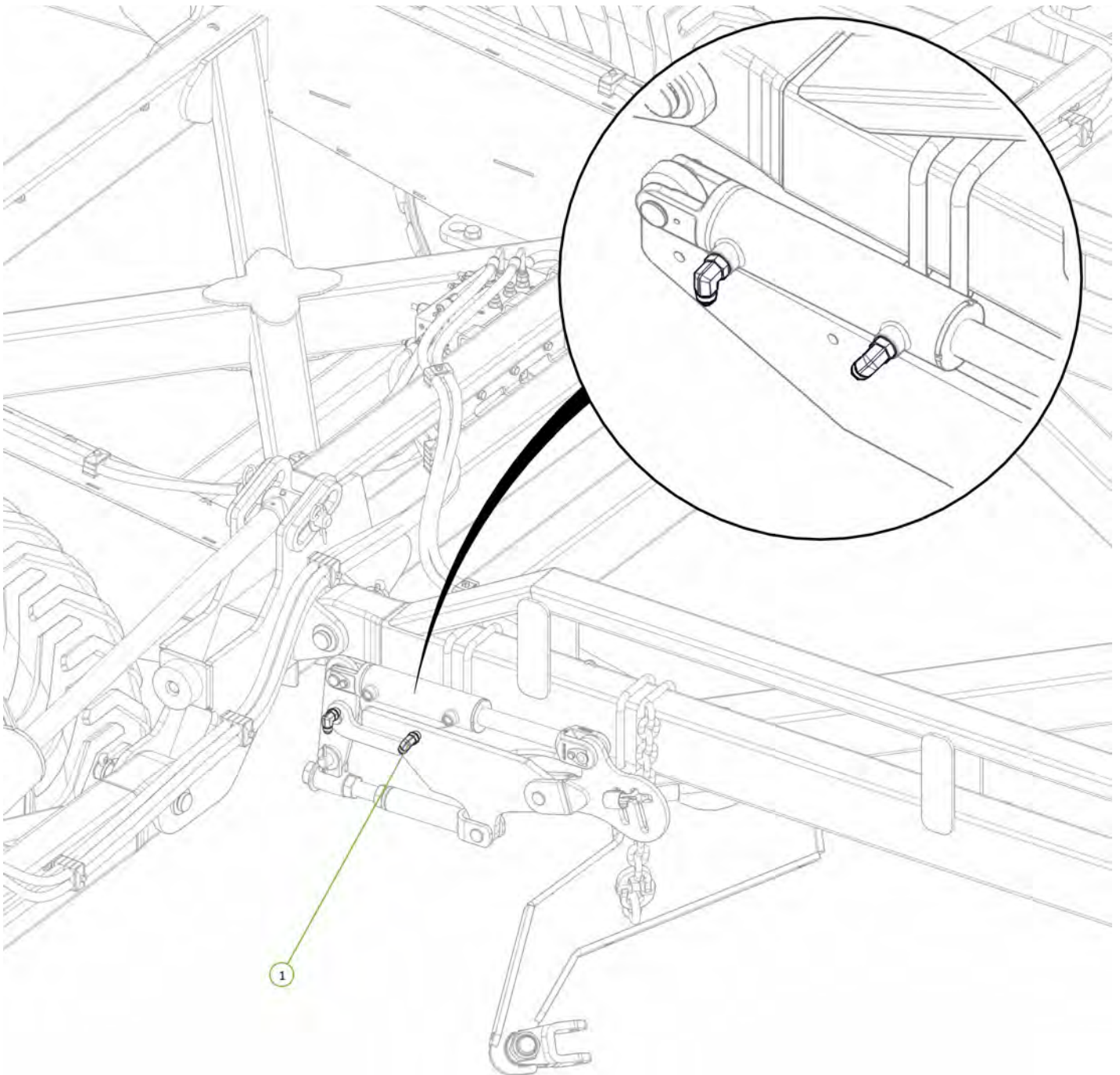

Item No.	Description	Qty	Number
1	3/4" JIC Male 3/4" UN O Ring Male 90° Elbow	2	0323-S91-1212



Item No.	Description	Qty	Number
1	Compact Module Lift Arm	1	0810-51
2	Clevis Pin 25mm x 75mm	1	0801-KE0307-1
3	Height Adjustor Retaining Clip	1	0801-KE014
4	Washer Flat 1"	1	0232-F1
5	Cotter Pin M6 x 50mm	1	0261-PINC650

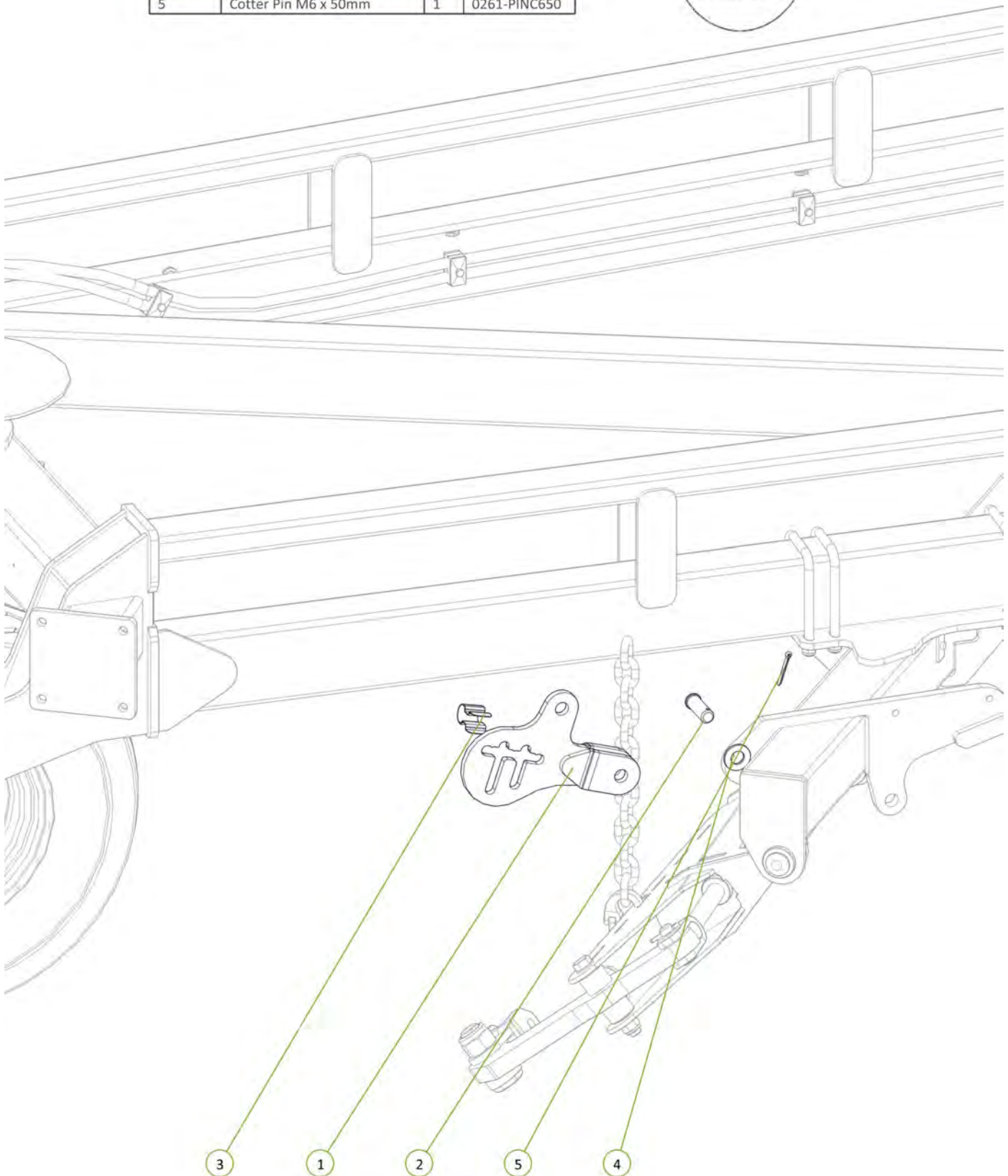
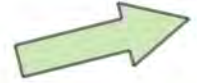



Item No.	Description	Qty	Number
1	Adjustor Linkage	1	0810-88
2	Clevis Pin 25mm x 75mm	1	0801-KE0307-1
3	Cotter Pin M6 x 50mm	1	0261-PINC650
4	Washer Flat 1"	1	0232-F1

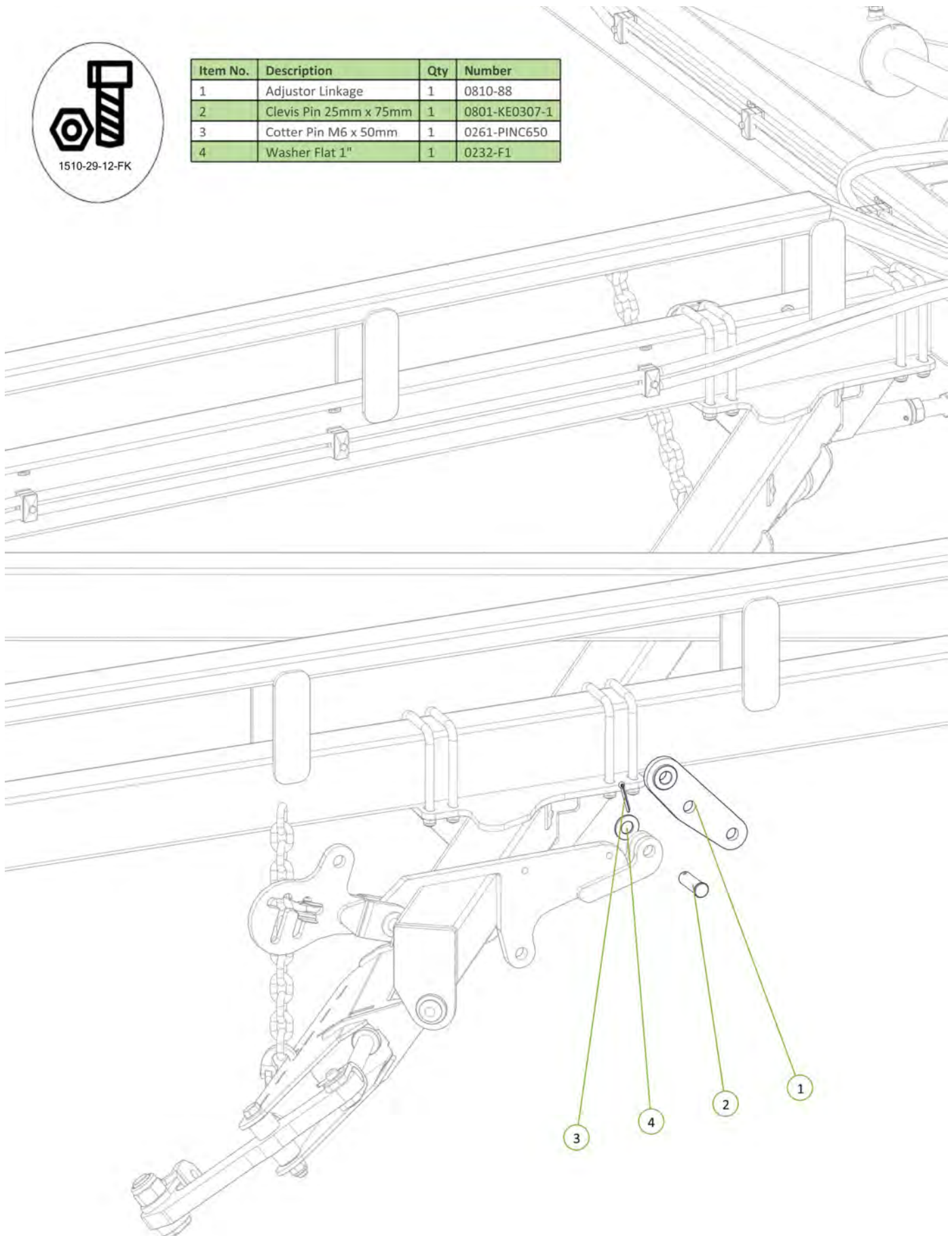

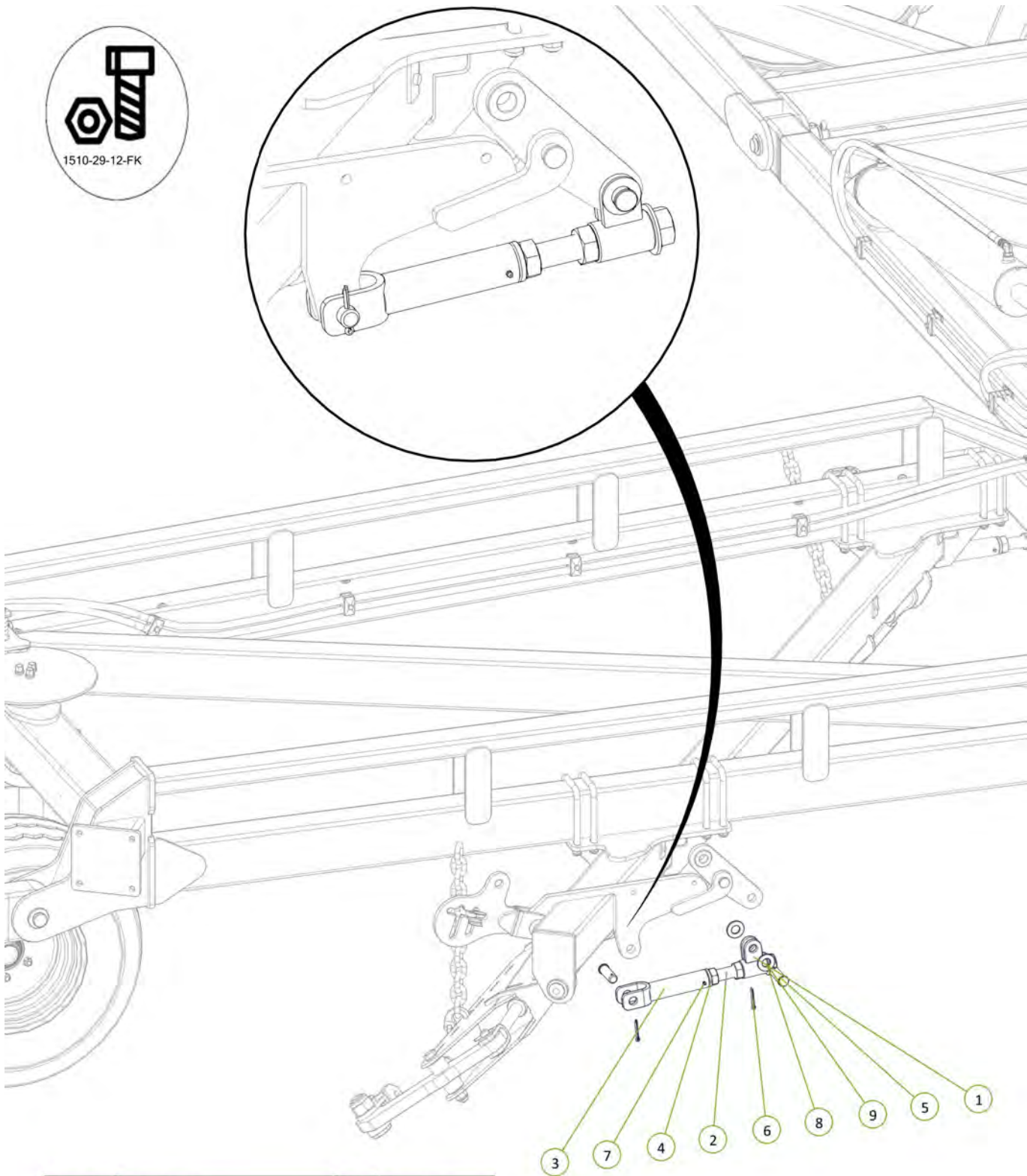

Item No.	Description	Qty	Number
1	Adjuster Mount	1	0810-161
2	Height Adjuster Rod Bolt	1	0810-163
3	Tension Adjuster Body	1	0810-164
4	ACME Lock Nut 1 1/4 - 5NA - 2G	2	0801-PCHTA-5N
5	Clevis Pin 25mm x 75mm	2	0801-KE0307-1
6	Cotter Pin M6 x 50mm	2	0261-PINC650
7	Grease Nipple 1/4" UNF	1	0181-GN1-4
8	Washer Flat 1"	2	0232-F1
9	Washer High Tensile 1 1/4"	1	0232-HT11-4

Item No.	Description	Qty	Number
1	2.5" Bore x 6" Stroke 1.5" Rod Side Port Cylinder	1	0311-256SP

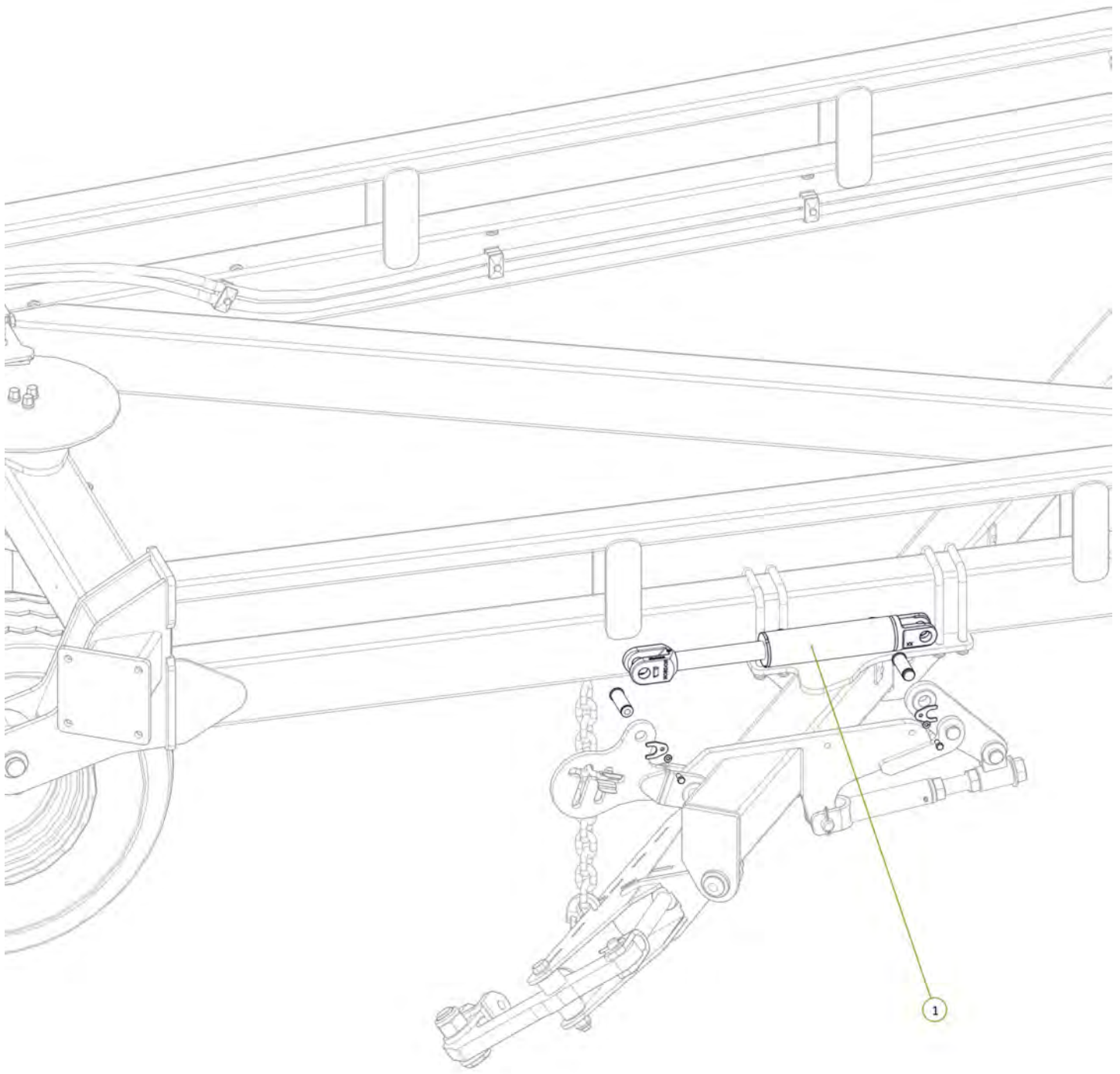

Item No.	Description	Qty	Number
1	3/4" JIC Male 3/4" UN O Ring Male 90° Elbow	2	0323-S91-1212

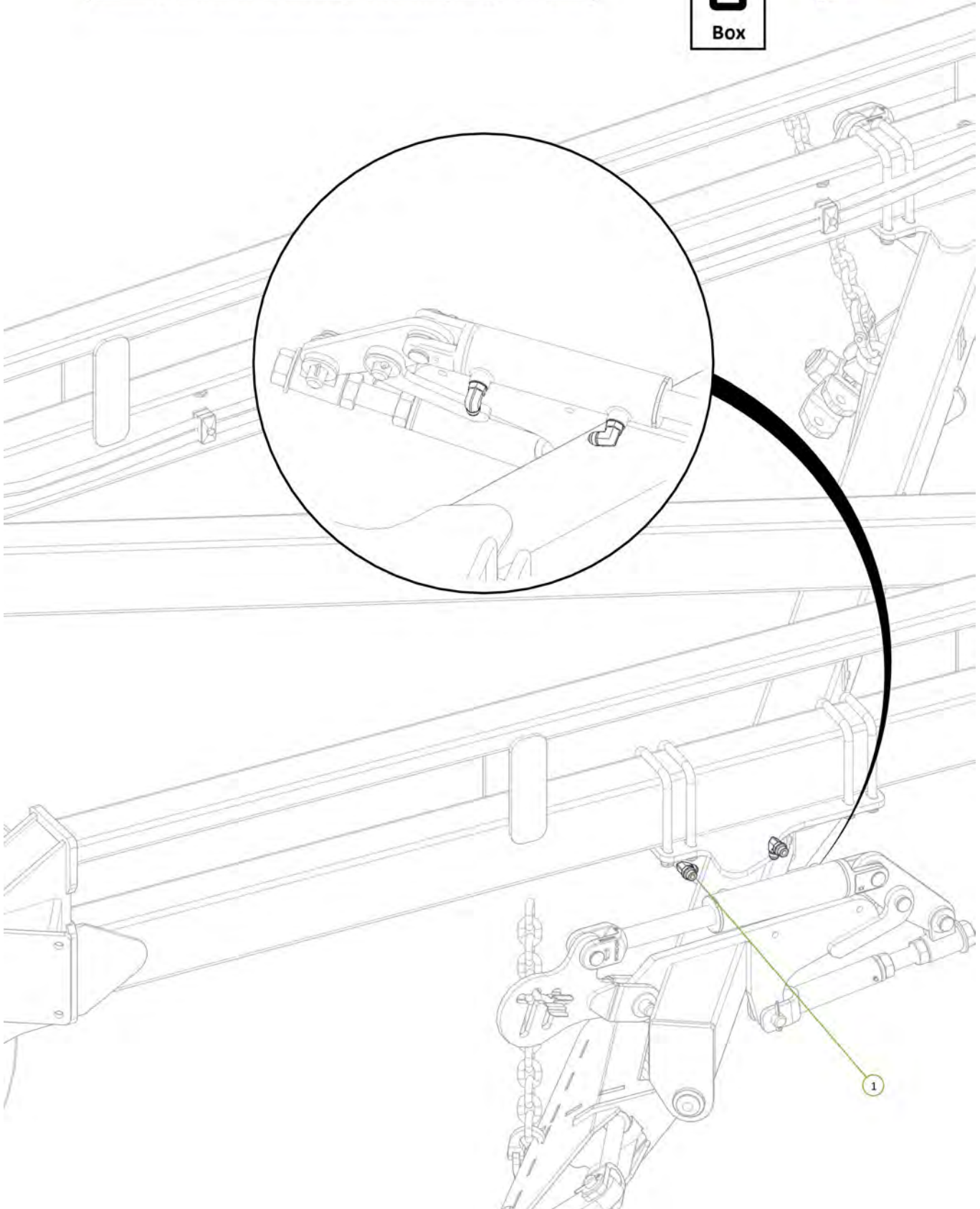

Item No.	Description	Qty	Number
1	ME2 Port to Rear Module Extend Tee	1	H12-11
2	MR2 Port to Rear Module Retract Tee	1	H12-12
3	3/4" JIC Male Tee	2	0324-S19-121212

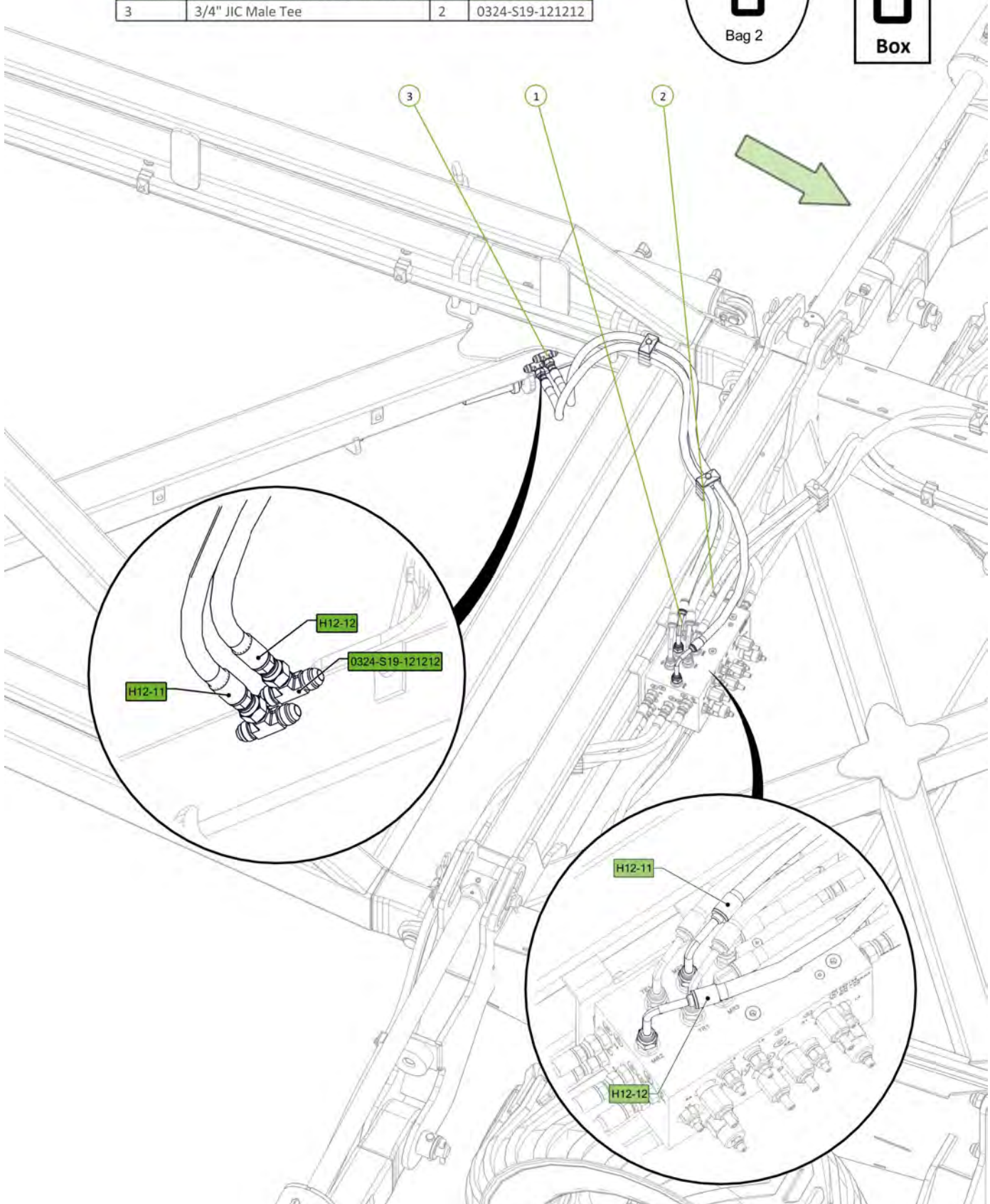

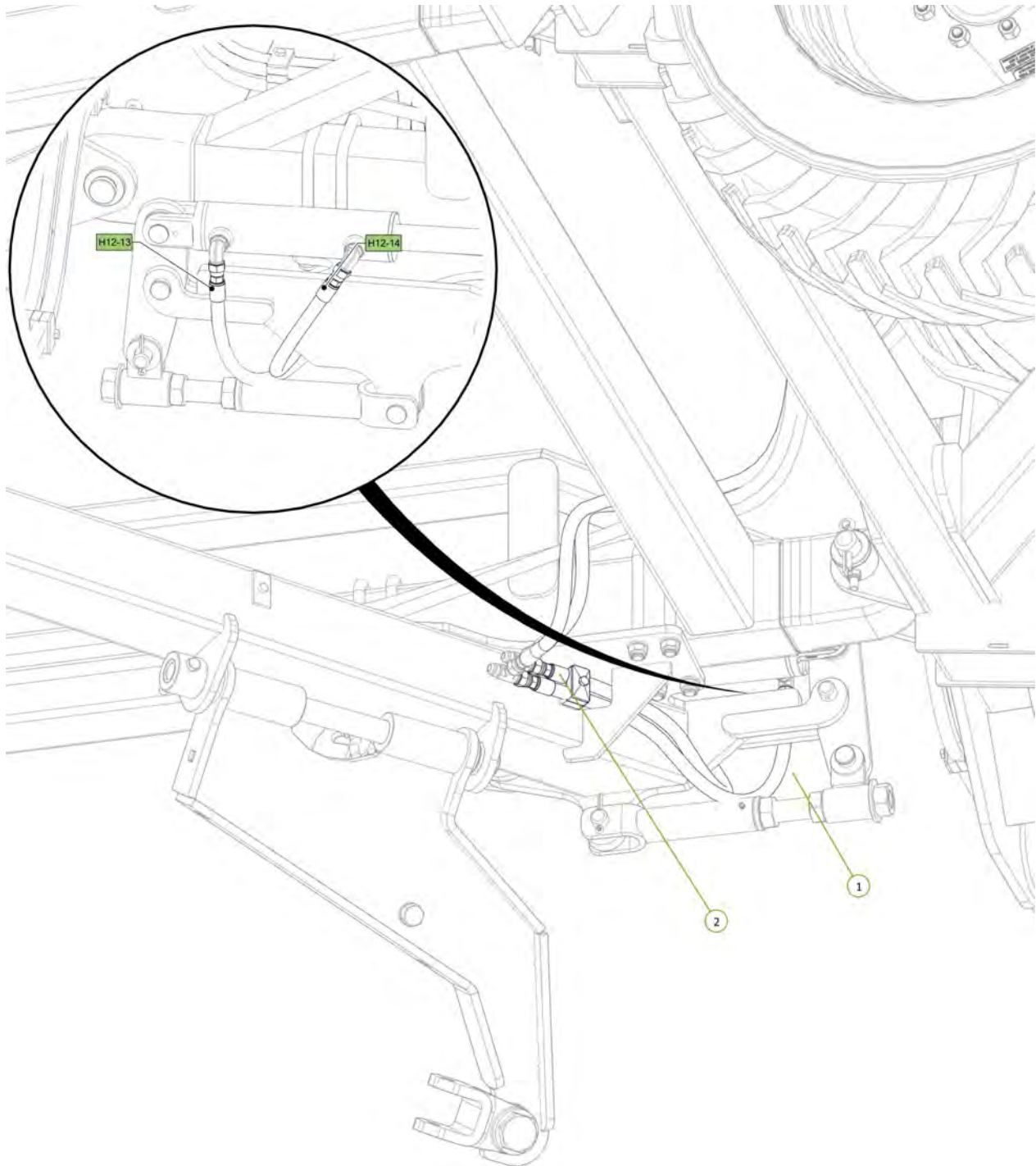

Item No.	Description	Qty	Number
1	Rear Module Extend Tee to LH Rear Module Cyl Extend Port	1	H12-13
2	Rear Module Retract Tee to LH Rear Module Cyl Retract Port	1	H12-14



Item No.	Description	Qty	Number
1	Rear Module Extend Tee to RH Rear Module Cyl Extend Port	1	H12-15
2	Rear Module Retract Tee to RH Rear Module Cyl Retract Port	1	H12-16

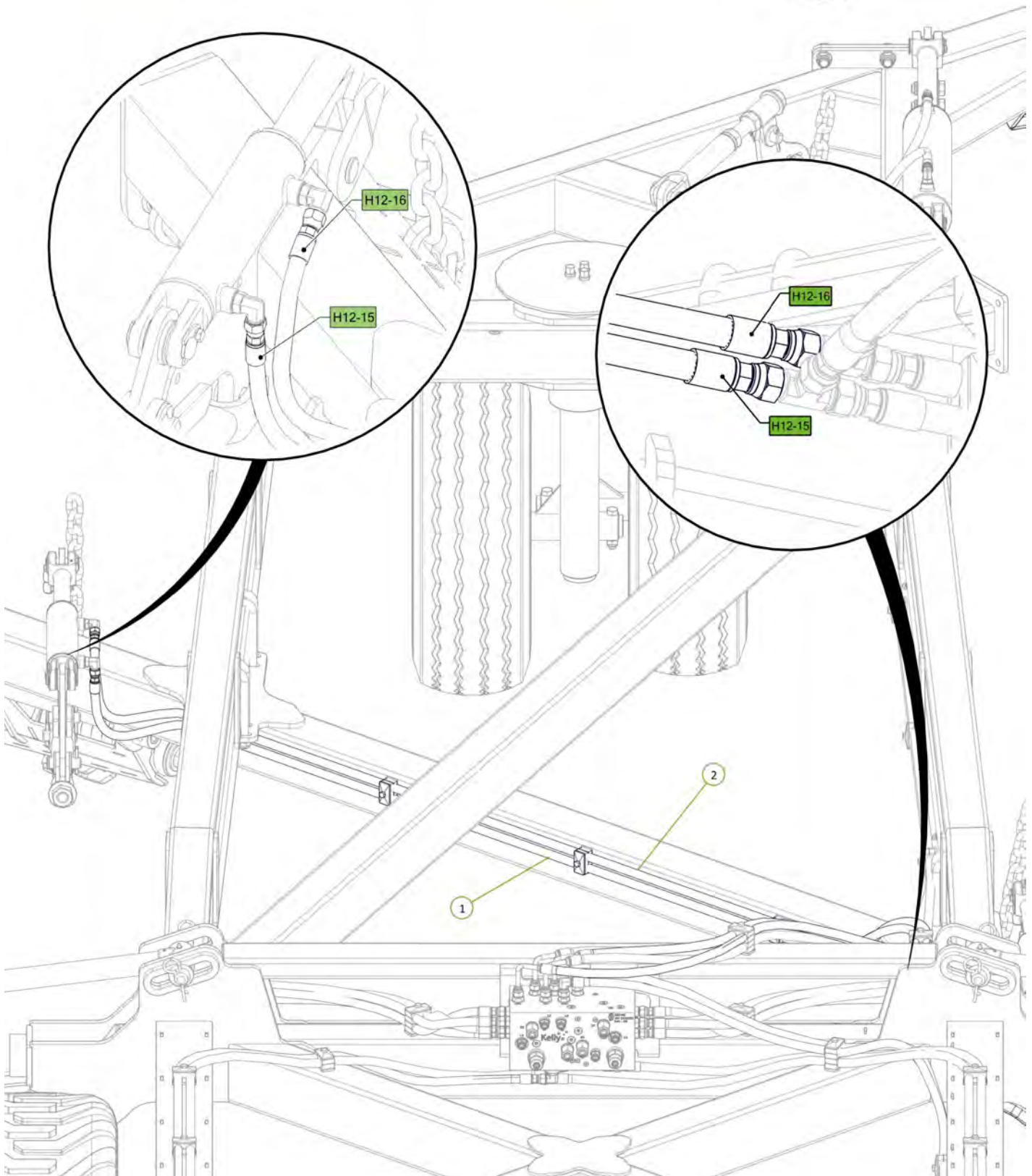
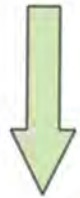

Item No.	Description	Qty	Number
1	Angled Chain Carrier Beam	1	0810-66
2	500mm Pedestal	2	0810-52
3	U-Bolt M16 x 162 Deep x 129 Wide	4	0271-16162129U
4	U-Bolt M16 x 114 Deep x 106 Wide	4	0271-16114106U
5	Washer Flat M16	16	0231-F16
6	Nyloc Nut M16	16	0221-NYL16

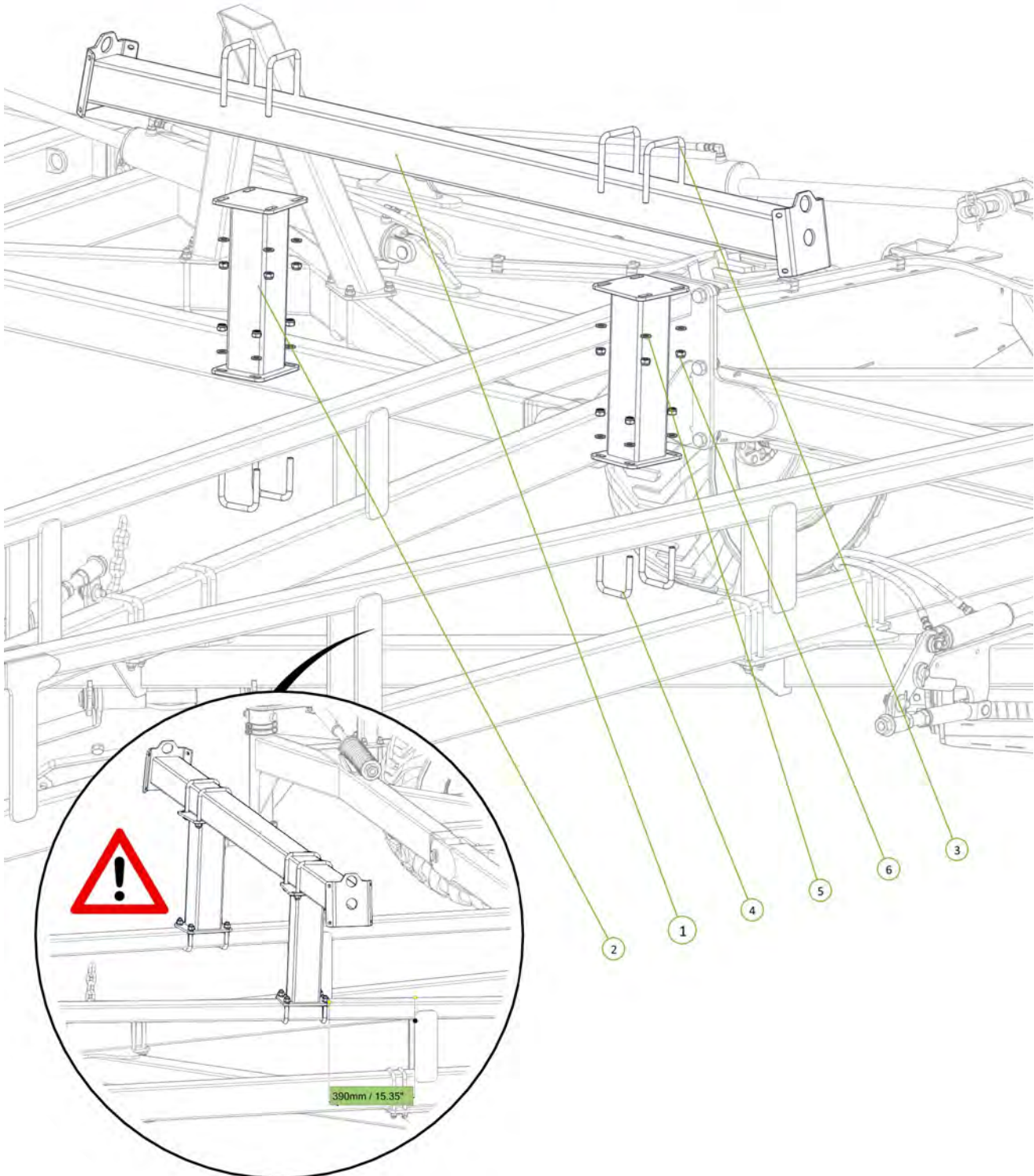

Item No.	Description	Qty	Number
1	Extended Chain Carrier Bolt on End	2	0810-17LE
2	M12 x 30 Coach Head Bolt	8	0215-CH1230
3	Washer Flat M12	8	0231-F12
4	Nyloc Nut M12	8	0221-NYL12

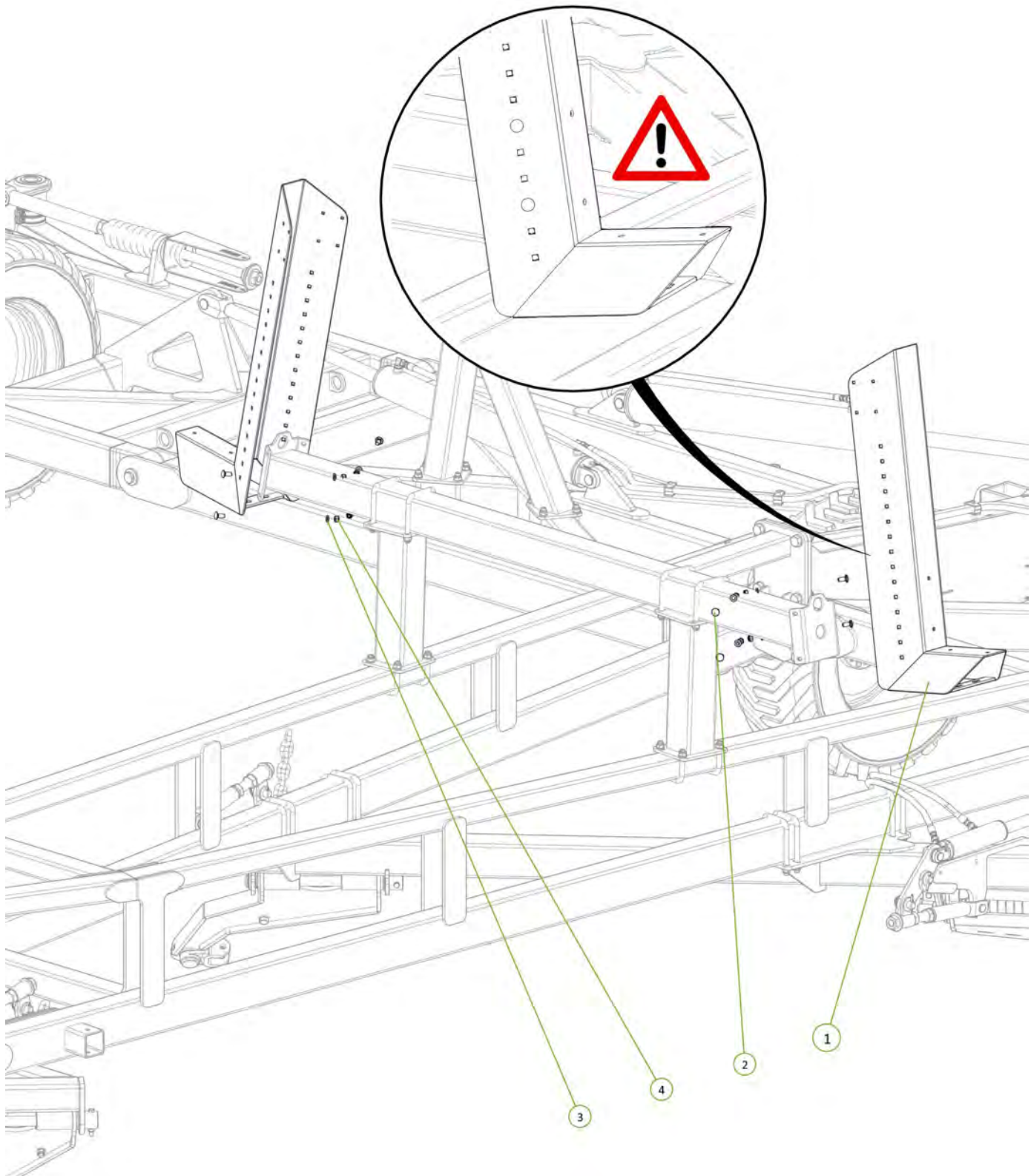

Item No.	Description	Qty	Number
1	Angled Chain Carrier Beam	1	0810-66
2	500mm Pedestal	2	0810-52
3	U-Bolt M16 x 104 Wide x 85 Deep	4	0271-1610686U
4	U-Bolt M16 x 162 Deep x 129 Wide	4	0271-16162129U
5	Nyloc Nut M16	16	0221-NYL16
6	Washer Flat M16	16	0231-F16

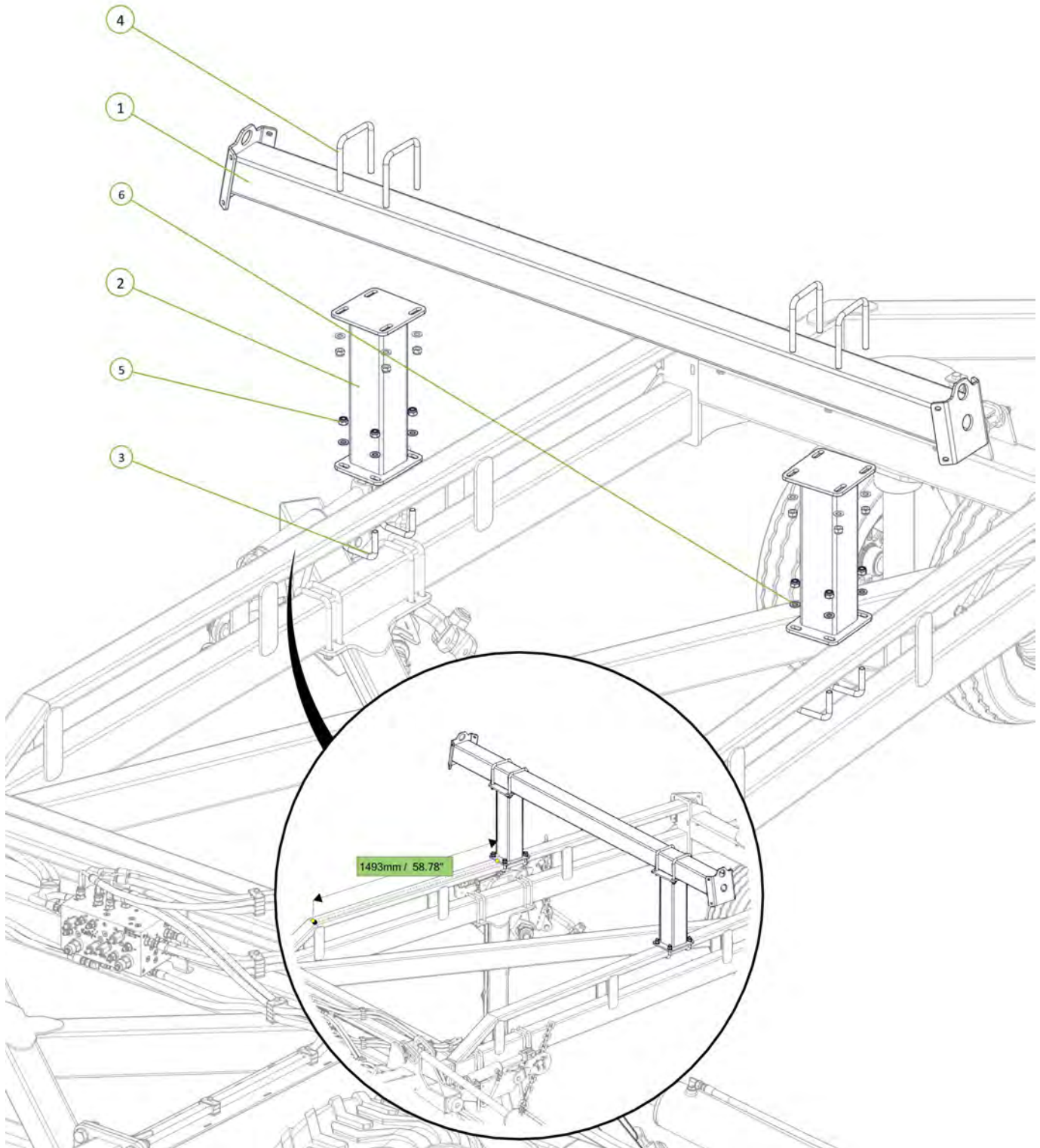

Item No.	Description	Qty	Number
1	Extended Chain Carrier Bolt on End	2	0810-17LE
2	M12 x 30 Coach Head Bolt	8	0215-CH1230
3	Nyloc Nut M12	8	0221-NYL12
4	Washer Flat M12	8	0231-F12

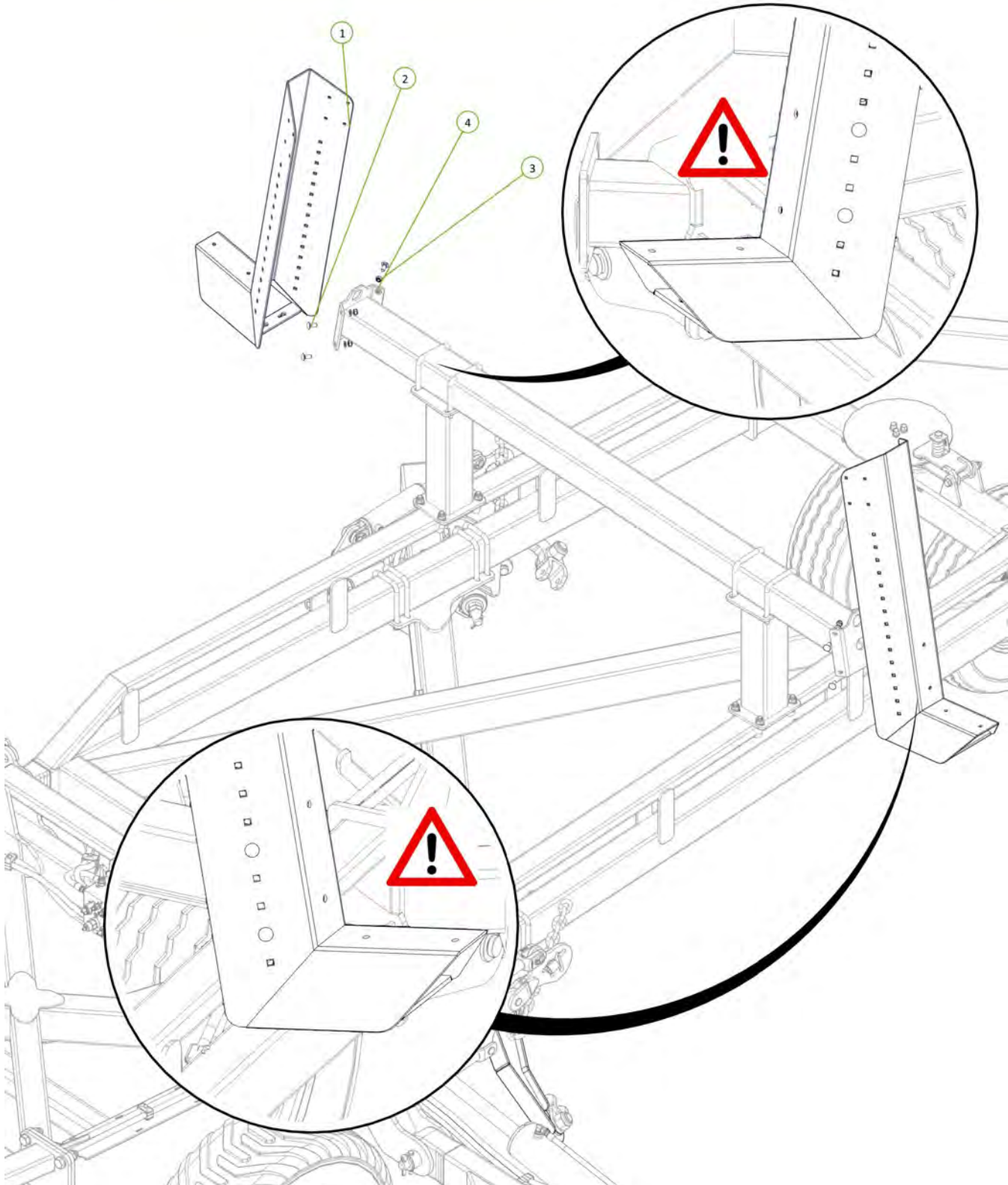
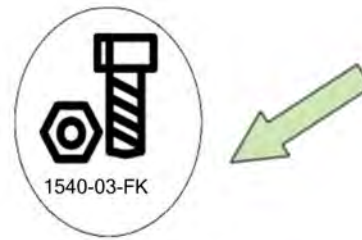

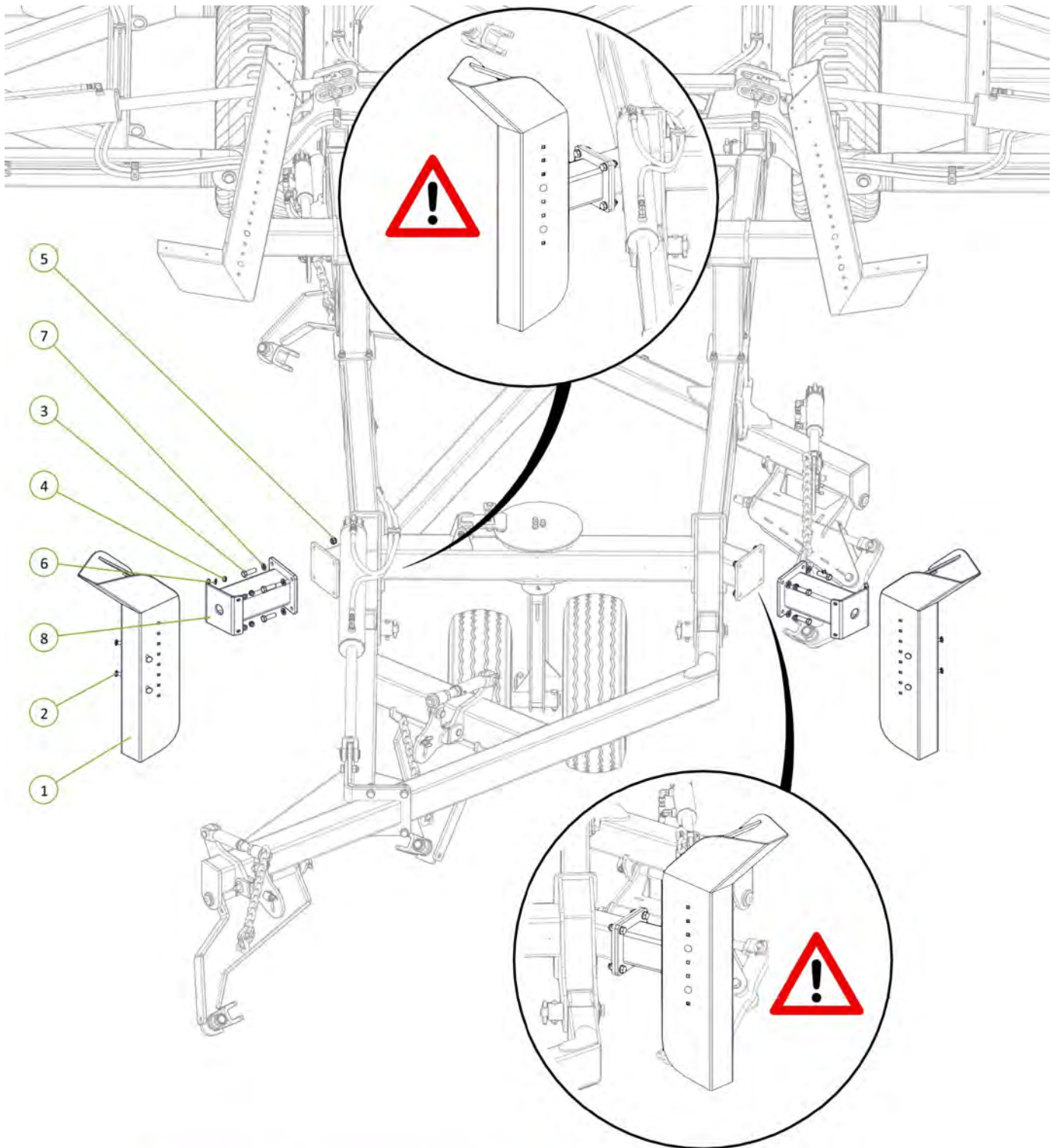

Item No.	Description	Qty	Number
1	Chain Catcher	2	0810-67
2	M12 x 30 Coach Head Bolt	8	0215-CH1230
3	M16 x 55 Class 8.8 ZP Bolt	8	0211-1655
4	Nyloc Nut M12	8	0221-NYL12
5	Nyloc Nut M16	8	0221-NYL16
6	Washer Flat M12	8	0231-F12
7	Washer Flat M16	16	0231-F16
8	Outtrigger	2	0810-236



Item No.	Description	Qty	Number
1	Nyloc Nut M12	8	0221-NYL12
2	Round Tube Insert 60.3 x 3.2-5mm	4	0264-RTRI-5584
3	U-Bolt M12 x 106 Deep x 79 Wide	2	0271-1210679U
4	U-Bolt M12 x 107 Deep x 106 Wide	2	0271-12107106U
5	Washer Flat M12	8	0231-F12
6	Left Hand M	1	0810-19L
7	Right Hand M	1	0810-18R



1502-FK-1540-03A-
2-AS1-USA

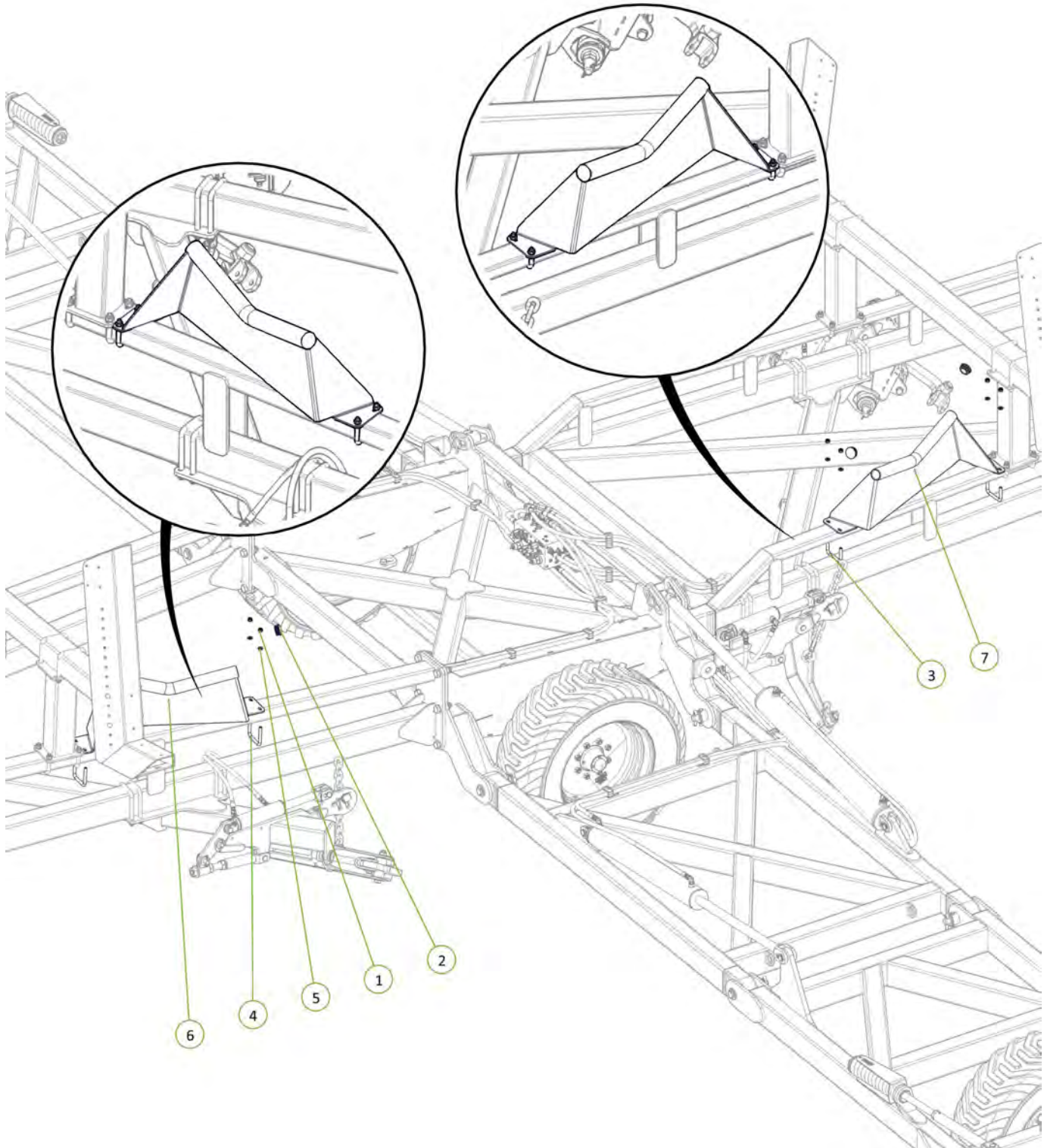

Item No.	Description	Qty	Number
1	M12 x 30 Class 8.8 ZP Bolt	16	0211-1230
2	Nyloc Nut M12	16	0221-NYL12
3	Washer Flat M12	32	0231-F12
4	Chain Retainer Plate	4	0800-360



1502-FK-1540-02A-USA
/ 1502-FK-1540-03A-2-USA

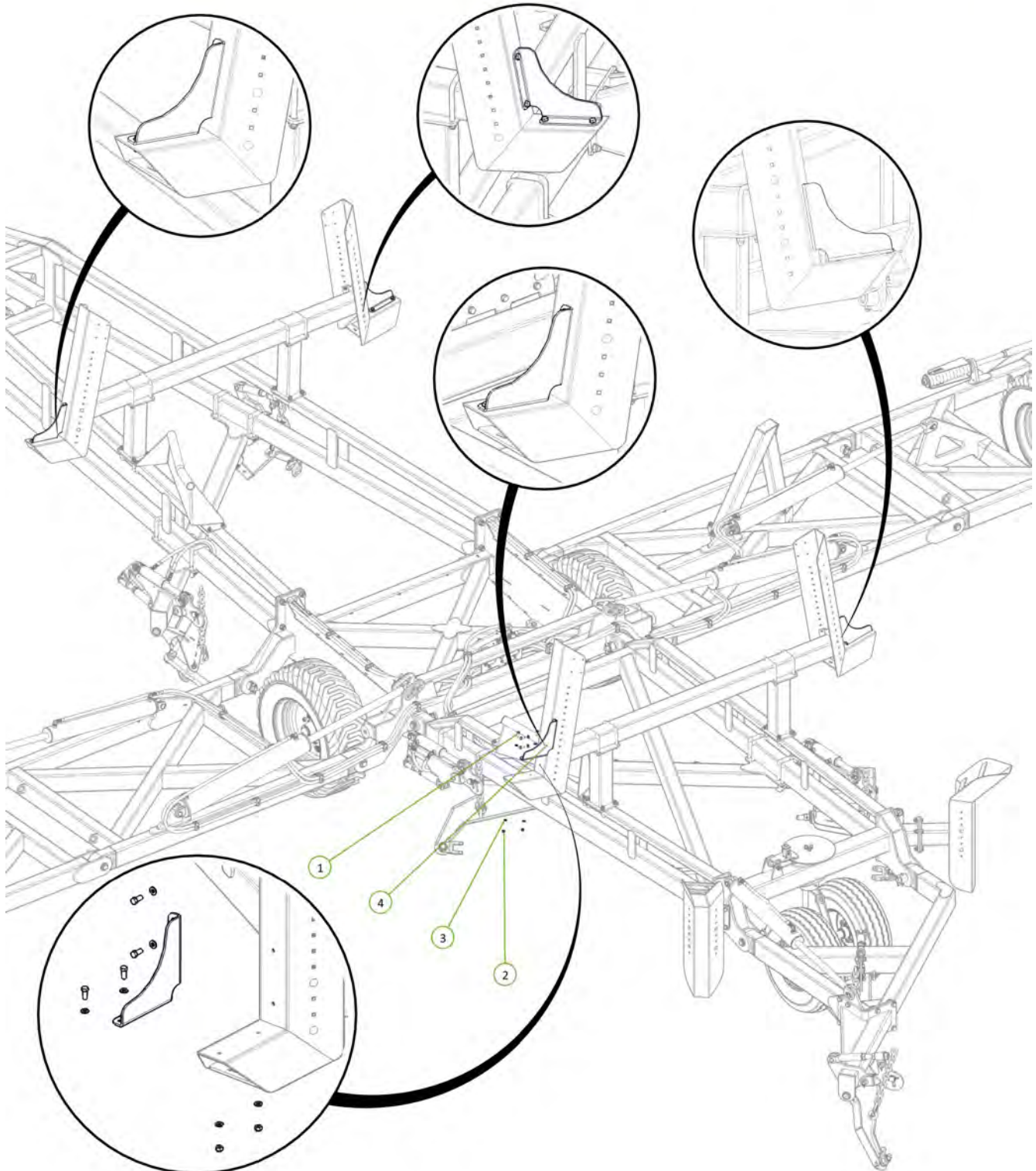

Item No.	Description	Qty	Number
1	SMV Sign Bracket	1	0800-195.1
2	Slow Moving Vehical Sign	1	0801-FBSMVTUF
3	M6 x 20 Trilobe self tapping Screw	4	0211-M620MZPHTF

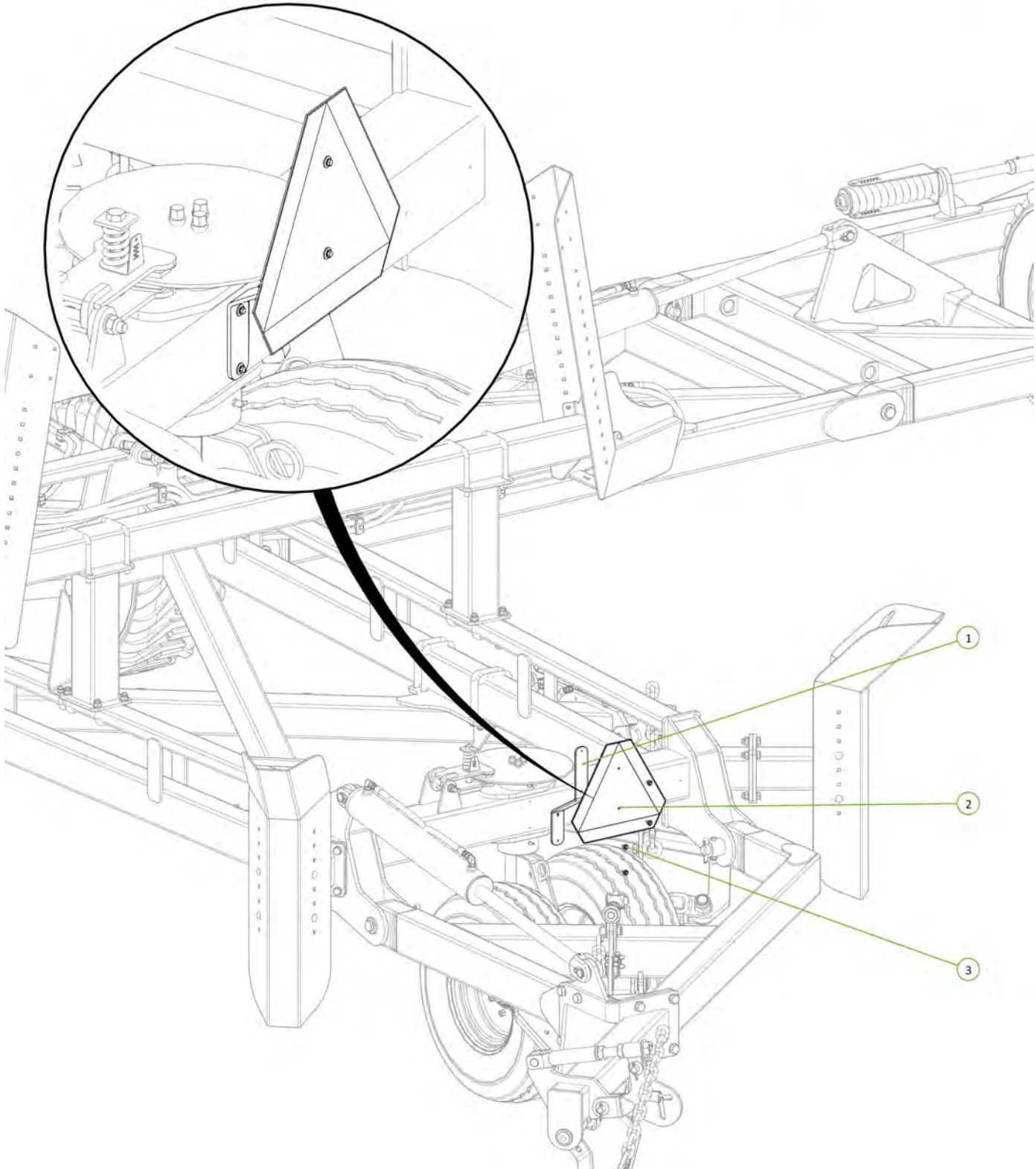

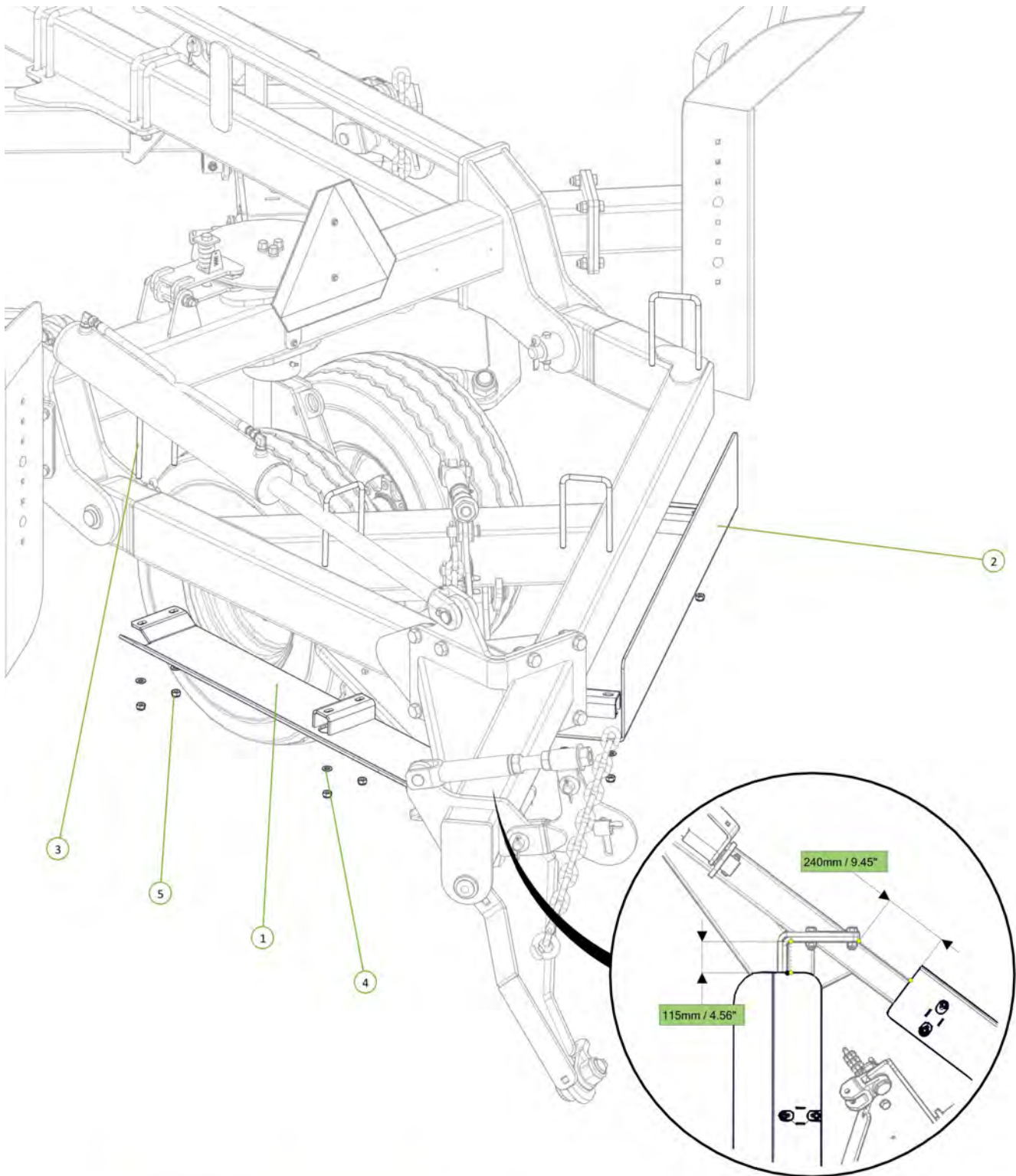

Item No.	Description	Qty	Number
1	Rear Guard 40'	1	1510-229
2	Rear Tail Guard	1	1610-188
3	U-Bolt M12 x 185 Deep x 104 Wide	4	0271-1218
4	Washer Flat M12	8	0231-F12
5	Nyloc Nut M12	8	0221-NYL12



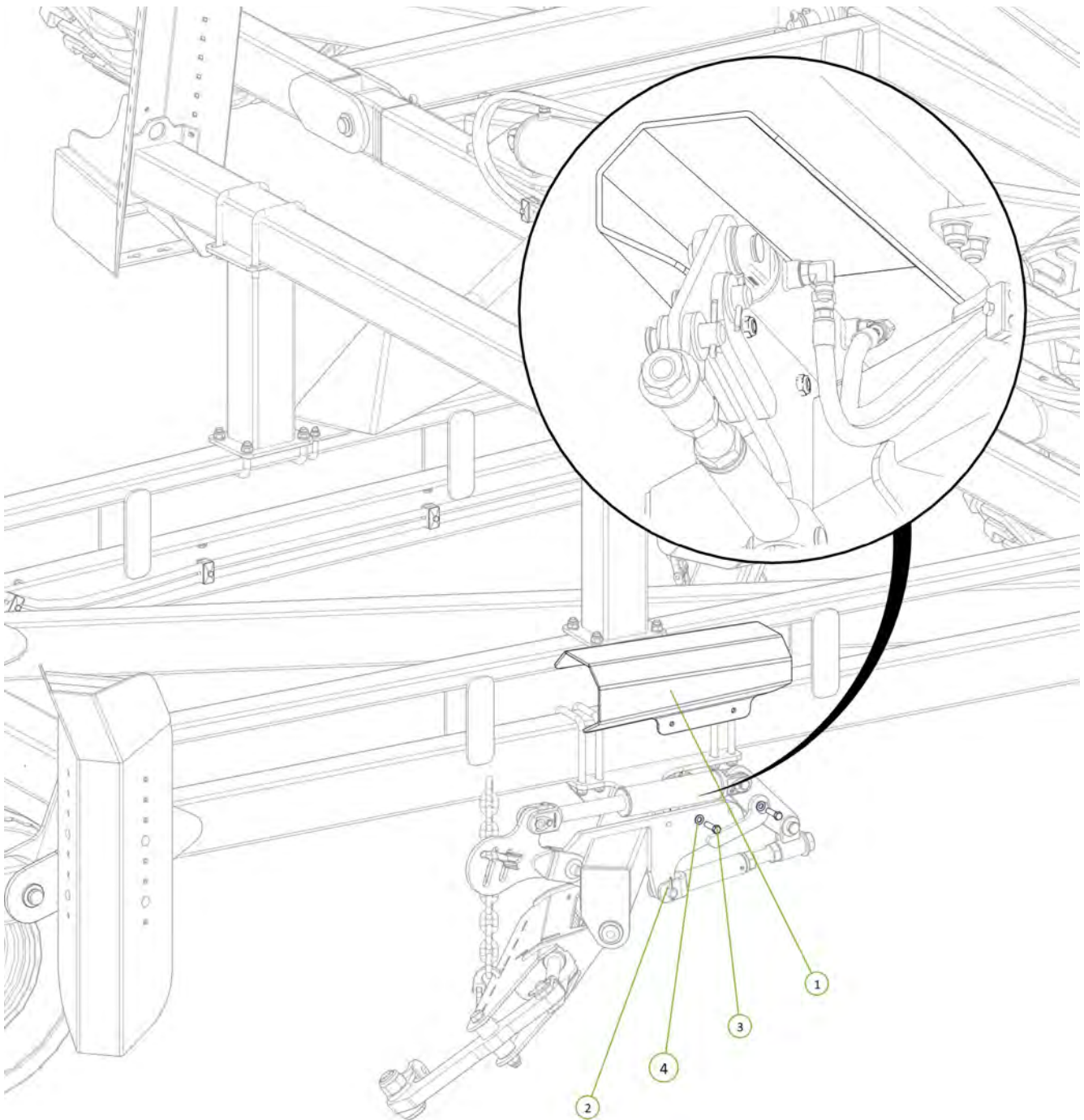

Item No.	Description	Qty	Number
1	Module Cylinder Guard	1	0800-167.3
2	Nyloc Nut M12	2	0221-NYL12
3	M12 x 45 grade 8.8 ZP Bolt	2	0211-1245
4	Washer Flat M12	4	0231-F12



Item No.	Description	Qty	Number
1	Operator Manual Cannister	1	0801-OMC-1
2	M6 x 20 Trilobe self tapping ScREW	3	0211-M620MZPHTF
3	20mm Bolt Swivel Unit	1	0802-PCHB55
4	M20 x 110 grade 10.9 ZP Short Thread Bolt	1	0211-20110 ST
5	Nyloc Nut M20	1	0221-NYL20
6	Ratcheting Gear Wrench 1 3/4"	1	0802-GW1 3-4

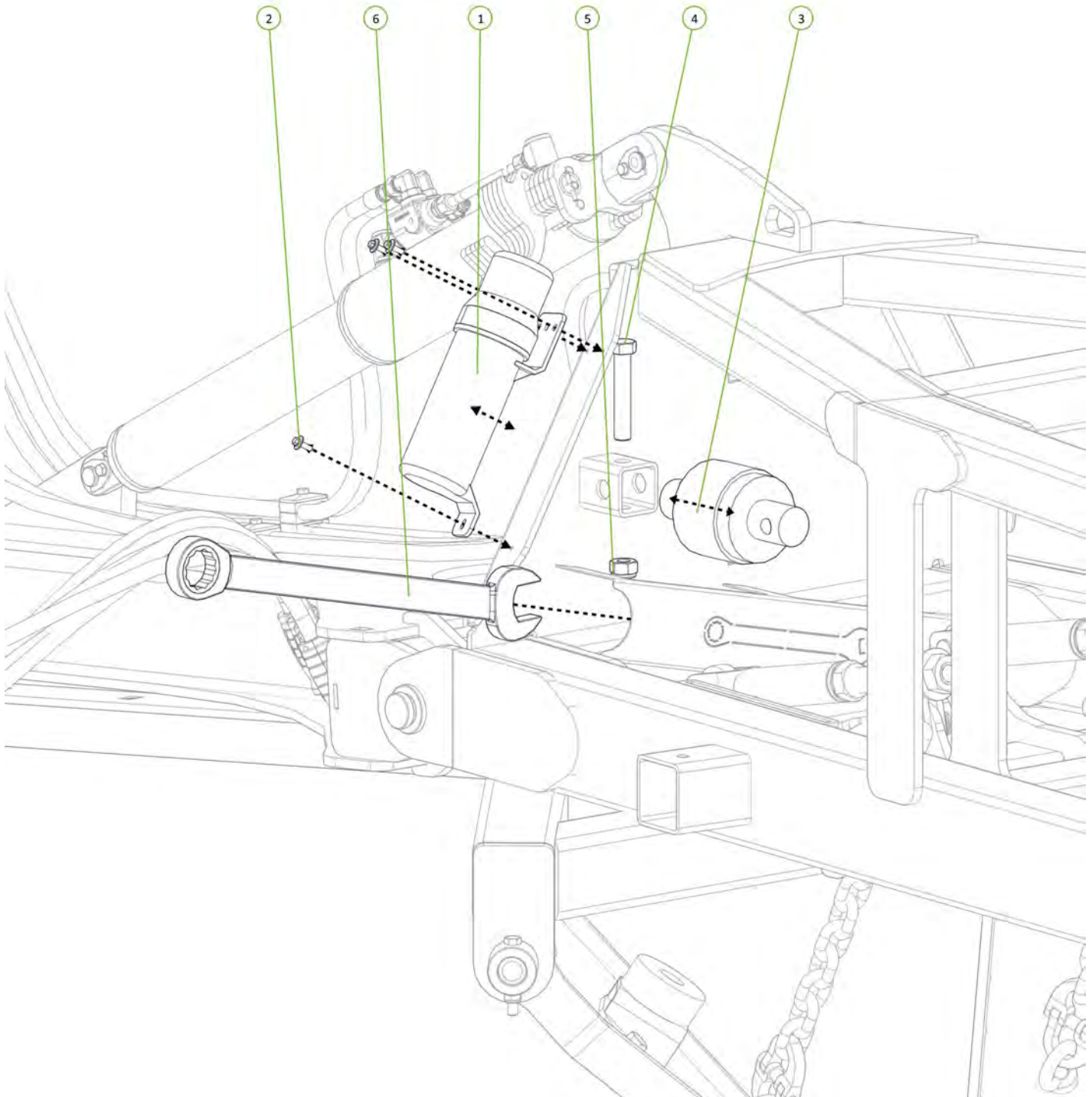
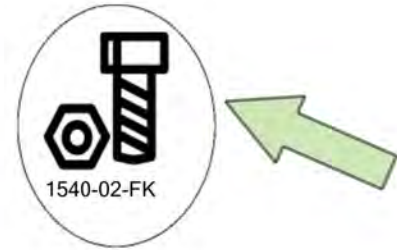

Item No.	Description	Qty	Number
1	Safety Chain Assembly	1	0810-16

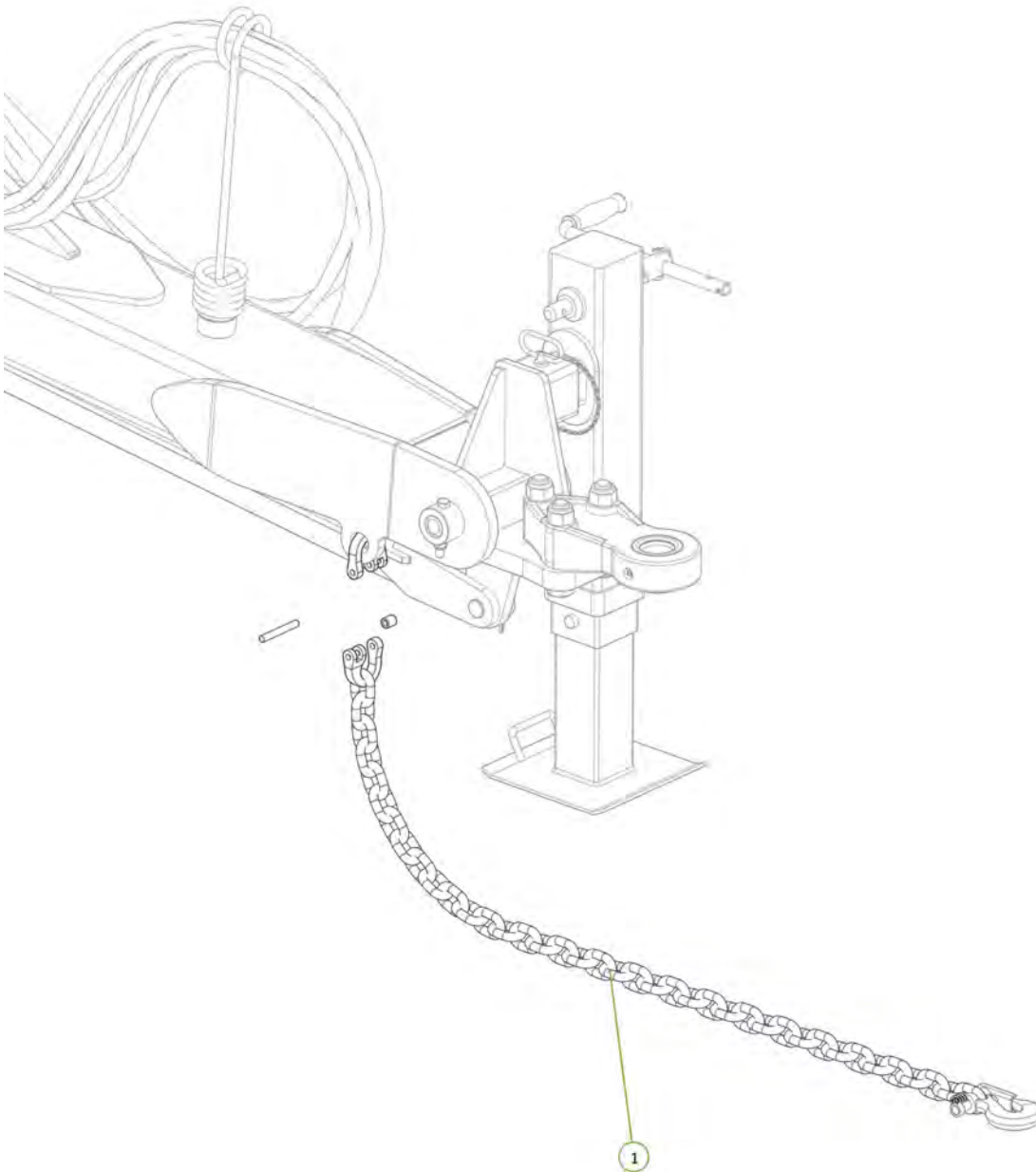

Item No.	Description	Qty	Number
1	Cylinder Safety Stop	1	0800-688
2	Square Loop Pin 5/16" x 3 1/2"	1	0511-PINLOOPSQ516x312

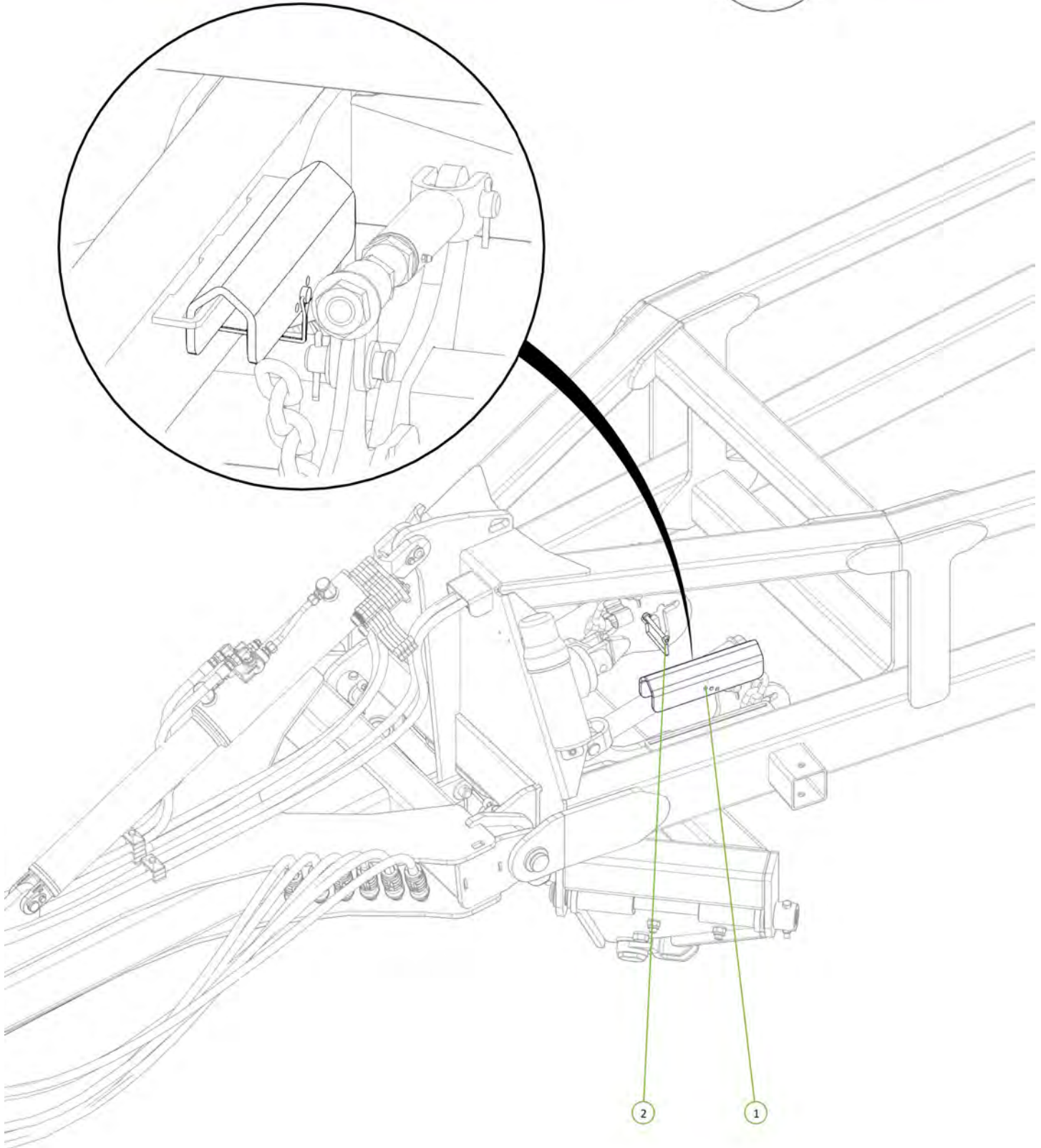

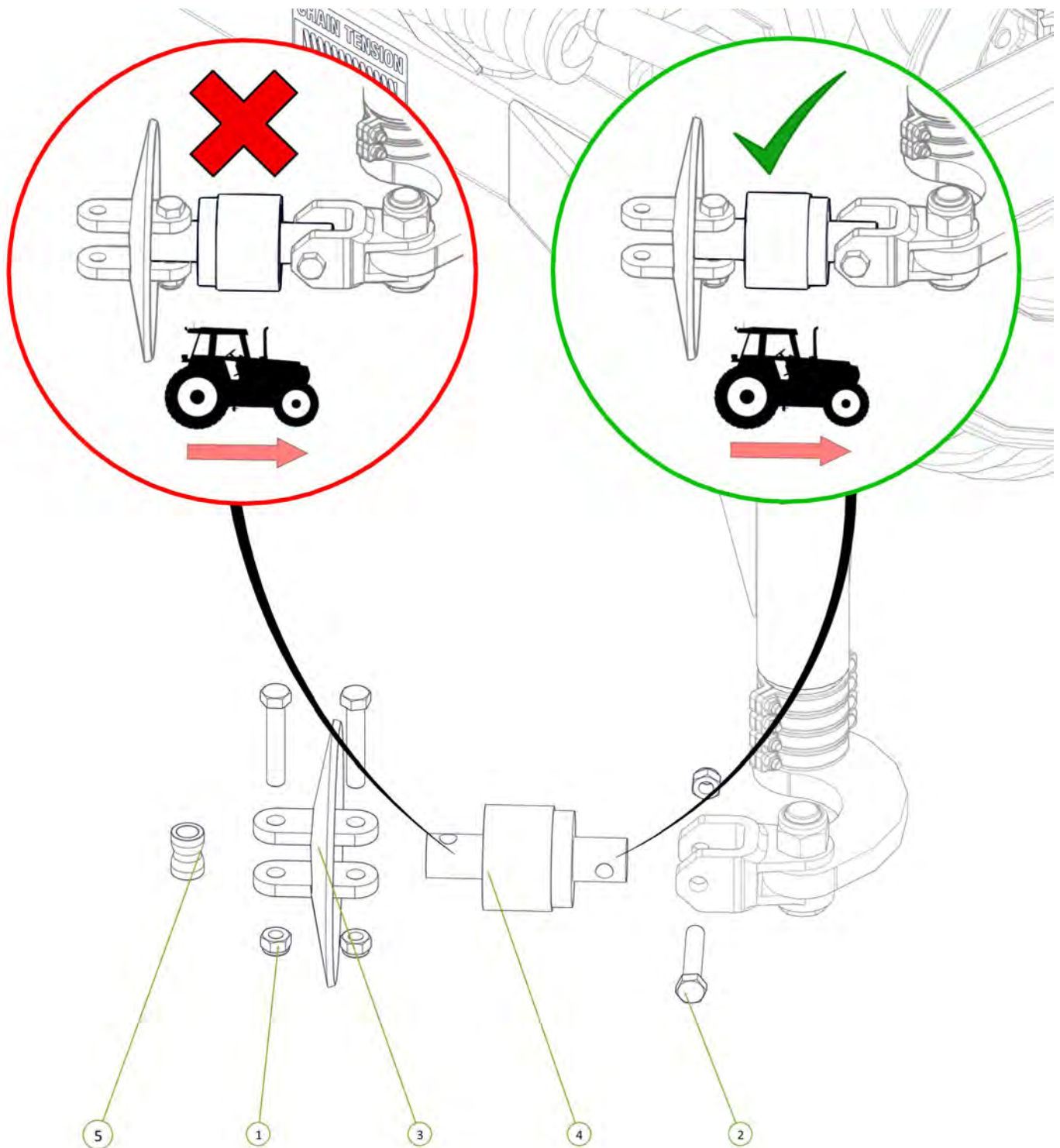

Item No.	Description	Qty	Number
1	Nyloc Nut M20	3	0221-NYL20
2	M20 x 110 grade 10.9 ZP Short Thread Bolt	3	0211-20110 ST
3	Disc Chain Tie Plate Link 20mm	1	0802-DCTP-20
4	20mm Bolt Swivel Unit	1	0802-PCHB55
5	Disc Chain Spacer	1	0801-253755

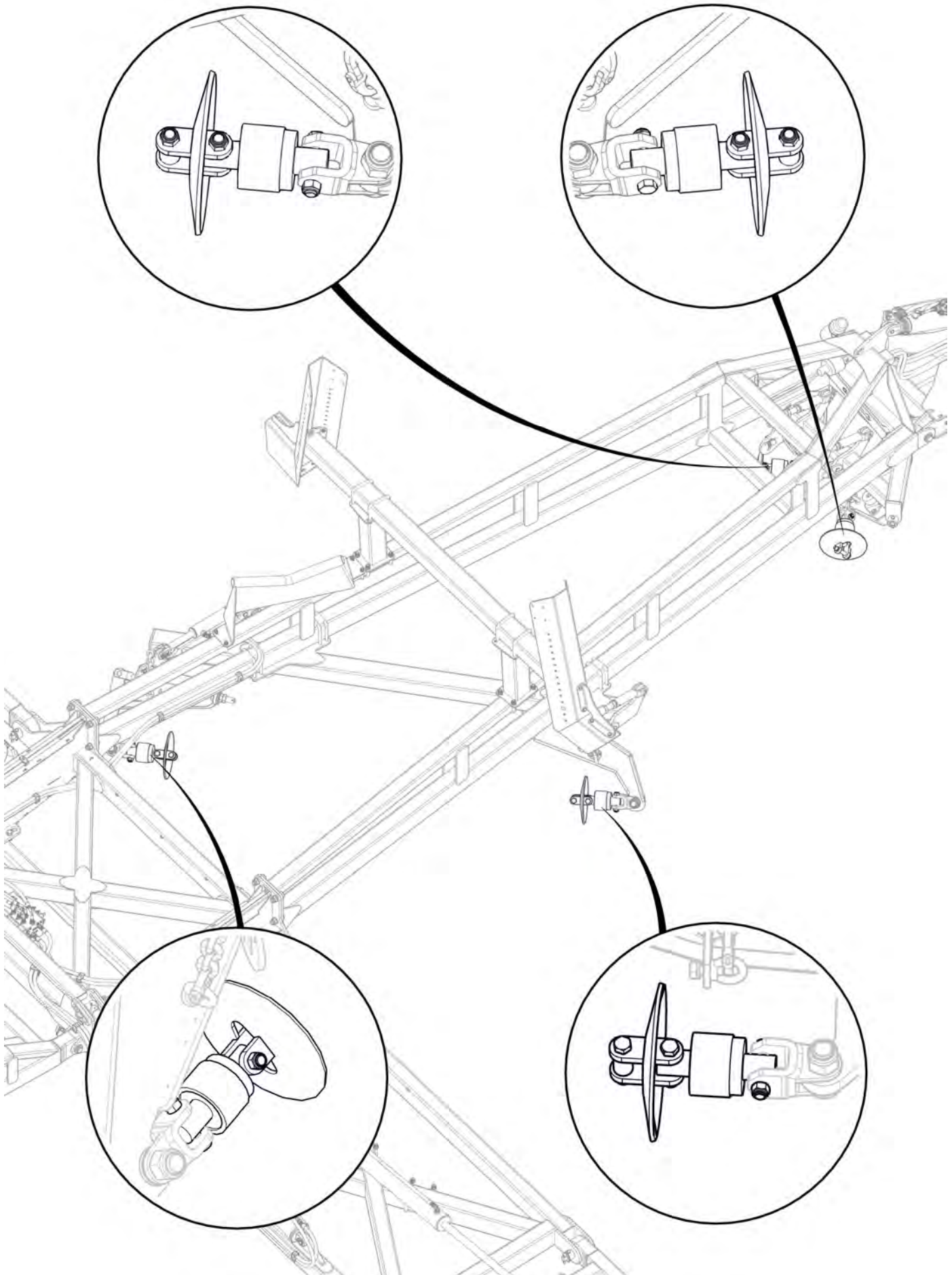

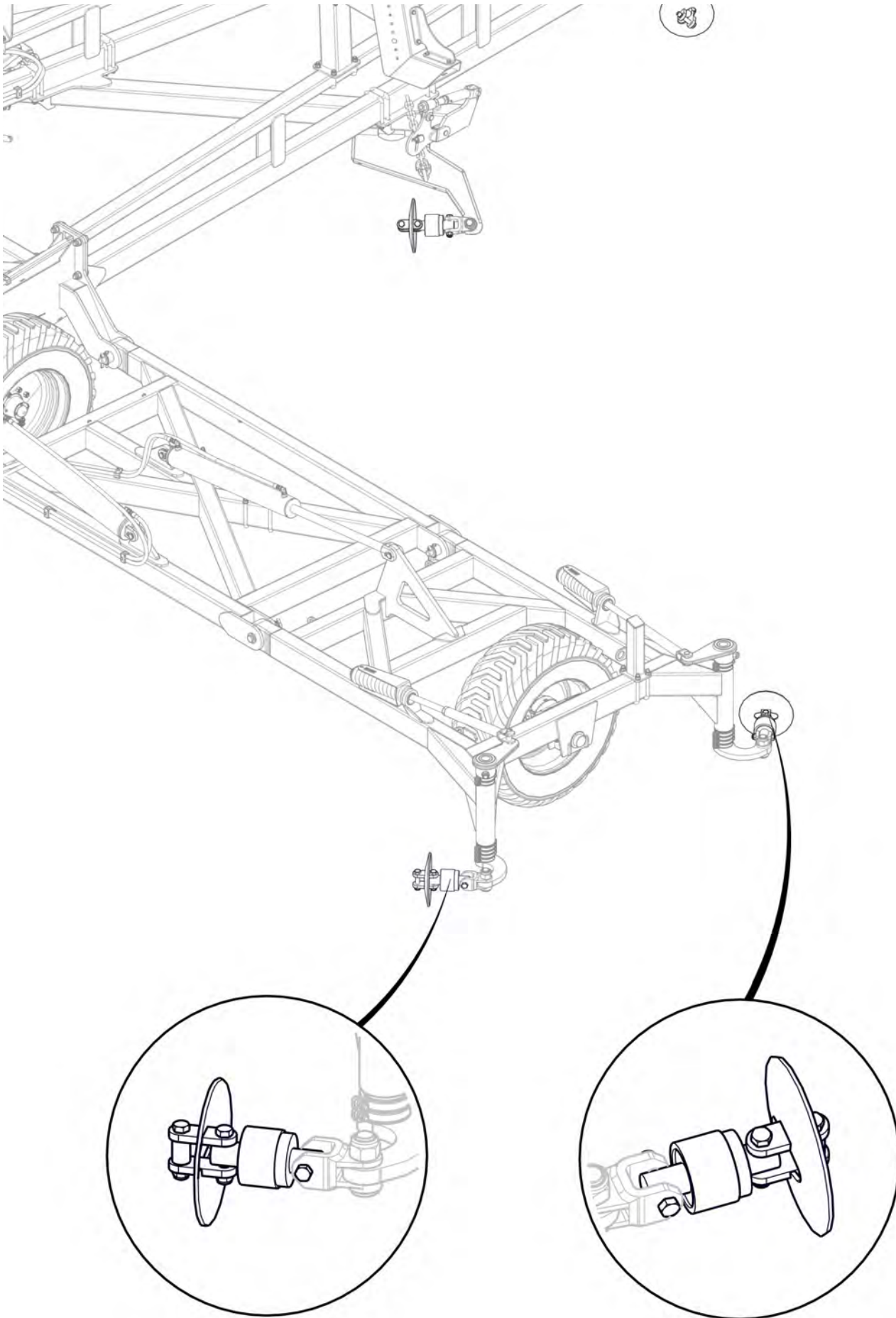

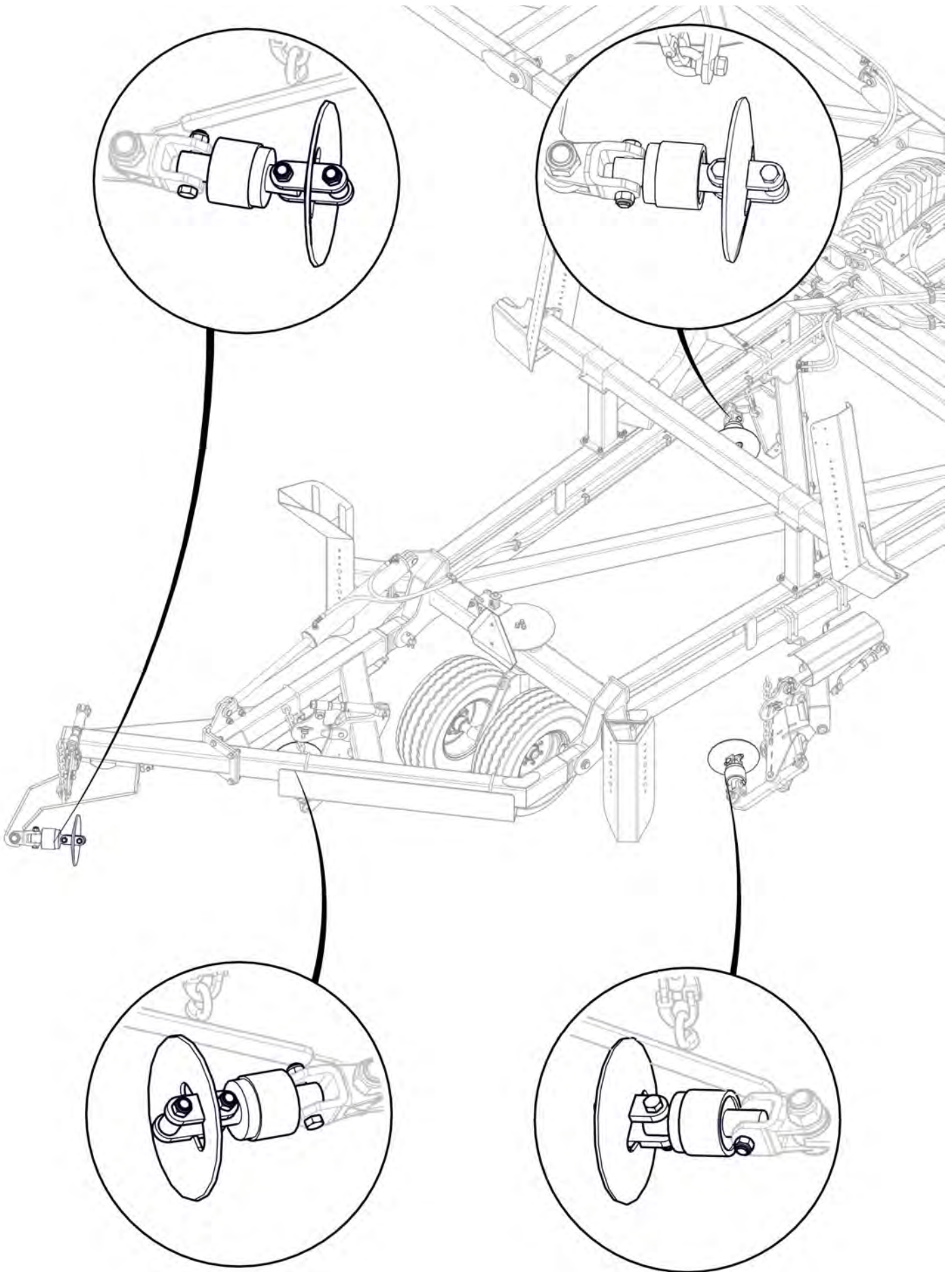

Ensure bearings are correctly orientated with seals facing the rear of the machine

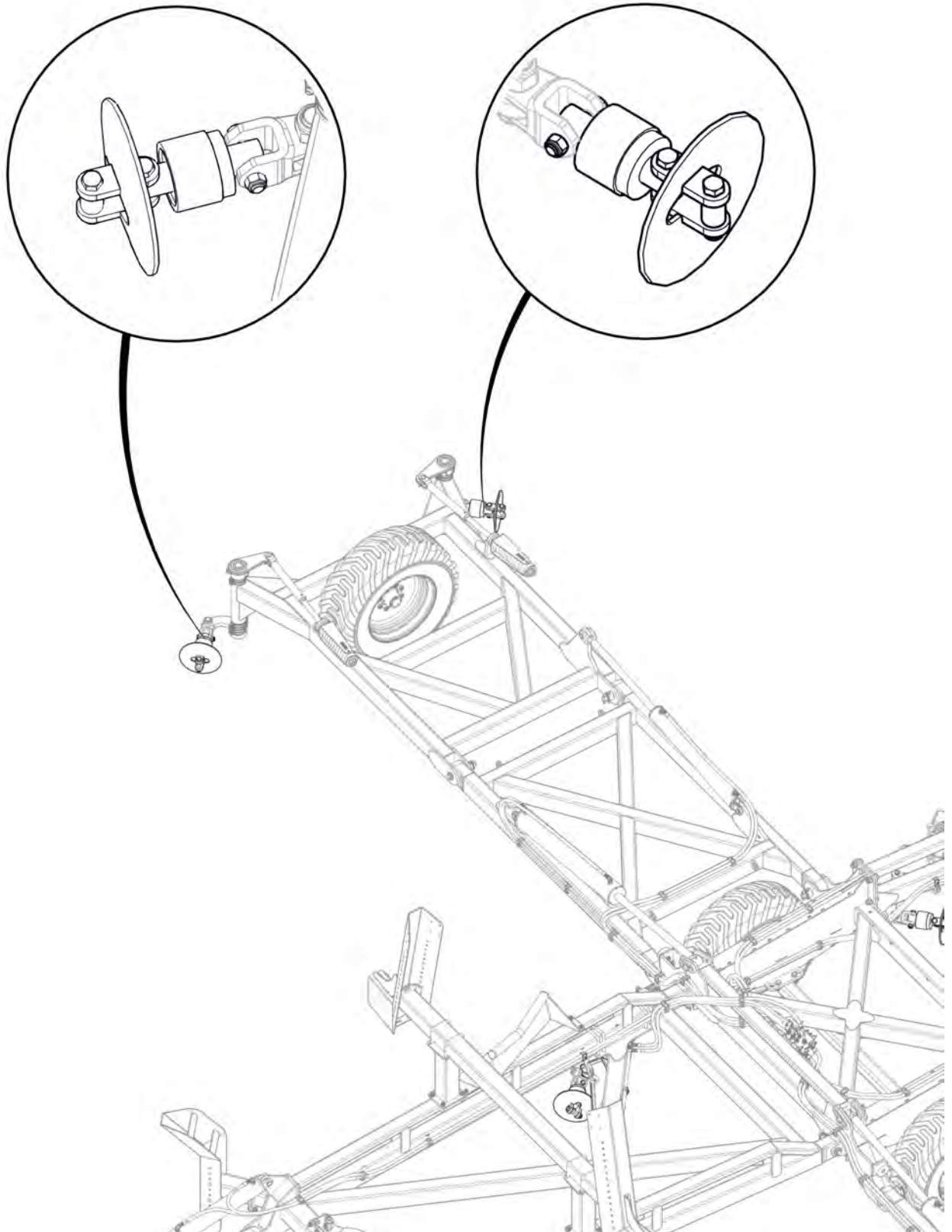

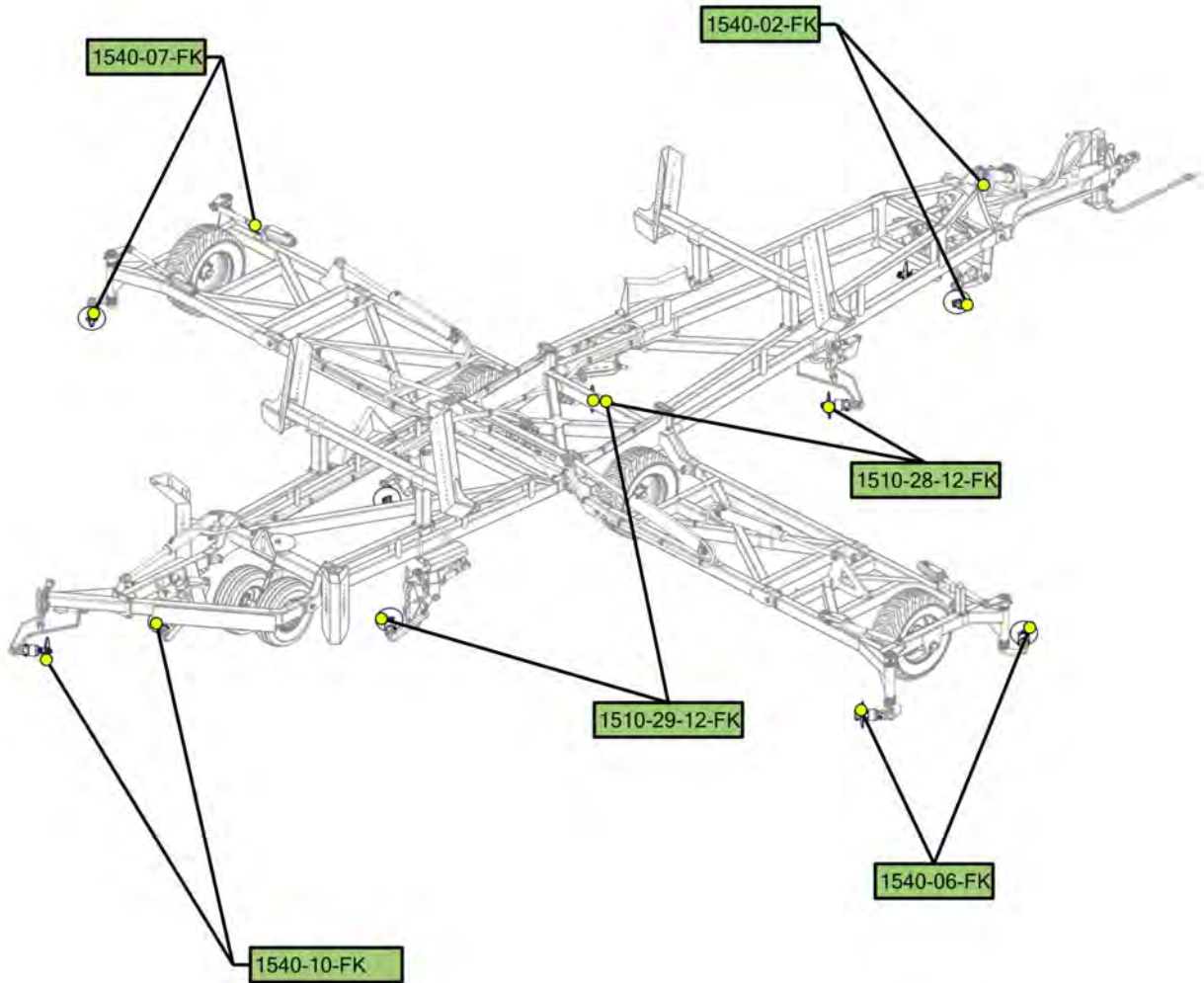

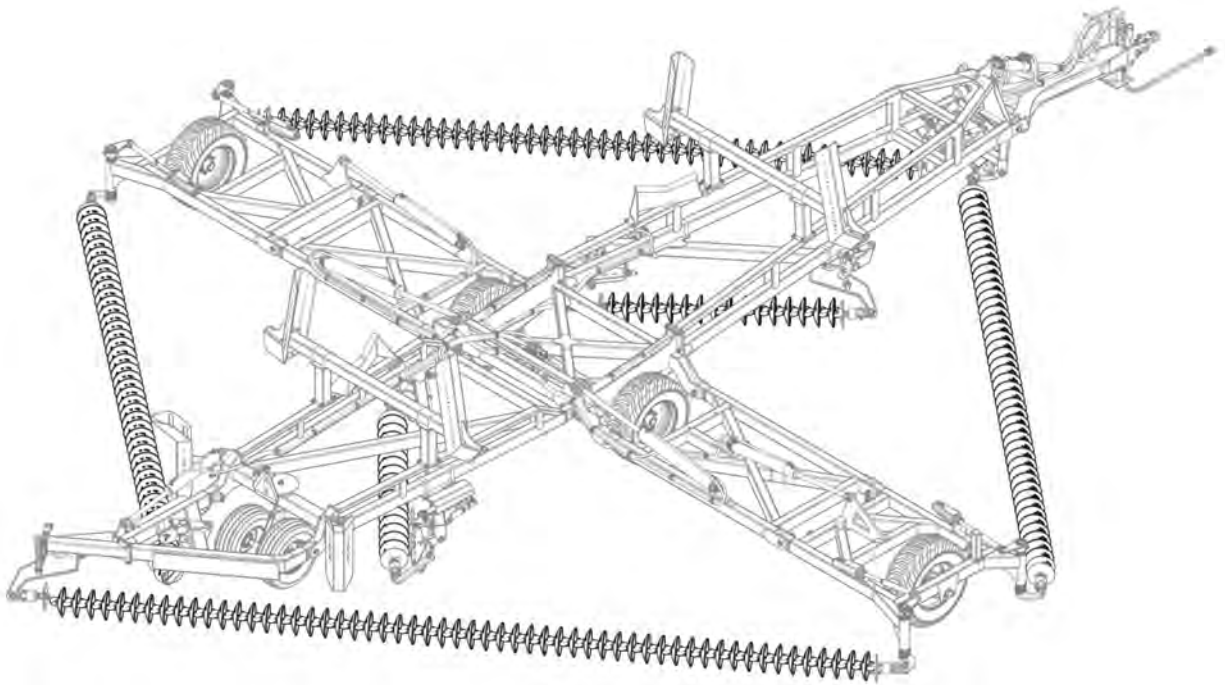



Section 3 - Decal Application

1. **CLEAN**
Wipe application surface and allow to fully dry. Ensure the area is free from dirt and contaminants.
2. **PEEL BACKING**
Carefully peel away paper backing.
3. **ALIGN AND PRESS**
Align the decal and carefully place it on surface.
4. **SMOOTH**
Use a squeegee to smooth design over surface, from top to bottom and to push out all remaining air. Ensure full coverage with no bubbles.

For the Kelly Harrow 3009 Decal (0801-SKT3009), follow this instructions below:

1. **CLEAN**
Wipe application surface and allow to fully dry. Ensure the area is free from dirt, and contaminants.
2. **PEEL BACKING**
Carefully peel away paper backing, ensuring vinyl sticks entirely to tape.
3. **ALIGN AND PRESS**
Align the decal and carefully place it on surface.
4. **SMOOTH**
Use a squeegee to smooth design over surface, from top to bottom and to push out all remaining air. Ensure full coverage with no bubbles.
5. **REMOVE TRANSFER TAPE**
Carefully peel away the transfer tape, beginning at the corner until completely removed. Finally, allow decal to cure for 24 hours before washing.

For the Fold/Unfold Decal (0801-S1), follow this instructions below:

1. **CLEAN**
Wipe application surface and allow to fully dry. Ensure the area is free from dirt and contaminants.
2. **APPLY SOLUTION**
Using detergent wet the surface where you'll be applying the decal so you can slide it around.
3. **PEEL BACKING**
Carefully peel away paper backing.
4. **ALIGN AND PRESS**
Align the decal and carefully place it on surface.
5. **SMOOTH**
Use a squeegee to smooth design over surface, from center to corners and to push out all remaining air. Ensure full coverage with no bubbles.

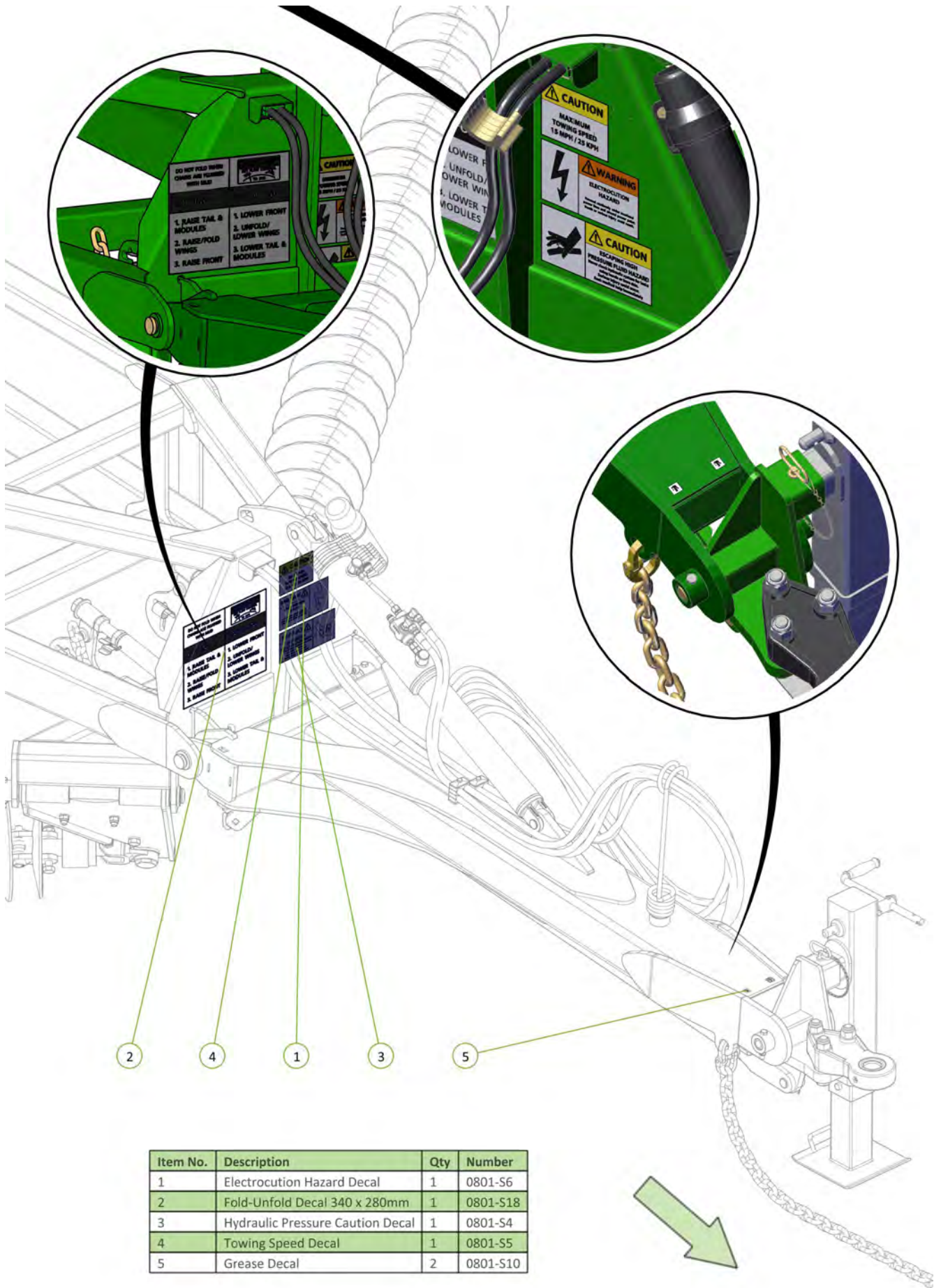

Item No.	Description	Qty	Number
1	Electrocution Hazard Decal	1	0801-S6
2	Fold-Unfold Decal 340 x 280mm	1	0801-S18
3	Hydraulic Pressure Caution Decal	1	0801-S4
4	Towing Speed Decal	1	0801-S5
5	Grease Decal	2	0801-S10

Item no.	Description	Qty	Number
1	Kelly Tillage Data Plate	1	0801-SKTDP
2	Universal Patent Decal	1	0801-S26

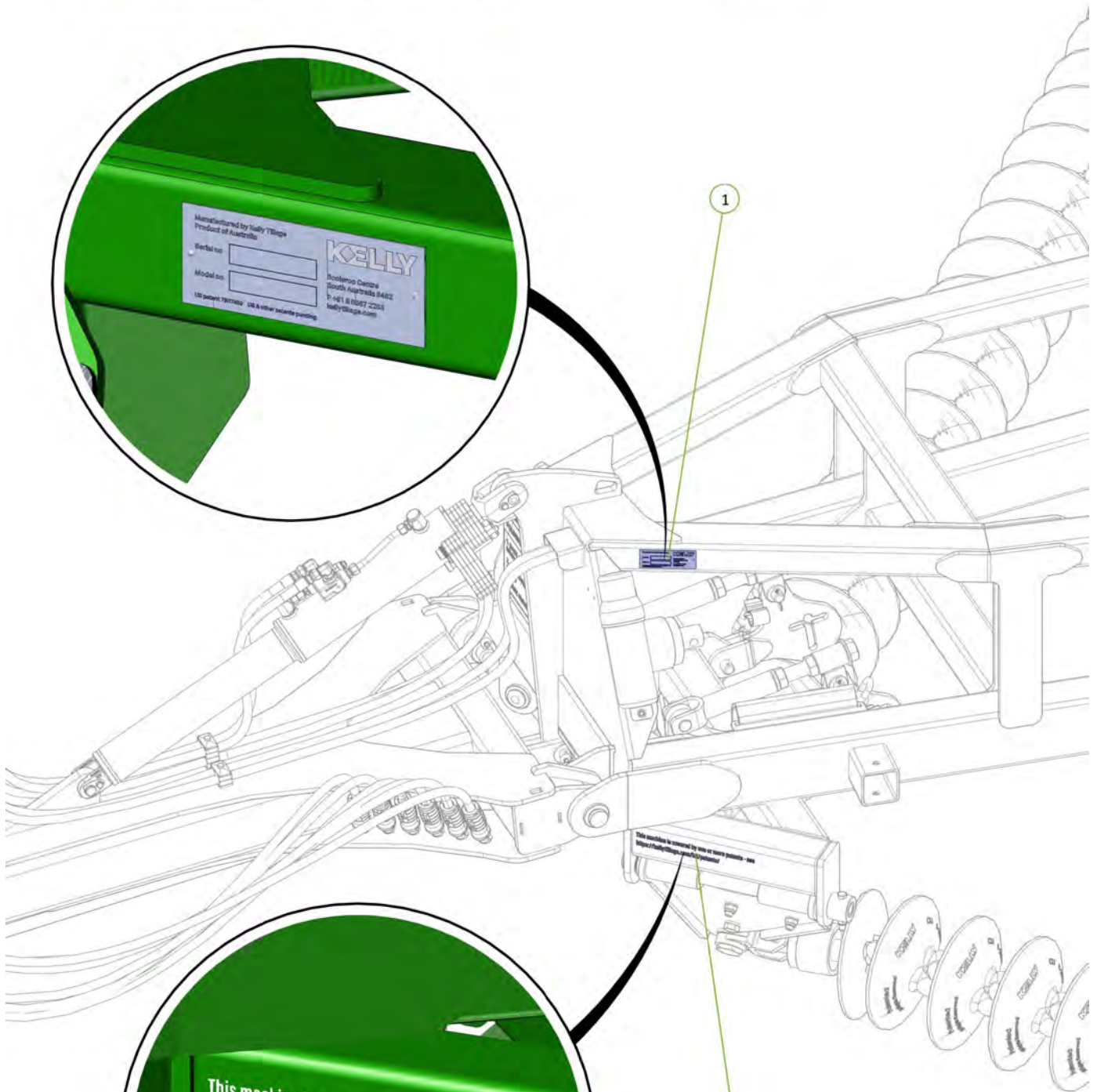

Item No.	Description	Qty	Number
1	Kelly Tillage Decal	2	0801-S24

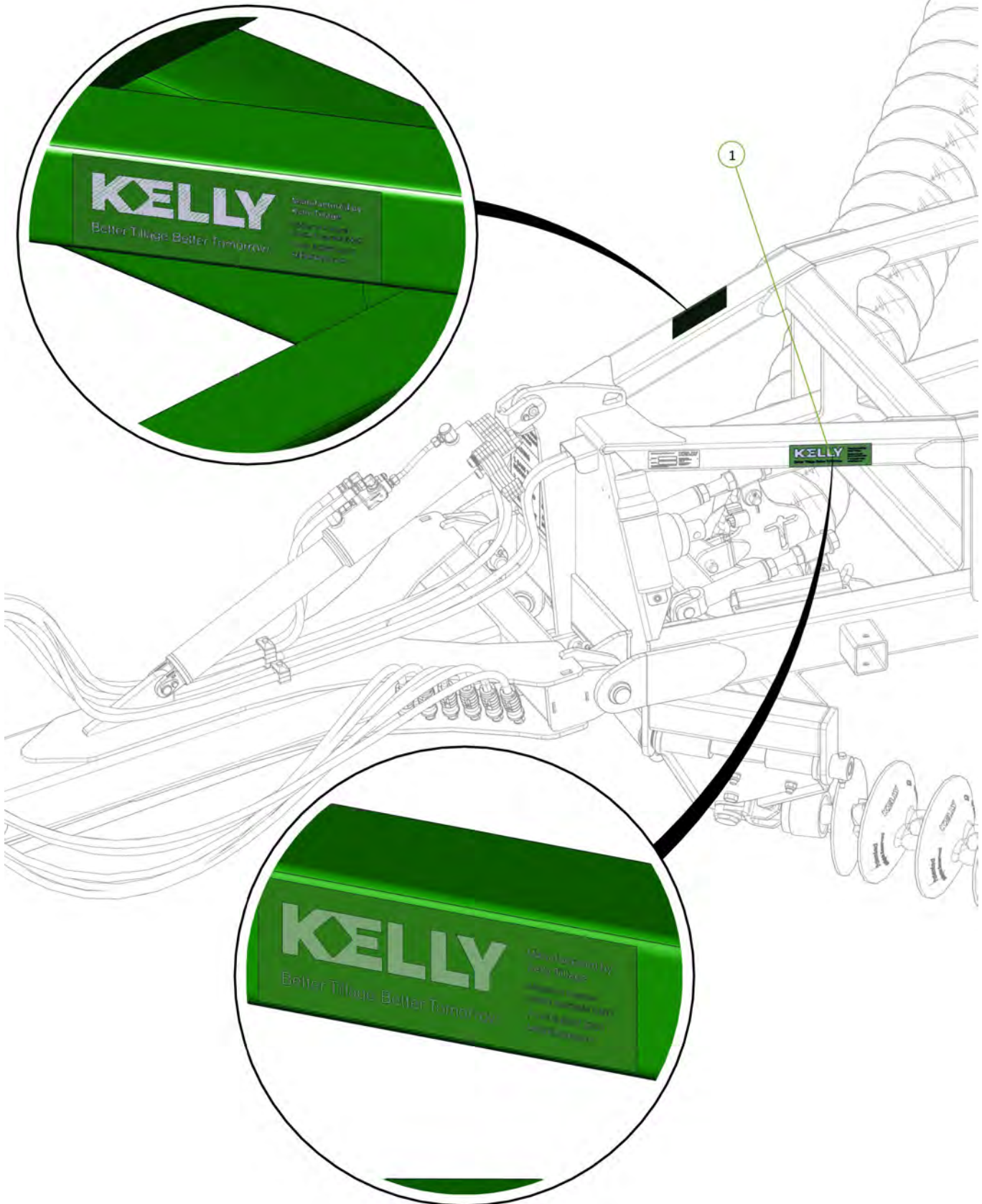

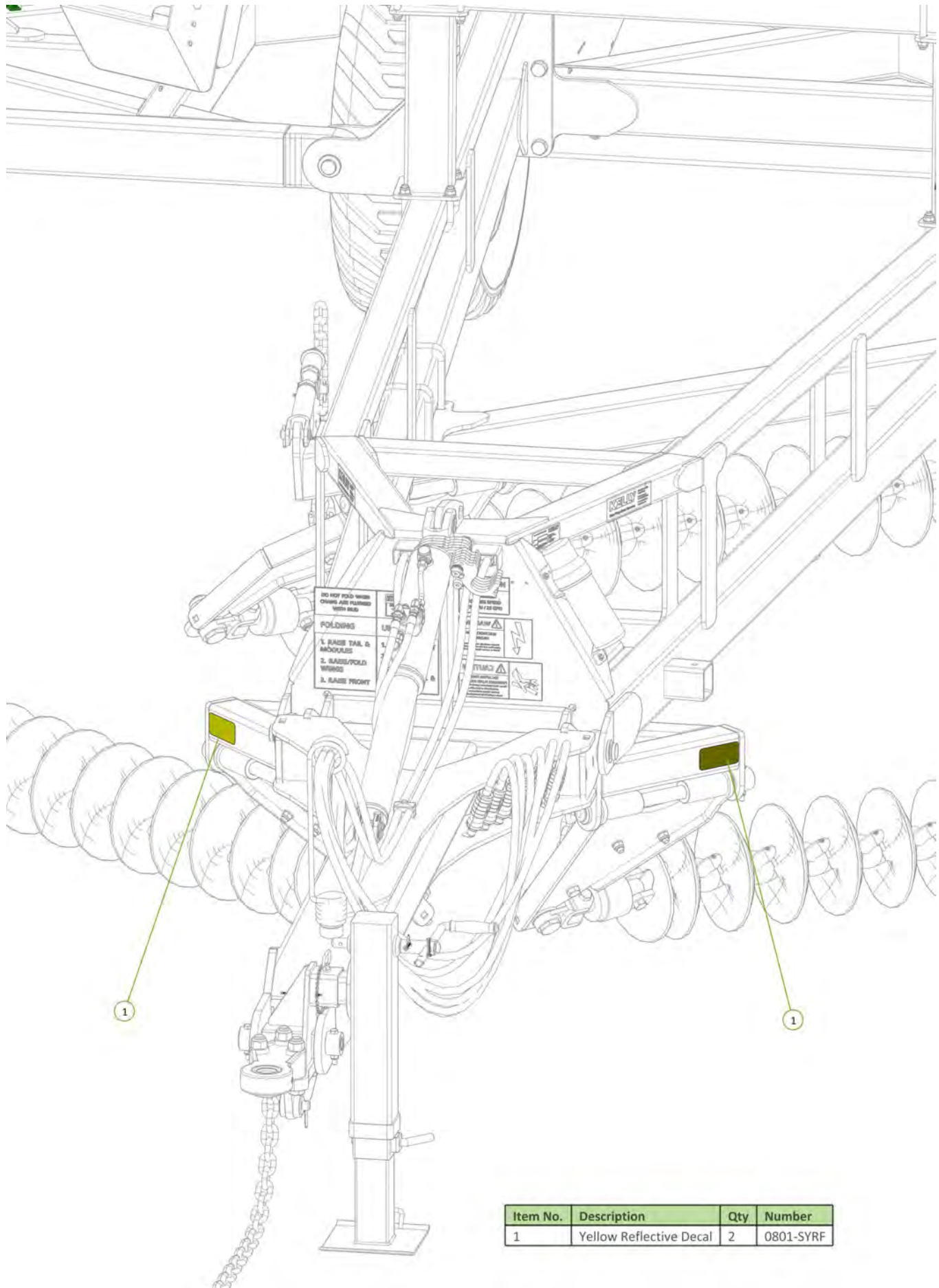

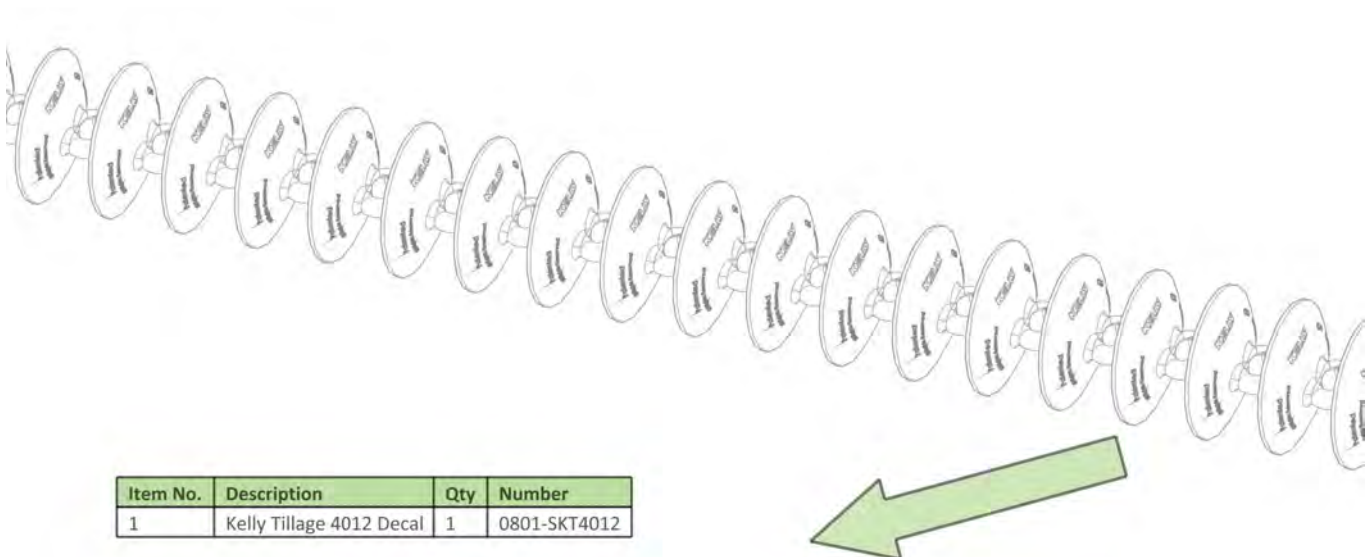
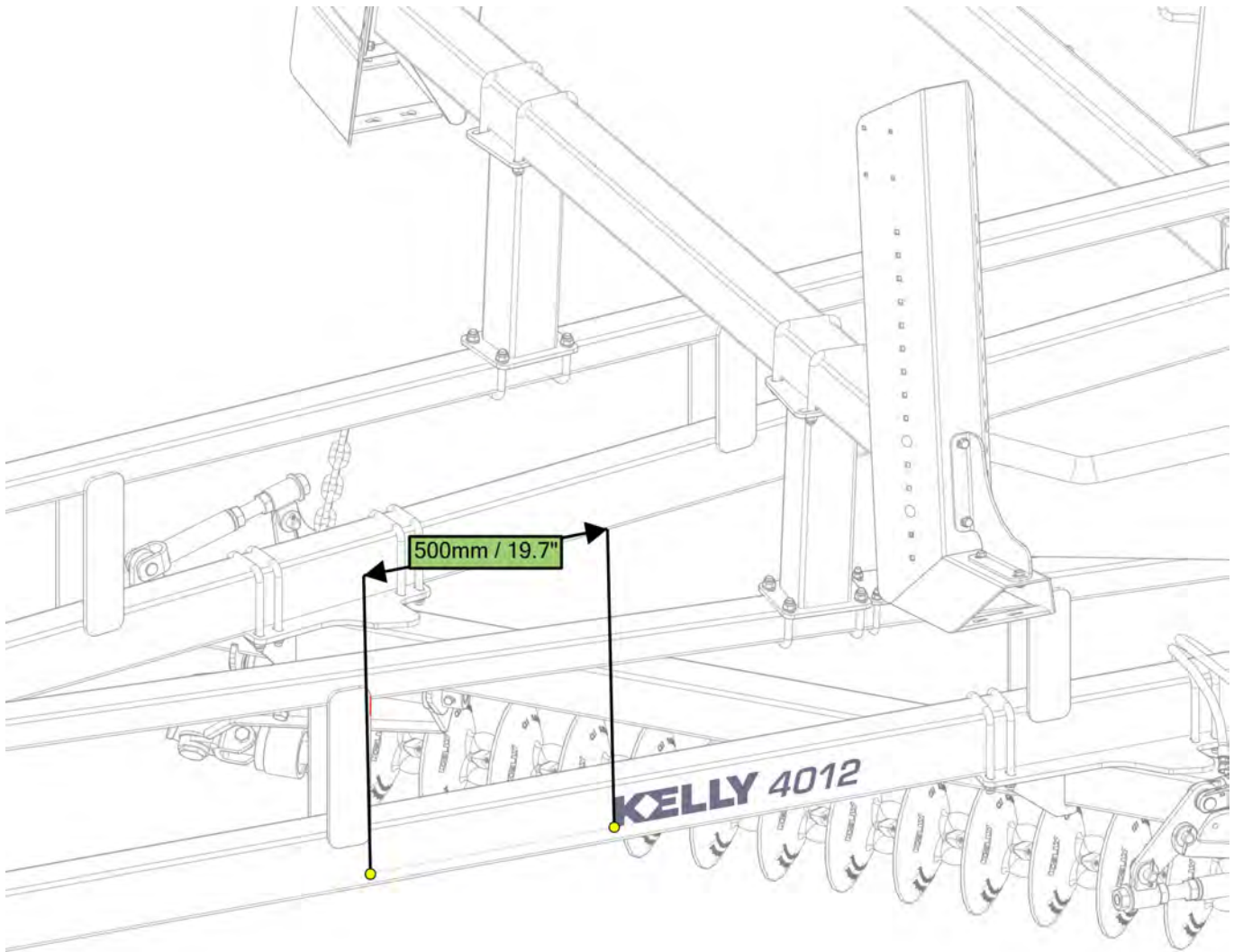

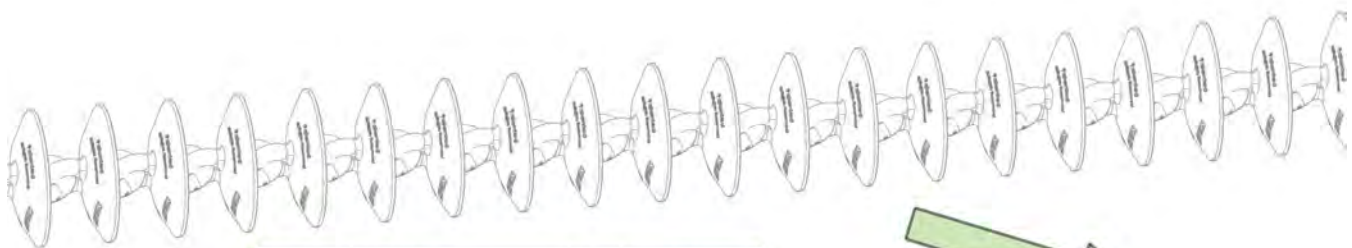
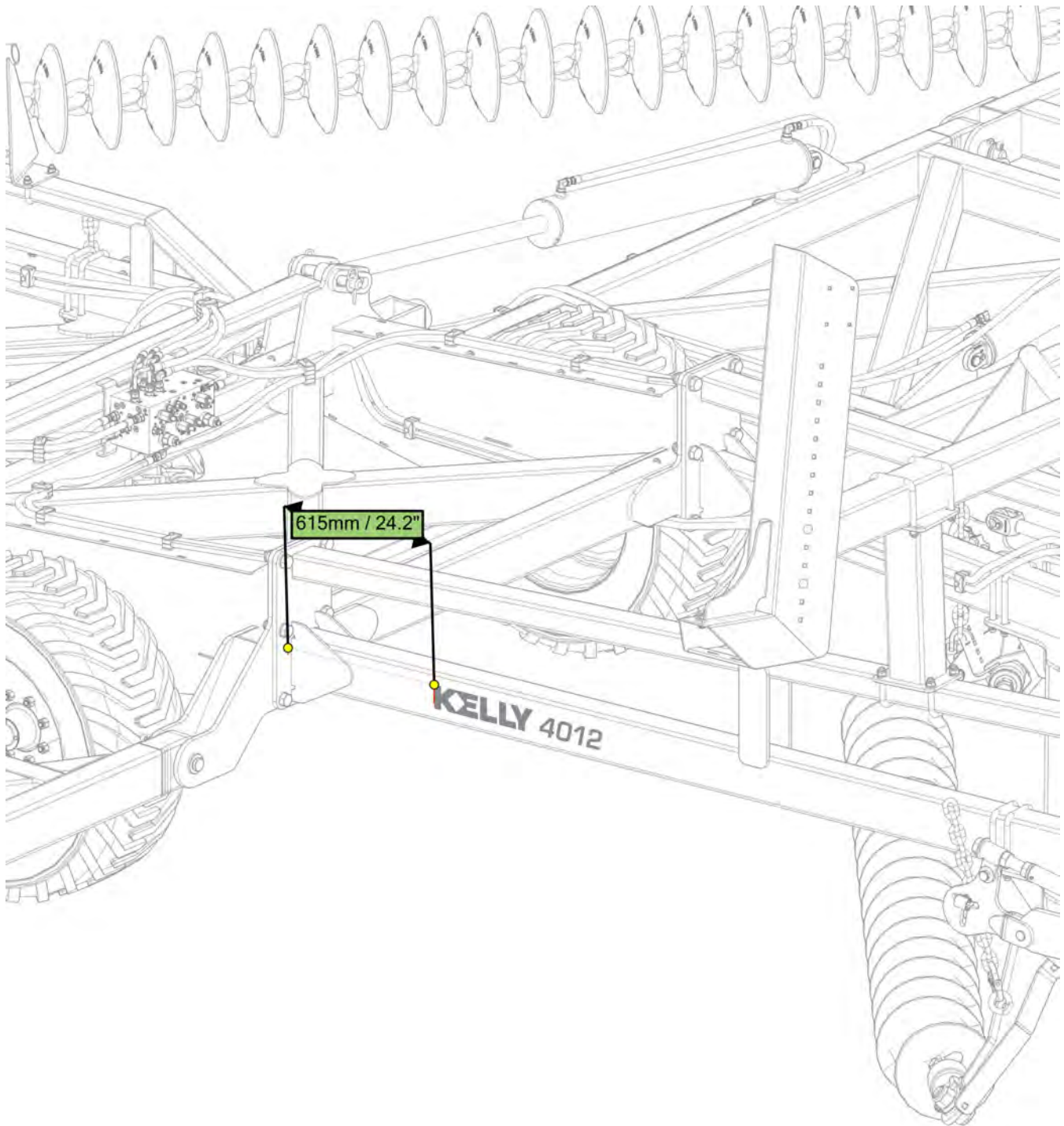

Item No.	Description	Qty	Number
1	Kelly Tillage 4012 Decal	1	0801-SKT4012

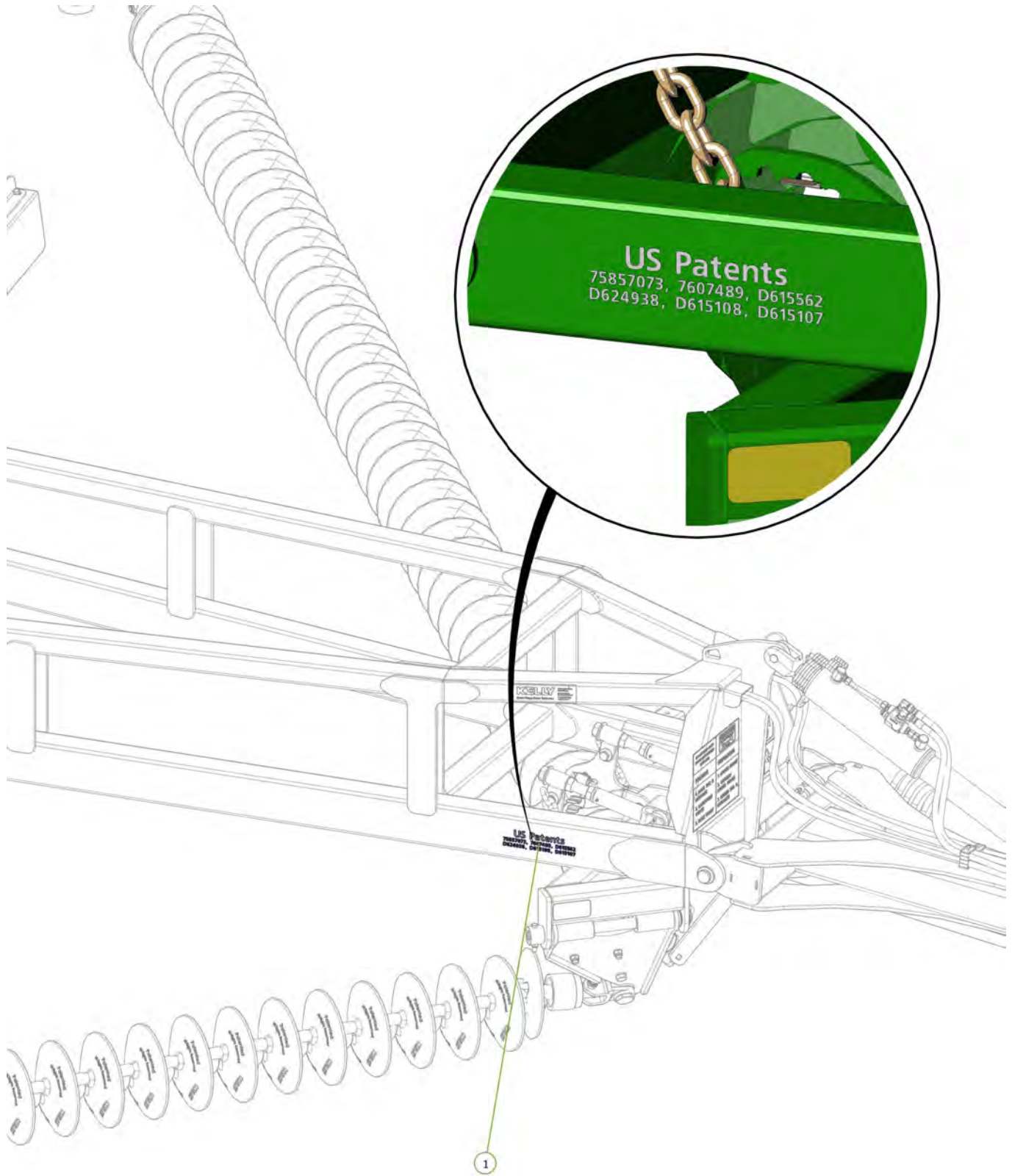

Item No.	Description	Qty	Number
1	USA Patent No. Decal	1	0801-SUSP



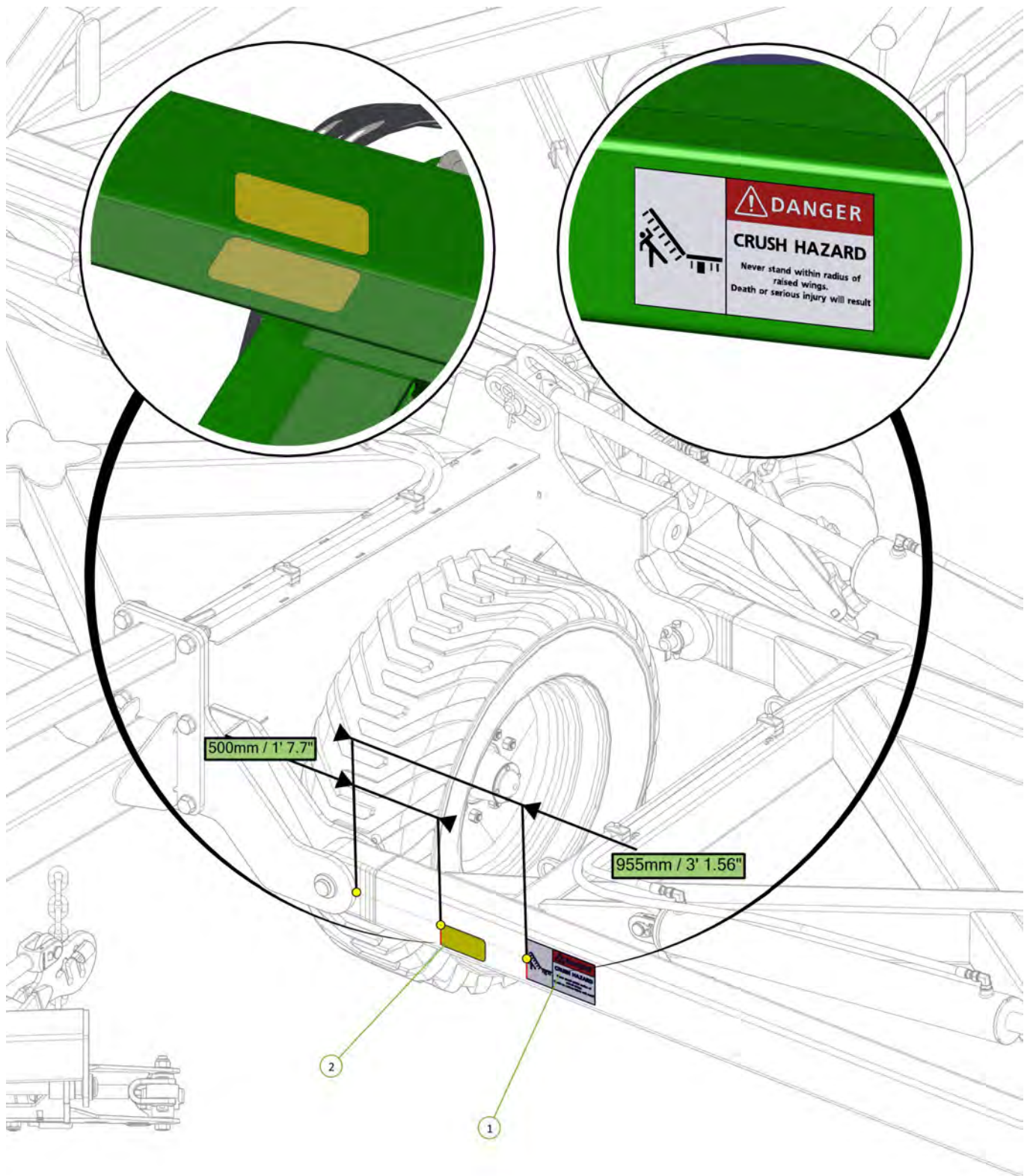

Item No.	Description	Qty	Number
1	Danger Crush Hazard Decal	1	0801-S3
2	Yellow Reflective Decal	2	0801-SYRF



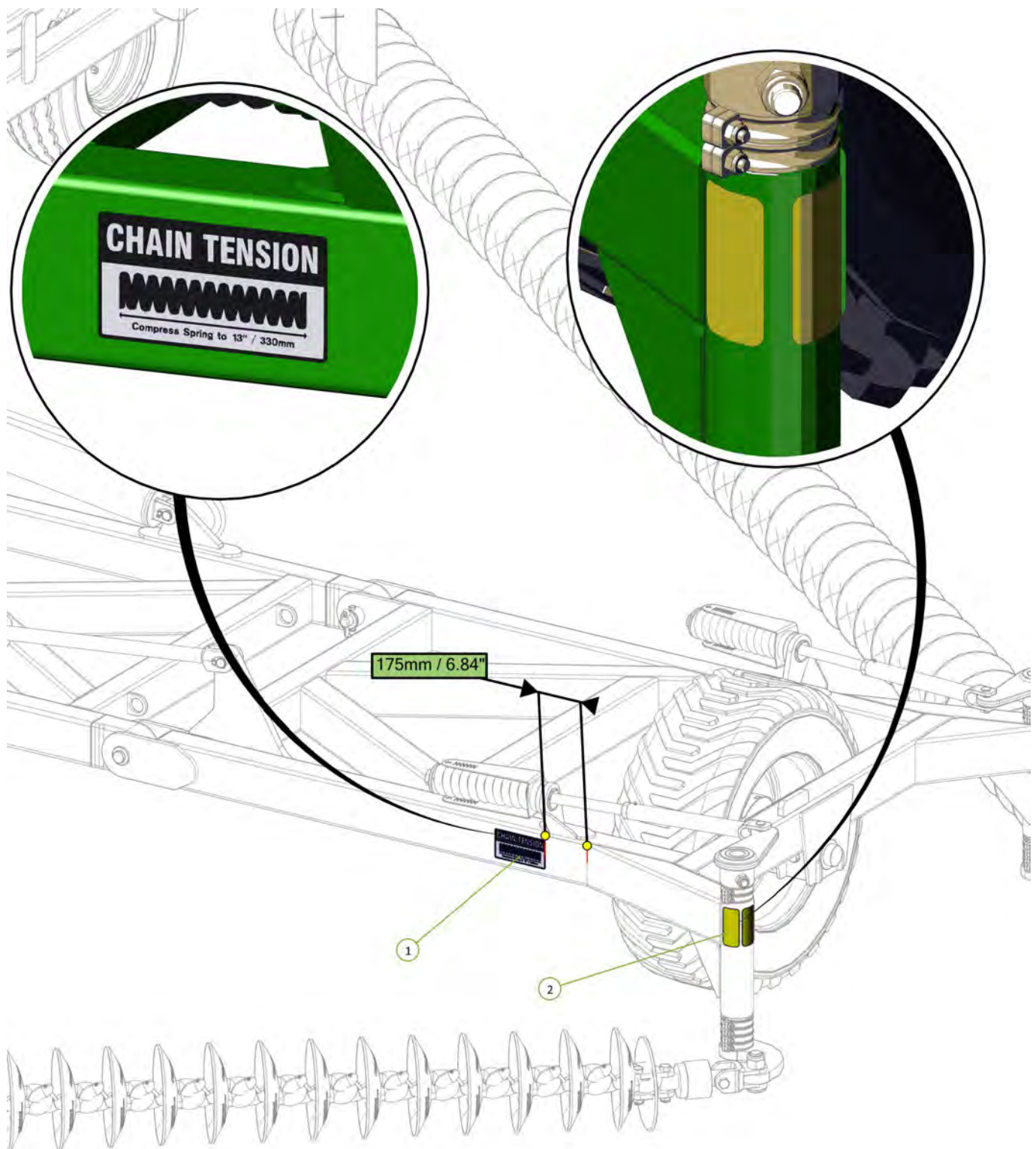

Item No.	Description	Qty	Number
1	Chain Tension 330mm Decal	1	0801-S15
2	Yellow Reflective Decal	2	0801-SYRF



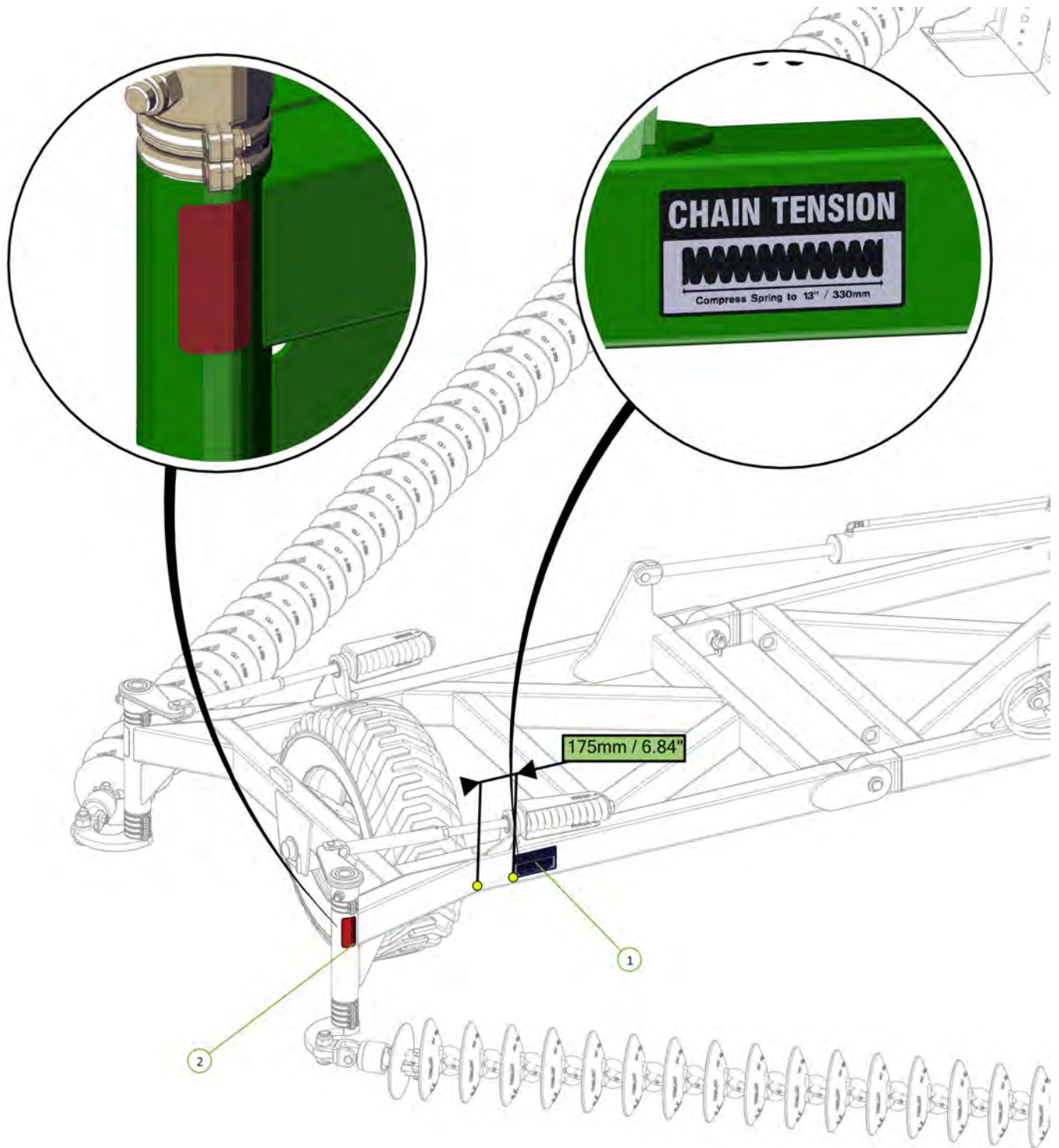

Item No.	Description	Qty	Number
1	Chain Tension 330mm Decal	1	0801-S15
2	Red Reflective Decal	1	0801-SRRF



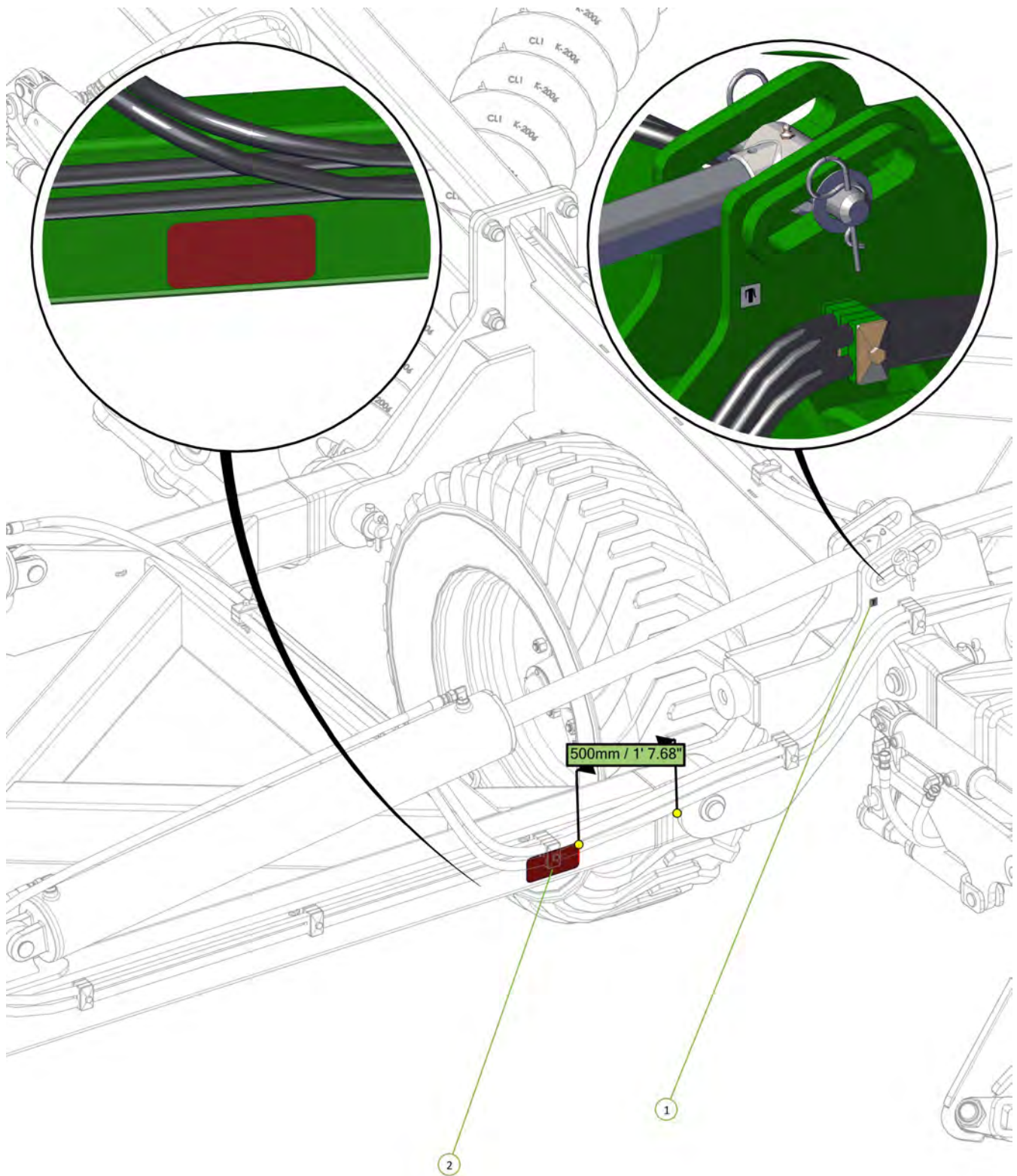

Item No.	Description	Qty	Number
1	Grease Decal	1	0801-S10
2	Red Reflective Decal	1	0801-SRRF

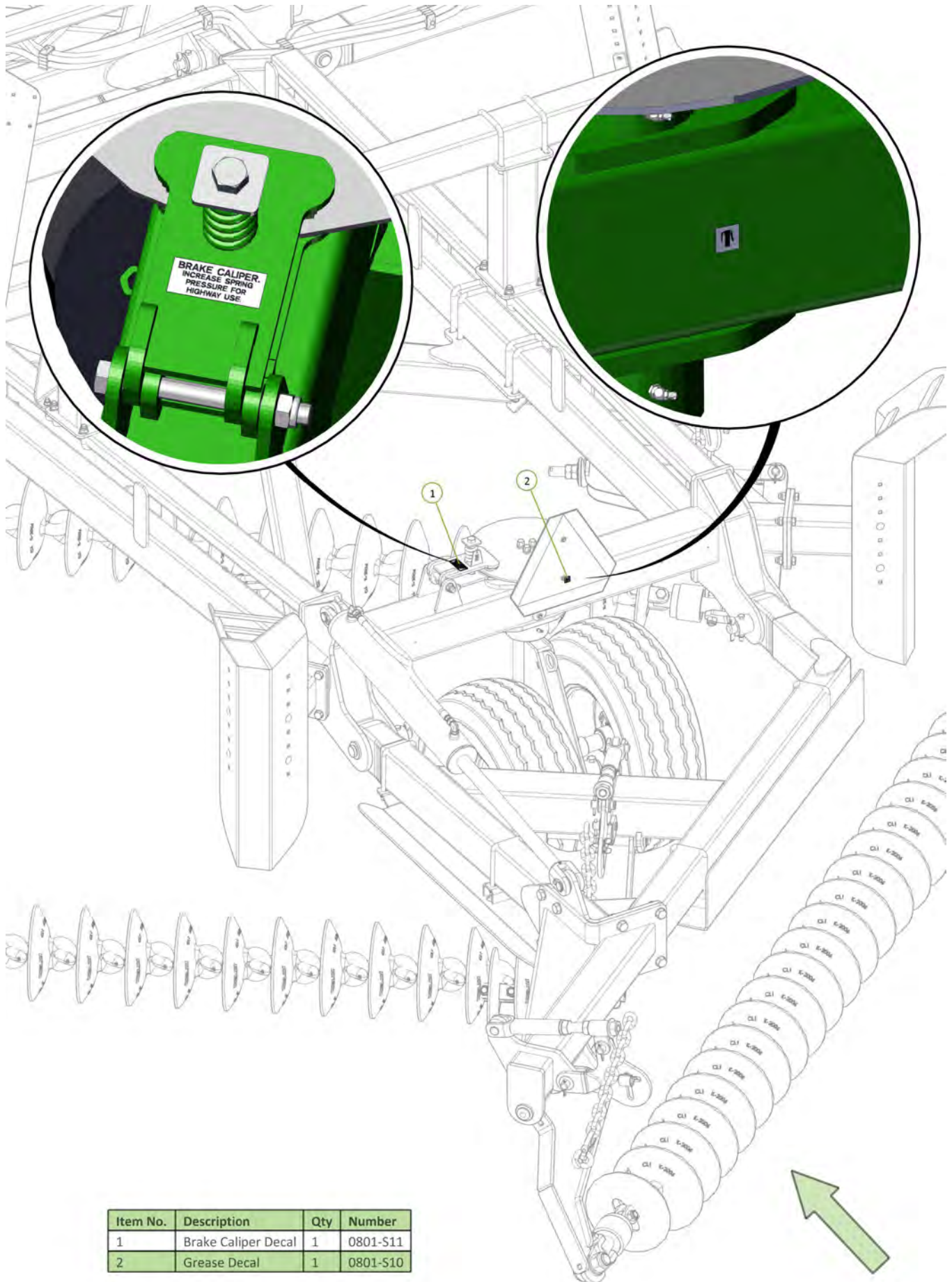

Item No.	Description	Qty	Number
1	Brake Caliper Decal	1	0801-S11
2	Grease Decal	1	0801-S10

Item No.	Description	Qty	Number
1	Yellow Reflective Decal	1	0801-SYRF

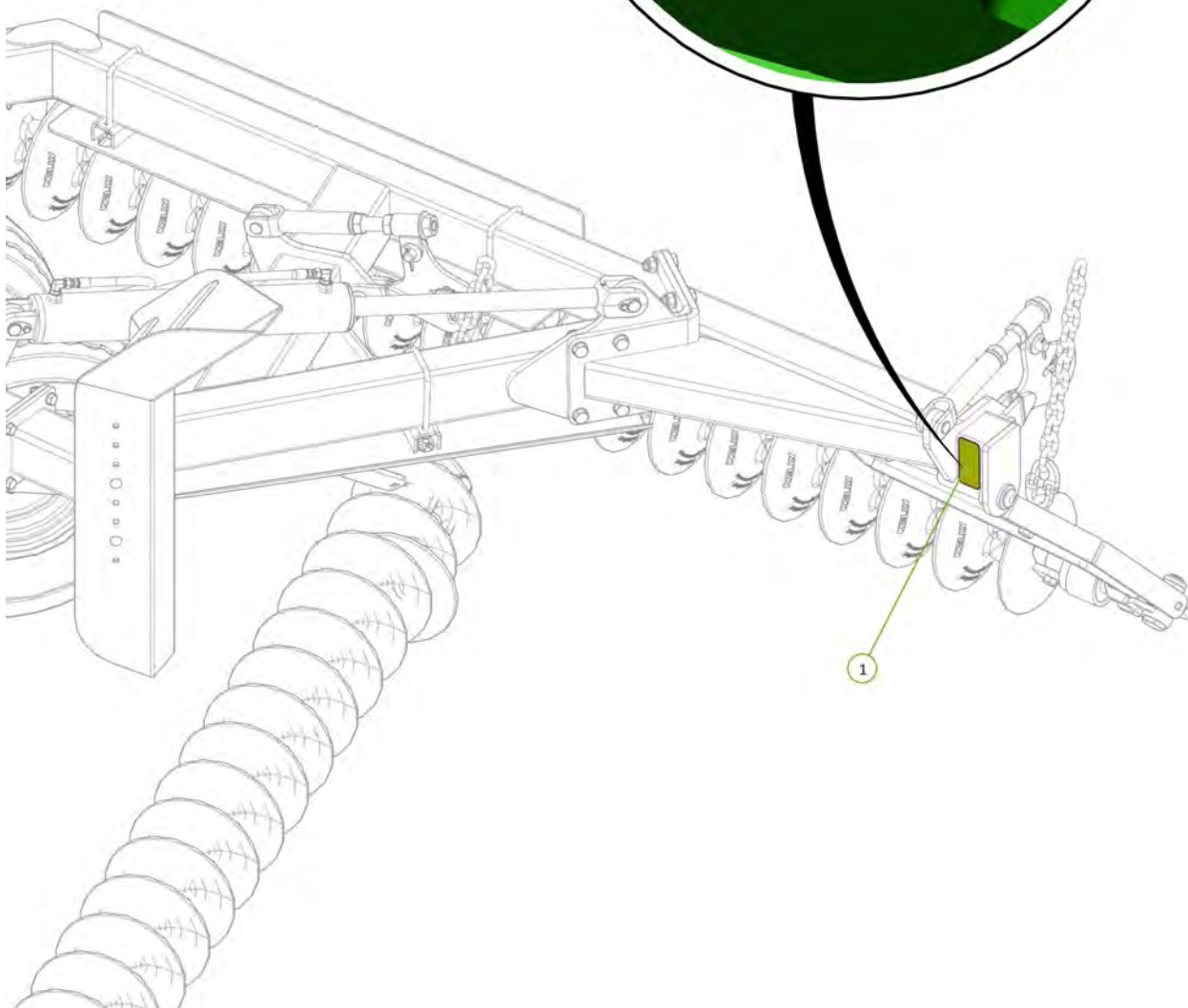

Item No.	Description	Qty	Number
1	Yellow Reflective Decal	1	0801-SYRF

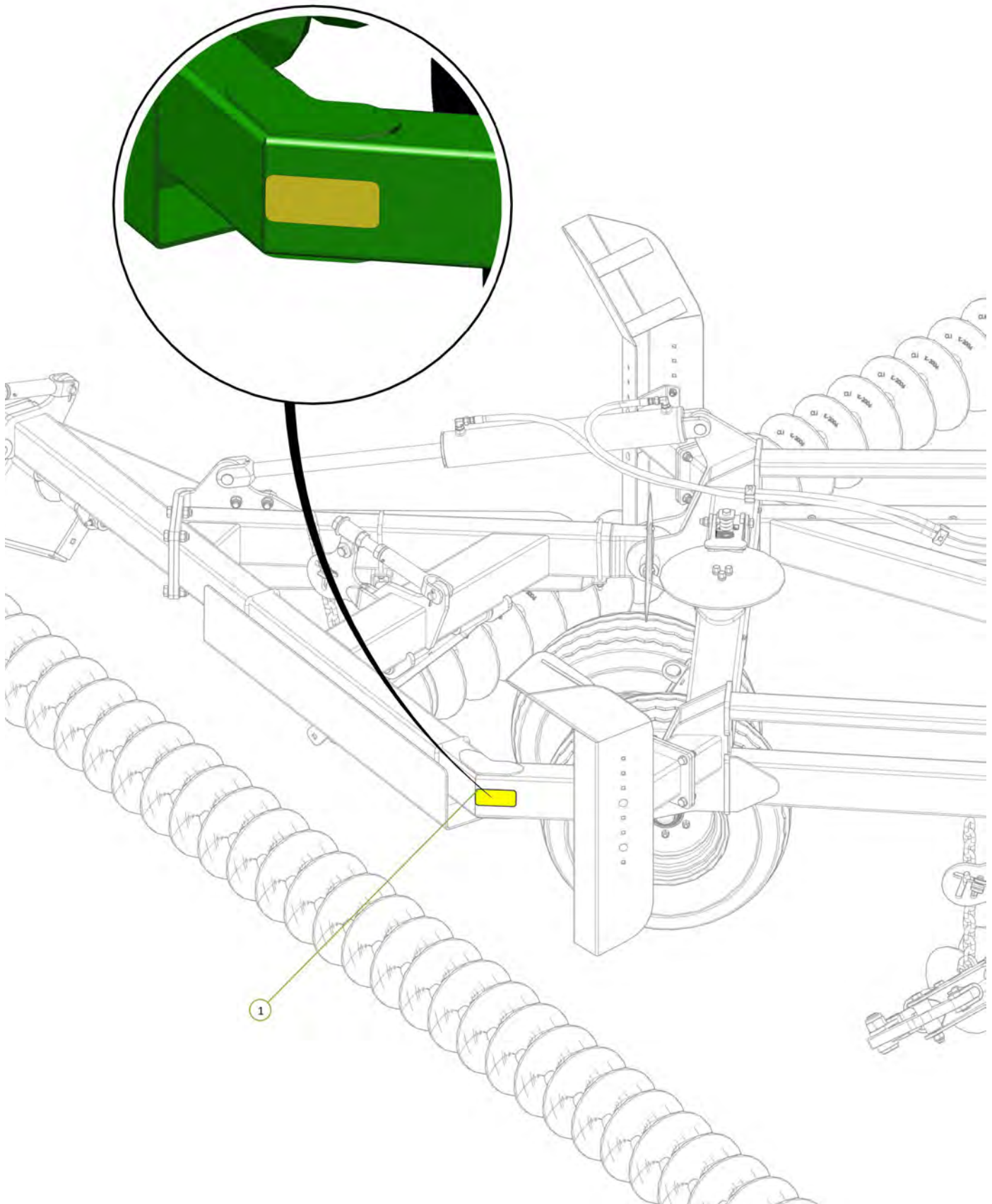

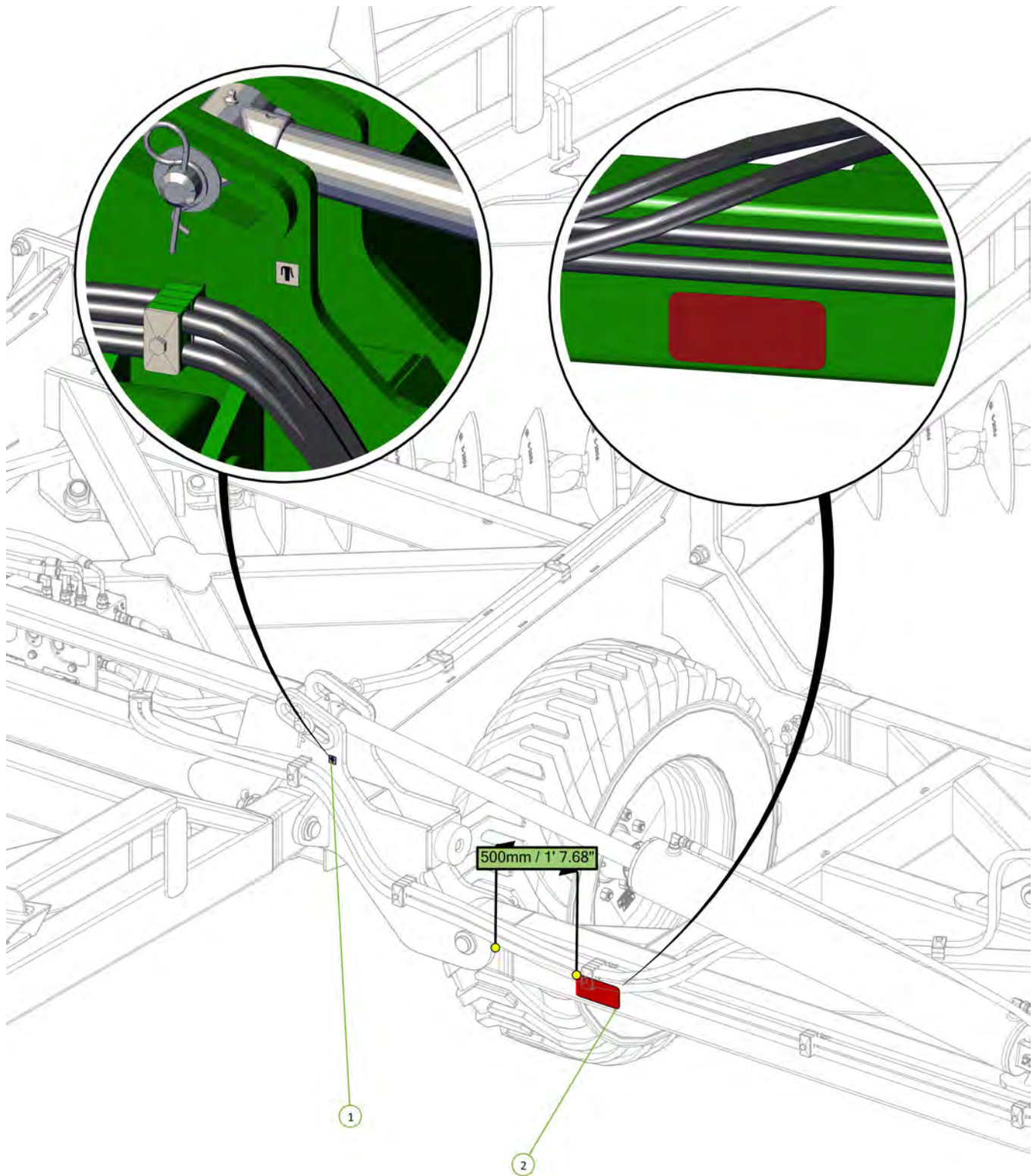

Item No.	Description	Qty	Number
1	Grease Decal	1	0801-S10
2	Red Reflective Decal	1	0801-SRRF



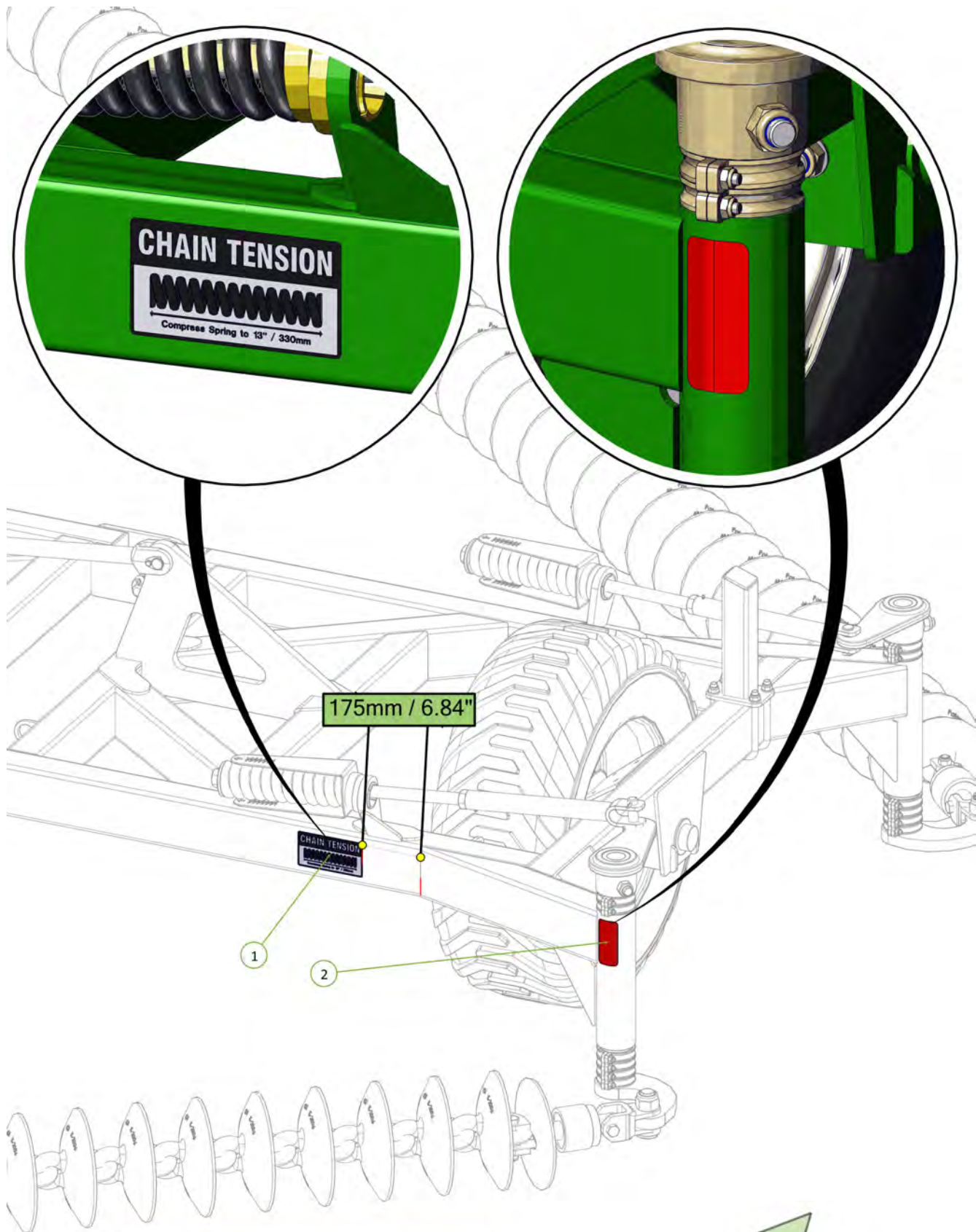

Item No.	Description	Qty	Number
1	Chain Tension 330mm Decal	1	0801-S15
2	Red Reflective Decal	1	0801-SRRF



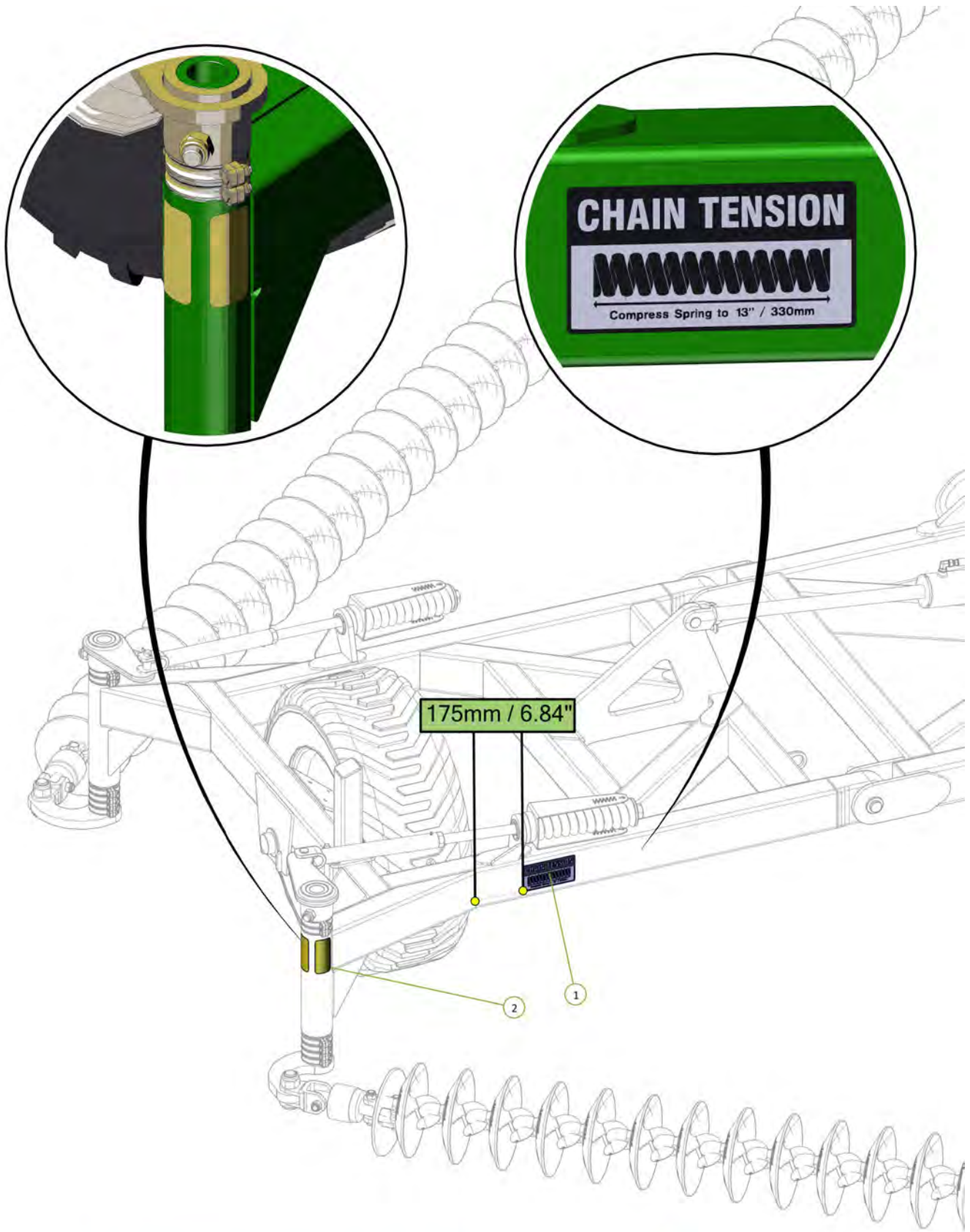

175mm / 6.84"

Item No.	Description	Qty	Number
1	Chain Tension 330mm Decal	1	0801-S15
2	Yellow Reflective Decal	2	0801-SYRF



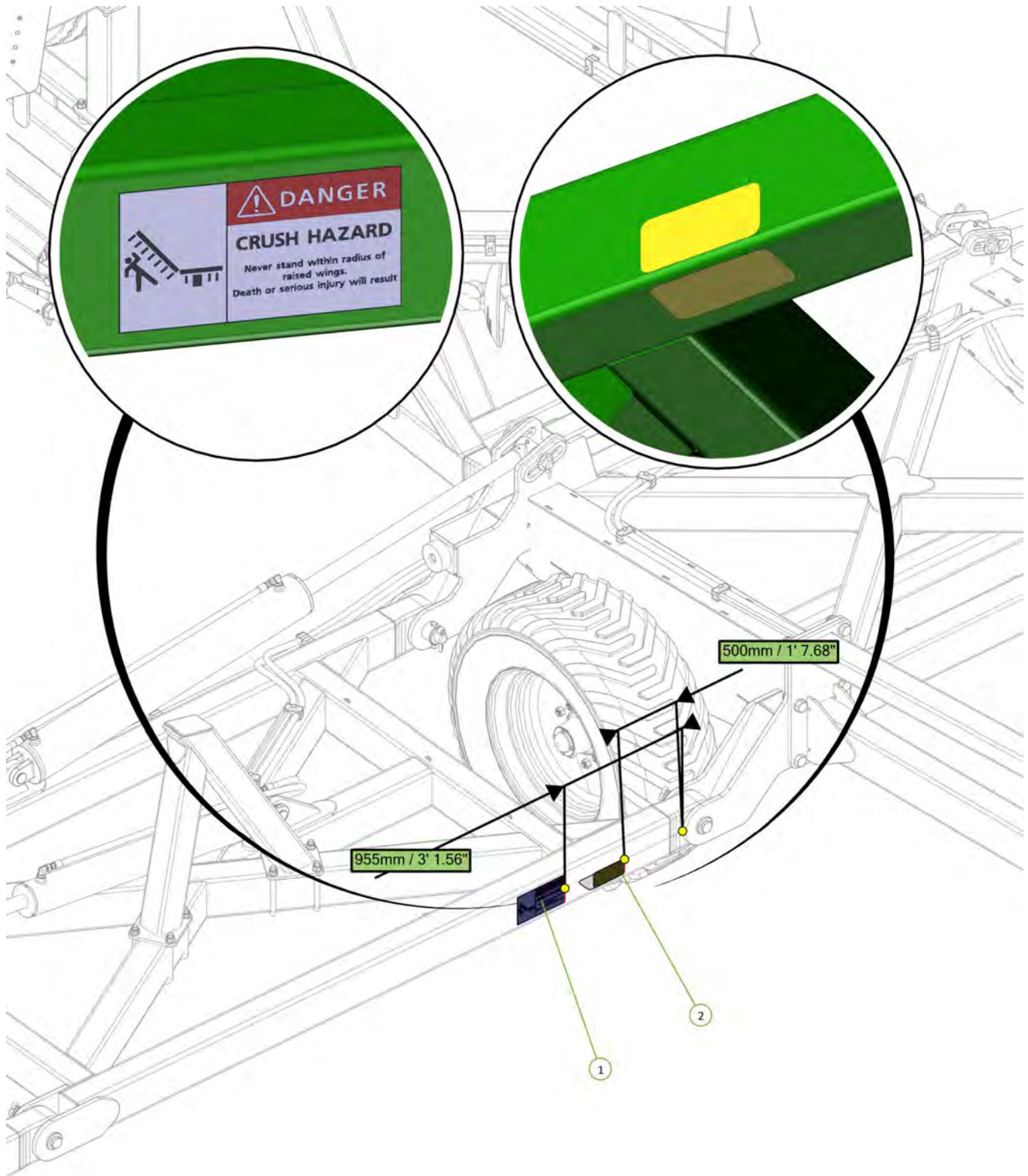

Item No.	Description	Qty	Number
1	Danger Crush Hazard Decal	1	0801-S3
2	Yellow Reflective Decal	2	0801-SYRF

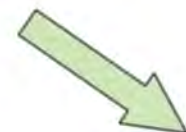

Item No.	Description	Qty	Number
1	Decal, 400/55/22.5 Tyre Inflation	4	0801-S8-400-55-22.5
2	Wheel Nut Decal	4	0801-S9

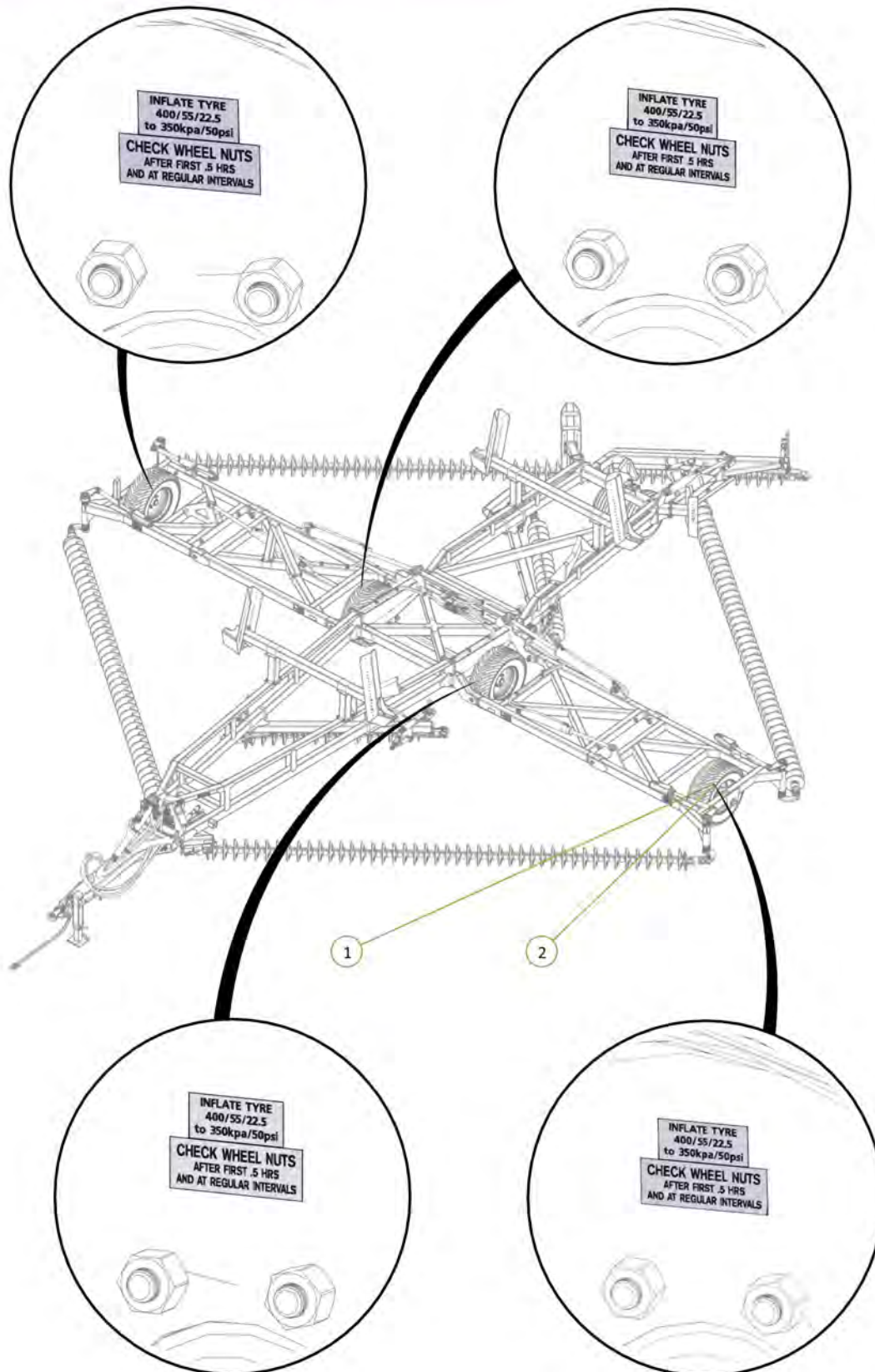

Item No.	Description	Qty	Number
1	Decal, 11L-15 Tyre Inflation	2	0801-S8-11L-15
2	Wheel Nut Decal	2	0801-S9

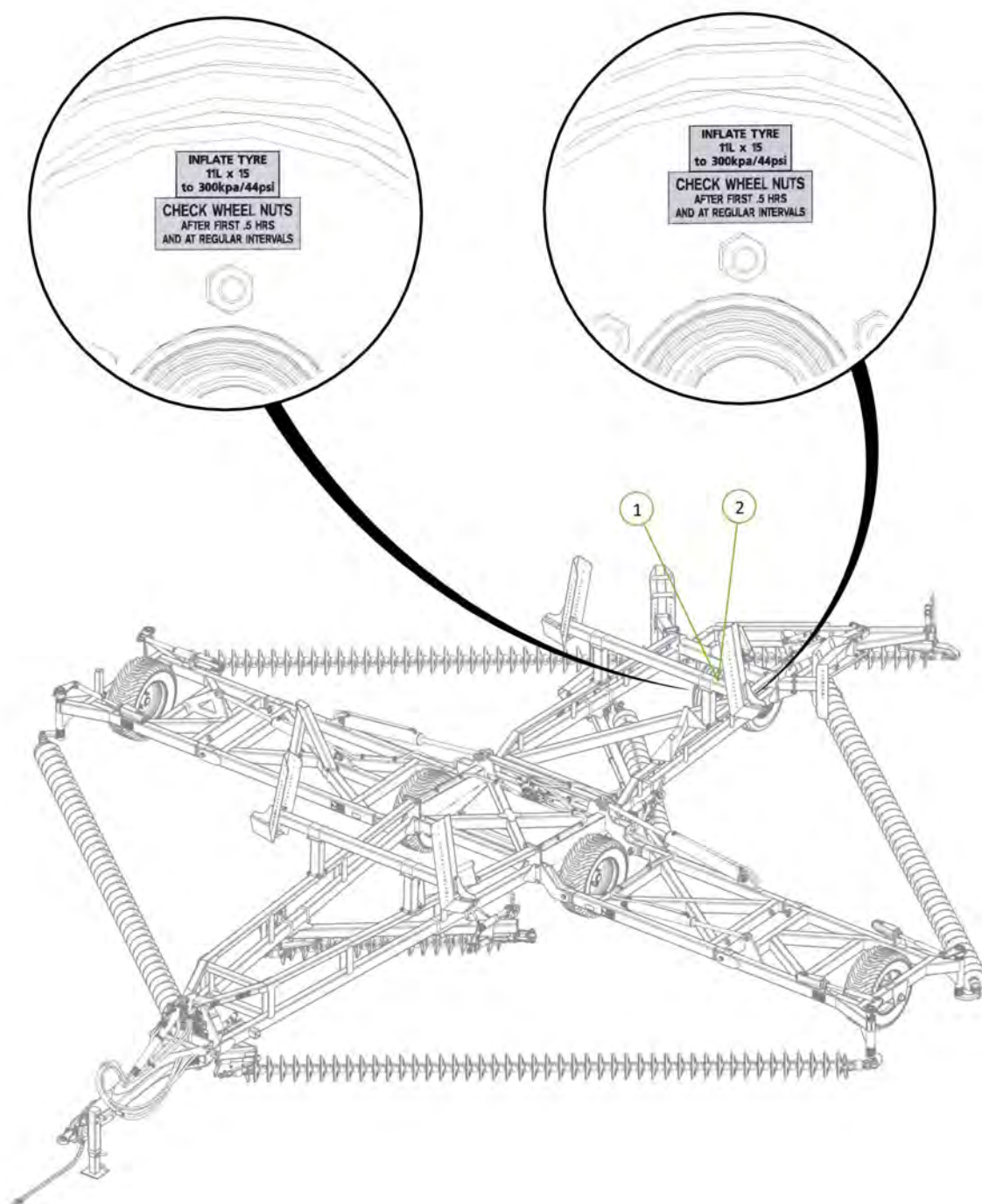

KELLY

Section 4 - Light Kit

Item No.	Description	Number	Qty
1	M6 x 20 Trilobe self tapping Screw	0211-M620MZPHTF	2
2	Electrical Plug Keeper	0416-11750B	1

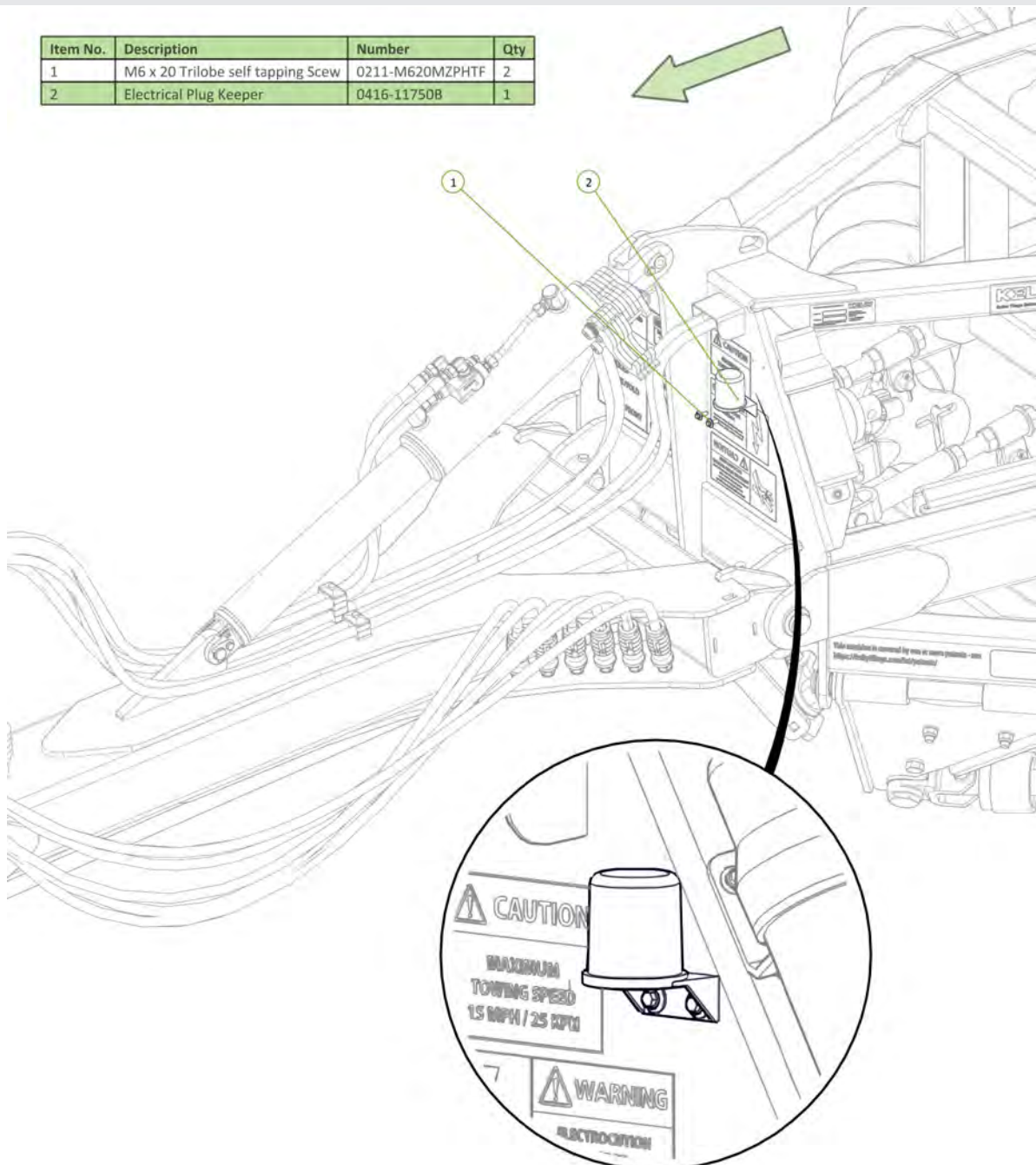

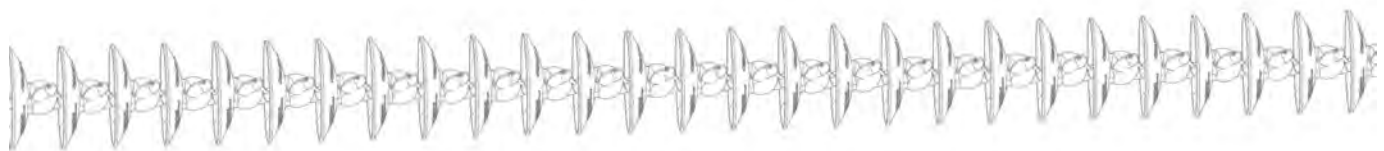
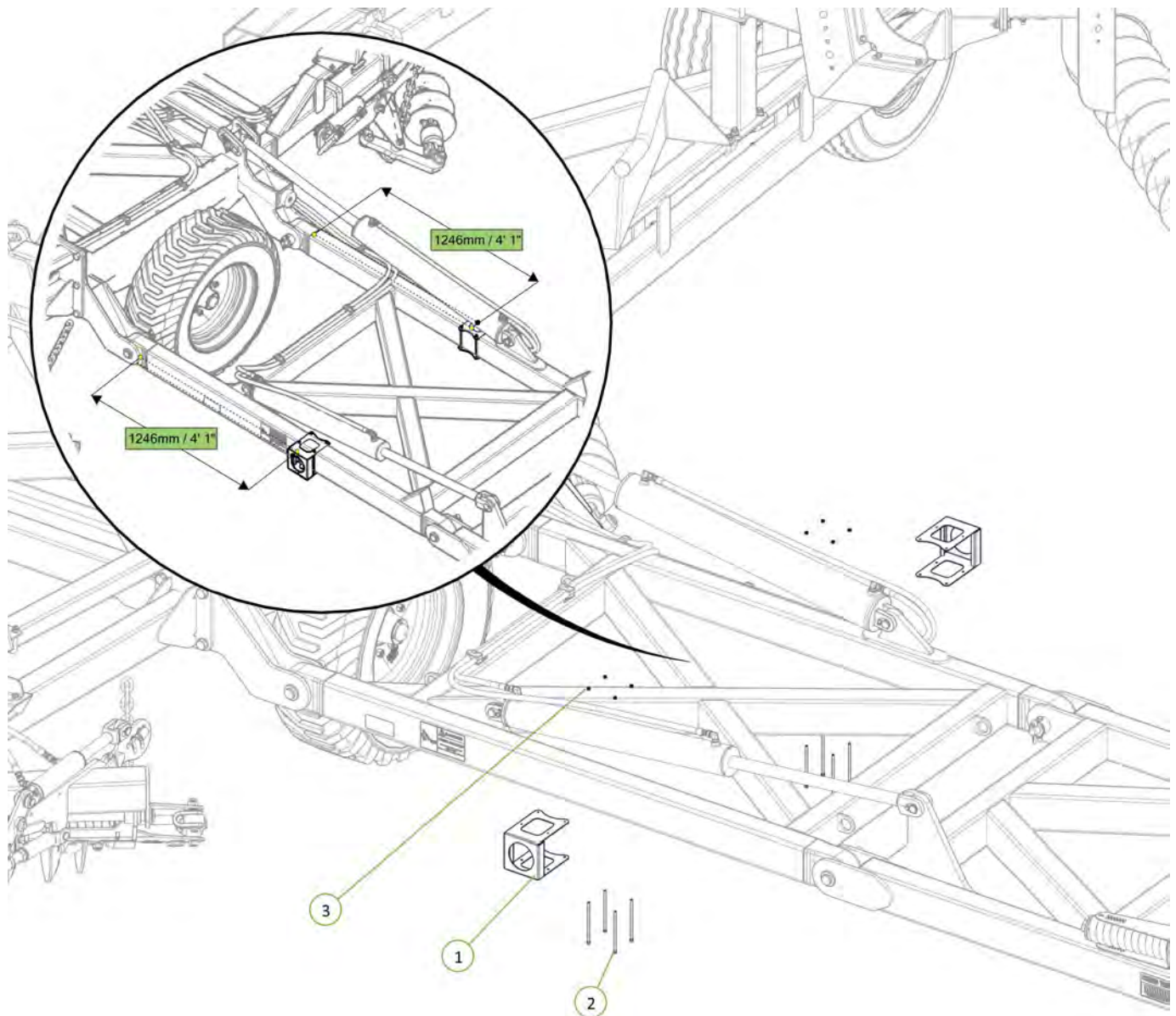

Item No.	Description	Number	Qty
1	Wing light bracket	0800-296	2
2	Socket Head Bolt M6 x 170 zp	0211-SH6170	8
3	Nyloc Nut M6	0221-NYL6	8



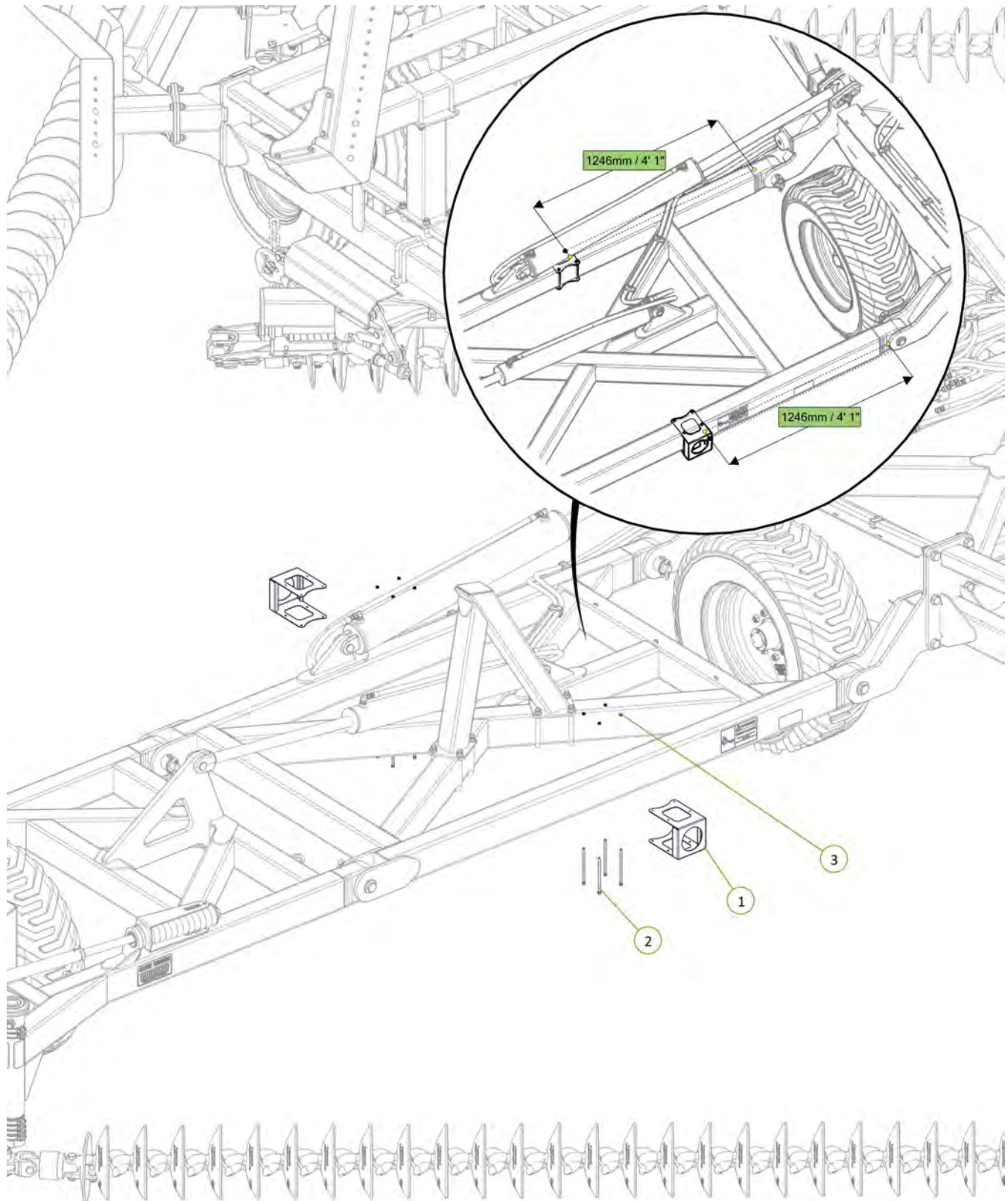

Item No.	Description	Number	Qty
1	Wing light bracket	0800-296	2
2	Socket Head Bolt M6 x 170 zp	0211-SH6170	8
3	Nyloc Nut M6	0221-NYL6	8



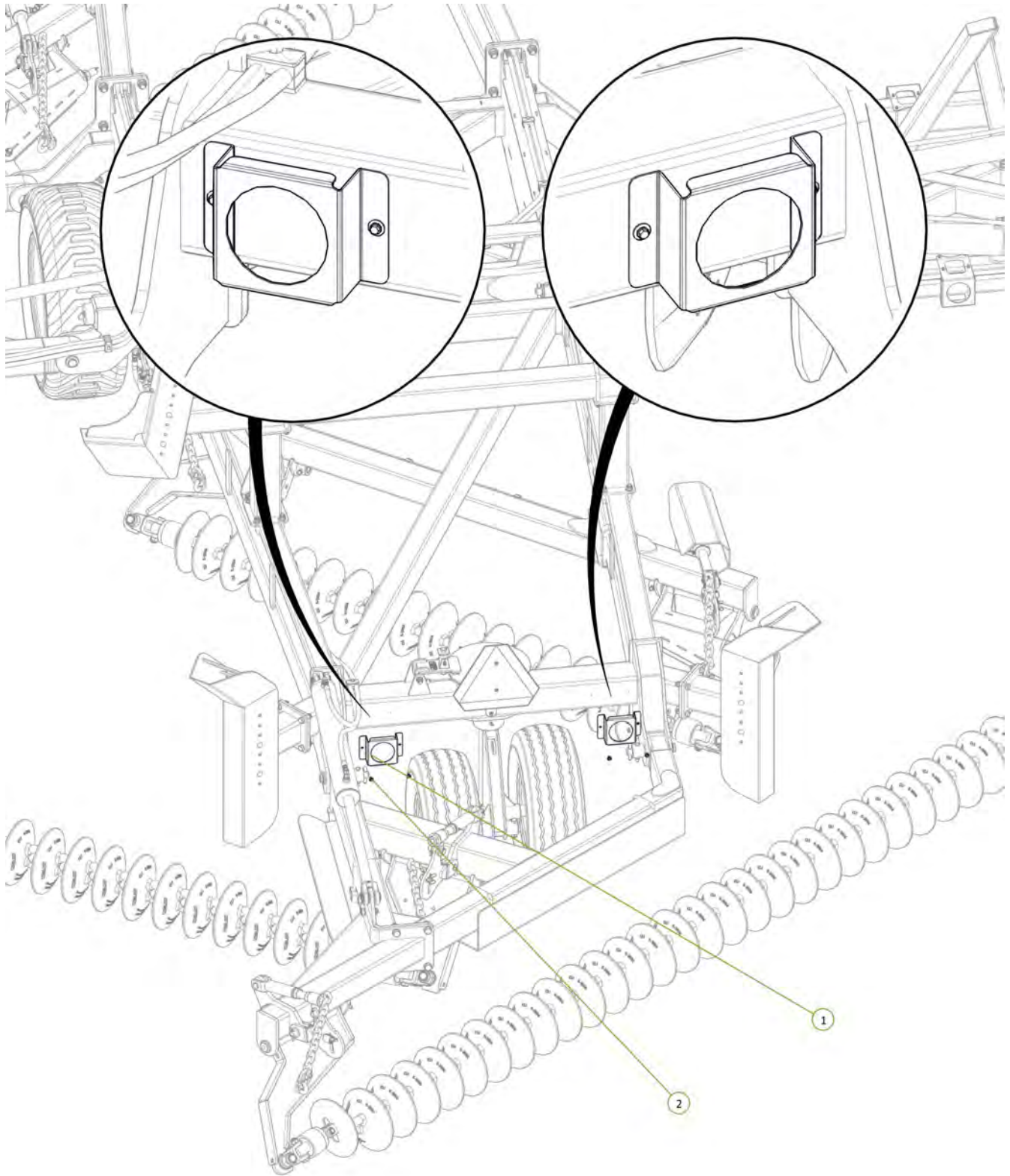

Item No.	Description	Number	Qty
1	US Tail Light Bracket	0800-194.1	2
2	M6 x 20 Trilobe self tapping Screw	0211-M620MZPHTF	4



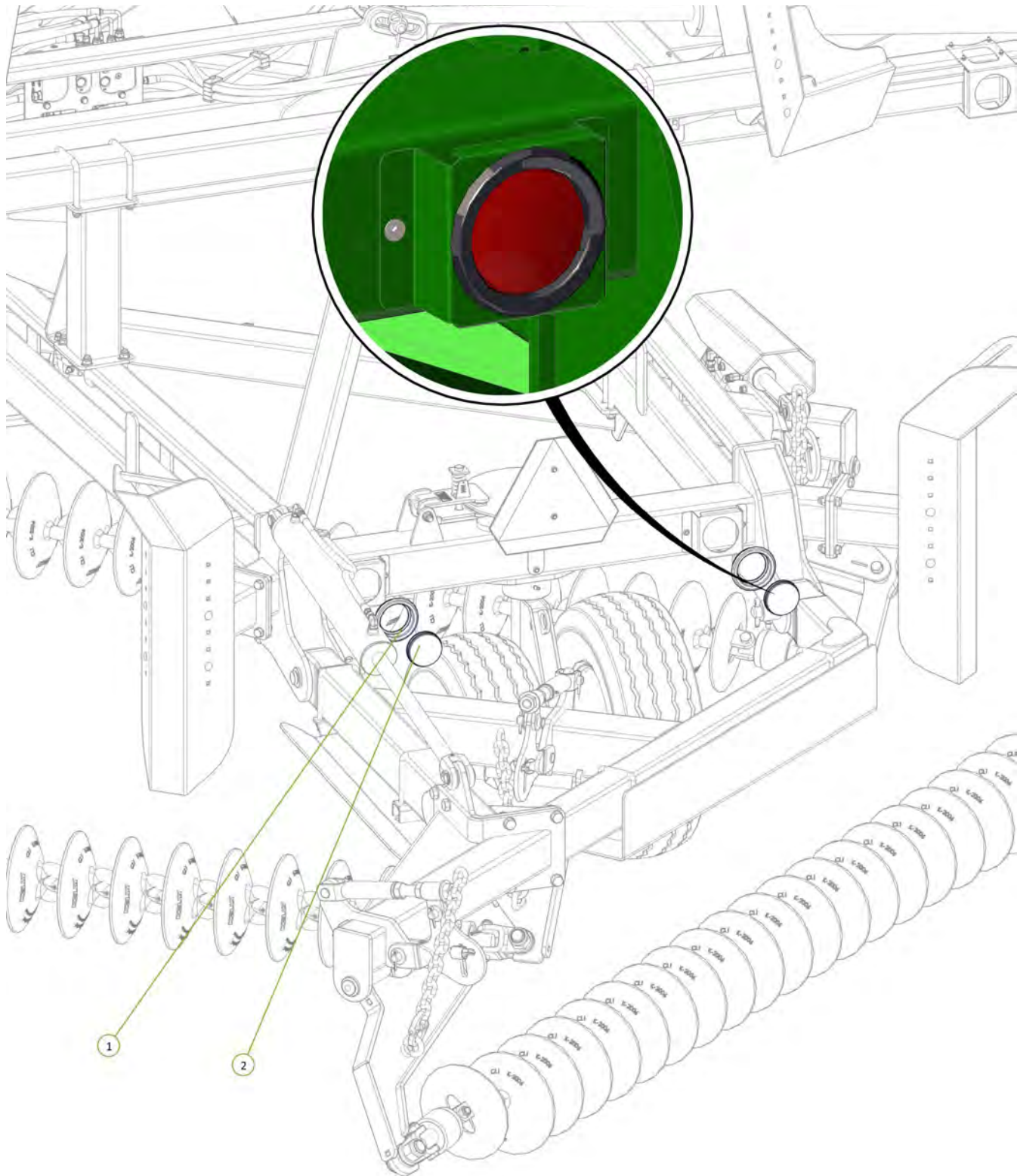

Item No.	Description	Number	Qty
1	110RM Rubber Grommet	0412-53101RG	2
2	LED Stop Tail Lamp	0412-LED110RM	2



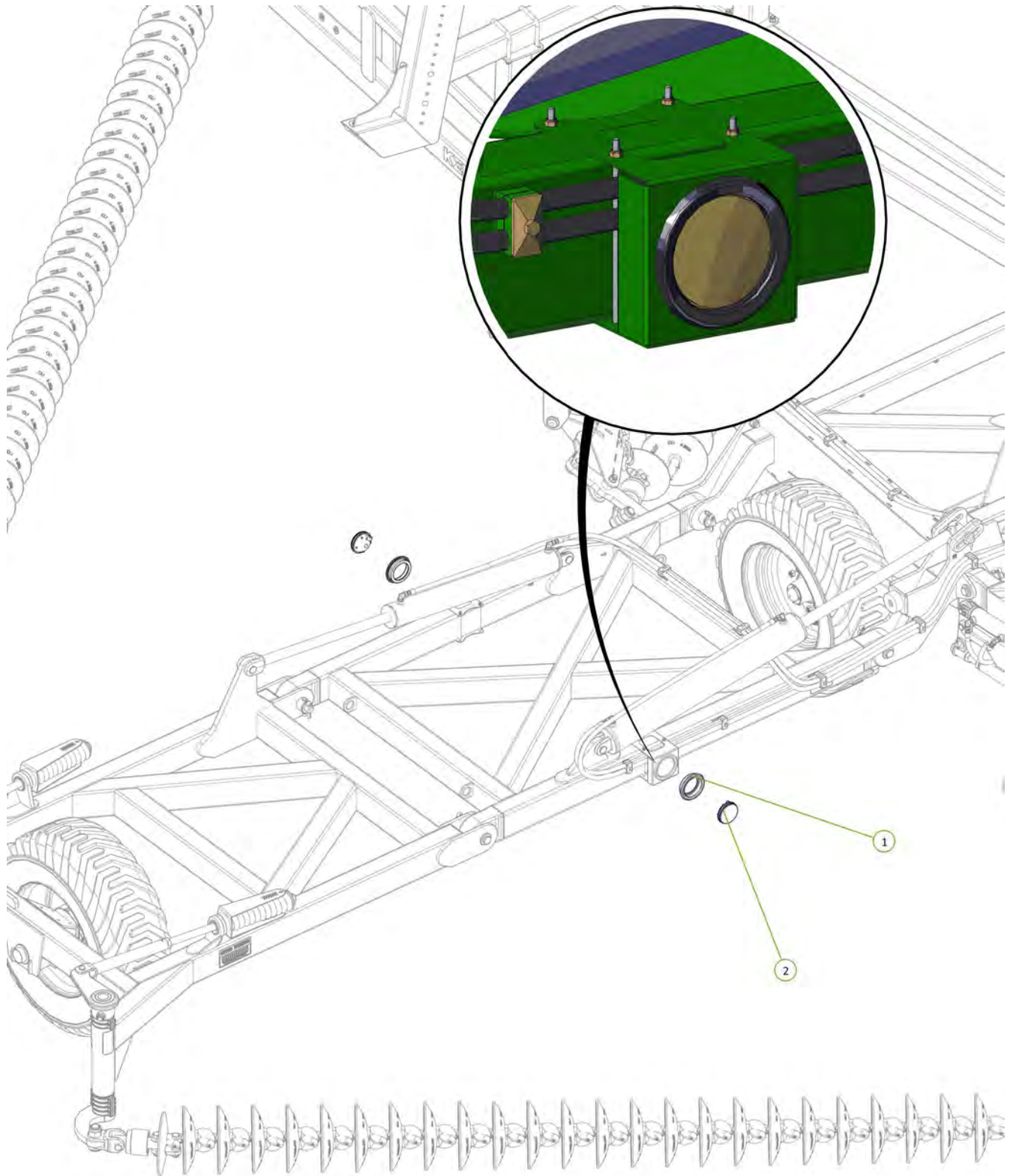

Item No.	Description	Number	Qty
1	110RM Rubber Grommet	0412-53101RG	2
2	LED Rear Indicator Lamp	0412-LED110AM	2

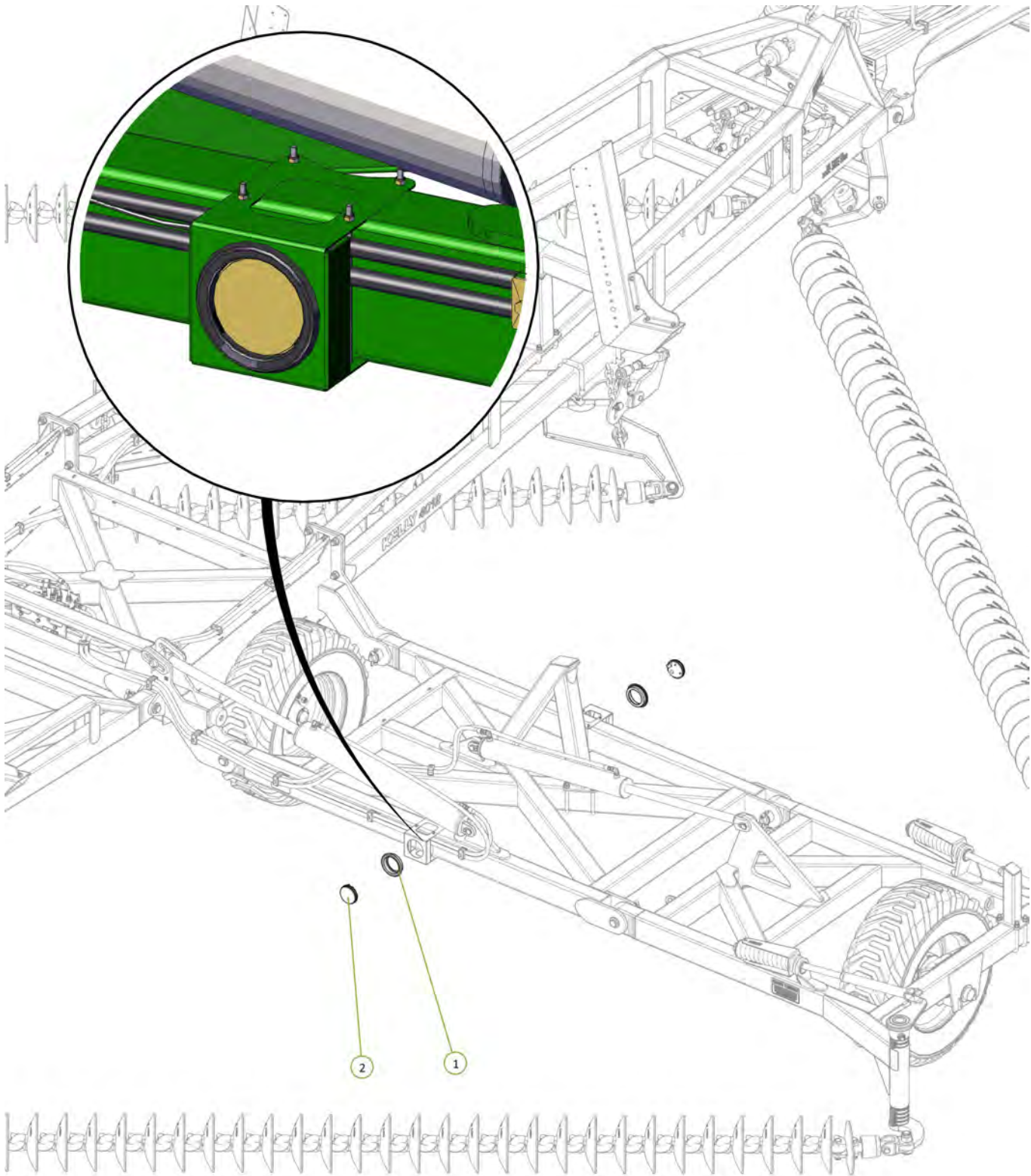

Item No.	Description	Number	Qty
1	110RM Rubber Grommet	0412-53101RG	2
2	LED Rear Indicator Lamp	0412-LED110AM	2

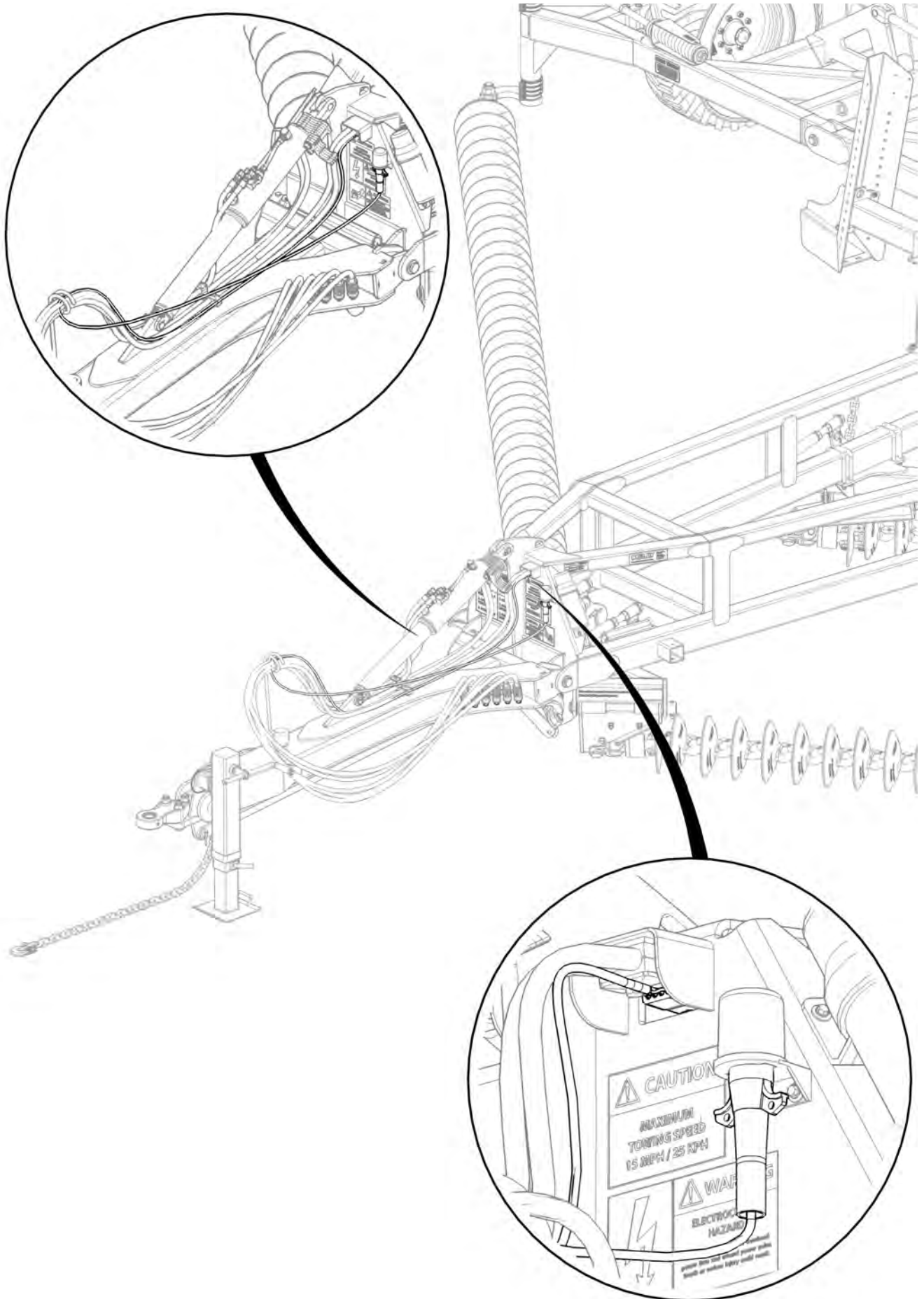

Attach loom to provided tabs with zip ties

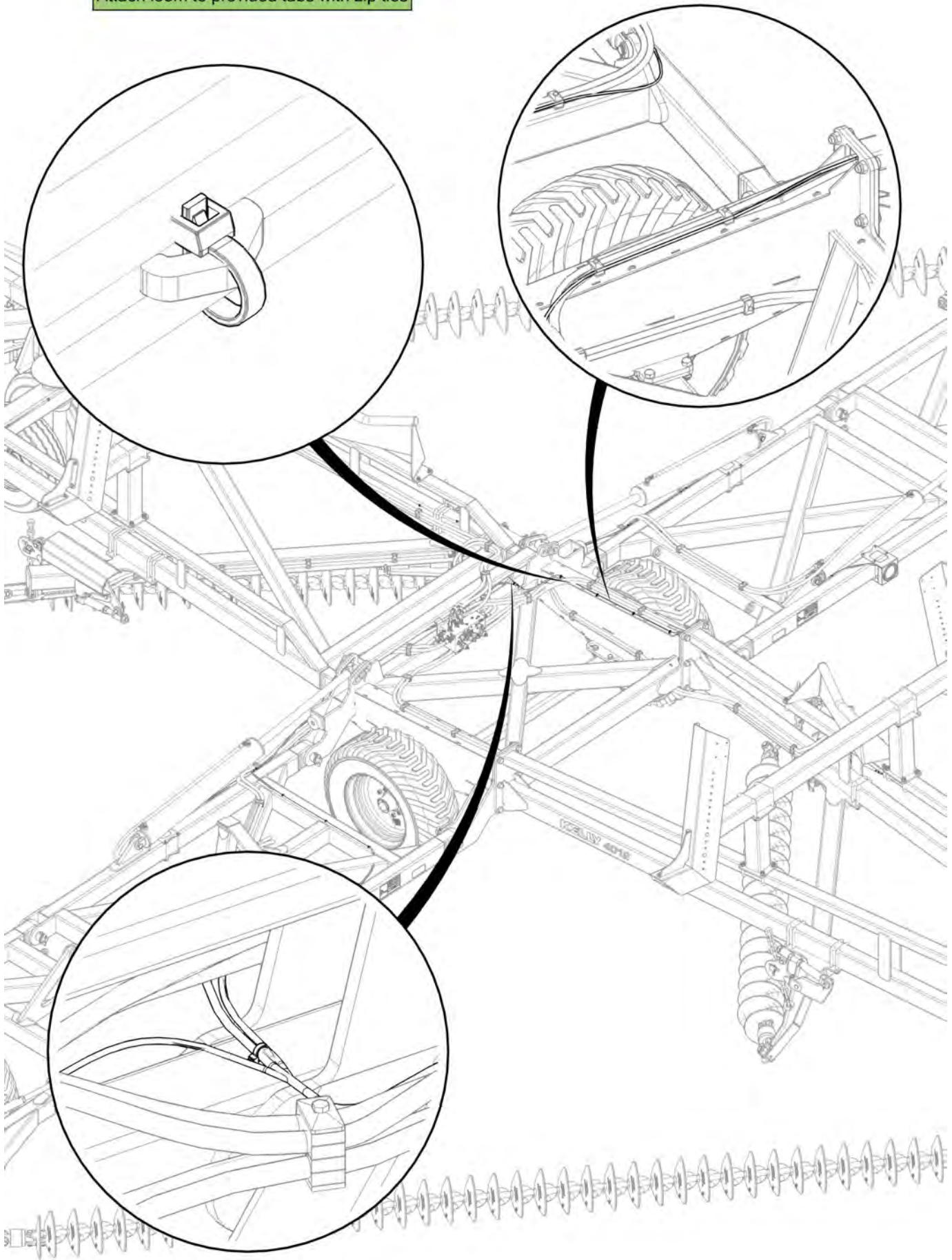

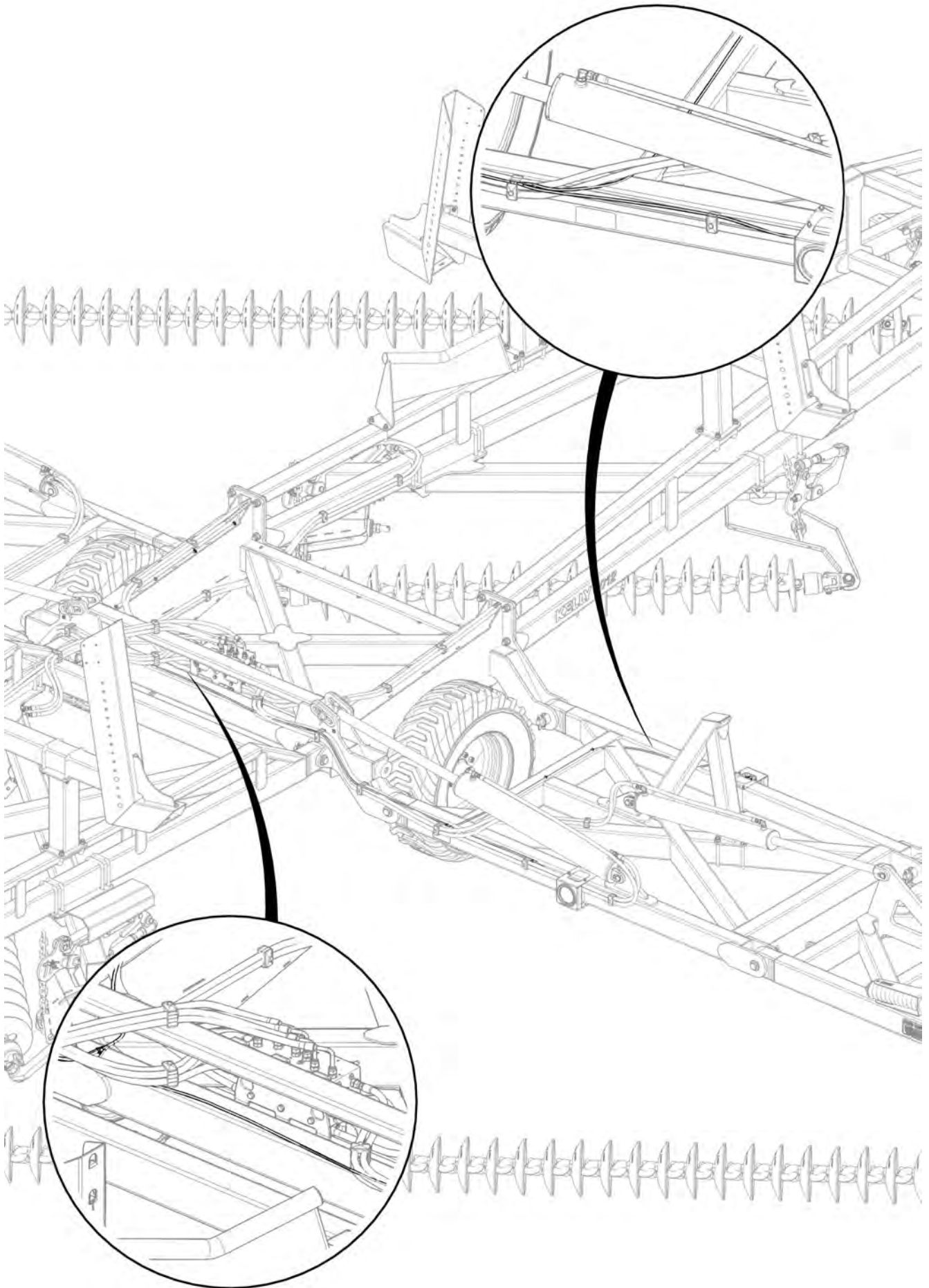

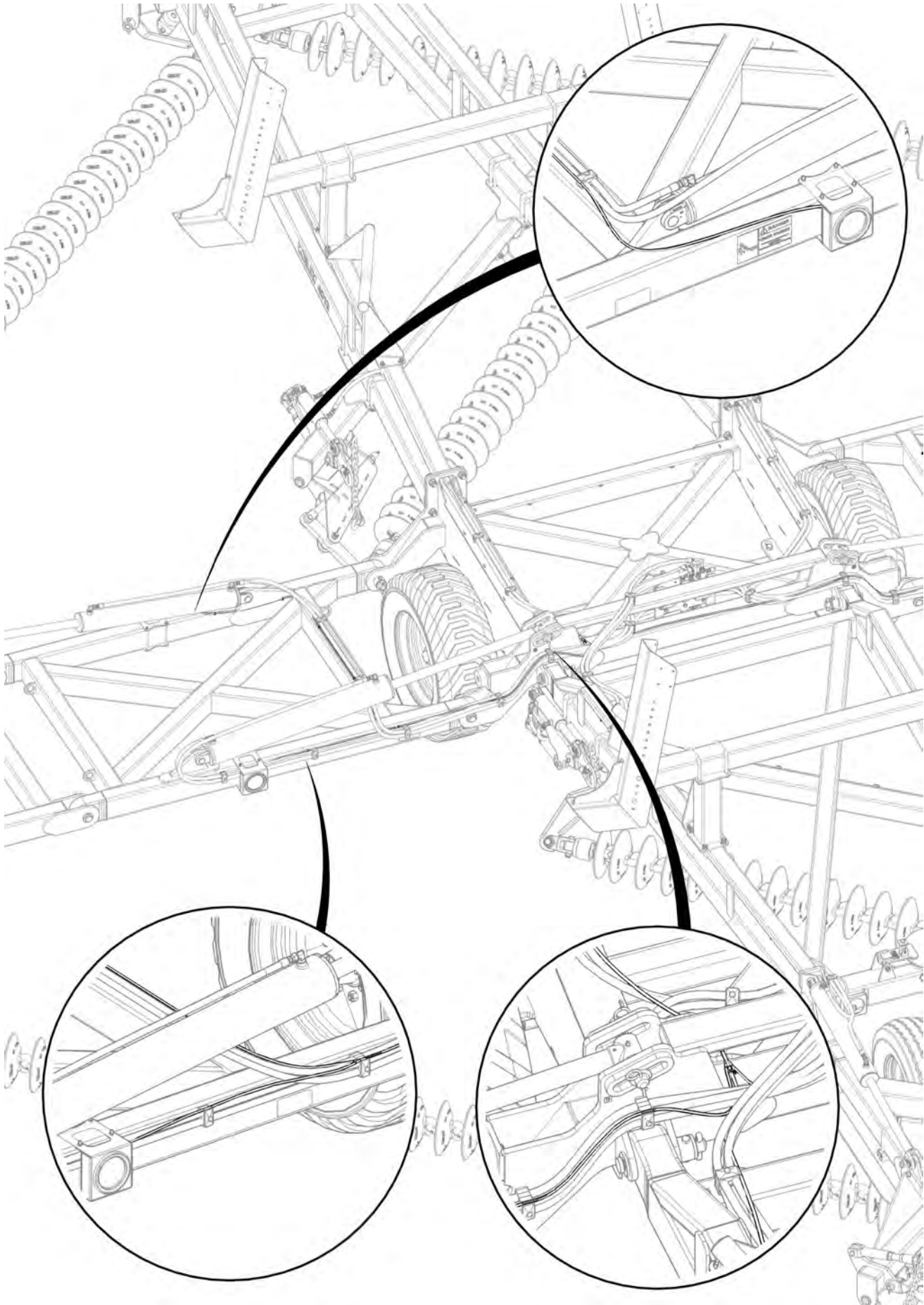

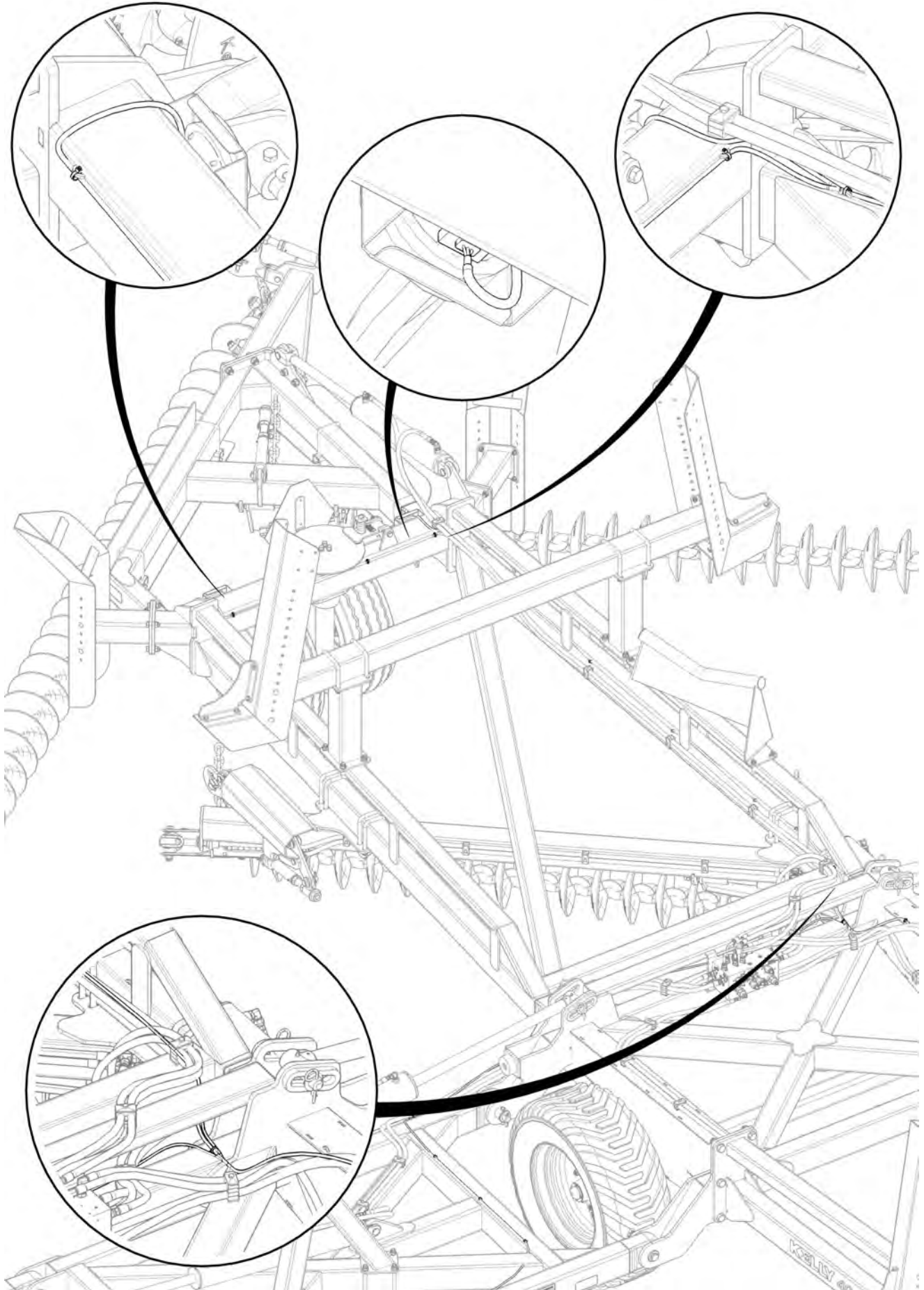

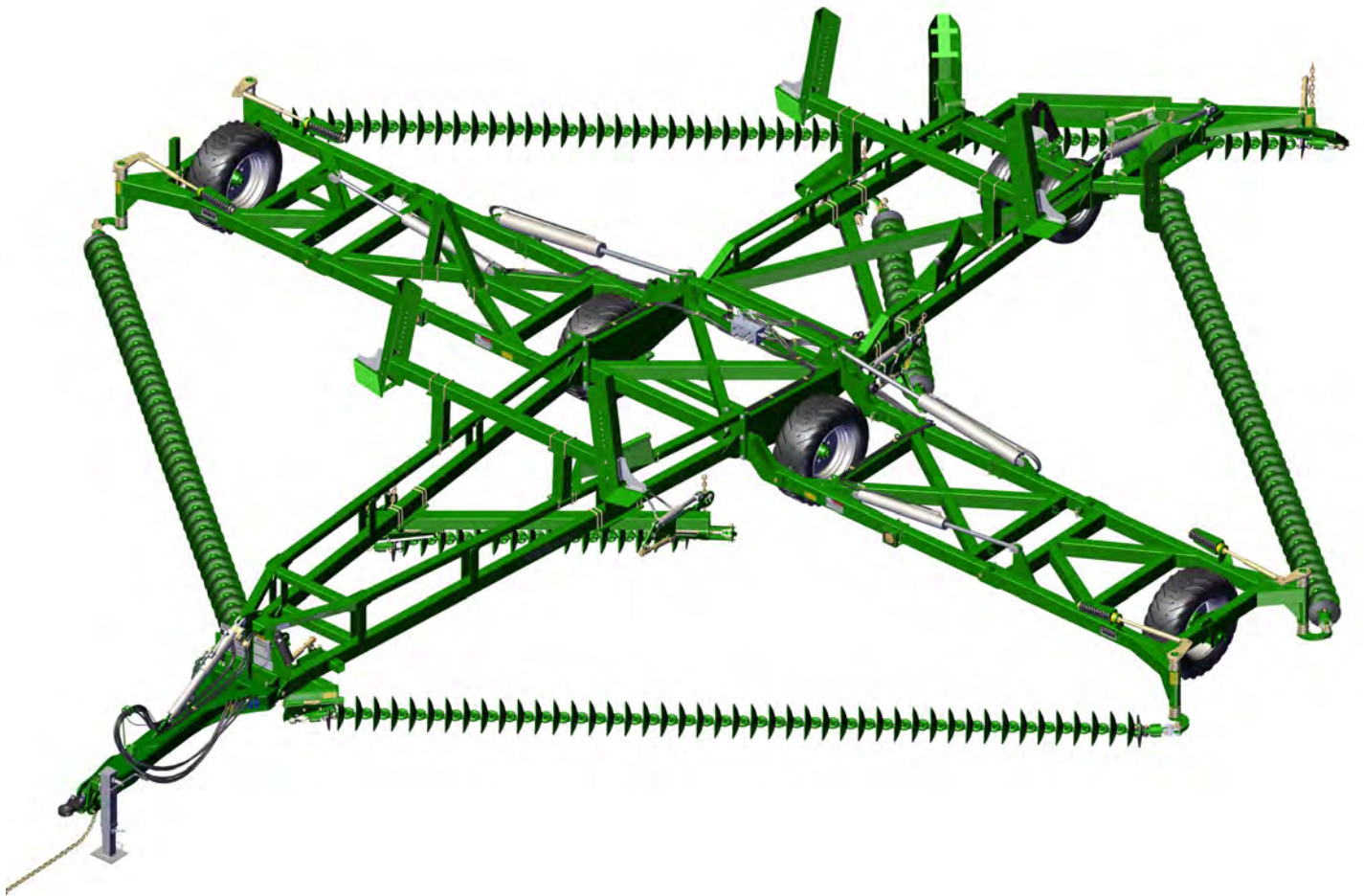



Section 5 - Chain Assembly

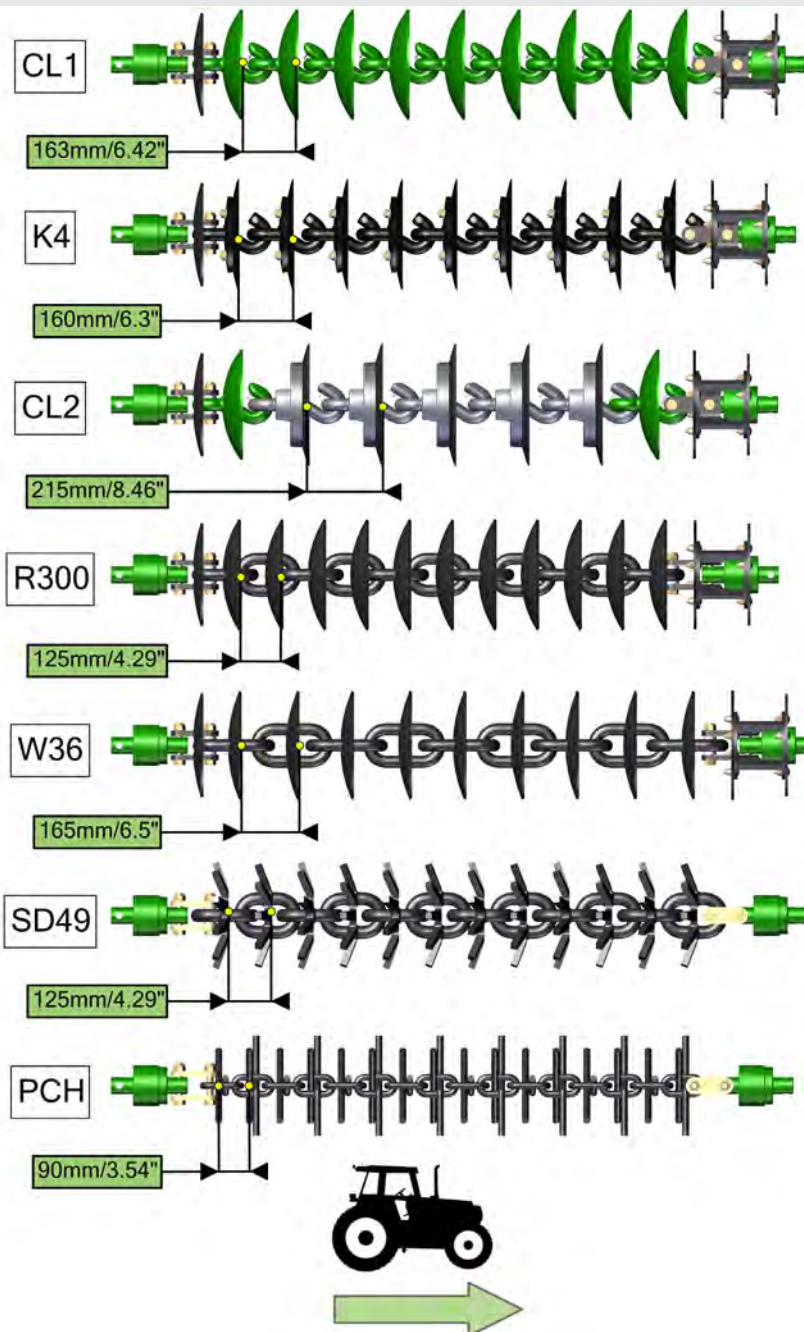

Item No.	Description	Number
1	Nyloc Nut M20	0221-NYL20
2	M20 x 110 Class 10.9 ZP Short Thread Bolt	0211-20110ST
3	20mm Bolt Swivel Unit	0802-PCHB55
4	Tie Plate Disc 20mm	0802-DCTP-20
5	Disc Chain Spacer	0801-253755
6	Roll Pin Zinc Plated 3/8" x 2"	0262-3-8X2
7	CL1-B Chain Disc Link	0803-CL1

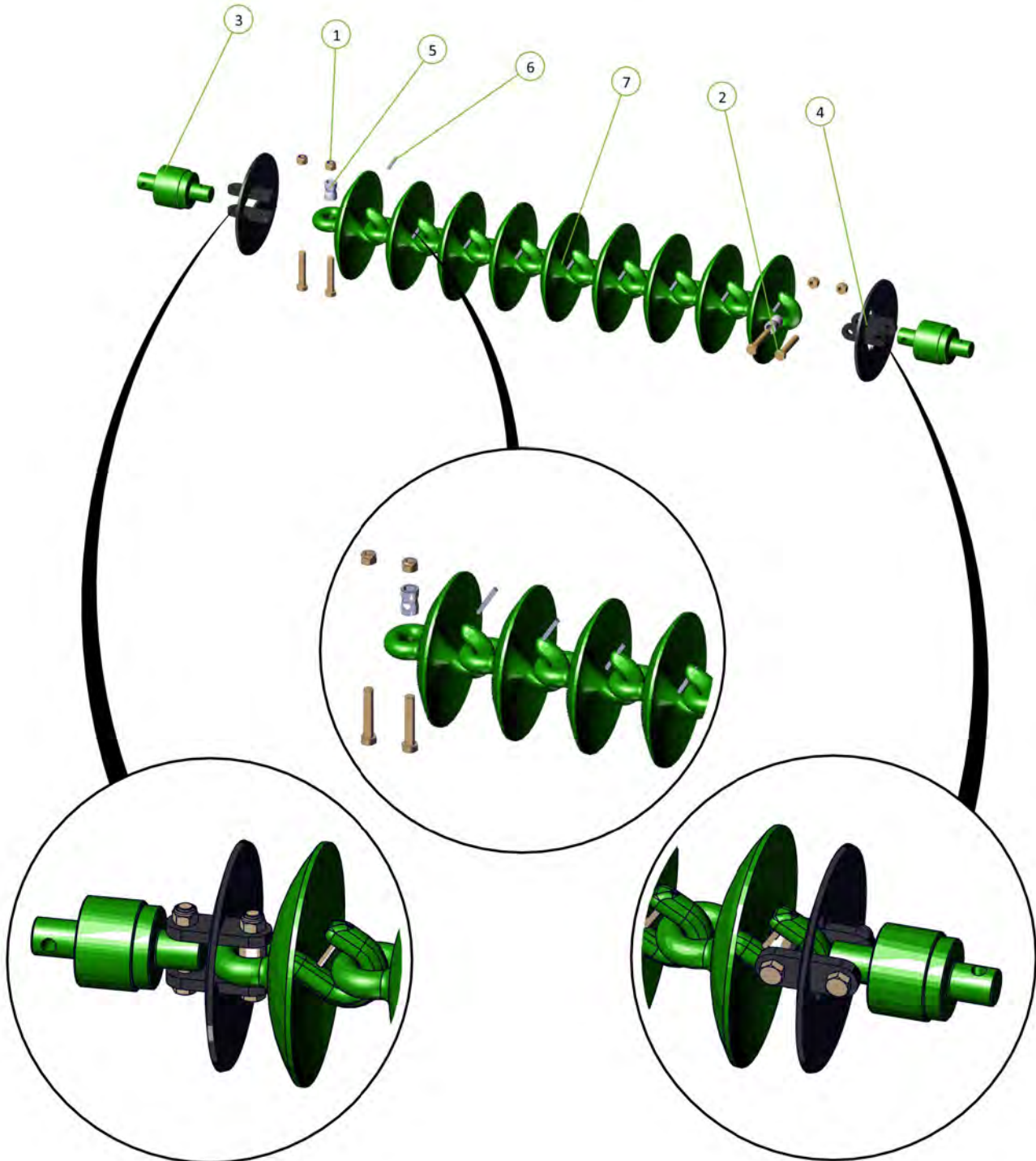

Fitting Cast Link Pins

Please install cast link retaining Pins (Roll Pin Zinc Plated 3/8" x 2", part number 0262-3-8X2) on all cast disc links.

Failure to do this could lead to the discs becoming dislodged during transport causing severe damage or injury.

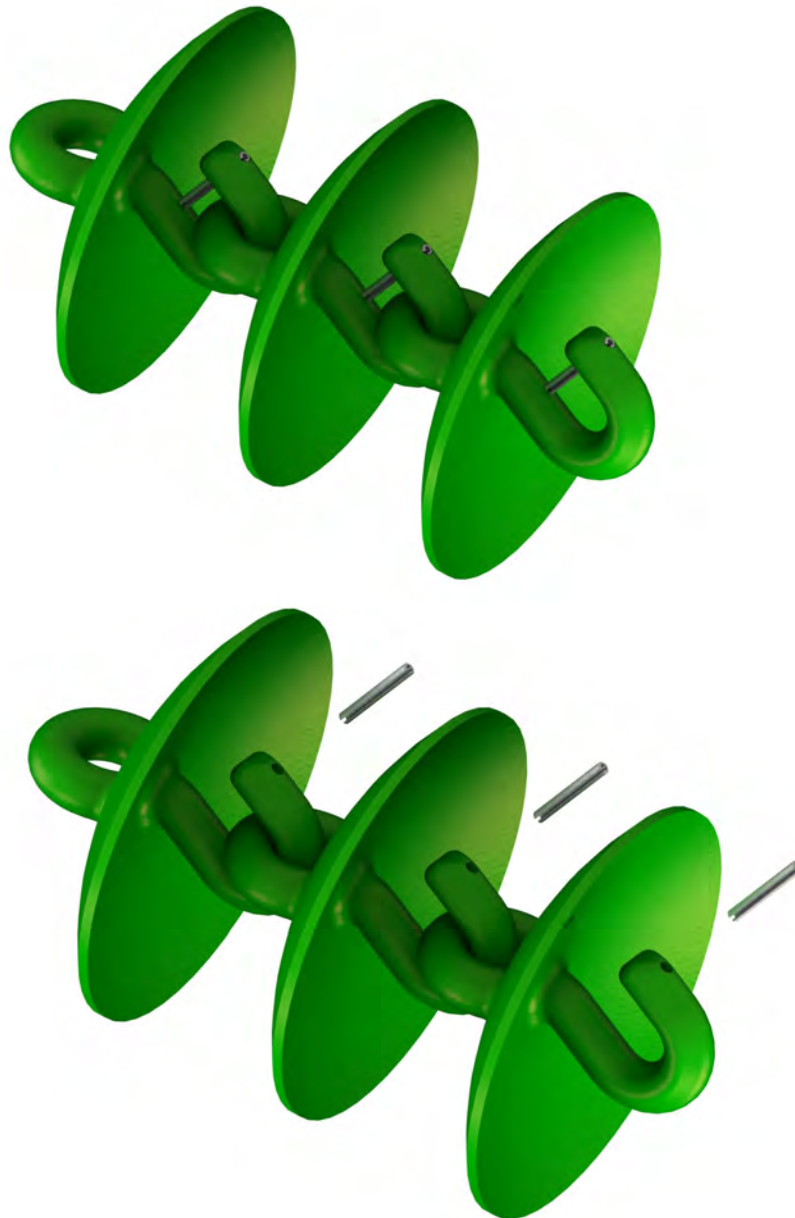

Item No.	Description	Number
1	Nyloc Nut M20	0221-NYL20
2	M20 x 110 Class 10.9 ZP Short Thread Bolt	0211-20110ST
3	20mm Bolt Swivel Unit	0802-PCH-B55
4	Tie Plate Disc 20mm	0802-DCTP-20
5	Disc Chain Spacer	0801-253755
6	K4 Disc Assembly	0803-K4
7	M12 x 55 Class 8.8 ZP Bolt	0211-1255
8	Nyloc Nut M12	0221-NYL12

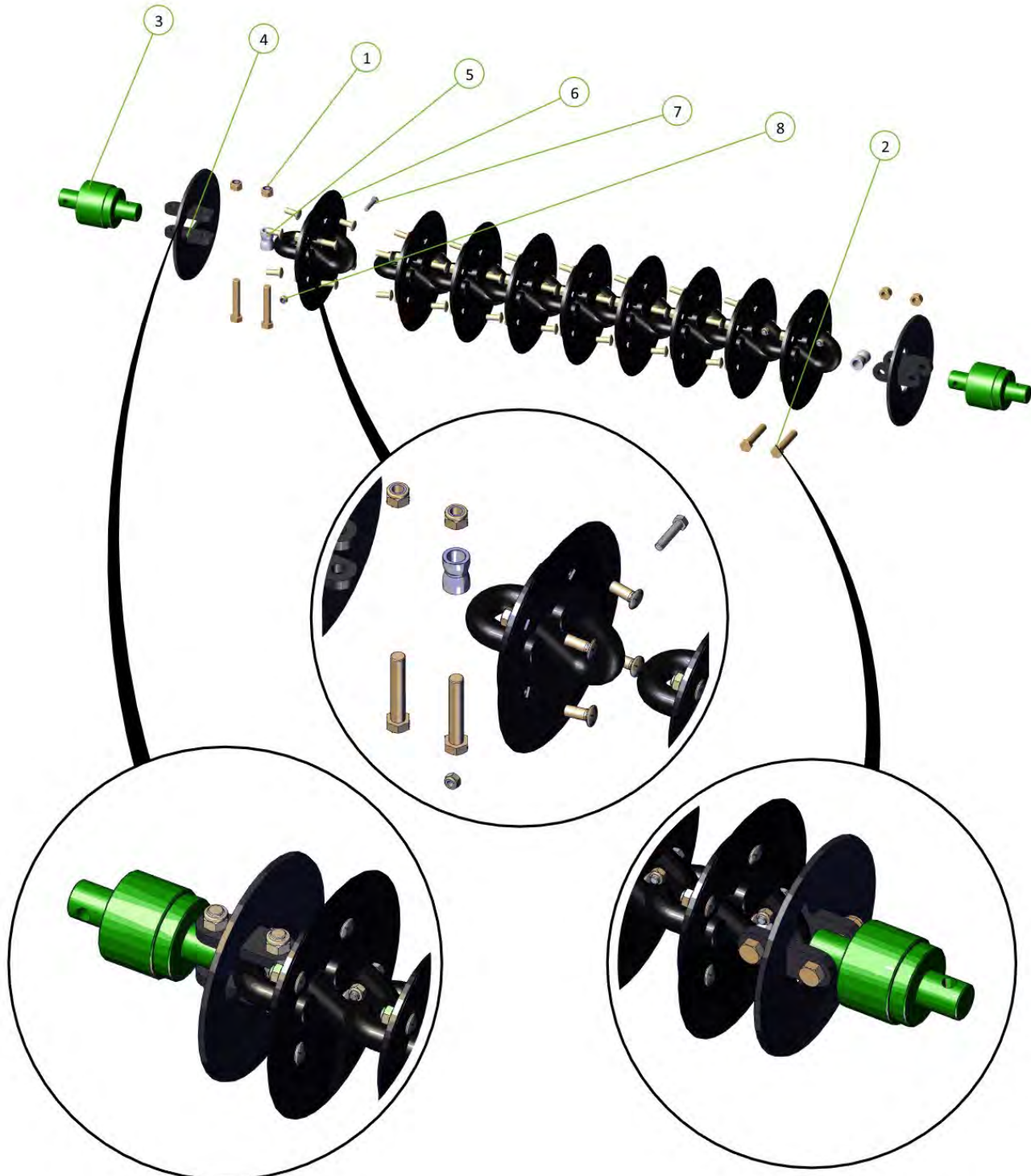

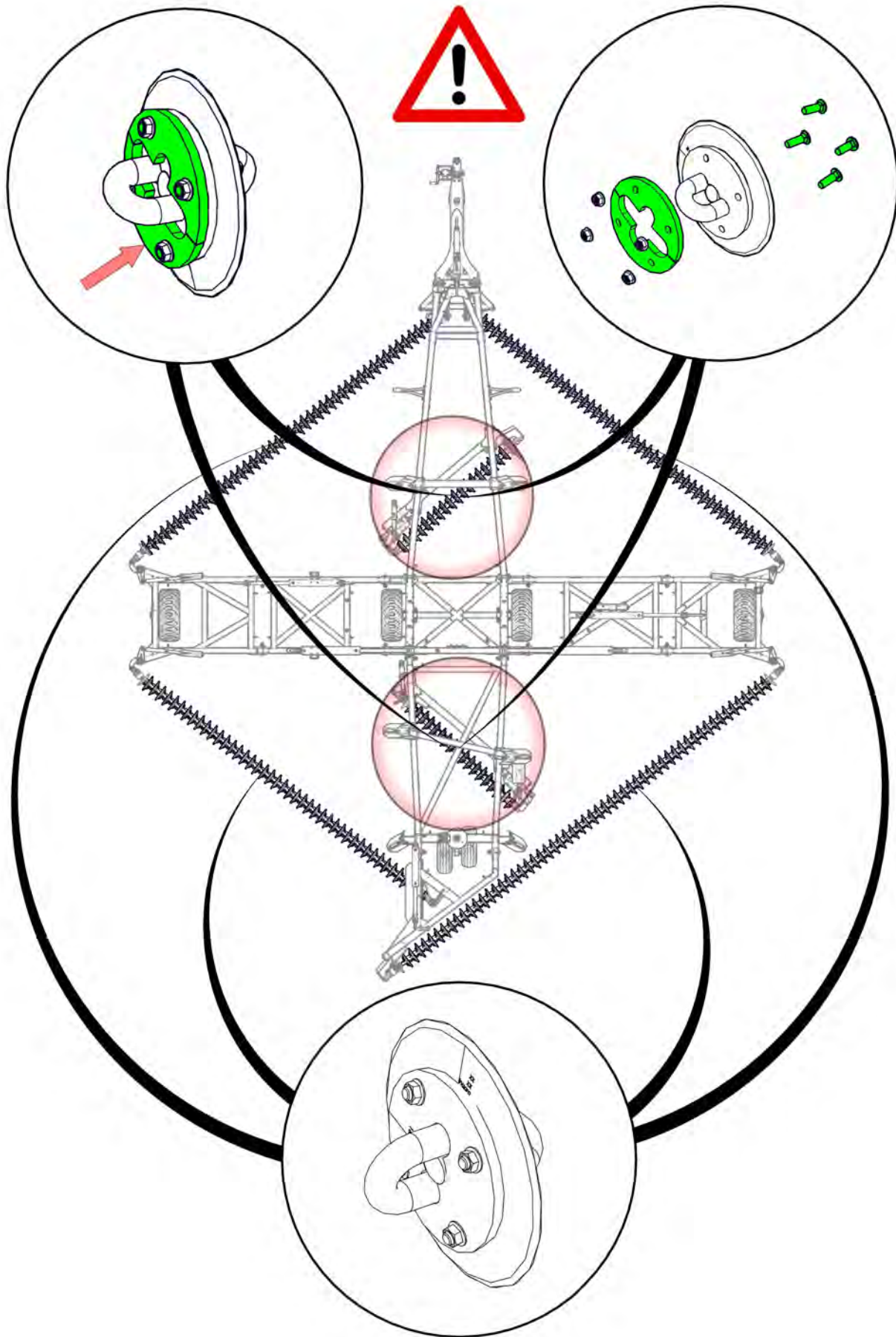

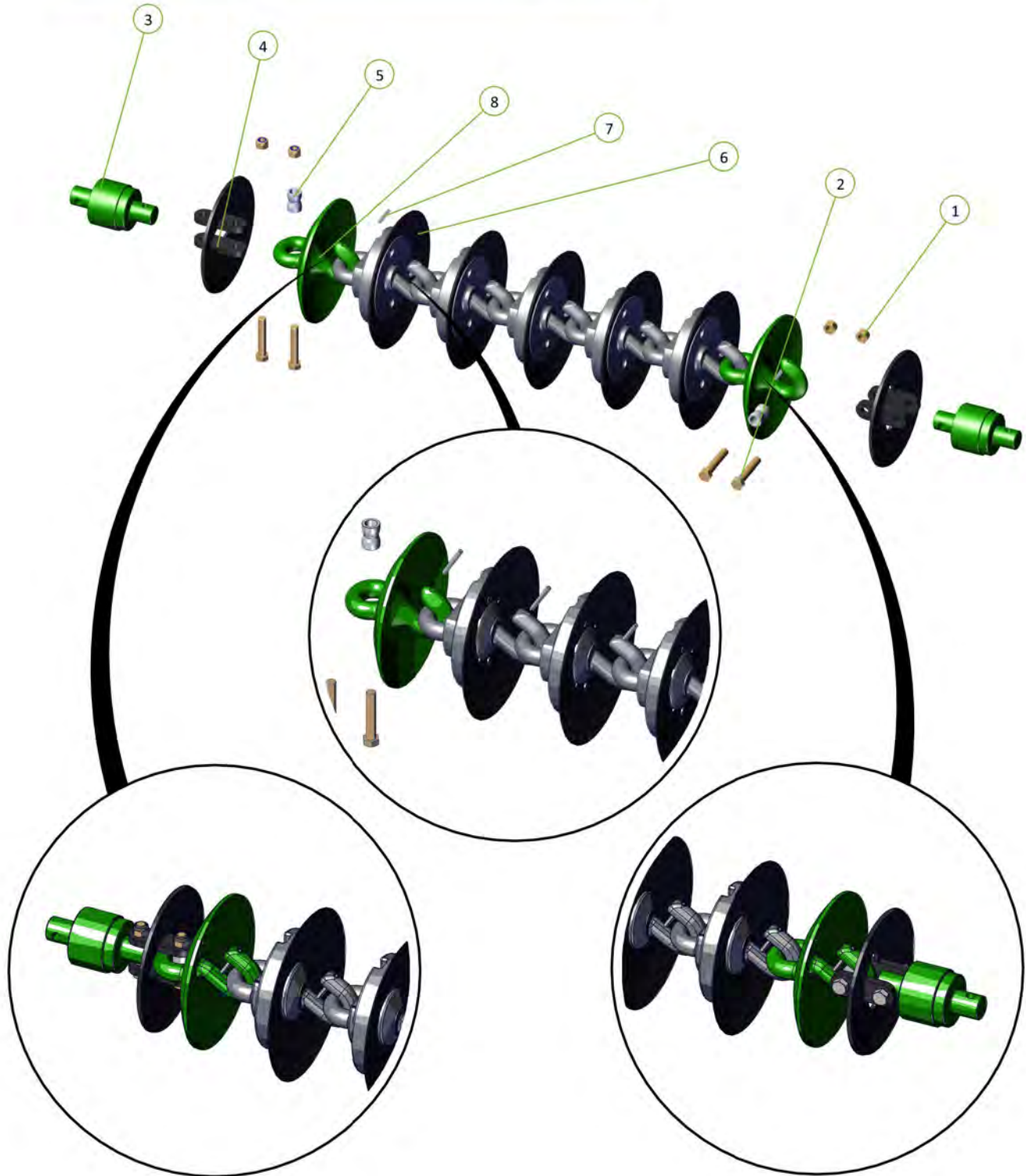

Item No.	Description	Number
1	Nyloc Nut M20	0221-NYL20
2	M20 x 110 Class 10.9 ZP Short Thread Bolt	0211-20110ST
3	20mm Bolt Swivel Unit	0802-PCHB55
4	Tie Plate Disc 20mm	0802-DCTP-20
5	Disc Chain Spacer	0801-253755
6	CL2-Link Assembly	0803-CL2
7	Roll Pin Zinc Plated 3/8" x 2"	0262-3-8X2
8	CL1 Disc Chain Link	0803-CL1

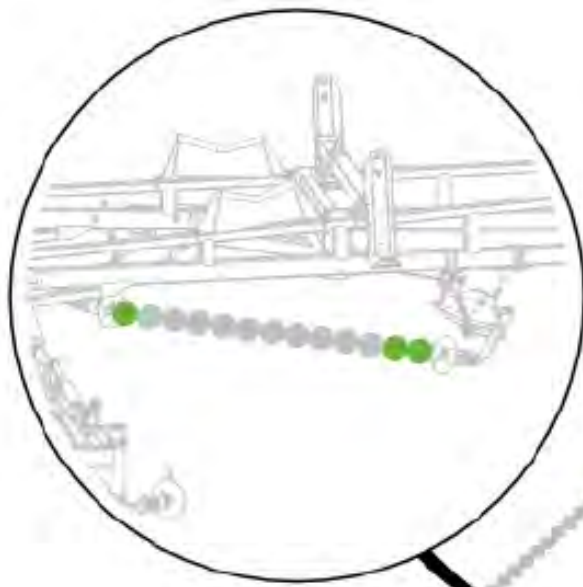



Set	CL2 	CL1 
Front Left	32	2
Front Right	32	2
Front Modules	10	3
Front Set	74	7
Rear Right	31	15
Rear Left	29	2
Rear Modules	10	2
Rear Set	70	19
Total	144	26

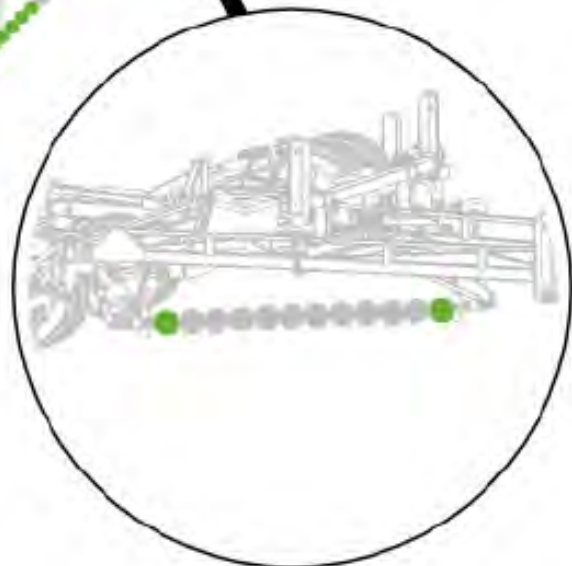
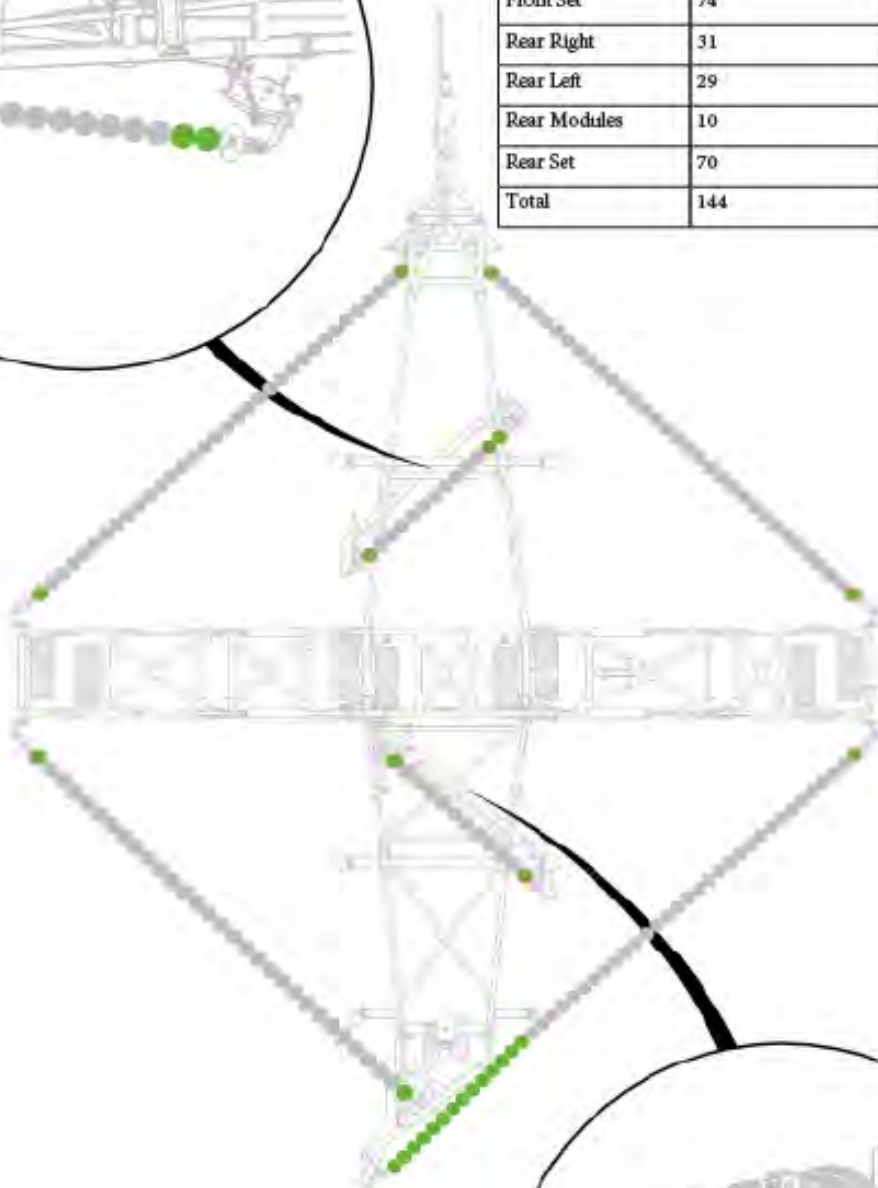

Item No.	Description	Number
1	Nyloc Nut M20	0221-NYL20
2	M20 x 110 Class 10.9 ZP Short Thread Bolt	0211-20110ST
3	20mm Bolt Swivel Unit	0802-PCHB55
4	Tie Plate Disc 20mm	0802-DCTP-20
5	Disc Chain Spacer	0801-253755
6	R300 Chain Link	0803-R300

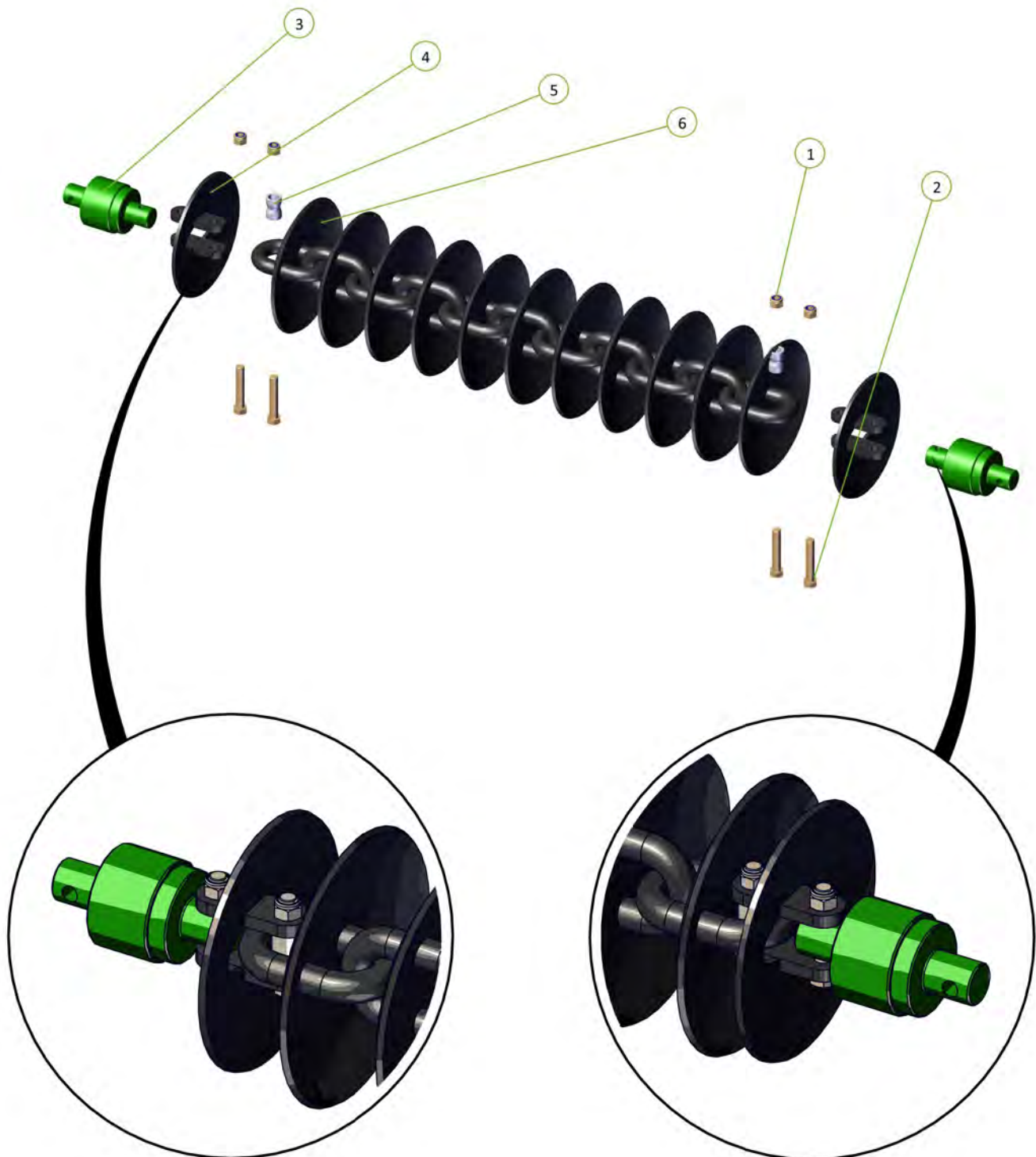

Item No.	Description	Number
1	Nyloc Nut M20	0221-NYL20
2	M20 x 110 Class 10.9 ZP Short Thread Bolt	0211-20110ST
3	20mm Bolt Swivel Unit	0802-PCHB55
4	Tie Plate Disc 20mm	0802-DCTP-20
5	Disc Chain Spacer	0801-253755
6	W36/25 Chain Link	0803-W36

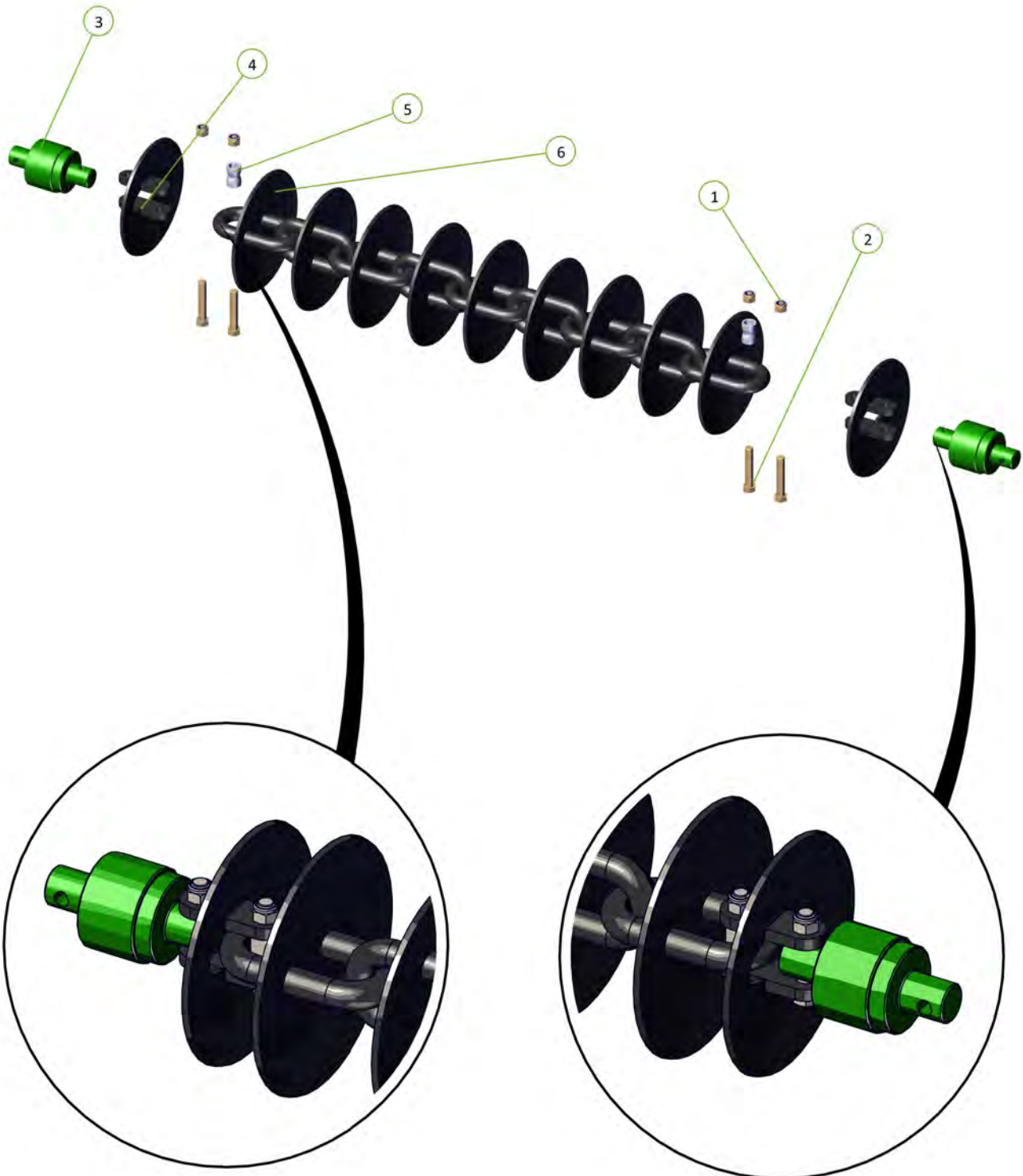
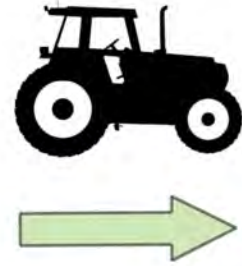

Item No.	Description	Number
1	Nyloc Nut M20	0221-NYL20
2	M20 x 110 Class 10.9 ZP Short Thread Bolt	0211-20110ST
3	20mm Bolt Swivel Unit	0802-PCHB55
4	Tie Plate For 20mm Bolt	0800-83.2
5	Disc Chain Spacer	0801-253755
6	10 Spike Disc Chain 49/27/5	0803-SD49

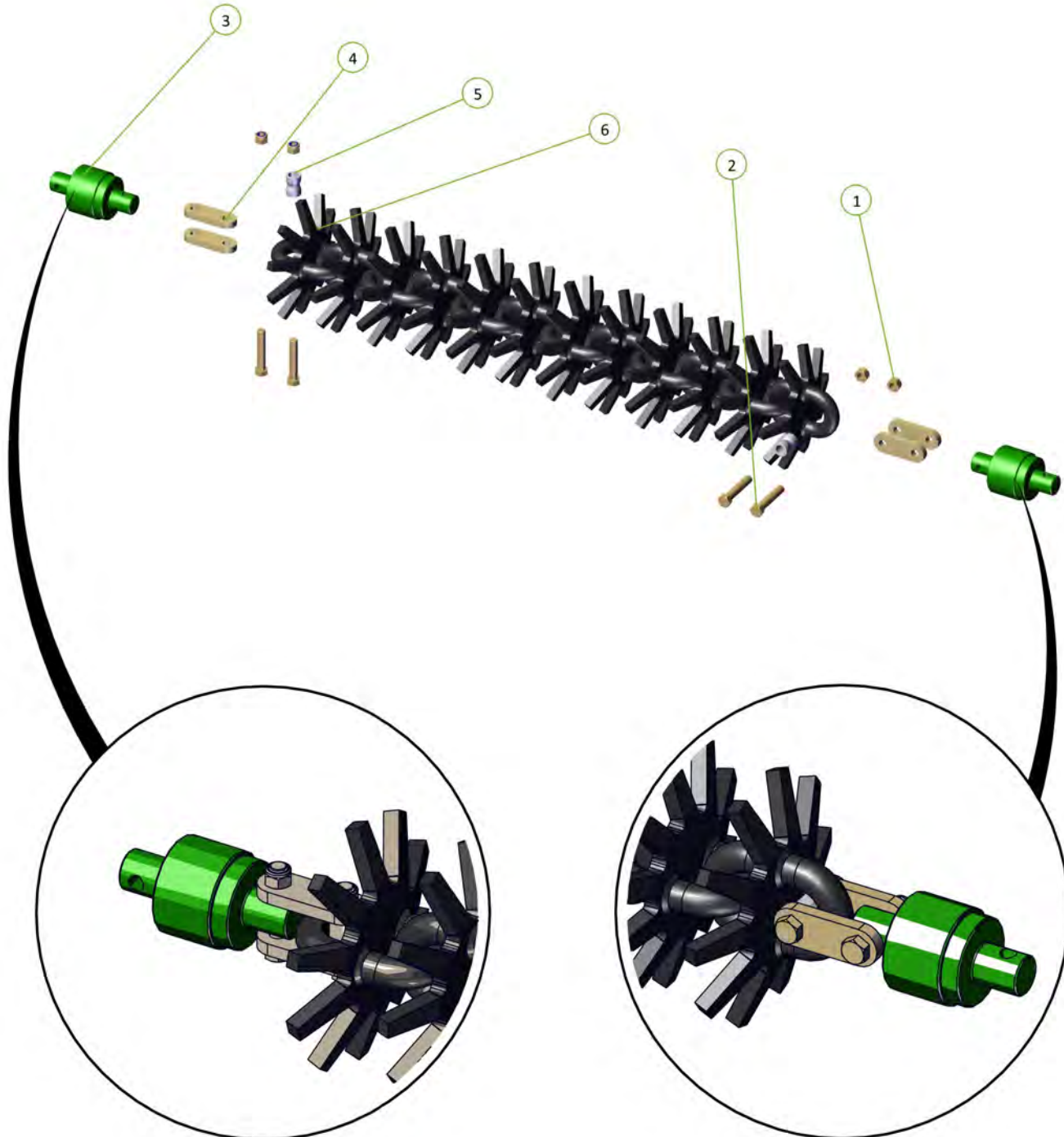

Item No.	Description	Number
1	Nyloc Nut M20	0221-NYL20
2	M20 x 110 Class 10.9 ZP Short Thread Bolt	0211-20110ST
3	20mm Bolt Swivel Unit	0802-PCHB55
4	0800-83.2	0800-83.2
5	Prickle Chain	0803-PCH

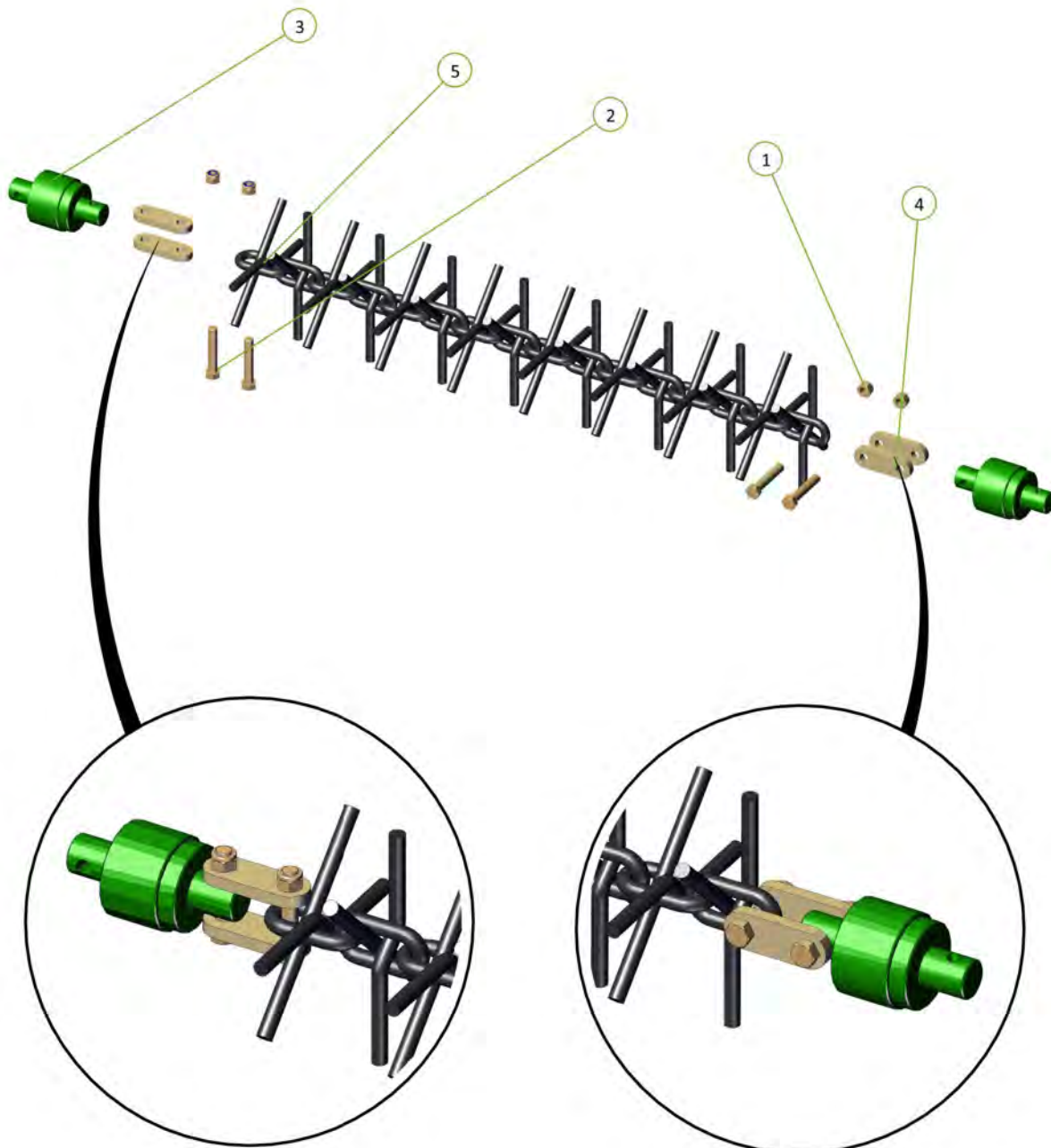
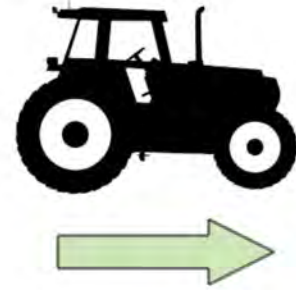



Section 6 - Specifications

Wiring Diagram

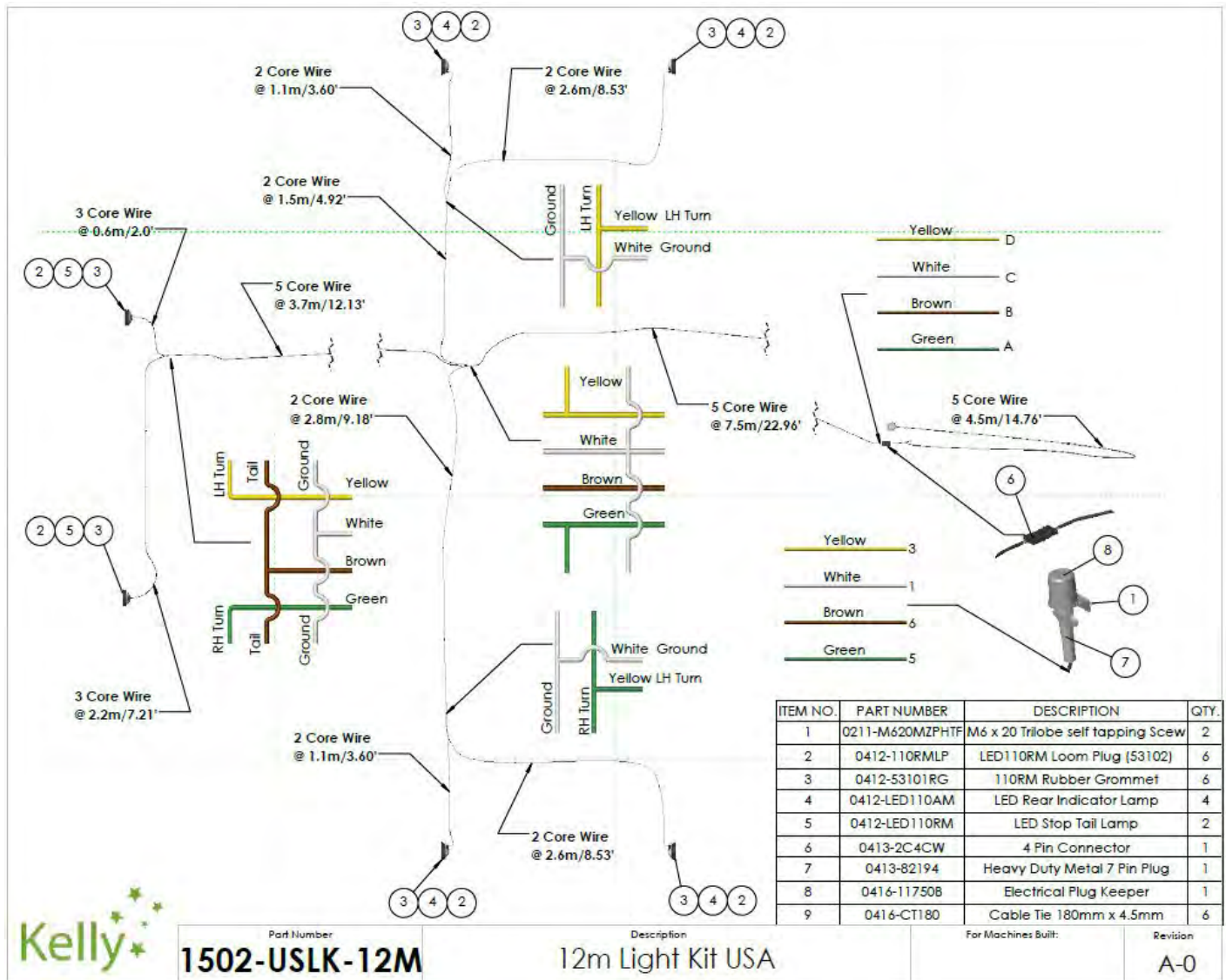

Part Number
1502-USLK-12M

Description
12m Light Kit USA

For Machines Built:

Revision

A-0

Mounting Swivels

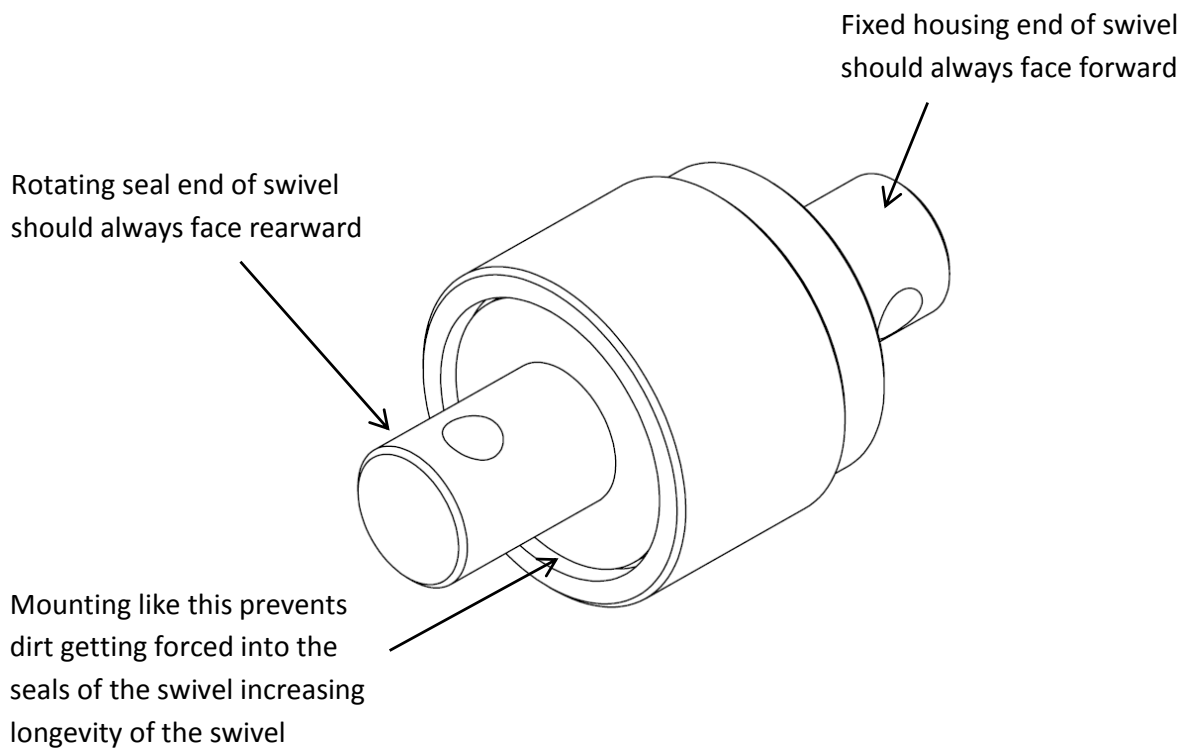

For Example

Swivels attached to the leading ends of the chains should have the rotating seal end attached to the chain like shown

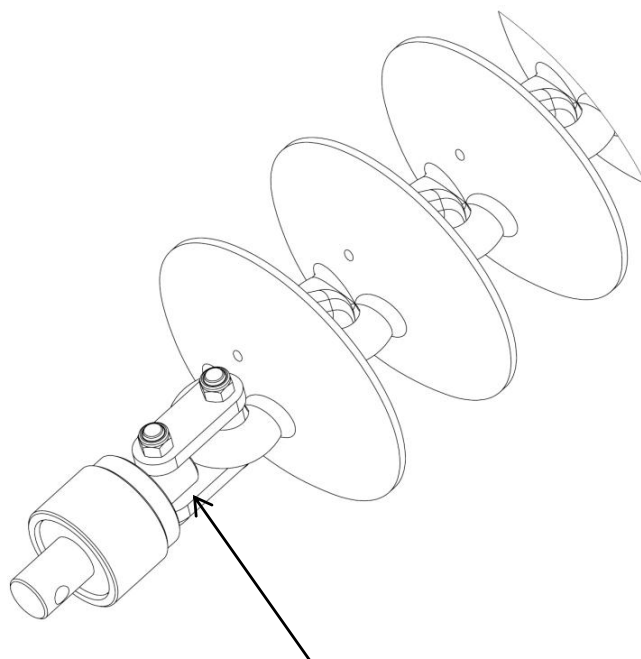
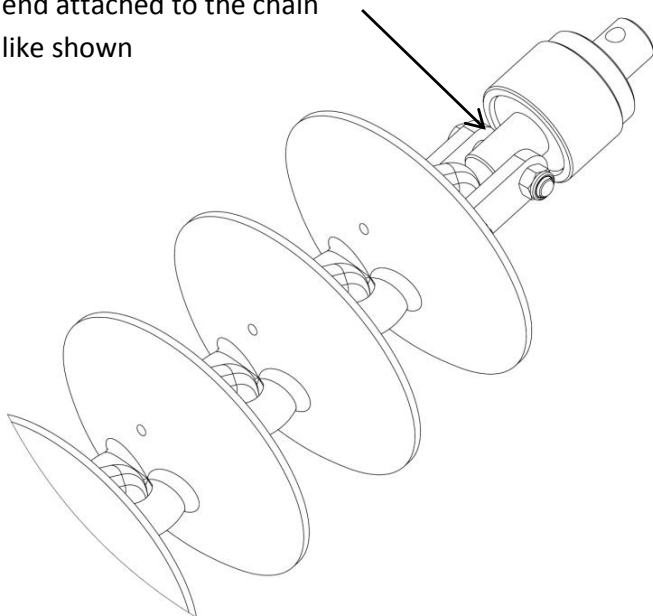

Swivels attached to the trailing ends of the chains should have the fixed housing end attached to the chain like shown

Operating speeds

Recommended operating speeds in normal conditions with all chain types	
Operating and working speeds	6-8 mph / 10-12 kph
Transporting / towing speed	15 mph / 25 kph

Tire Pressure

Tire size	Ply	PSI	KPA
400/55-22.5	18	50	350
11L/15	10	44	300

4012 specifications

Model 4012	All measurements are a guide only and may be +/- 1"
Operating width	12.93 m / 42'5.14"
Transport width	3.44 m / 11' 3.42"
Transport height	3.88 m / 12' 8.77"
Transport length	14.68 m / 48' 1.98"

Bolt Torque Settings

Bolt Type	Wheel nut					U Bolt 4.6				Grade 8.8 Bolt						Grade 10.9 Bolt		Grade 8 Bolt	
Bolt Size	M12	M18	M20	1/2"	9/16"	M10	M12	M16	M20	M6	M8	M10	M12	M16	M20	M24	M20	M24	1" UNF
Spanner	19	27	30	19	22	17	19	24	30	10	13	17	19	24	30	36	30	36	36
Ft lb	69	221	265	102	142	12	21	53	104	7	16	32	57	140	273	472	389	660	931
Nm	94	300	360	138	192	17	29	72	141	9	22	44	77	190	370	640	528	895	1262

[1] When fitting a wheel and tyre to a hub, tighten the wheel nuts in a star pattern to the correct tension. To achieve this, choose a wheel nut and tighten, then proceed to the opposite side of the hub to the next wheel nut and tighten and so on until all wheel nuts are tight. Then repeat the procedure to check that all nuts are tight. Do not use impact tools to tighten wheel nuts.

For a guide to the correct tension of the wheel nuts, please use the appropriate tension for your size wheel nuts from the Bolt Torque Settings table.

Torque values are for dry threads and surfaces however, it is permissible to apply a small amount of anti corrosive oil to the threads.

Verification and recording of the prescribed torque settings in the table above is the responsibility of the assembler and it shall be documented in accordance with their approved Quality Assurance system.

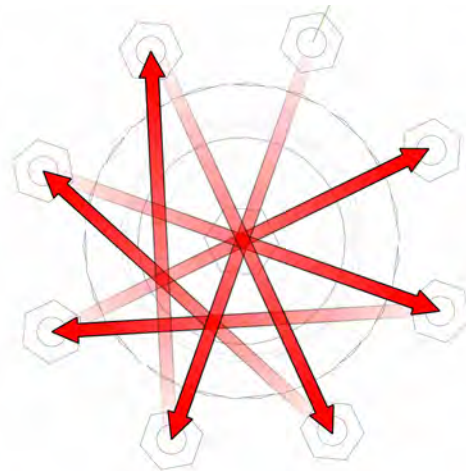

Disc Chains Lengths and Quantities

Model		Length	CL2	CL1	K4	W36	R300	SD49	Prickle chain
			CL2 disc chain also requires CL1 disc chain						
4012	Front right	23'5.69"/ 7.16m	CL2 - 32 CL1 - 2	44	45	42	57	57	79
	Front left	23'5.69"/ 7.16m	CL2 - 32 CL1 - 2	44	45	42	57	57	79
	Rear right	29'8.69"/ 9.06m	CL2 - 31 CL1 - 15	55	57	53	72	72	101
	Rear left	21'9.85"/ 6.65m	CL2 - 29 CL1 - 2	41	42	39	53	53	74
	Front module	8'6.09" / 2.59m	CL2 - 10 CL1 - 3	16	16	15	21	21	29
	Rear module	8'6.52" / 2.60m	CL2 - 10 CL1 - 2	16	16	15	21	21	29

For correct chain tension, chain links may need to be removed from the end of the chain as follows:

- CL2 Disc Chain - unhook disc chain link/s from end of the disc chain
- K4 Disc Chain - unhook disc chain link/s from end of the disc chain
- CL1 Disc Chain - unhook disc chain link/s from end of the disc chain
- Spiked Disc Chain - cut a disc chain link from the end of the disc chain
- R300 Disc Chain - cut a disc chain link from the end of the disc chain
- W36 Disc Chain - cut a disc chain link from the end of the disc chain
- Prickle Chain - cut a prickle chain link from the end of the prickle chain

Scan the following QR code to open the removing a welded disc chain video.





Section 7 - Operation

Basic Operation

Unfolding:

1. Walk around and inspect the machine.
 - a. Check that chains are not hooked on framework
 - b. Check swivel units are in place and not broken
 - c. Check that height adjusting chains have not fallen out of their slotted plates during transport.
 - d. Ensure front lift cylinder depth stops are fully engaged on cylinder shaft.
2. Lower front A frame to working height.
3. Unfold wings holding the hydraulic lever until both the main center cylinder pins have centered in their slots. (If chain pulls tight during unfold, stop and inspect if chain is hooked)
4. Lower rear tail by holding hydraulic lever until tail and modules are completely lowered to working position.
5. Walk around and check that all chain links are straight and that working height of all swivels is correct for field conditions. Adjust if necessary.
6. Move off with all chains in working position. If necessary it is acceptable to raise front A frame to transport height. This will lift the front chains off the ground and reduce the load on the tractor. Lower the front A frame once moving satisfactorily.

Folding:

1. Lower the front A frame at working height. (This is important to ensure that all chains locate correctly in their transport rests).
2. Raise the Rear Tail and modules by holding the hydraulic lever until they come to a complete stop.
3. Fold the wings. They should move as follows; main center cylinders will retract, one or both, until the wings stand vertically. The left outer wing then the right outer wing will fold down.
4. Raise front A frame to transport height.
5. Walk around and check that chains have located correctly in transport rests.

Importance of chain tension

Operational

Chain tension is critical to achieve a smooth and level seedbed. A correctly tensioned, monitored and maintained chain will deliver the results you need. Incorrect chain tension can lead to :

- Uneven results across the cut width of the machine
- Uneven weed control
- Unsatisfactory incorporation
- Ineffective levelling
- Accelerated or premature chain link wear (not covered by warranty)
- Chains failing to engage with transport locator's when folded
- Machine damage when folding or unfolding
- Uneven field surface with ridges and furrows being created.

A correctly adjusted machine will not cause this problem.

Chain Tension - Modules

1. Loosen the lock nut on the draw bolt.
2. Tighten the adjusting nut clockwise until the outer face of the spring retaining washer is pushed with the body of the module tensioning unit.
3. When 7-7/8" / 200mm or more of tensioner thread is visible then one link must be removed from the chain set to maintain correct tension adjustment. Spring length of 330mm / 1' 1" .
4. Retighten the lock nut.

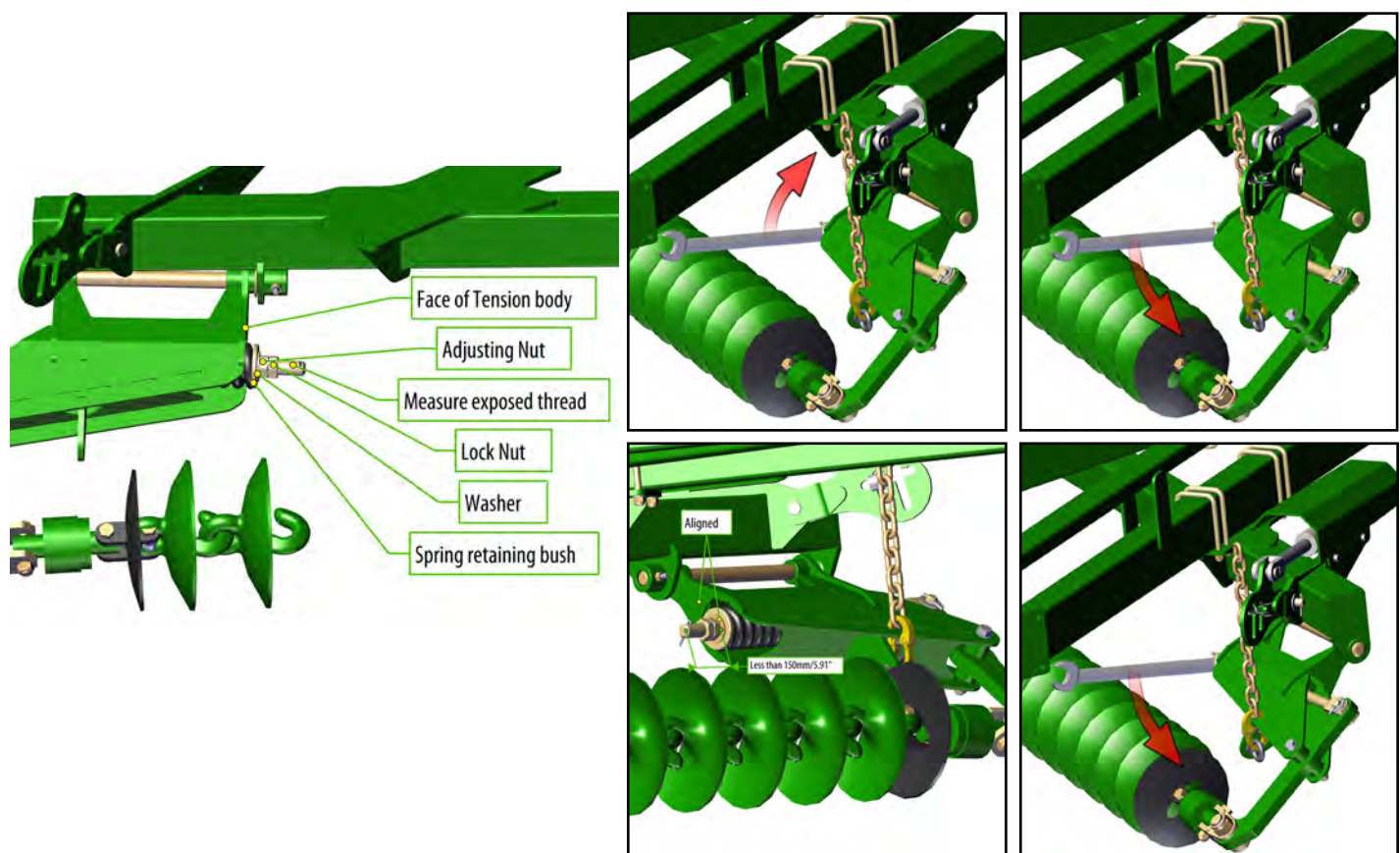

Chain Tension - Wings

- Use the spanner supplied to loosen the lock nut adjacent to the tensioner assembly body.
- Turn the module tension rod clockwise to compress the coil spring to the end of the indicator as shown, 330mm / 1' 1" . Correct tension is achieved when spring retains its set length when operator rolls the chain fore and aft on the ground.
- Retighten the lock nut.
- When less than 0.98" / 25mm of thread remains visible on the adjustor bolt then a link must be removed from the chain.

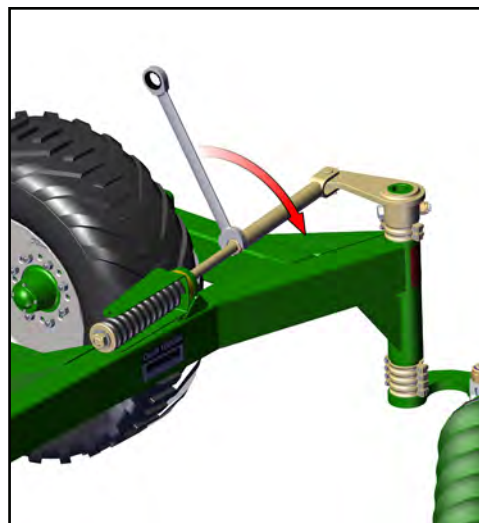
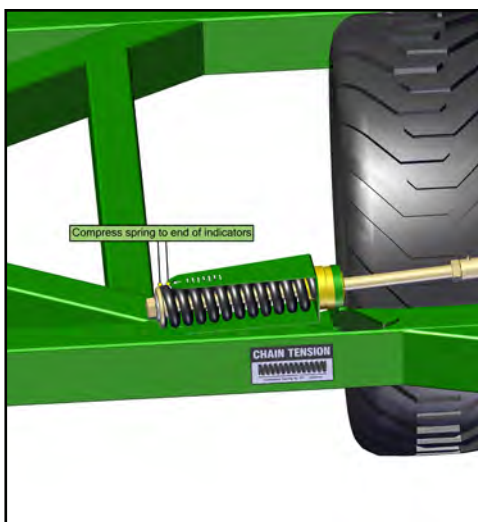
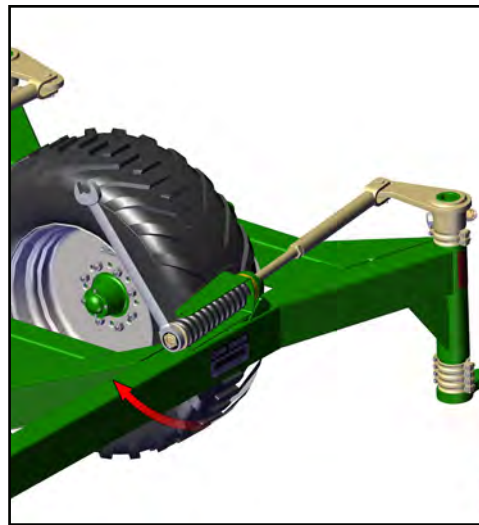
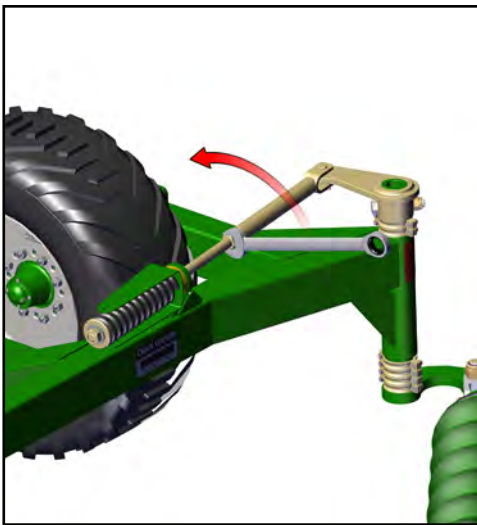

Correct Chain Height Adjustment

To adjust the swivel height at the wings, relocate one of the spacers either above or below the fixed mounting tube. Each Dropleg has four pairs of 0.98" / 25mm cast spacers. The most common set up is to have two pairs of cast spacers on the bottom and two pairs of cast spacers on the top. Below is the process to adjust the Dropleg height.

1	Loosen chain tension completely
2	Undo 2 x M10 bolts from corresponding spacer set and take the two halves off of the drop leg tube
3	Replace it in the selected position after raising or lowering the drop leg
4	Reinstall the M10 bolts and re-tension the chain

It is possible to install all spacers either above or below the mounting tube giving a maximum of 4" / 102 mm of adjustment.

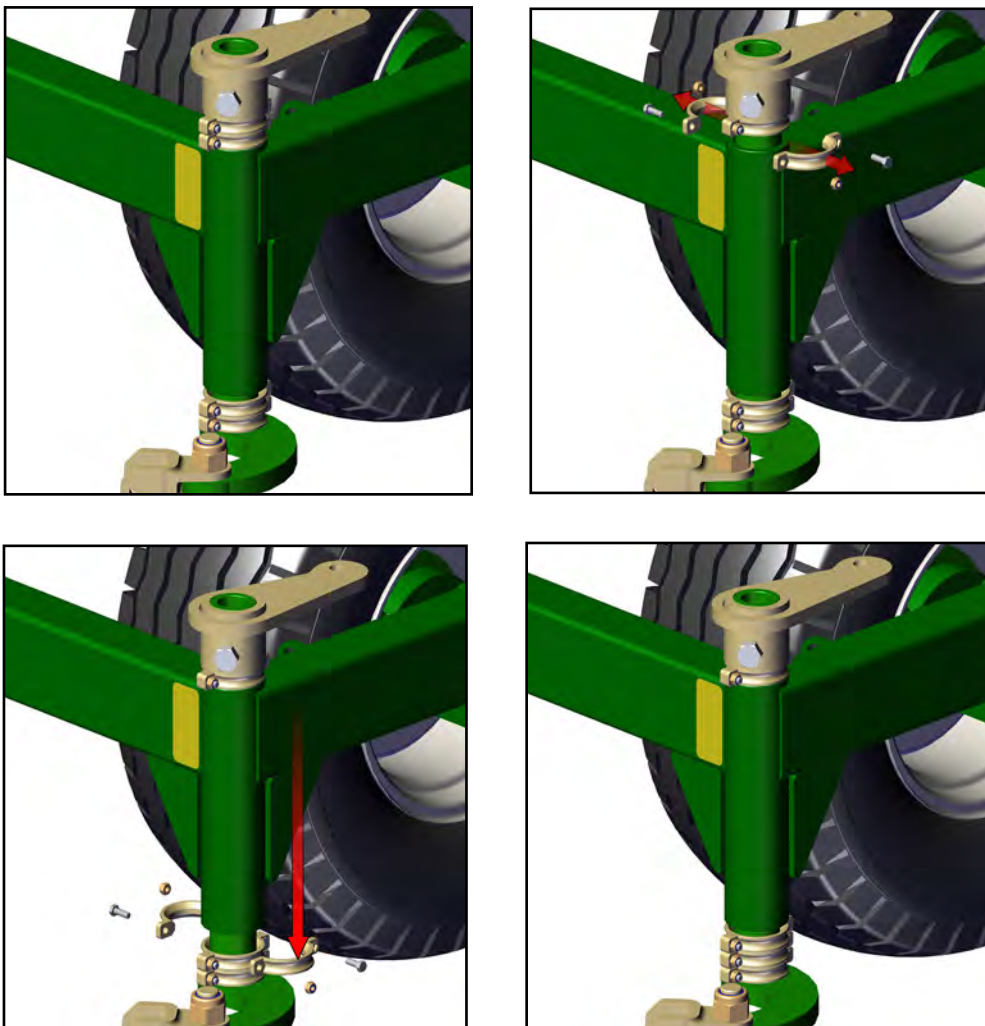



Notes



Phone +61 8 8667 2253
Email sales@kellytillage.com
kellytillage.com

Booleroo (Head Office)
684 Kelly Road,
Booleroo Centre SA 5482

Adelaide Office
28 Greenhill Road,
Wayville SA 5034

