

6m

Kelly

Tillage System 6m Assembly Manual

Revision C - March 2018

Serial Number:



Kelly Engineering
PO Box 100
Booleroo Centre
South Australia 5482
P +61 8 8667 2253
F +61 8 8667 2250
W kellyengineering.com.au

Thank you for choosing a Kelly Engineering product

We trust that you find the following manual clear and easy to follow. If you should require additional customer support or assistance, please do not hesitate to contact us.

Spare parts can be purchased, as required, through your local dealer or by contacting Kelly Engineering Australia or in the United States, Hood & Company.

Kelly Engineering welcomes feedback. Should you have any difficulties that you wish to raise, suggestions for improvement or modifications that you feel would enhance our products we look forward to hearing from you.

Australia

Kelly Engineering

PO Box 100

Boomeroo Centre SA 5482

Phone: + 61 8 8667 2253

Fax: + 61 8 8667 2250

Email: sales@kellyengineering.com.au

Spare Parts: parts@kellyengineering.com.au

Website: www.kellyengineering.com.au

United States

Kelly Engineering

Website: www.kellyharrows.com

Spare Parts

Hood & Company Inc

Springfield MO

Phone: 417 865 2100

Fax: 417 865 2105

Email: hoodco@hoodco.com

Contents

	Page Number
Section 1: Unpacking	4
Section 2: Assembly	7
Section 3: Hydraulics	5
Section 4: Diagrams & Specifications	95
Section 5: Assembly Updates	99



This symbol indicates which bag the relevant fasteners are in



This symbol indicates which bag the relevant hydraulics are in

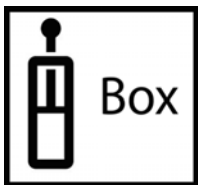

This symbol indicates the hydraulics are in a box

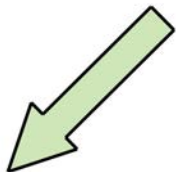

This symbol indicates which way the machine is travelling

Section 1

Unpacking

Unpacking

We recommend the use of suitable lifting equipment with a lifting capacity of at least 4 tones.



- Before unloading any loads please inspect exterior for damage



CAUTION

Take care when opening doors as load may have shifted or restraints may have broken.

- Remove boxes from doorway of container one at a time using a forklift truck. Each box weighs approximately (2600 lbs 1200kg)
- Check strapping on each bundle before attempting to remove
- Attach chains to the packing frame using shackles and using suitable equipment (eg. fork-lift or tractor) drag framework bundles out of container. To move bundles away from front of container lift from side with forklift. Do not lift under angle iron frame, lift only under centre frame. Each bundle weighs approximately 7000 lb (3200 kg).

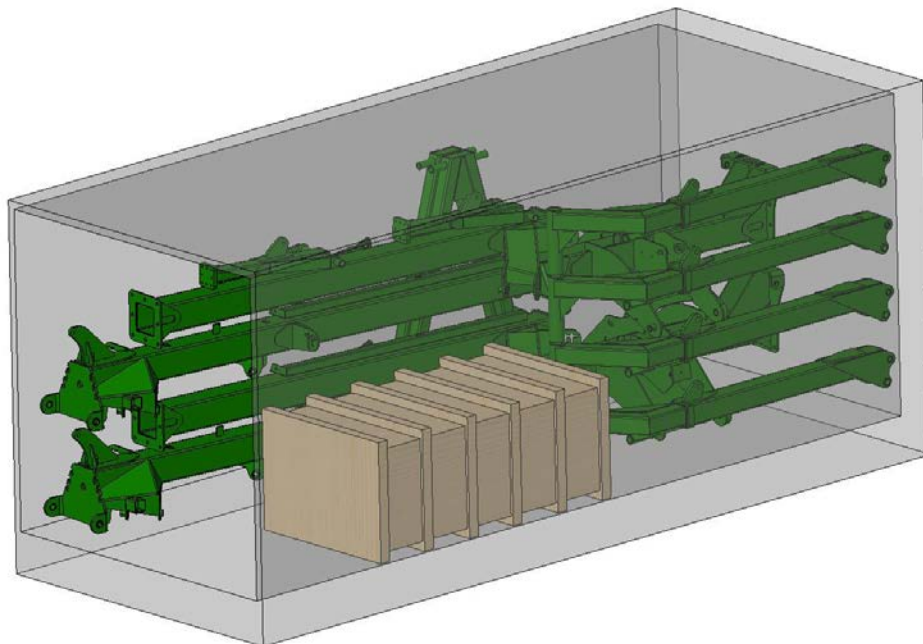

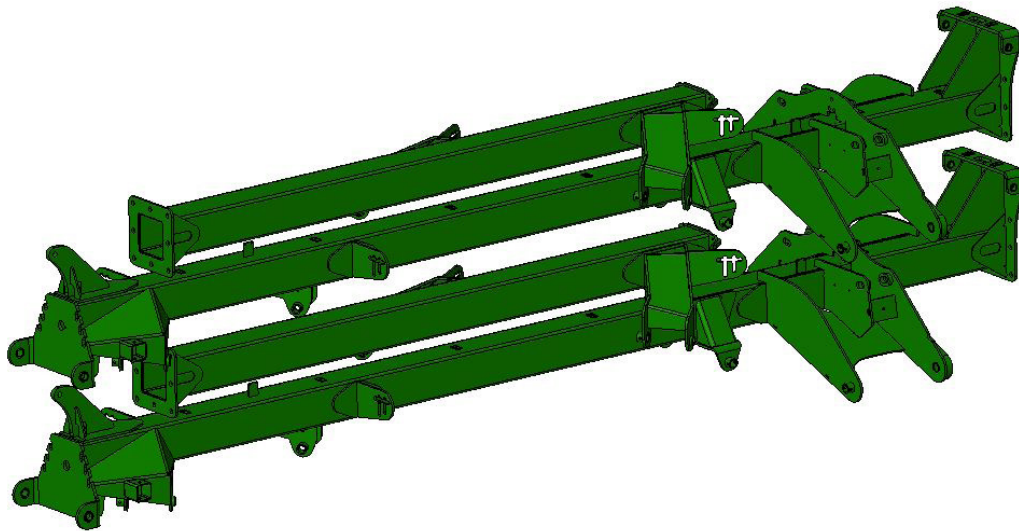

CAUTION

Before cutting straps attach slings or chains and take the weight of the frames to avoid them slipping or falling and causing injury.



CAUTION

Wear eye and hand protection when cutting straps. Sharp edges are exposed as straps separate and may cause injury.



CAUTION

To avoid falling or moving components, before cutting straps attach slings or chains to individual pieces and only cut the straps holding the piece to be lifted.

- Remove boxes from rear of container one at a time using a forklift truck. Each box weighs approximately 2600 lbs (1200 kg)
- Cut straps holding bundles and separate parts and place in assembly area
- Once all parts have been identified, the machine is ready for assembly
- Identify parts for each machine by serial no. or description and separate. Open parts box and check that all parts are accounted for against checklist
- Read assembly instructions before proceeding.

Section 2

Assembly

Item No.	Description	Qty	Number
1	M24 x 55 Grade 8.8 ZP Bolt	8	0211-2455
2	Nyloc Nut M24	8	0221-NYL24
3	6m Centre Section Frame	1	1520-01
4	6m Rear Section Frame	1	1520-03

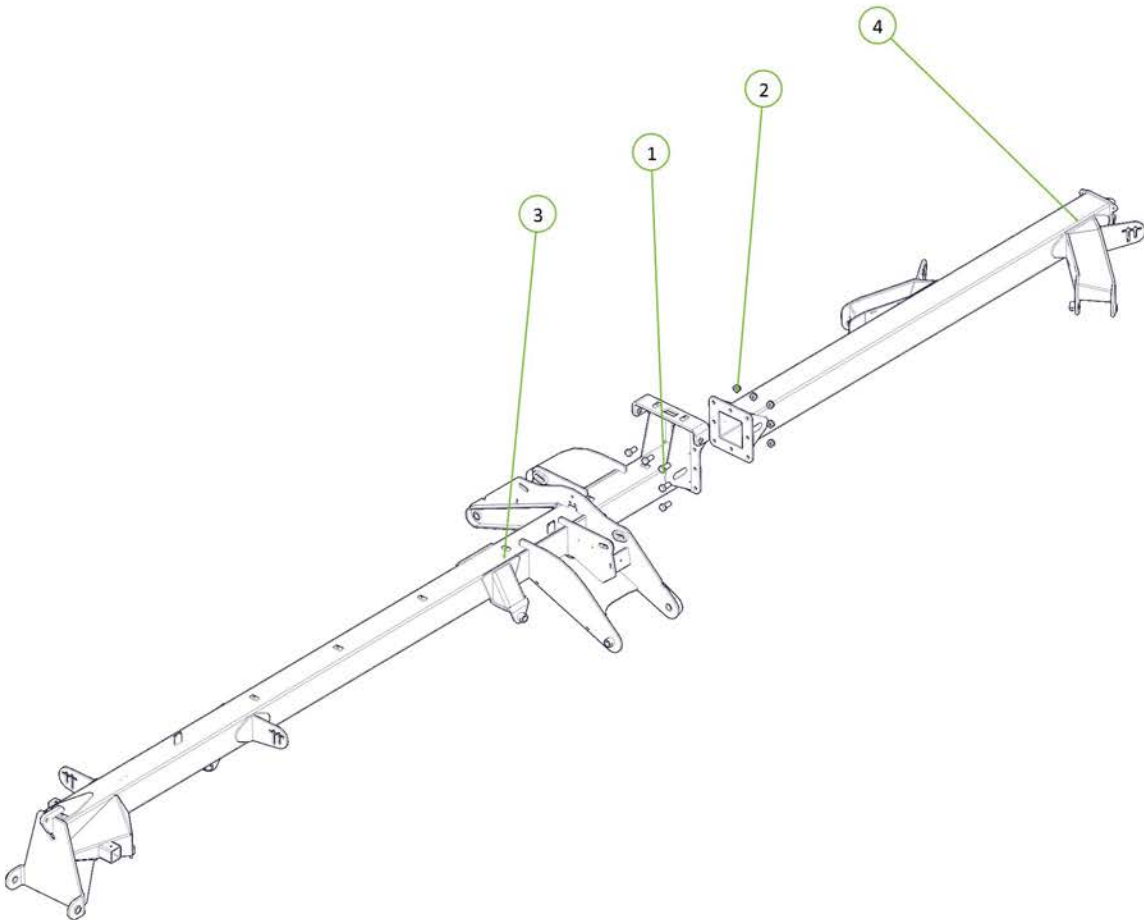

Item No.	Description	Qty	Number
1	M5 x 0.8 x 15mm Grade 4.6 ZP Bolt	2	0211-515
2	M5 Spring Washer	2	0231-S5
3	Wiring Capping Plate	1	1500-122

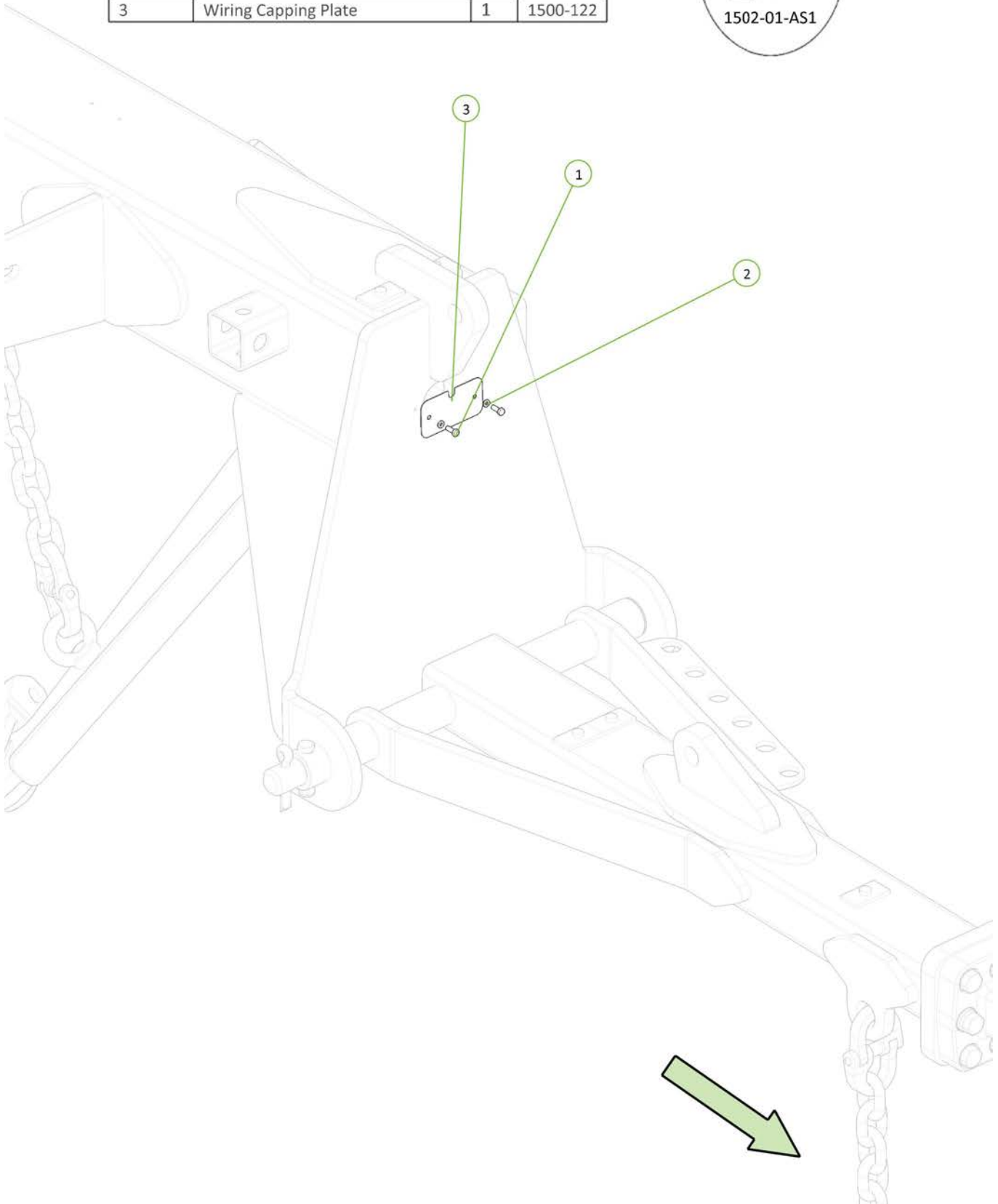

Item No.	Description	Qty	Number
1	M12 x 65 grade 8.8 ZP Bolt	1	0211-1265
2	Nyloc Nut M12	1	0221-NYL12
3	COTTER PIN M13 X 63mm	1	0261-PINC1363
4	Long Pivot Pin	1	1501-35615

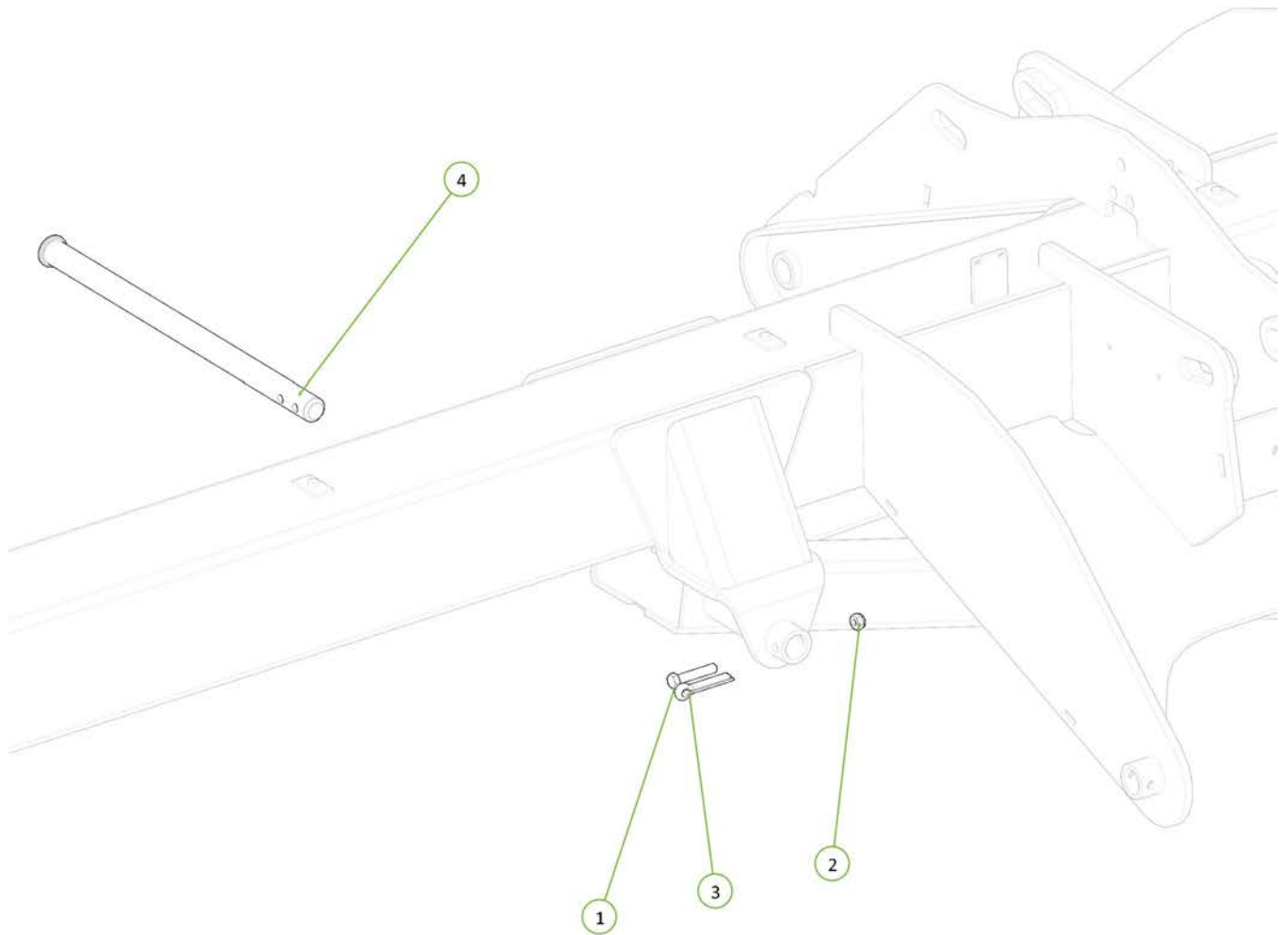

Item No.	Description	Qty	Number
1	M20 x 110 grade 8.8 ZP Bolt	2	0211-20110
2	Nyloc Nut M20	2	0221-NYL20
3	2.75"R C/W 6 tonne 8 on 8" PCD Complete Assembly	2	0733-SH27596880

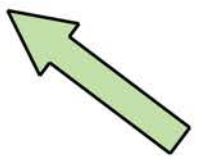
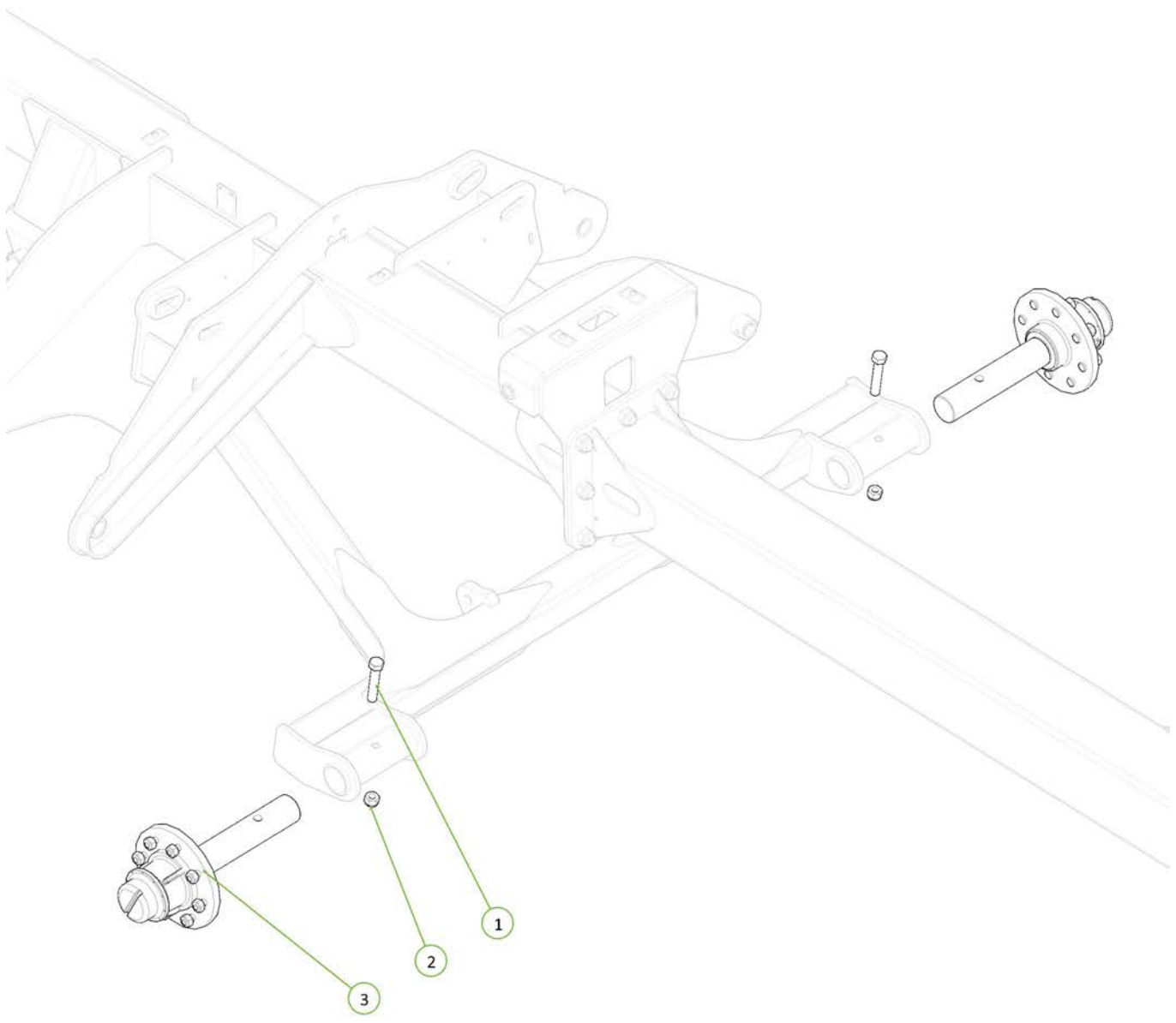

Item No.	Description	Qty	Number
1	11.5/80-15.3 tyre, 9" rim 0 offset, 8 on 8" studs, 162 cntr	2	0711-11.5-80-15.3

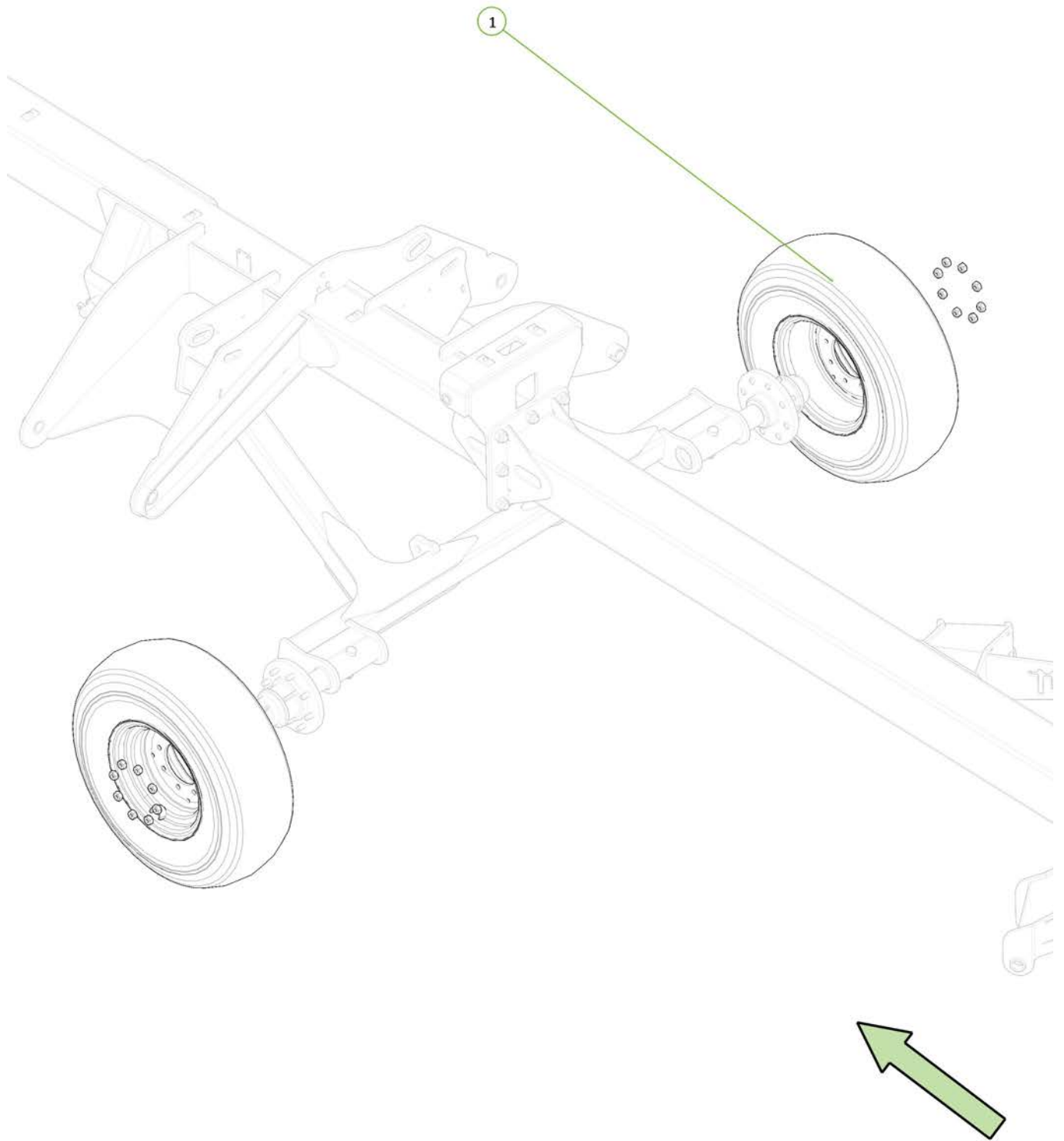

Item No.	Description	Qty	Number
1	Nordon 1" x 80mm Cylinder Pin	4	0313-N1
2	Nordon 1" Cylinder Pin Clip	8	0313-N1C
3	2.5" Bore x 16" Stroke Hydraulic Cylinder	2	0311-2516

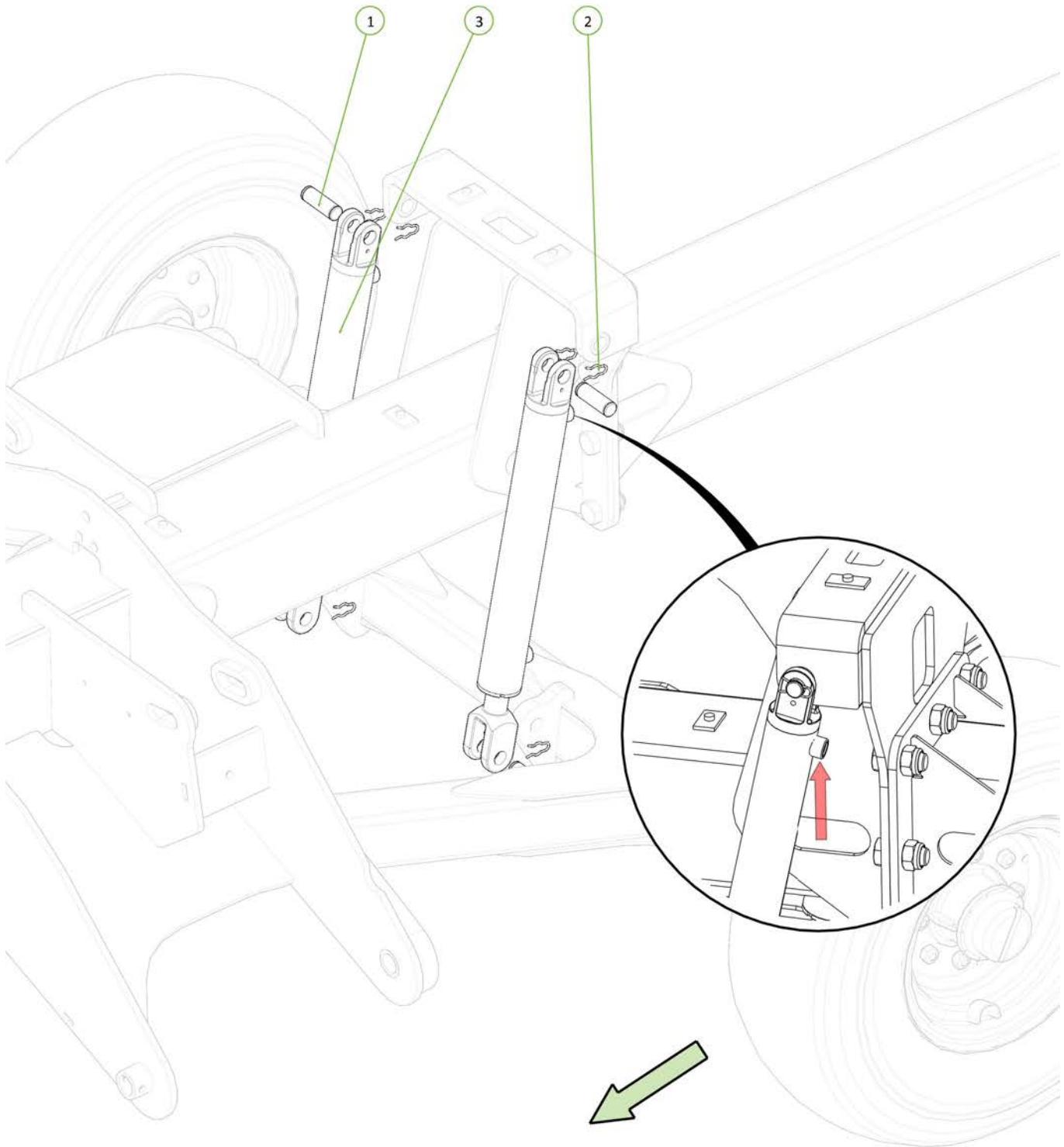

Item No.	Description	Qty	Number
1	6m Inner Wing Frame	1	1520-04
2	6m RH Outer Wing Frame	1	1520-06
3	2" Bore x 20" Stroke 1.75" Rod Single Acting Displacement Cylinder	1	0311-208SADC
4	6m Inner Bearing Pad	8	1501-IBP
5	TEK Phillips Wafer Head Metal Screw 10g x 16mm	40	0241-TEKWH16
6	CIRCLIP Internal 26mm	2	0171-26
7	Wing Tension Pin 2	1	1501-25118

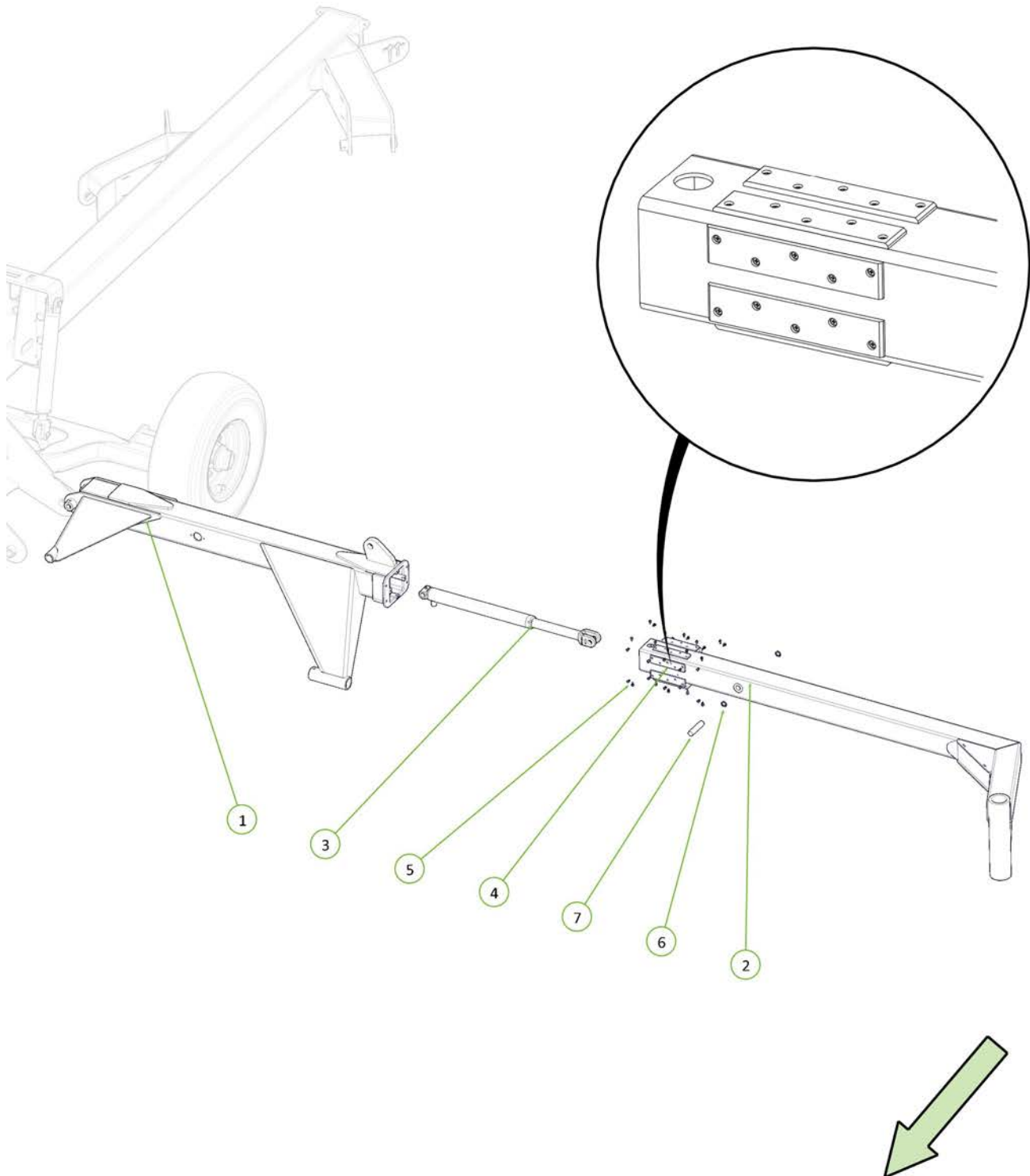

Item No.	Description	Qty	Number
1	6m Outer Bearing Pad	8	1501-OBP
2	Inner Wing Wear Pad Retainer	2	1500-289
3	M12 x 35 grade 8.8 ZP Bolt	4	0211-1235
4	Nyloc Nut M12	4	0221-NYL12

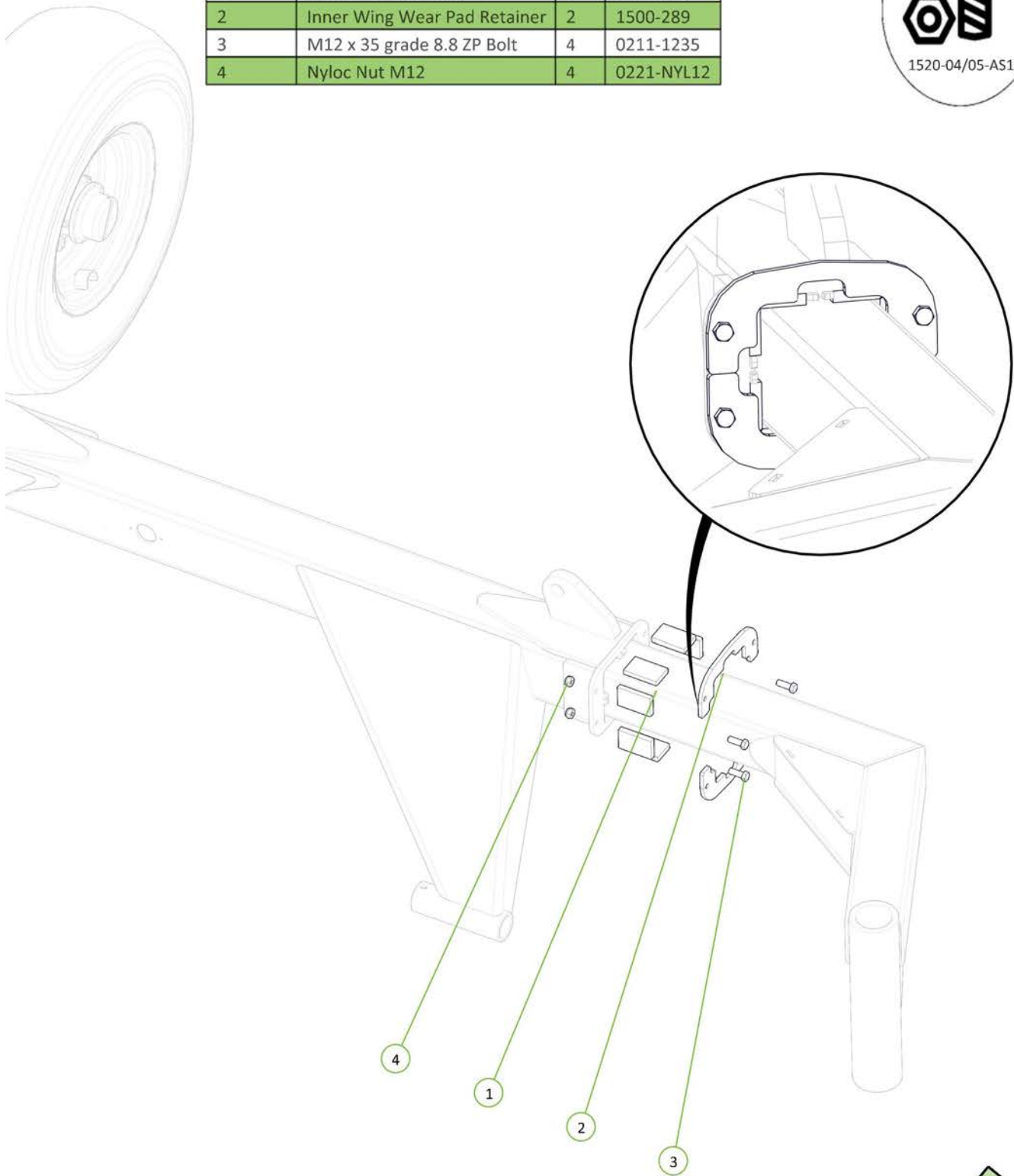

Item No.	Description	Qty	Number
1	6m Pin Access Cap	2	1500-300
2	M6 x 12mm Pan Pozilobular T/F Screw Zinc	4	0211-M612-92064151
3	Washer Flat M6	4	0231-F6
4	Washer Spring M6	4	0231-S6

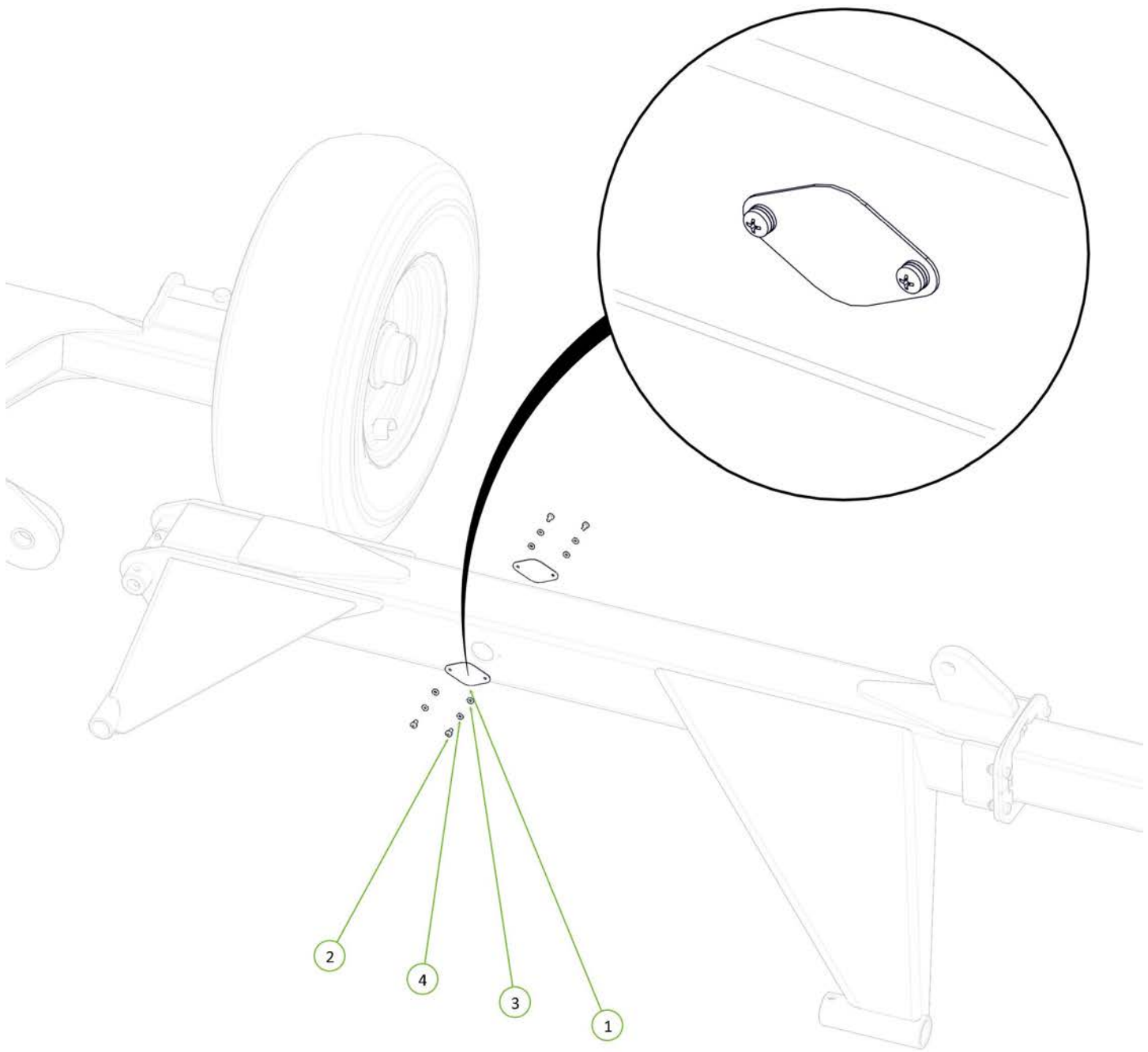

Item No.	Description	Qty	Number
1	Wing Tension Pin	1	1501-25214
2	35 ID x 50mm DU Bush	2	0113-MB 3550DU
3	Nyloc Nut M12	1	0221-NYL12
4	M12 x 70 grade 8.8 ZP Bolt	1	0211-1270

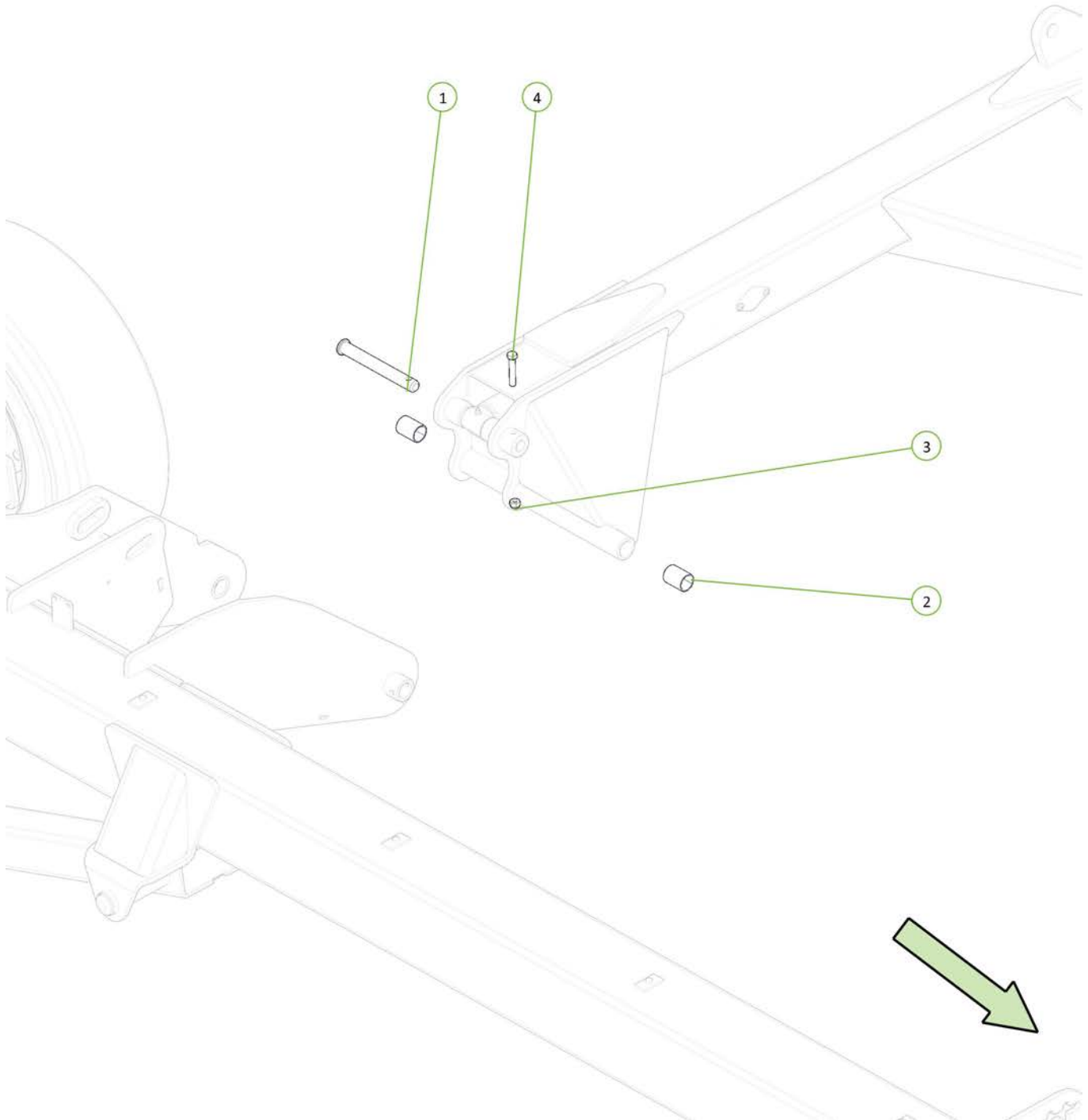

Item No.	Description	Qty	Number
1	M12 x 65 grade 8.8 ZP Bolt	1	0211-1265
2	Nyloc Nut M12	1	0221-NYL12
3	COTTER PIN M13 X 63mm	1	0261-PINC1363
4	Long Pivot Pin	1	1501-35615

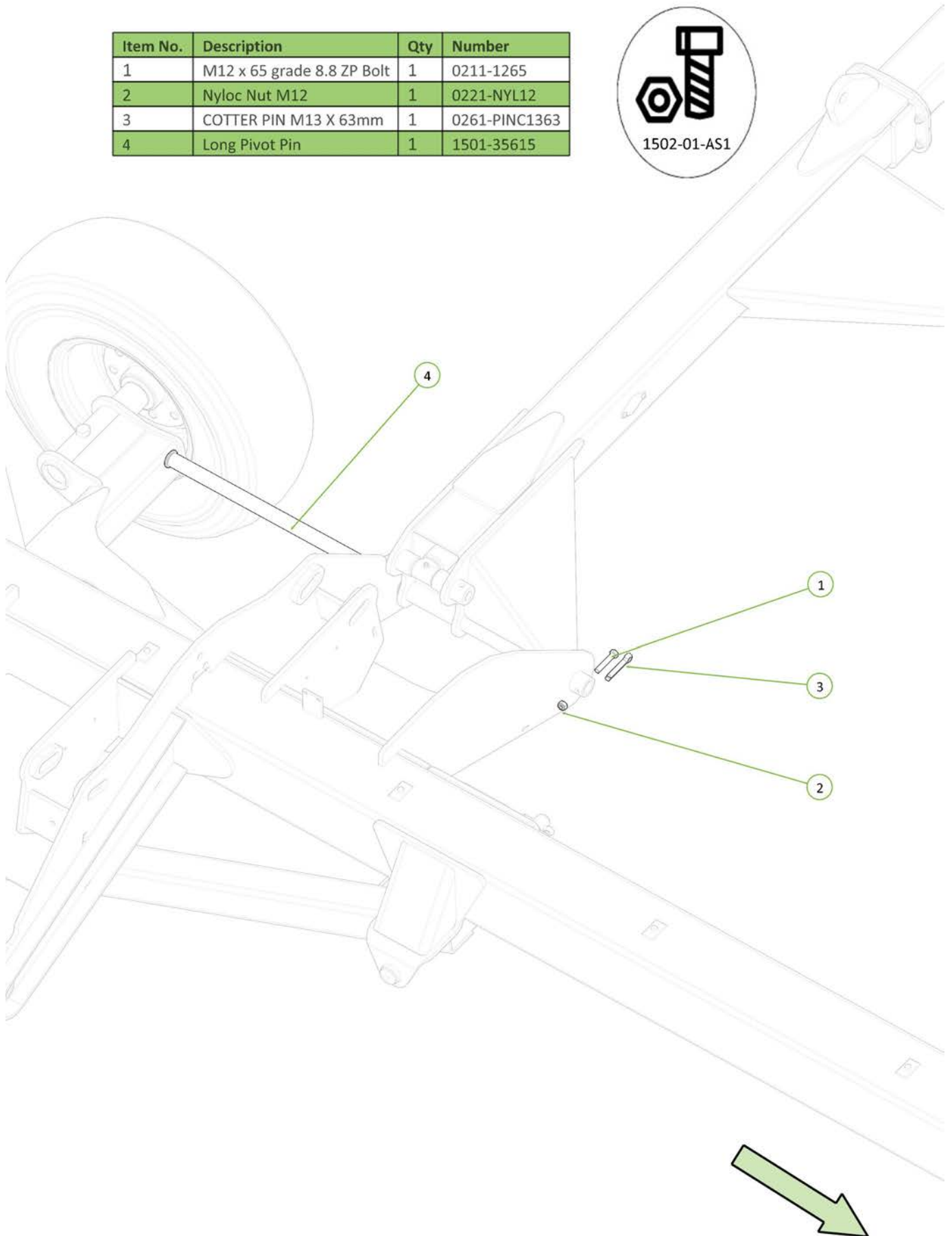

Item No.	Description	Qty	Number
1	M16 x 90 grade 8.8 zp Bolt	1	0211-1690
2	Nyloc Nut M16	1	0221-NYL16
3	Axle 2"R 3T 6 on 6"PCD 330 OHF Complete Assembly	1	0733-K5083T66S
4	11L15F3 tyre On Rim	1	0721-15X8

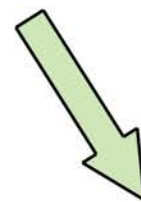
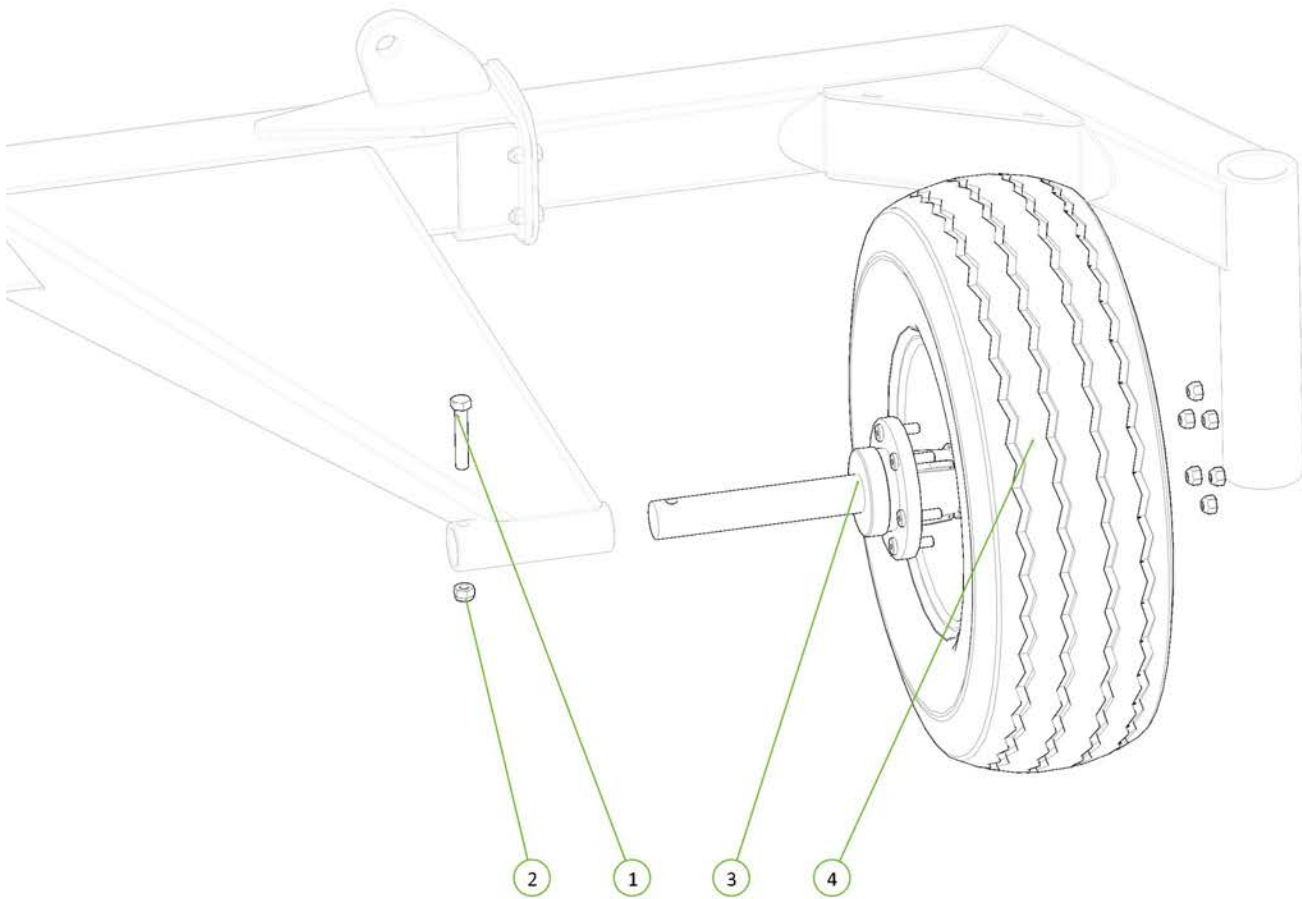

Item No.	Description	Qty	Number
1	LH Drop Leg	1	1510-25
2	M16 x 130 grade 8.8 zp Bolt	1	0211-16130
3	Nyloc Nut M16	1	0221-NYL16
4	Drop Leg Retaining Bush	1	1501-26

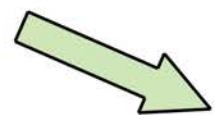
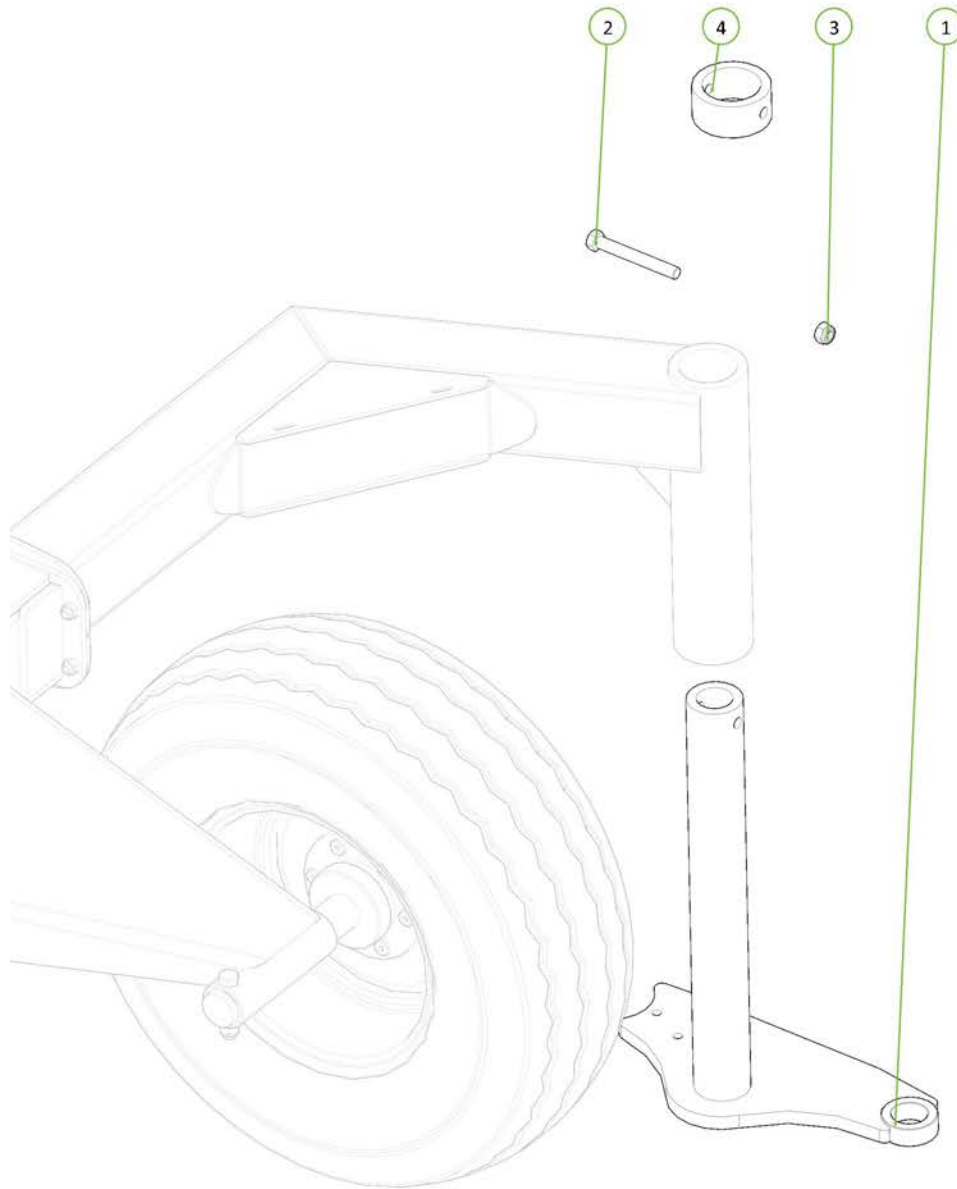

Item No.	Description	Qty	Number
1	Drop Leg Spacer Plate	1	1500-095
2	Drop Leg Bush Housing	1	1510-23
3	Nyloc Nut M12	3	0221-NYL12
4	M12 x 70 grade 8.8 ZP Bolt	3	0211-1270

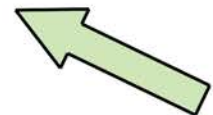
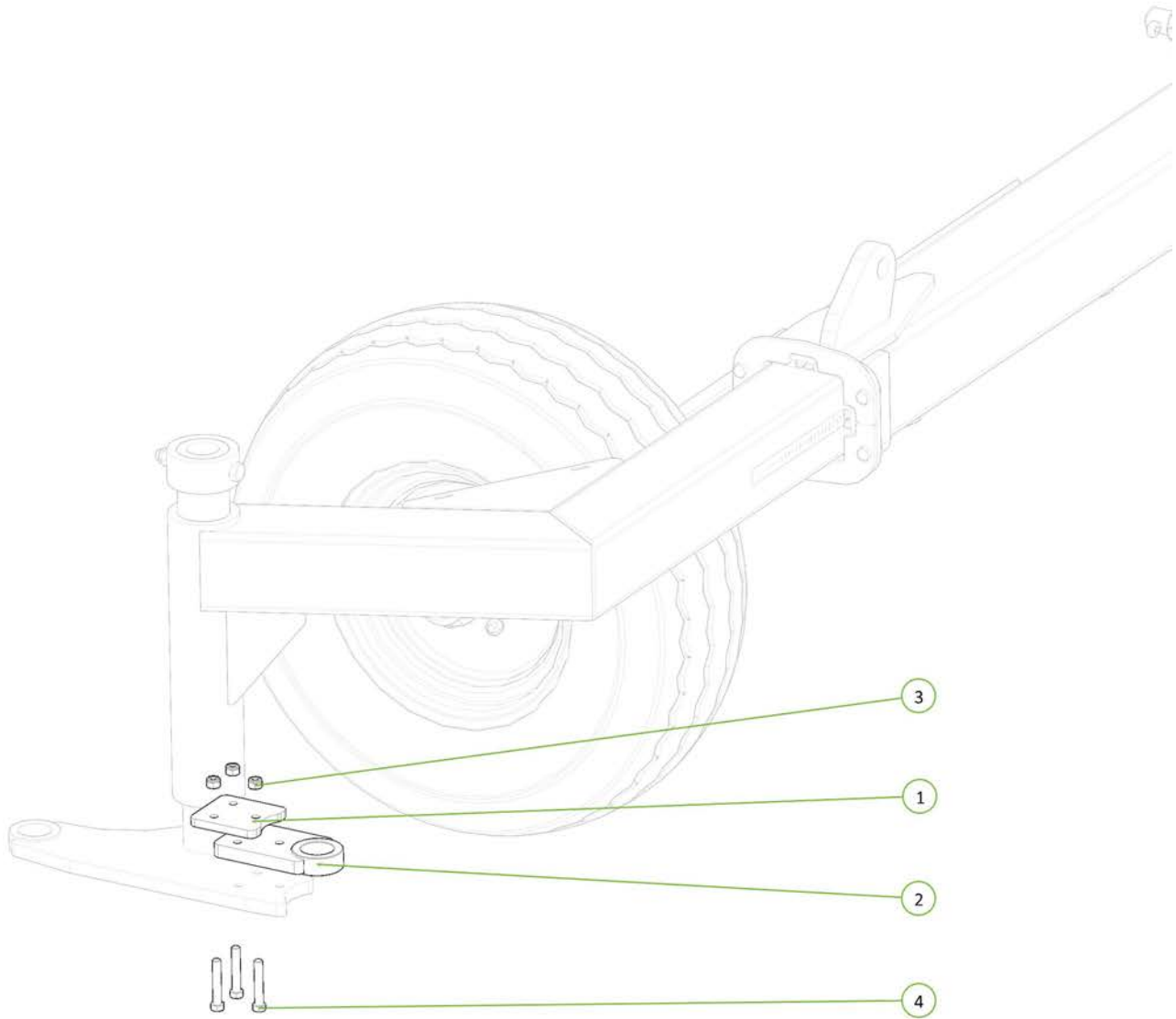

Item No.	Description	Qty	Number
1	Forged Clevis 21mm Bolt Hole	2	0801-FC21
2	Nyloc Nut M36	2	0221-NYL36
3	M36 x 105 grade 8.8 ZP Bolt	2	0211-36105
4	Wear Bush	2	1501-365033-SS

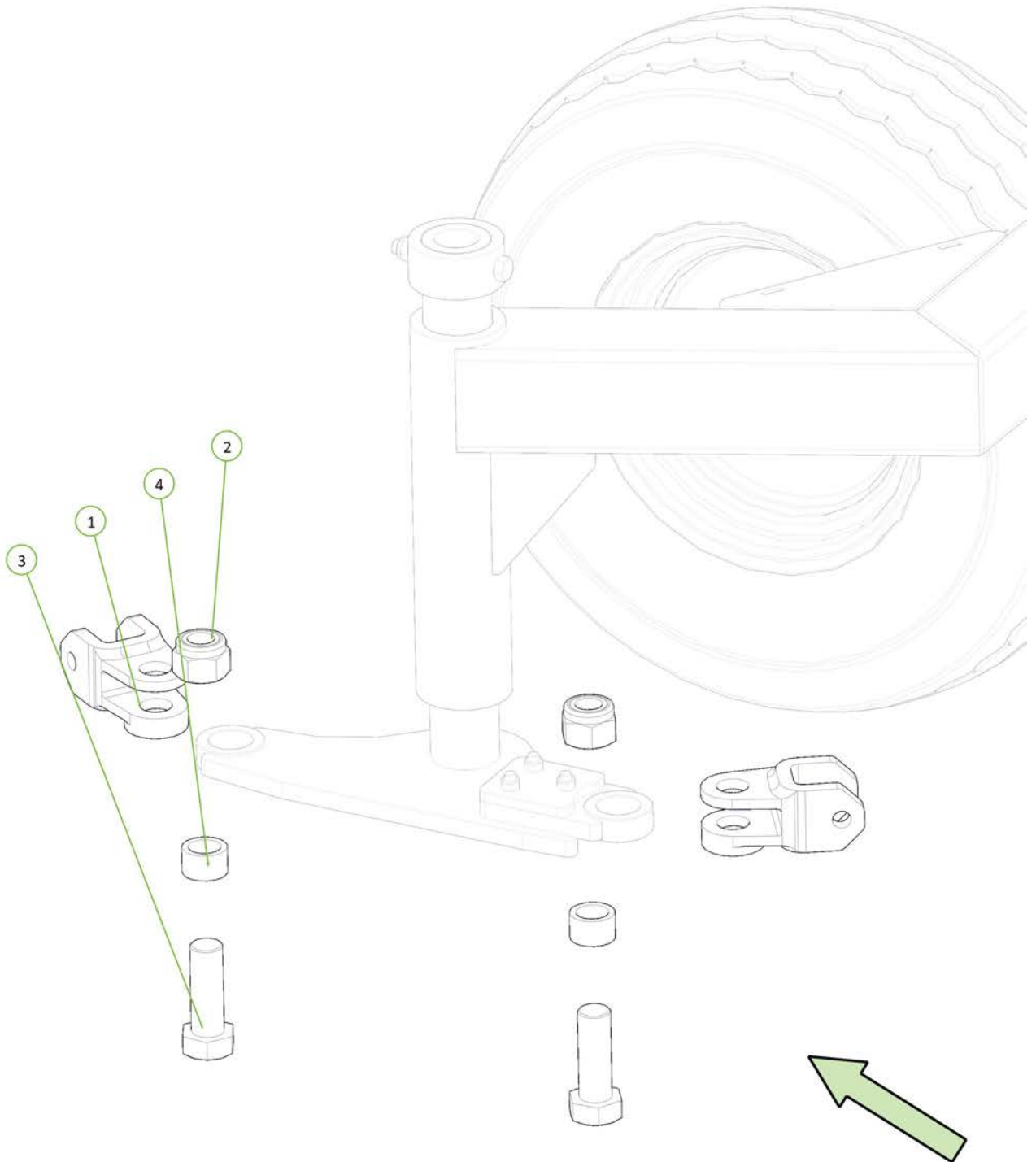

Item No.	Description	Qty	Number
1	M10 x 30 grade 8.8 ZP Bolt	10	0211-1030
2	Nyloc Nut M10	10	0221-NYL10
3	25mm Drop Leg Spacer Half	10	0801-CS25

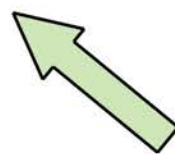
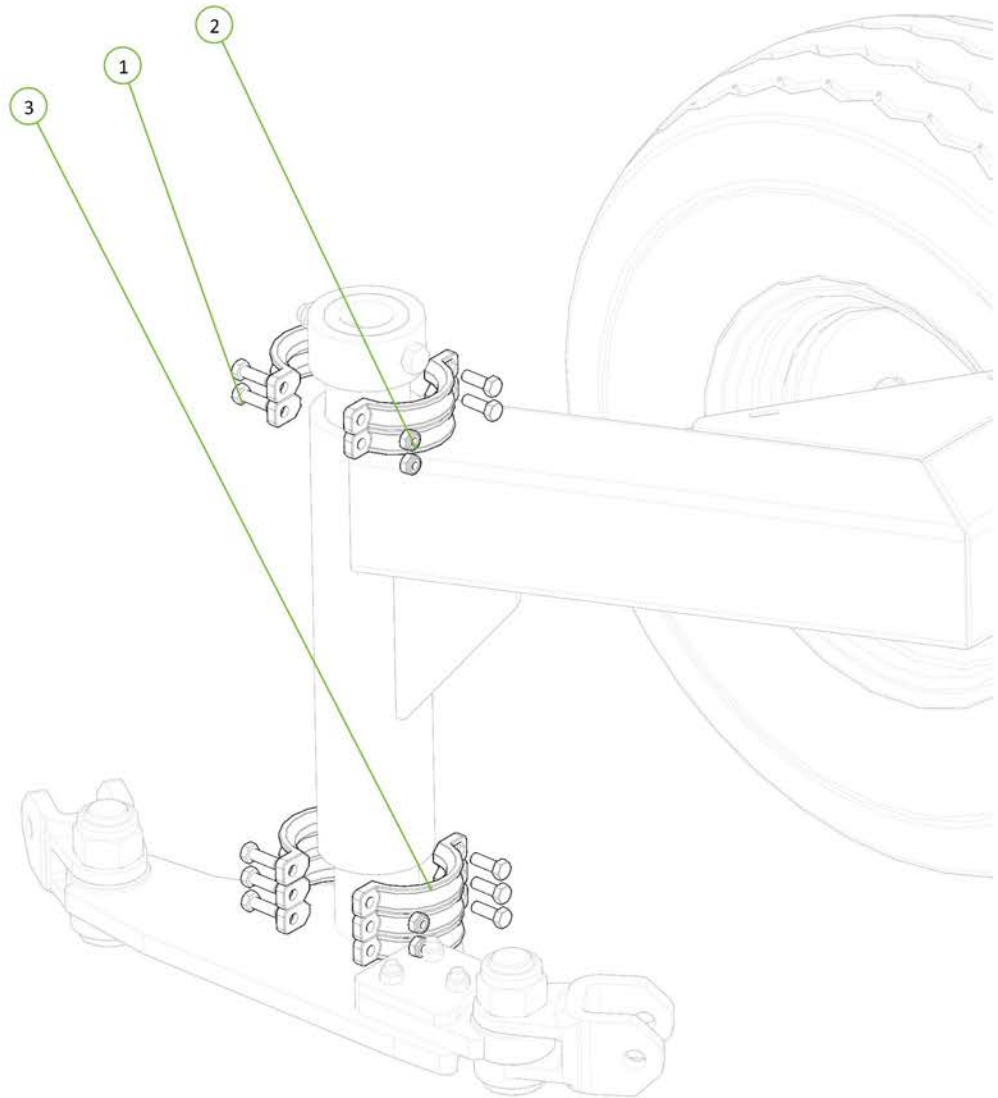

Item No.	Description	Qty	Number
1	Long Pivot Pin	1	1501-35615
2	COTTER PIN M13 X 63mm	1	0261-PINC1363
3	M12 x 65 grade 8.8 ZP Bolt	1	0211-1265
4	Nyloc Nut M12	1	0221-NYL12

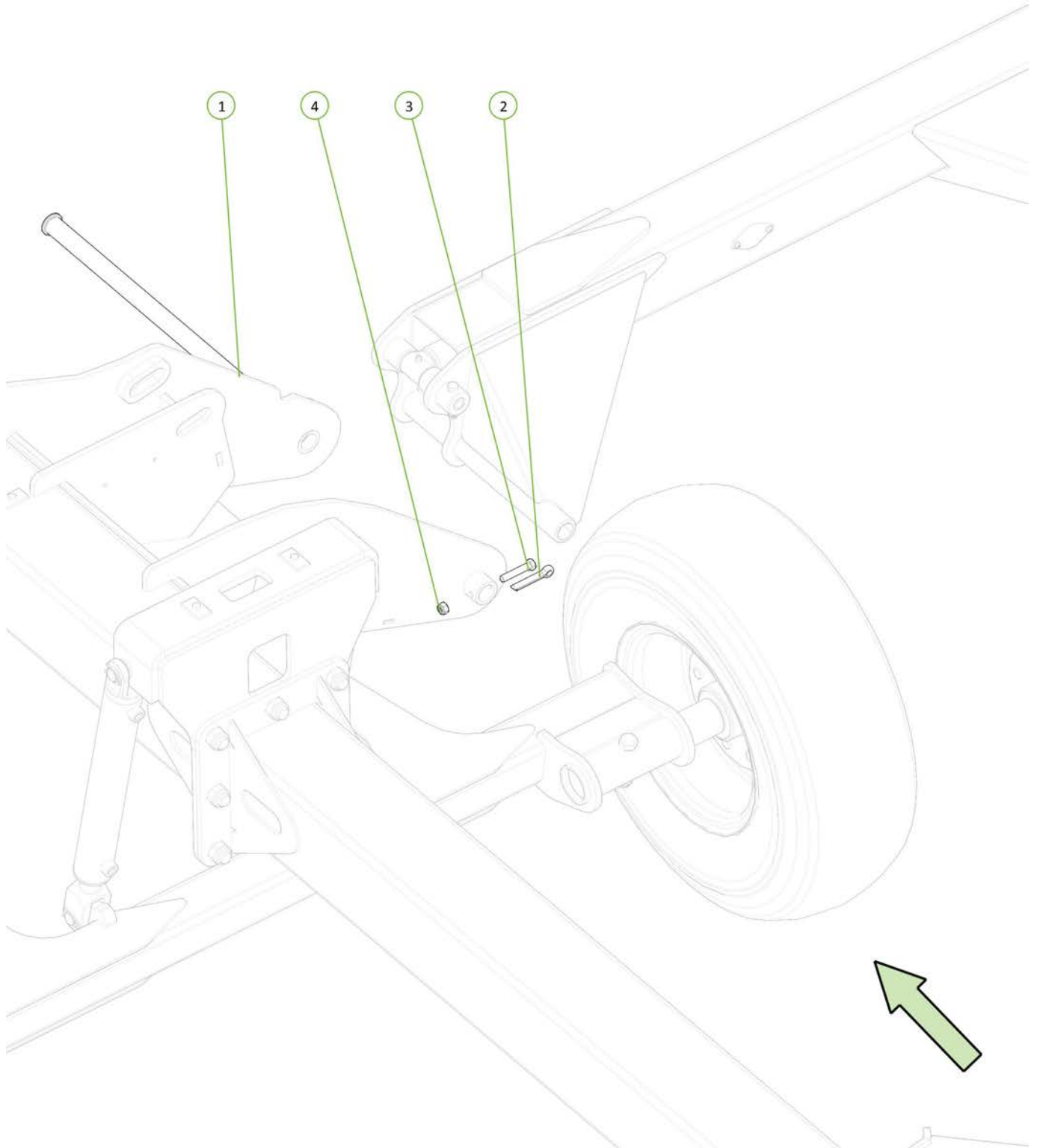

Item No.	Description	Qty	Number
1	M16 x 90 grade 8.8 zp Bolt	1	0211-1690
2	Nyloc Nut M16	1	0221-NYL16
3	Axle 2"R 3T 6 on 6"PCD 330 OHF Complete Assembly	1	0732-K5083TS
4	Rim Only 15" Diameter 8" Wide, 6 on 6" PCD, 118mm Bore, +30 Offset	1	0721-15X8

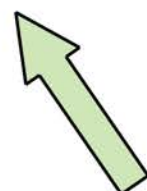
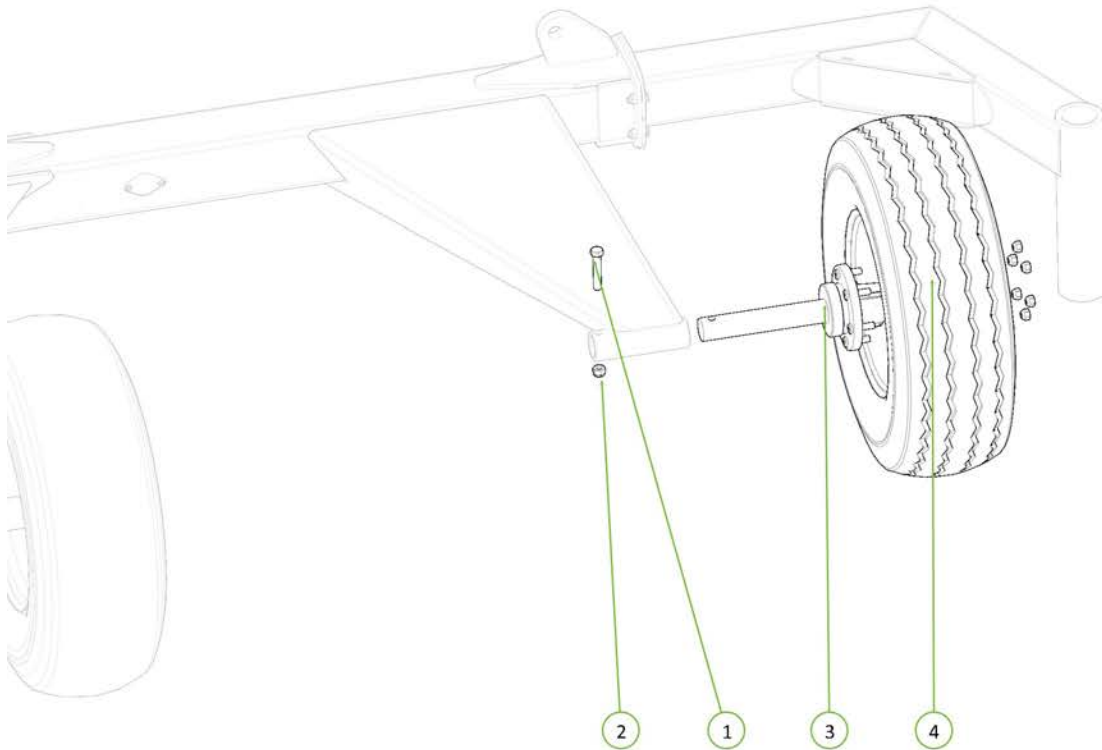

Item No.	Description	Qty	Number
1	M16 x 130 grade 8.8 zp Bolt	1	0211-16130
2	Nyloc Nut M16	1	0221-NYL16
3	Nyloc Nut M12	3	0221-NYL12
4	M12 x 70 grade 8.8 ZP Bolt	3	0211-1270
5	Drop Leg Spacer Plate	1	1500-095
6	Drop Leg Bush Housing	1	1510-23
7	Drop Leg Retaining Bush	1	1501-26
8	RH Drop Leg	1	1510-24

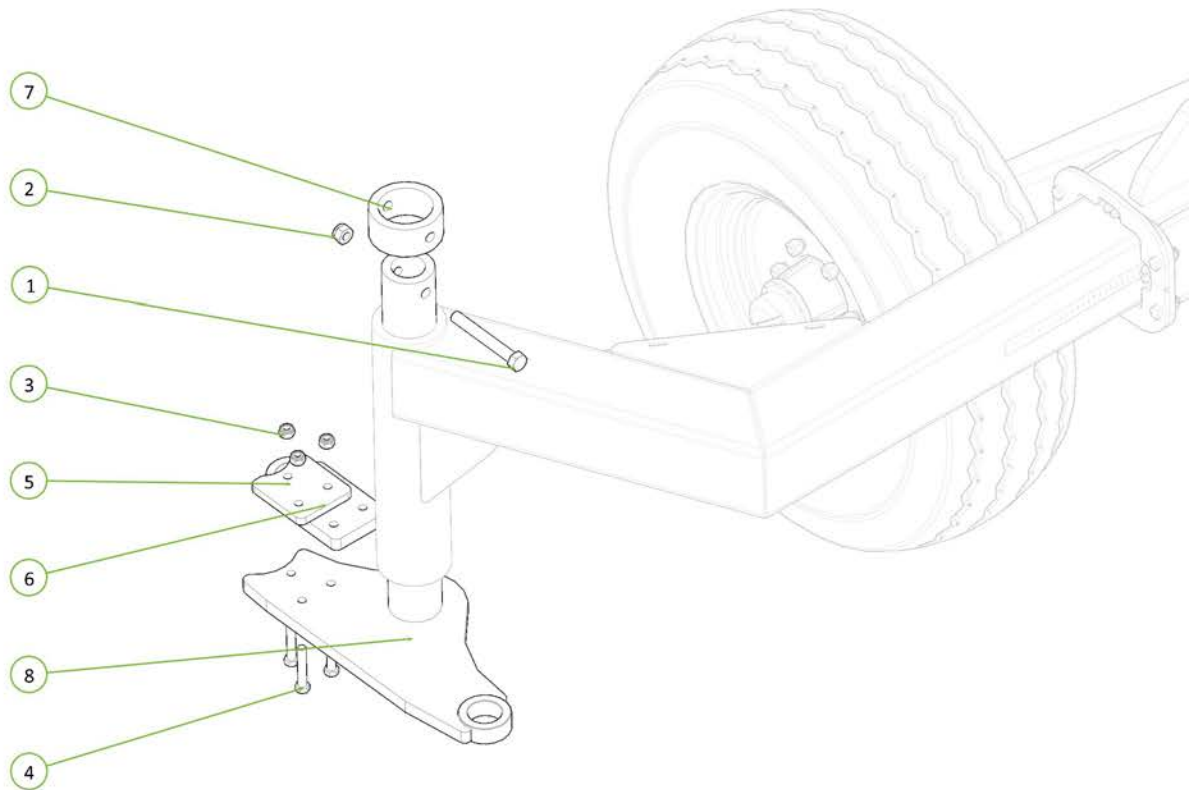

Item No.	Description	Qty	Number
1	Forged Clevis 21mm Bolt Hole	2	0801-FC21
2	M36 x 105 grade 8.8 ZP Bolt	2	0211-36105
3	Nyloc Nut M36	2	0221-NYL36
4	Wear Bush	2	1501-365033-SS

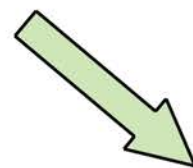
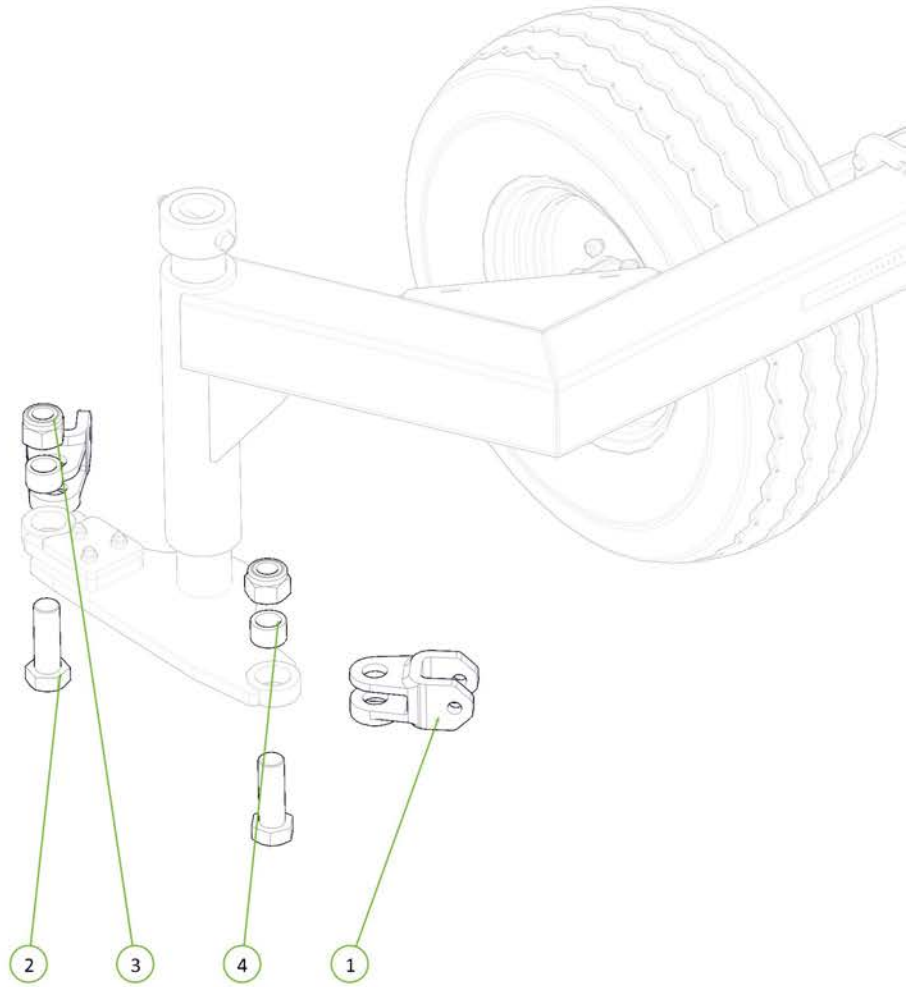

Item No.	Description	Qty	Number
1	25mm Drop Leg Spacer Half	10	0801-CS25
2	M10 x 30 grade 8.8 ZP Bolt	10	0211-1030
3	Nyloc Nut M10	10	0221-NYL10

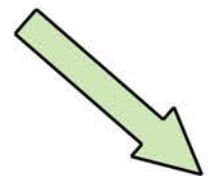
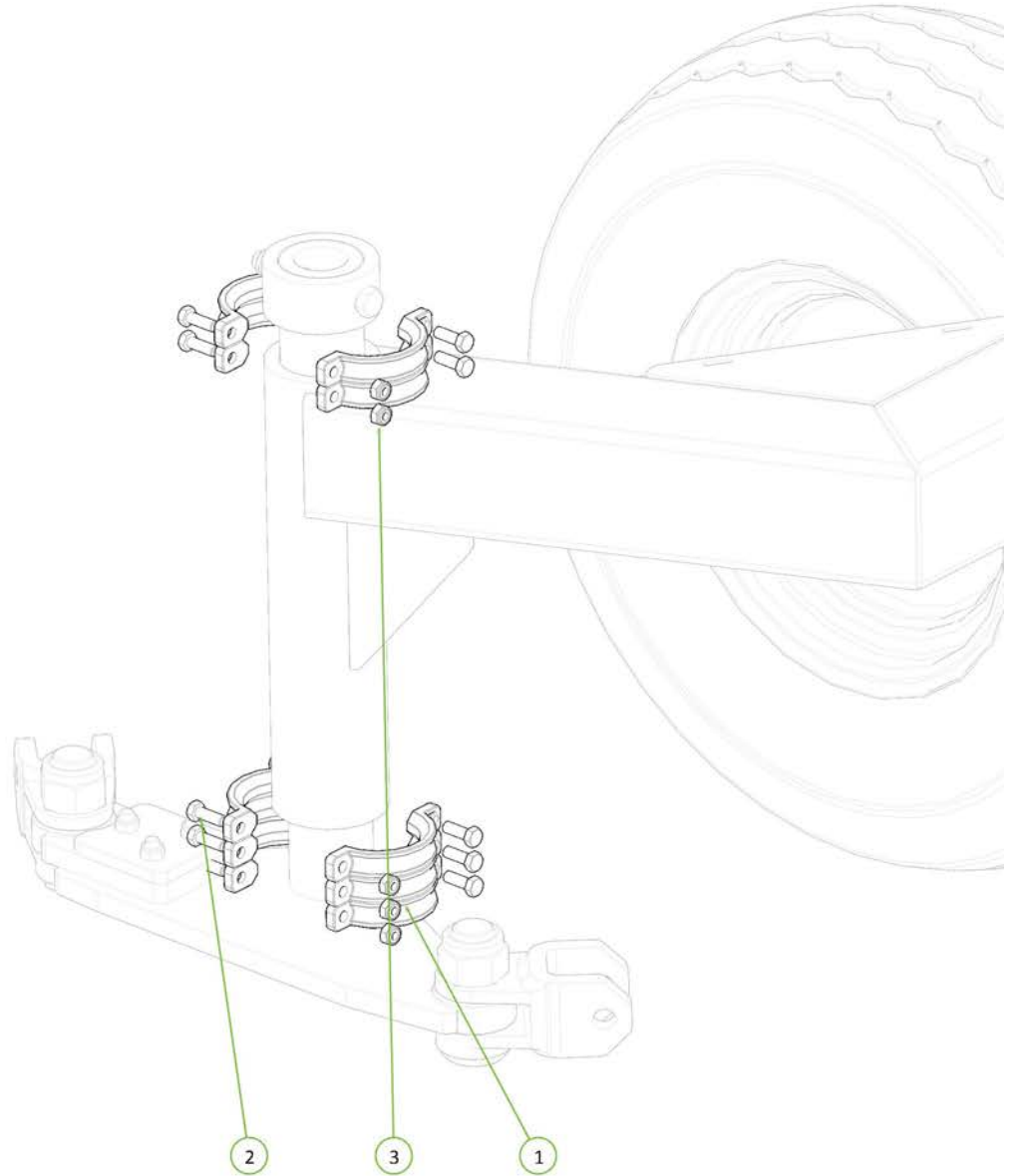

Item No.	Description	Qty	Number
1	M16 x 60 grade 8.8 zp Bolt	2	0211-1660
2	Washer Flat M16	2	0231-F16
3	Nyloc Nut M16	2	0221-NYL16
4	Rubber Wing Folding Buffer	2	1201-12

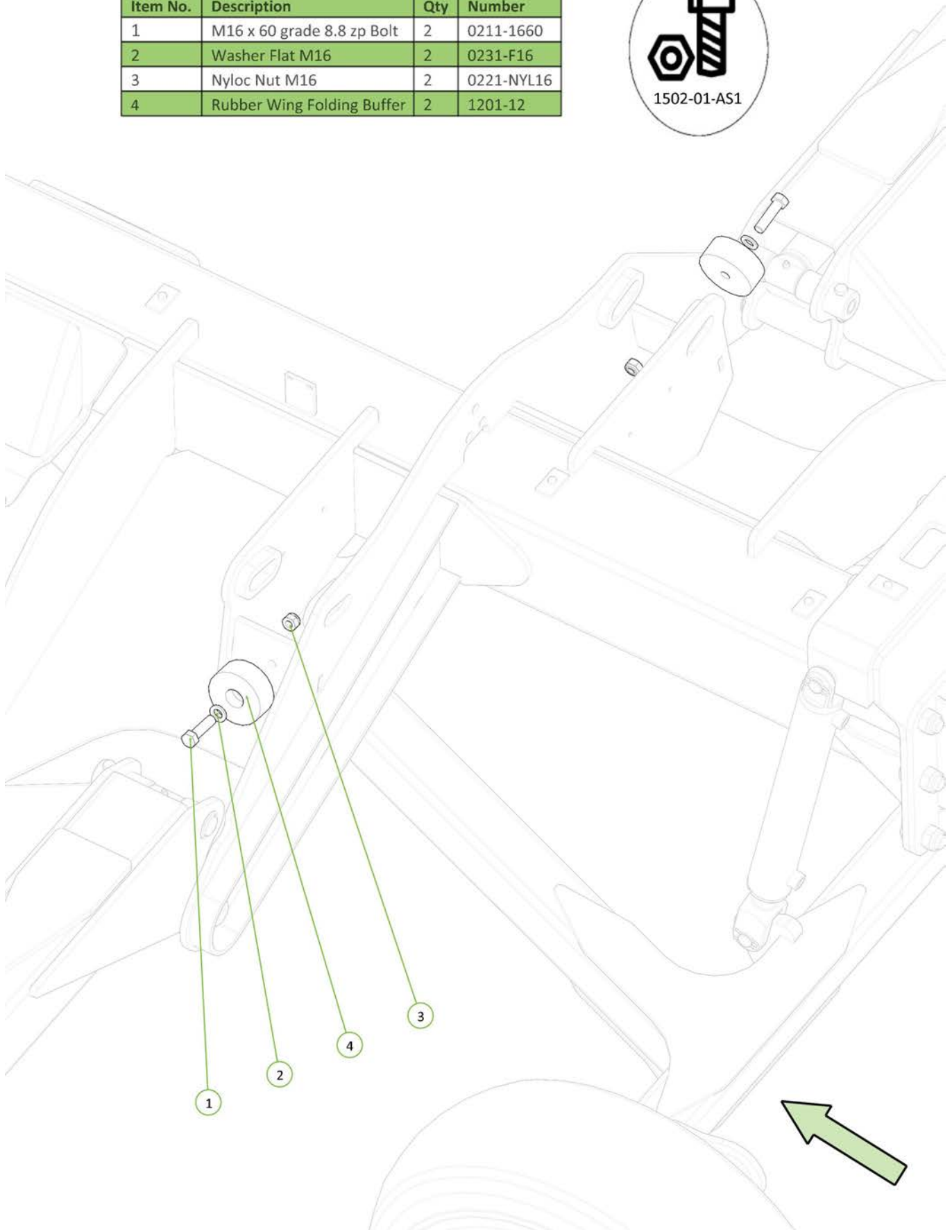

Item No.	Description	Qty	Number
1	Chain Mount Plate	2	1510-20
2	Nyloc Nut M12	2	0221-NYL12
3	M12 x 65 grade 8.8 ZP Bolt	2	0211-1265
4	Washer High Tensile 1 3/8"	2	0232-HT13-8
5	Cotter Pin M13 X 63mm	2	0261-PINC1363
6	Short Pivot Pin	2	1501-35330

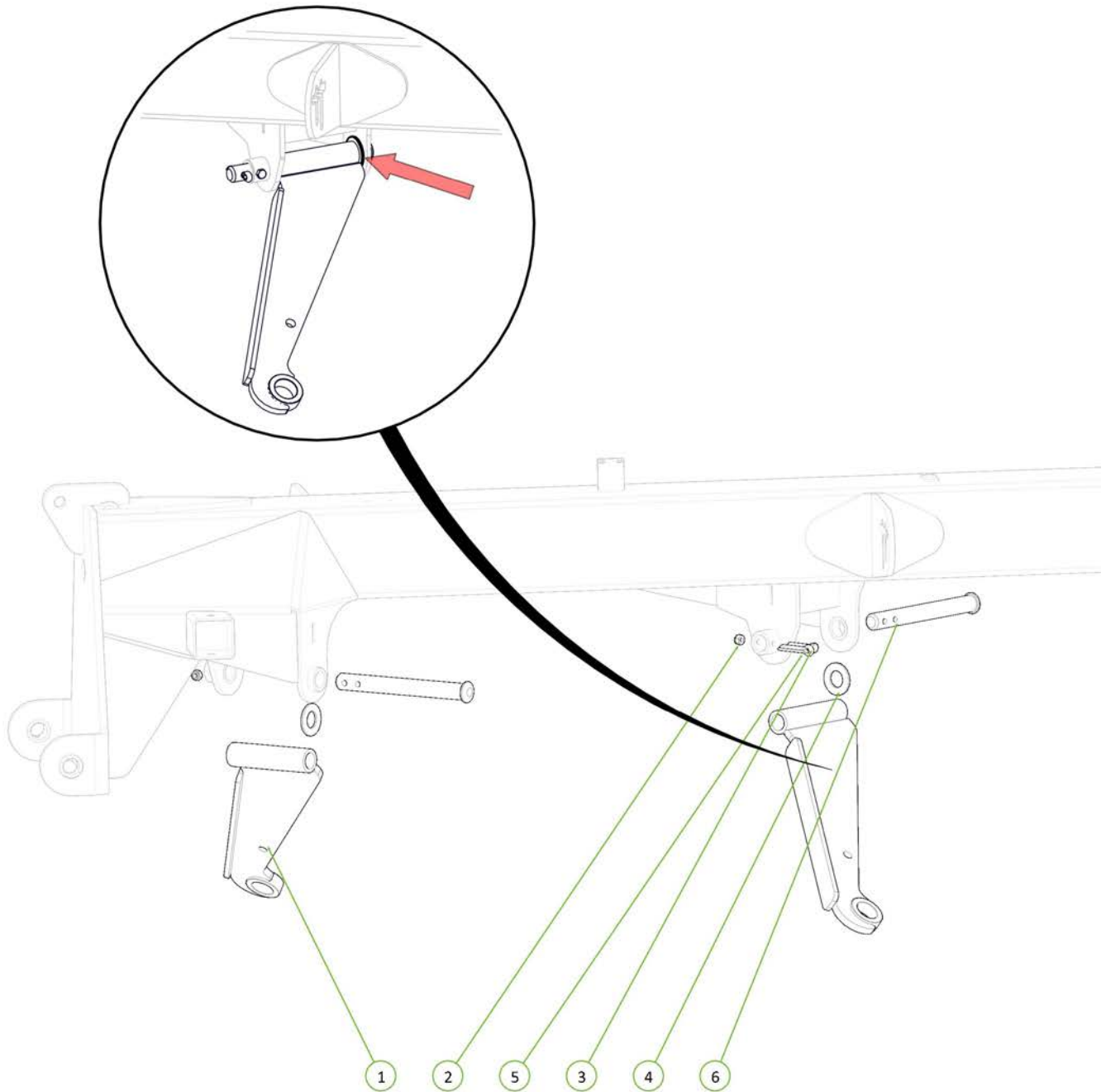

Item No.	Description	Qty	Number
1	Height Adjusting Chain Assembly 13 Link	1	0801-20MCA
2	Nyloc Nut M36	1	0221-NYL36
3	Wear Bush	1	1501-365033-SS
4	M36 x 105 grade 8.8 ZP Bolt	1	0211-36105
5	Height Adjustor Retaining Clip	1	0801-KE014
6	Forged Clevis 21mm Bolt Hole	1	0801-FC21

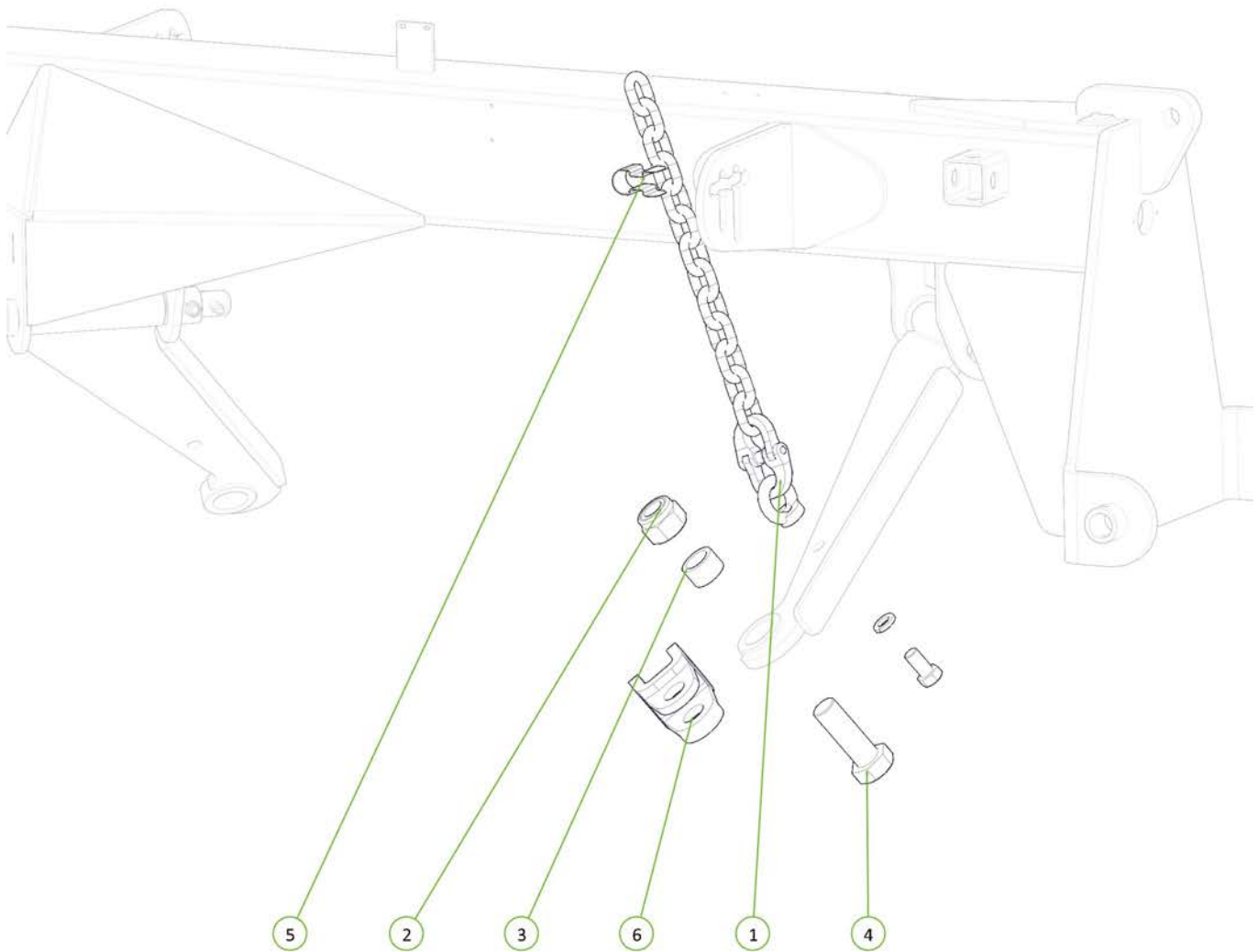
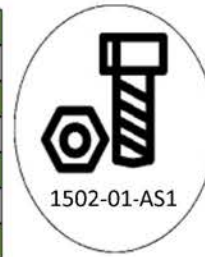

Item No.	Description	Qty	Number
1	Height Adjusting Chain Assembly 13 Link	1	0801-20MCA
2	Nyloc Nut M36	1	0221-NYL36
3	Forged Clevis 21mm Bolt Hole	1	0801-FC21
4	Wear Bush	1	1501-365033-SS
5	M36 x 105 grade 8.8 ZP Bolt	1	0211-36105
6	Height Adjustor Retaining Clip	1	0801-KE014

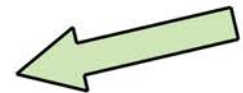
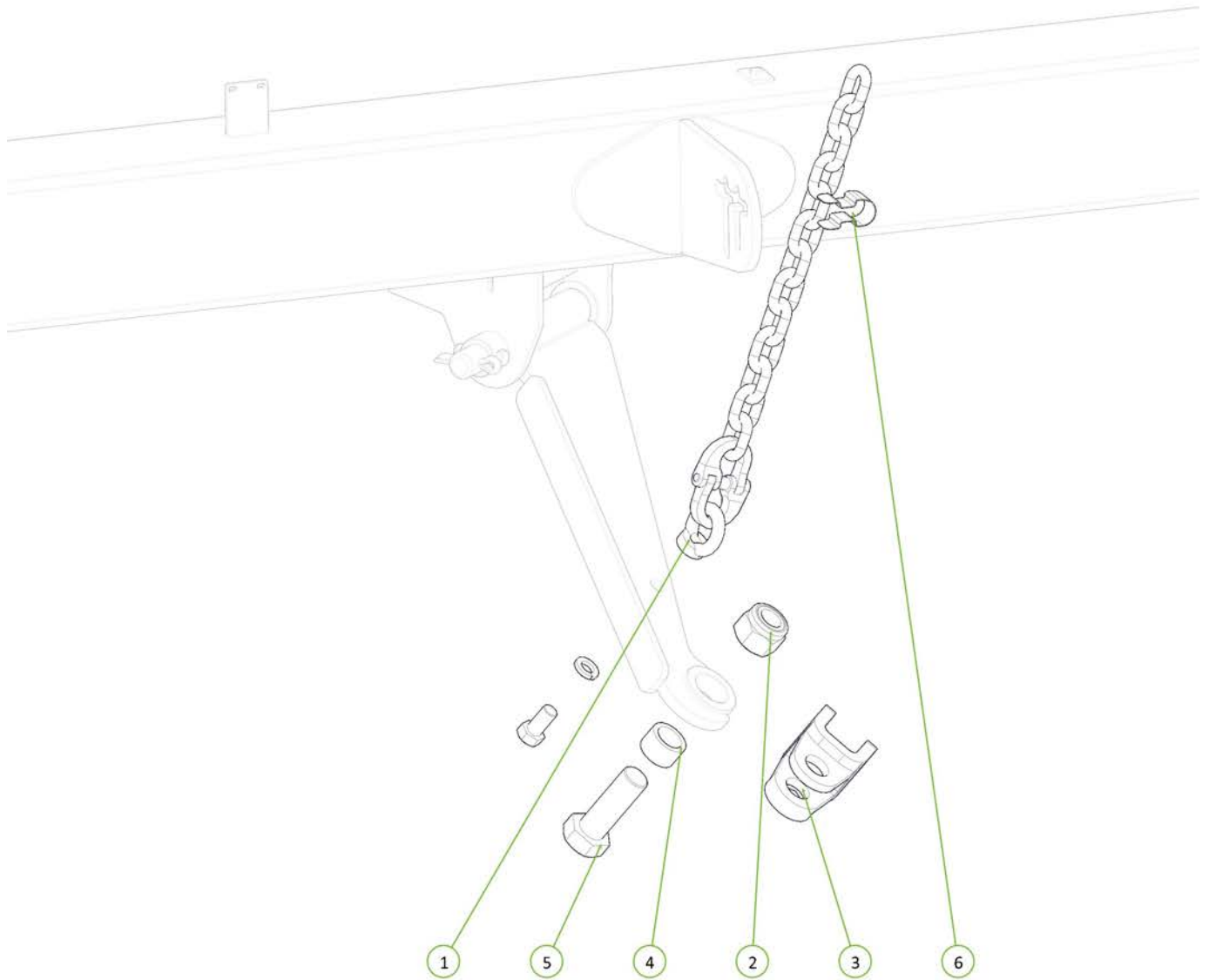

Item No.	Description	Qty	Number
1	M12 x 65 grade 8.8 ZP Bolt	2	0211-1265
2	Nyloc Nut M12	2	0221-NYL12
3	Washer High Tensile 1 3/8"	2	0232-HT13-8
4	Cotter Pin M13 X 63mm	2	0261-PINC1363
5	Short Pivot Pin	2	1501-35330
6	Chain Mount Plate	2	1510-20

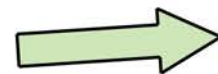
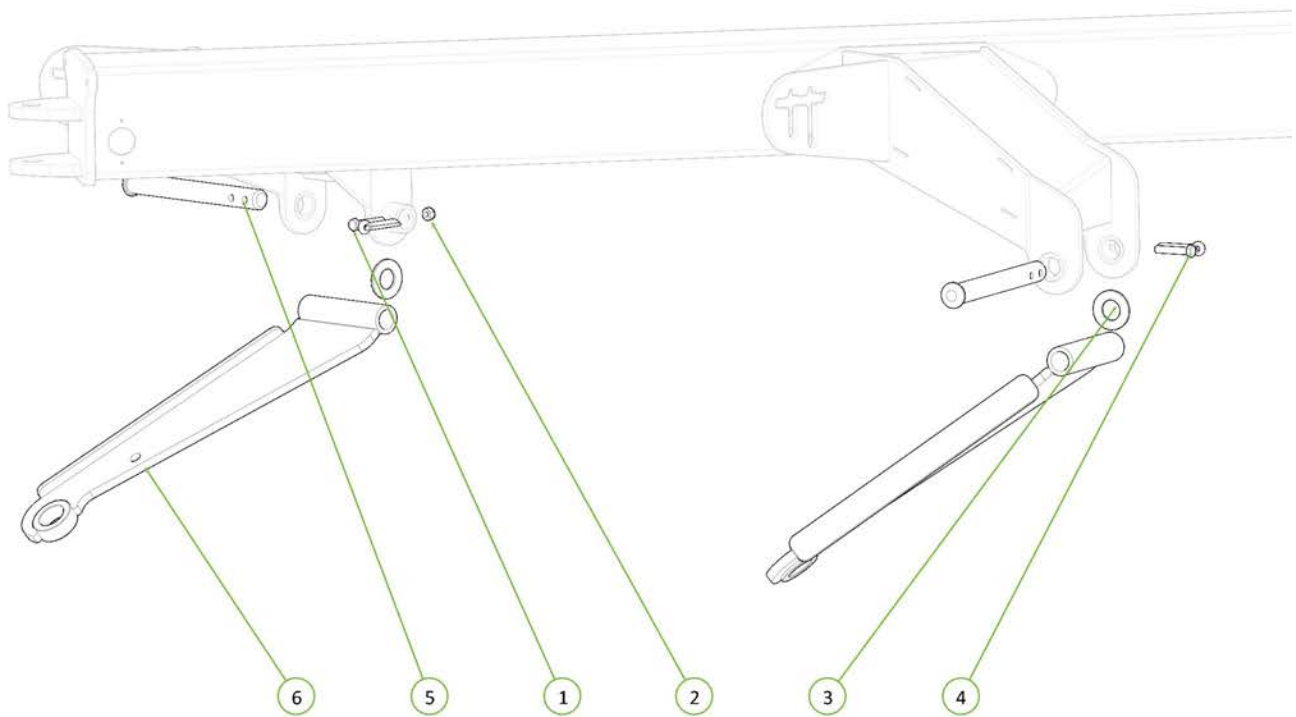

Item No.	Description	Qty	Number
1	M36 x 105 grade 8.8 ZP Bolt	1	0211-36105
2	Wear Bush	1	1501-365033-SS
3	Nyloc Nut M36	1	0221-NYL36
4	Height Adjusting Chain Assembly 13 Link	1	0801-20MCA
5	Forged Clevis 21mm Bolt Hole	1	0801-FC21
6	Height Adjustor Retaining Clip	1	0801-KE014

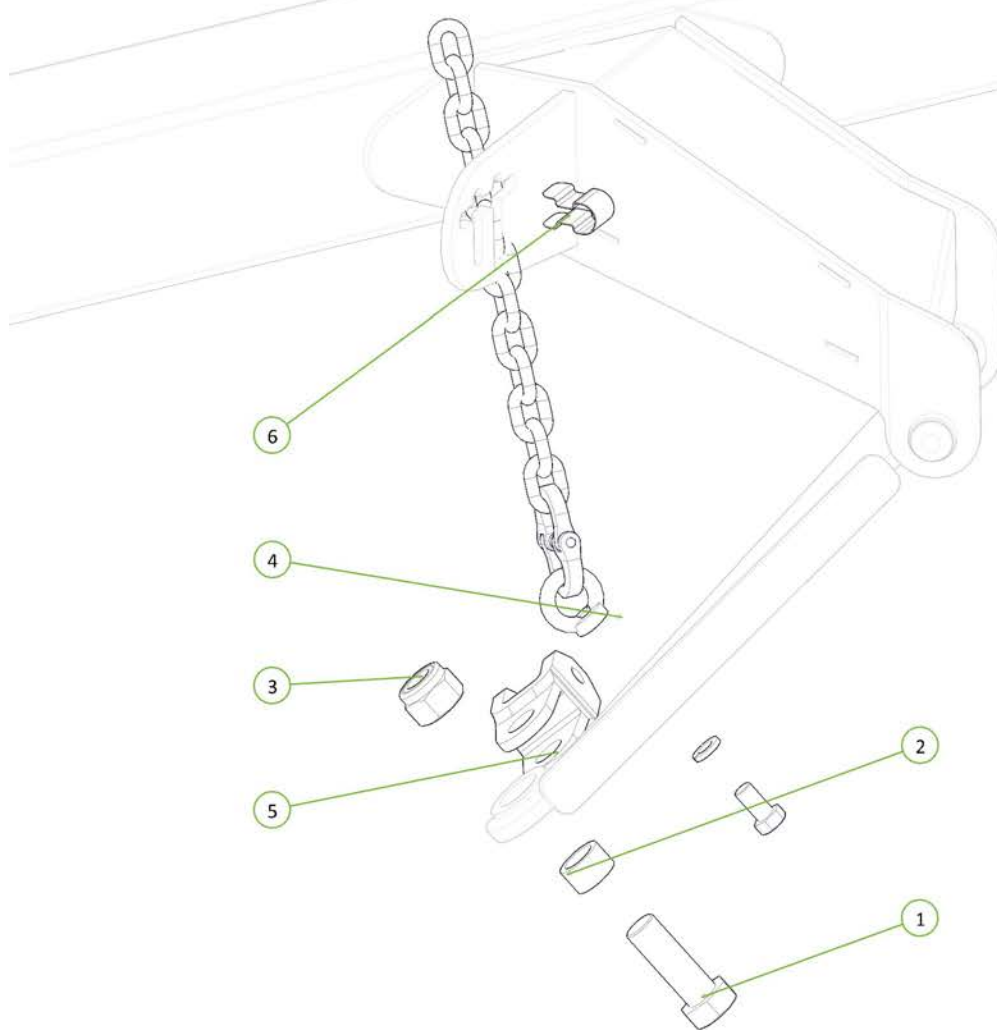

Item No.	Description	Qty	Number
1	Height Adjusting Chain Assembly 13 Link	1	0801-20MCA
2	M36 x 105 grade 8.8 ZP Bolt	1	0211-36105
3	Nyloc Nut M36	1	0221-NYL36
4	Forged Clevis 21mm Bolt Hole	1	0801-FC21
5	Height Adjustor Retaining Clip	1	0801-KE014
6	Wear Bush	1	1501-365033-SS

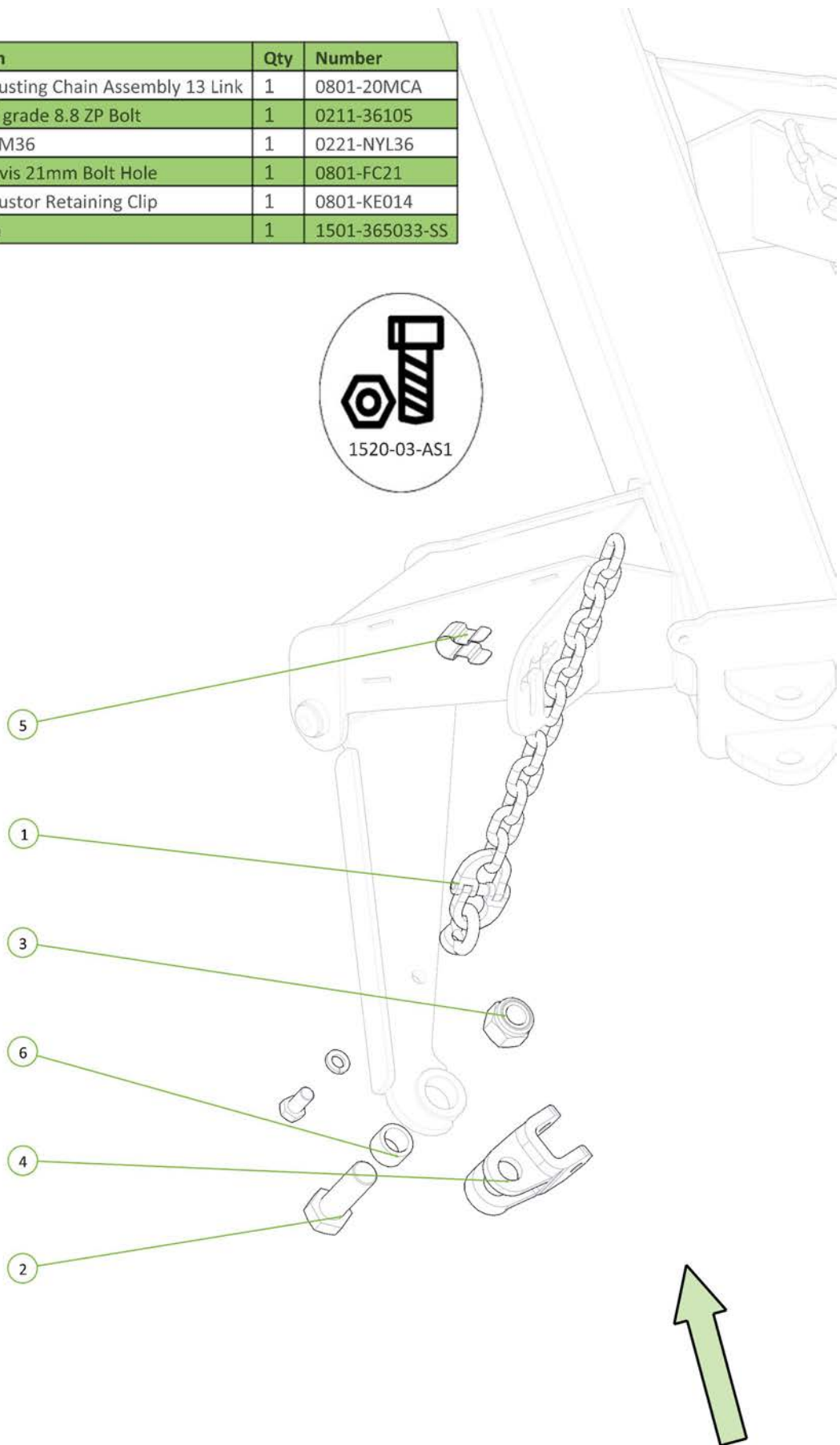

Item No.	Description	Qty	Number
1	6m Drawbar Frame	1	1520-08
2	35 ID x 50mm DU Bush	2	0113-MB 3550DU
3	Long Pivot Pin	1	1501-35615
4	Nyloc Nut M12	1	0221-NYL12
5	M12 x 65 grade 8.8 ZP Bolt	1	0211-1265
6	Cotter Pin M13 X 63mm	1	0261-PINC1363

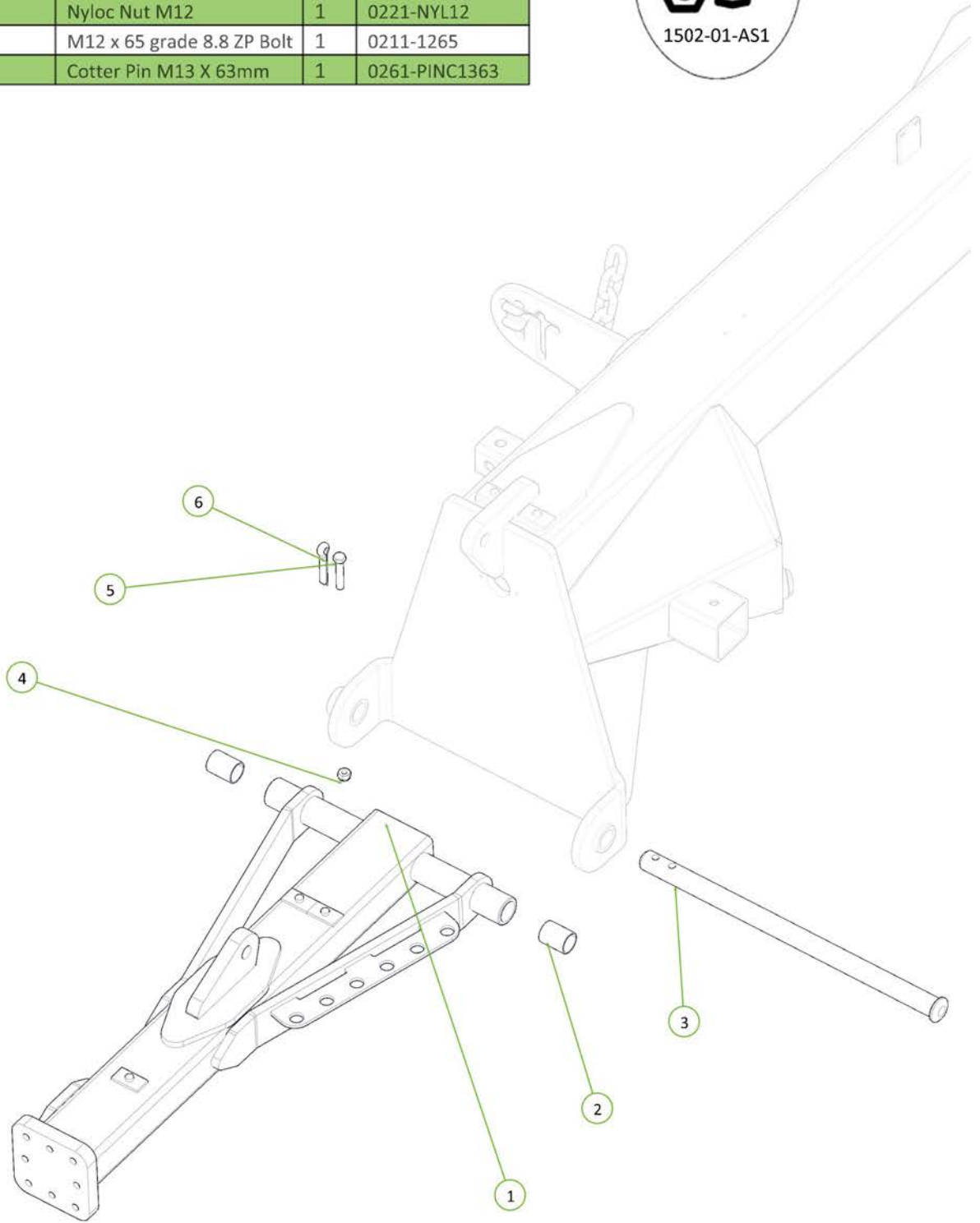

Item No.	Description	Qty	Number
1	M16 x 50 grade 8.8 zp Bolt	8	0211-1650
2	M16 Spring Washer	8	0231-S16
3	Washer Flat M16	6	0231-F16
4	50mm Flanged Drawbar Eye	1	1501-RCBD50MM
5	Safety Chain Assembly	1	0810-16

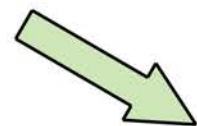
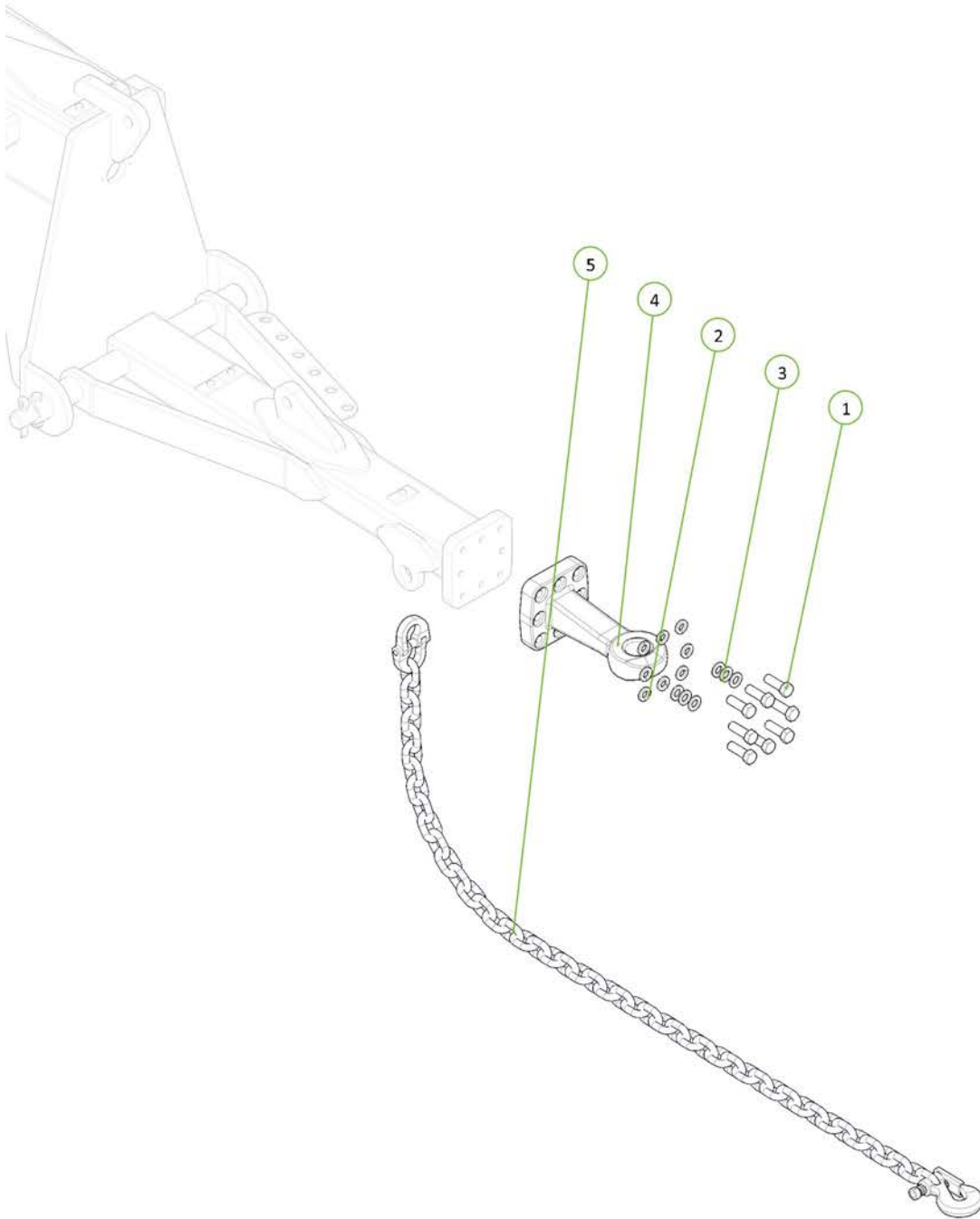

Item No.	Description	Qty	Number
1	M5 x 0.8 x 15mm Grade 4.6 ZP Bolt	2	0211-515
2	M5 Spring Washer	2	0231-55
3	Wiring Capping Plate	1	1500-122

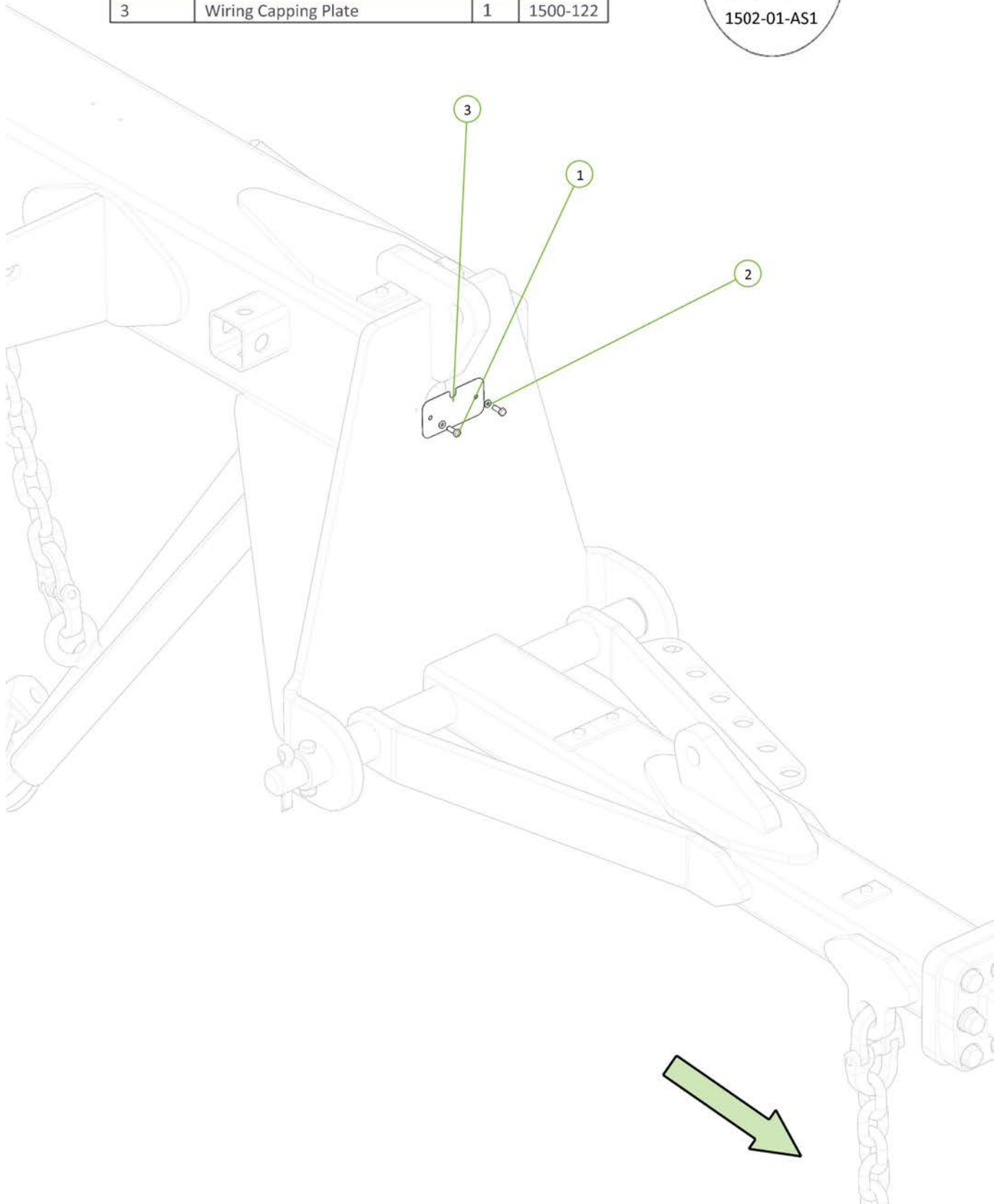

Item No.	Description	Qty	Number
1	Heavy Duty Ratchet Ram	1	0801-19RAJ013

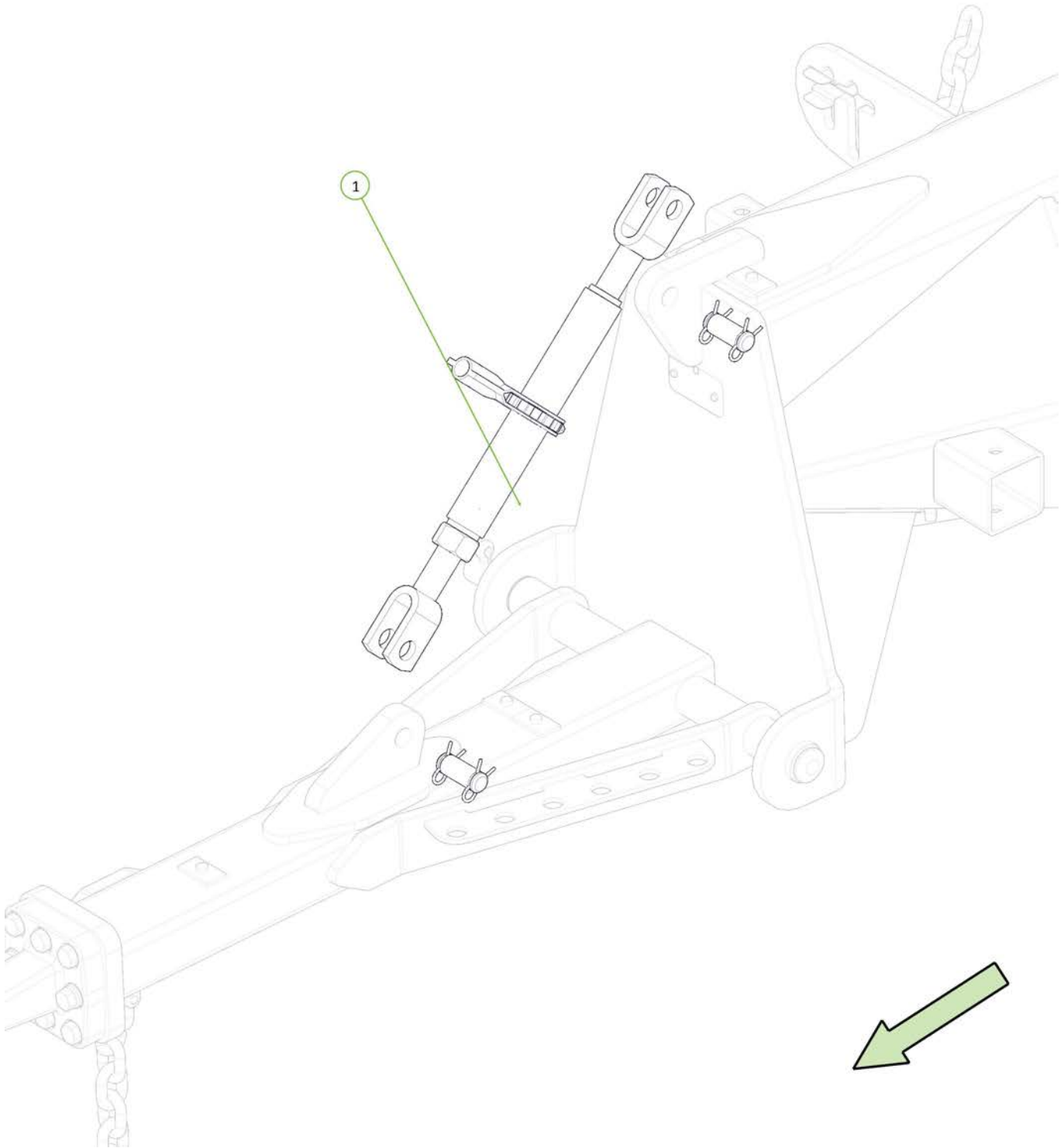

Item No.	Description	Qty	Number
1	Spacer bush	2	1501-325120
2	Cylinder Pin 1 1/4" x 245mm	1	1501-44102956
3	Washer Flat M30	2	0231-F30
4	S Locking Pin Clip 5mm	2	0801-KE012
5	3.5" Bore x 32" Stroke 1.75" Rod Cylinder	1	0313-3532ST

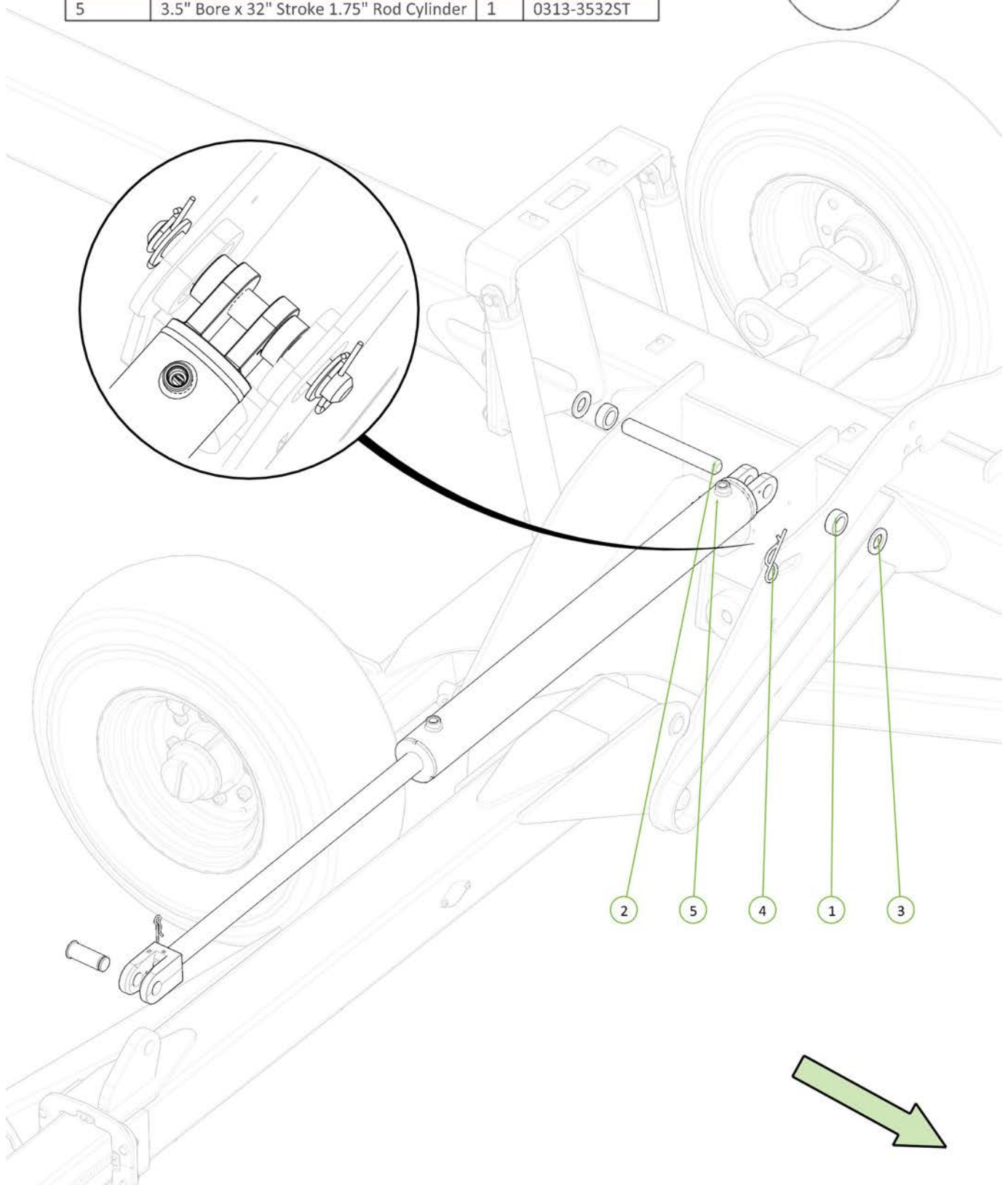

Item No.	Description	Qty	Number
1	Spacer bush	2	1501-325120
2	3.5" Bore x 32" Stroke 1.75" Rod Cylinder	1	0313-3532ST
3	S Locking Pin Clip 5mm	2	0801-KE012
4	Washer Flat M30	2	0231-F30
5	Cylinder Pin 1 1/4" x 245mm	1	1501-44102956

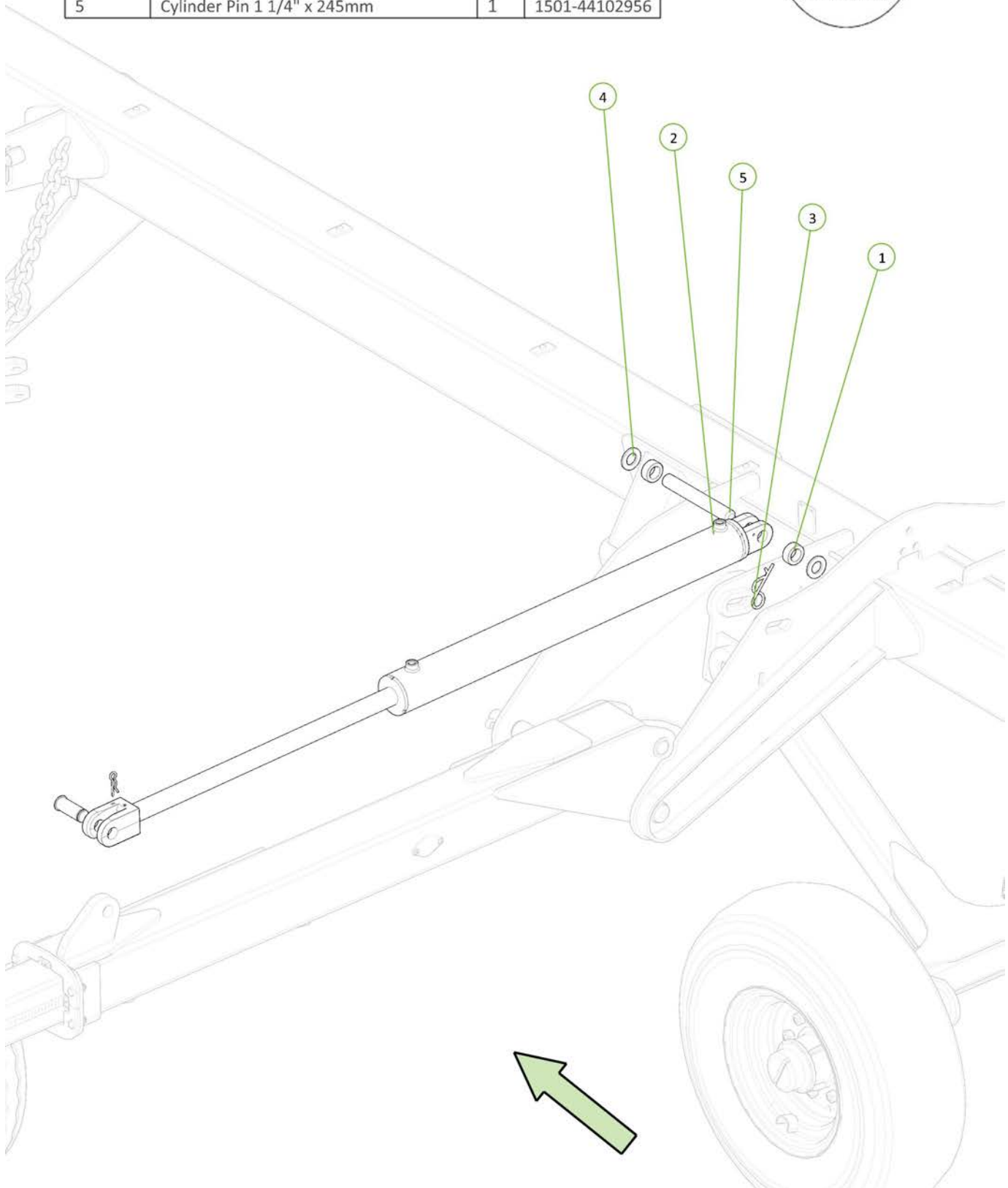

Item No.	Description	Qty	Number
1	M6 x 20mm Trilobe Screw	3	0211-M620MZPHTF
2	OPERATOR MANUAL CANNISTER	1	0801-OMC
3	M20 x 110 grade 10.9 ZP Short Thread Bolt	1	0211-20110 ST
4	Nyloc Nut M20	1	0221-NYL20
5	20mm Bolt Swivel Unit	1	0802-PCHB55

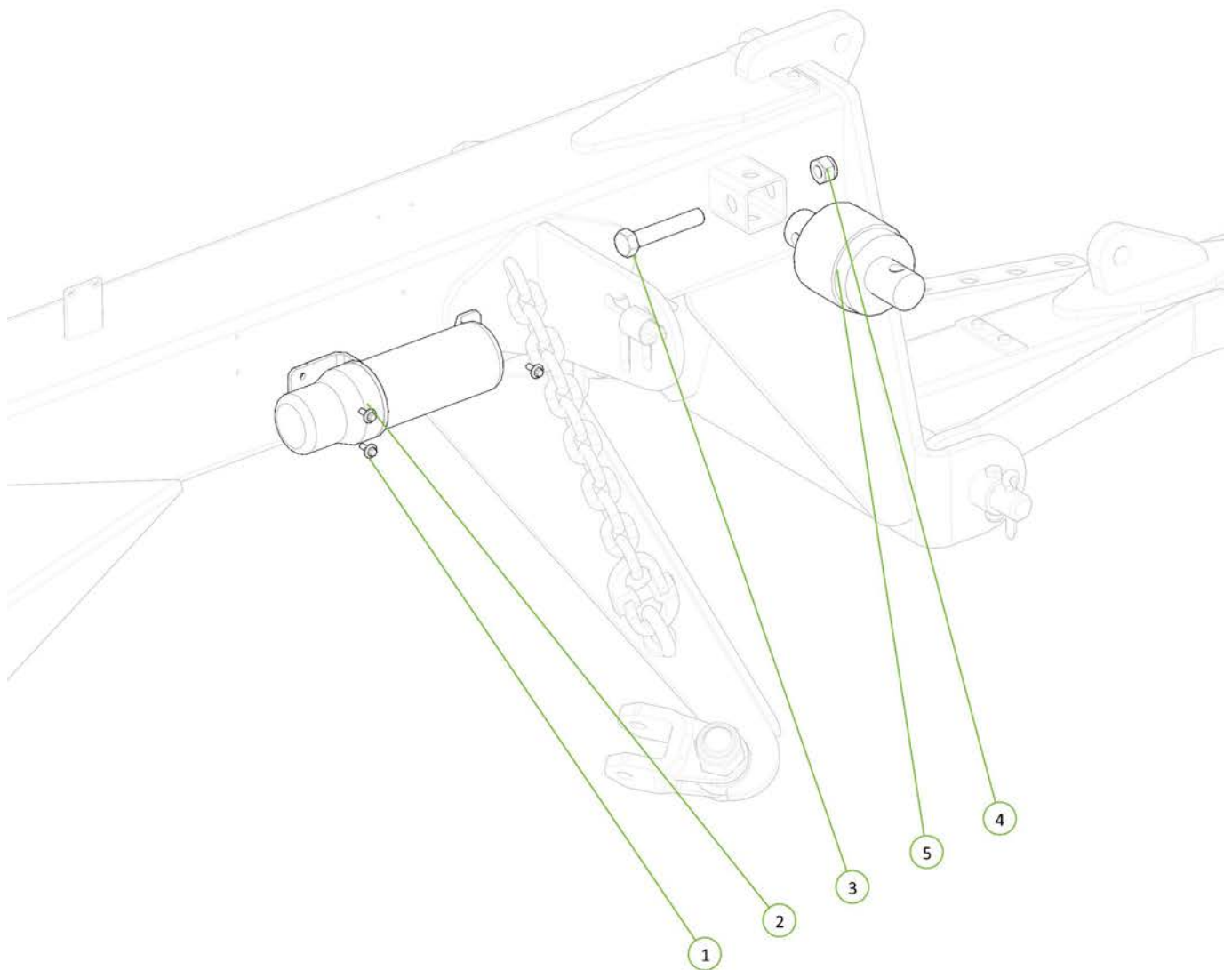

Item No.	Description	Qty	Number
1	20mm Bolt Swivel Unit	2	0802-PCHB55
2	M20 x 110 grade 10.9 ZP Short Thread Bolt	4	0211-20110 ST
3	Tie Plate Disc 20mm	2	0802-DCTP-20
4	Nyloc Nut M20	4	0221-NYL

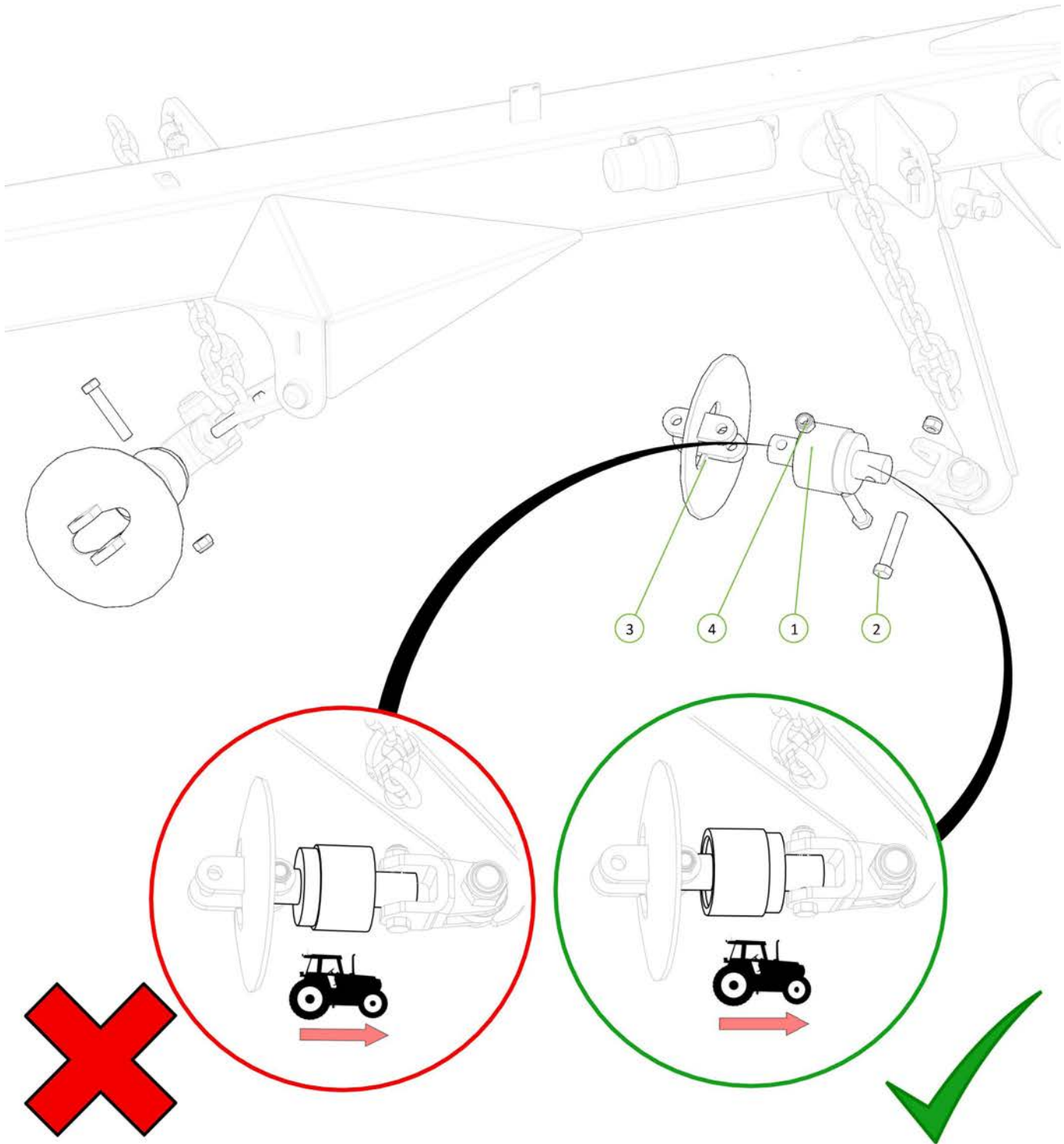
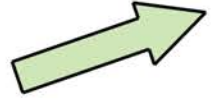

Item No.	Description	Qty	Number
1	20mm Bolt Swivel Unit	2	0802-PCHB55
2	Tie Plate Disc 20mm	2	0802-DCTP-20
3	M20 x 110 grade 10.9 ZP Short Thread Bolt	4	0211-20110 ST
4	Nyloc Nut M20	4	0221-NYL20

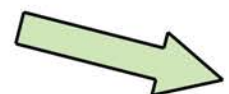
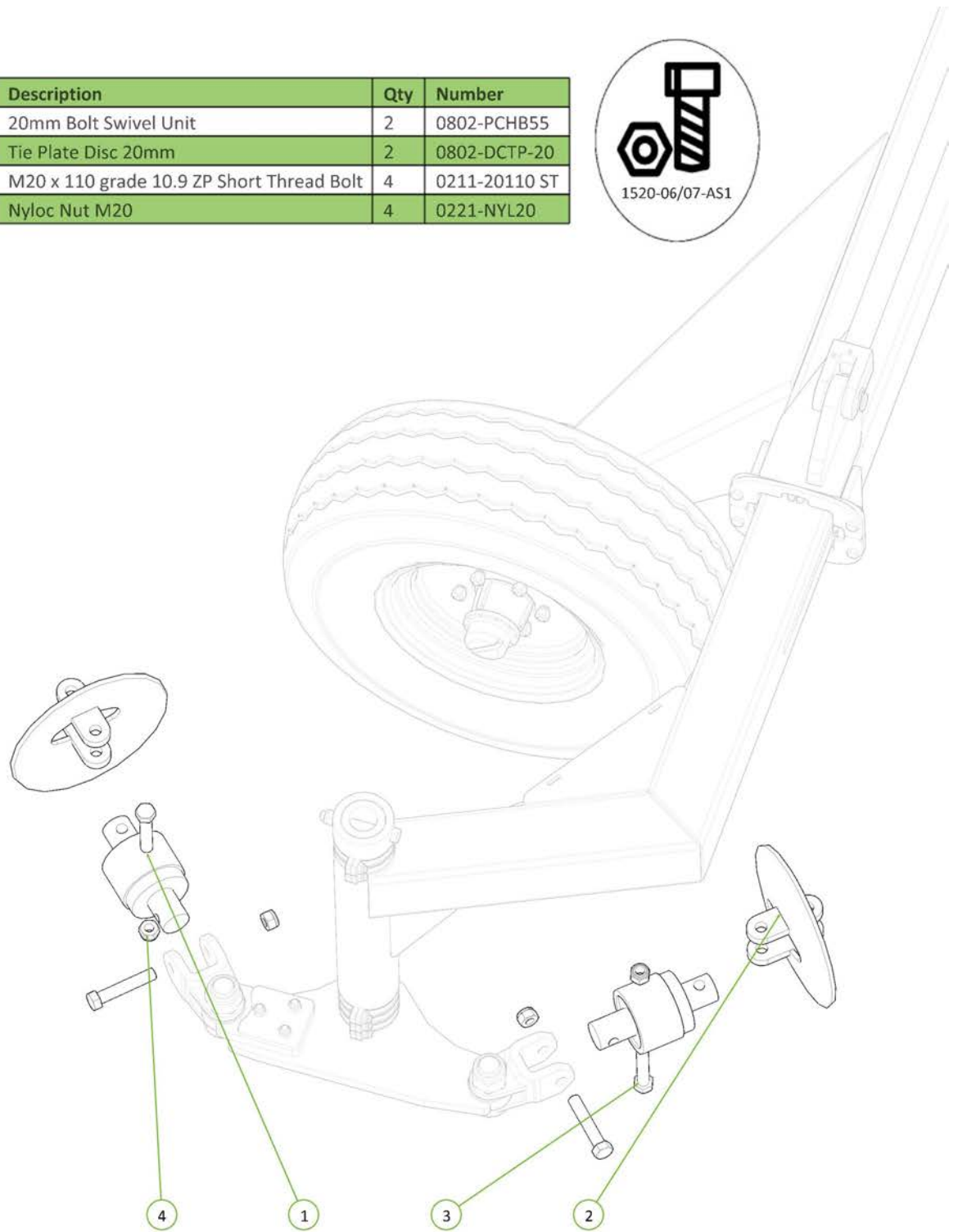

Item No.	Description	Qty	Number
1	20mm Swivel Bearing unit	2	0802-PCHB55
2	M20 x 110 grade 10.9 ZP Short Thread Bolt	4	0211-20110 ST
3	Nyloc Nut M20	4	0221-NYL20
4	Tie Plate Disc 20mm	2	0802-DCTP-20

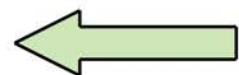
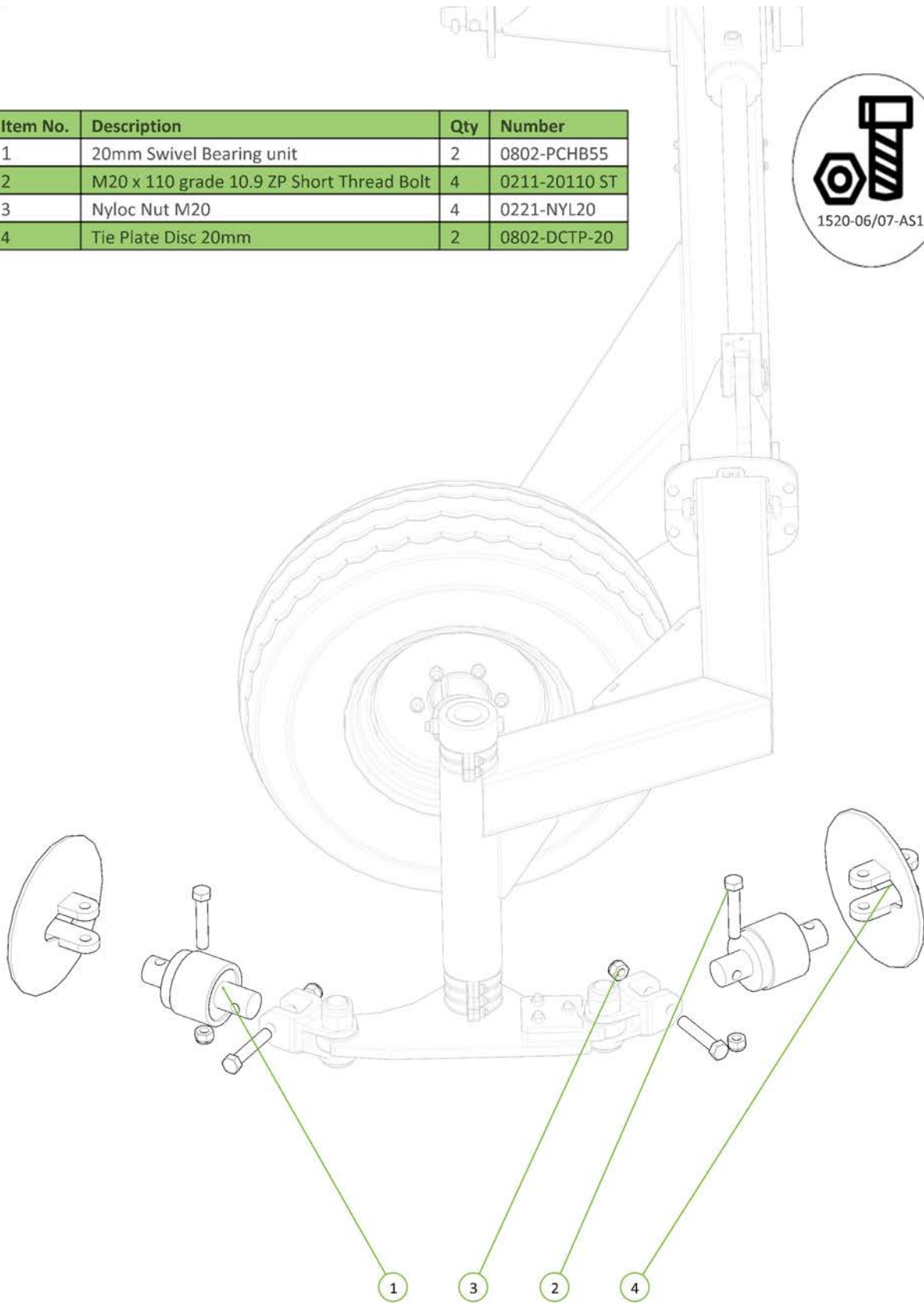

Item No.	Description	Qty	Number
1	Tie Plate Disc 20mm	2	0802-DCTP-20
3	20mm Bolt Swivel Unit	2	0802-PCHB55
4	Nyloc Nut M20	4	0221-NYL20
5	M20 x 110 grade 10.9 ZP Short Thread Bolt	4	0211-20110 ST

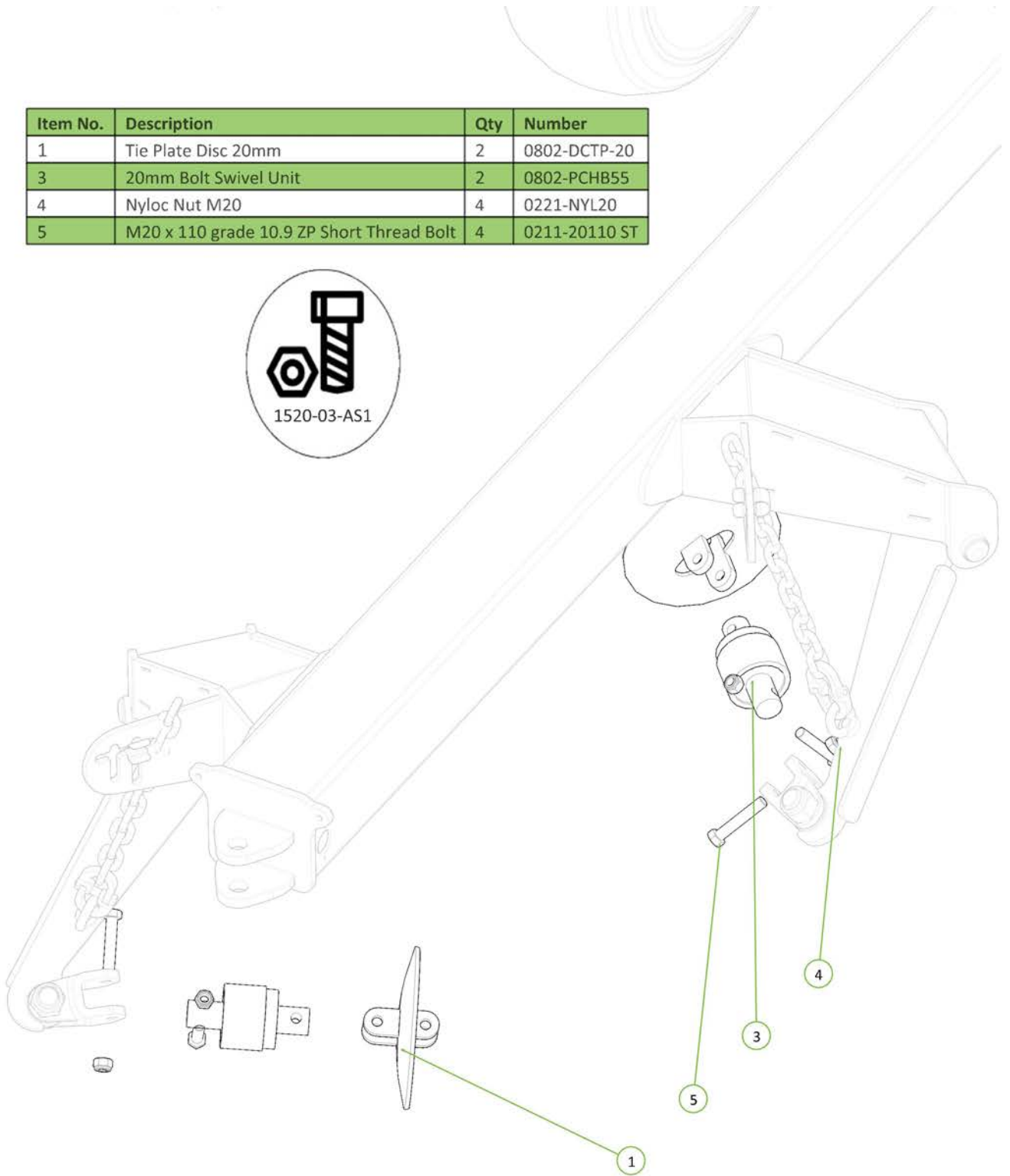

Item No.	Description	Qty	Number
1	Jack Pin	1	0801-B3077
2	Jack Assembly	1	0801-Jack3T

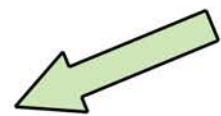
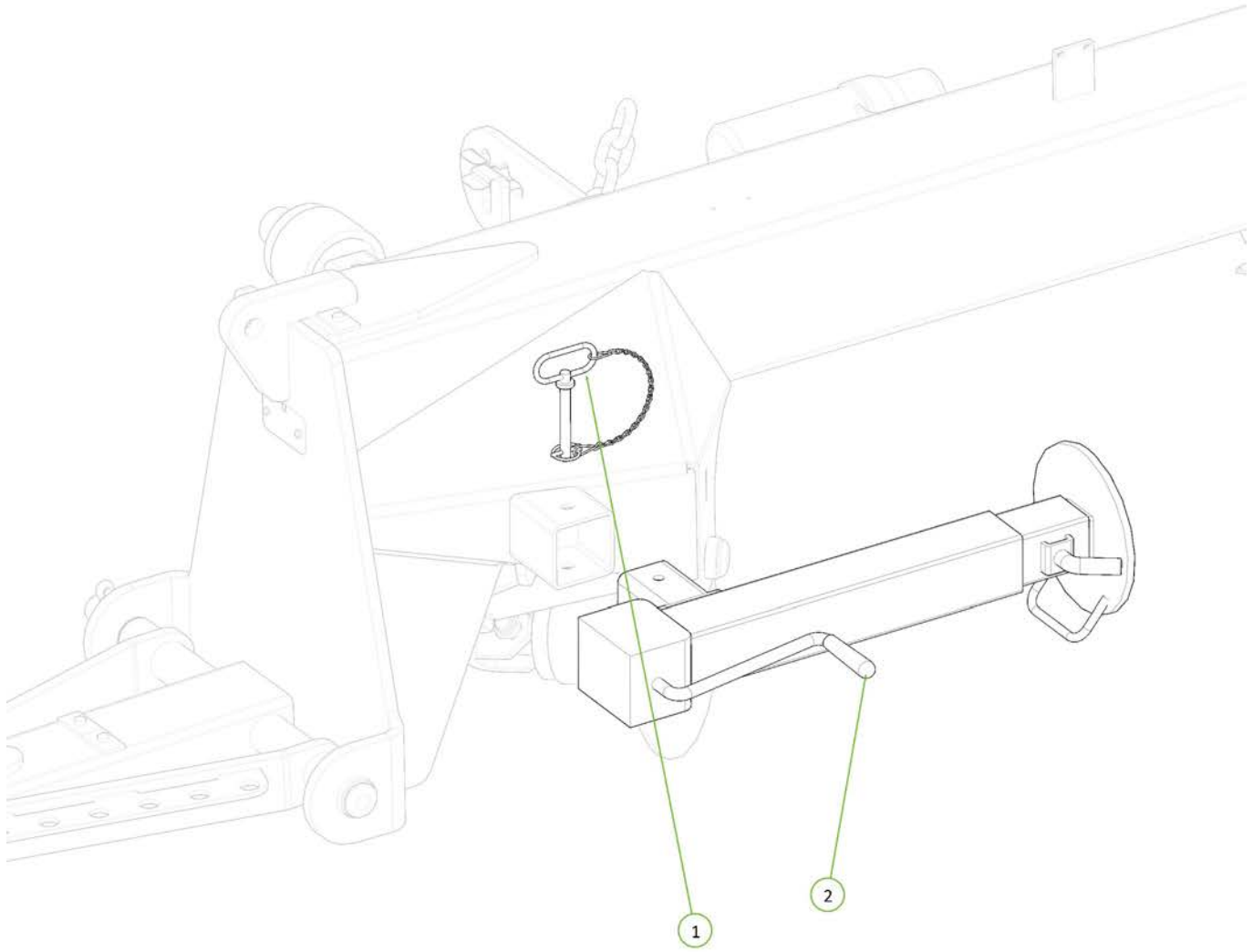

Item No.	Description	Qty	Number
1	M12 x 40 grade 8.8 ZP Bolt	6	0211-1240
2	Nyloc Nut M12	14	0221-NYL12
3	Washer Flat M12	8	0231-F12
4	U-Bolt M12 x 225 Deep x 202 Wide	4	0271-12225202
5	Chain Carrier Web LH Side	2	1500-086
6	Chain Carrier Web RH Side	2	1500-085
7	Chain Catch 6M	2	1500-084

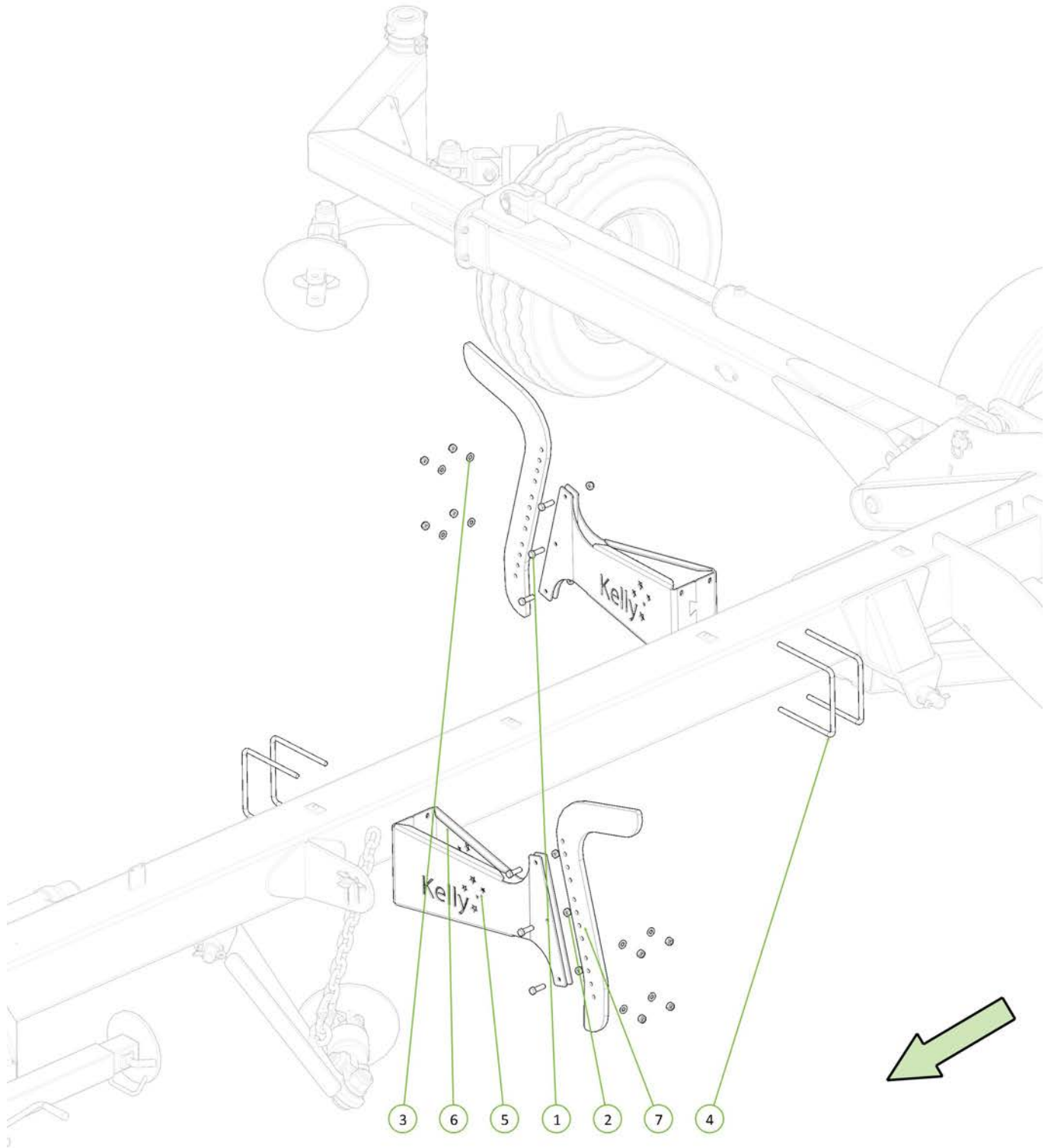

Item No.	Description	Qty	Number
1	U-Bolt M12 x 225 Deep x 202 Wide	4	0271-12225202
2	Nyloc Nut M12	14	0221-NYL12
3	Washer Flat M12	8	0231-F12
4	M12 x 40 grade 8.8 ZP Bolt	6	0211-1240
5	Chain Catch 6M	2	1500-084
6	Chain Carrier Web RH Side	2	1500-085
7	Chain Carrier Web LH Side	2	1500-086

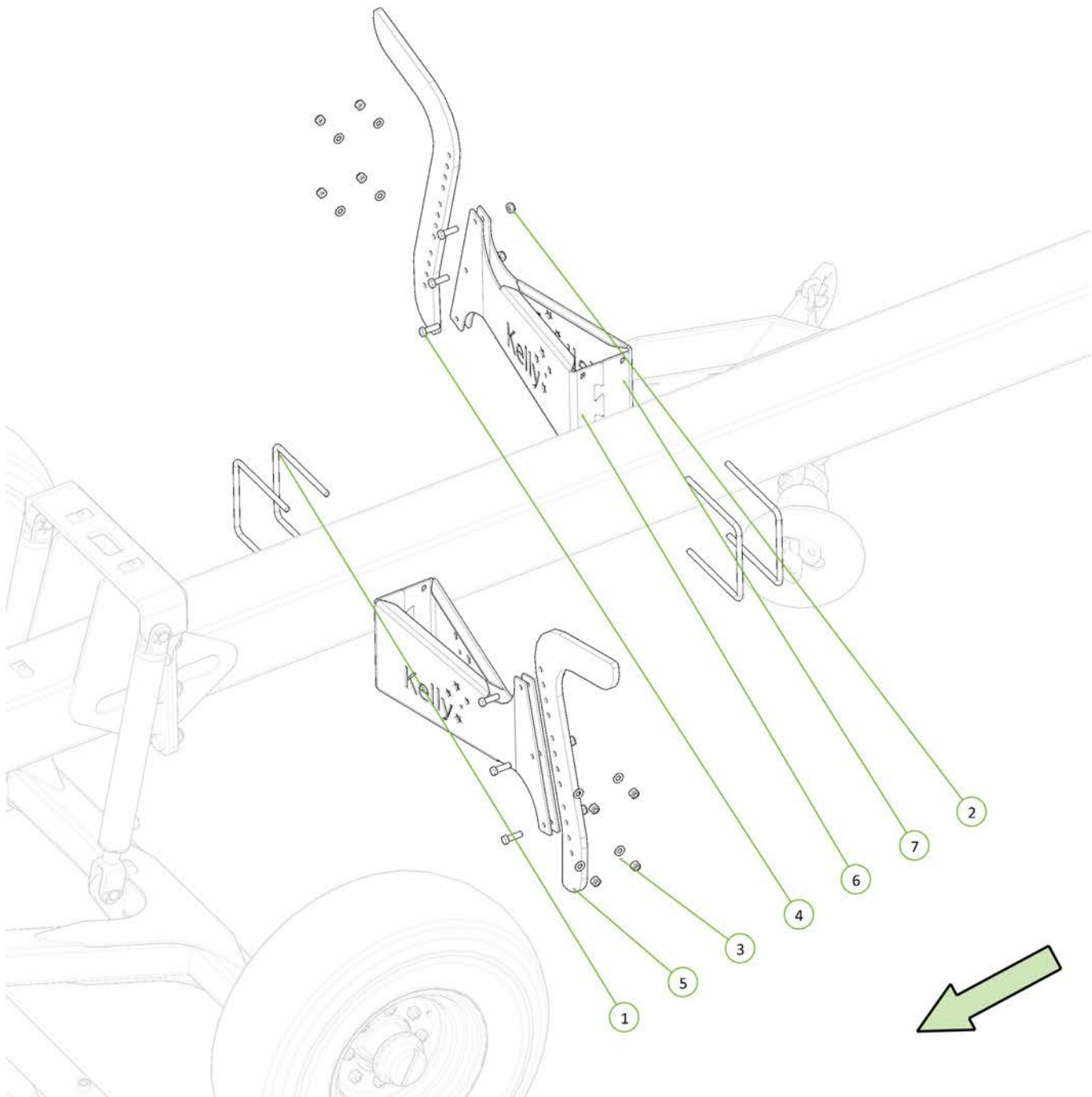

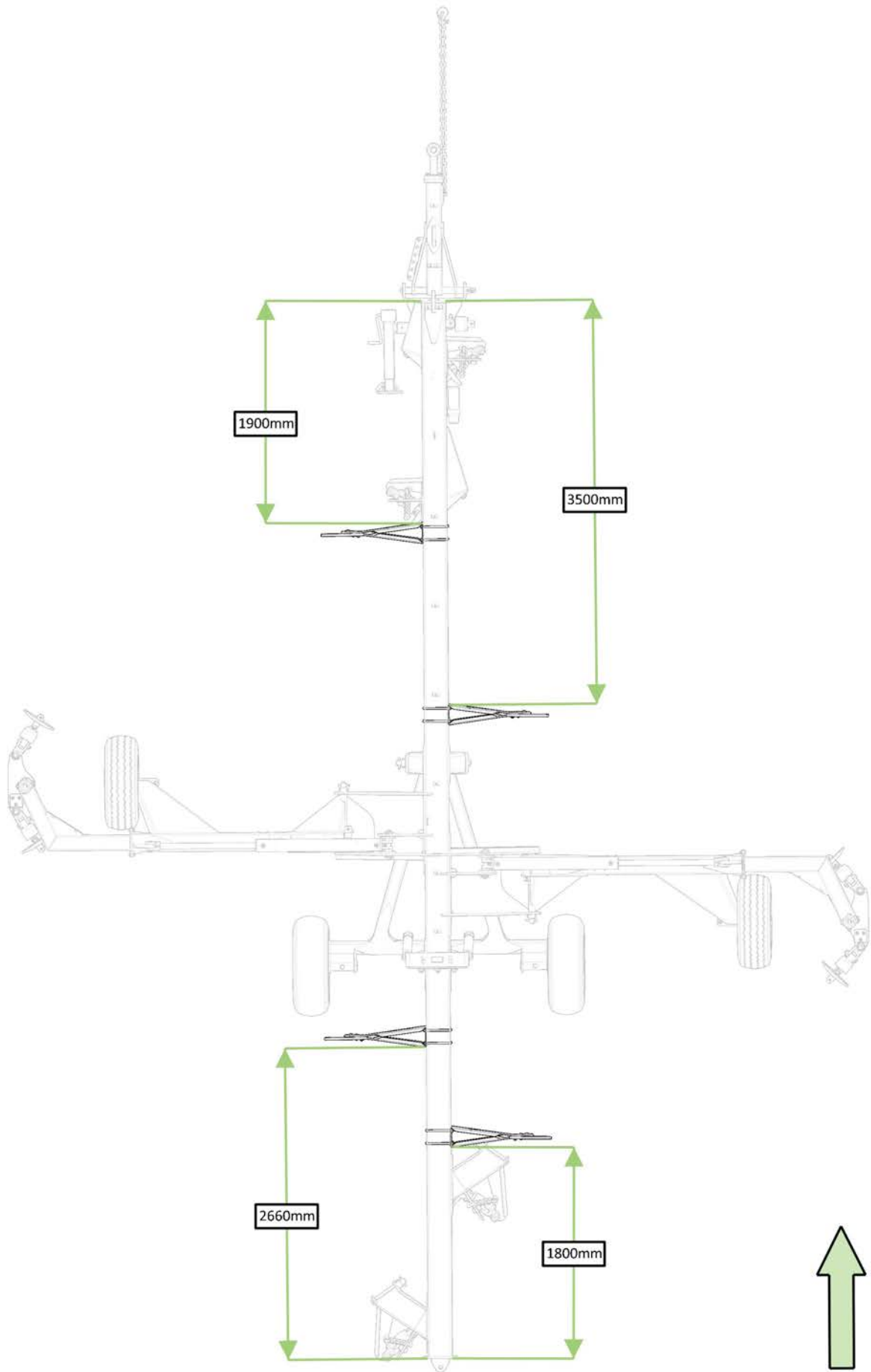

Item No.	Description	Qty	Number
1	M20 x 110 grade 10.9 ZP Short Thread Bolt	2	0211-20110 ST
2	Nyloc Nut M20	2	0221-NYL20
3	Disc Chain Spacer	2	0801-PCDCS55

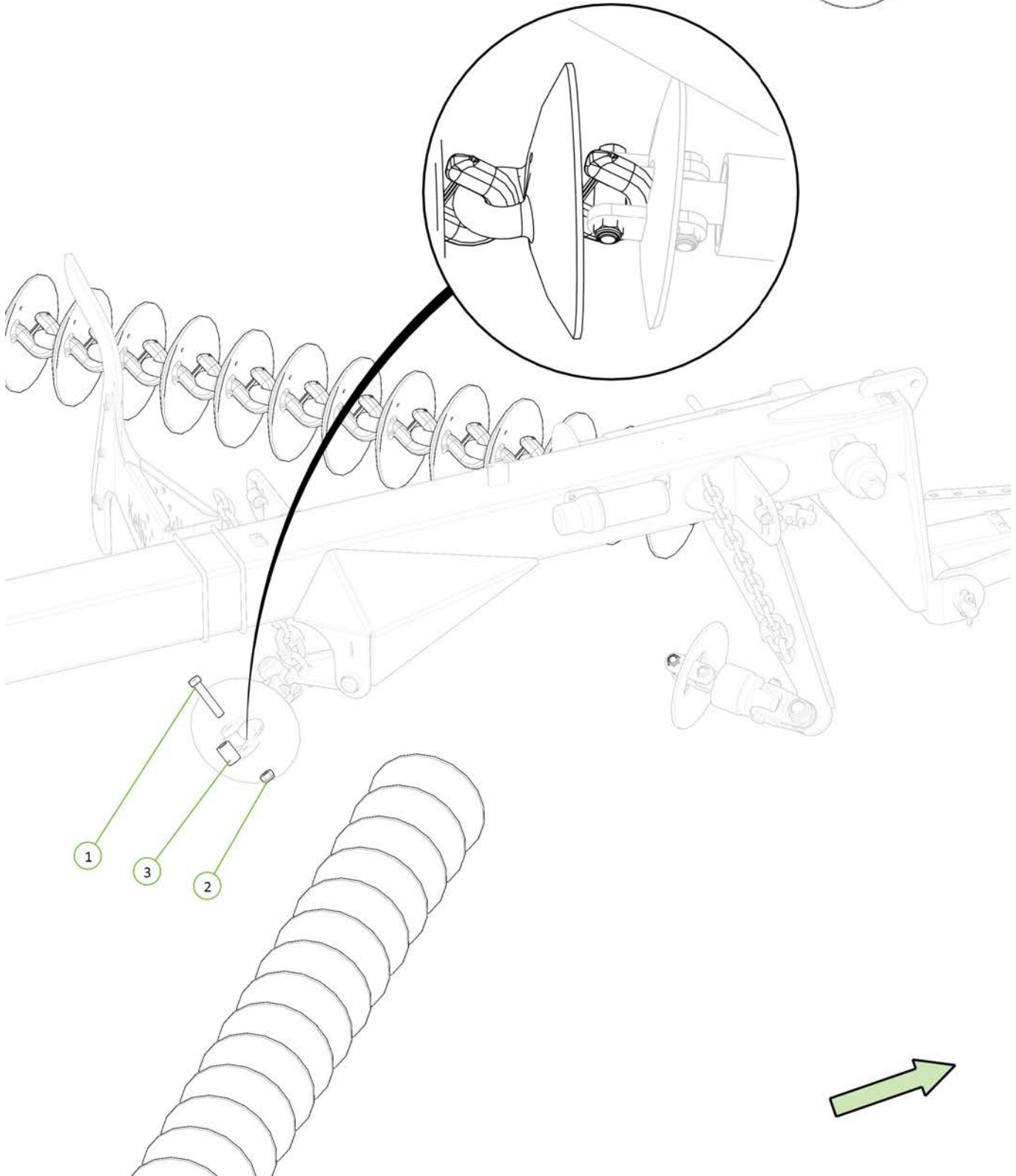

Item No.	Description	Qty	Number
1	M20 x 110 grade 10.9 ZP Short Thread Bolt	2	0211-20110 ST
2	Nyloc Nut M20	2	0221-NYL20
3	Disc Chain Spacer	2	0801-PCDCS55

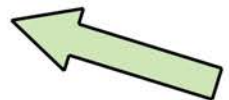
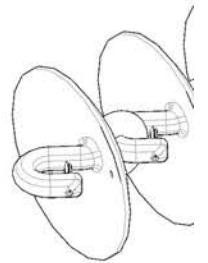
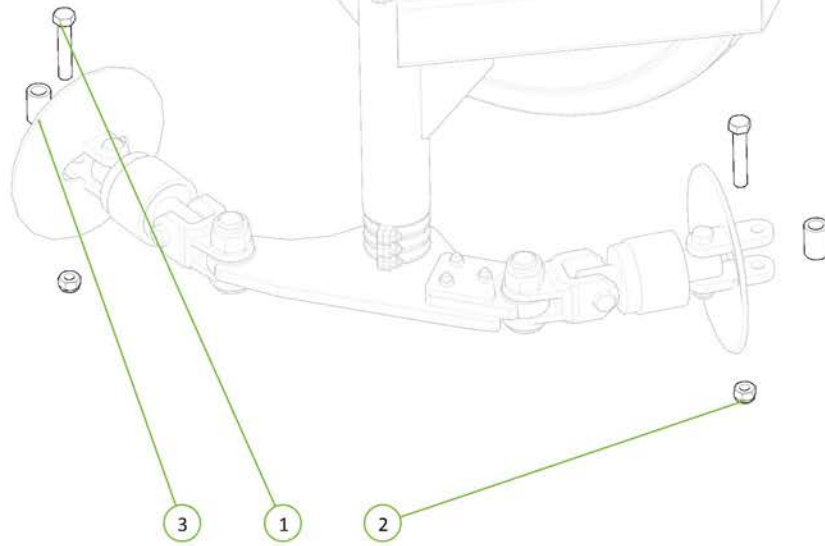
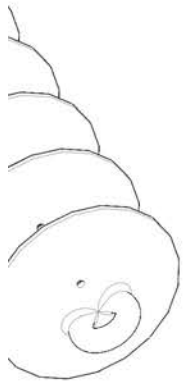

Item No.	Description	Qty	Number
1	M20 x 110 grade 10.9 ZP Short Thread Bolt	2	0211-20110 ST
2	Nyloc Nut M20	2	0221-NYL20
3	Disc Chain Spacer	2	0801-PCDCS55

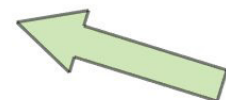
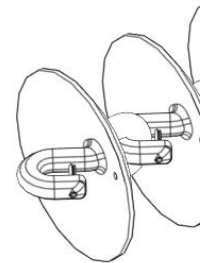
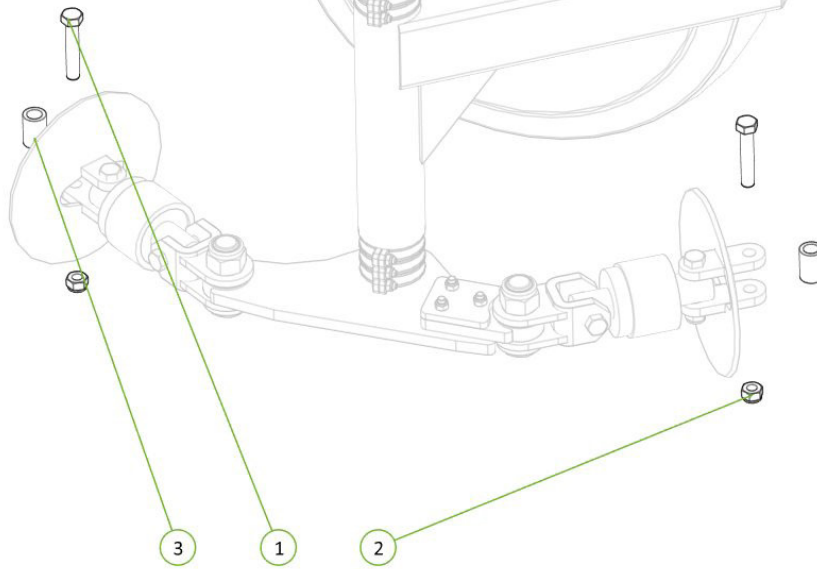
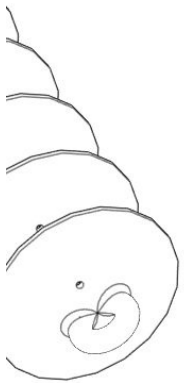

Item No.	Description	Qty	Number
1	Nyloc Nut M20	2	0221-NYL20
2	M20 x 110 grade 10.9 ZP Short Thread Bolt	2	0211-20110 ST
3	Disc Chain Spacer	2	0801-PCDCS55

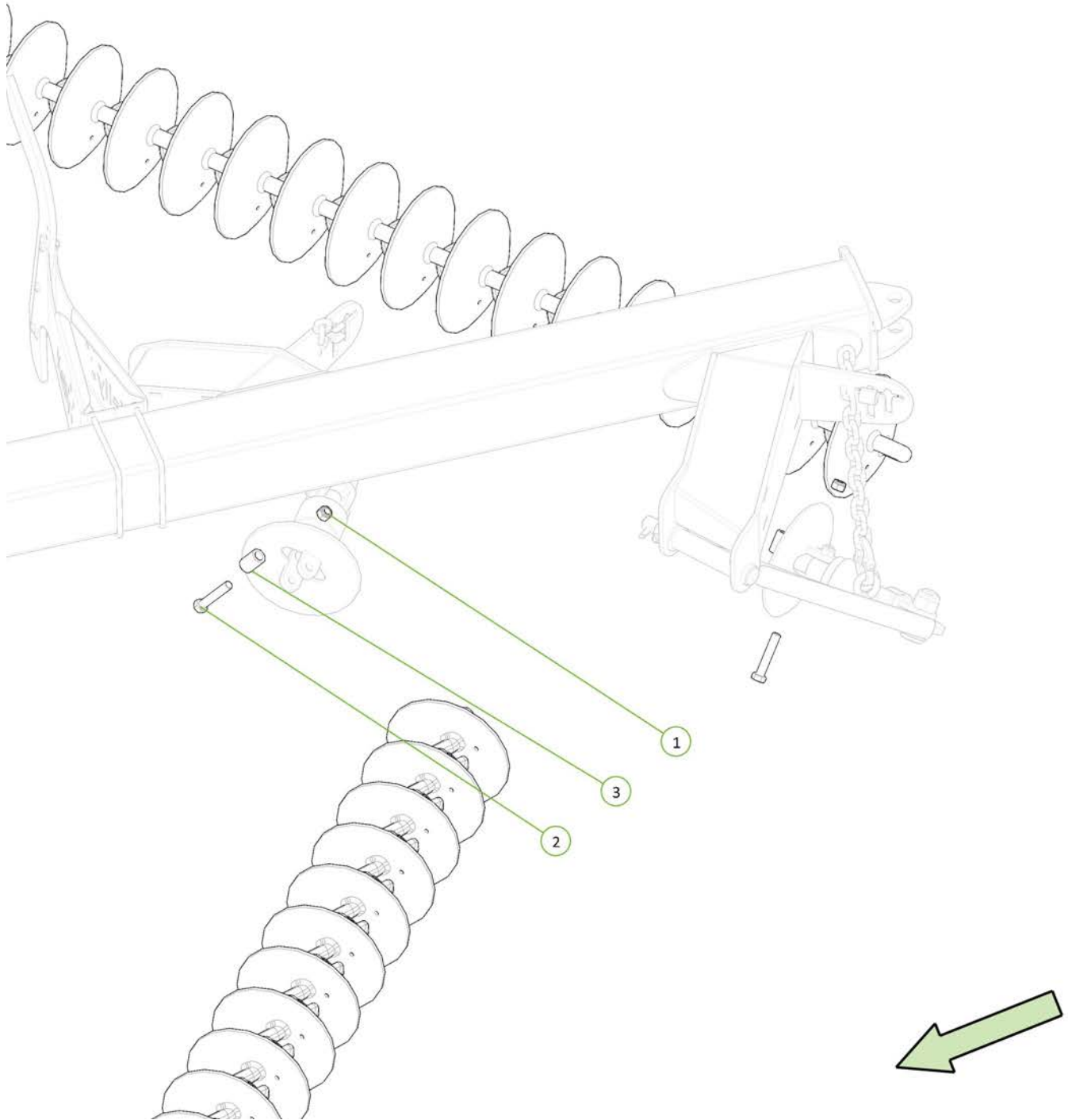



Item No.	Description	Qty	Number
1	Roll Pin Zinc Plated 3/8" x 3"	1	0262-3-8X3

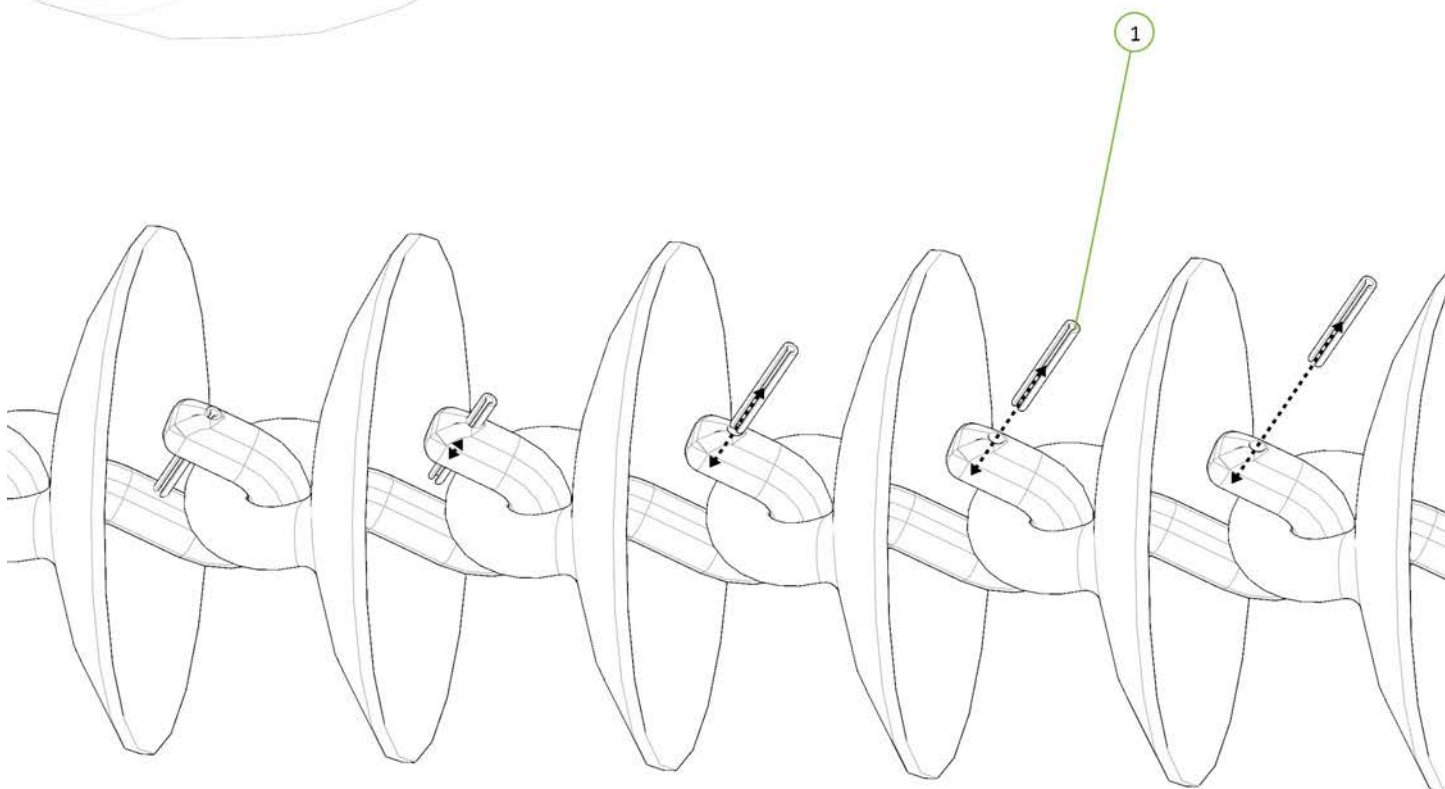

Item No.	Description	Qty	Number
1	M6 x 20mm Trilobe Screw	2	0211-M620MZPHTF
2	Wiring Capping Plate	1	1500-122

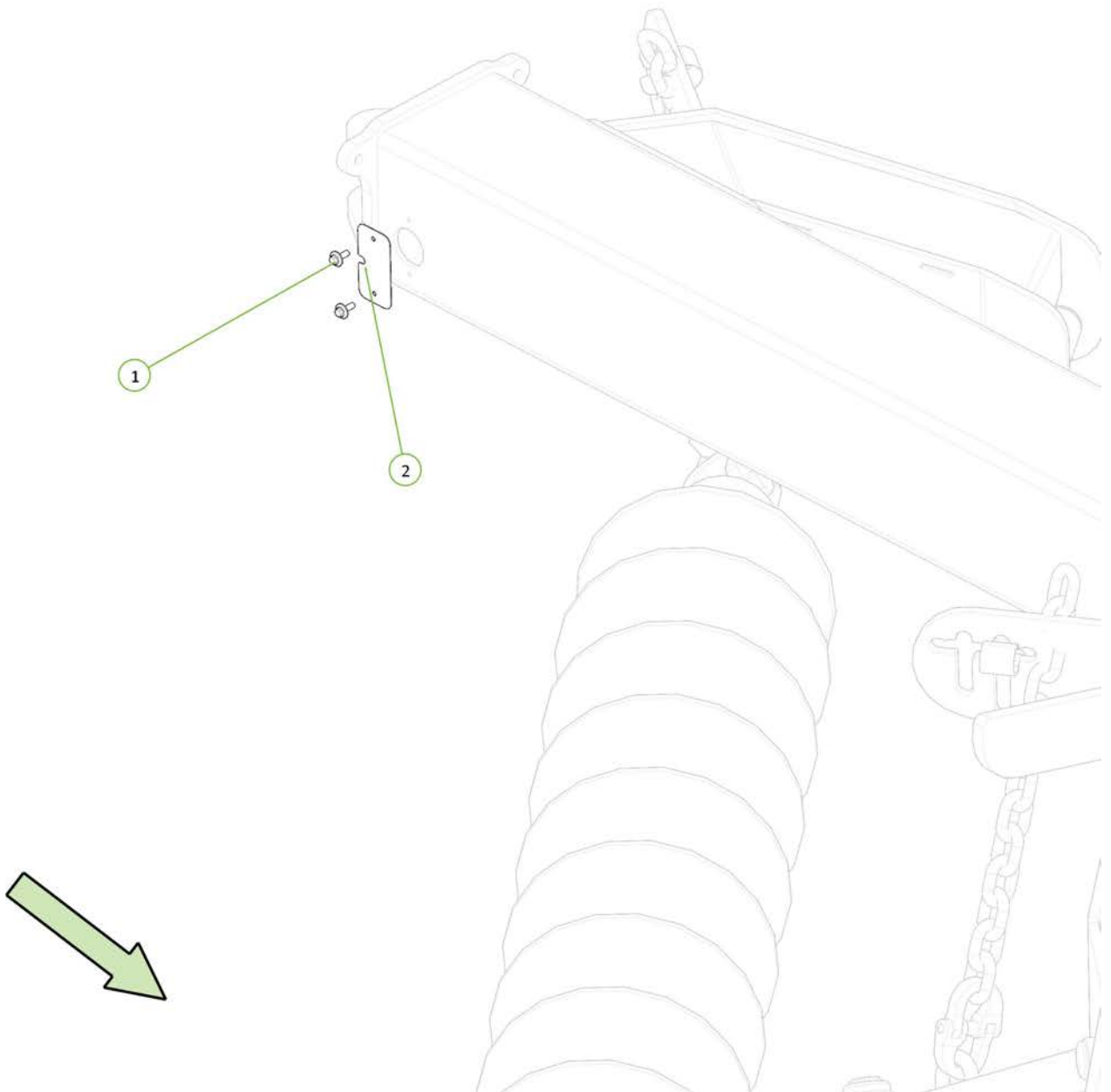

Item No.	Description	Qty	Number
1	Nyloc Nut M12	2	0221-NYL12
2	Sign and Light Bar	1	1510-27
3	M12 x 45 grade 8.8 ZP Bolt	2	0211-1245

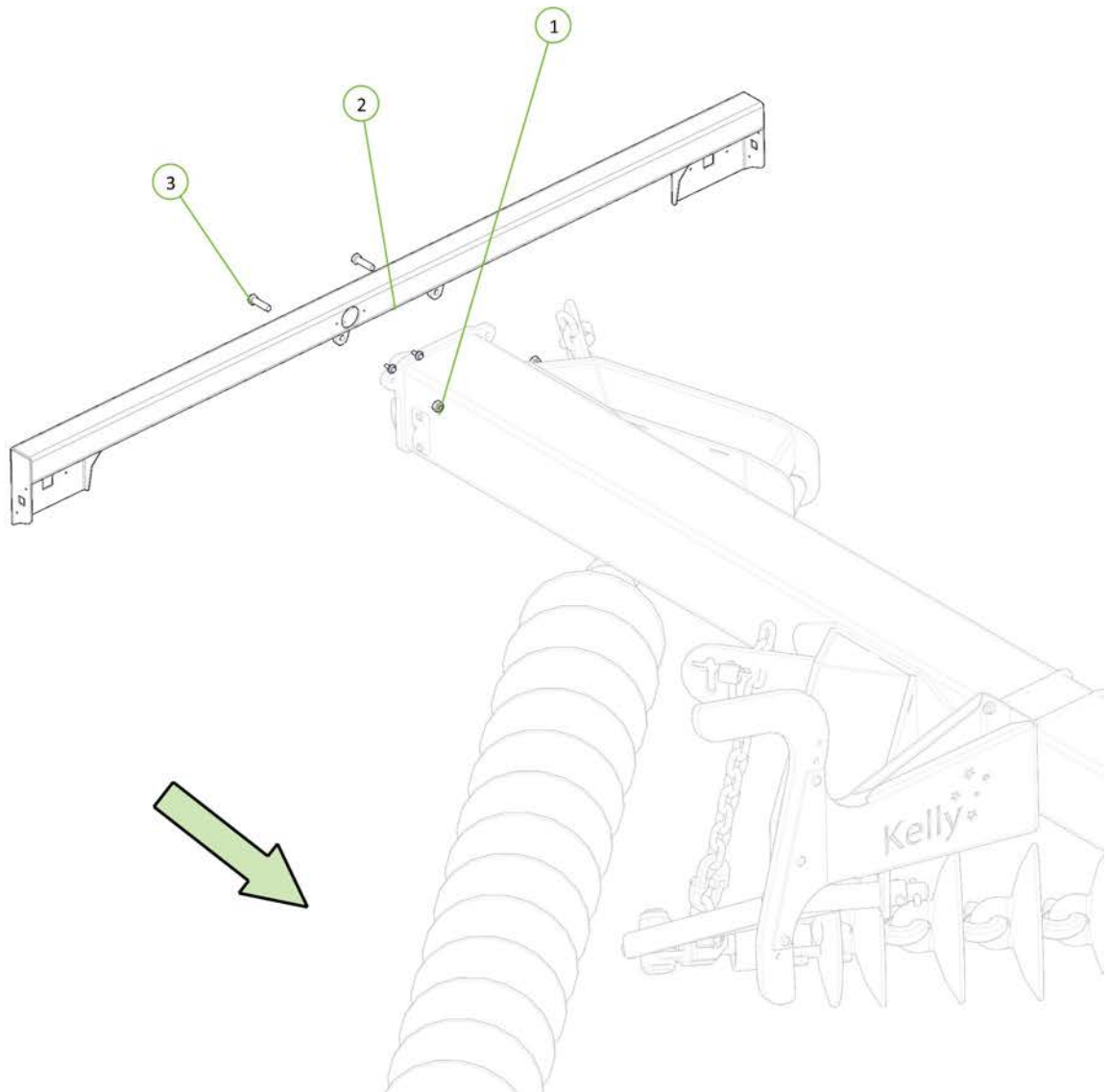

Item No.	Description	Qty	Number
1	LED Rubber Stalk Side Marker Lamp Right	1	0412-1004R
2	LED Rubber Stalk Side Marker Lamp Left	1	0412-1004L
3	LED Combination Tail Light Left	1	0412-EU200L
4	LED Combination Tail Light Left	1	0412-EU200R
5	Nyloc Nut M5	8	0221-NYL5
6	M5 x 0.8 x 20mm Grade 4.6 ZP Bolt	4	0211-520

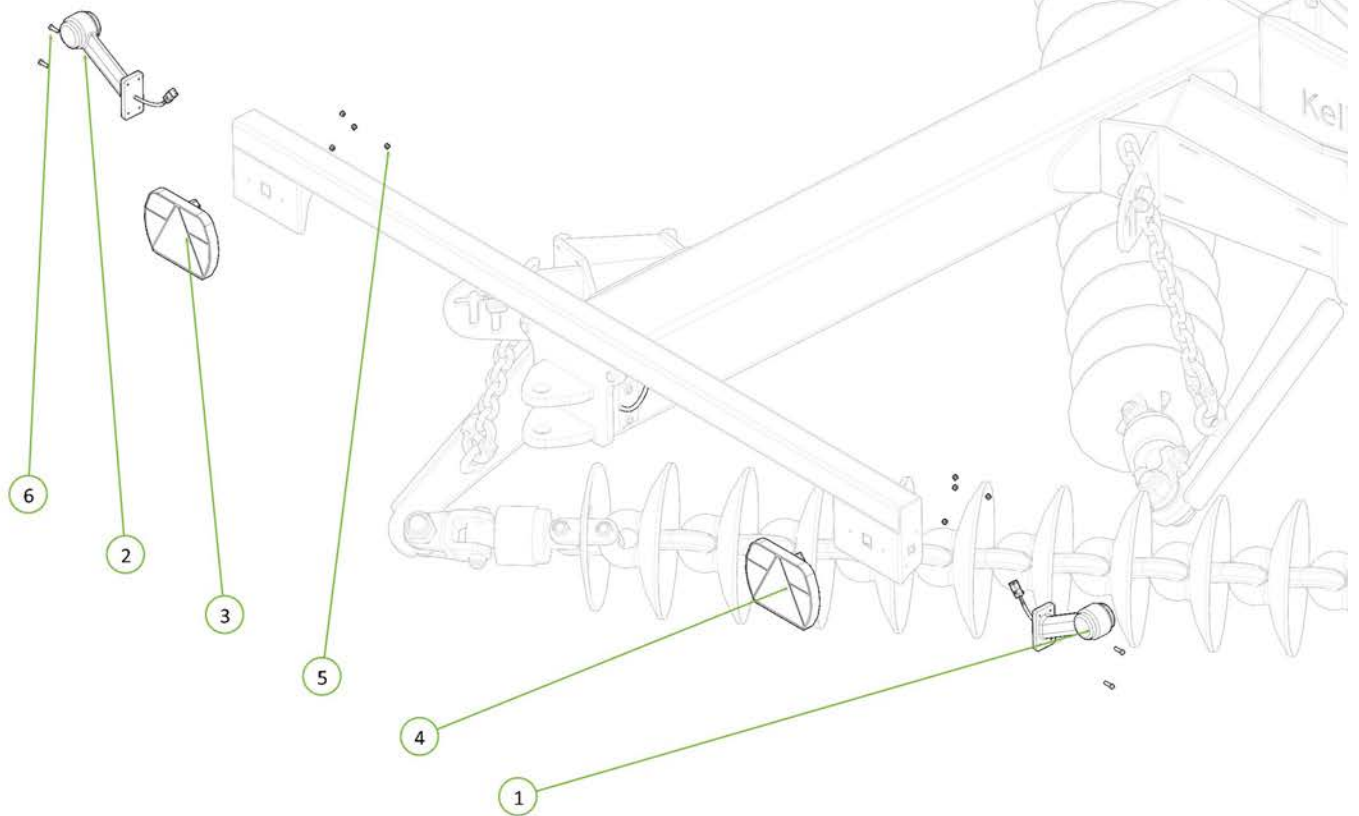

Section 3

Hydraulics

Please Note -

**The black hose/s identifies
the current assembly step**

Item No.	Description	Qty	Number
1	JIC Male UNO Male 90° Elbow	4	0323-S91-1212

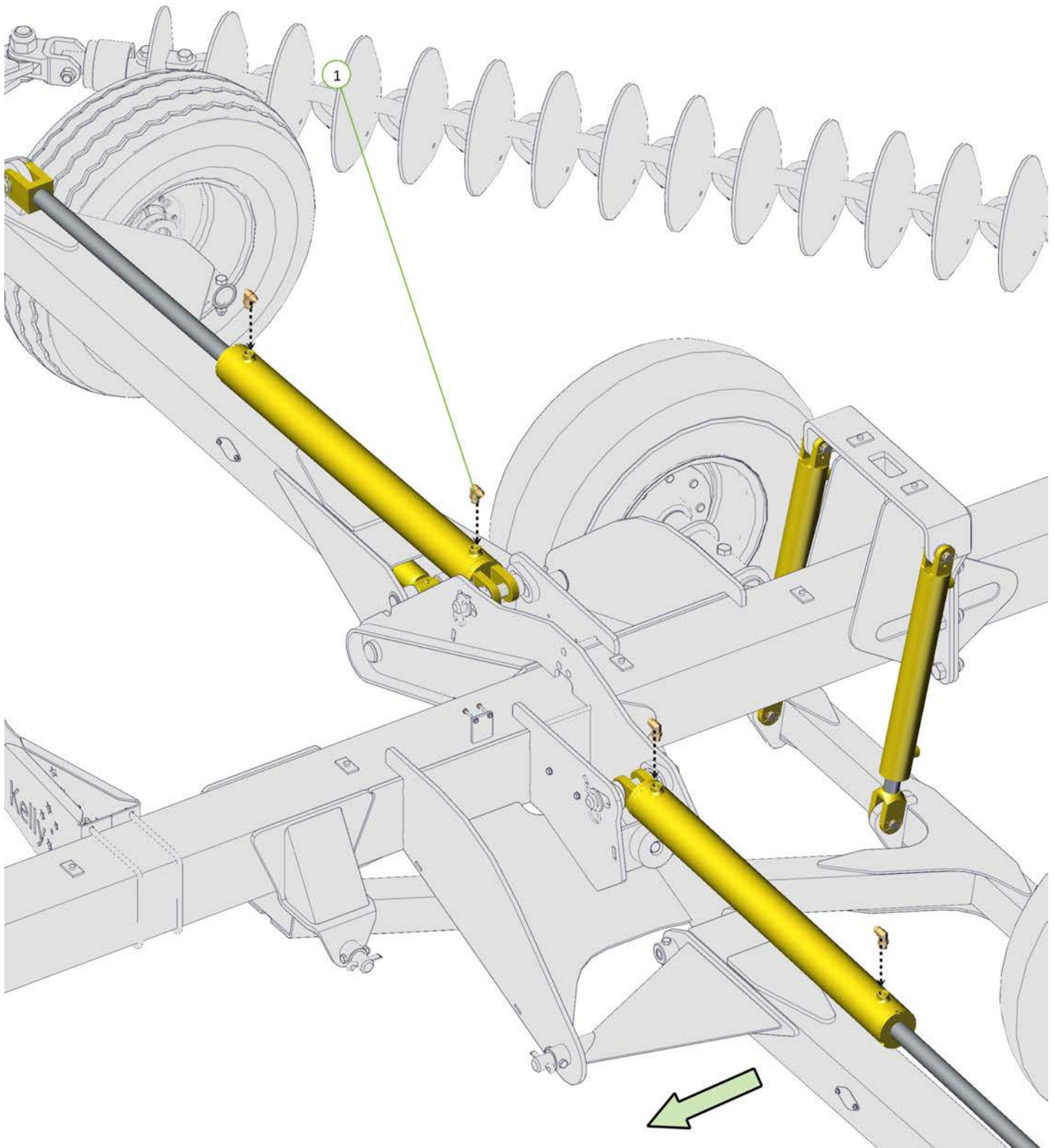

Item No.	Description	Qty	Number
1	6m Wheel Arm Frame	1	1520-10
2	35 ID x 50mm DU Bush	2	0113-MB 3550DU

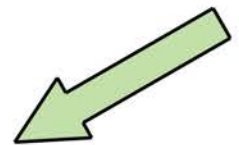
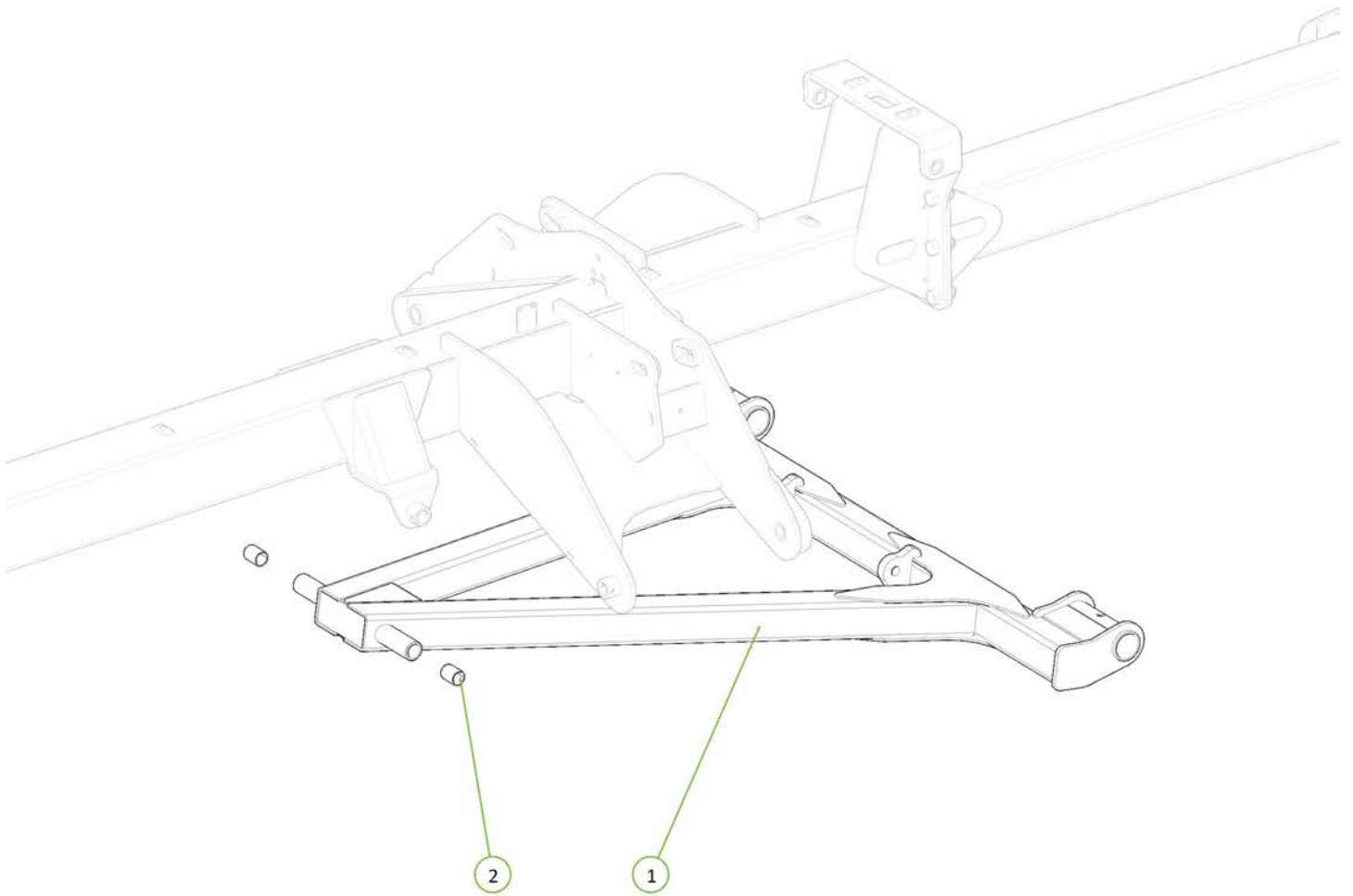

Item No.	Description	Qty	Number
1	JIC Male UNO Male 90° Elbow	2	0323-S91-1212

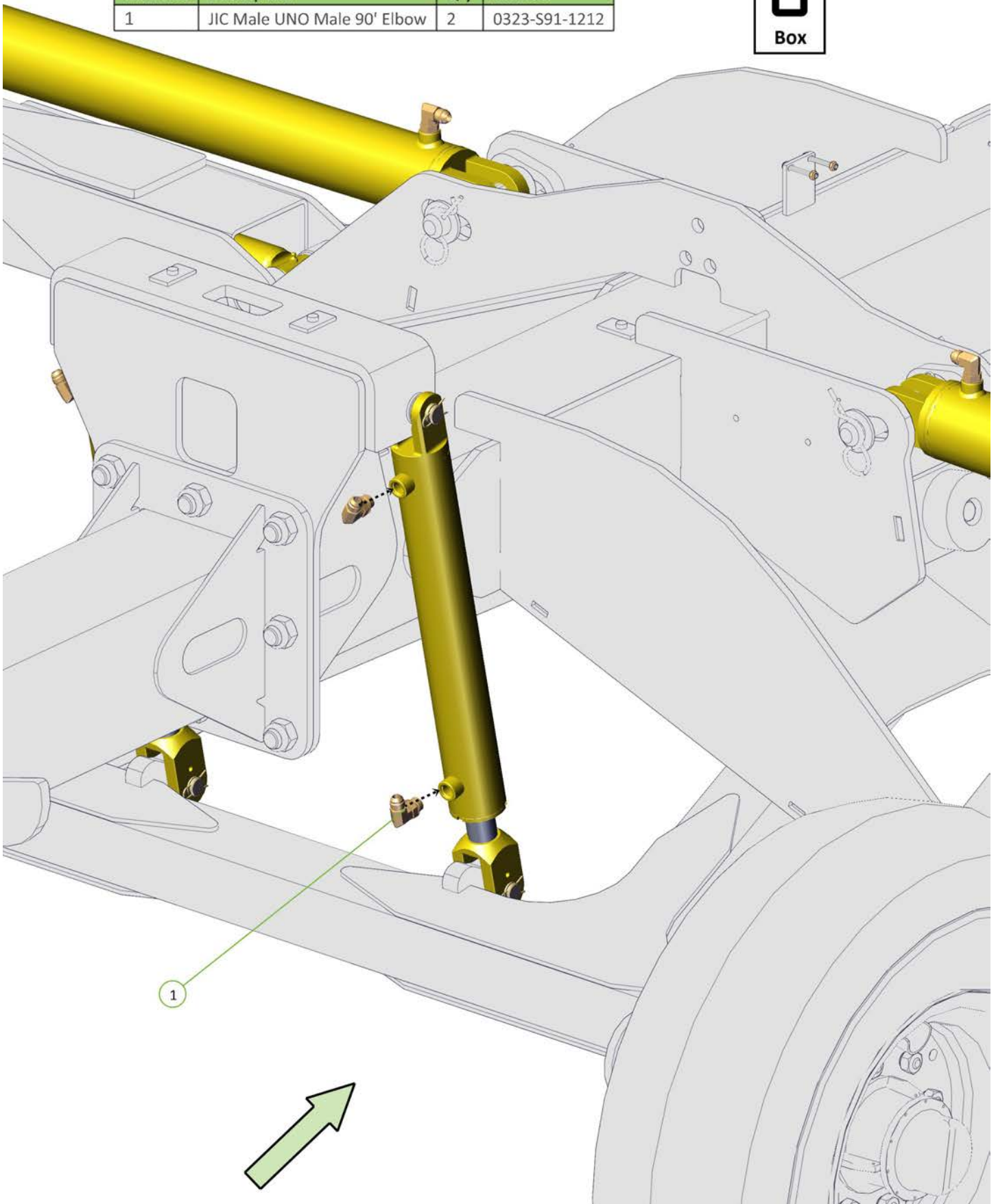

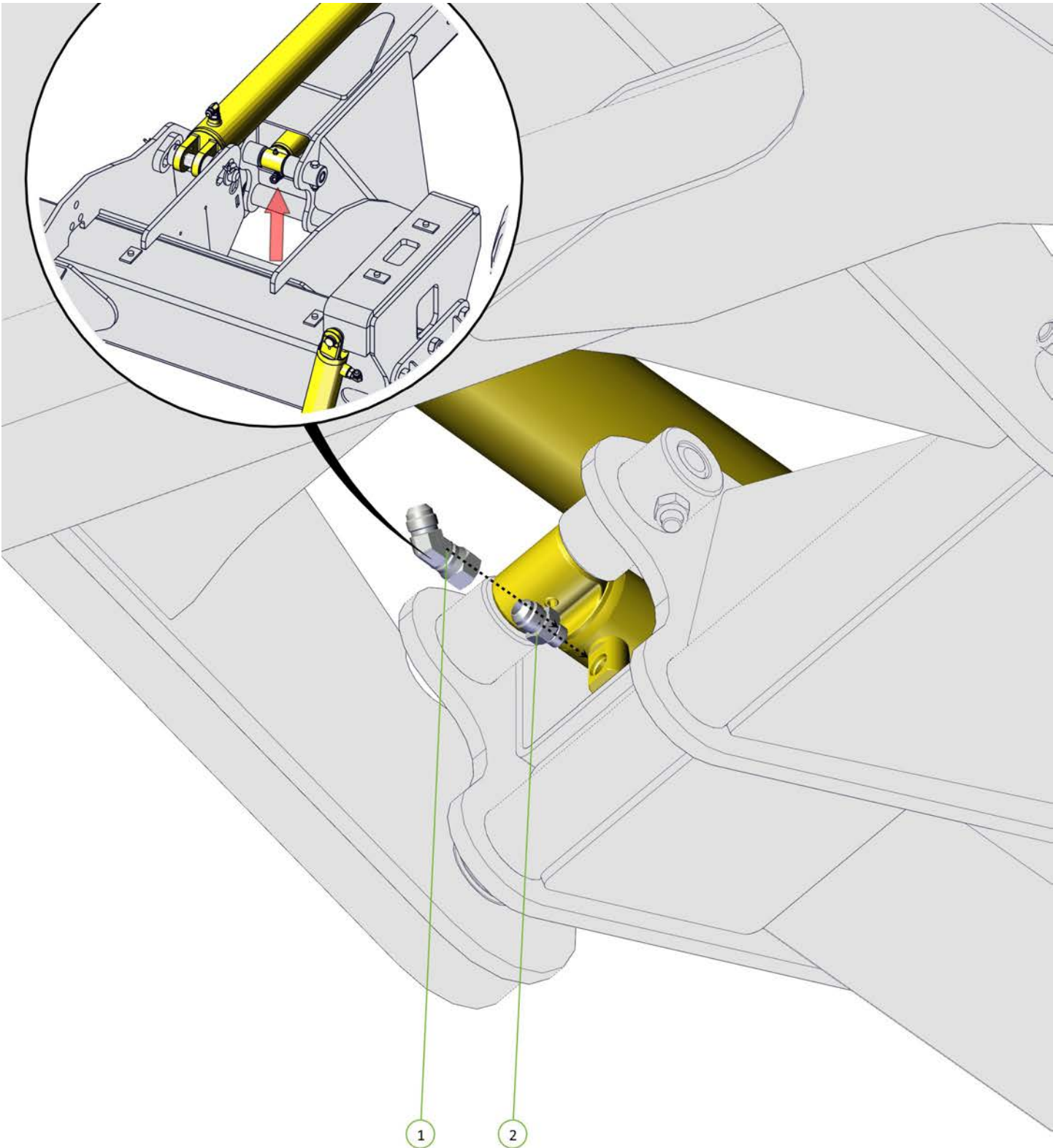

Item No.	Description	Qty	Number
1	JICM JICFS 45' ELBOW	1	0323-S23-1212
2	JICM UNOM NIPPLE	1	0323-S90-1209

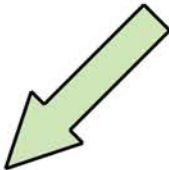

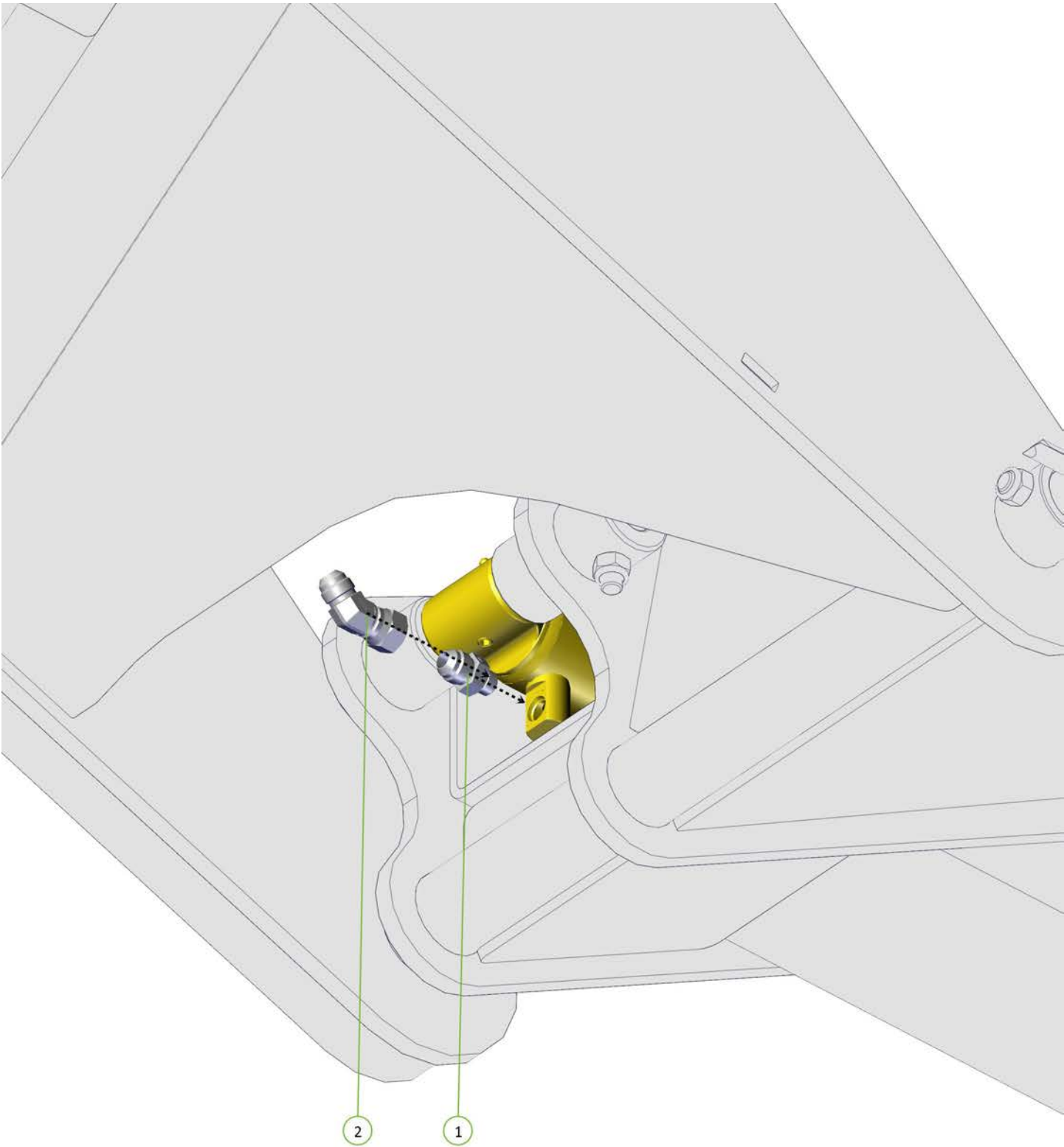

Item No.	Description	Qty	Number
1	JICM UNOM NIPPLE	1	0323-S90-1209
2	JICM JICFS 45' ELBOW	1	0323-S23-1212

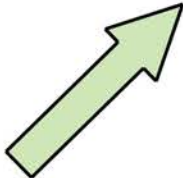

Item No.	Description	Qty	Number
1	M6 x 1 x 85mm Grade 4.6 ZP Bolt	2	0211-685
2	Nyloc Nut M6	2	0221-NYL6
3	BSPP O Ring Male Jic Male Nipple	4	0323-S74-0812
4	Ball Valve BSPP 1/2"	2	0341-RL20SH-0808

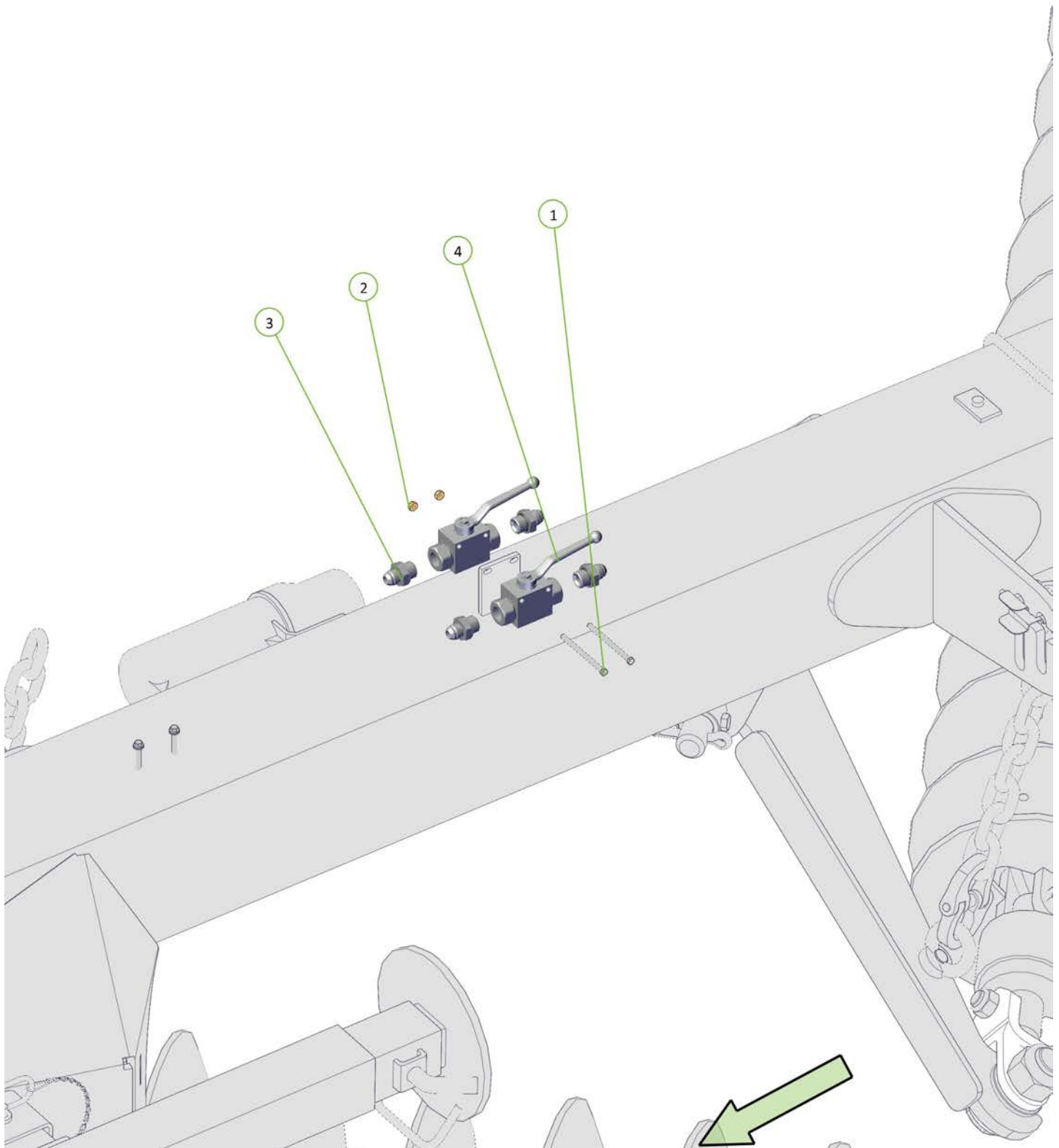
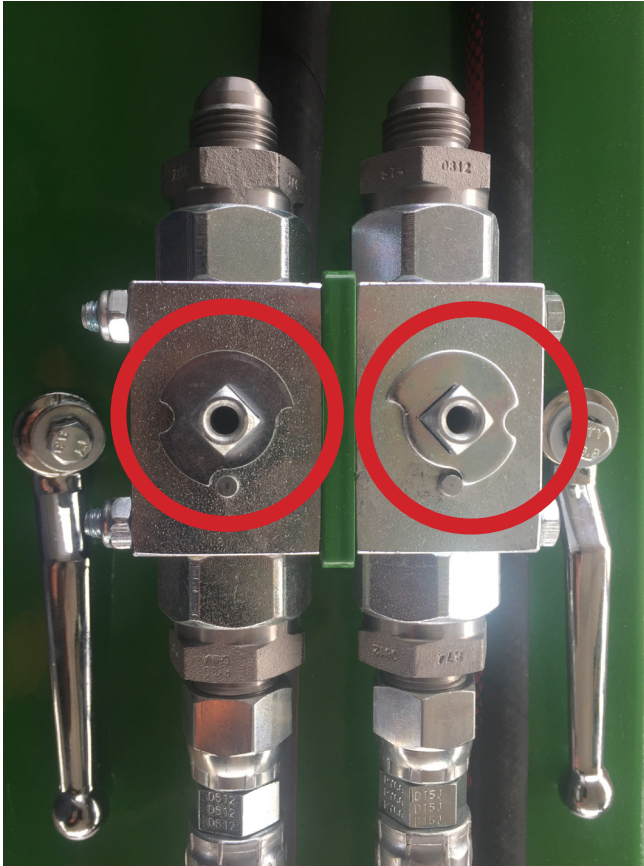

Image 1



Please Note -

1. Unbolt tap handle from tap (as seen in image 1).
2. Flip one plate over so they are a mirror image (as seen in image 1).
3. Bolt tap handle back in original position (as seen in image 2)
4. Correct fitment will ensure taps are closed when both facing outwards on the machine (as seen in image 3).

Image 2



Image 3



Item No.	Description	Qty	Number
1	M6 x 1 x 50mm Grade 4.6 ZP Bolt	2	0211-650
2	Washer Flat M6	2	0231-F6
3	Nyloc Nut M6	2	0221-NYL6
4	Ball Valve BSPP 1/2"	1	0341-RL20SH-0808
5	JICM JICM BSPPOM TEE	1	0324-S79-121208
6	BSPP O Ring Male Jic Male Nipple	1	0323-S74-0812

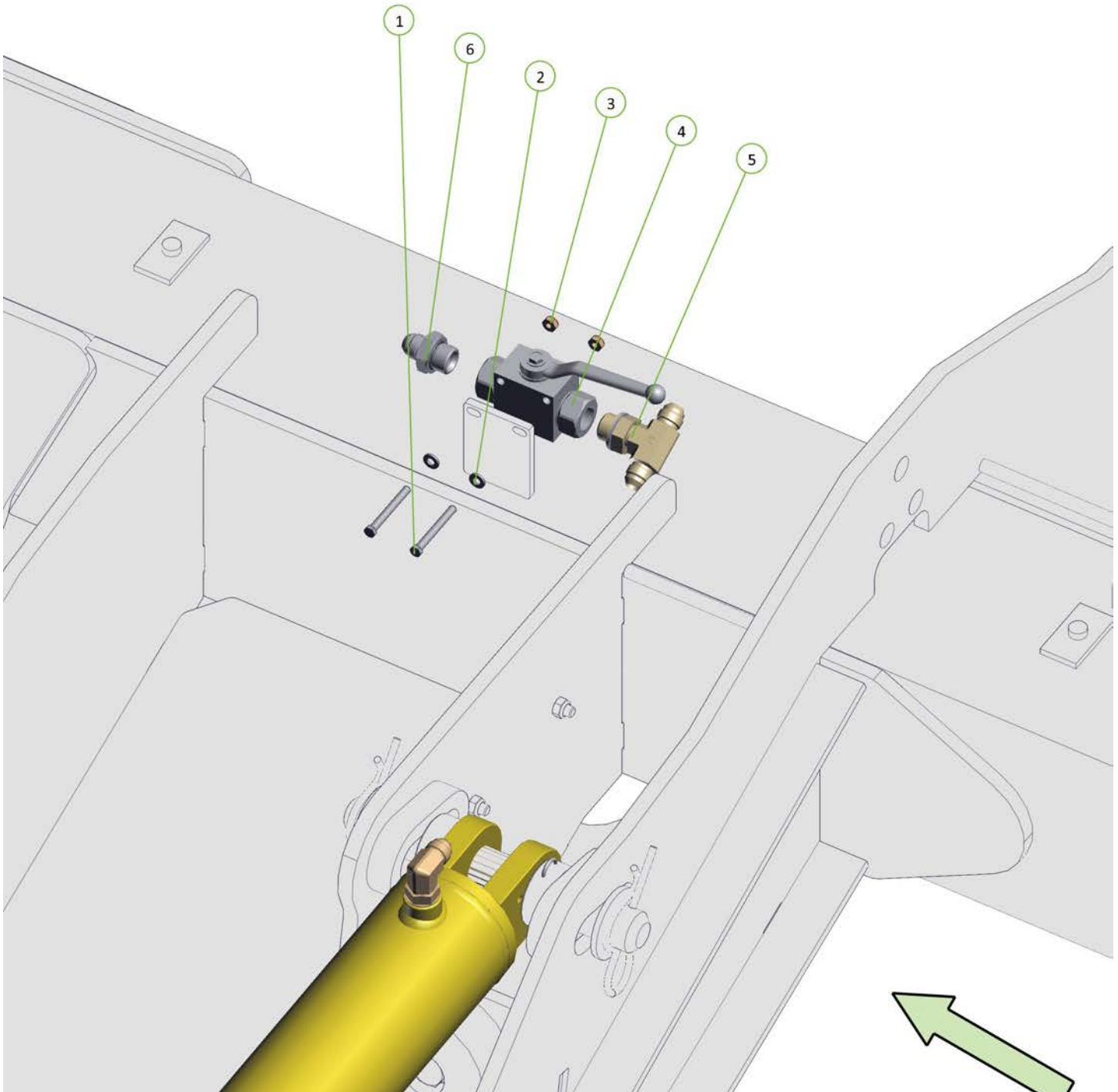

Item No.	Description	Qty	Number
1	M6 x 1 x 50mm Grade 4.6 ZP Bolt	2	0211-650
2	Washer Spring M6	2	0231-S6
3	Washer Flat M6	2	0231-F6
4	JICM UNOM JICM TEE	1	0324-S87-121212
5	Pressure Reducing/Relieving Valve Cartridge	1	0341-PR50-36A0P30
6	JIC Male UNO Male 90' Elbow	1	0323-S91-1212
7	10-Size 3-way Valve Housing	1	0341-7024380

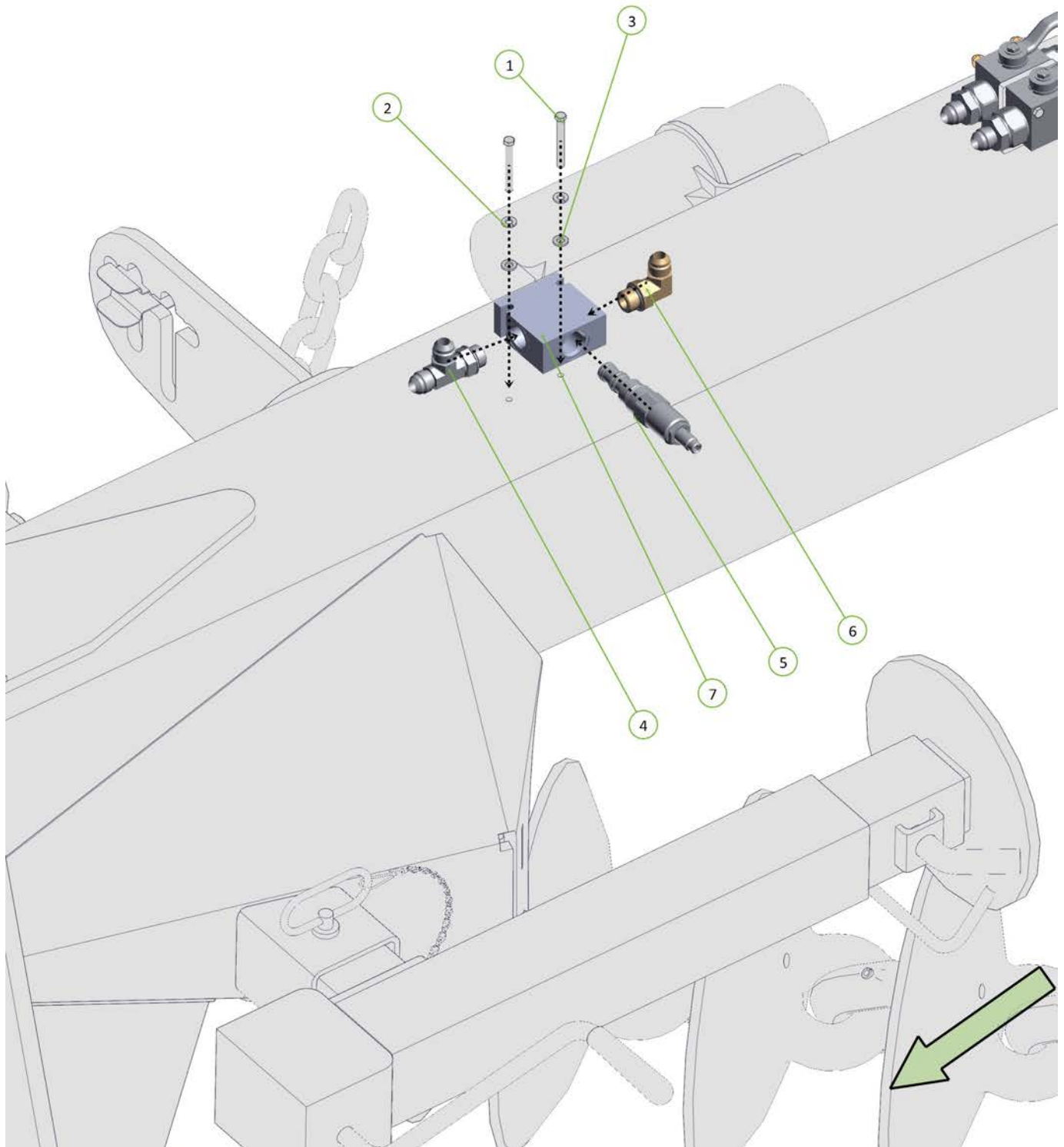

Item No.	Description	Qty	Number
1	JICM JICM JICFS TEE	2	0324-S68-121212
2	JICM JICM JICM TEE	1	0324-S19-121212
3	3/4" JIC Female Nut & Swivel	2	0323-S6-1208
4	ACCUM-VALVE-P2	1	0323-ACCUM-VALVE-P2
5	BSP POM JICM 90° ELBOW	1	0323-S76-0612
6	3/8" BSP Port Check Valve	1	0341-RCV-0606
7	BSP POM JICFS ADAPTOR	1	0323-S71-0612
8	JIC FEMALE UNO RING MALE	1	0323-S101-1212

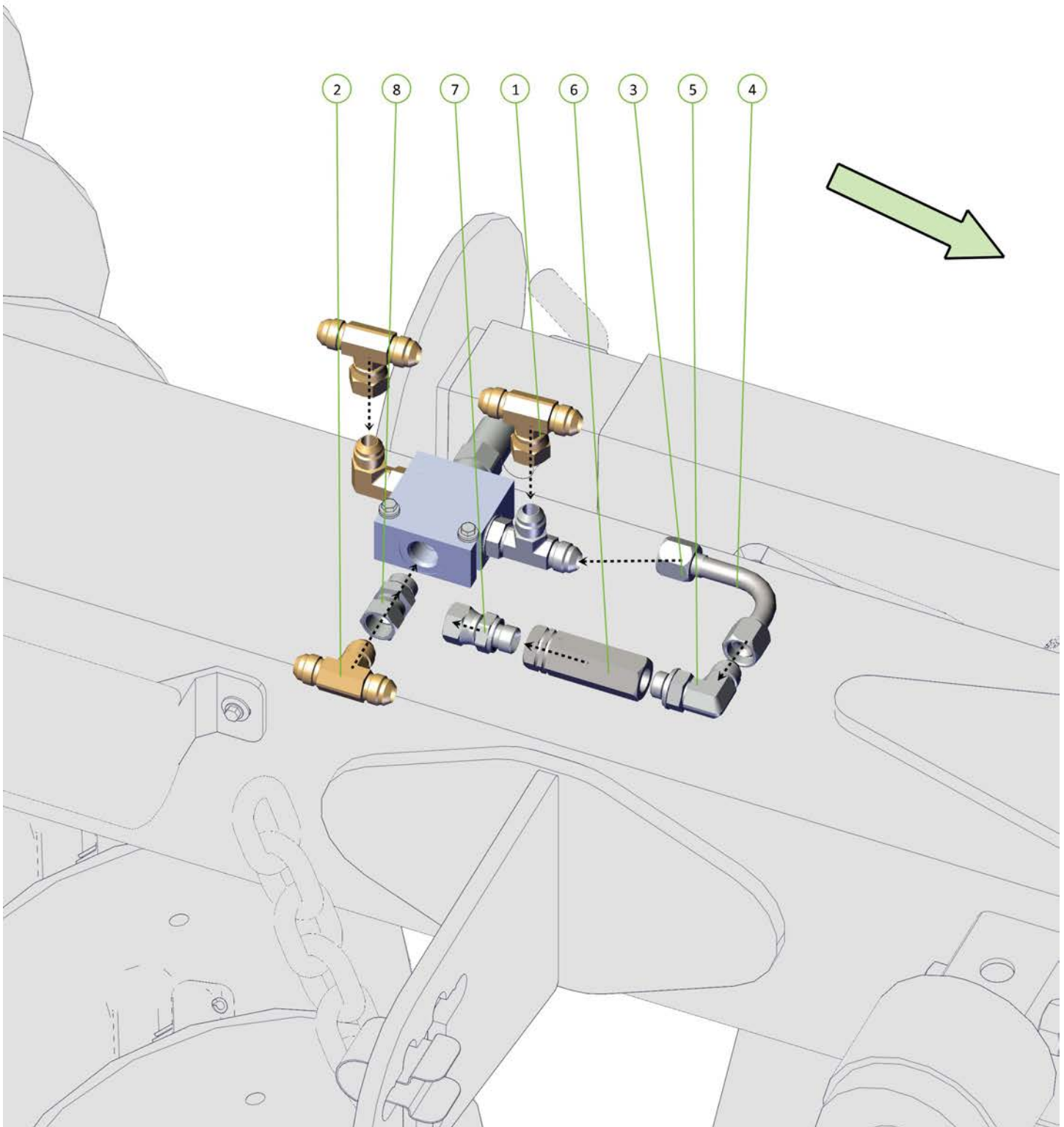

Item No.	Description	Qty	Number
1	Nyloc Nut M8	2	0221-NYL8
2	M8 x 30 grade 8.8 ZP Bolt	2	0211-830
3	Washer Flat M8	2	0231-F8
4	HYRAC 143-151 (151)	1	0343-ACCUCLAMP-143-151

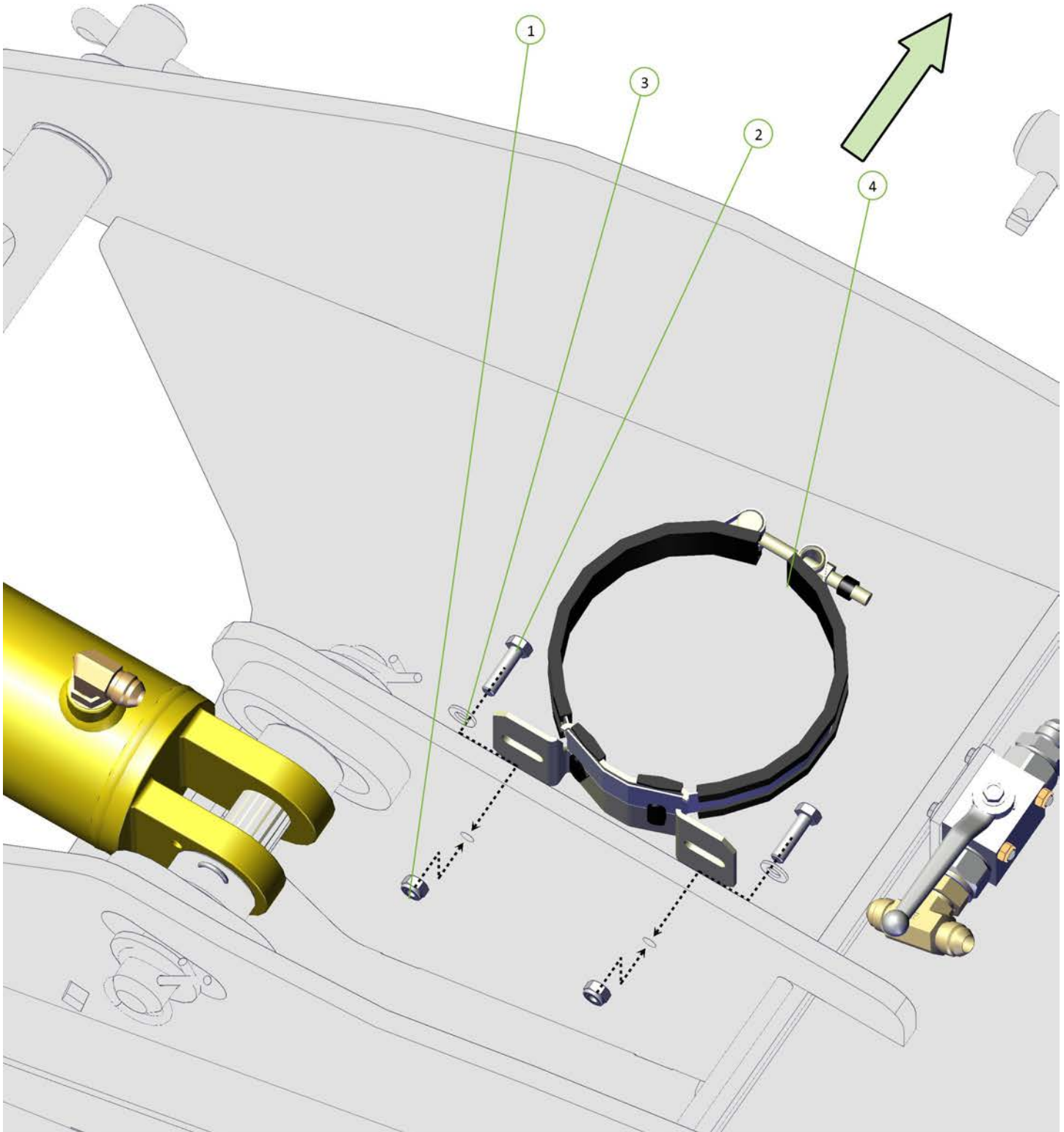

Item No.	Description	Qty	Number
1	1.4L Accumulator	1	0343-SBO210-1.4EI
2	JICM JICM BSPPOM TEE	1	0324-S79-121208

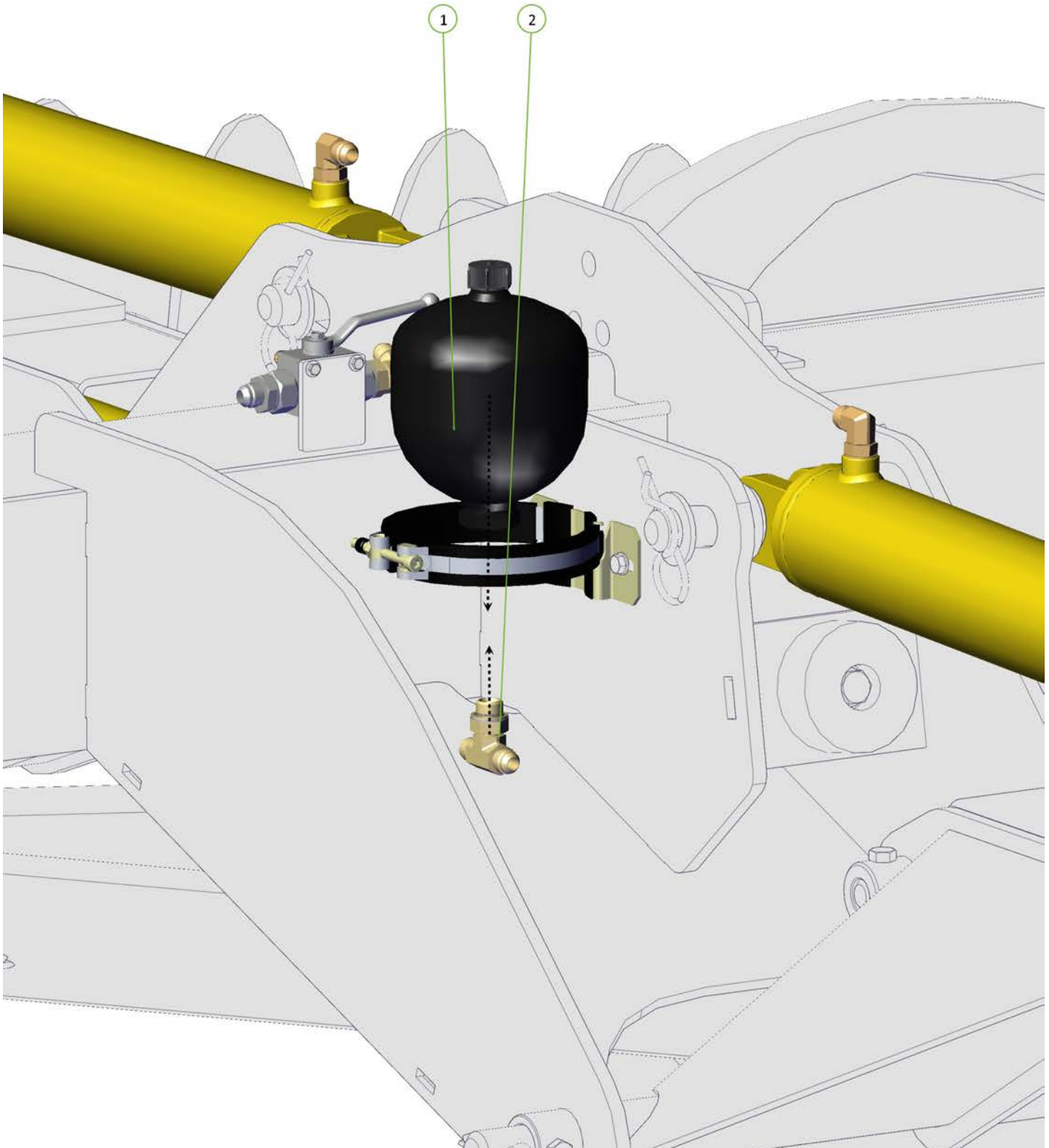

Item No.	Description	Qty	Number
1	RCD Double Clamp Jaws 17mm	3	0325-RCD-17J
2	Double Clamp Stacking Plate (Non Ryco)	2	0325-SI-2-5D-W3
3	RCD Double Clamp Stacking Bolt No 2	2	0325-RCD-2BS
4	RCD Double Clamp Bolt No 2	1	0325-RCD-2BH
5	RCD Double Clamp Top Plate No 2	1	0325-RCD-2PT

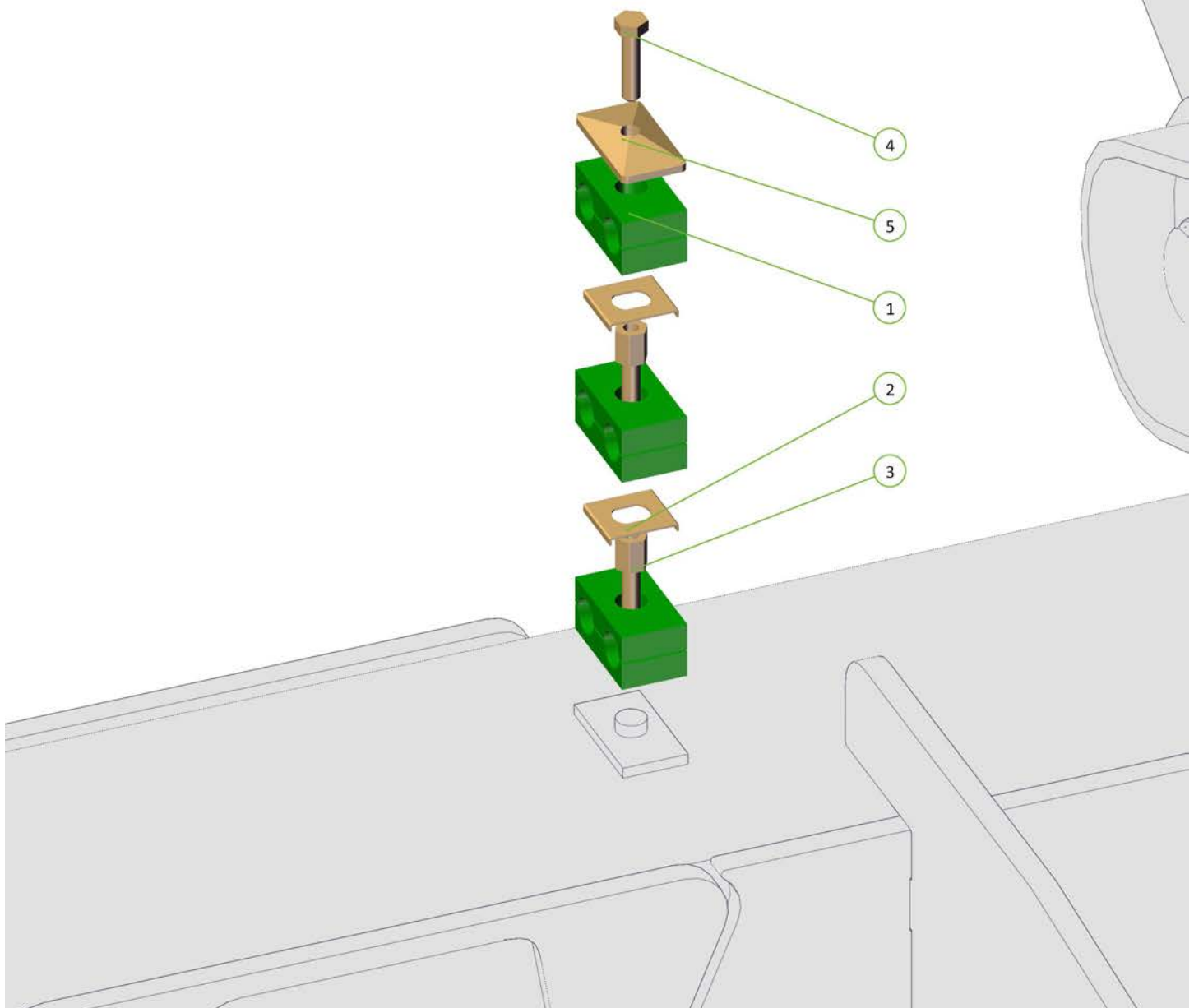

Item No.	Description	Qty	Number
1	Tractor to Main Pressure Relief Extend	1	H6-02-GE
2	BSPPF QRC/BALL MALE TIP	1	0325-R91-08M

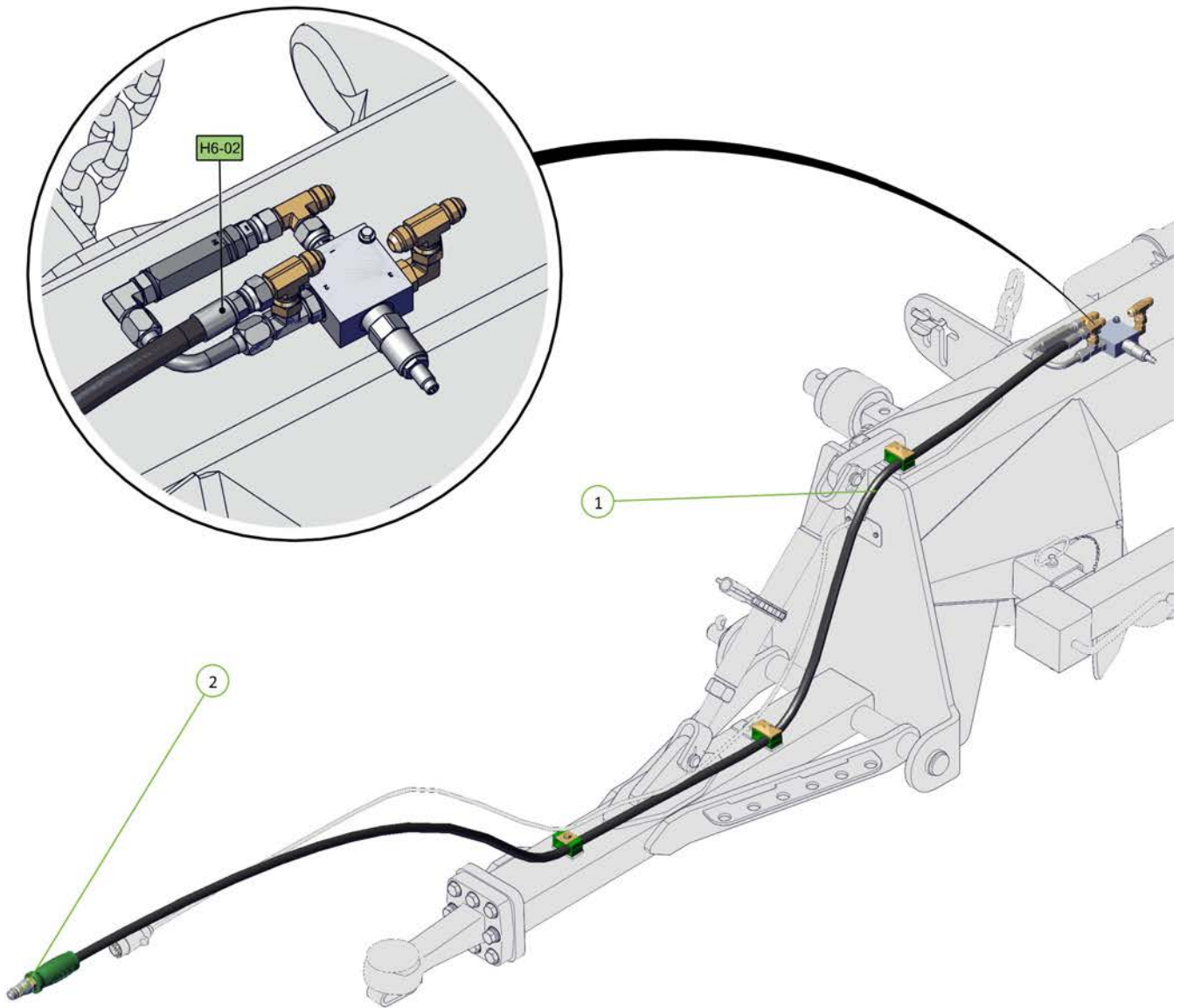

Item No.	Description	Qty	Number
1	Tractor to Wheel Retract	1	H6-11-YR
2	BSPPF QRC/BALL MALE TIP	1	0325-R91-08M

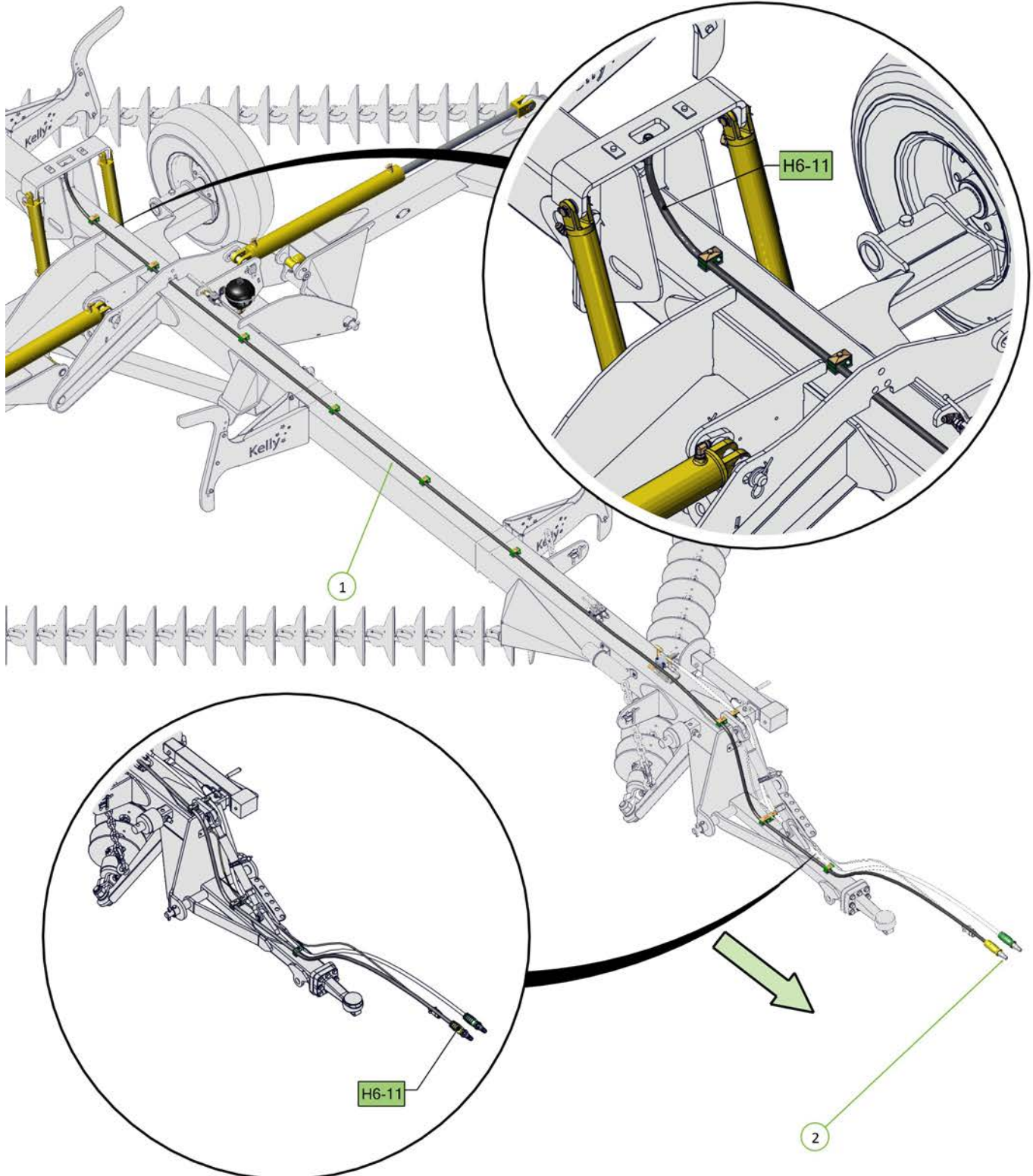

Item No.	Description	Qty	Number
1	Tractor to Pressure Relief Valve Retract	1	H6-03-GR
2	BSPPF QRC/BALL MALE TIP	1	0325-R91-08M

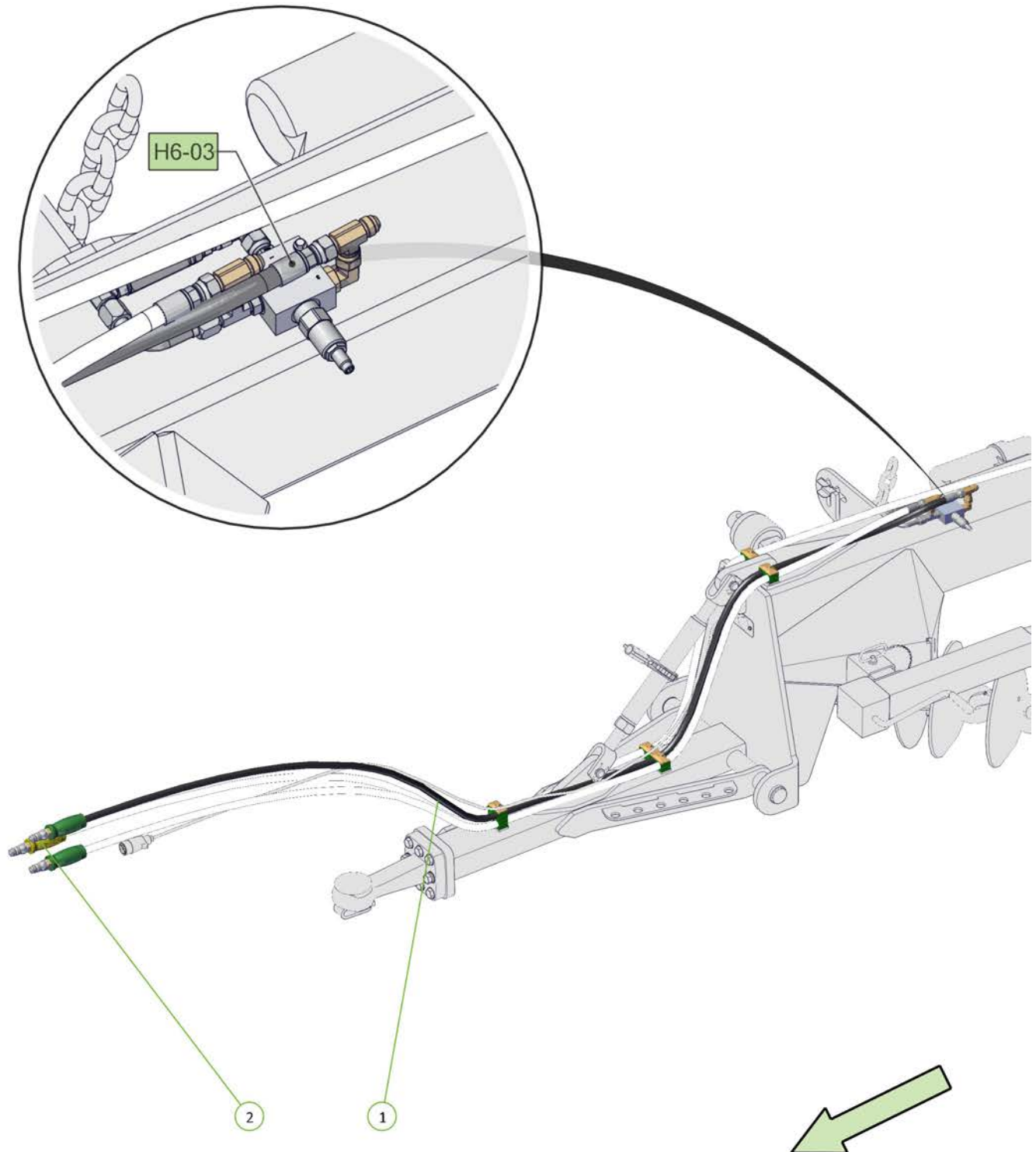

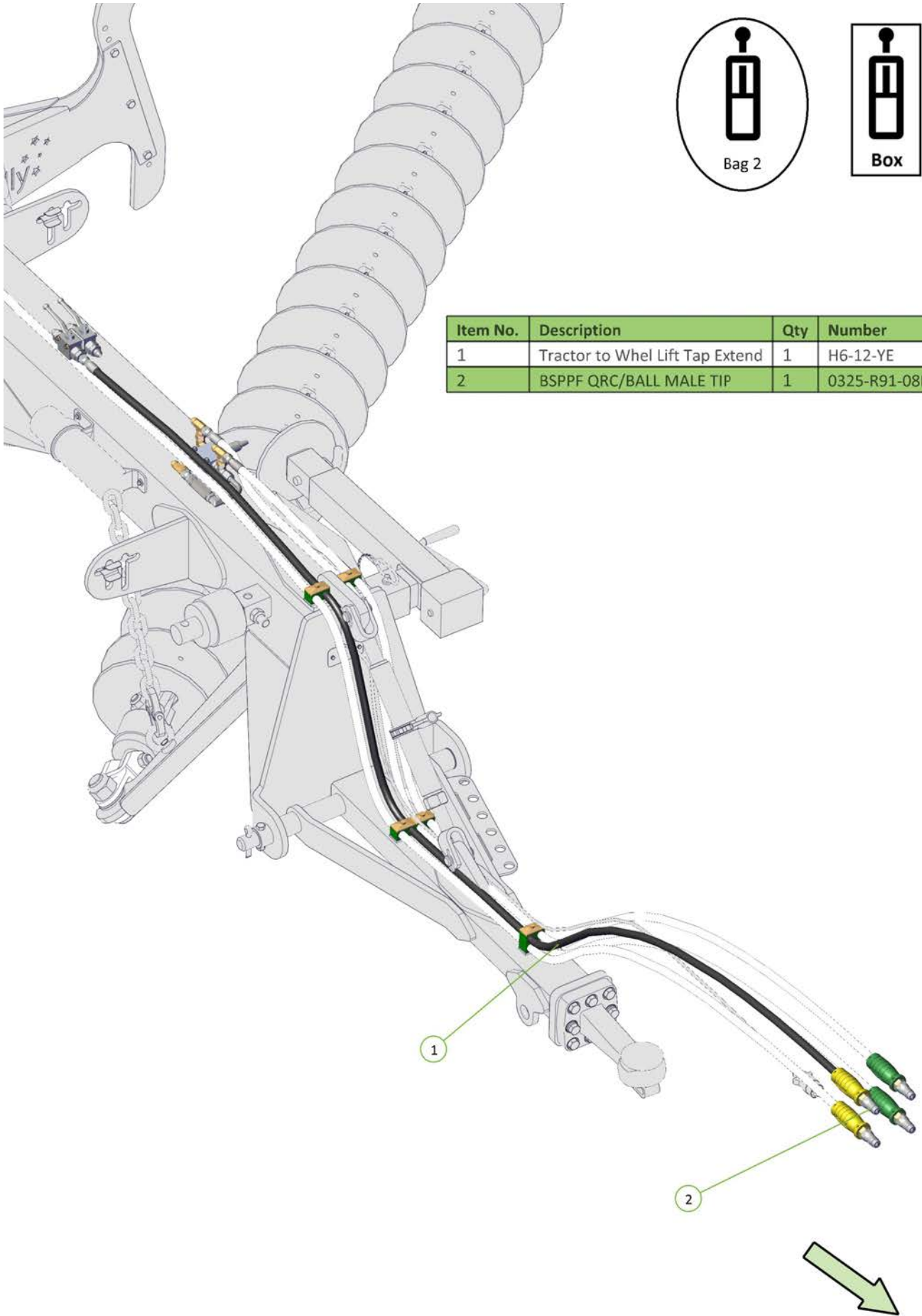

Item No.	Description	Qty	Number
1	Tractor to Whel Lift Tap Extend	1	H6-12-YE
2	BSPPF QRC/BALL MALE TIP	1	0325-R91-08M

Item No.	Description	Qty	Number
1	Pressure Relief Valve to Tap Retract	1	H6-06

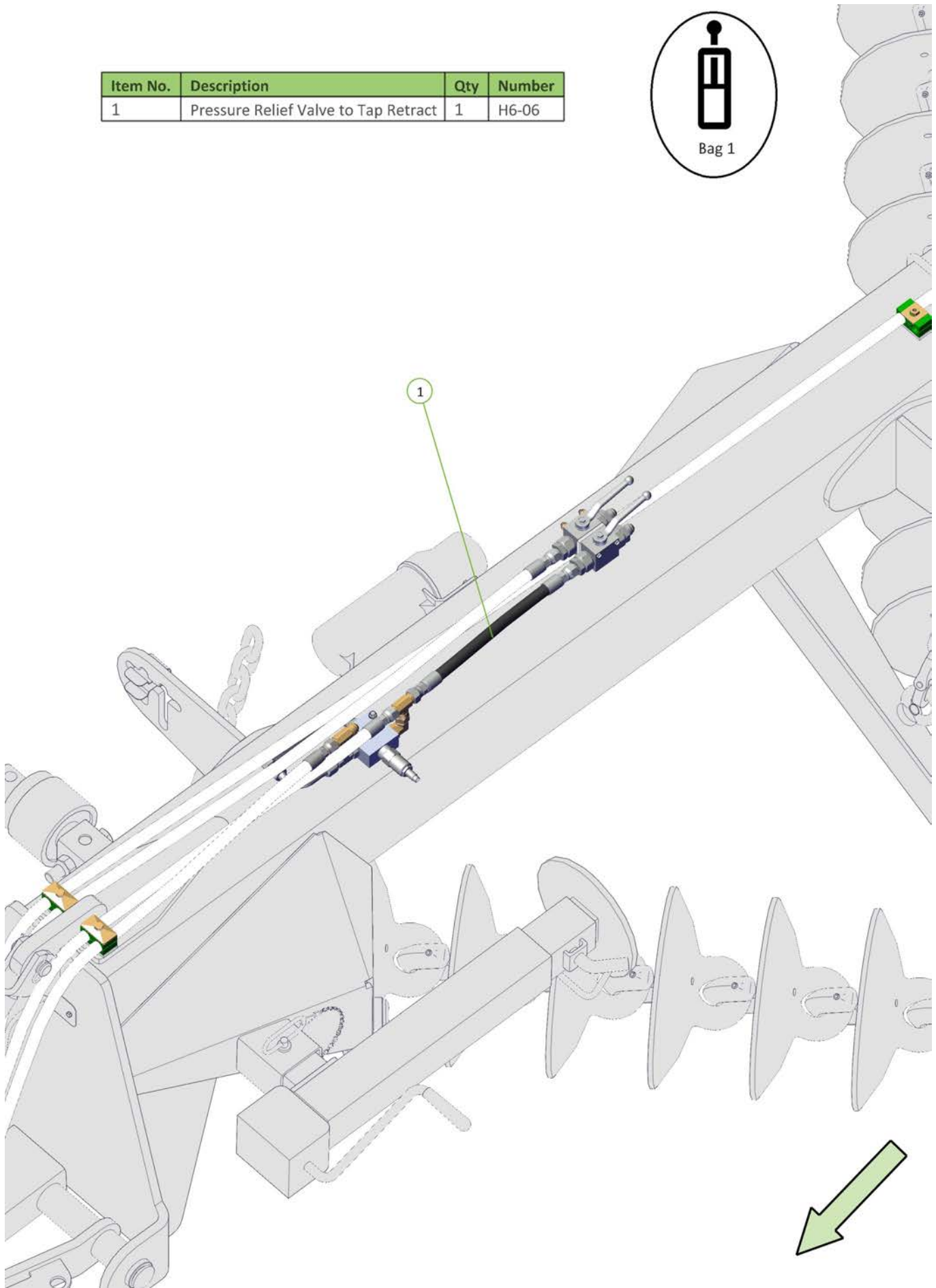

Item No.	Description	Qty	Number
1	Pressure Relief Valve to Bulk Head Fitting Extend	1	H6-05
2	3/4" JIC Male Bulkhead Fitting	1	0324-S62-121212

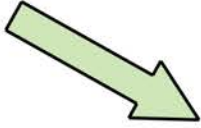
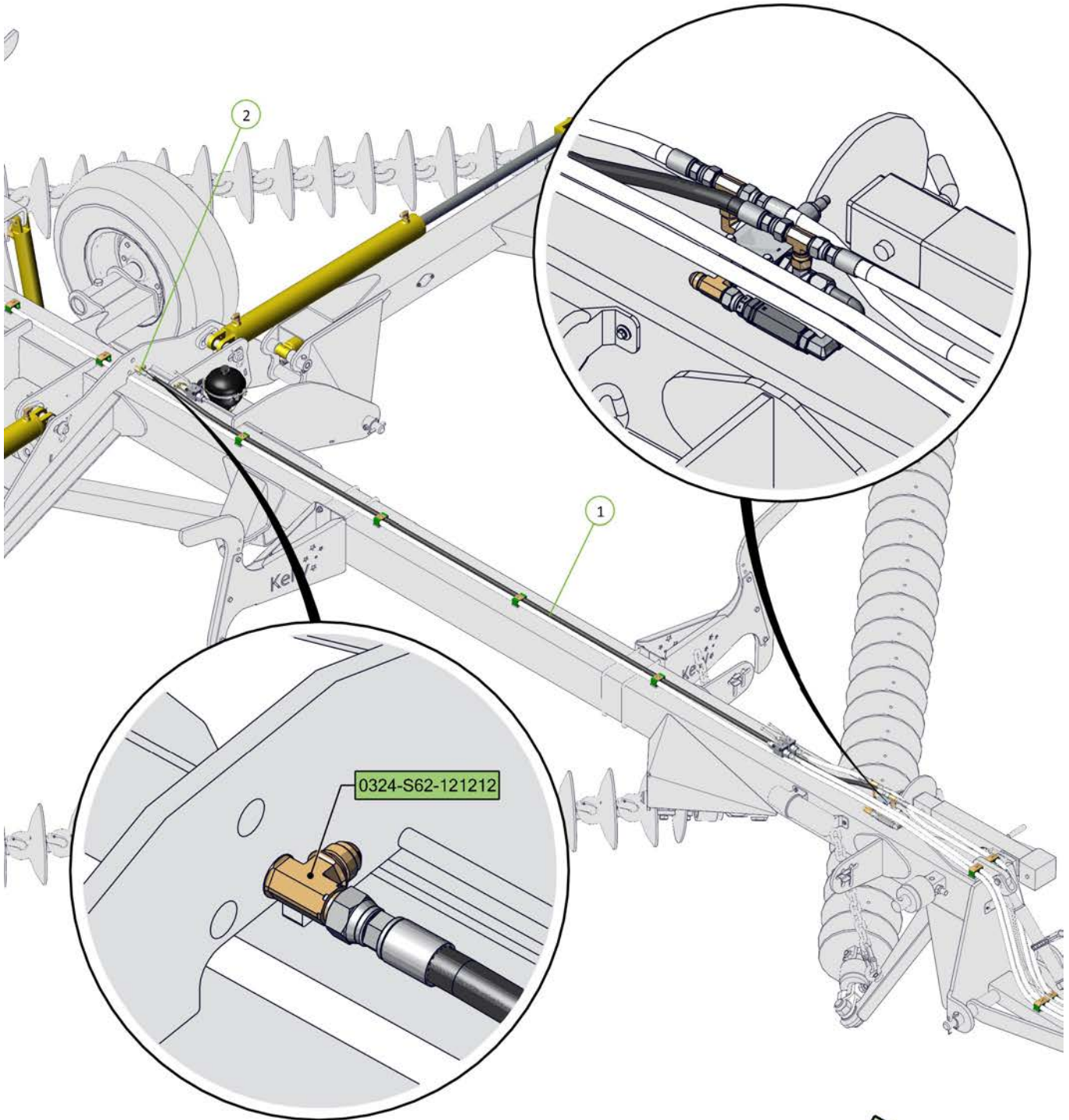

Item No.	Description	Qty	Number
1	Wheel Lift Tap to Wheel Lift Extend	1	H6-13

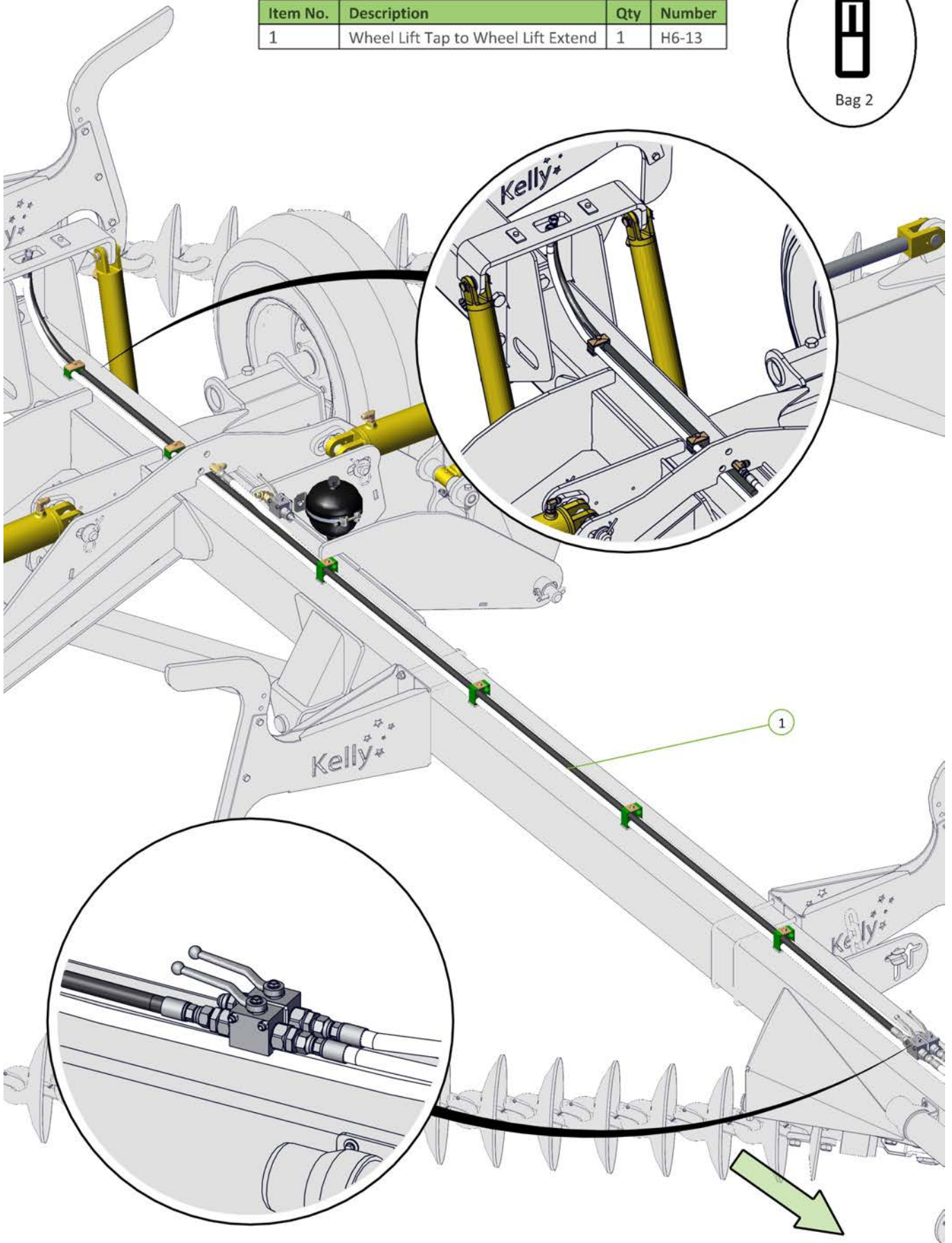

Item No.	Description	Qty	Number
1	Tap to Bulk Head Fitting Retract	1	H6-04
2	3/4" JIC Male Bulkhead Fitting	1	0324-S62-121212

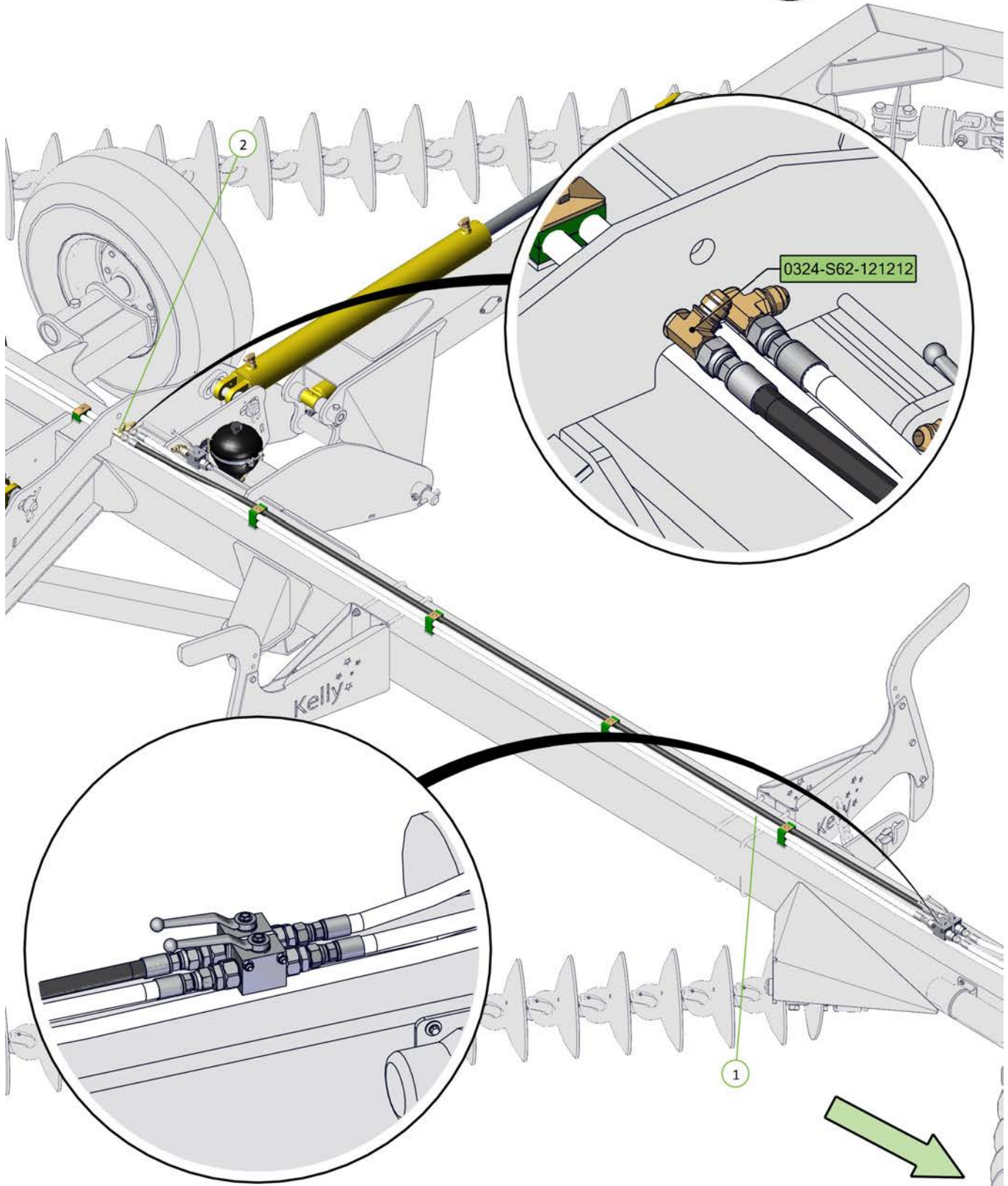

Item No.	Description	Qty	Number
1	Pressure to Tap	1	H6-20

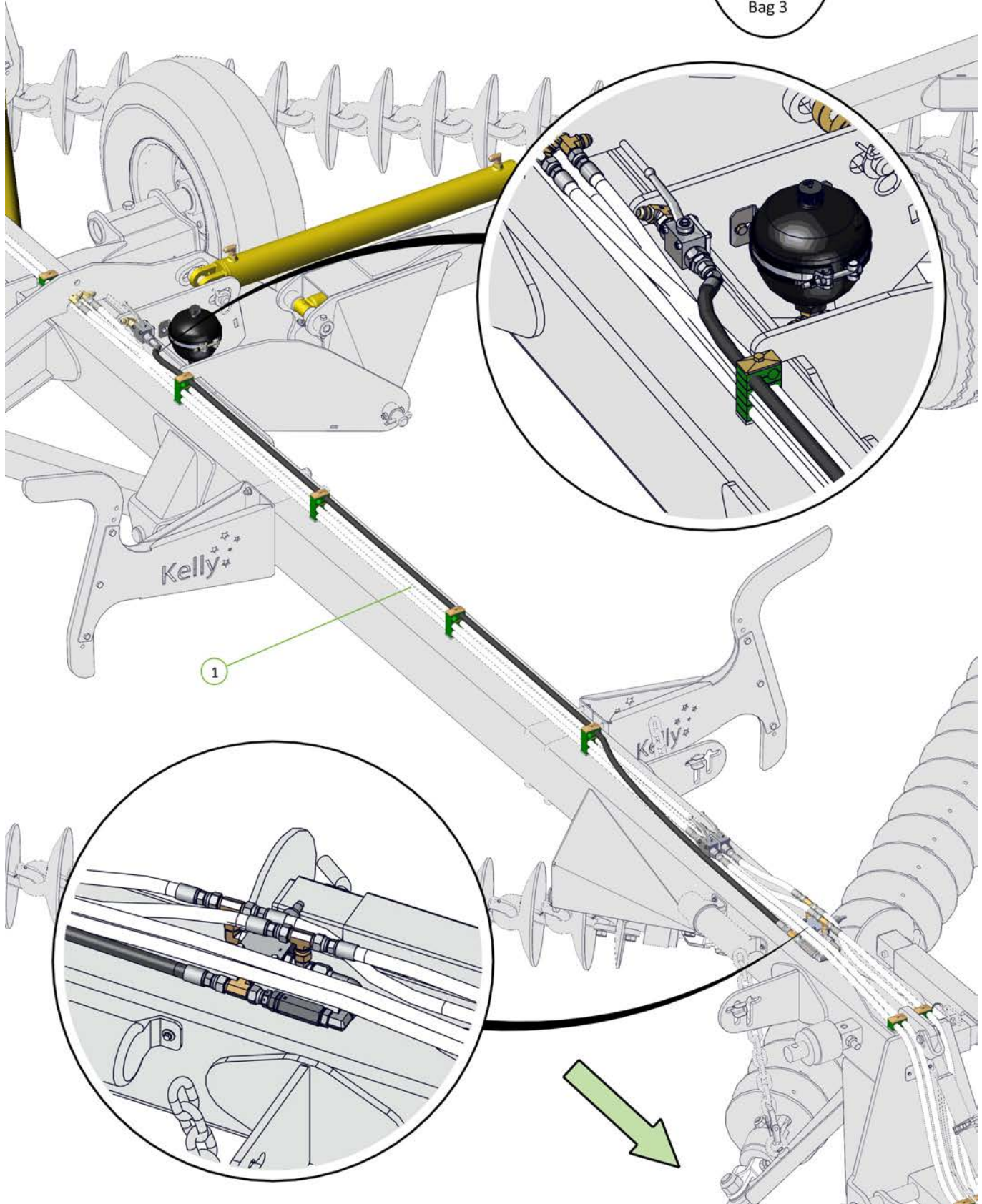

Item No.	Description	Qty	Number
1	Tension Tap to Bulkhead Fitting	1	H6-18
2	JICM BULKHEAD JICM NIPPLE	1	0323-S10-1212

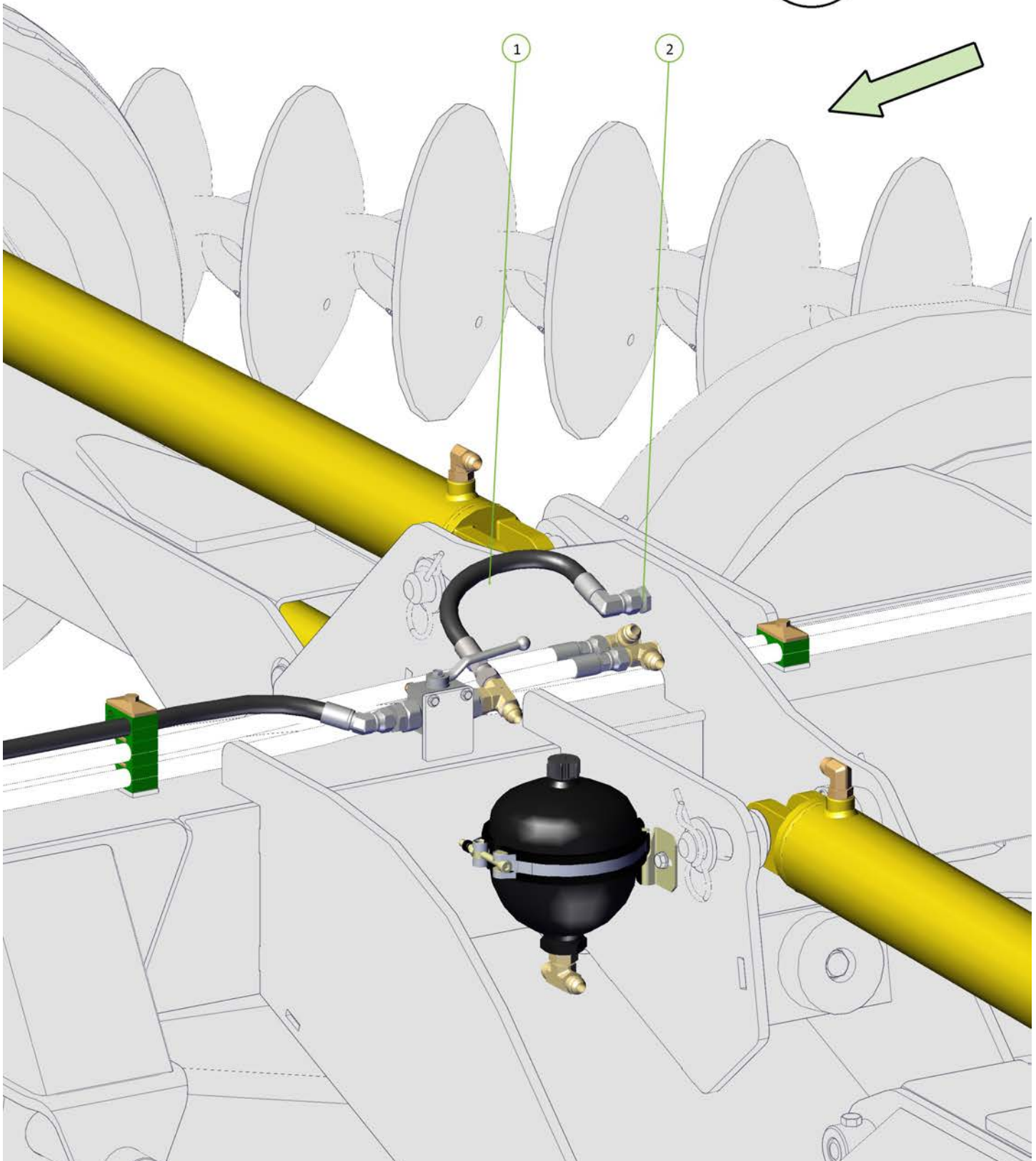

Item No.	Description	Qty	Number
1	Tension Tap to Accumulator	1	H6-16

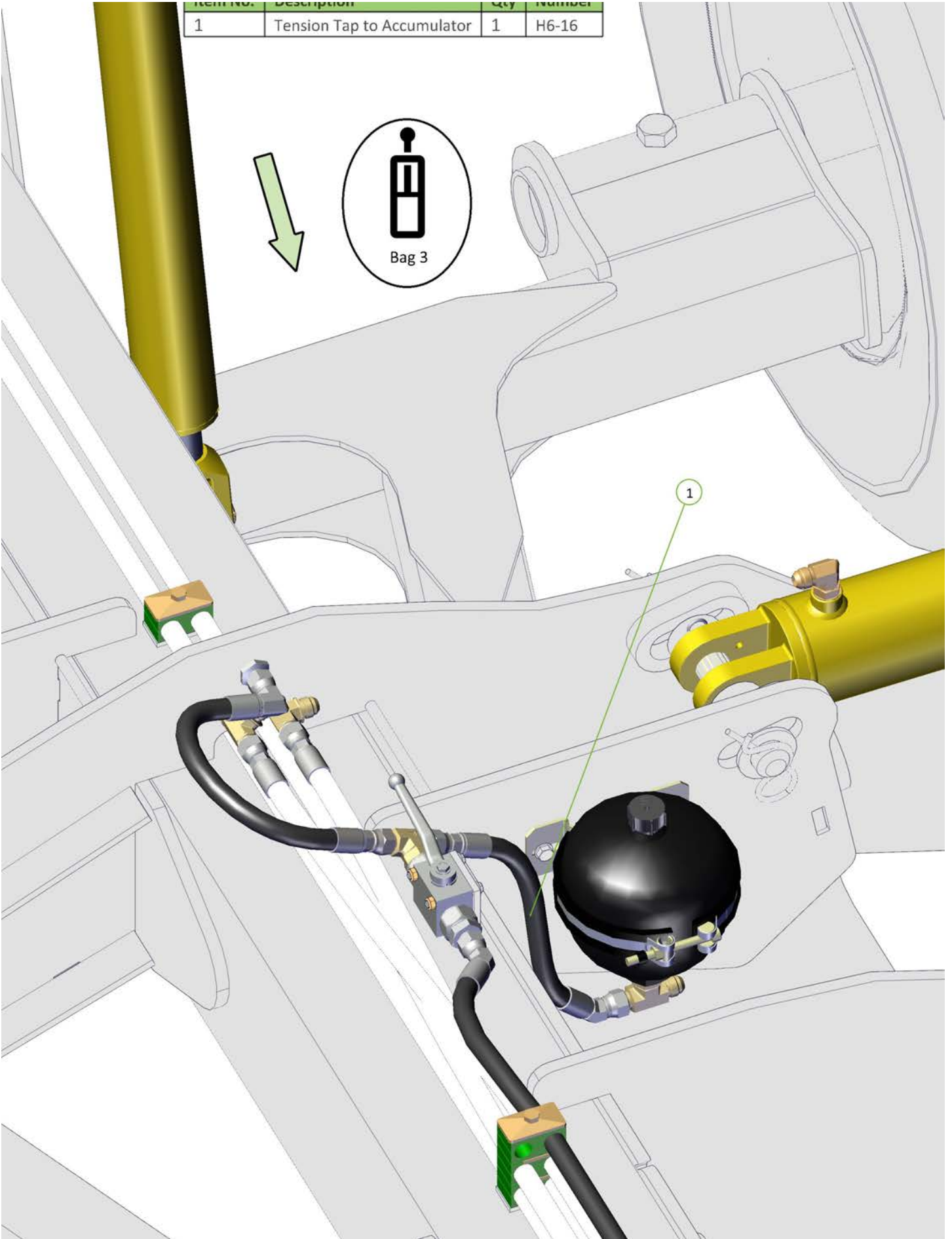
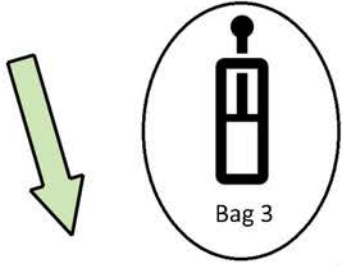

Item No.	Description	Qty	Number
1	Accumulator to LH Tension Cylinder	1	H6-17

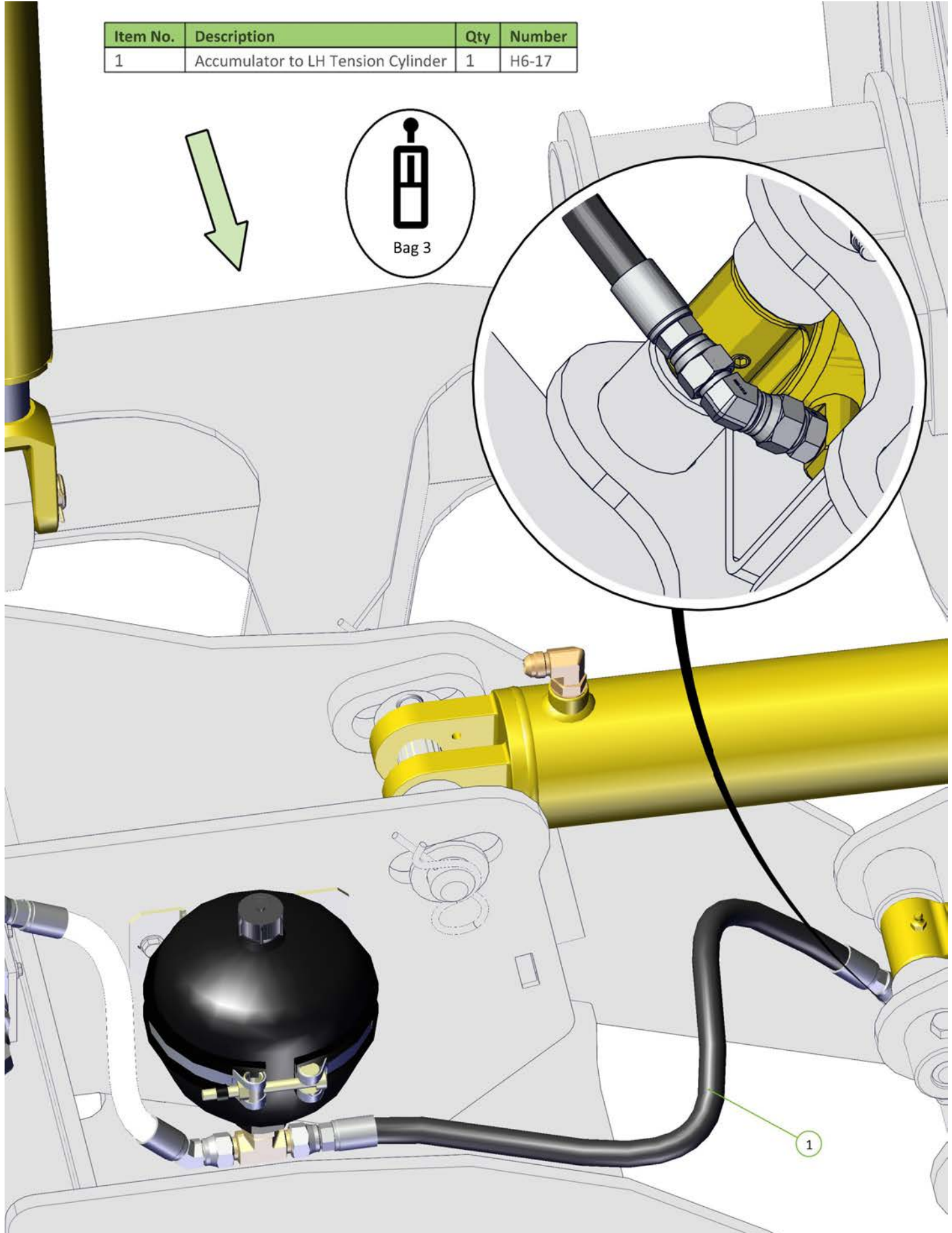
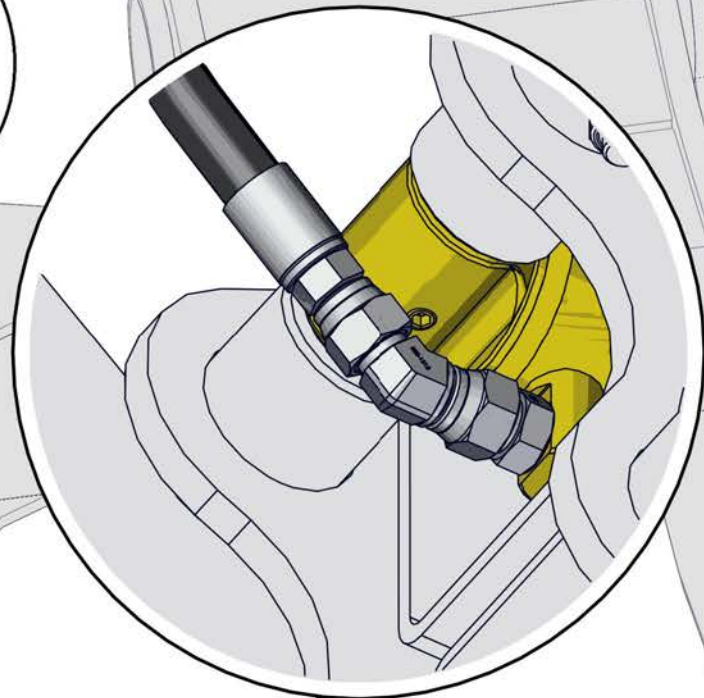
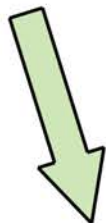

Item No.	Description	Qty	Number
1	Bulkhead to RH Tension Cylinder	1	H6-19
2	JIC Male, JIC Female Swivel, M16 x 2.0 Test Point	1	0325-S159-121216

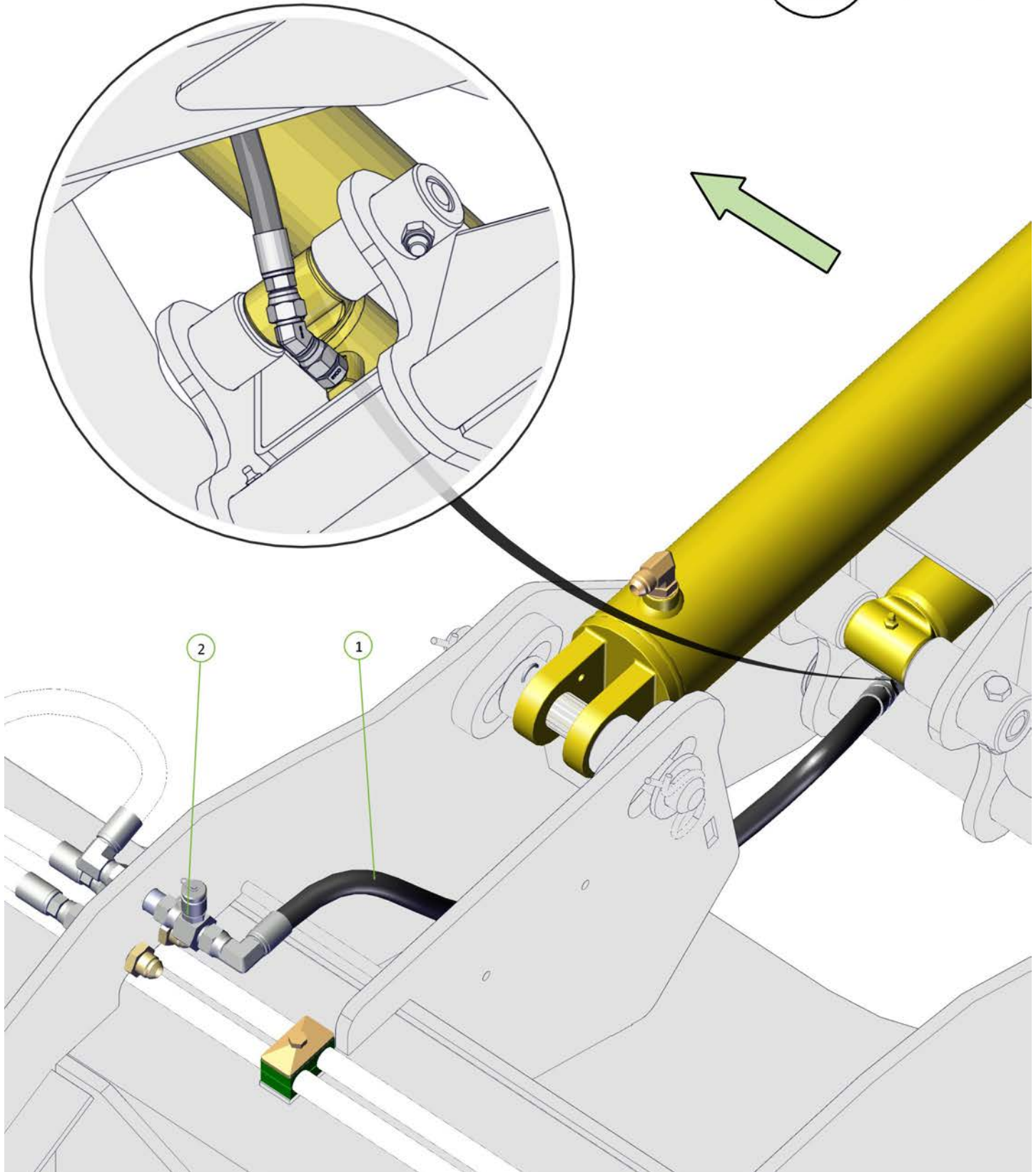

Item No.	Description	Qty	Number
1	JICM JICM JICM TEE	2	0324-S19-121212

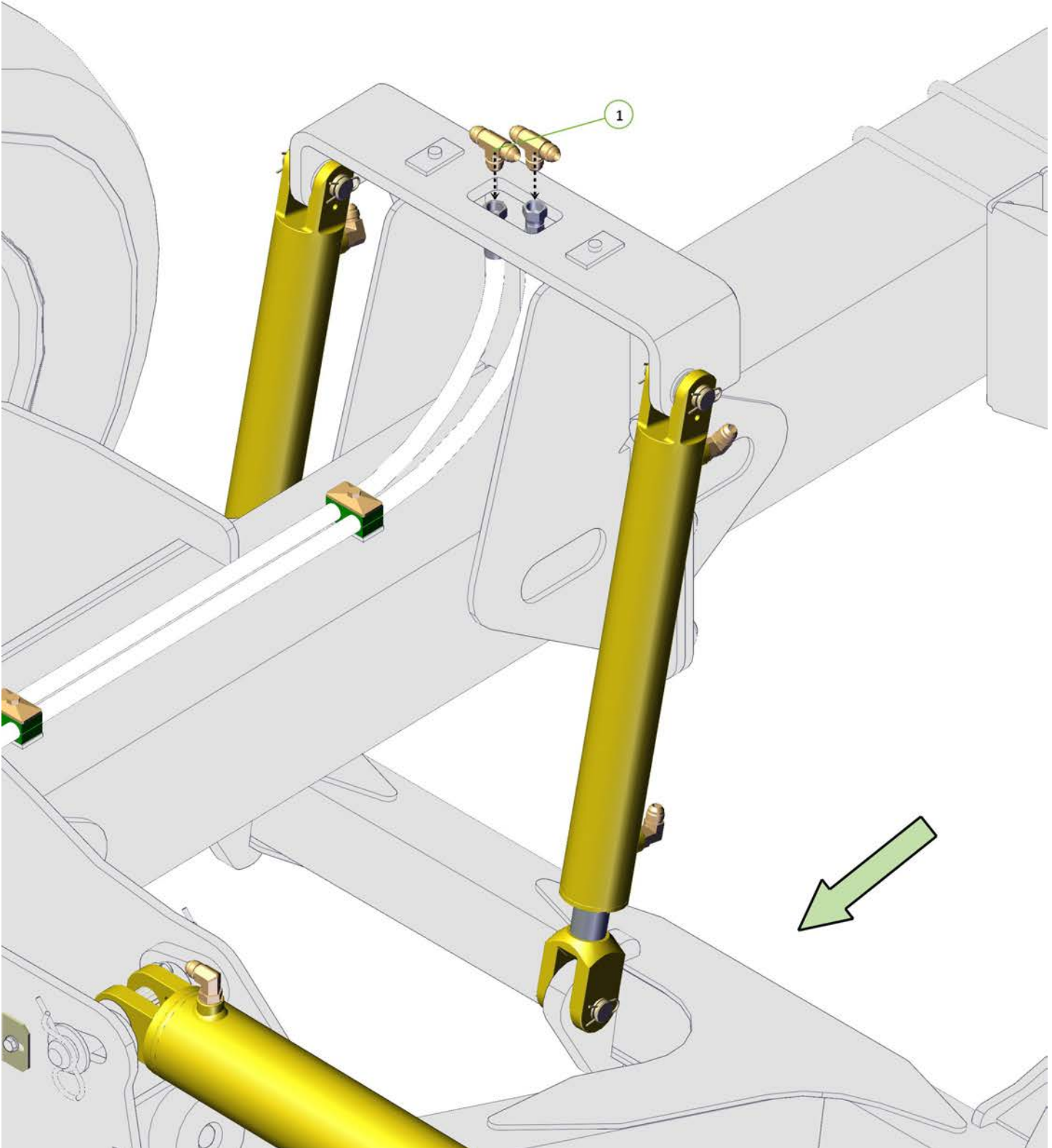

Item No.	Description	Qty	Number
1	Retract Tee to Cylinder Retract	1	H6-14
2	Extend Tee to Cylinder Extend	1	H6-15

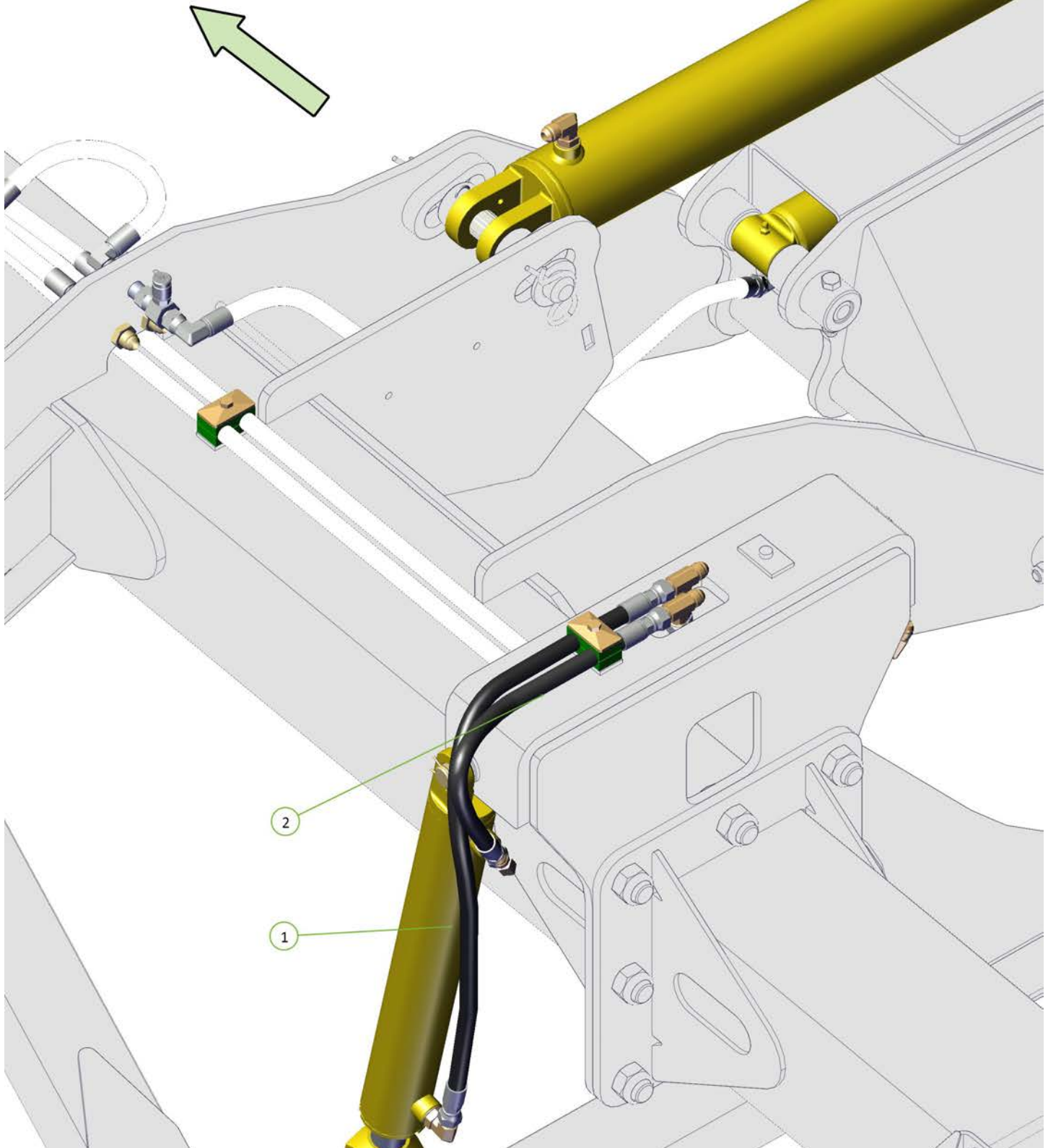

Item No.	Description	Qty	Number
1	Extend Tee to Cylinder Extend	1	H6-15
2	Retract Tee to Cylinder Retract	1	H6-14

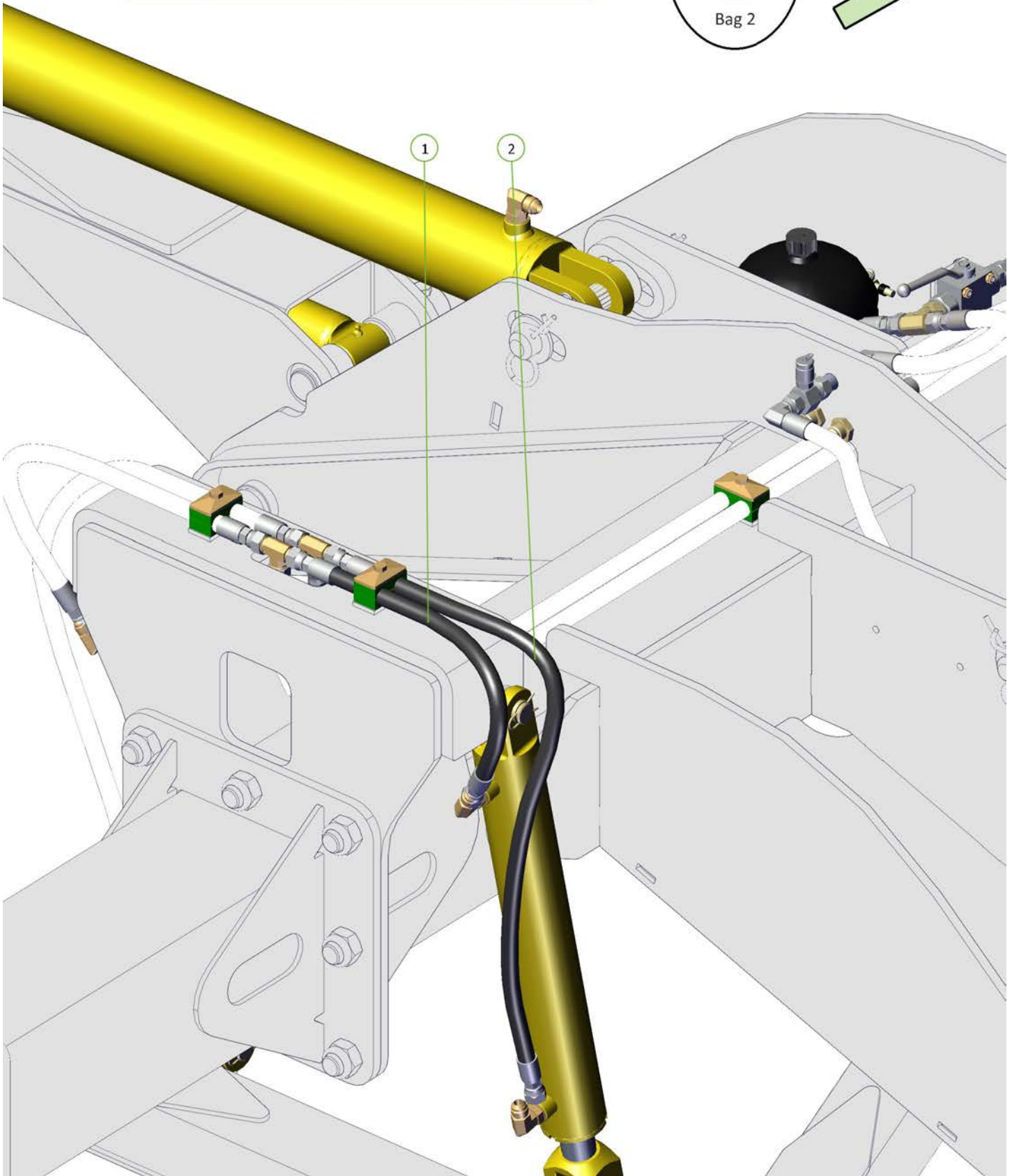
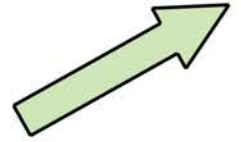

Item No.	Description	Qty	Number
1	Bulkhead to Right Hand Extend Port	1	H6-10
2	Bulkhead to RH Retract Port	1	H6-09

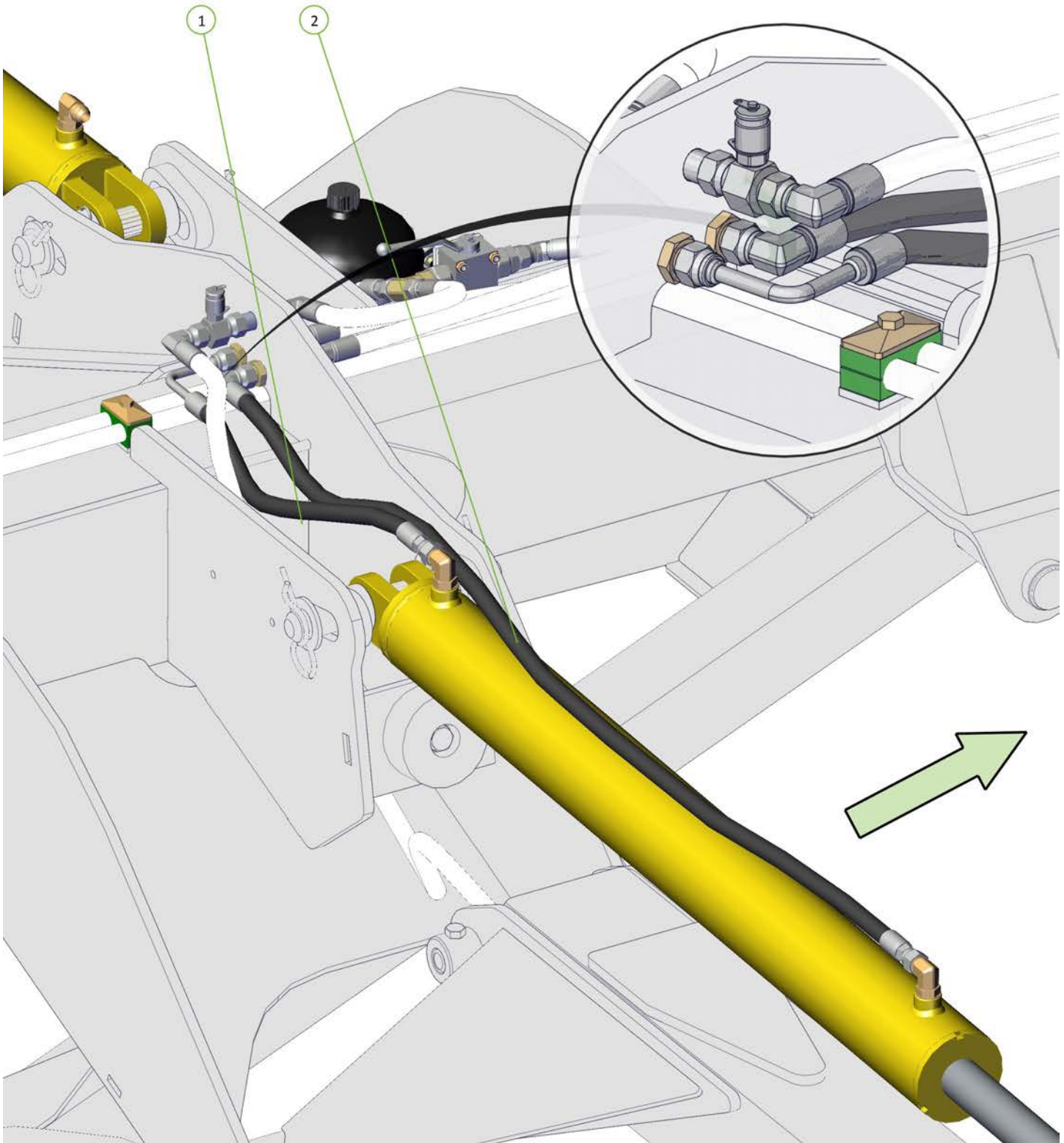

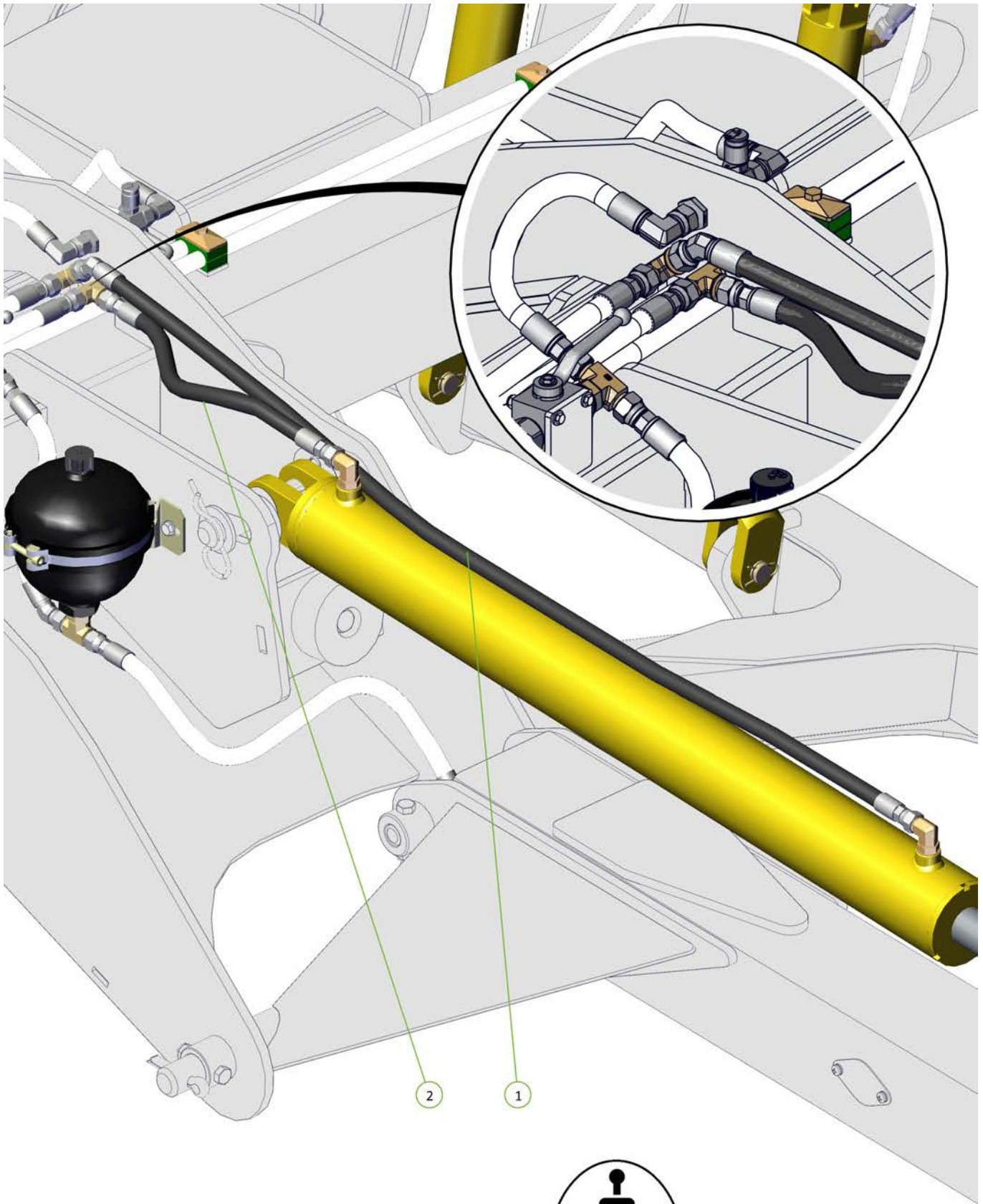

Item No.	Description	Qty	Number
1	Bulkhead to LH Retract Port	1	H6-07
2	Bulkhead to LH Extend Port	1	H6-08

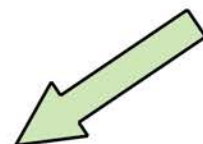

Item No.	Description	Qty	Number
1	100mm Guage	1	0325-GAUGE100-250-G
2	Test Point Adaptor	1	0325-C81-1608

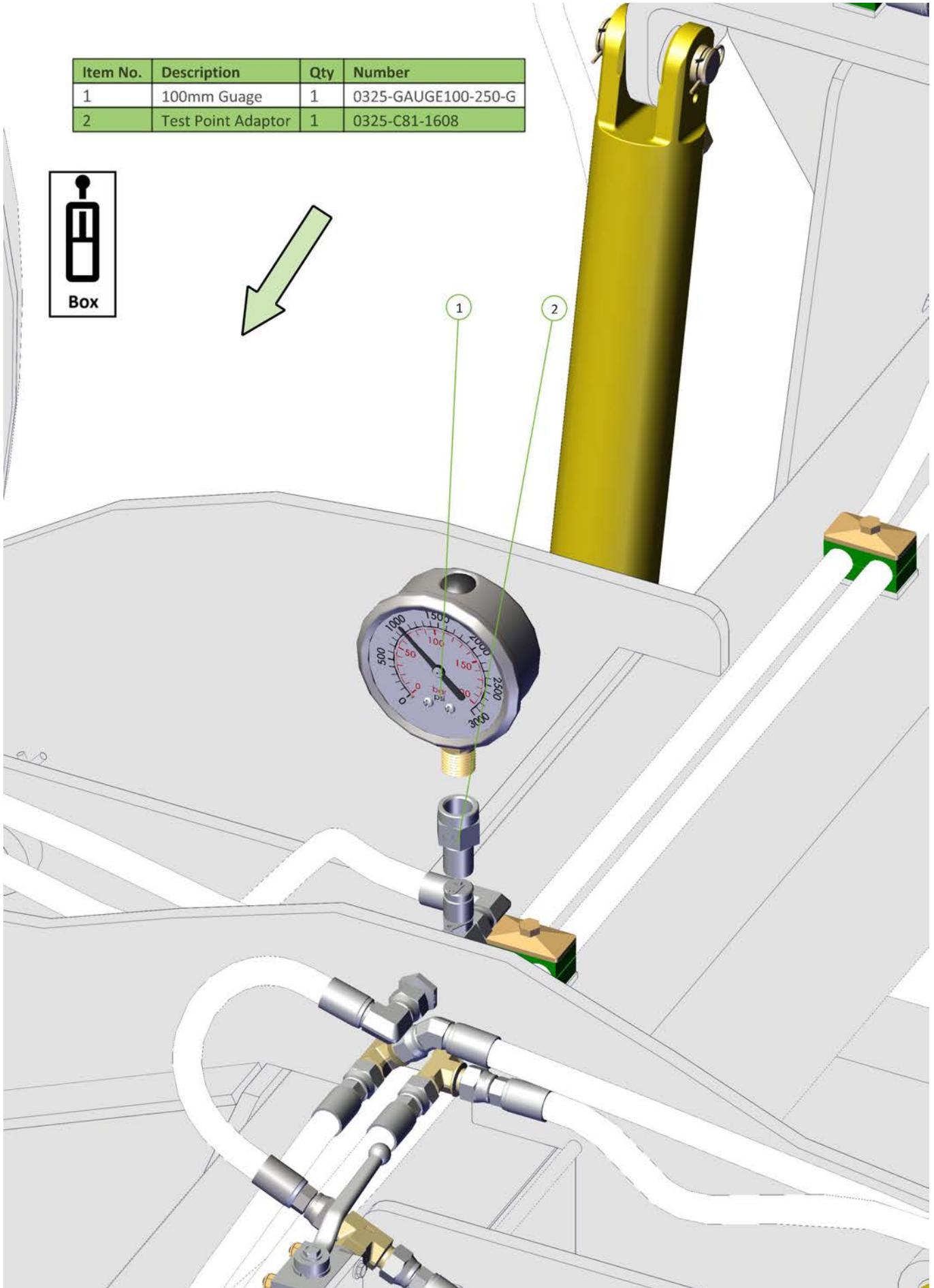

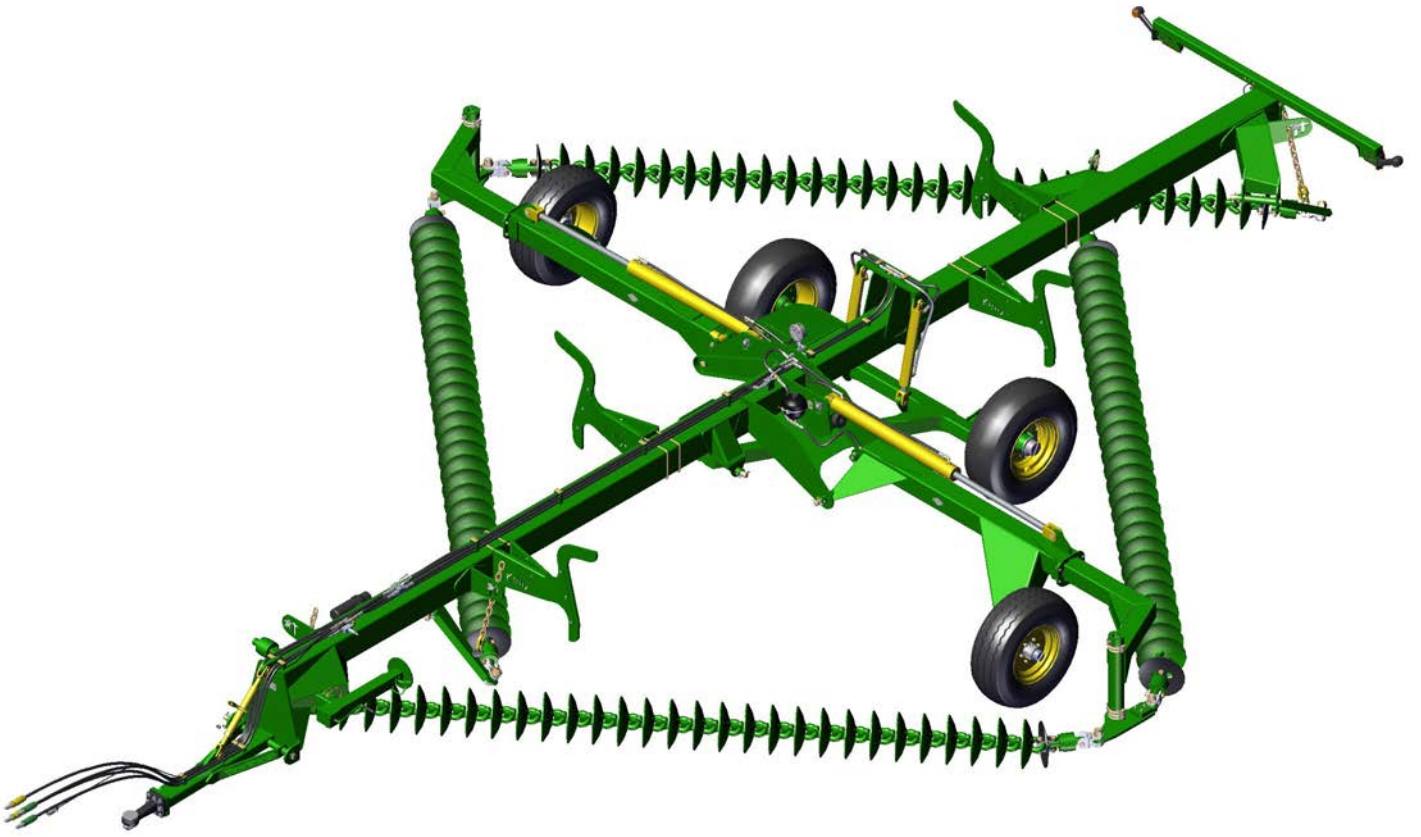

Section 4

Diagrams & Specifications

Rotating seal end of swivel should always face rearward

Fixed housing end of swivel should always face forward

Mounting like this prevents dirt getting forced into the seals of the swivel increasing longevity of the swivel

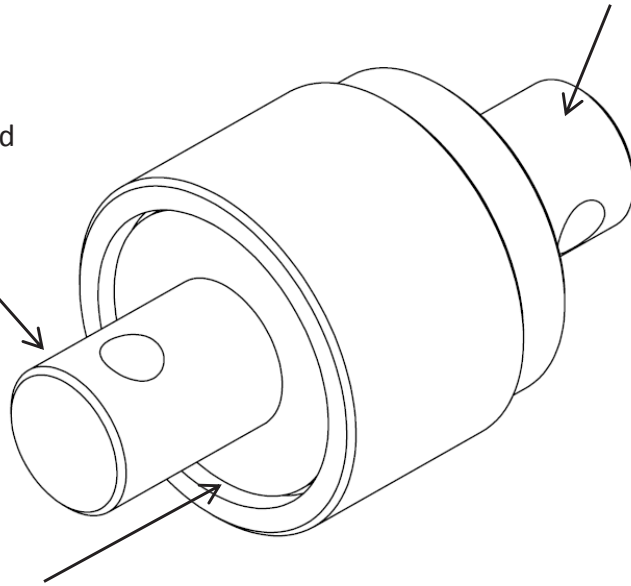

For Example

Swivels attached to the leading ends of the chains should have the rotating seal end attached to the chain like shown

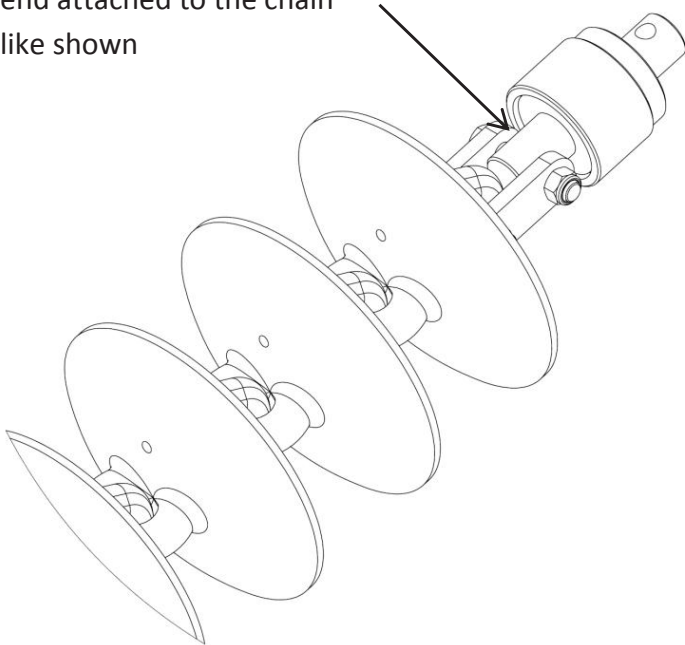

Swivels attached to the trailing ends of the chains should have the fixed housing end attached to the chain like shown

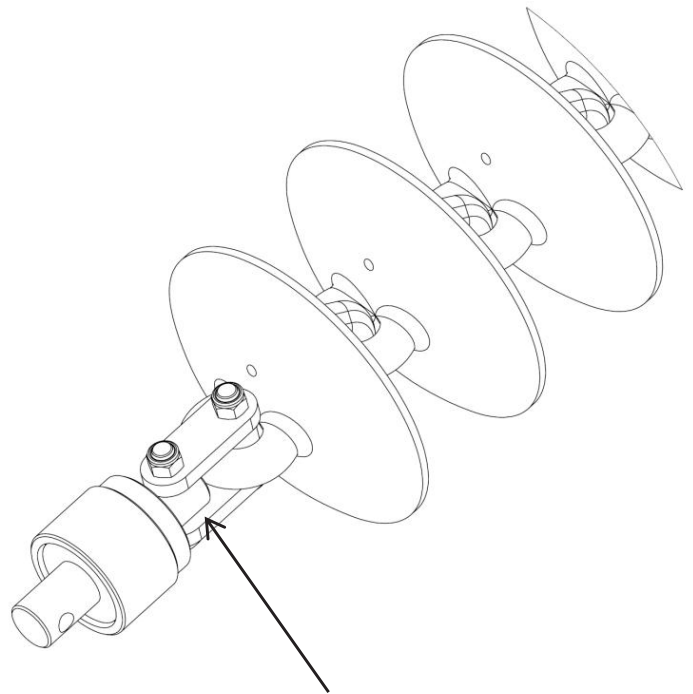

Operating speeds

Operating speeds for normal conditions	
Chain type	Speed
Prickle Chain	6-10 Mph / 10-16 kmph
Disc Chain	6-8 Mph / 10-12 kmph
Transport / towing on roads	15 Mph / 25 kmph

Chain Harrow specifications

Model	6m
Working width	21.5'/6.56m
Transport width	8.1'/2.47m
Transport height	13.2'/4m
Transport length	34.3'/10.44m

Bolt Torque Settings

Bolt Type	Wheel nut				U Bolt			Grade 8.8 Bolt					Grade 10.9 Bolt	
Bolt Size	M18	M20	1/2"	9/16"	M10	M12	M16	M10	M12	M16	M20	M24	M20	M24
Ft lb	255	265	90	100	22	36	55	32	48	140	190	270	300	350
Nm	345	360	125	140	30	50	75	44	65	190	260	370	406	475

[1] When fitting a wheel & tire to a hub, tighten the wheel nuts in rotation to the correct tension. To achieve this choose a wheel nut & tighten, then proceed clockwise to the next wheel nut & tighten & so on until all wheel nuts are tight. Then repeat the procedure to check that all nuts are tight. Do not use impact tools to tighten wheel nuts. For a guide to the correct tension of the wheel nuts please use the appropriate tension for your size wheel nuts from the Bolt Torque Settings table.

Torque values are for dry threads and surfaces however it is permissible to apply a small amount of anti corrosive oil to the threads.

Model		Length	CL2	CL1	W36	R300	SD49	Prickle chain
			CL2 disc chain also requires CL1 disc chain					
6m	Front right	14.9'/4.53m	CL2 - 20 CL1 - 2	27	27	36	36	50
	Front left	15'/4.56m	CL2 - 20 CL1 - 2	27	28	36	36	51
	Rear right	15.1'/4.61m	CL2 - 20 CL1 - 2	27	28	37	37	51
	Rear left	15.2'/4.64m	CL2 - 20 CL1 - 2	28	28	37	37	51



Section 5

Assembly Updates

CL2 Chain Configuration

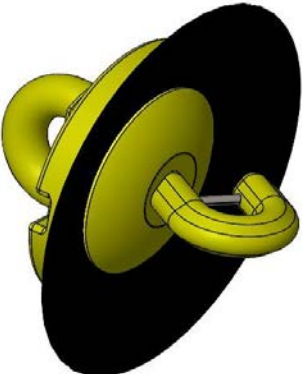

0803-CL2-Link Assembly

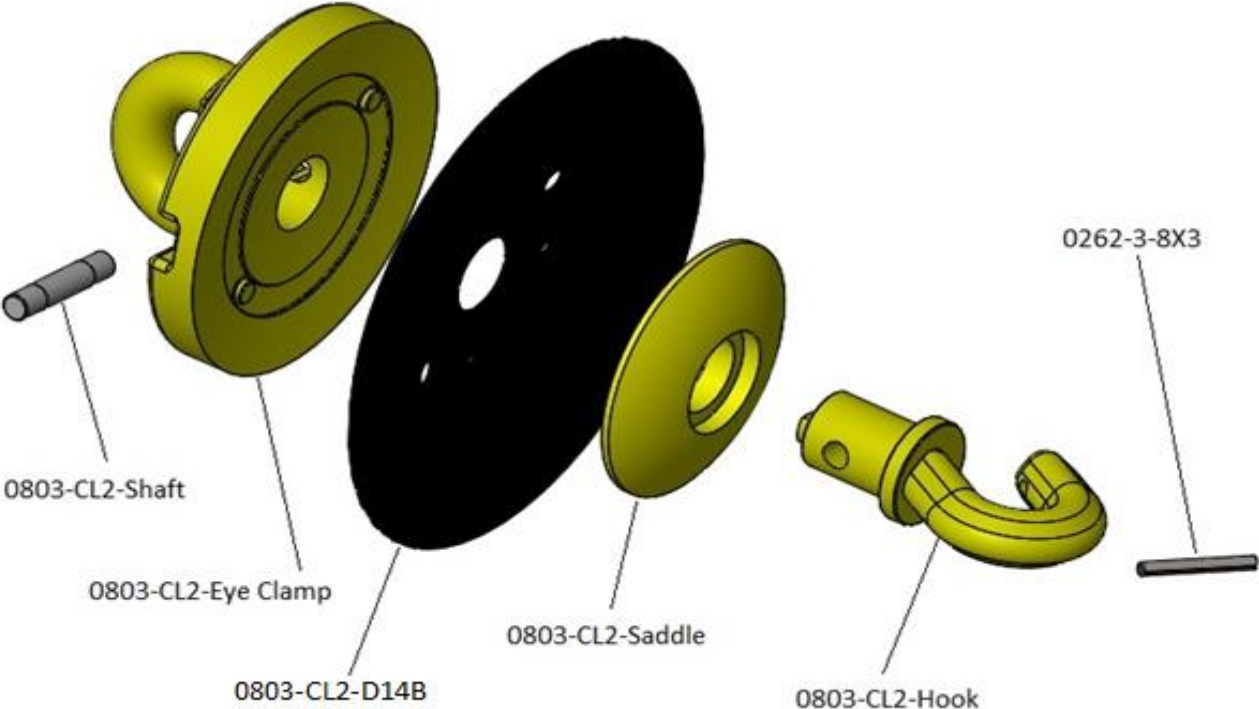

CL2 Disc Change Procedure

This document describes a procedure for the safe changeover of CL2 discs.

NOTE: Each disc weighs 22kg (48lb). Appropriate care must be taken during manual handling

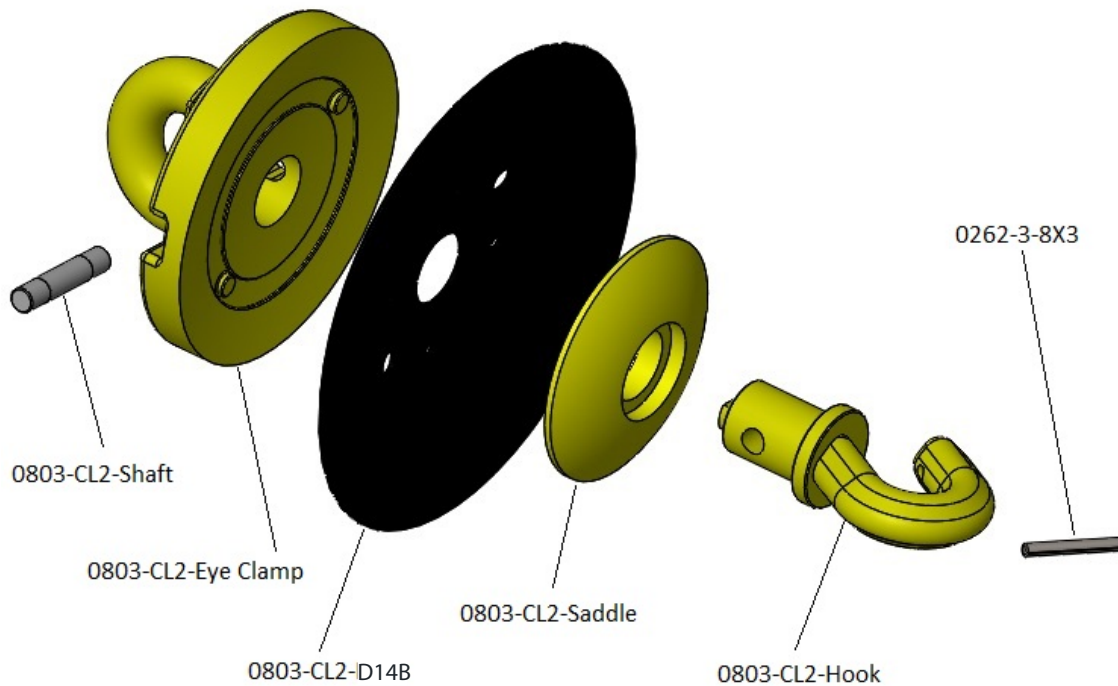

Figure 1: Exploded view of CL2 disc assembly

Changeover procedure as follows:

1. Locate press jig in press (see Figure 2 for orientation).
2. Load disc into press with Hook facing upwards - ensure that Eye Clamp and Hook are secured within the jig with pins supplied
3. Close press, applying force to Saddle (see Figure 3). DO NOT exceed pressure of 9 Tonne (19,800lb)
4. With the clamping force applied, push or tap the shaft with a hammer & drift, and remove from the CL2 Disc assembly
5. Open the press and remove the Disc from the assembly
6. Ensure that all surfaces of the castings are free from debris

CL2 Disc Change Procedure

7. Place replacement disc on to Eye Clamp, ensuring that location holes align with casting lugs
8. Close press and re-apply clamping force. Visually confirm that Hook location hole is properly aligned with Eye Clamp location hole
9. Locate pin within hole and tap gently through both castings
10. Remove clamping force, and remove CL2 assembly from jig
11. CL2 disc is now ready for use. Repeat procedure as necessary

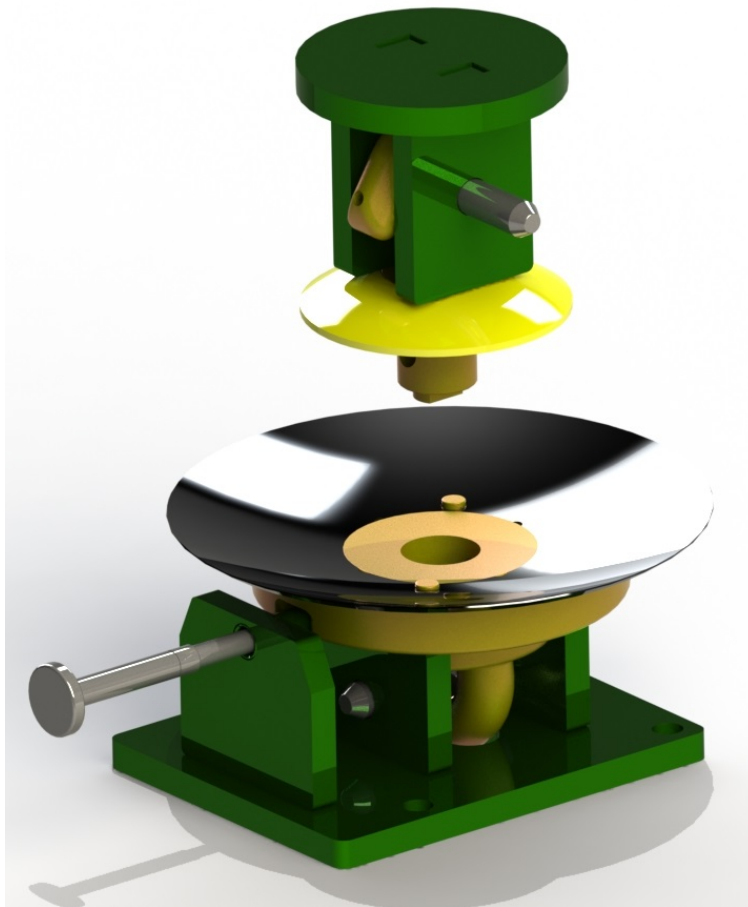

Figure 2: CL2 disc with press jig in Open position

CL2 Disc Change Procedure

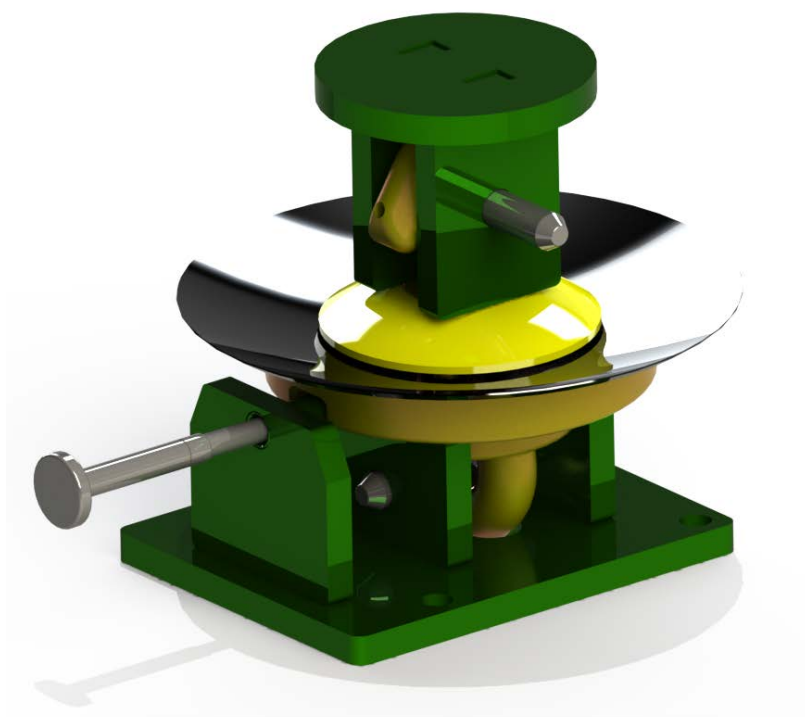

Figure 3: CL2 disc with press jig in Closed position

