



Better Tillage. Better Tomorrow.

Assembly Manual

KELLY TILLAGE SYSTEM 2006

KEASM-G-01012024

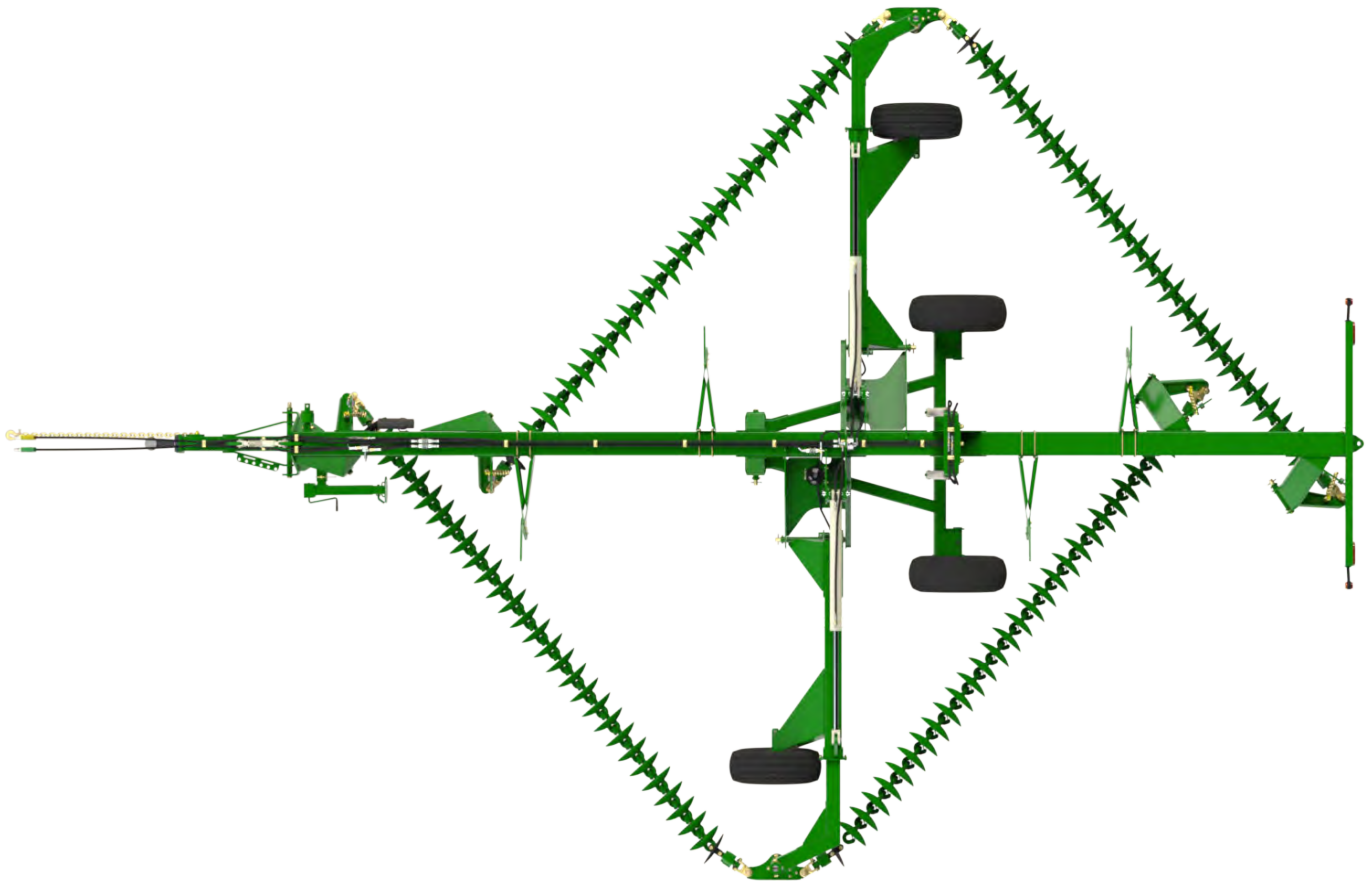

SERIAL NUMBER:



Phone +61 8 8667 2253
Email sales@kellytillage.com
kellytillage.com

Booleroo (Head Office)
684 Kelly Road,
Booleroo Centre SA 5482

Adelaide Office
28 Greenhill Road,
Wayville SA 5034





Thank you for choosing a KELLY product.

We trust that you find the following manual clear and easy to follow. If you should require additional customer support or assistance, please do not hesitate to contact us.

Spare parts can be purchased, as required, through your local dealer or by contacting KELLY directly.

The KELLY team values your feedback. Should you have any difficulties that you wish to raise, suggestions for improvement or modifications that you feel would enhance our products we look forward to hearing from you.

Contact Us

Australia

Booleroo (Head Office)

684 Kelly Road,
Booleroo Centre SA 5482

+61 8 8667 2253

Monday - Friday
8am - 4pm ACDT

Adelaide Office

28 Greenhill Road,
Wayville SA 5034

+61 8 8667 2253

Monday - Friday
8am - 4pm ACDT

Global Locations

Eastern Canada

Leading Edge Equipment
www.leadingedgeequipment.ca

1-519-421-3223

Monday - Friday
8am - 4pm EST

Western Canada

Adair Sales & Marketing Co Inc
www.adairreps.com

1-306-773-0996

Monday - Friday
8am - 5pm CST

United States

Hood & Company

+1 417-865-2100

Monday - Friday
8am - 4pm CST

Europe

kellytillage.com

+61 8 8667 2253

Monday - Friday
8am - 4pm ACDT

Argentina

Giorgi Sa Maquinarias Agricolas
www.giorgi.com.ar

+54 3464 493512

Monday - Friday
8am - 5pm ART

South Africa

Desmond Whitfield CC

+27 82 567 8245

Monday - Friday
8am - 4pm SAST

Contents

Section 1 - Unpacking	4
Section 2 - Assembly	6
Section 3 - Light Kit	53
Section 4 - Hydraulics	57
Section 5 - Decal application	89
Section 6 - Chain Assembly	103
Section 7 - Specifications	110
Notes	113

Legend



This symbol indicates which bag the relevant fasteners are in.



This symbol indicates which bag the relevant hydraulics are in.



This symbol indicates the hydraulics are in a box.



This symbol indicates which way the machine is travelling.



Section 1 - Unpacking

We recommend the use of suitable lifting equipment with a lifting capacity of at least 4 tones.



Before unloading any loads please inspect exterior for damage.



CAUTION

Take care when opening doors as load may have shifted or restraints may have broken.

- Remove boxes from doorway of container one at a time using a forklift truck. Each box weighs approximately (5512 lbs / 2500kg)
- Check strapping on each bundle before attempting to remove
- Attach chains to the packing frame using shackles and using suitable equipment (eg. forklift or tractor) drag framework bundles out of container. To move bundles away from front of container lift from side with forklift. Do not lift under angle iron frame, lift only under centre frame. Each bundle weighs approximately 7000 lb (3200 kg).

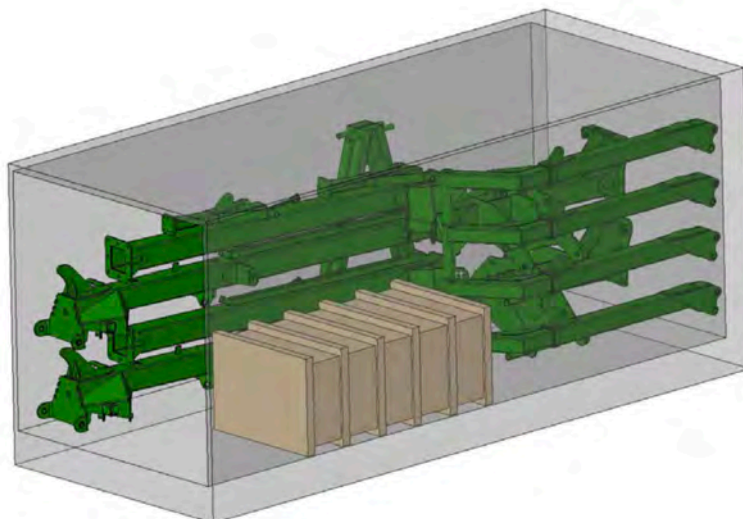

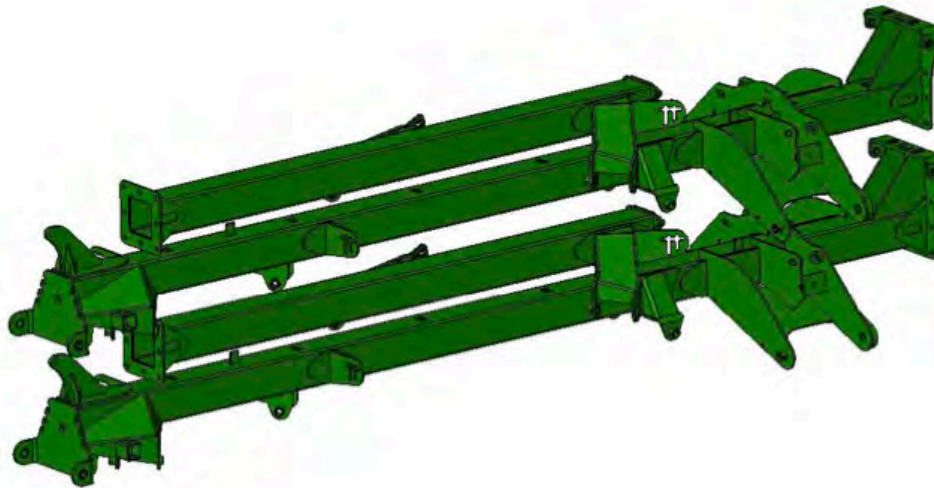

CAUTION

Before cutting straps attach slings or chains and take the weight of the frames to avoid them slipping or falling and causing injury.



CAUTION

Wear eye and hand protection when cutting straps. Sharp edges are exposed as straps separate and may cause injury.



CAUTION

To avoid falling or moving components, before cutting straps attach slings or chains to individual pieces and only cut the straps holding the piece to be lifted.

- Remove boxes from rear of container one at a time using a forklift truck. Each box weighs approximately 5512 lbs (2500 kg)
- Cut straps holding bundles and separate parts and place in assembly area
- Once all parts have been identified, the machine is ready for assembly
- Identify parts for each machine by serial no. or description and separate. Open parts box and check that all parts are accounted for against checklist
- Read assembly instructions before proceeding.

KELLY

Section 2 - Assembly

Item No.	Description	Qty	Number
1	M24 x 65 Class 8.8 ZP Bolt	11	0211-2465
2	Nyloc Nut M24	11	0221-NYL24
3	6m Rear Section Frame	1	1520-03
4	Centre Section Frame	1	1520-01
5	Washer Flat M24	22	0231-F24

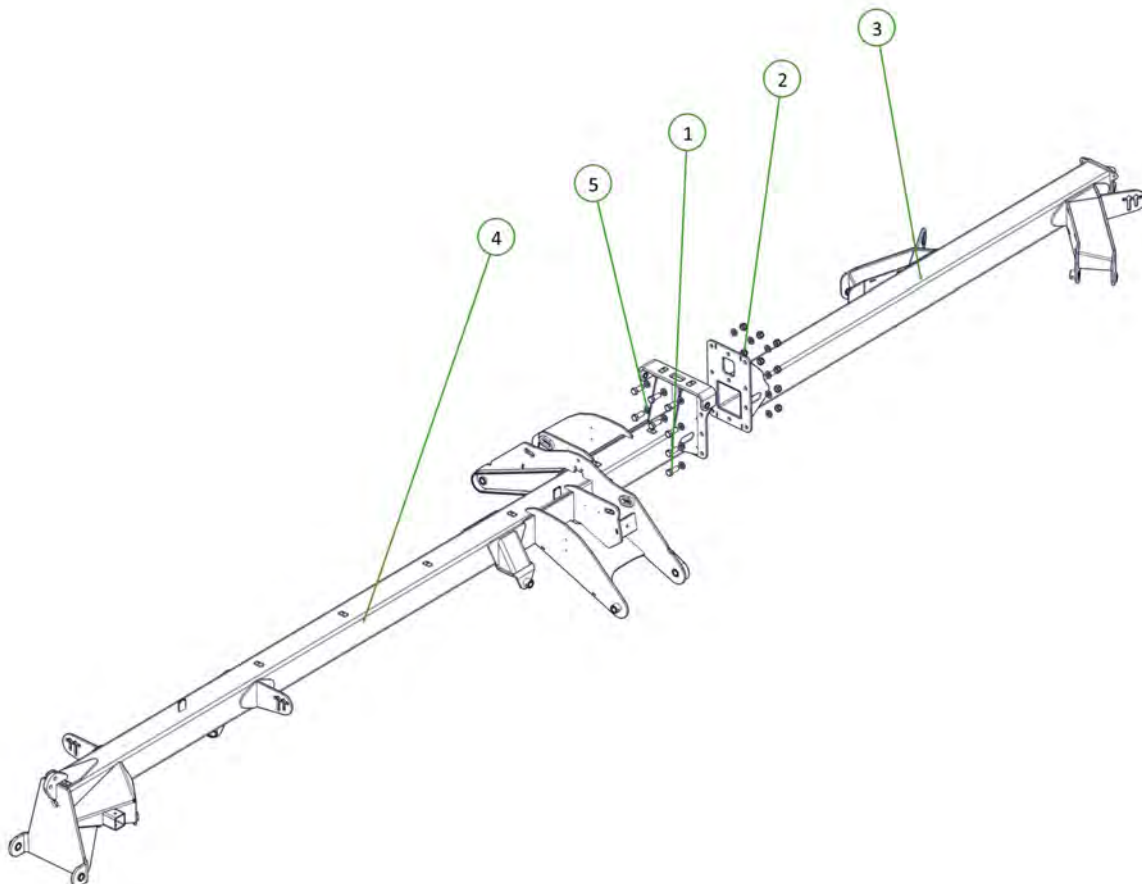

Item No.	Description	Qty	Number
1	6m Wheel Arm Frame	1	1520-10
2	35 ID x 50mm DU Bush	2	0113-MB3550DU

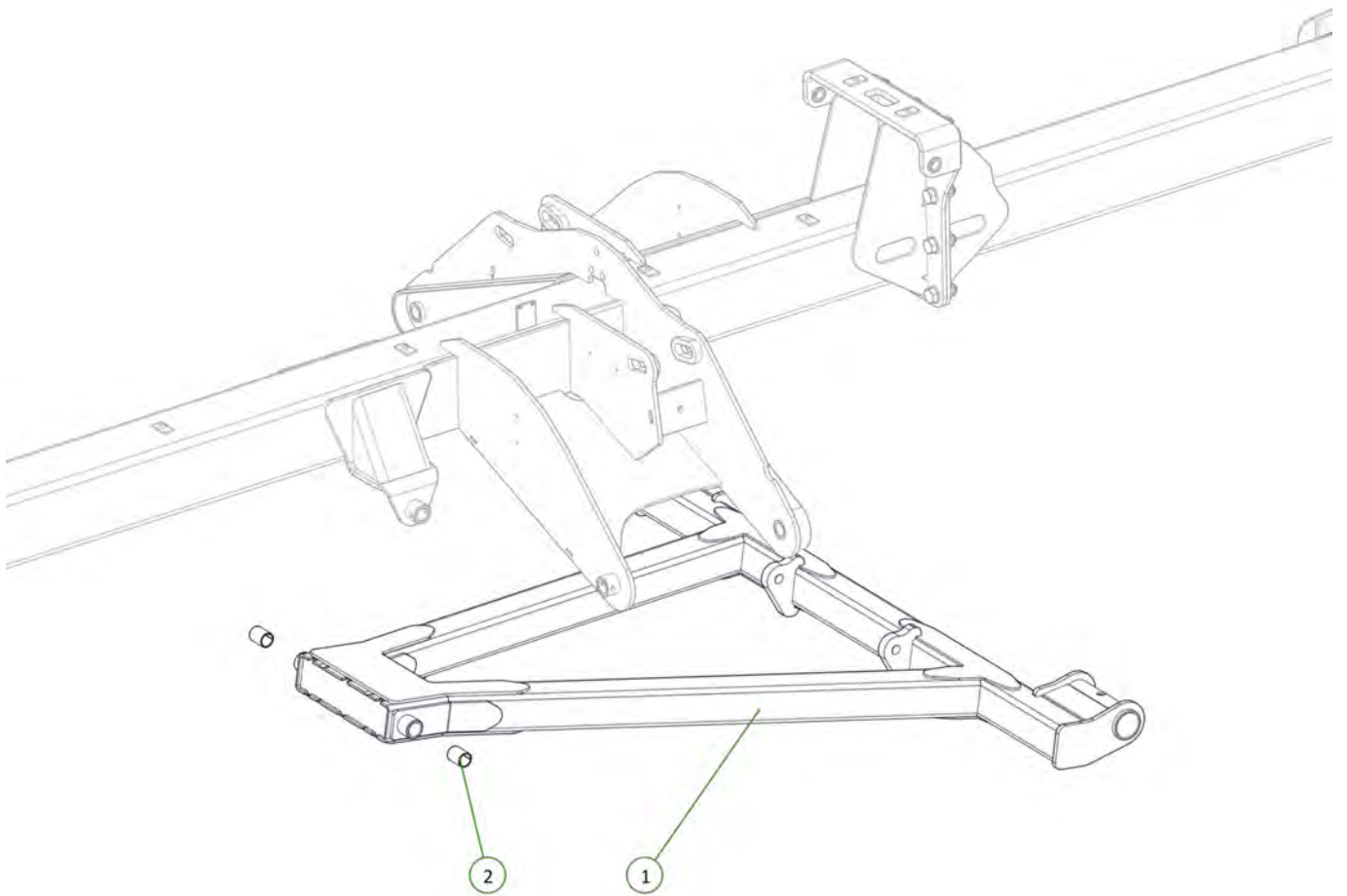

Item No.	Description	Qty	Number
1	M12 x 80 Class 8.8 ZP Bolt	1	0211-1280
2	Nyloc Nut M12	1	0221-NYL12
3	COTTER PIN M13 X 63mm	1	0261-PINC1363
4	Long Pivot Pin	1	1501-35615

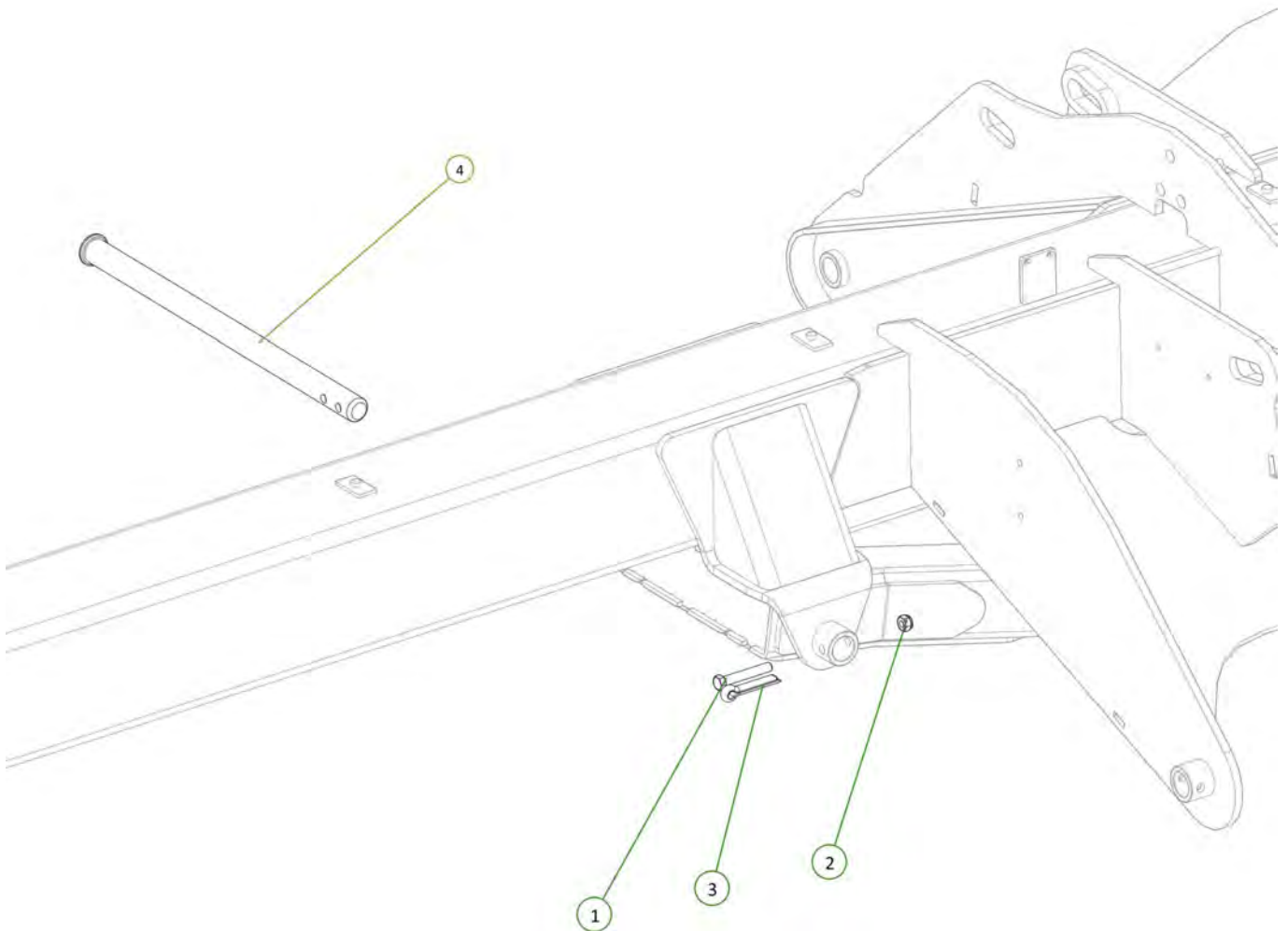

Item No.	Description	Qty	Number
1	M20 x 110 Class 8.8 ZP Bolt	2	0211-20110
2	Nyloc Nut M20	2	0221-NYL20
3	2.75"R C/W 6 tonne 8 on 8" PCD Complete Assembly	2	0733-SH27596880

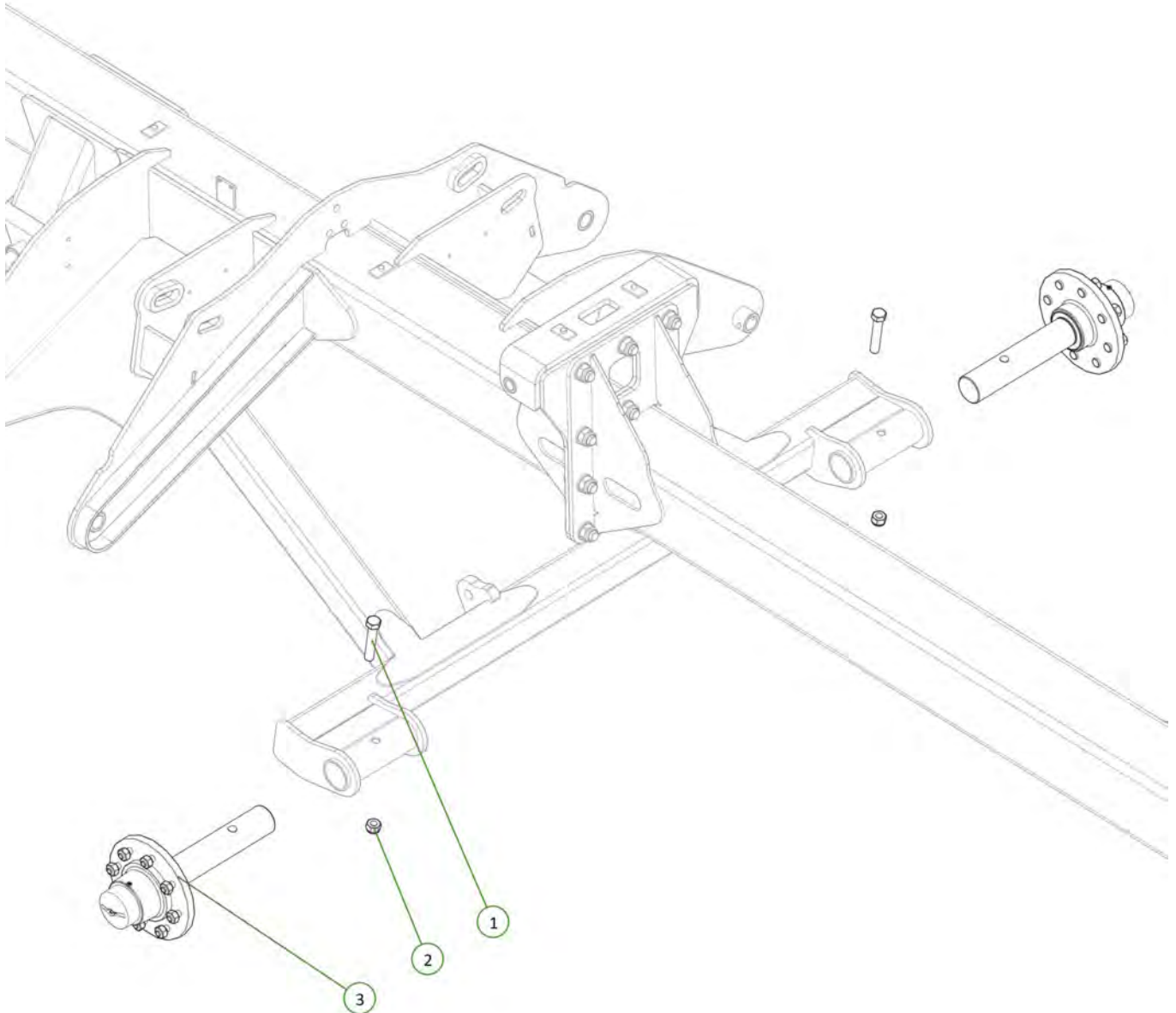
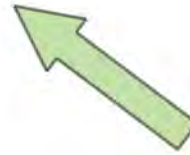

Item No.	Description	Qty	Number
1	11.5/80-15.3 tyre, 9" rim 0 offset, 8 on 8" studs, 162 cntr	2	0711-11.5-80-15.3

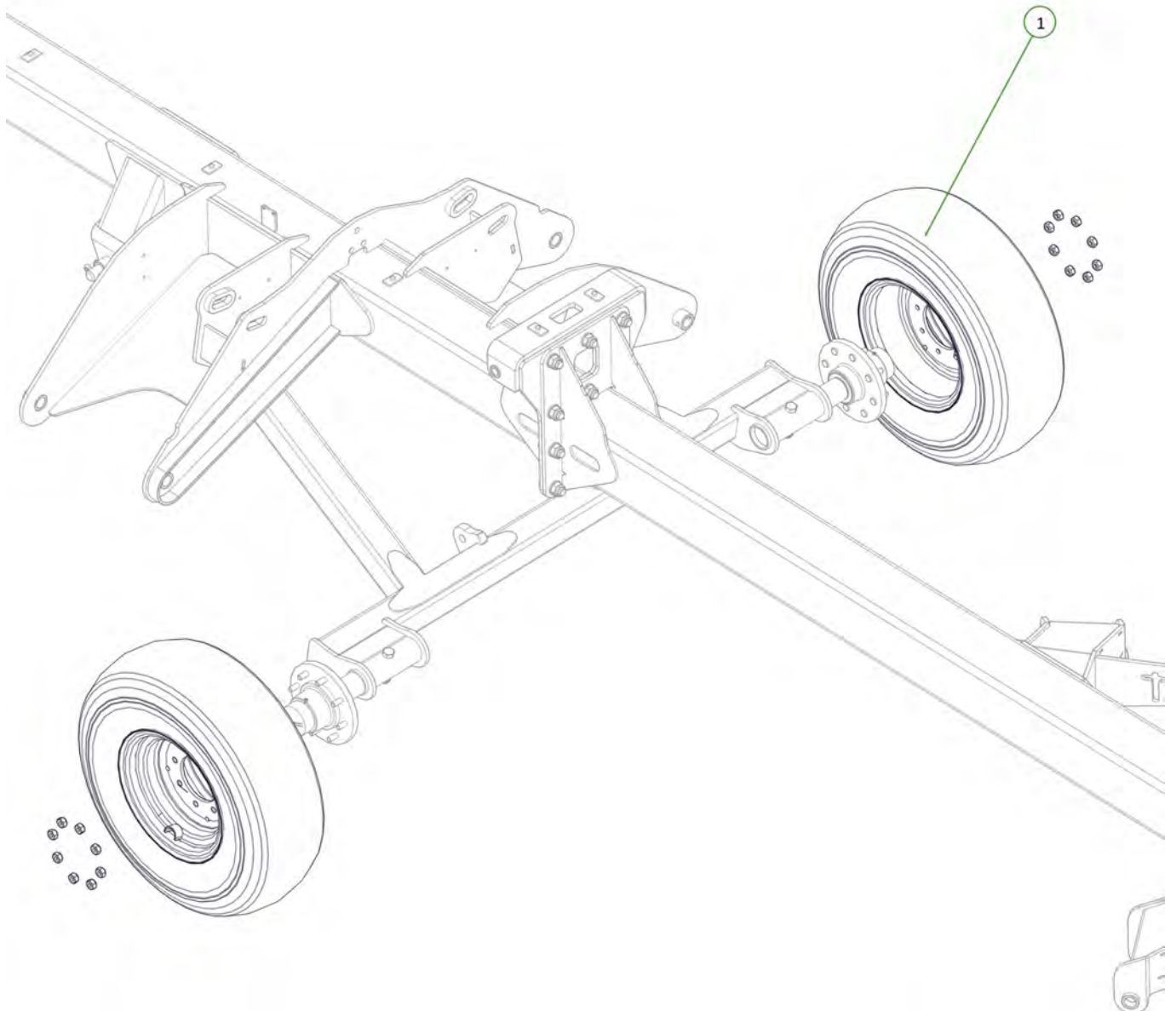

Item No.	Description	Qty	Number
1	2.5" Bore x 16" Stroke Hydraulic Cylinder	2	0311-2516

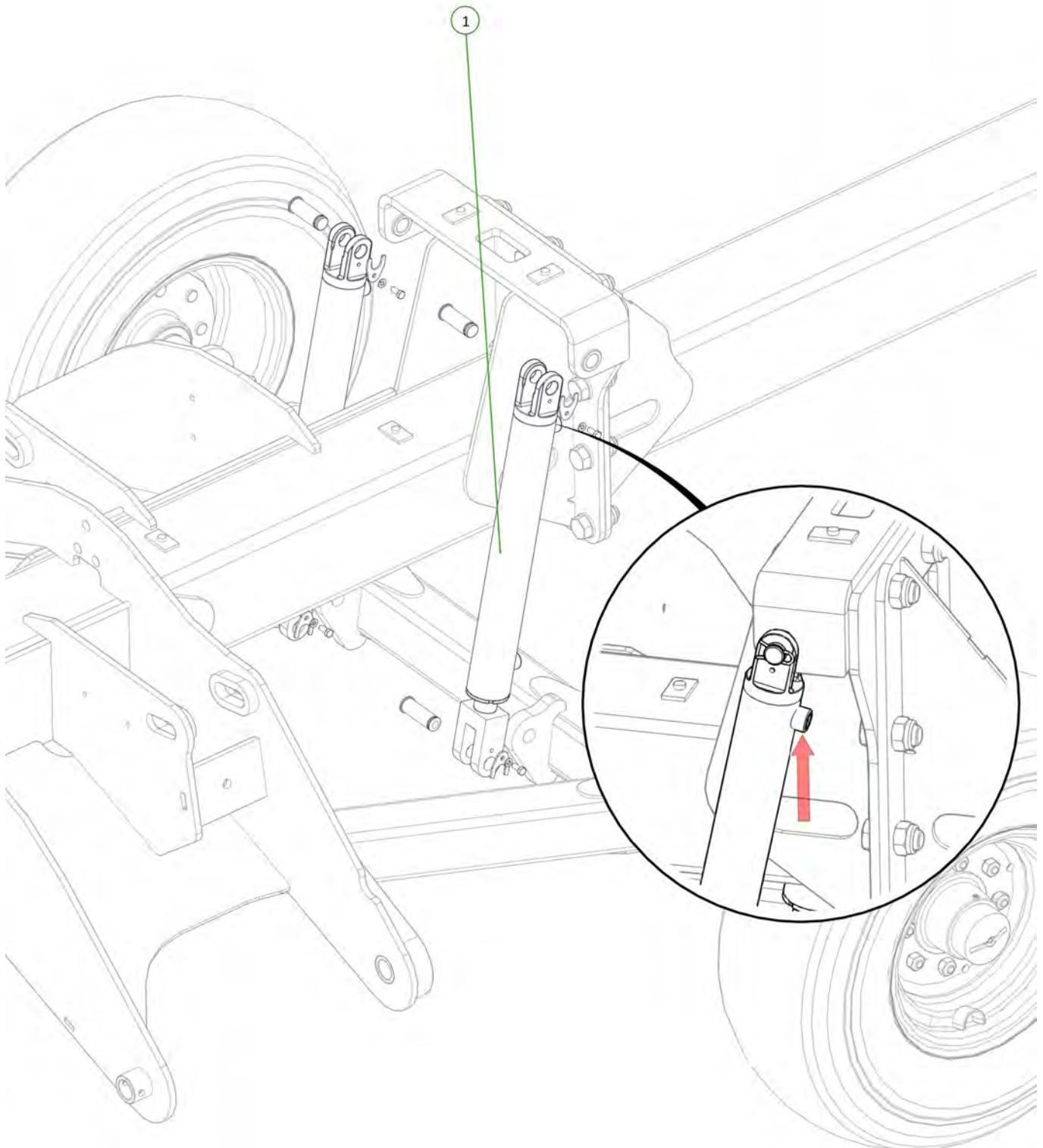
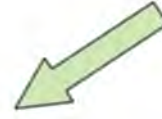

Item No.	Description	Qty	Number
1	6m Inner Wing Frame	1	1520-04
2	6m RH Outer Wing Frame	1	1520-06
3	2" Bore x 20" Stroke 1.75" Rod Single Acting Displacement Cylinder	1	0311-220SADC
4	6m Inner Bearing Pad	8	1501-IBP
5	TEK Phillips Wafer Head Metal Screw 10g x 16mm	40	0241-TEKWH16
6	Circlip Internal 26mm	2	0171-26
7	Wing Tension Pin 2	1	1501-25118

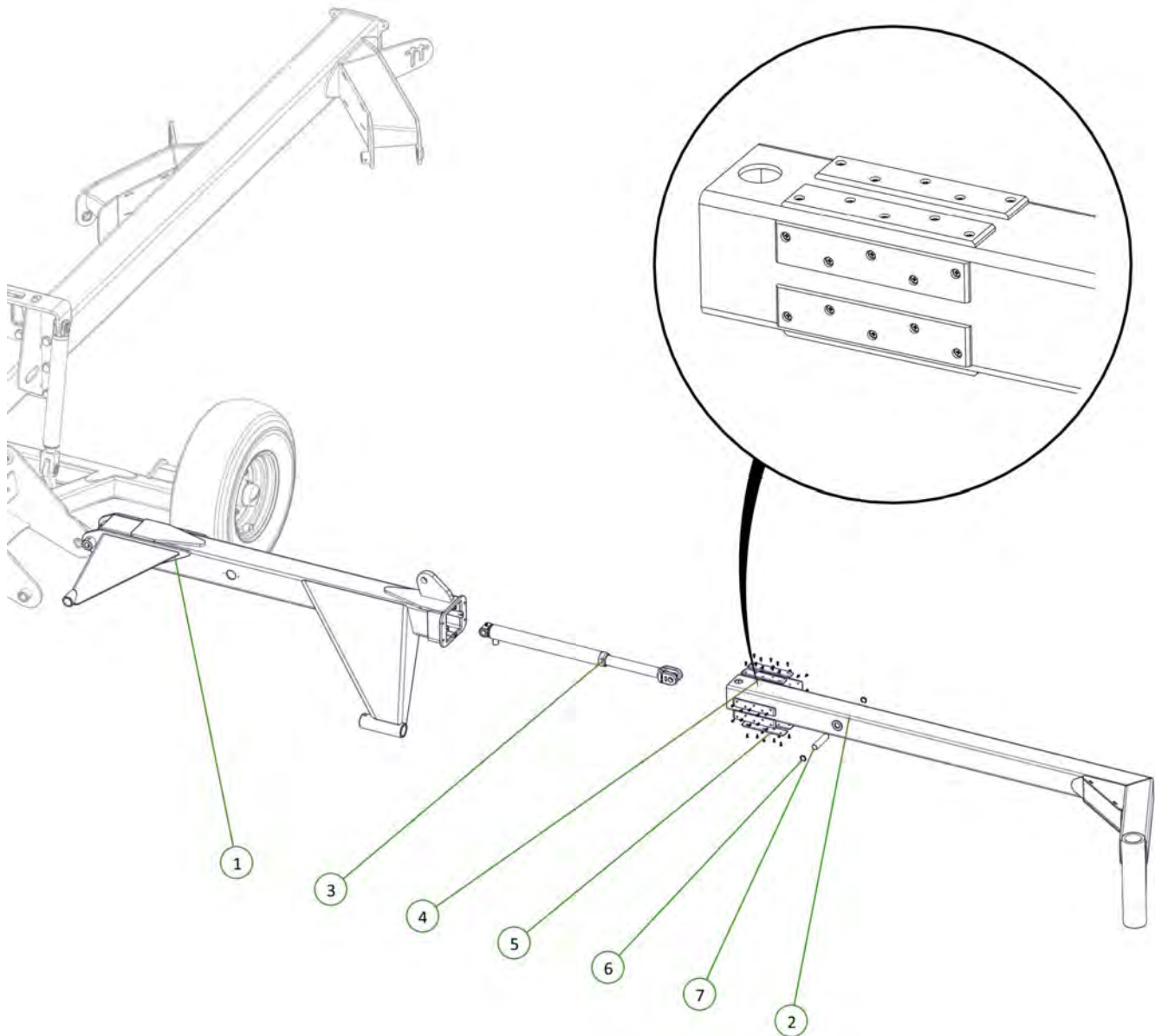

Item No.	Description	Qty	Number
1	6m Outer Bearing Pad	8	1501-OBP
2	Inner Wing Wear Pad Retainer	2	1500-289
3	M12 x 40 Class 8.8 ZP Bolt	4	0211-1240
4	Nyloc Nut M12	4	0221-NYL12
5	Washer Flat M12	8	0231-F12

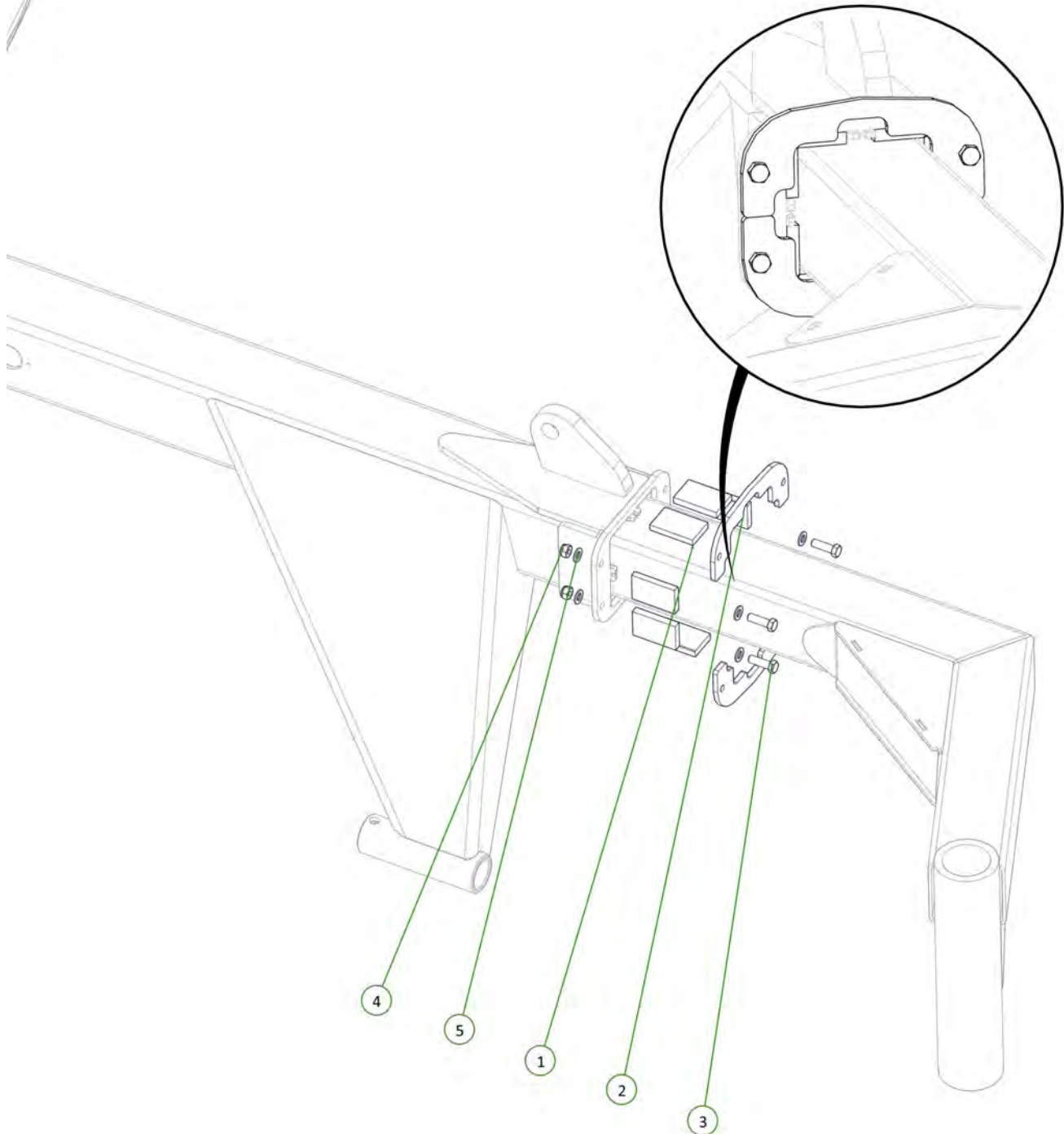

Item No.	Description	Qty	Number
1	6m Pin Access Cap	2	1500-300
2	M6 x 12mm Pan Pozzi Trilobular T/F Screw Zinc	4	0211-M612-92064151
3	Washer Flat M6	4	0231-F6
4	Washer Spring M6	4	0231-S6

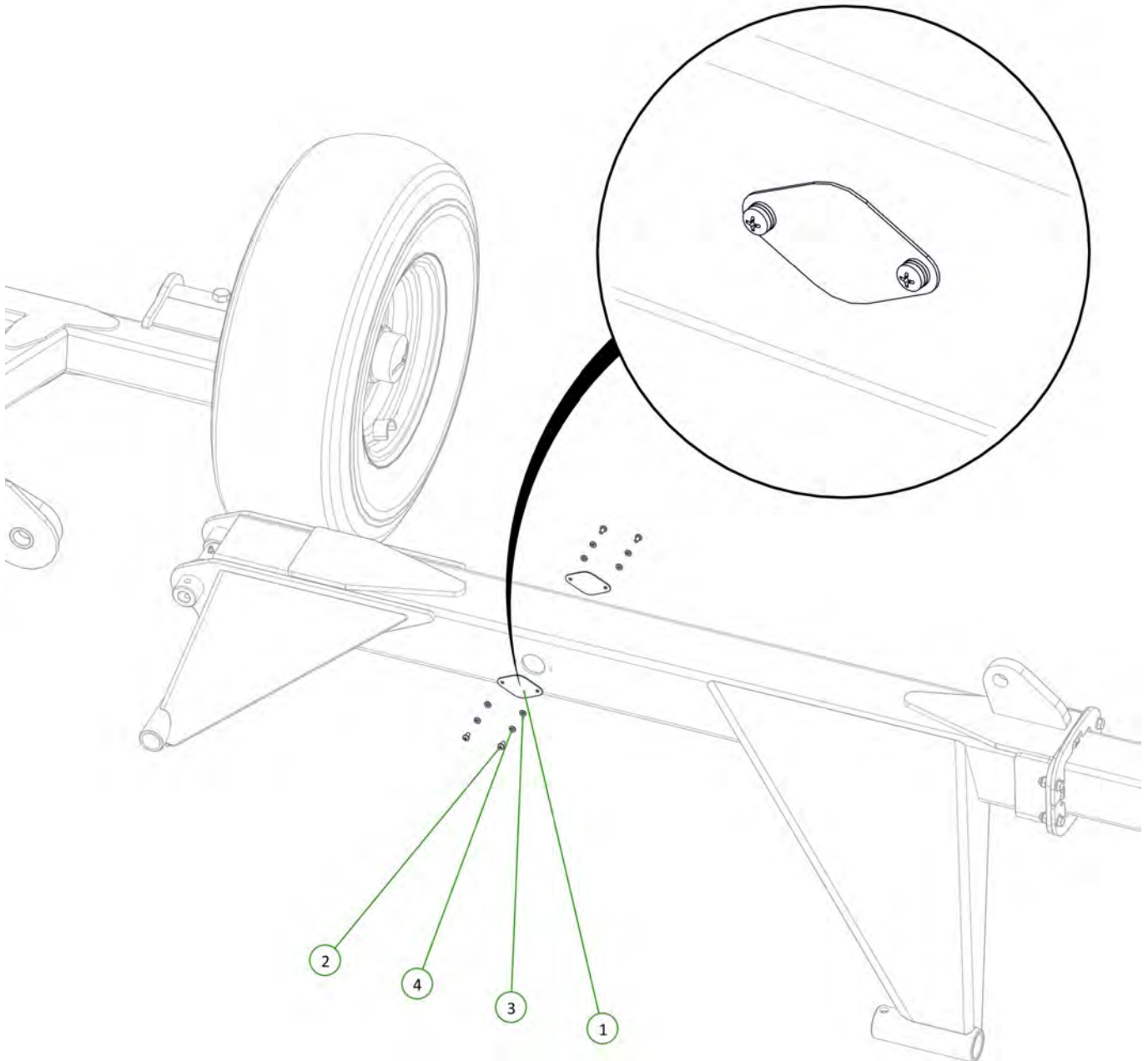

Item No.	Description	Qty	Number
1	Wing Tension Pin	1	1501-25214
2	35 ID x 50mm DU Bush	2	0113-MB3550DU
3	Nyloc Nut M12	1	0221-NYL12
4	M12 x 80 Class 8.8 ZP Bolt	1	0211-1280

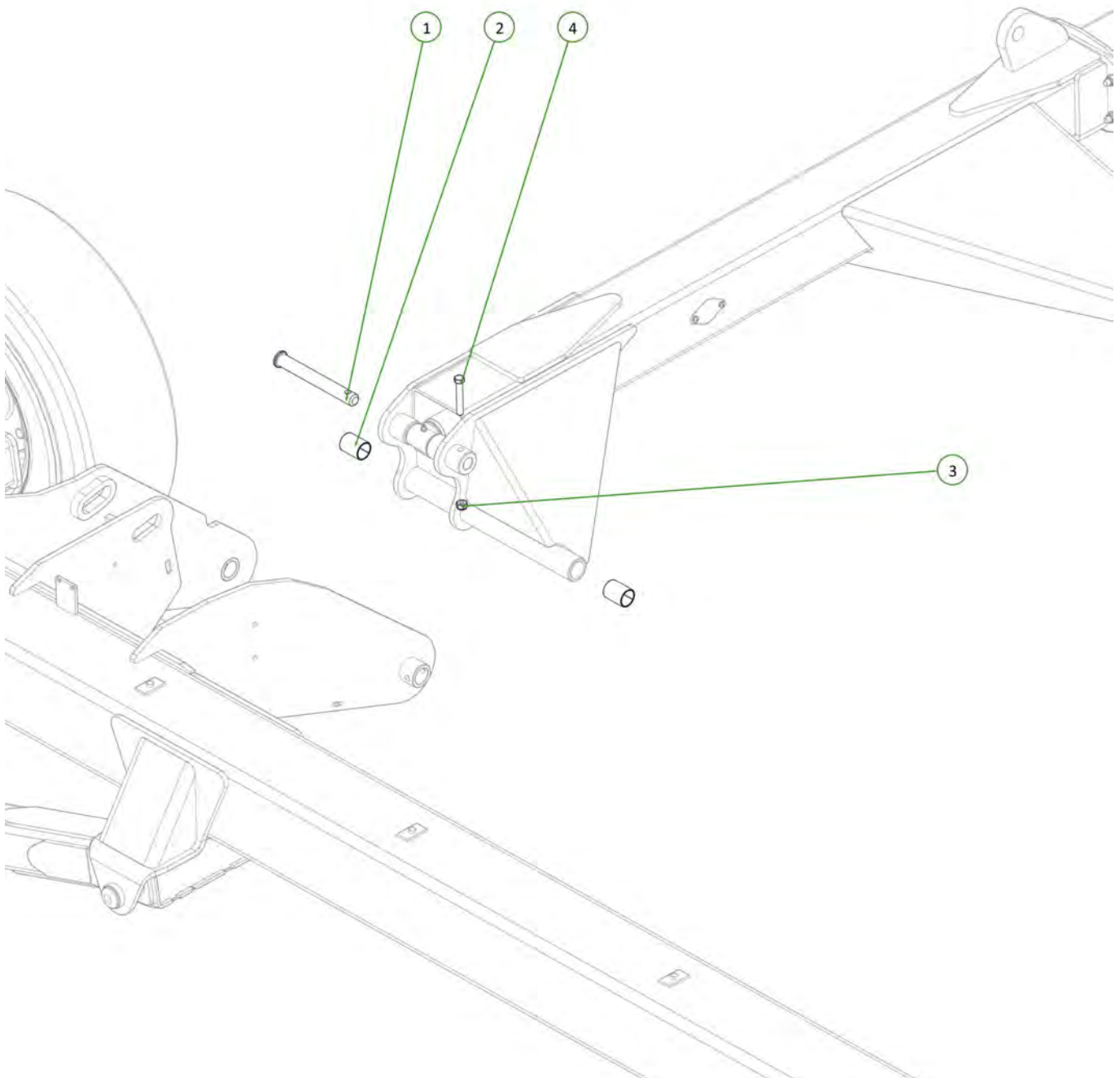
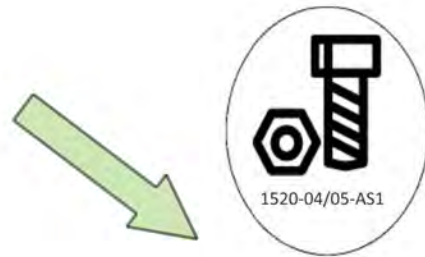

Item No.	Description	Qty	Number
1	M12 x 80 Class 8.8 ZP Bolt	1	0211-1280
2	Nyloc Nut M12	1	0221-NYL12
3	Cotter Pin M13 x 63	1	0261-PINC1363
4	Long Pivot Pin	1	1501-35615

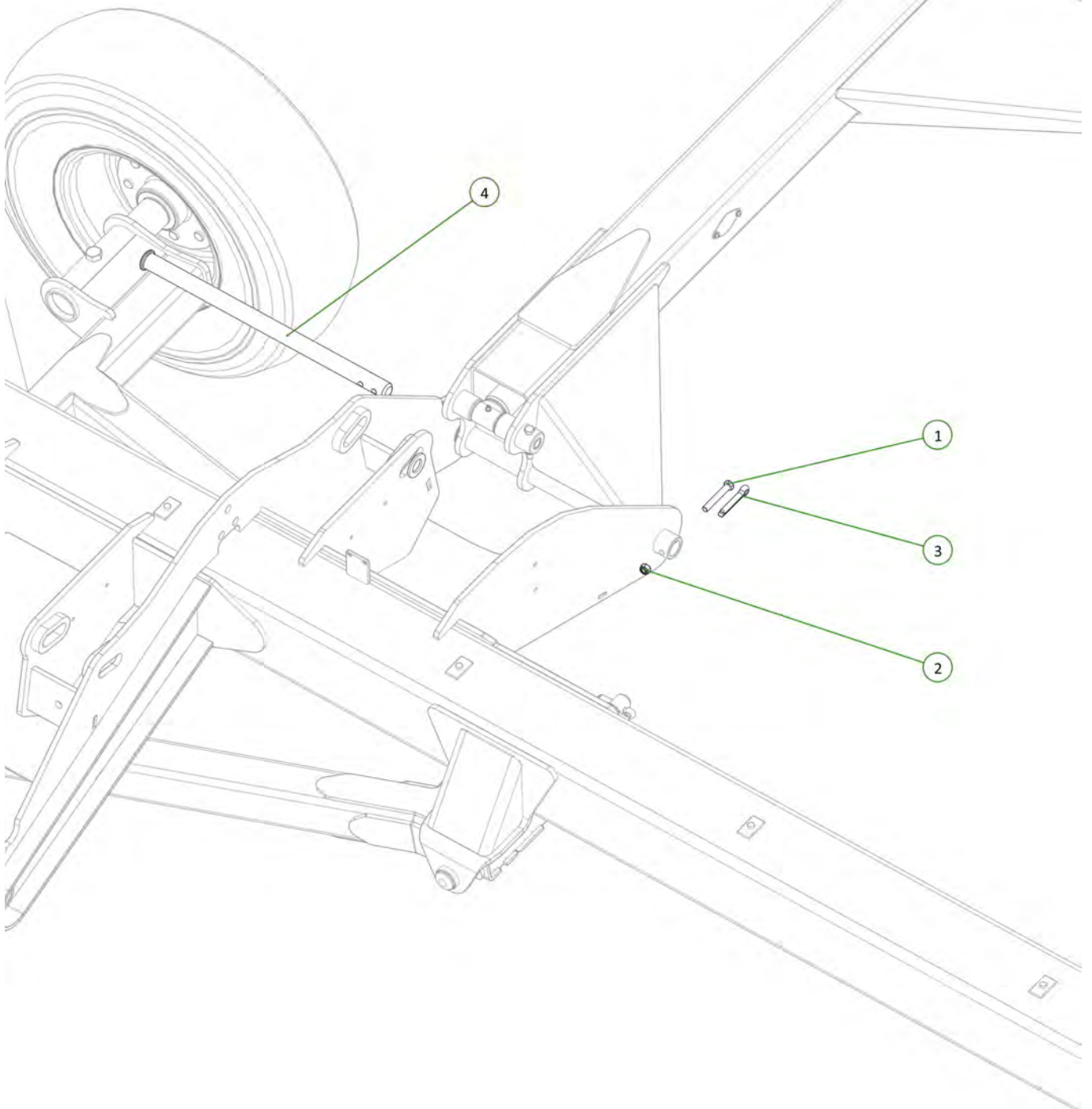

Item No.	Description	Qty	Number
1	M16 x 90 grade 8.8 zp Bolt	1	0211-1690
2	Nyloc Nut M16	1	0221-NYL16
3	Axle 2"R 3T 6 on 6"PCD 330 OHF Complete Assembly	1	0733-K5083T66S
4	11L15F3 tyre On Rim	1	0721-15X8

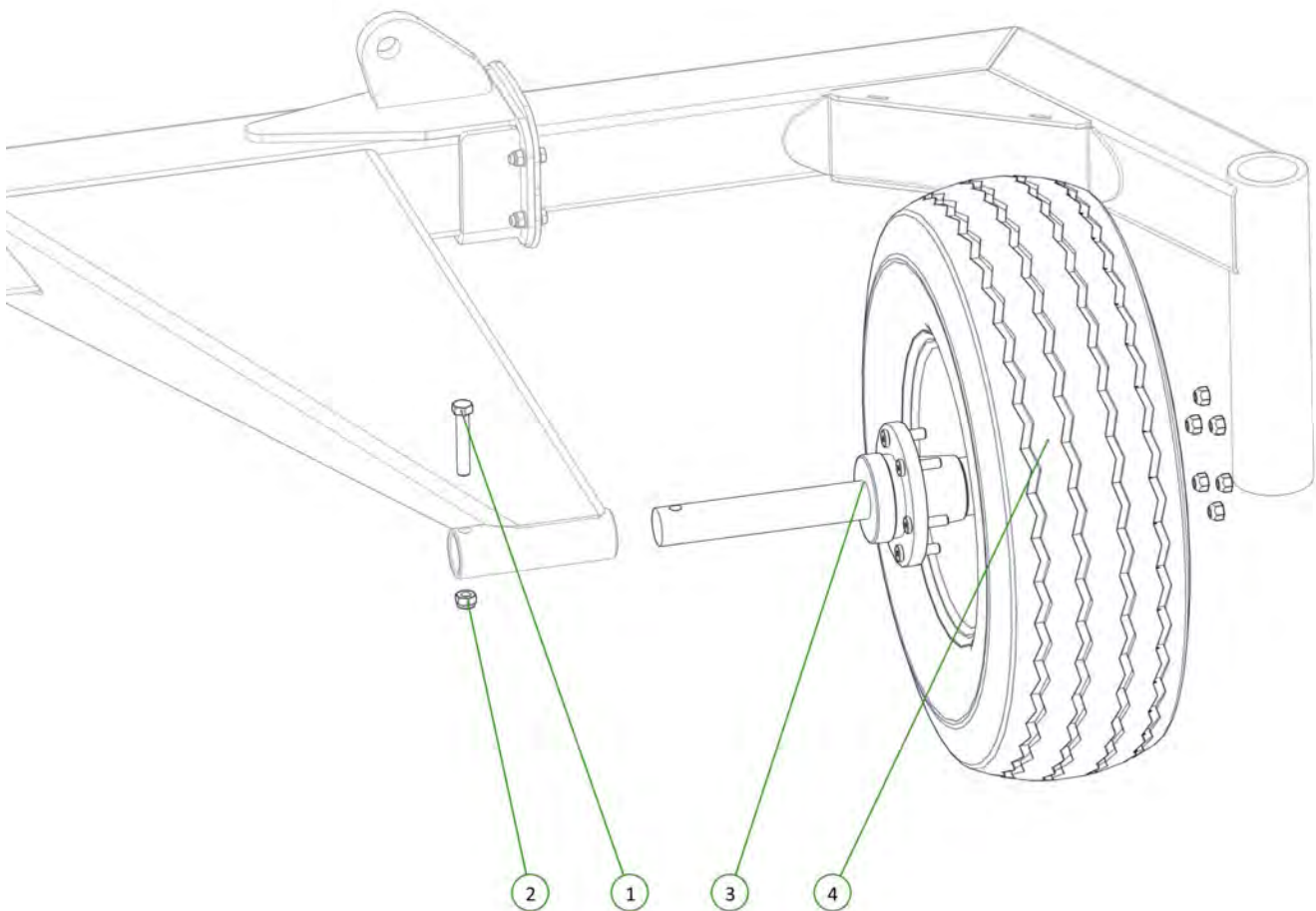

Item No.	Description	Qty	Number
1	LH Drop Leg	1	1510-25
2	M16 x 130 grade 8.8 zp Bolt	1	0211-16130
3	Nyloc Nut M16	1	0221-NYL16
4	Drop Leg Retaining Bush	1	1501-26

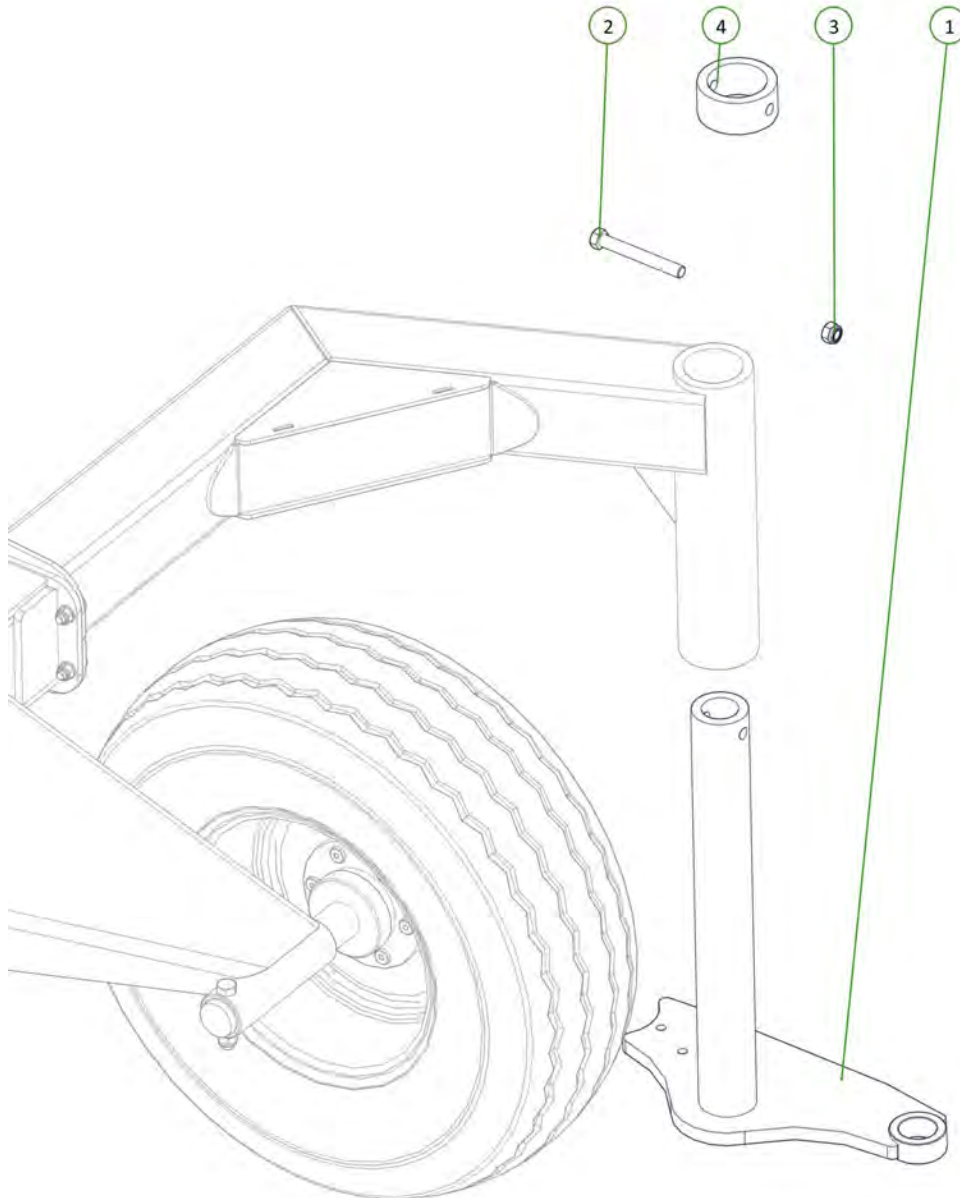

Item No.	Description	Qty	Number
1	Drop Leg Spacer Plate	1	1500-095
2	Drop Leg Bush Housing	1	1510-23
3	Nyloc Nut M12	3	0221-NYL12
4	M12 x 75 Class 8.8 ZP Bolt	3	0211-1275
5	Washer Flat M12	6	0231-F12

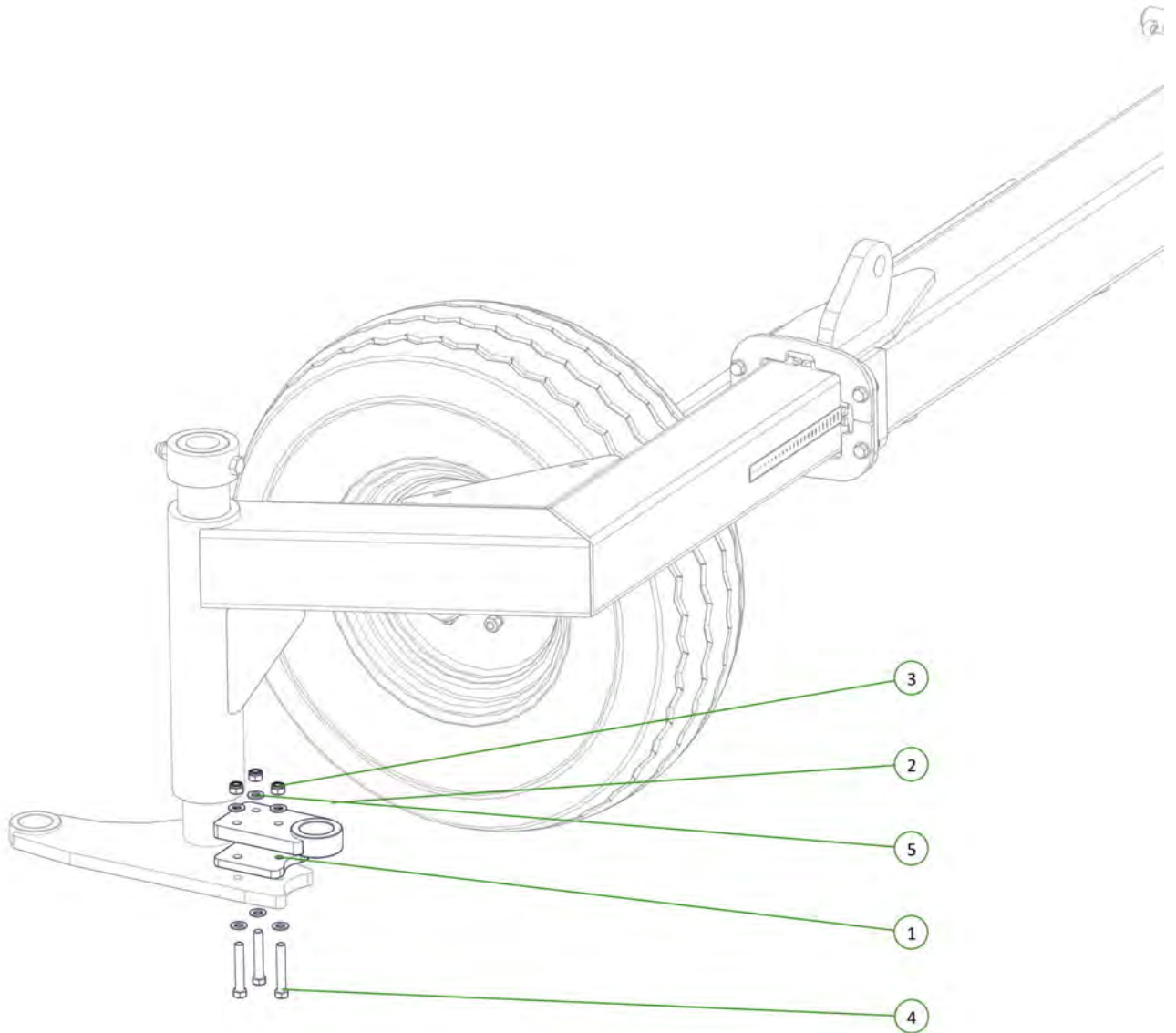

Item No.	Description	Qty	Number
1	Forged Clevis 21mm Bolt Hole	2	0801-FC21
2	Nyloc Nut M36	2	0221-NYL36
3	M36 x 105 grade 8.8 ZP Bolt	2	0211-36105
4	Wear Bush	2	1501-365033-SS

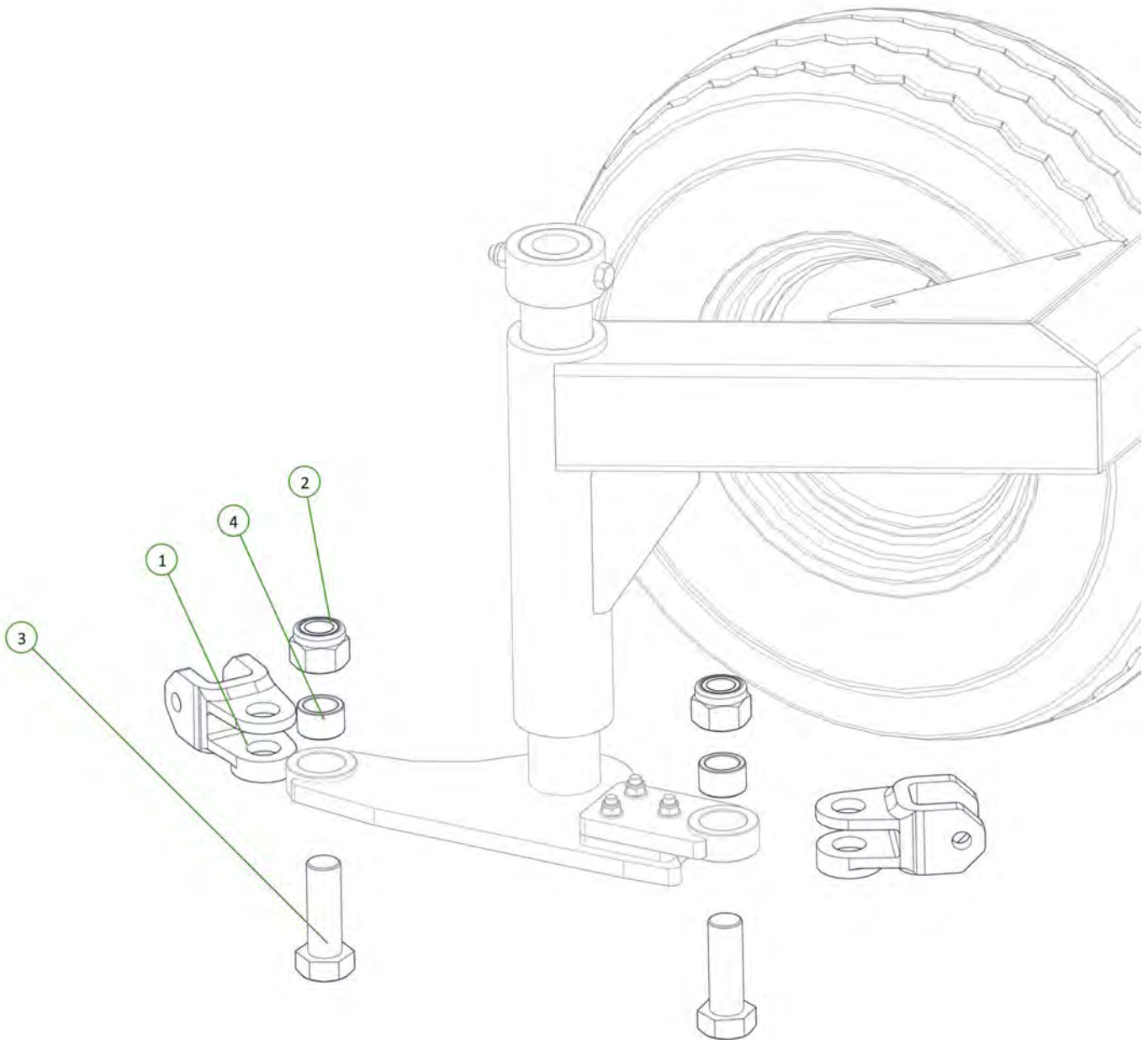

Item No.	Description	Qty	Number
1	M10 x 30 grade 8.8 ZP Bolt	10	0211-1030
2	Nyloc Nut M10	10	0221-NYL10
3	25mm Drop Leg Spacer Half	10	0801-CS25

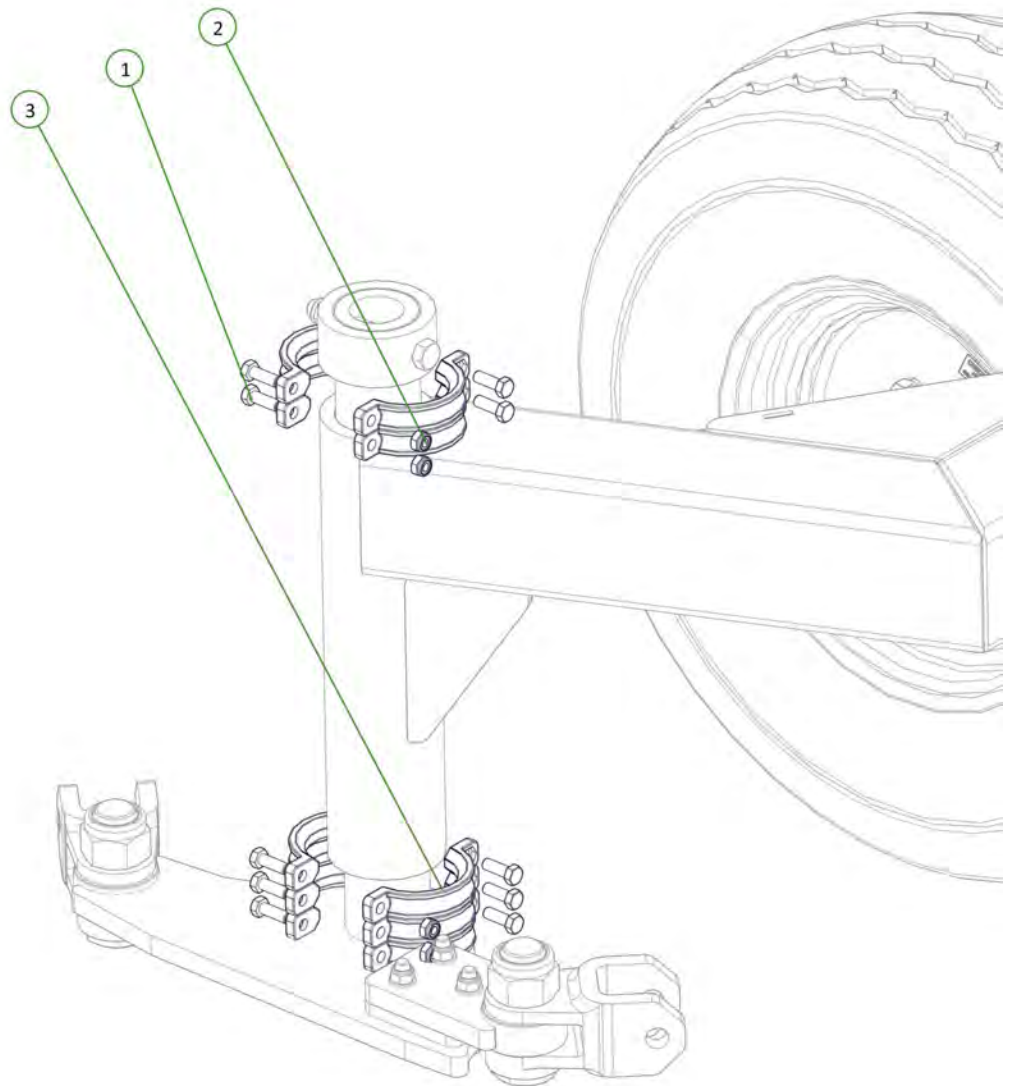

Item No.	Description	Qty	Number
1	Long Pivot Pin	1	1501-35615
2	COTTER PIN M13 X 63mm	1	0261-PINC1363
3	M12 x 80 Class 8.8 ZP Bolt	1	0211-1280
4	Nyloc Nut M12	1	0221-NYL12

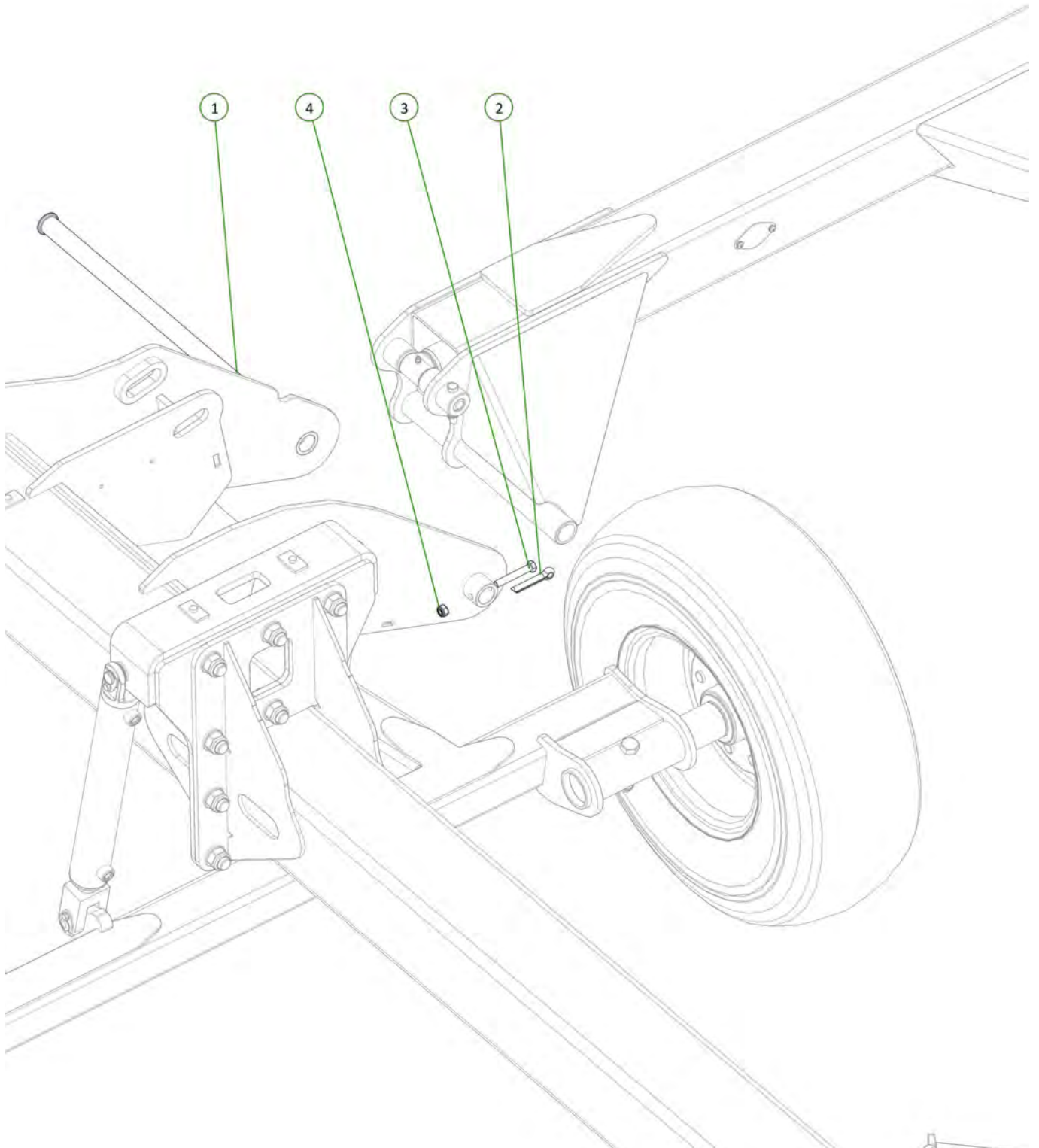

Item No.	Description	Qty	Number
1	M16 x 90 grade 8.8 zp Bolt	1	0211-1690
2	Nyloc Nut M16	1	0221-NYL16
3	Axle 2"R 3T 6 on 6"PCD 330 OHF Complete Assembly	1	0732-K5083TS
4	11L15 F3 Tyre on 6 on 6" Stud Rim	1	0751-11L15

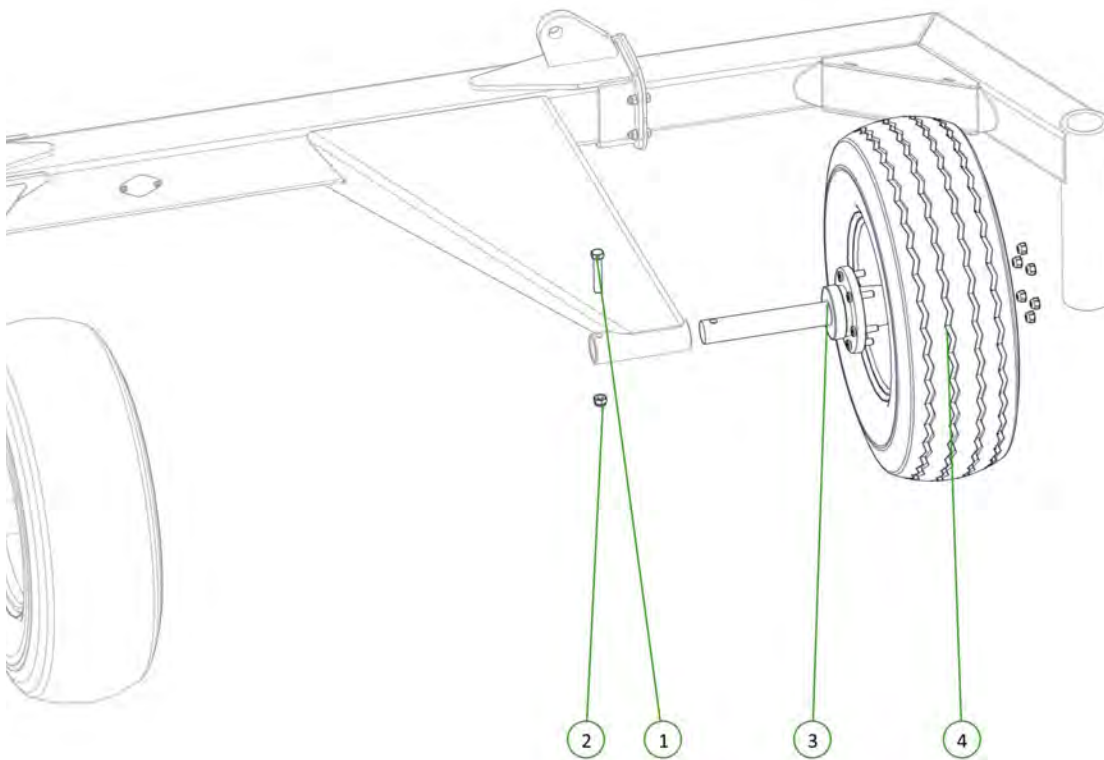

Item No.	Description	Qty	Number
1	M16 x 130 grade 8.8 zp Bolt	1	0211-16130
2	Nyloc Nut M16	1	0221-NYL16
3	Nyloc Nut M12	3	0221-NYL12
4	M12 x 75 Class 8.8 ZP Bolt	3	0211-1275
5	Drop Leg Spacer Plate	1	1500-095
6	Drop Leg Bush Housing	1	1510-23
7	Drop Leg Retaining Bush	1	1501-26
8	RH Drop Leg	1	1510-24
9	Washer Flat M12	6	0231-F12

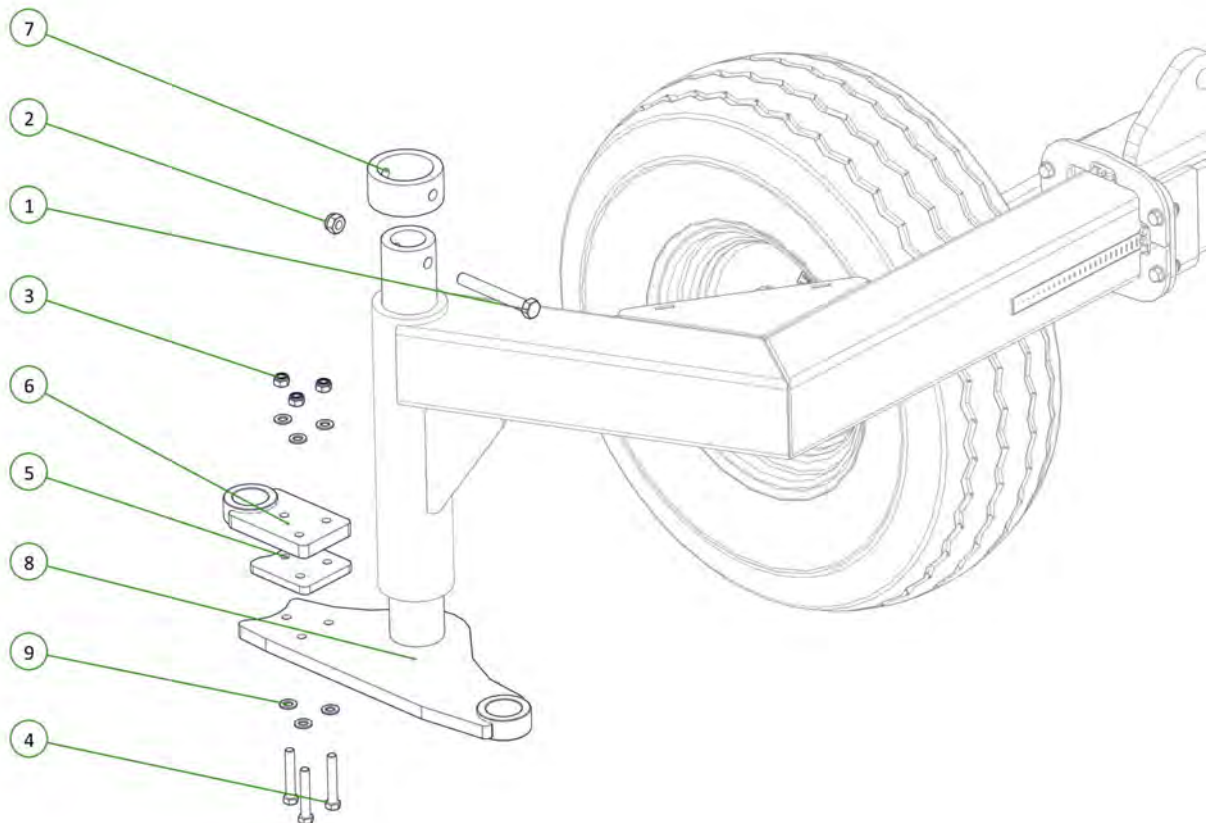

Item No.	Description	Qty	Number
1	Forged Clevis 21mm Bolt Hole	2	0801-FC21
2	M36 x 105 grade 8.8 zp Bolt	2	0211-36105
3	Nylac Nut M36	2	0221-NYL36
4	Stainless Steel Wear Bush	2	1501-365033-SS

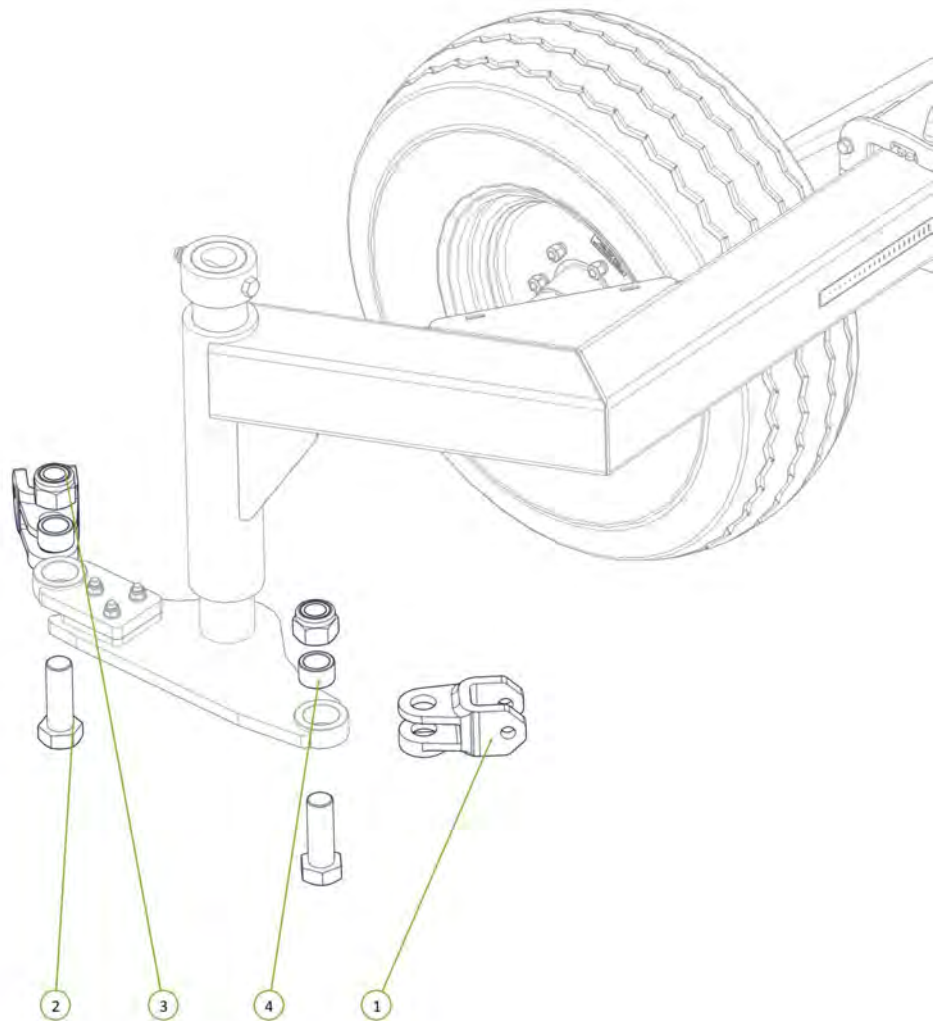
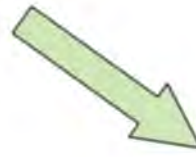

Item No.	Description	Qty	Number
1	25mm Drop Leg Spacer Half	10	0801-CS25
2	M10 x 30 grade 8.8 ZP Bolt	10	0211-1030
3	Nyloc Nut M10	10	0221-NYL10

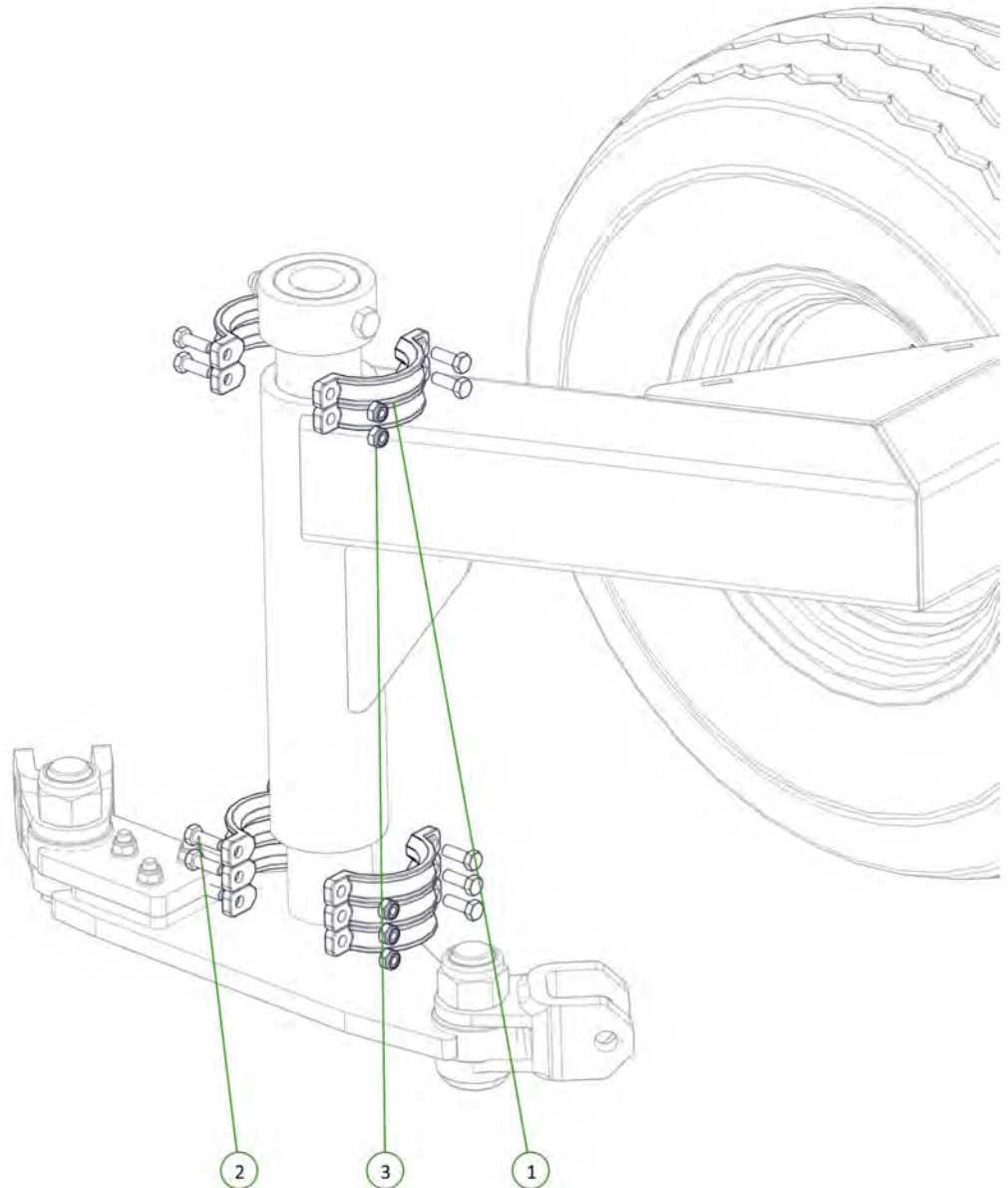

Item No.	Description	Qty	Number
1	M16 x 60 grade 8.8 zp Bolt	2	0211-1660
2	Washer Flat M16	4	0231-F16
3	Nyloc Nut M16	2	0221-NYL16
4	Rubber Wing Folding Buffer	2	1201-12

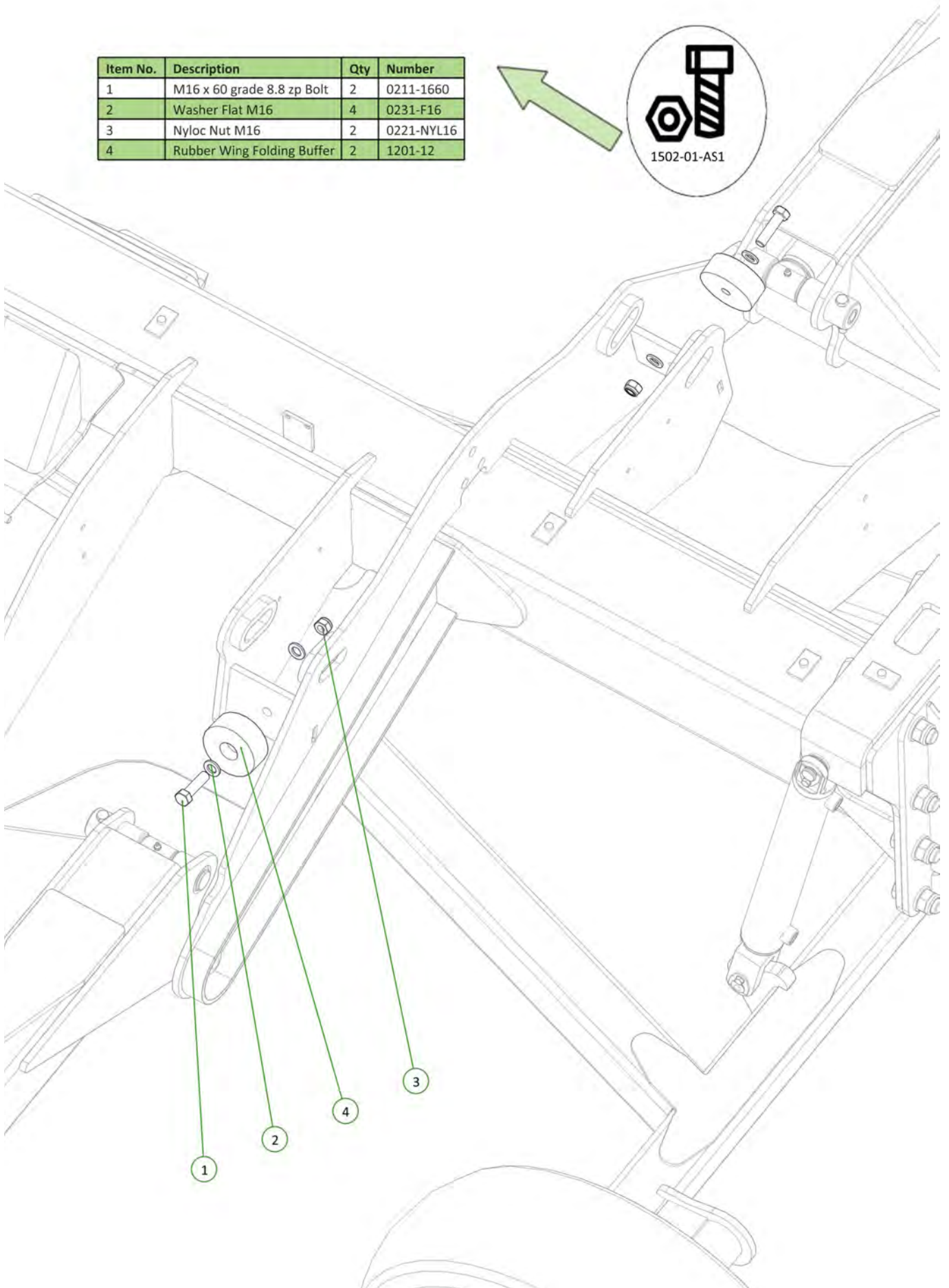
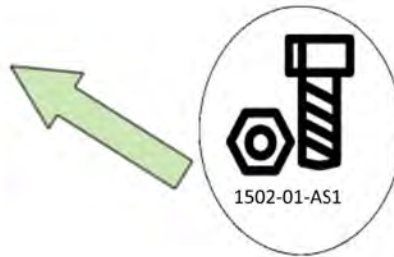

Item No.	Description	Qty	Number
1	Chain Mt Plate	2	1510-20
2	Nyloc Nut M12	2	0221-NYL12
3	M12 x 80 Class 8.8 ZP Bolt	2	0211-1280
4	Washer High Tensile 1 3/8"	2	0232-HT13-8
5	Cotter Pin M13 X 63mm	2	0261-PINC1363

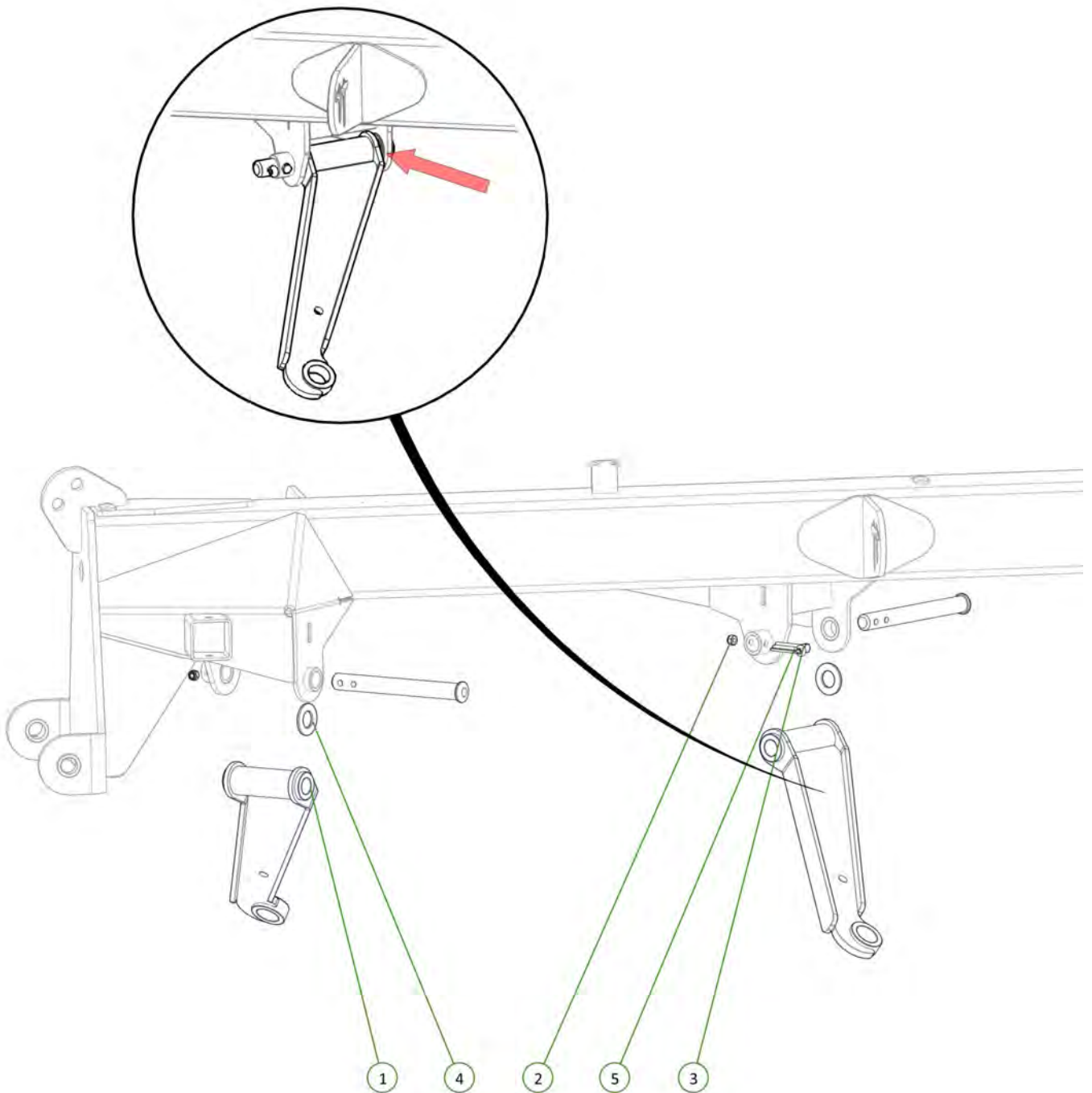

Item No.	Description	Qty	Number
1	Height Adjusting Chain Assembly 13 Link	1	0801-20MCA
2	Nyloc Nut M36	1	0221-NYL36
3	Wear Bush	1	1501-365033-SS
4	M36 x 105 grade 8.8 ZP Bolt	1	0211-36105
5	Height Adjustor Retaining Clip	1	0801-KE014
6	Forged Clevis 21mm Bolt Hole	1	0801-FC21

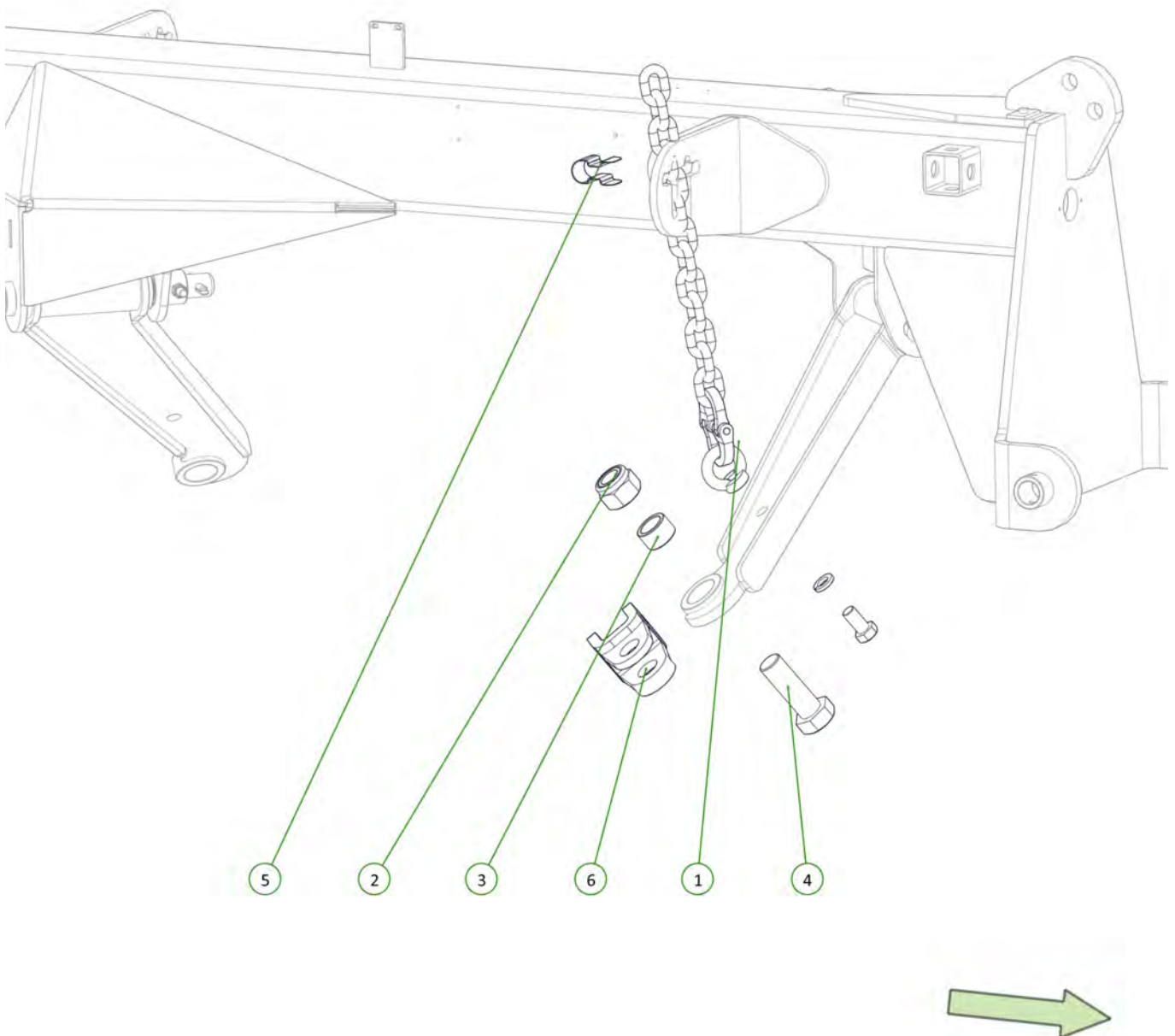

Item No.	Description	Qty	Number
1	Height Adjusting Chain Assembly 13 Link	1	0801-20MCA
2	Nyloc Nut M36	1	0221-NYL36
3	Forged Clevis 21mm Bolt Hole	1	0801-FC21
4	Wear Bush	1	1501-365033-SS
5	M36 x 105 grade 8.8 ZP Bolt	1	0211-36105
6	Height Adjustor Retaining Clip	1	0801-KE014

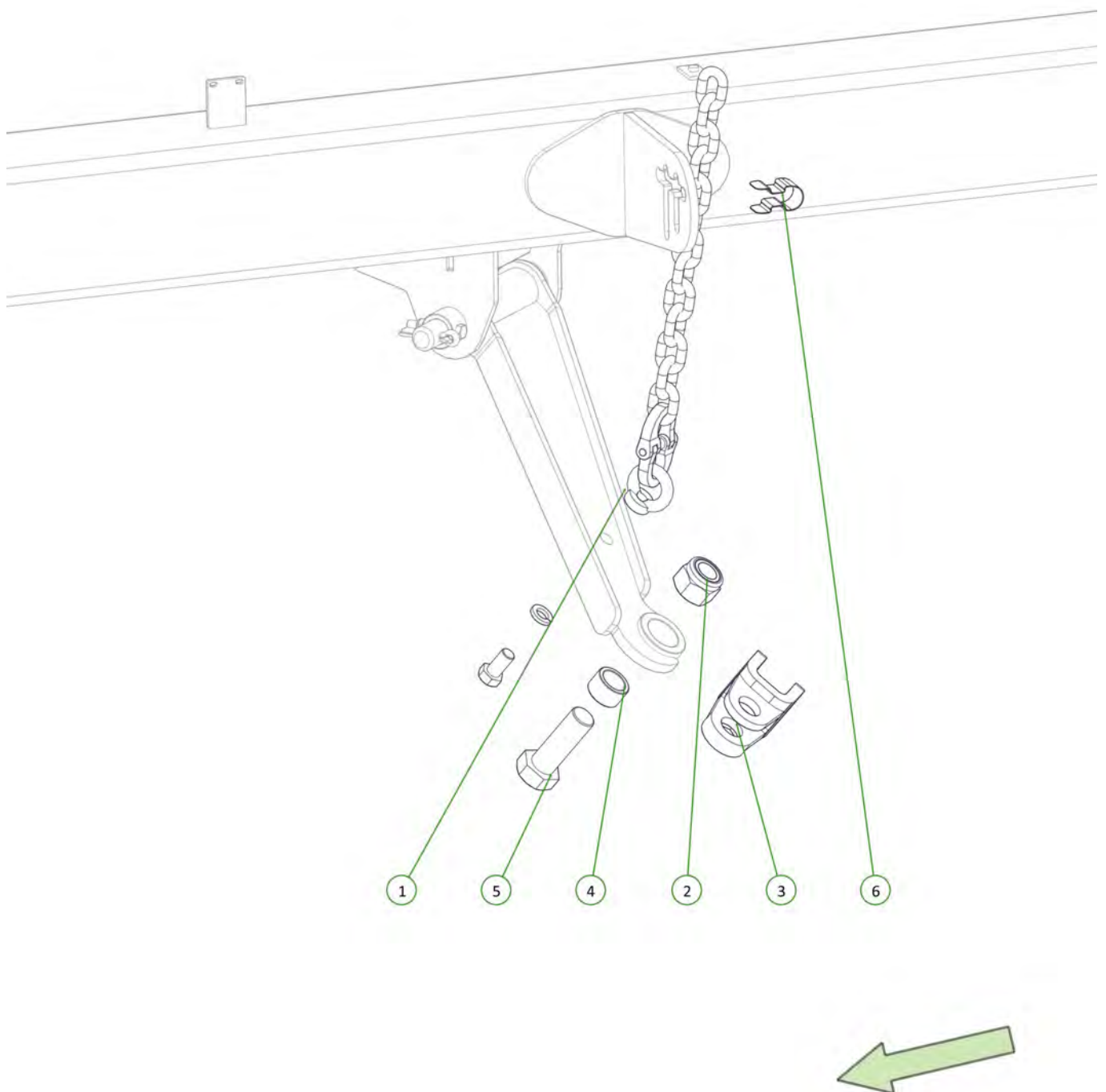

Item No.	Description	Qty	Number
1	M12 x 80 Class 8.8 ZP Bolt	2	0211-1280
2	Nyloc Nut M12	2	0221-NYL12
3	Washer High Tensile 1 3/8"	2	0232-HT13-8
4	Cotter Pin M13 X 63mm	2	0261-PINC1363
5	Short Pivot Pin	2	1501-35330
6	Chain Mt Plate	2	1510-20

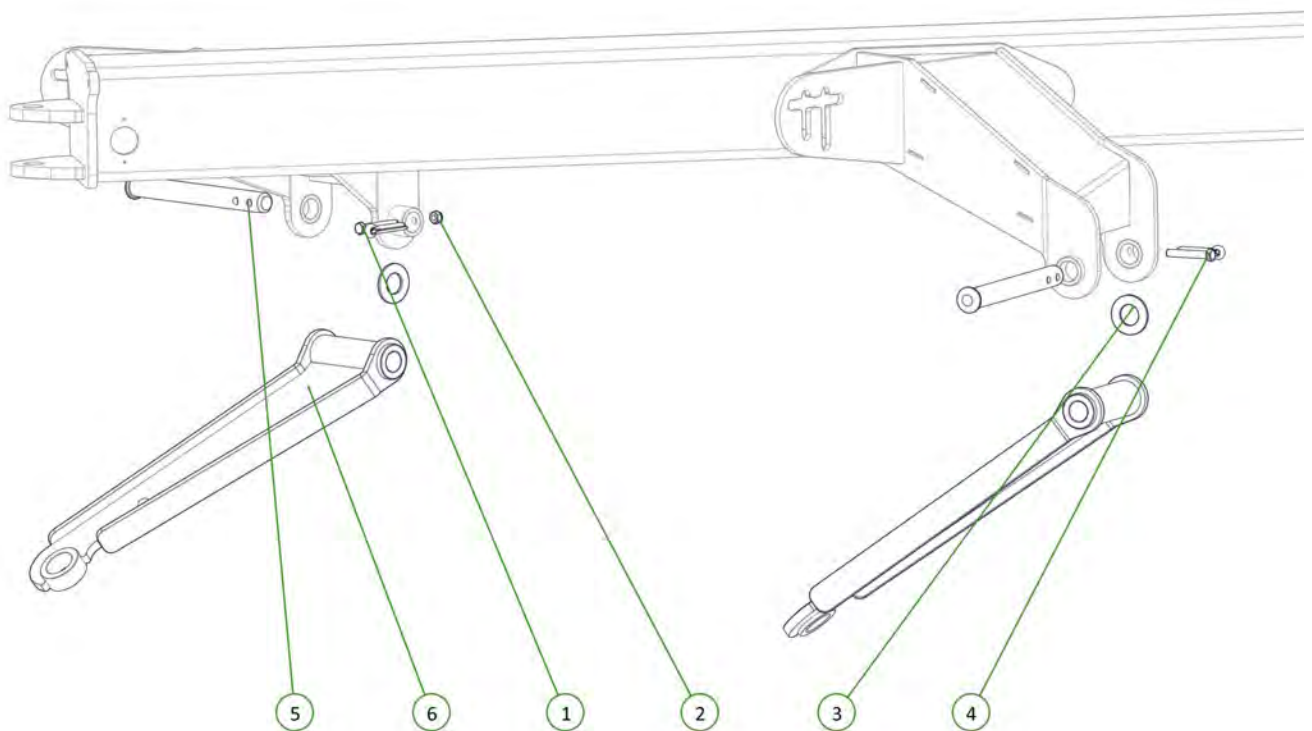

Item No.	Description	Qty	Number
1	M36 x 105 grade 8.8 ZP Bolt	1	0211-36105
2	Wear Bush	1	1501-365033-SS
3	Nyloc Nut M36	1	0221-NYL36
4	Height Adjusting Chain Assembly 13 Link	1	0801-20MCA
5	Forged Clevis 21mm Bolt Hole	1	0801-FC21
6	Height Adjustor Retaining Clip	1	0801-KE014

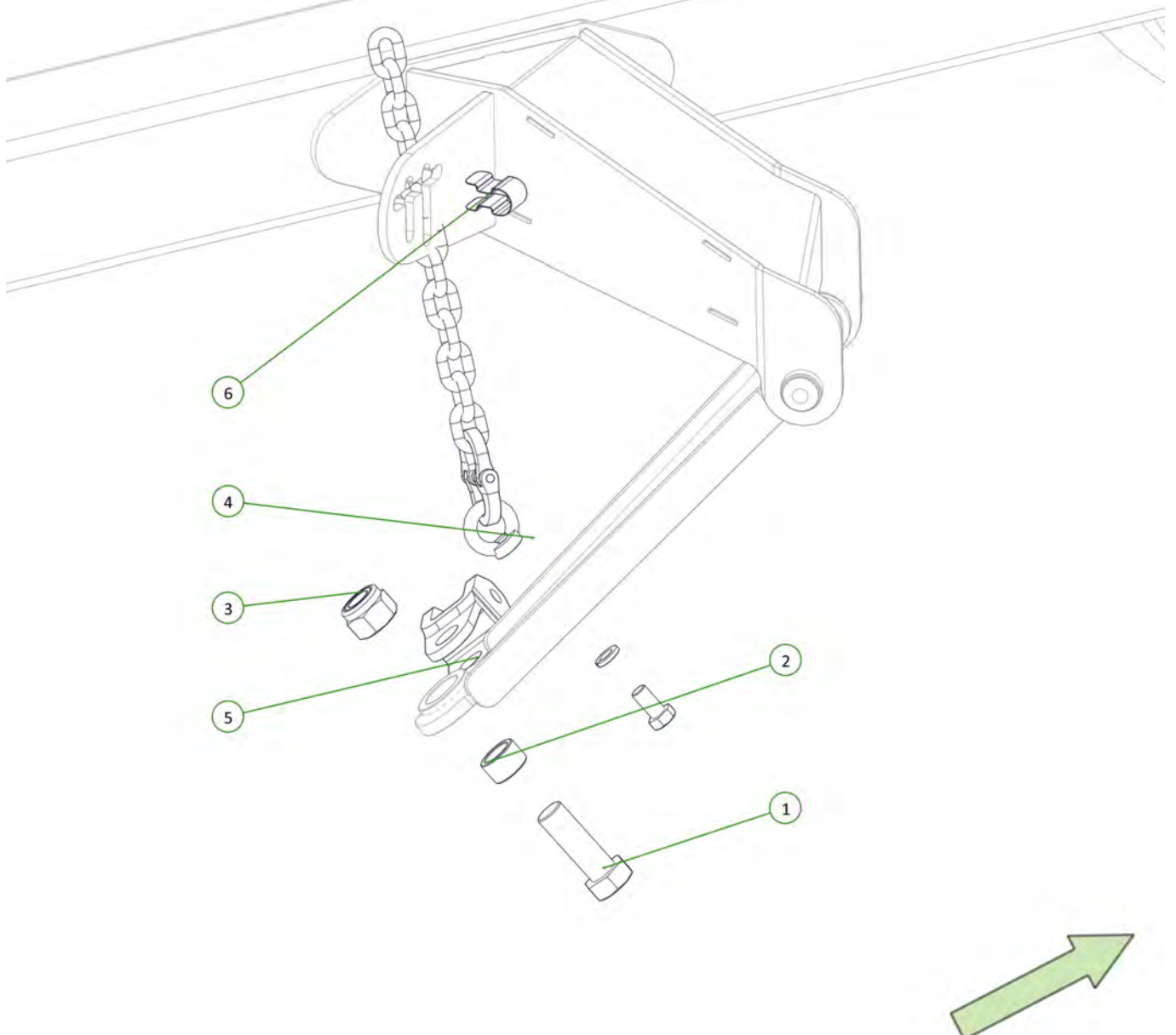

Item No.	Description	Qty	Number
1	Height Adjusting Chain Assembly 13 Link	1	0801-20MCA
2	M36 x 105 grade 8.8 ZP Bolt	1	0211-36105
3	Nyloc Nut M36	1	0221-NYL36
4	Forged Clevis 21mm Bolt Hole	1	0801-FC21
5	Height Adjustor Retaining Clip	1	0801-KE014
6	Wear Bush	1	1501-365033-SS

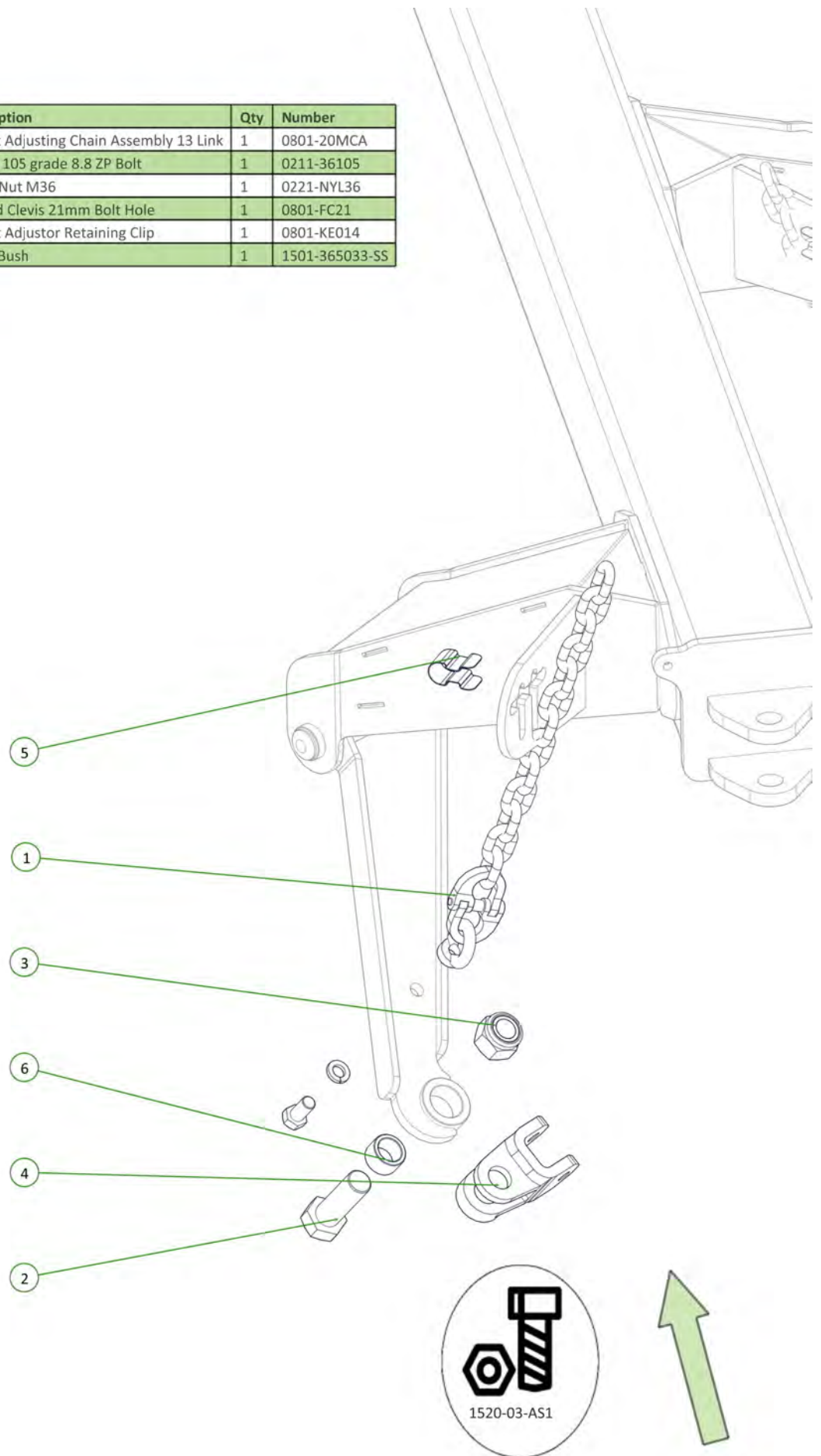

Item No.	Description	Qty	Number
1	6m Drawbar Frame	1	1520-08
2	35 ID x 50mm DU Bush	2	0113-MB3550DU
3	Long Pivot Pin	1	1501-35615
4	Nyloc Nut M12	1	0221-NYL12
5	M12 x 80 Class 8.8 ZP Bolt	1	0211-1280
6	Cotter Pin M13 X 63mm	1	0261-PINC1363

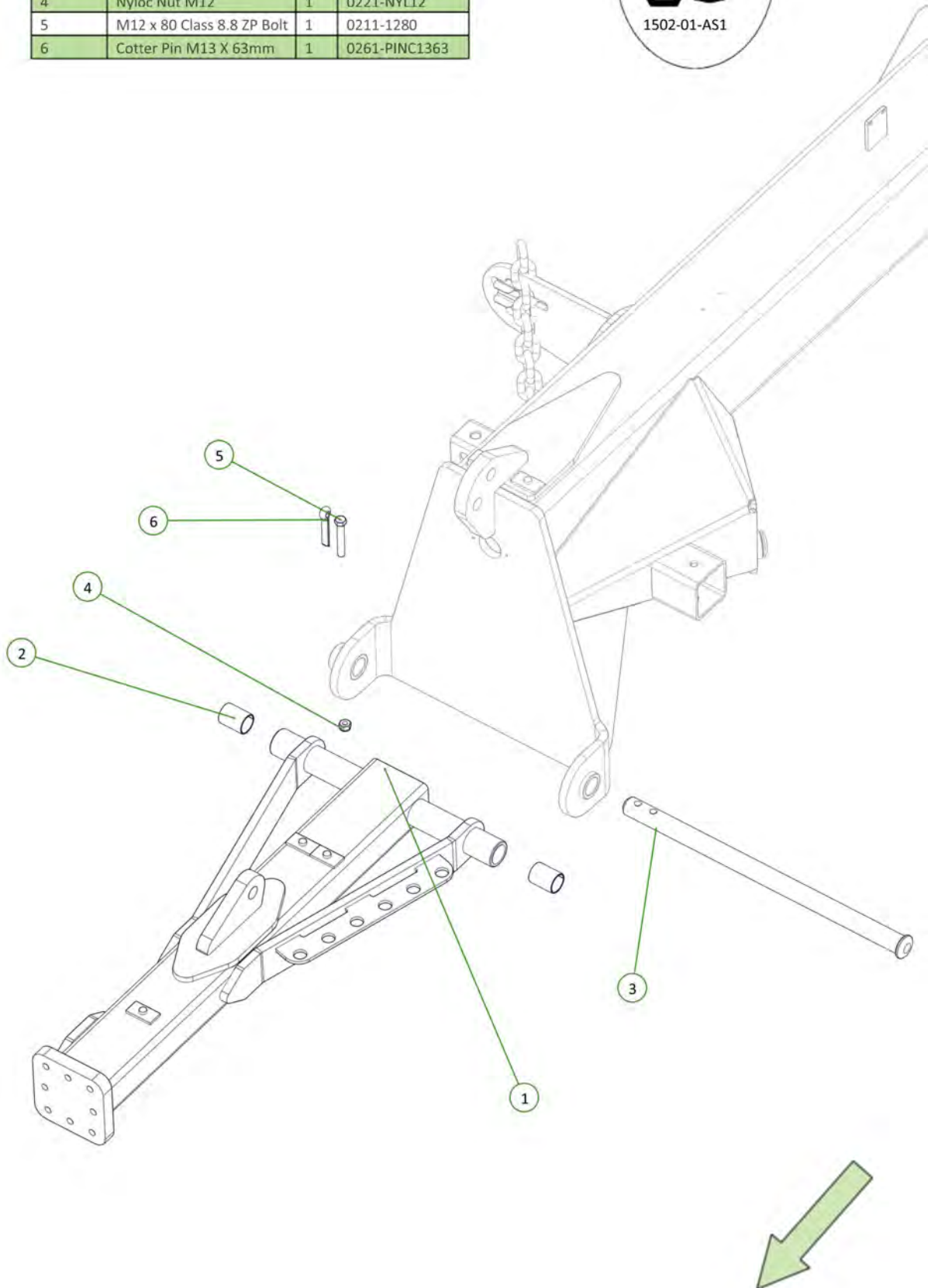

Item No.	Description	Qty	Number
1	Socket Head Bolt M16 x 60 Class 10.9	2	0211-SH1660
2	M16 Spring Washer	8	0231-S16
3	Socket Head Bolt M16 x 55 Class 10.9	6	0211-SH1655
4	50mm Flanged Drawbar Eye	1	1501-RCB050MM
5	Safety Chain Assembly	1	0810-16
6	Washer Flat M16	8	0231-F16

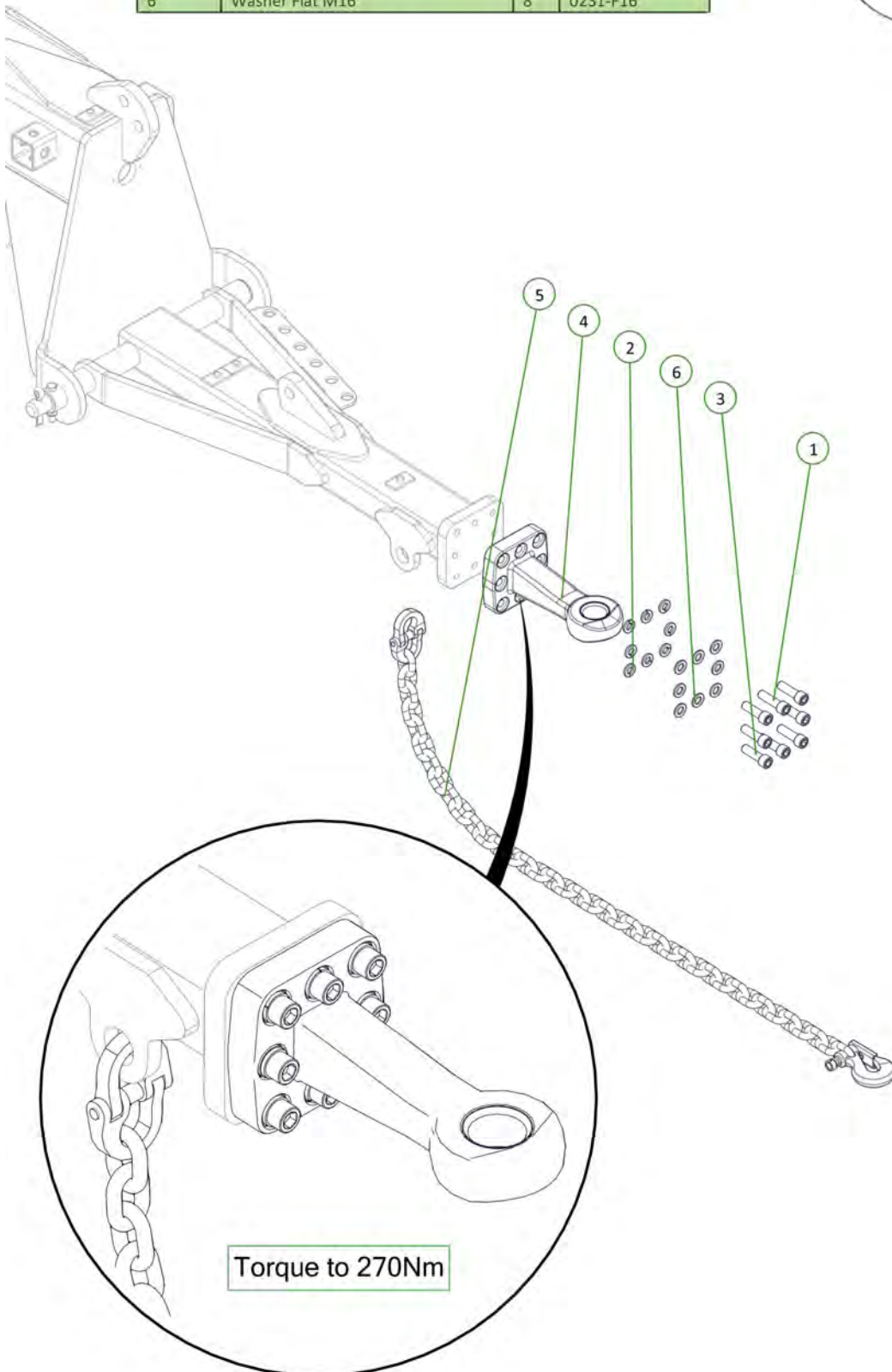

Item No.	Description	Qty	Number
1	Heavy Duty Ratchet Ram	1	0801-19RAJ013

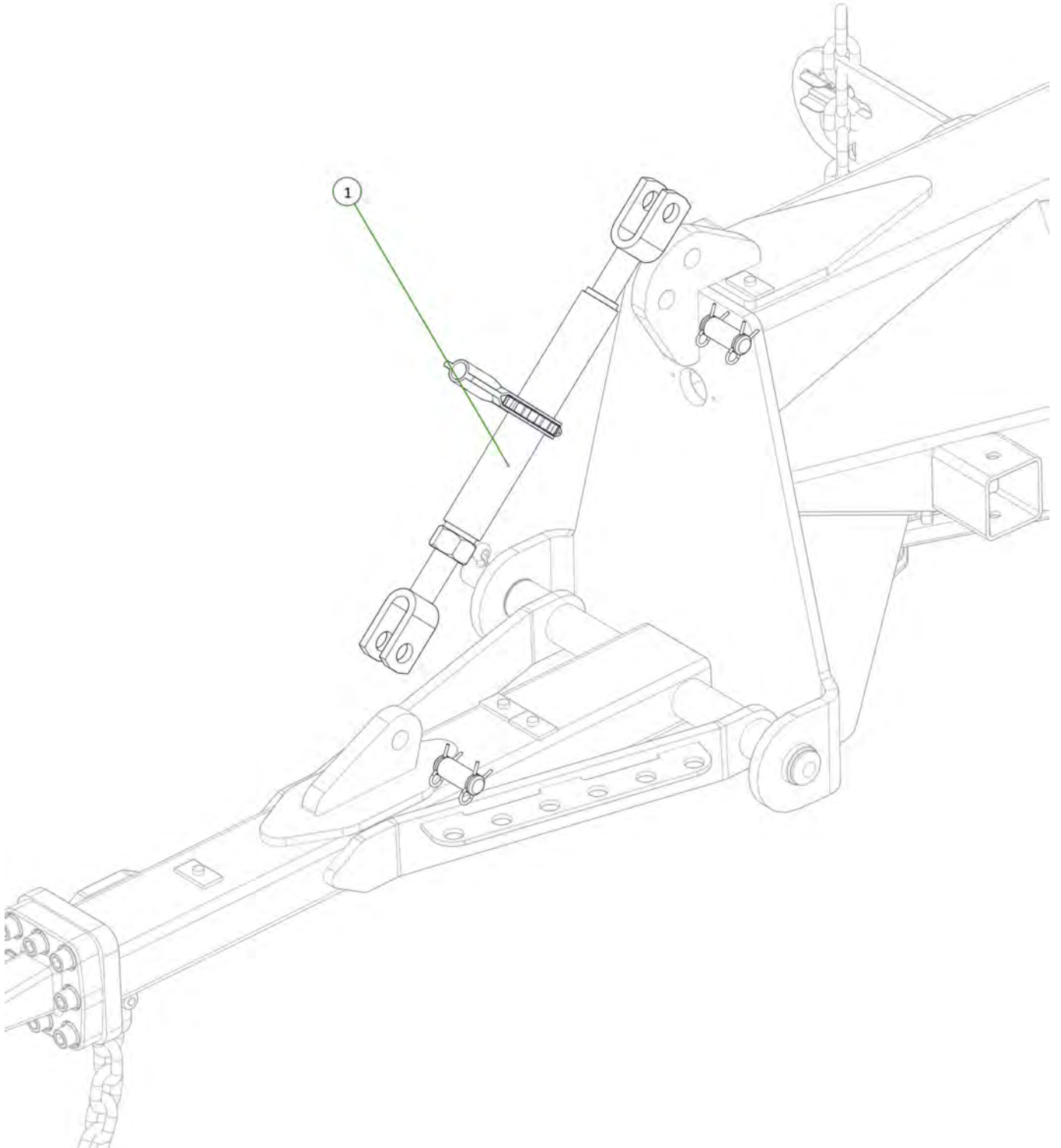

Item No.	Description	Qty	Number
1	Spacer bush	2	1501-325120
2	Cylinder Pin 1 1/4" x 245mm	1	1501-44102956-1
3	Washer Flat M30	2	0231-F30
4	S Locking Pin Clip 5mm	2	0801-KE012
5	3.5" Bore x 32" Stroke 1.75" Rod Cylinder with 4" Stop Tube	1	0311-3532ST

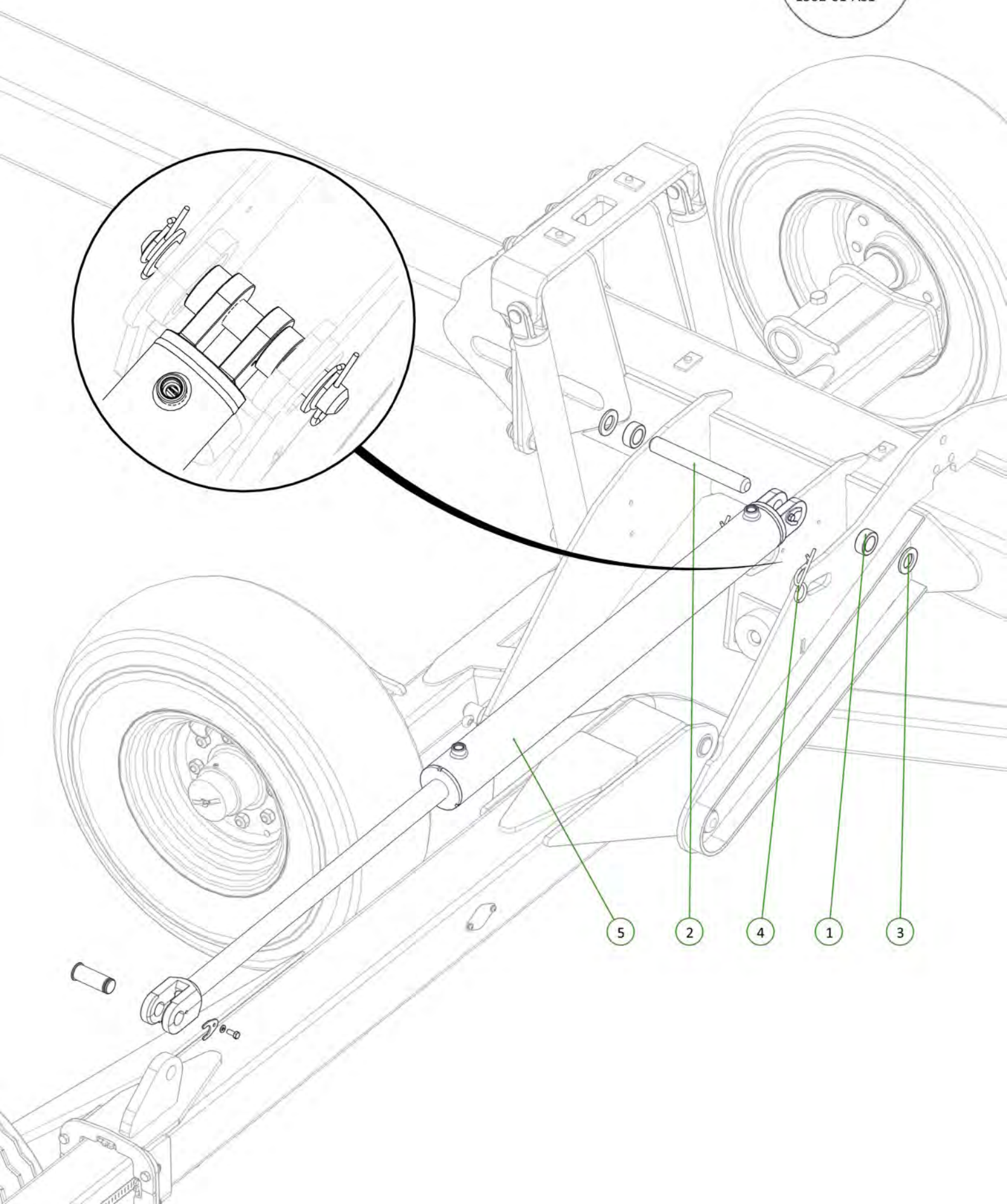
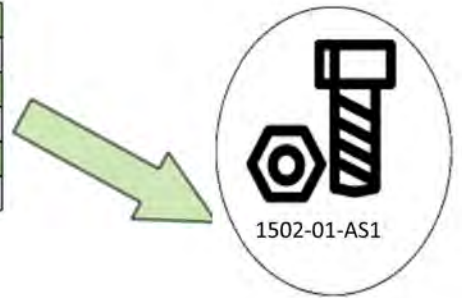

Item No.	Description	Qty	Number
1	Spacer bush	2	1501-325120
2	3.5" Bore x 32" Stroke 1.75" Rod Cylinder with 4" Stop Tube	1	0311-3532ST
3	S Locking Pin Clip 5mm	2	0801-KE012
4	Washer Flat M30	2	0231-F30
5	Cylinder Pin 1 1/4" x 245mm	1	1501-44102956-1

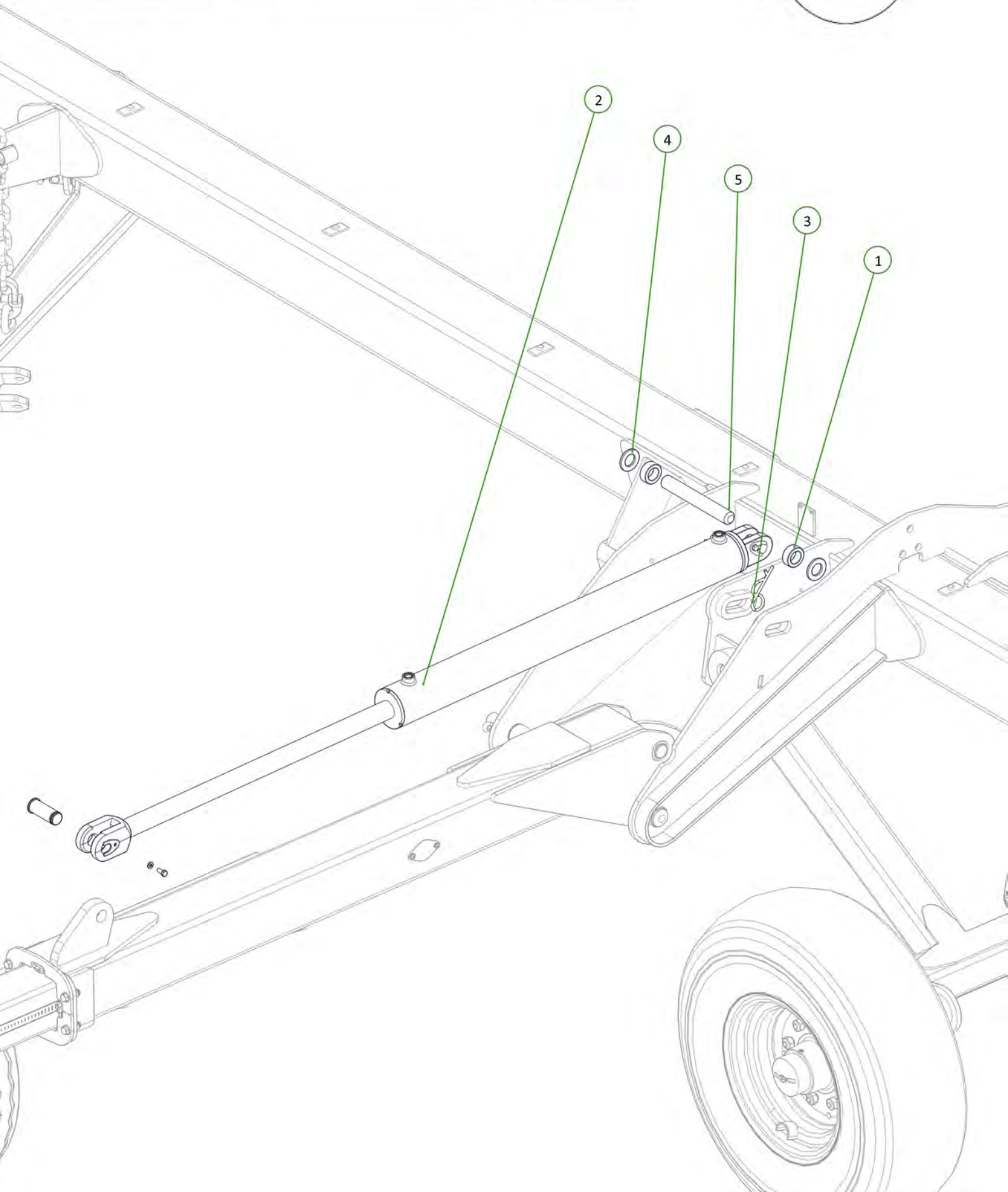
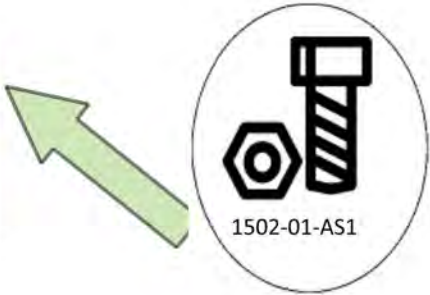

Item No.	Description	Qty	Number
1	M6 x 20mm Trilobe Screw	3	0211-M620MZPHTF
2	OPERATOR MANUAL CANNISTER	1	0801-OMC
3	M20 x 110 grade 10.9 ZP Short Thread Bolt	1	0211-20110 ST
4	Nyloc Nut M20	1	0221-NYL20
5	20mm Bolt Swivel Unit	1	0802-PCHB55

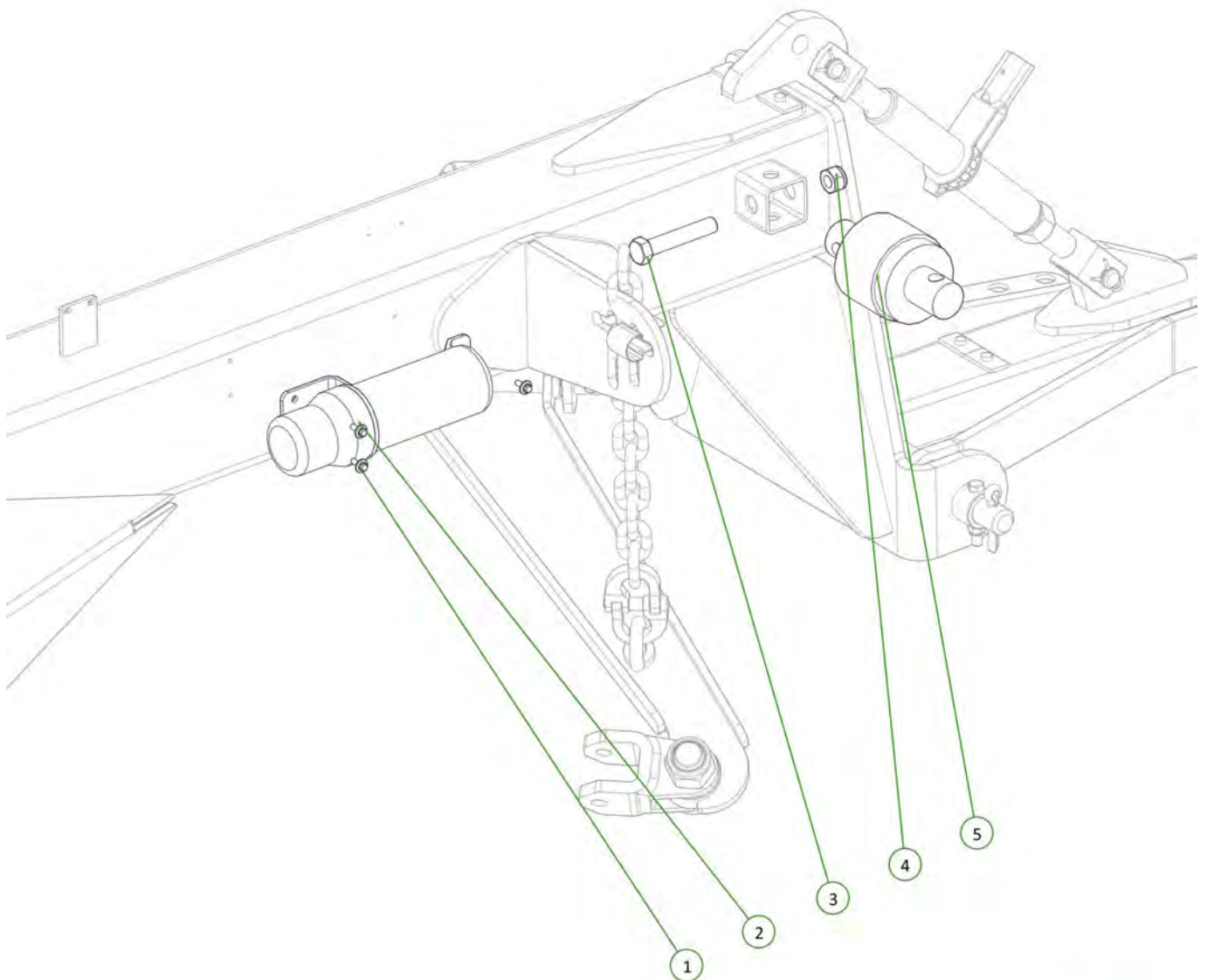

Item No.	Description	Qty	Number
1	20mm Bolt Swivel Unit	2	0802-PCHB55
2	M20 x 110 grade 10.9 ZP Short Thread Bolt	4	0211-20110 ST
3	Tie Plate Disc 20mm	2	0802-DCTP-20
4	Nyloc Nut M20	4	0221-NYL20

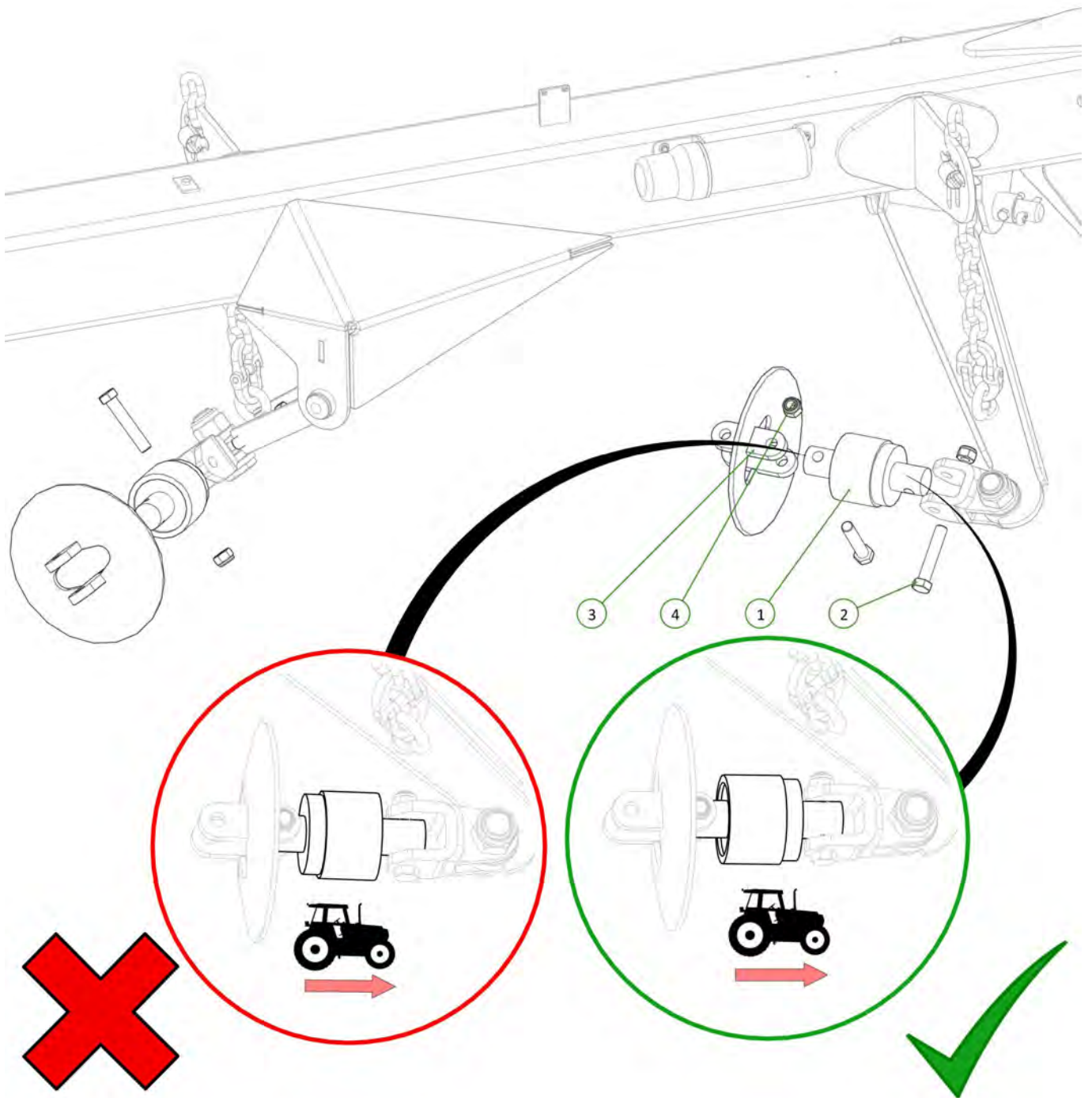
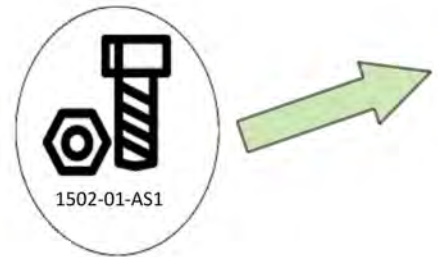

Item No.	Description	Qty	Number
1	20mm Bolt Swivel Unit	2	0802-PCHB55
2	Tie Plate Disc 20mm	2	0802-DCTP-20
3	M20 x 110 grade 10.9 ZP Short Thread Bolt	4	0211-20110 ST
4	Nyloc Nut M20	4	0221-NYL20

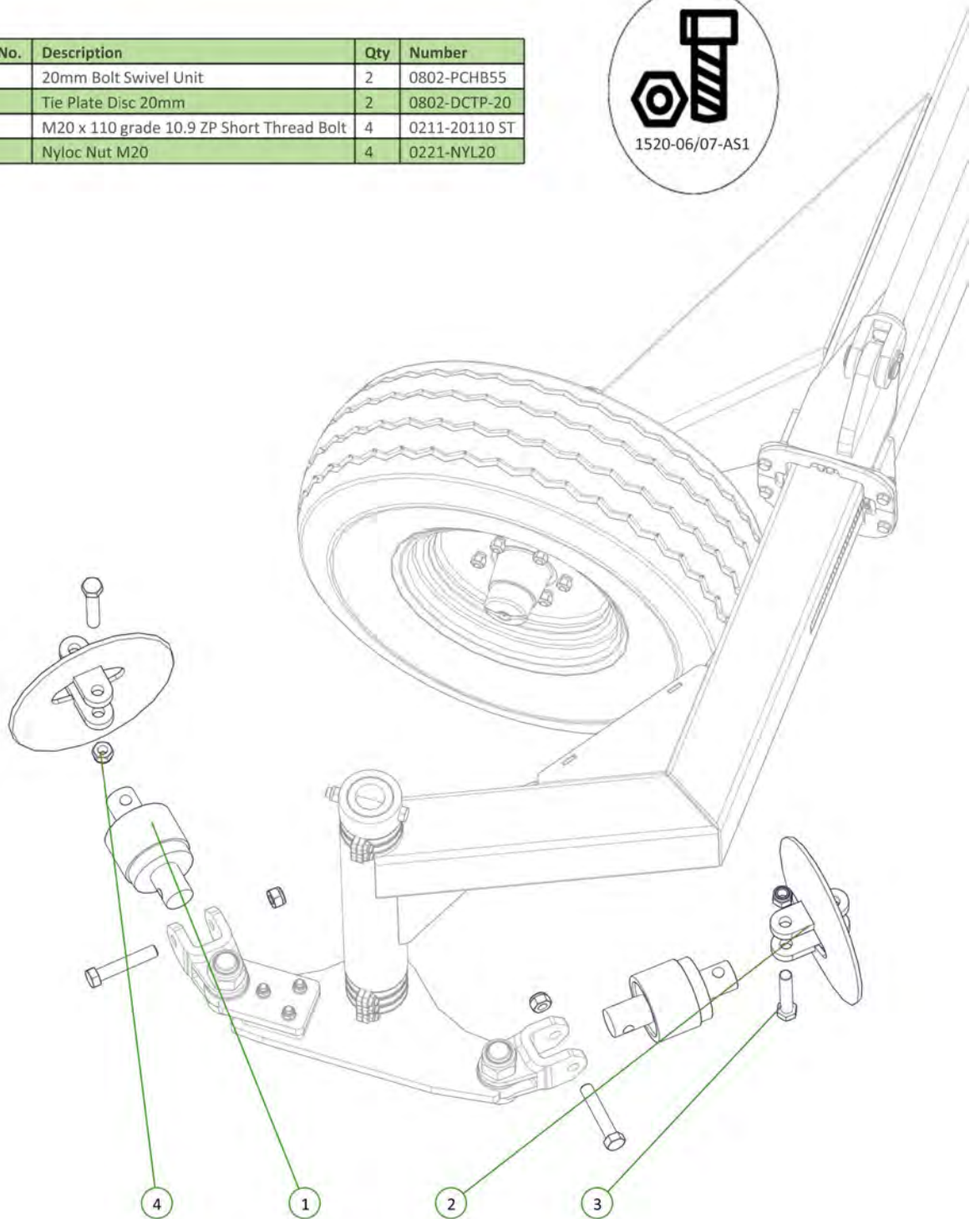

Item No.	Description	Qty	Number
1	20mm Swivel Bearing unit	2	0802-PCHB55
2	M20 x 110 grade 10.9 ZP Short Thread Bolt	4	0211-20110 ST
3	Nyloc Nut M20	4	0221-NYL20
4	Tie Plate Disc 20mm	2	0802-DCTP-20

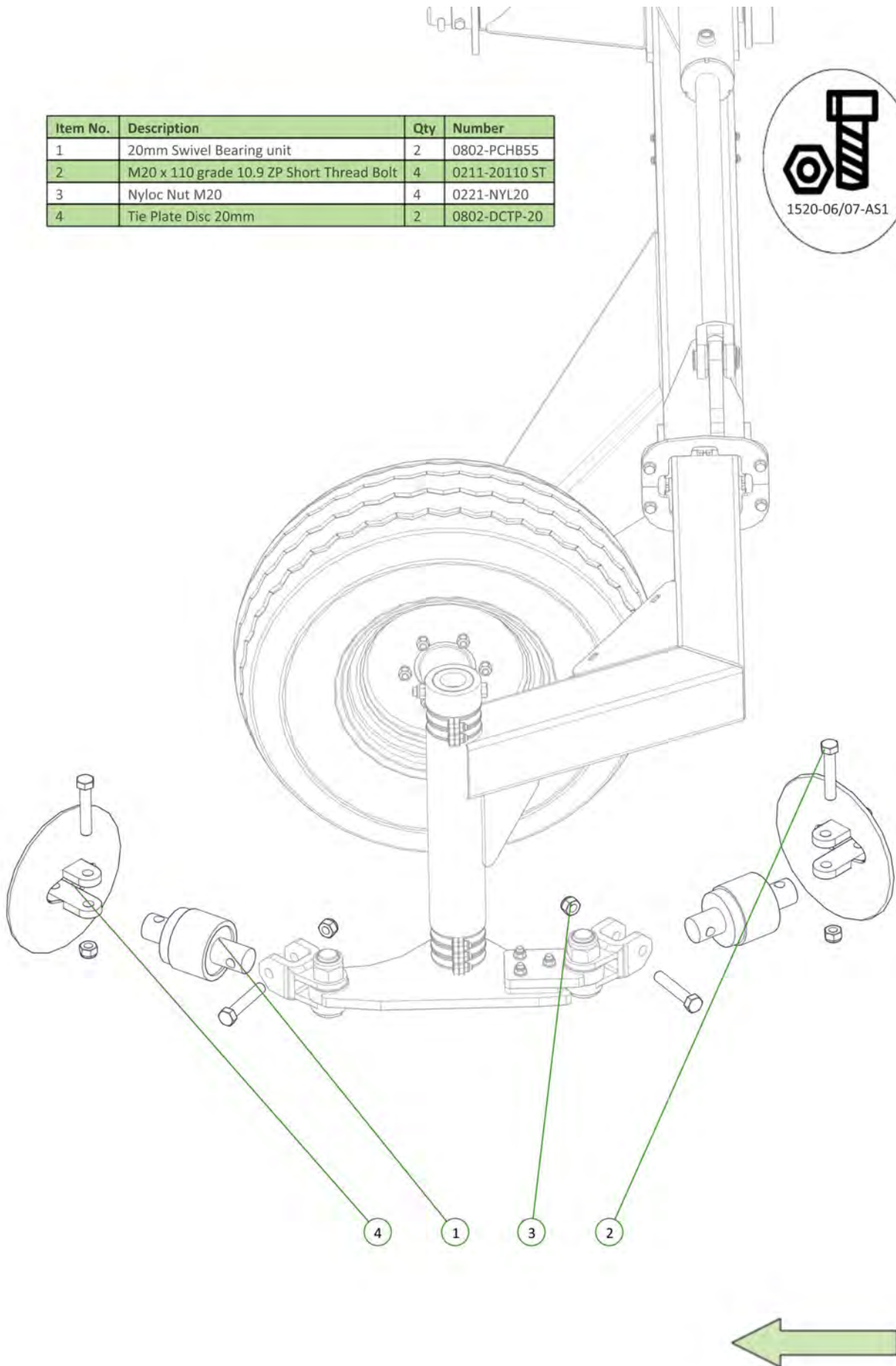

Item No.	Description	Qty	Number
1	Tie Plate Disc 20mm	2	0802-DCTP-20
2	20mm Bolt Swivel Unit	2	0802-PCHB55
3	M20 x 110 Class 10.9 ZP Short Thread Bolt	4	0211-20110 ST
4	Nyloc Nut M20	4	0221-NYL20

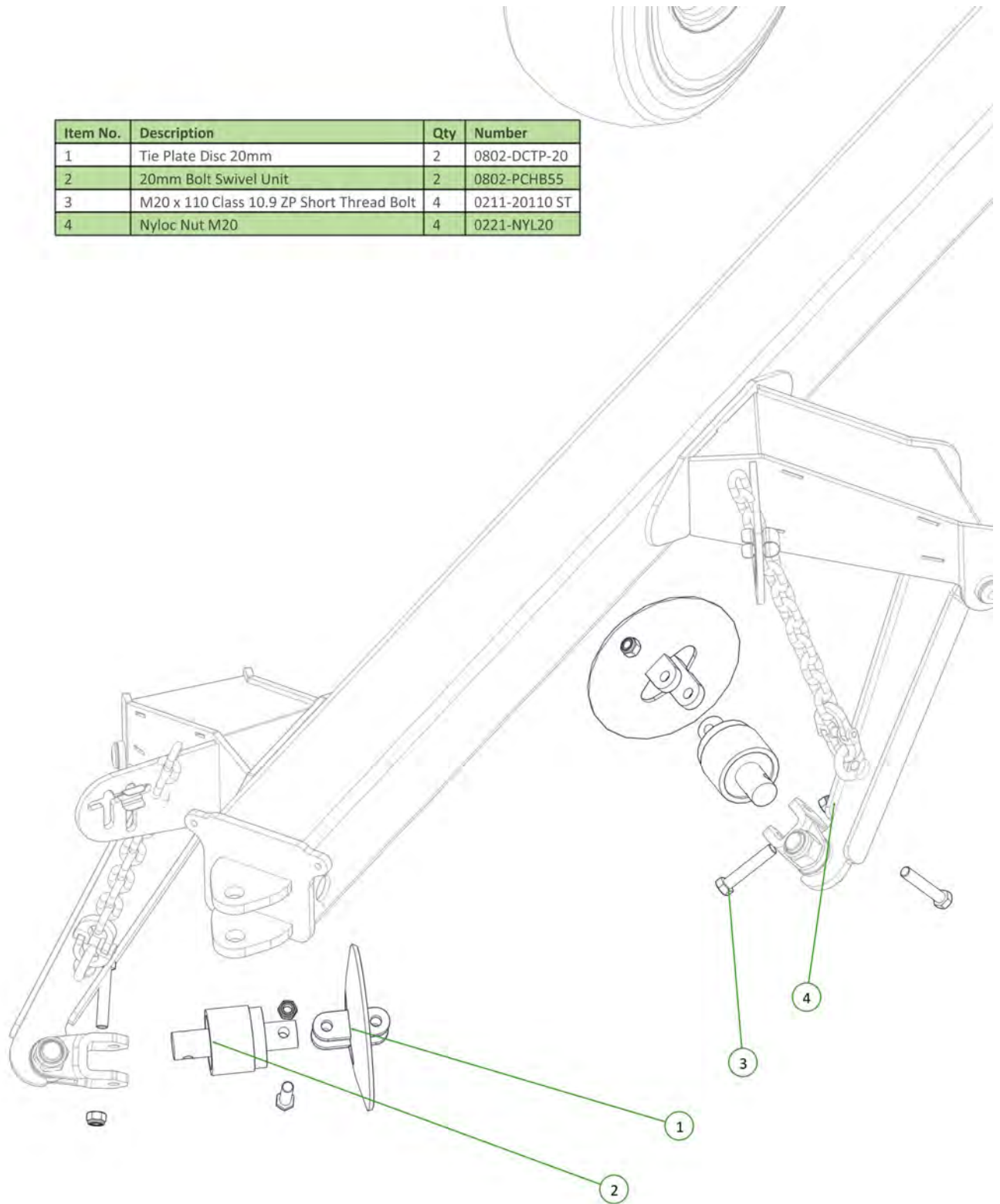

Item No.	Description	Qty	Number
1	Jack Pin	1	0801-B3077
2	Heavy Duty Jack Assembly	1	0810-37A

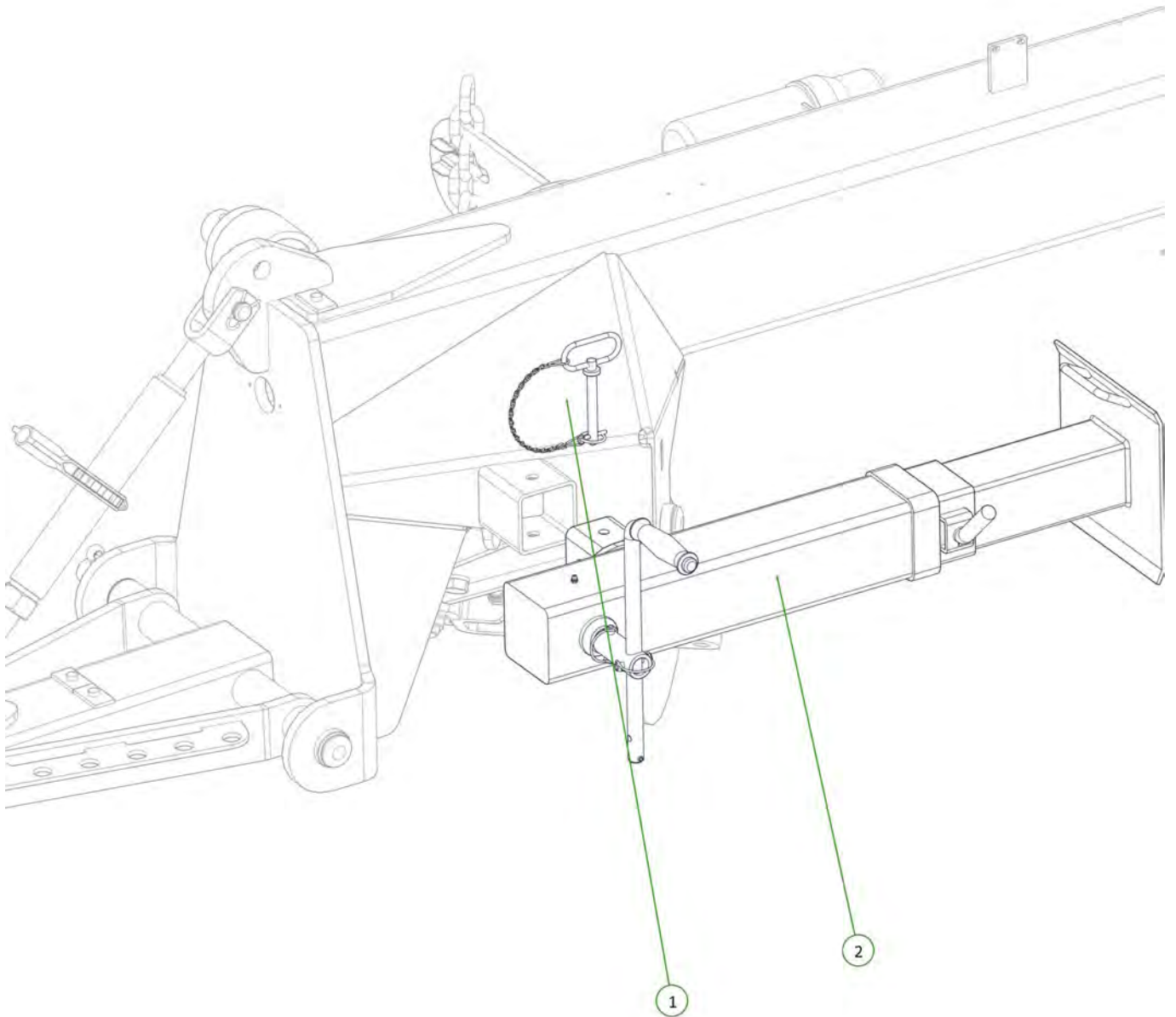

Item No.	Description	Qty	Number
1	M12 x 40 grade 8.8 ZP Bolt	6	0211-1240
2	Nyloc Nut M12	14	0221-NYL12
3	Washer Flat M12	8	0231-F12
4	U-Bolt M12 x 225 Deep x 202 Wide	4	0271-12225202
5	Chain Carrier Web LH Side	2	1500-086
6	Chain Carrier Web RH Side	2	1500-085
7	Chain Catch 6M	2	1500-084
8	Washer Flat M12	12	0231-F12

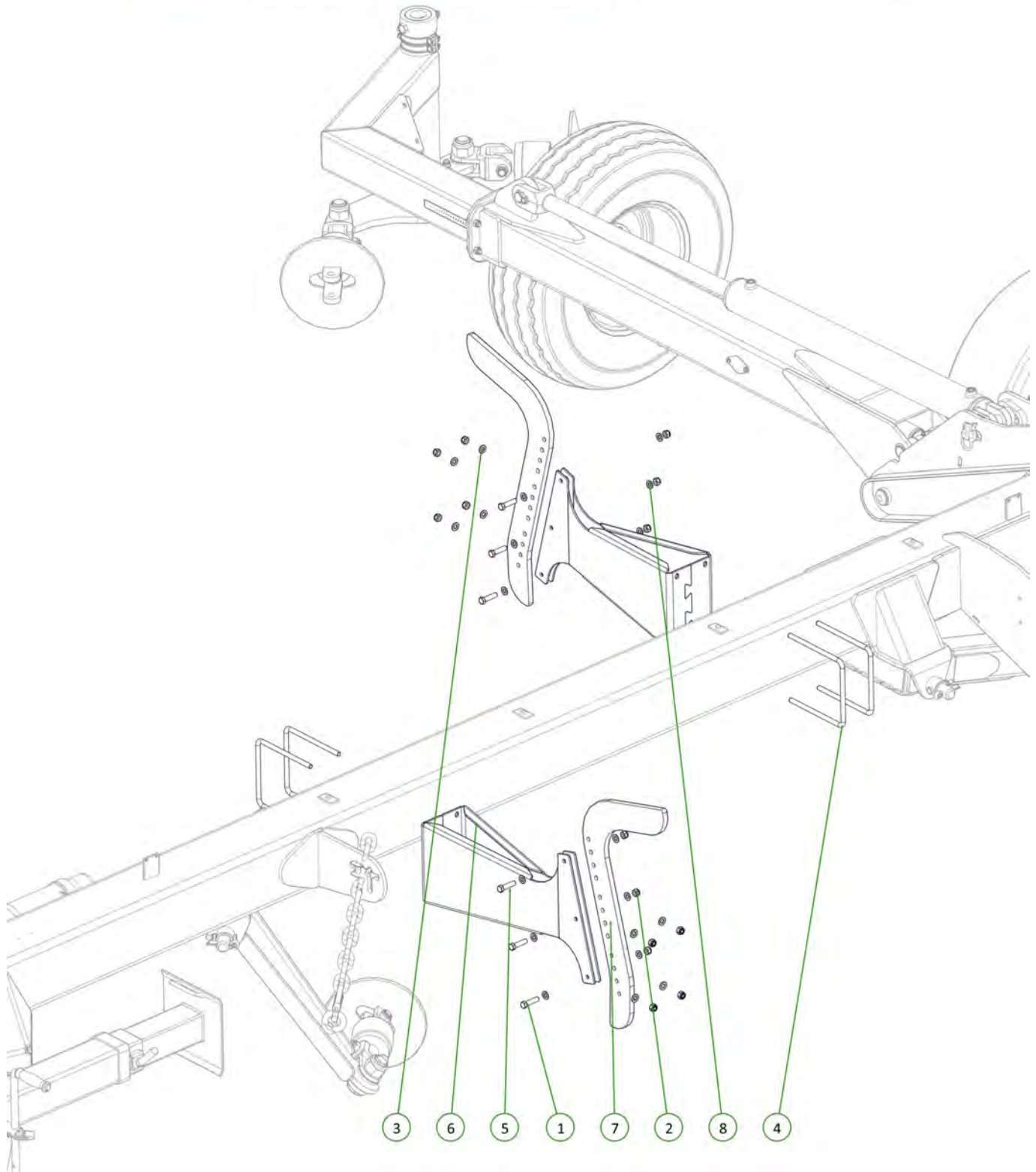
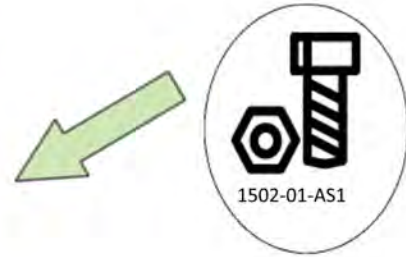

Item No.	Description	Qty	Number
1	U-Bolt M12 x 225 Deep x 202 Wide	4	0271-12225202
2	Nyloc Nut M12	14	0221-NYL12
3	Washer Flat M12	8	0231-F12
4	M12 x 40 grade 8.8 ZP Bolt	6	0211-1240
5	Chain Catch 6M	2	1500-084
6	Chain Carrier Web RH Side	2	1500-085
7	Chain Carrier Web LH Side	2 </td <td>1500-086</td>	1500-086
8	Washer Flat M12	12	0231-F12

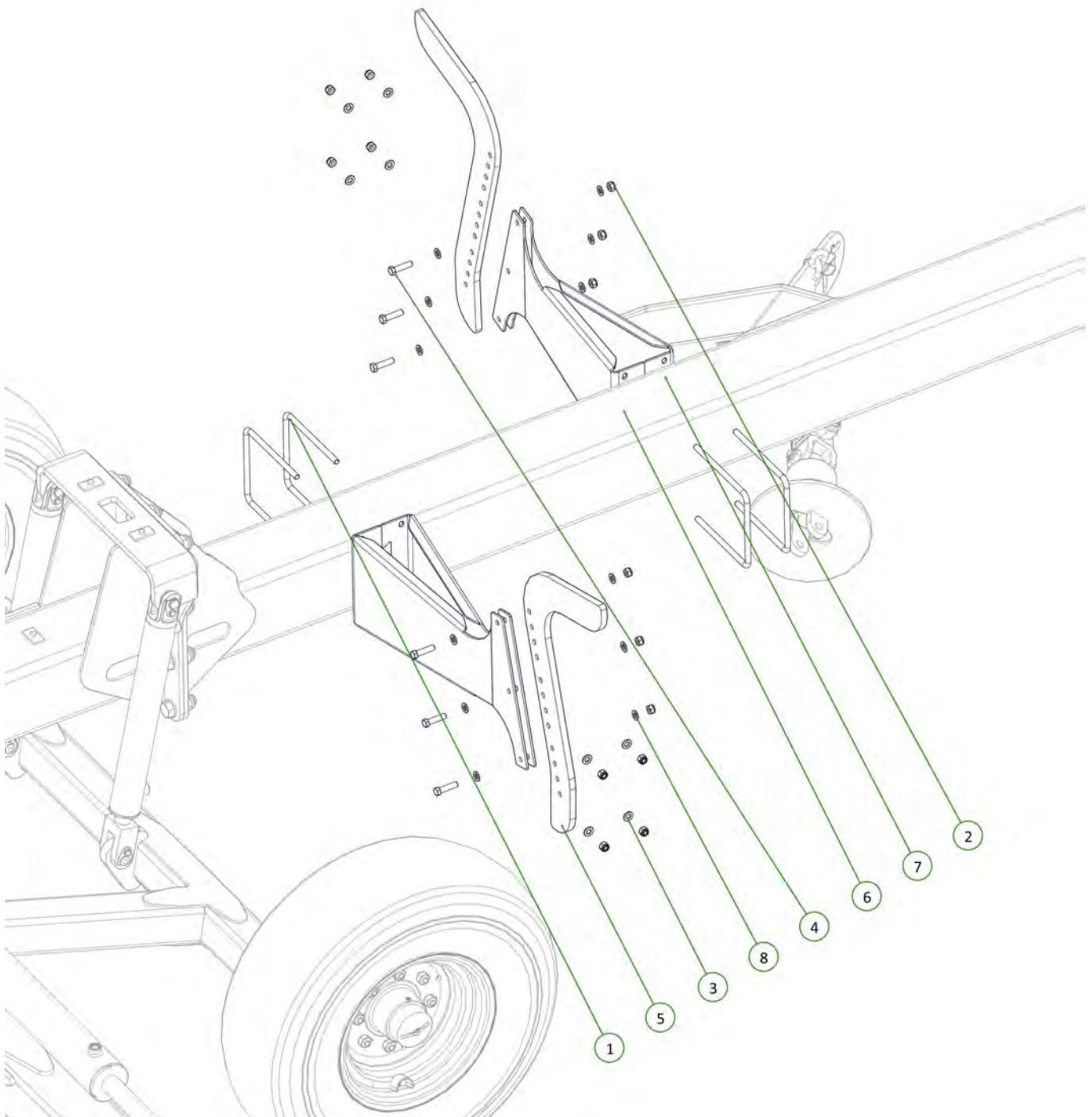
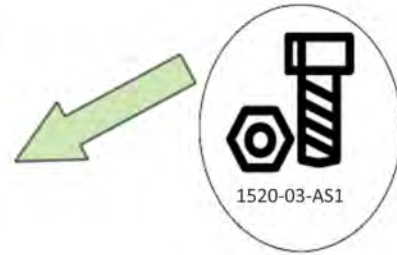

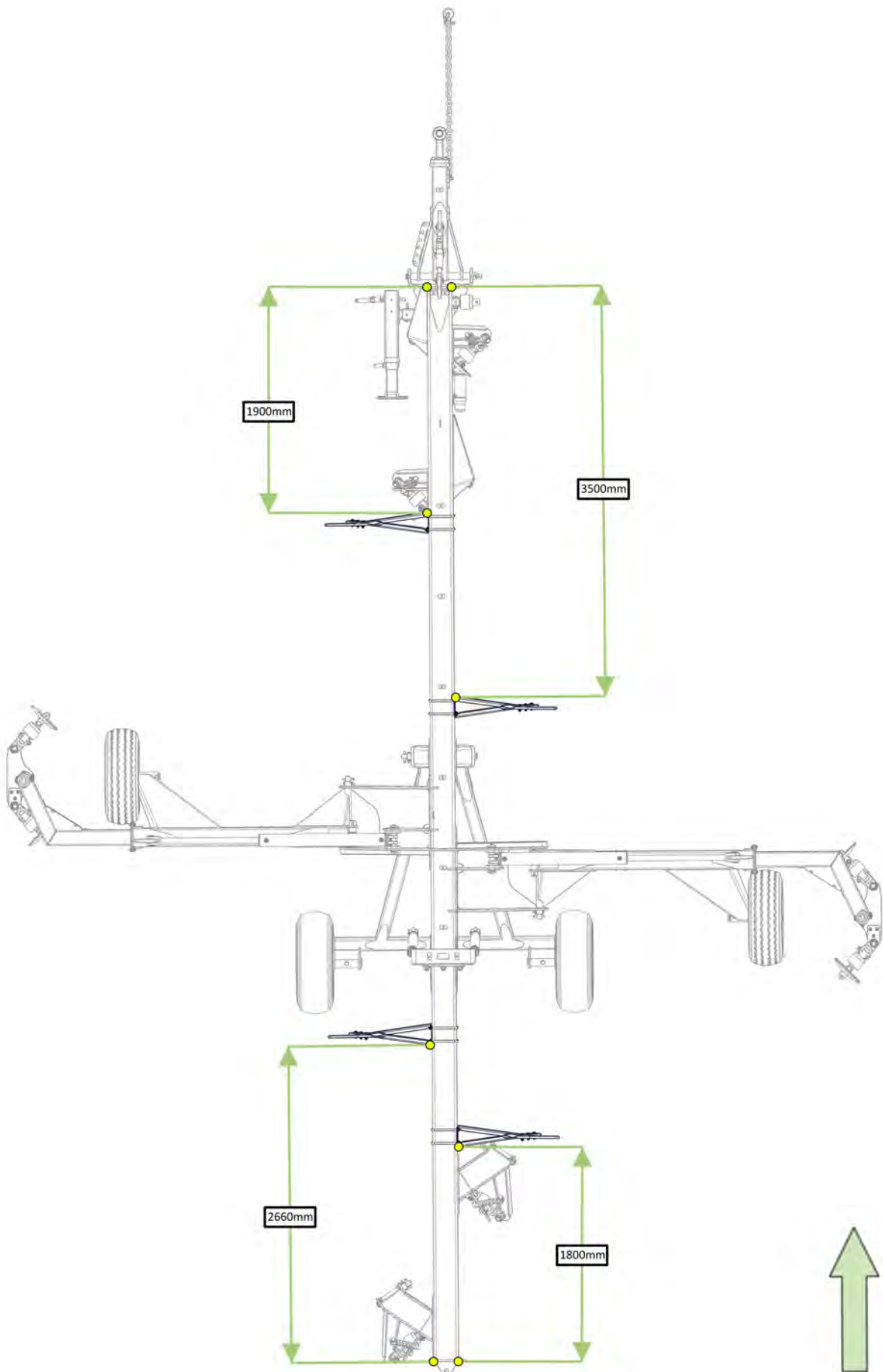

Item No.	Description	Qty	Number
1	M20 x 110 grade 10.9 ZP Short Thread Bolt	2	0211-20110 ST
2	Nyloc Nut M20	2	0221-NYL20
3	Disc Chain Spacer	2	0801-253755

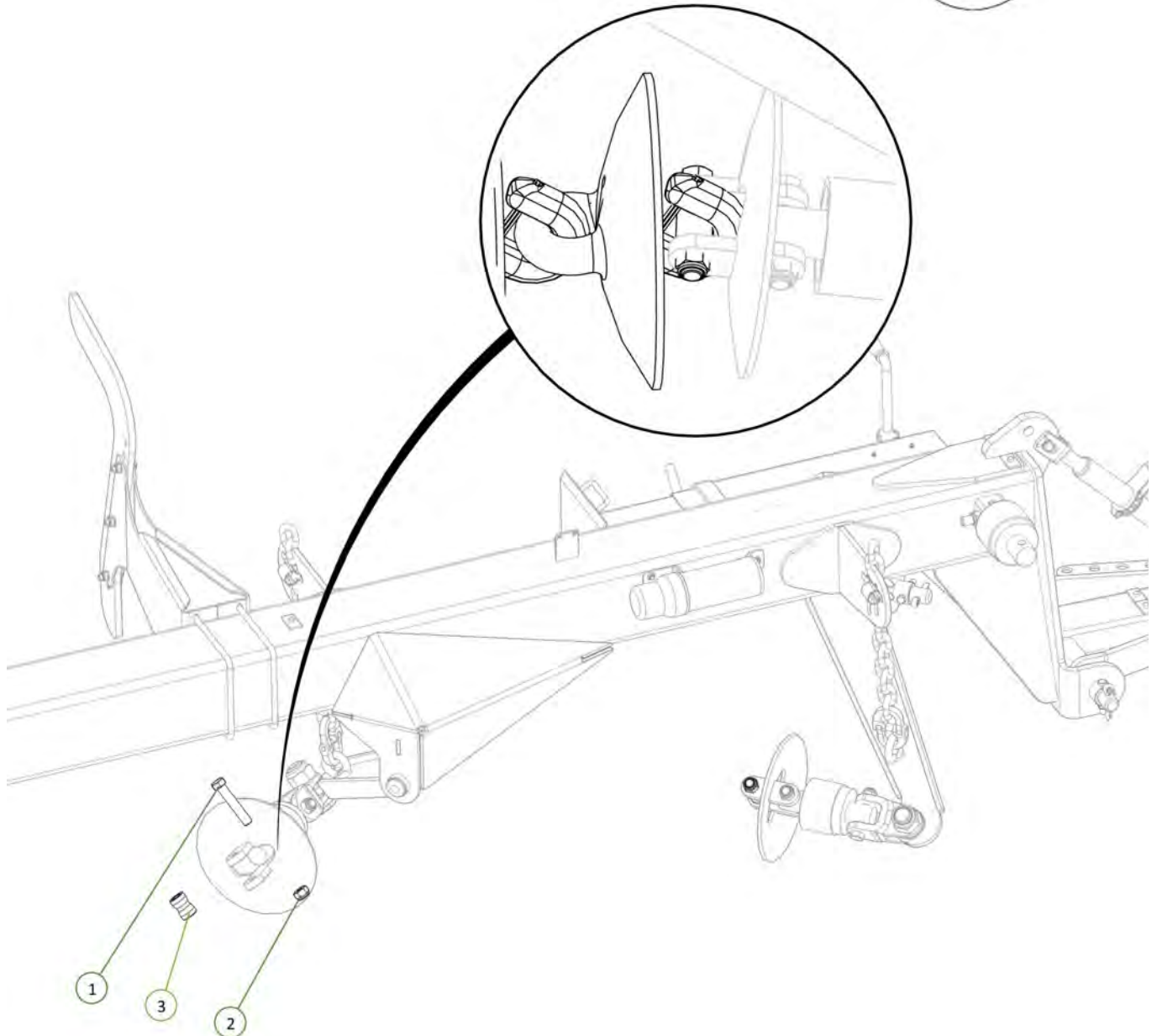

Item No.	Description	Qty	Number
1	Nyloc Nut M20	2	0221-NYL20
2	M20 x 110 grade 10.9 ZP Short Thread Bolt	2	0211-20110 ST
3	Disc Chain Spacer	2	0801-253755

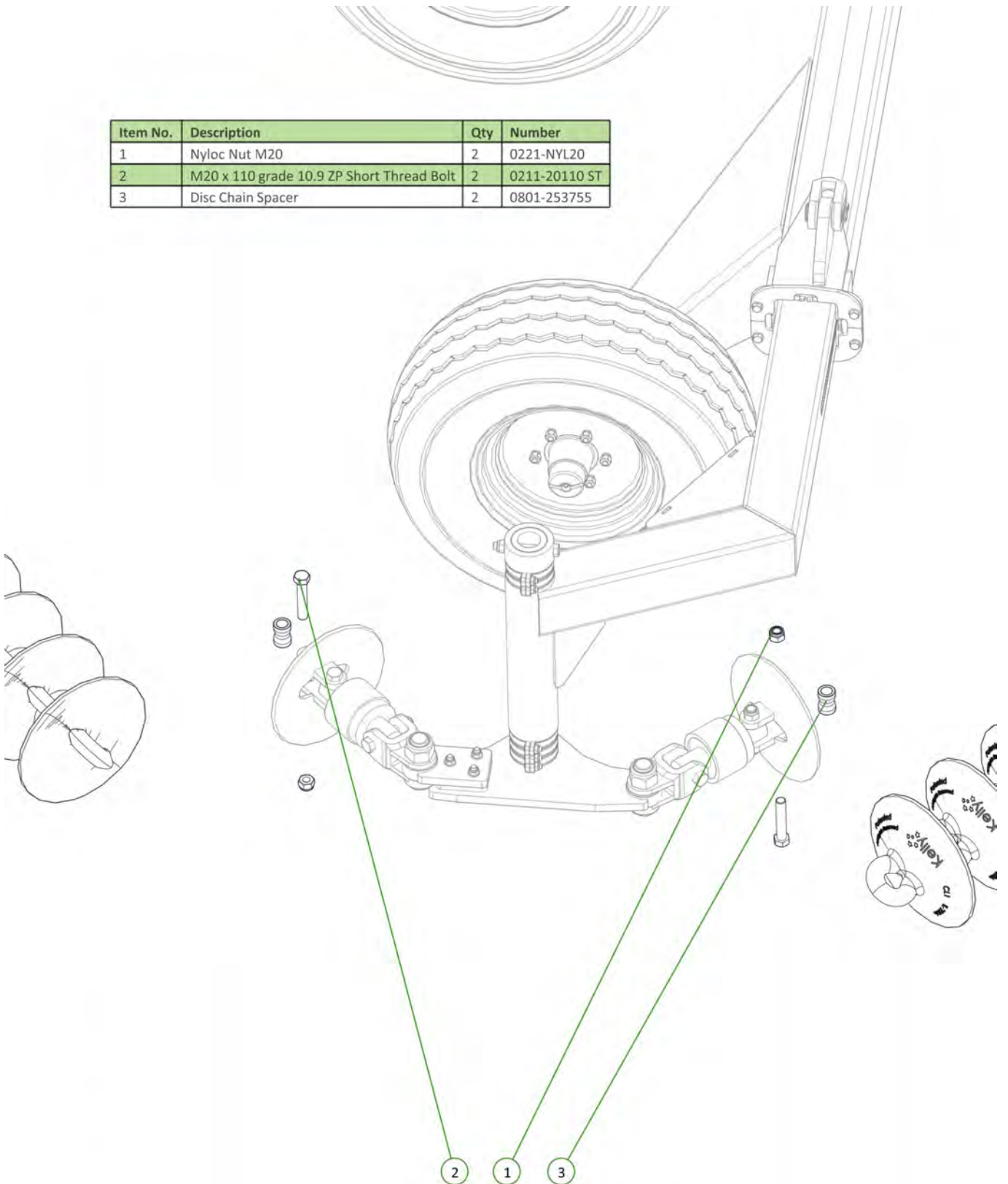

Item No.	Description	Qty	Number
1	M20 x 110 grade 10.9 ZP Short Thread Bolt	2	0211-20110 ST
2	Nyloc Nut M20	2	0221-NYL20
3	Disc Chain Spacer	2	0801-253755

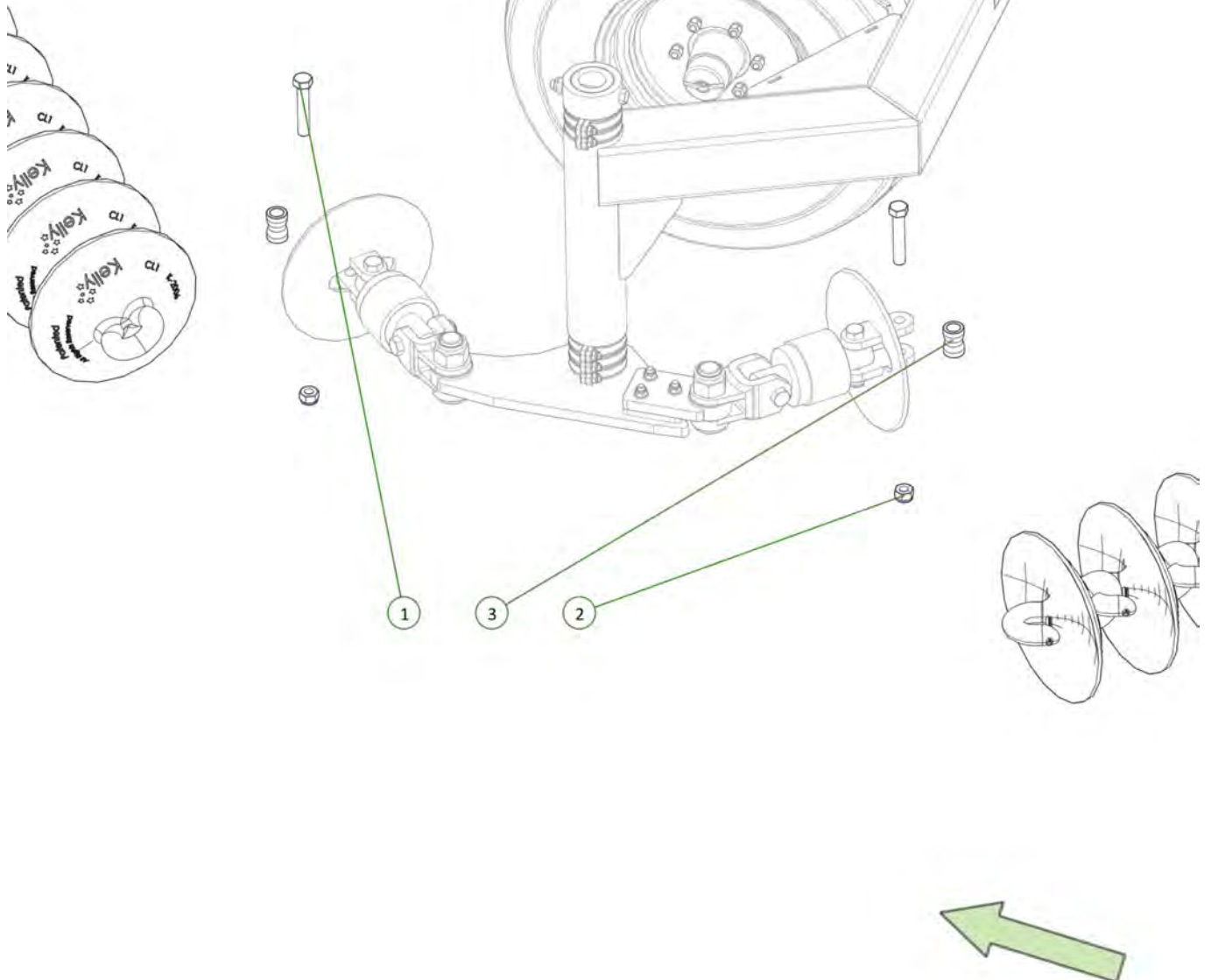

Item No.	Description	Qty	Number
1	Nyloc Nut M20	2	0221-NYL20
2	M20 x 110 grade 10.9 ZP Short Thread Bolt	2	0211-20110 ST
3	Disc Chain Spacer	2	0801-253755

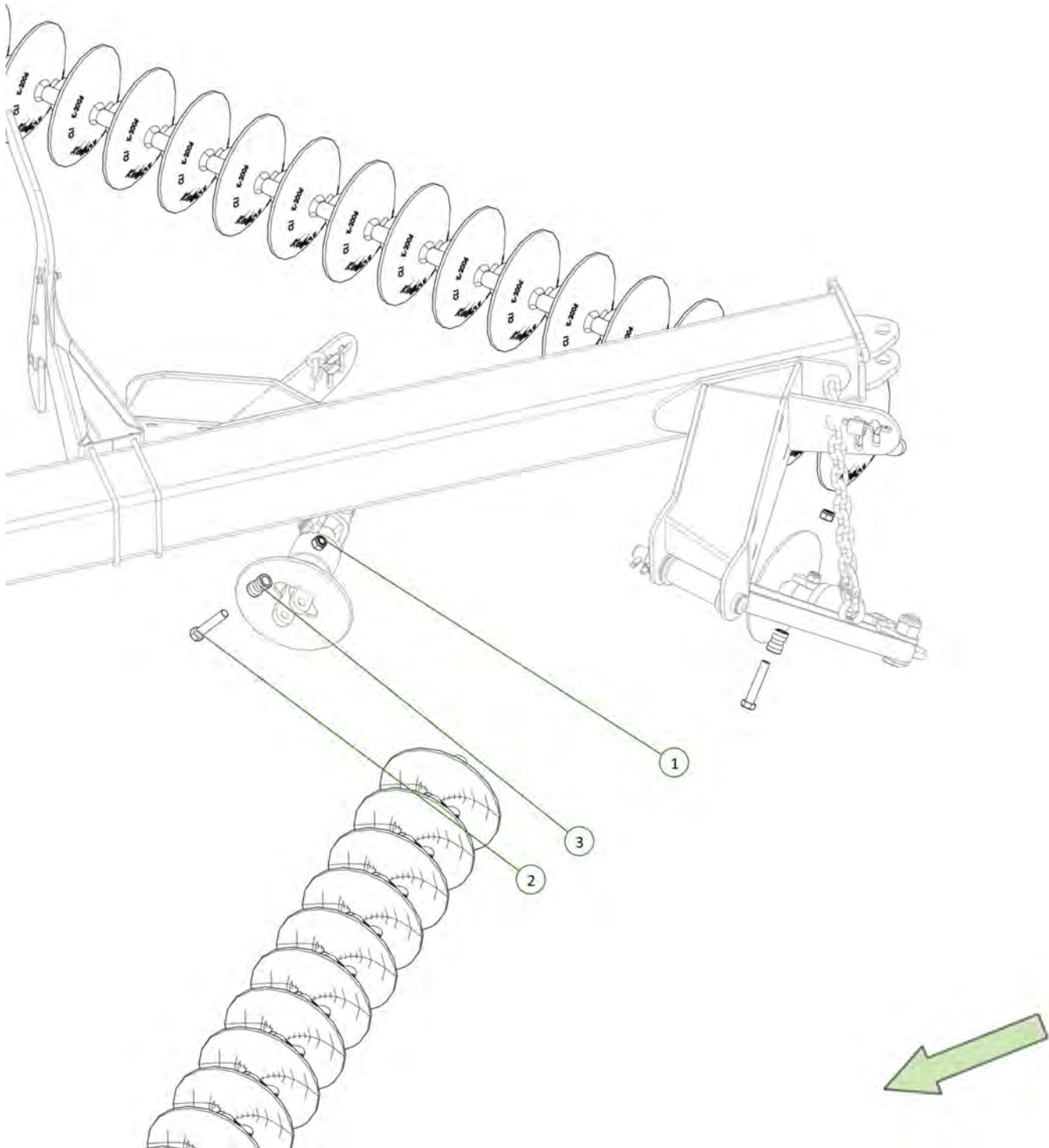

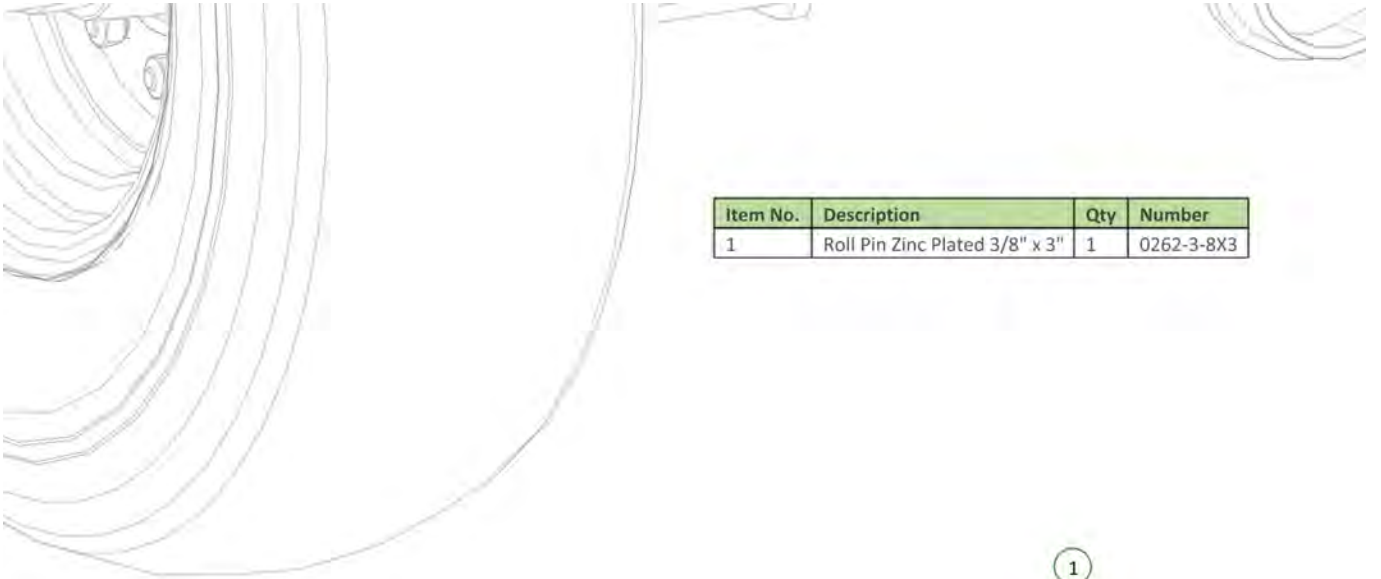

Item No.	Description	Qty	Number
1	Roll Pin Zinc Plated 3/8" x 3"	1	0262-3-8X3

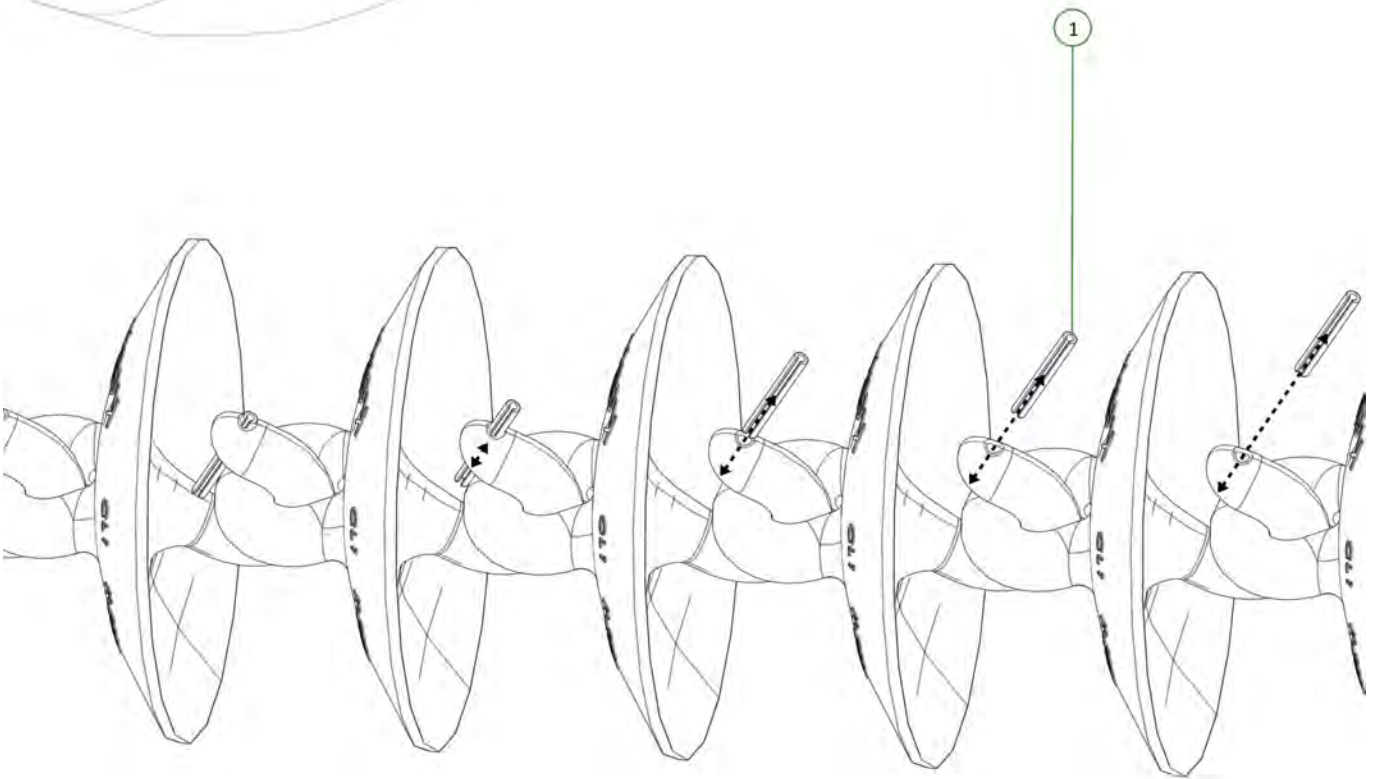

KELLY

Section 3 - Light Kit

Item No.	Description	Qty	Number
1	M5 x 0.8 x 15mm Grade 4.6 ZP Bolt	2	0211-515
2	M5 Spring Washer	2	0231-55
3	Wiring Capping Plate	1	1500-122
4	6M Light Kit EU	1	1502-EULK-6M

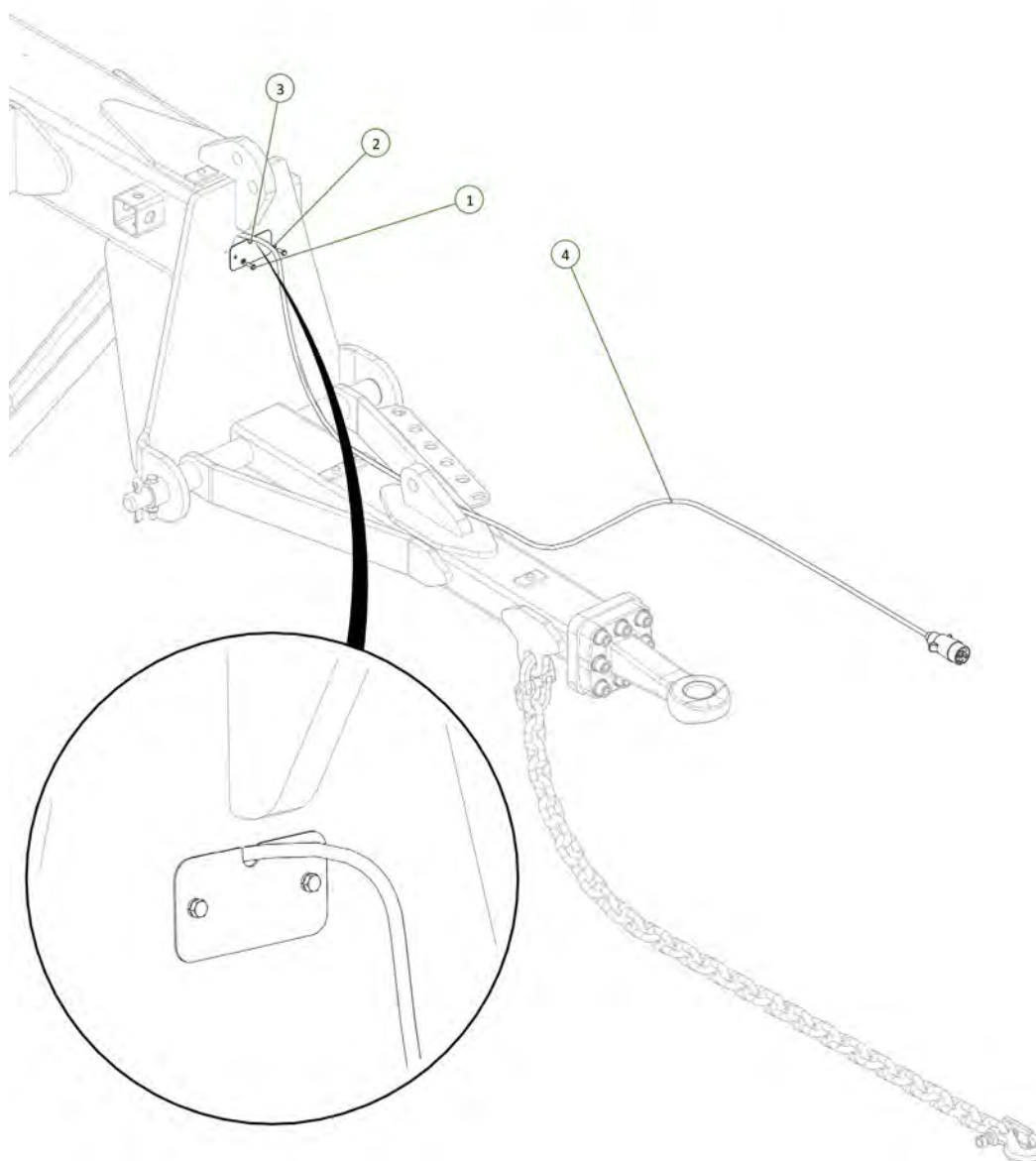

Item No.	Description	Qty	Number
1	M6 x 20mm Trilobe Screw	2	0211-M620MZPHTF
2	Wiring Capping Plate	1	1500-122

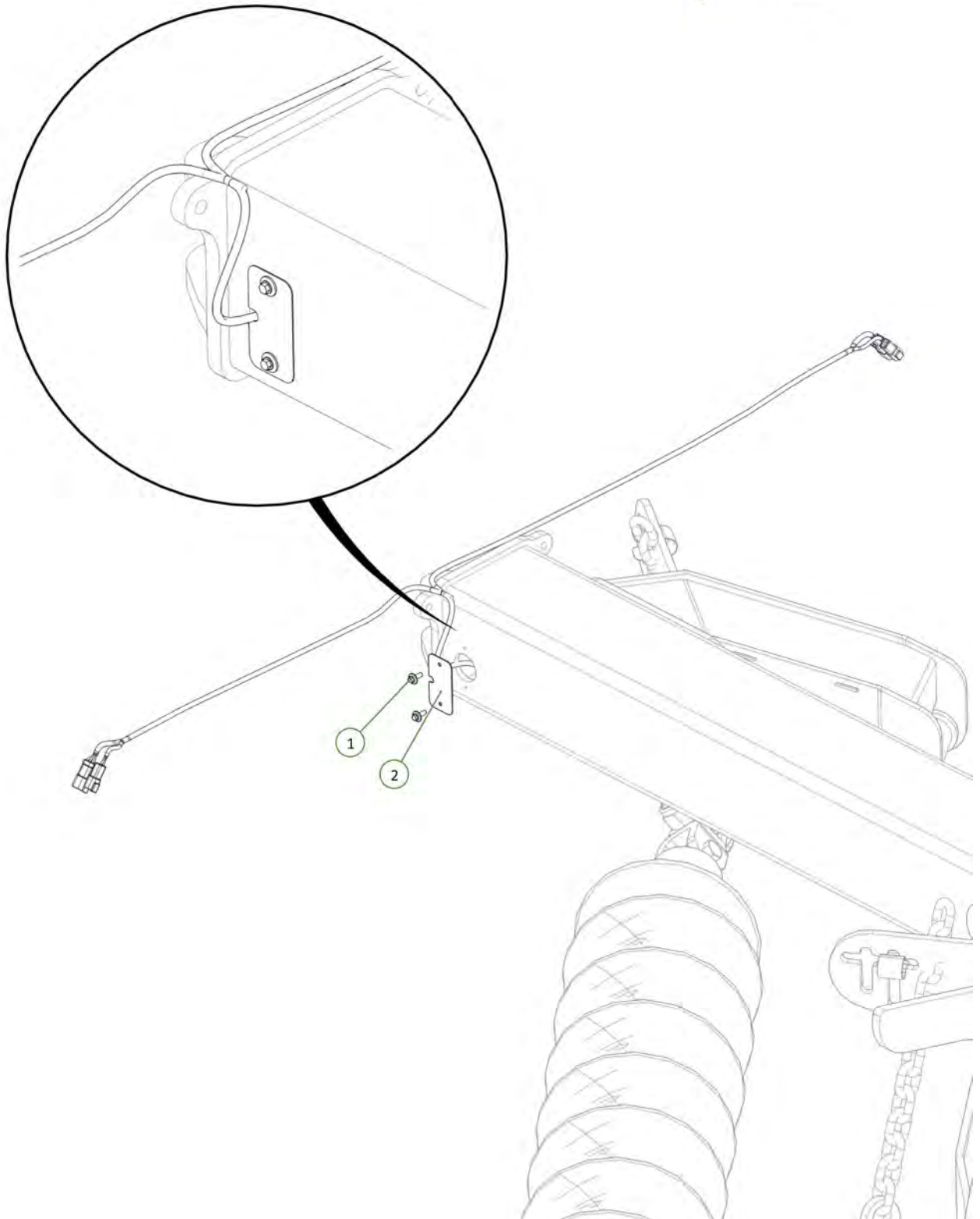

Item No.	Description	Qty	Number
1	Nyloc Nut M12	2	0221-NYL12
2	Sign and Light Bar	1	1510-27
3	M12 x 45 grade 8.8 ZP Bolt	2	0211-1245
4	Wiring capping plate	1	1500-122
5	M6 x 20mm Trilobe Screw	2	0211-M620MZPHTF

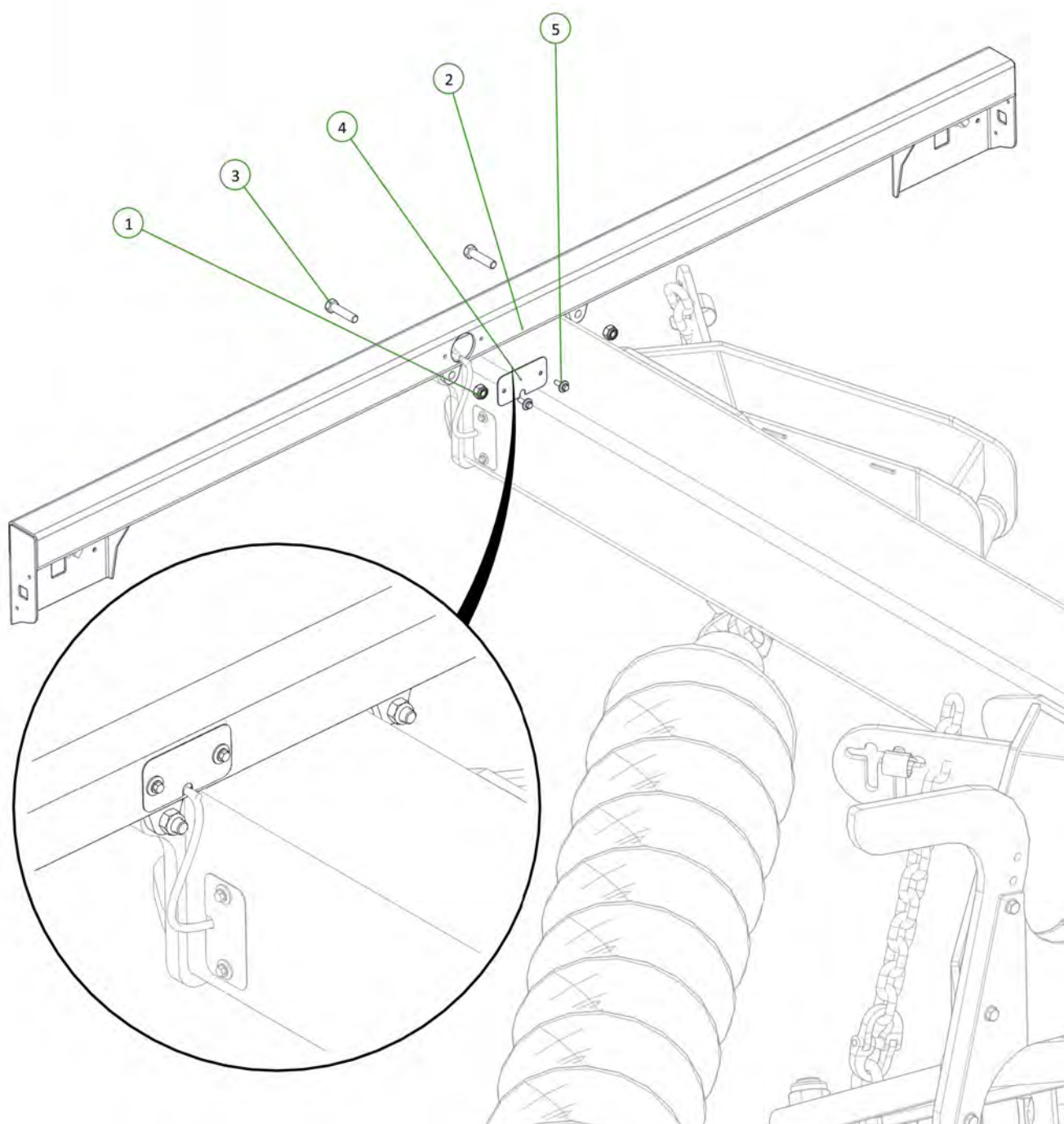
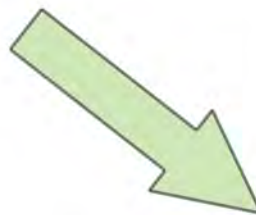

Item No.	Description	Qty	Number
1	LED Rubber Stalk Side Marker Lamp Right	1	0412-1004R
2	LED Rubber Stalk Side Marker Lamp Left	1	0412-1004L
3	LED Combination Tail Light Left	1	0412-EU200L
4	LED Combination Tail Light Right	1	0412-EU200R
5	Nyloc Nut M5	8	0221-NYL5
6	M5 x 0.8 x 20mm Grade 4.6 ZP Bolt	4	0211-520

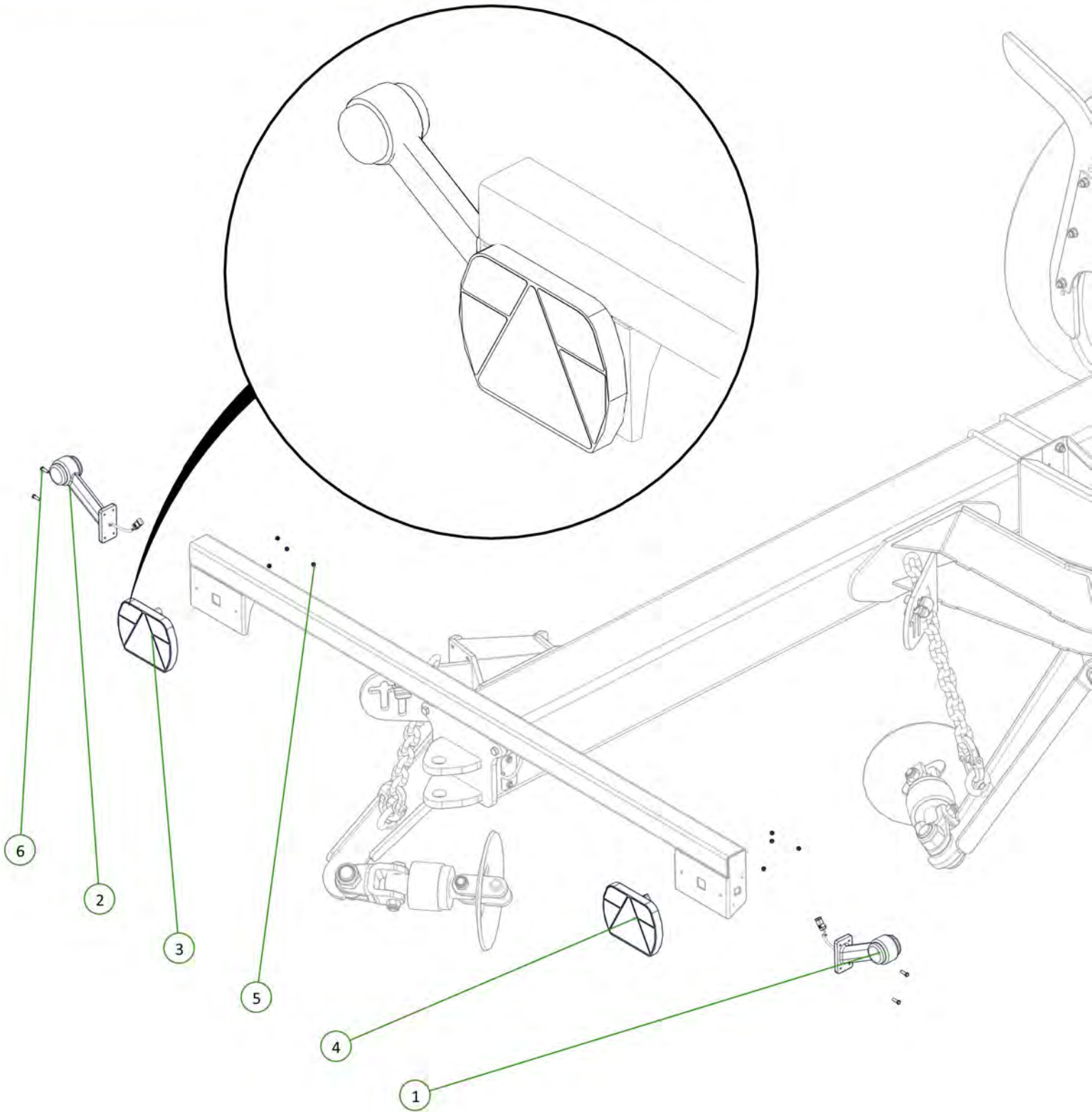

KELLY

Section 4 - Hydraulics

Item No.	Description	Number	Qty
1	3/4" JIC Male 3/4" UN O Ring Male 90° Elbow	0323-S91-1212	2
2	3/4" JIC Male 3/4" UN O Ring Male 45° Elbow	0323-S88-1212	2

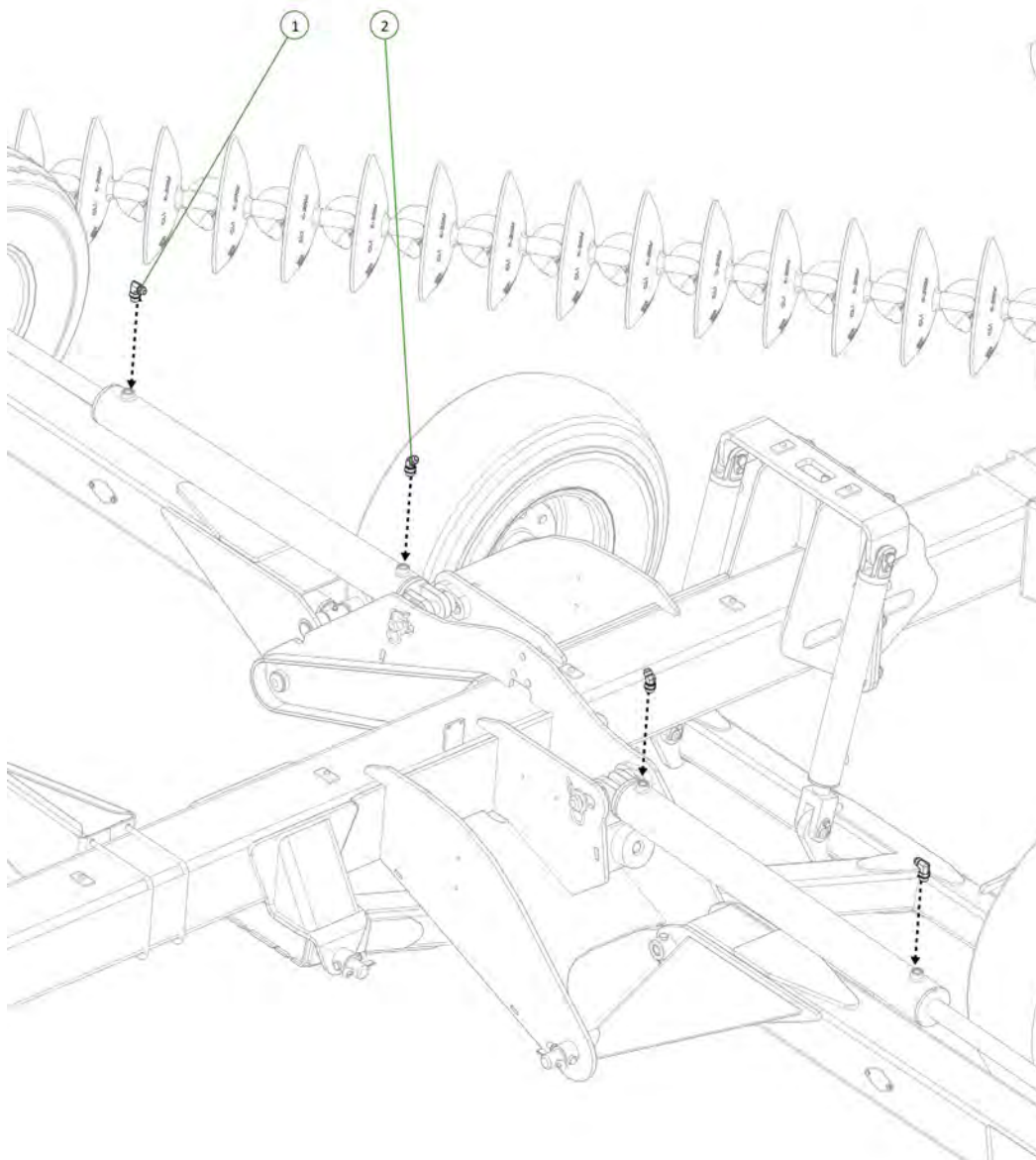
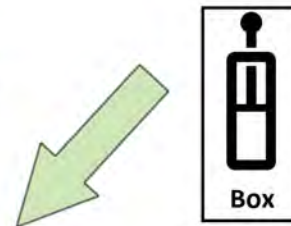

Item No.	Description	Number	Qty
1	3/4" JIC Male 3/4" UN O Ring Male 90° Elbow	0323-S91-1212	2

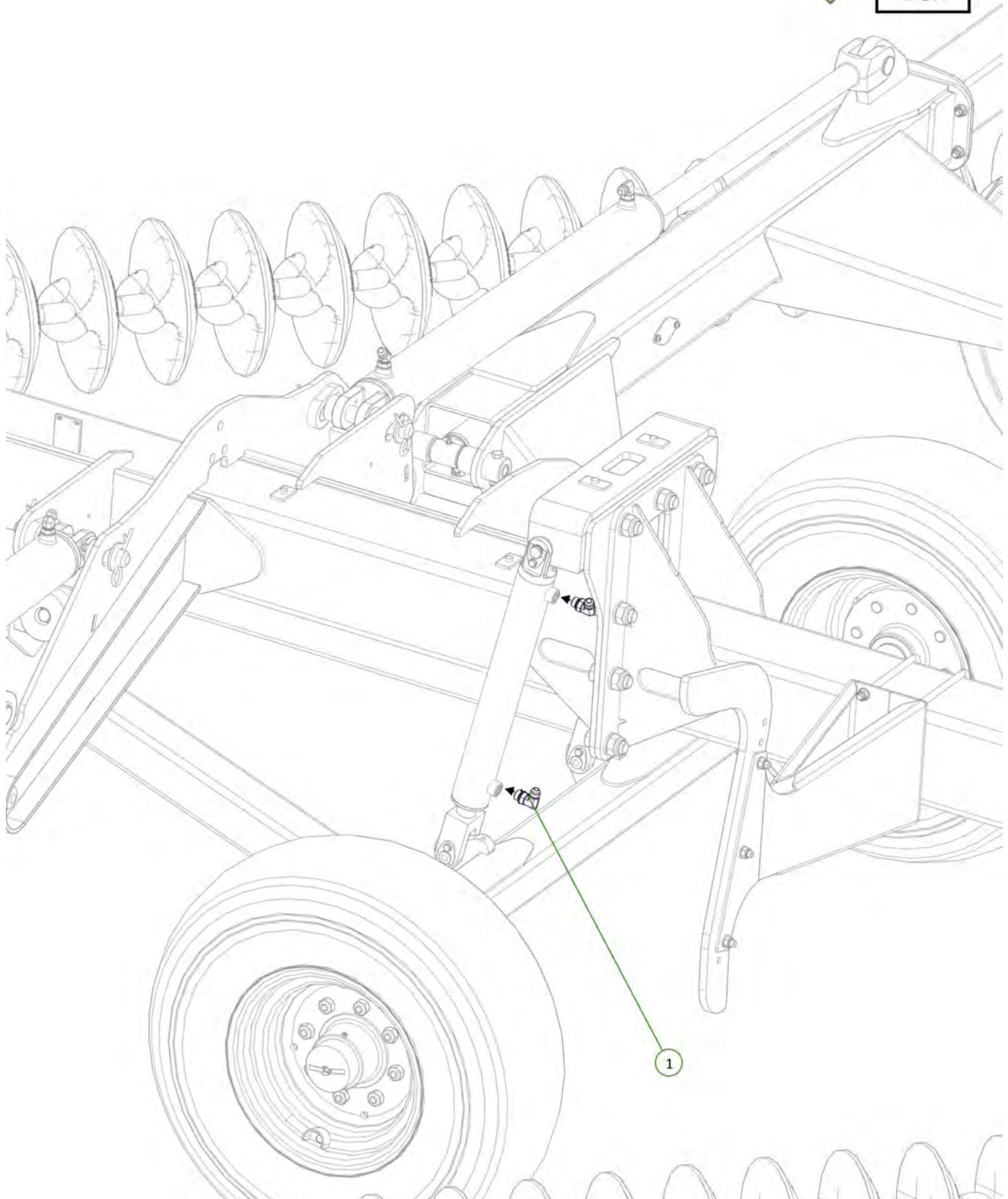

Item No.	Description	Number	Qty
1	3/4" JIC Male 3/4" UN O Ring Male 90° Elbow	0323-S91-1212	2

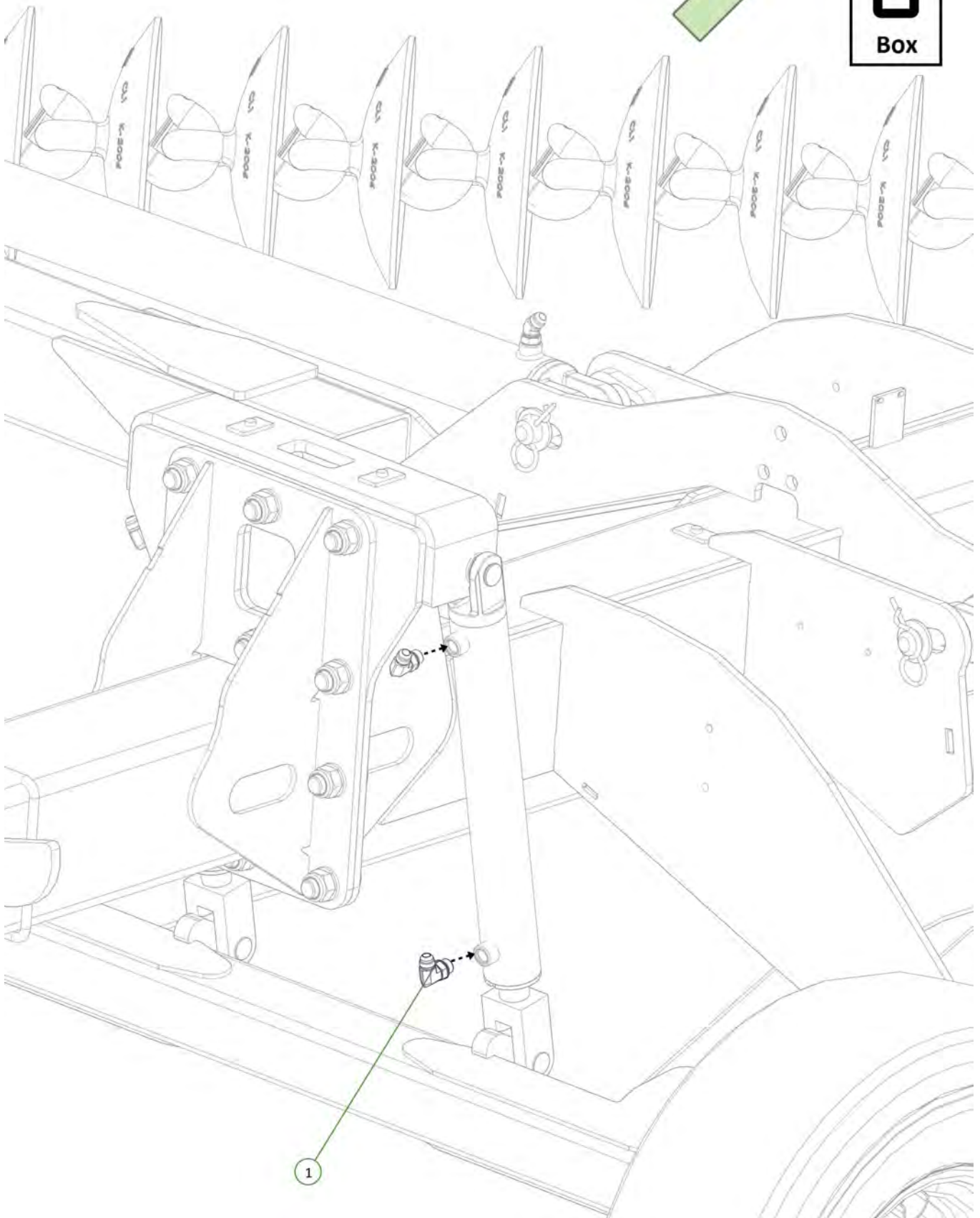

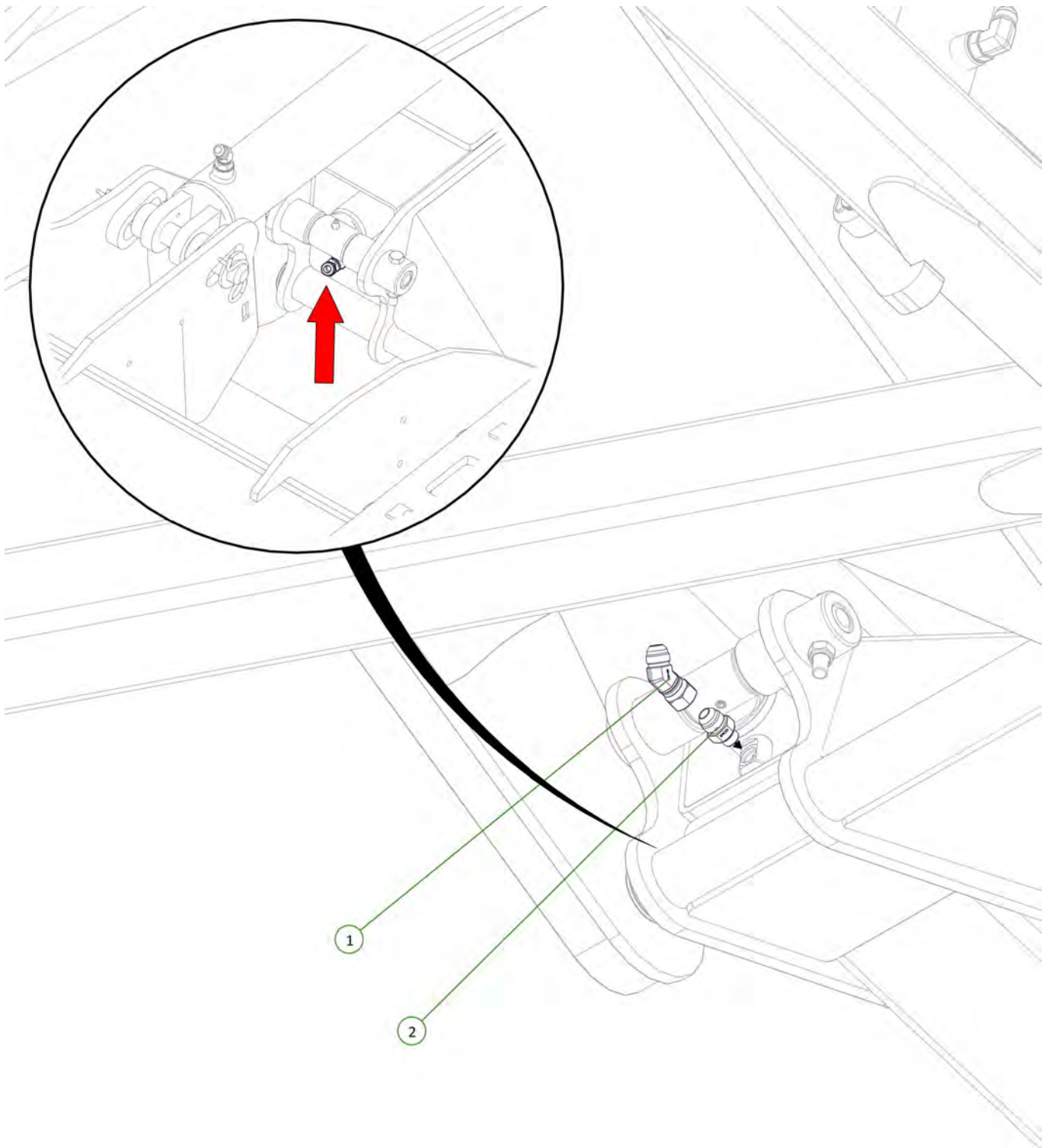

Item No.	Description	Number	Qty
1	3/4" JIC Male 3/4" JIC Female Swivel 45° Elbow	0323-S23-1212	1
2	3/4" JIC Male 9/16" UN O Ring Male Adaptor	0323-S90-1209	1

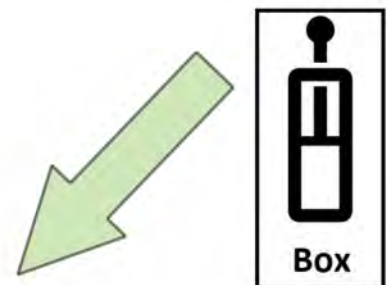

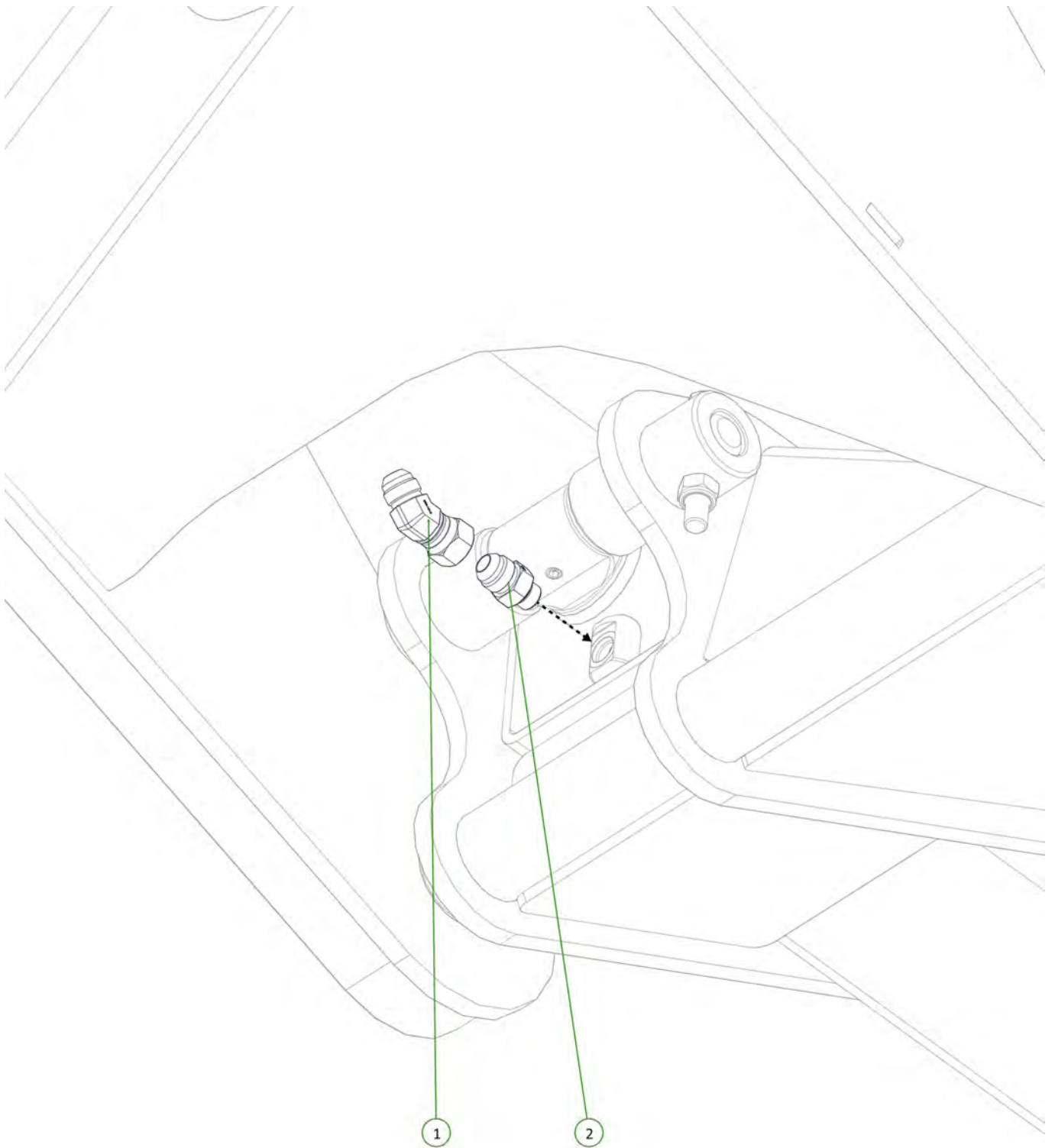

Item No.	Description	Number	Qty
1	3/4" JIC Male 3/4" JIC Female Swivel 45° Elbow	0323-S23-1212	1
2	3/4" JIC Male 9/16" UN O Ring Male Adaptor	0323-S90-1209	1



Item No.	Description	Number	Qty
1	Ball Valve BSPP 1/2"	0341-RL20SH-0808	2
2	1/2" BSPP Encapt Male 3/4" JIC Male Adaptor	0323-S74-0812	4
3	M6 Class 8.8 ZP Bolt	0211-685	2
4	Nyloc Nut M6	0221-NYL6	2

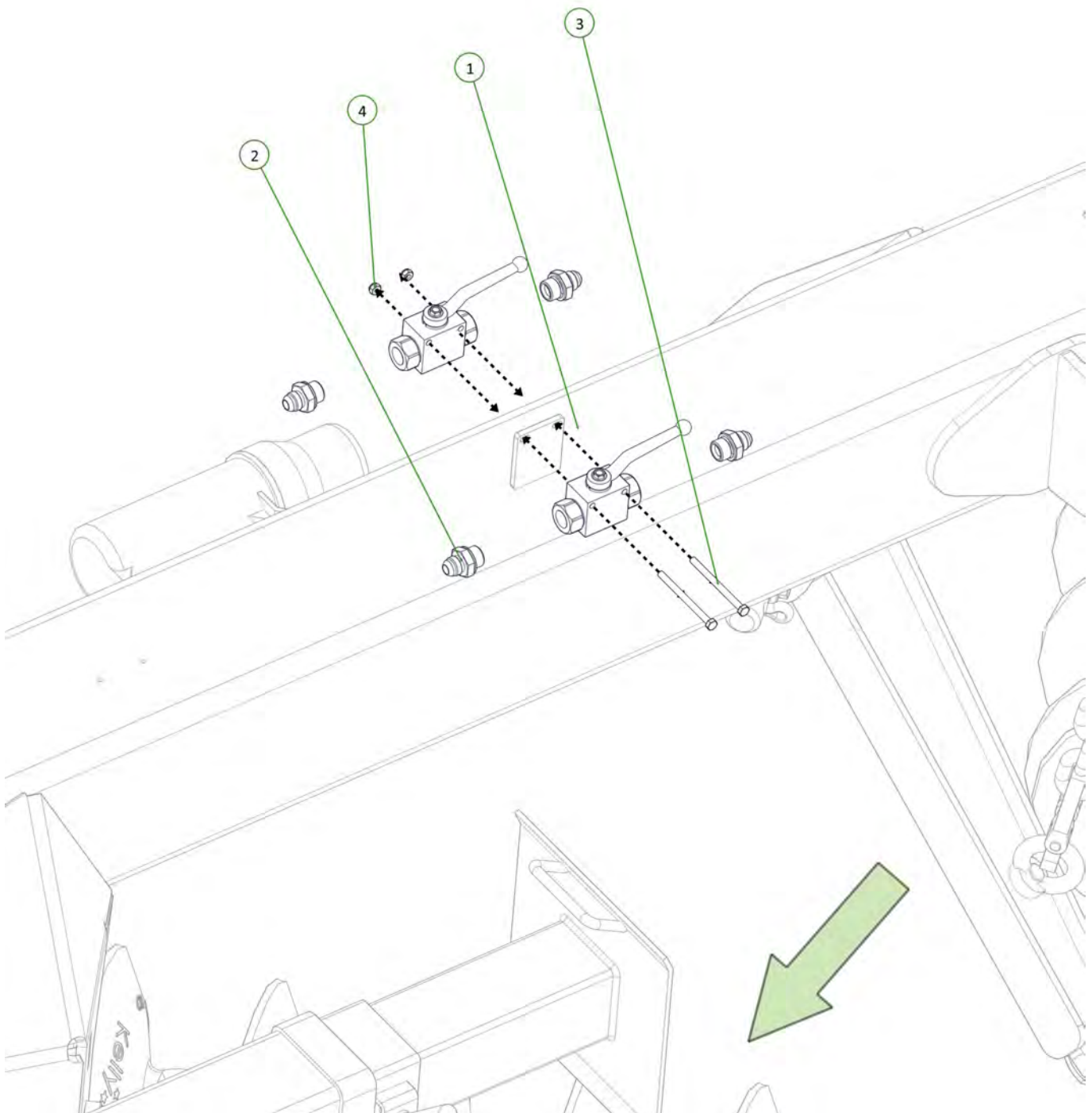
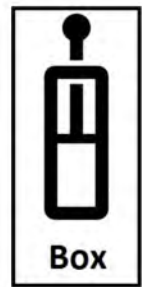
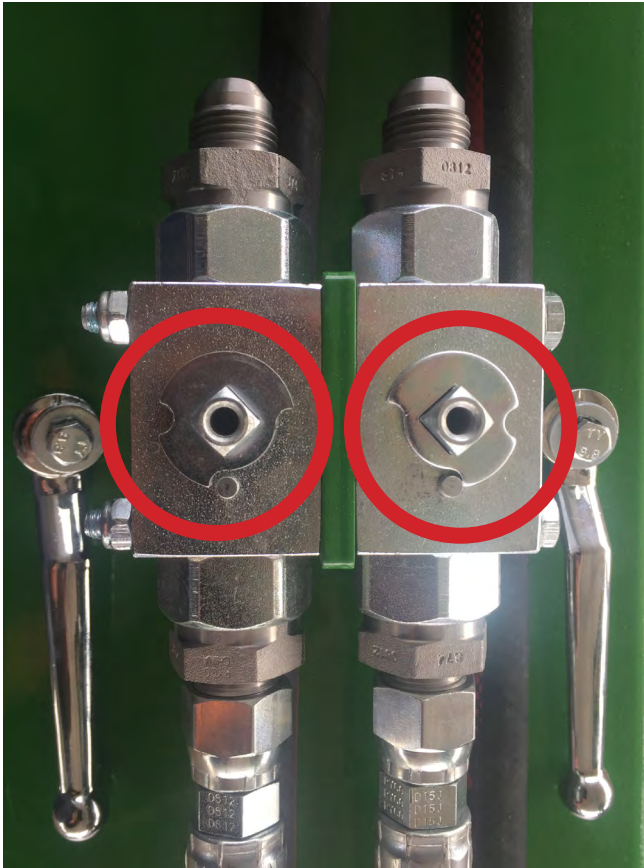

Image 1



Please Note -

1. Unbolt tap handle from tap (as seen in image 1).
2. Flip one plate over so they are a mirror image (as seen in image 1).
3. Bolt tap handle back in original position (as seen in image 2)
4. Correct fitment will ensure taps are closed when both facing outwards on the machine (as seen in image 3).

Image 2



Image 3



Item No.	Description	Number	Qty
1	M6 x 50 Class 8.8 ZP Bolt	0211-650	2
2	Washer Spring M6	0231-S6	2
3	Washer Flat M6	0231-F6	2
4	3/4" JIC Male 3/4" UN O Ring Male 3/4" JIC Male Tee	0324-S87-121212	1
5	3/4" JIC Male 3/4" UN O Ring Male 90° Elbow	0323-S91-1212	1
6	Pressure Reducing/Relieving Valve Cartridge	0341-PR50-36A0P30	1
7	10-Size 3-Way Valve Housing	0341-7024380	1

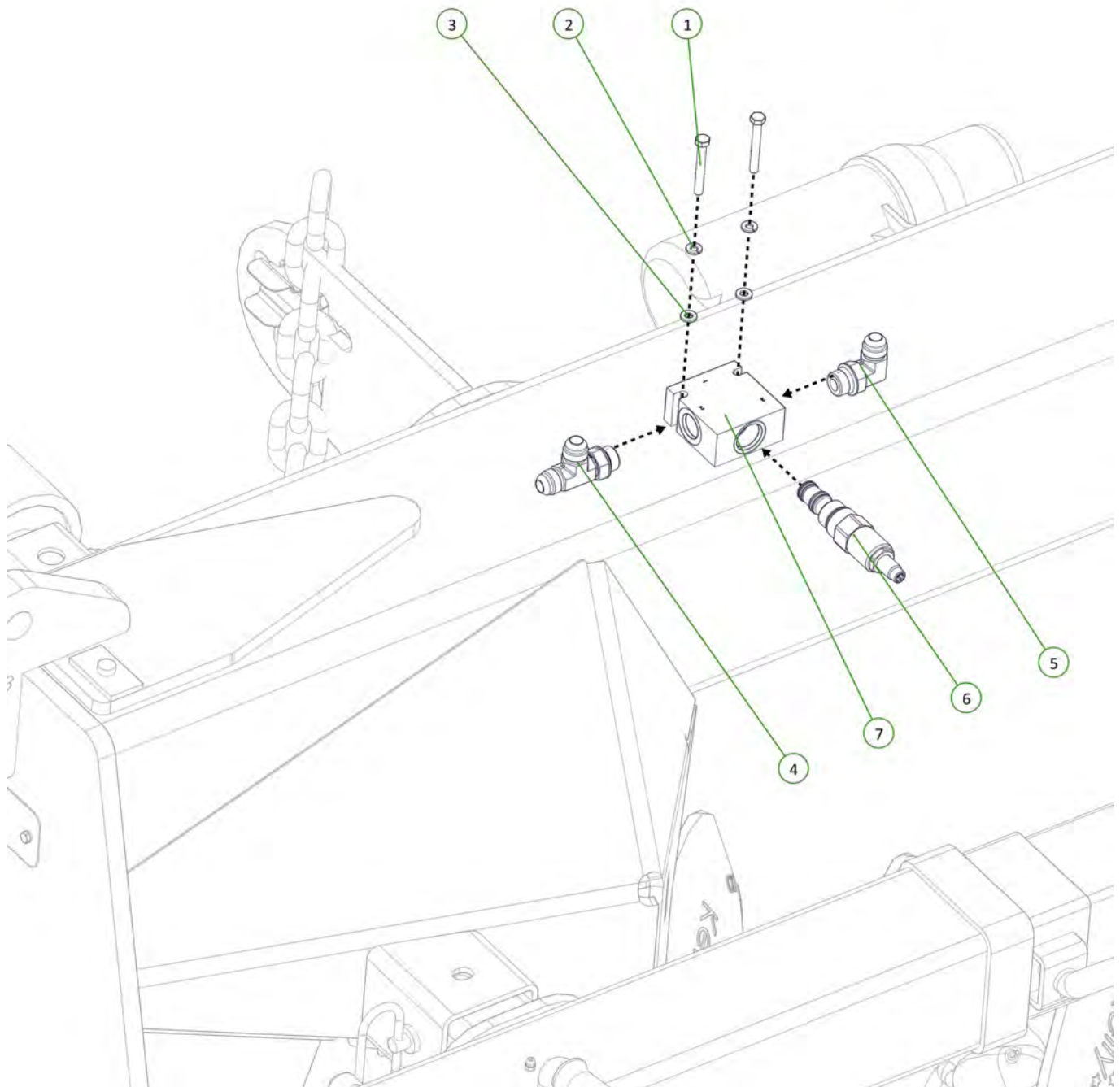
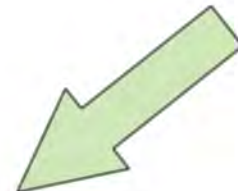
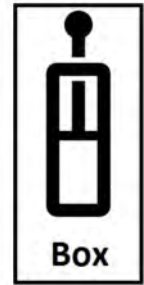
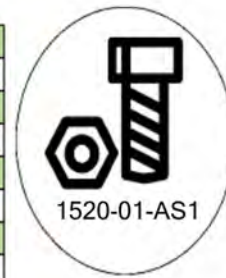

Item No.	Description	Number	Qty
1	3/4" JIC Female Nut & Sleeve	0323-S6-1208	2
2	3/4" JIC Female Swivel 3/4" UN O Ring Male Adaptor	0323-S101-1212	1
3	3/8" BSPP Encapt Male 3/4" JIC Female Swive Adaptor	0323-S71-0612	1
4	3/8" BSPP O Ring Male 3/4" JIC Male 90° Elbow	0323-S76-0612	1
5	7/8" JIC Male 7/8" JIC Male 7/8" JIC Female Tee	0324-S68-121212	2
6	Accumulator Valve Connection Pipe 2	0323-ACCUM-VALVE-P2	1
7	In Line Check Valve BSPP	0341-RCV-0606	1
8	3/4" JIC Male Tee 3/4" JIC Male Tee 3/4" JIC Male Tee	0324-S19-121212	1

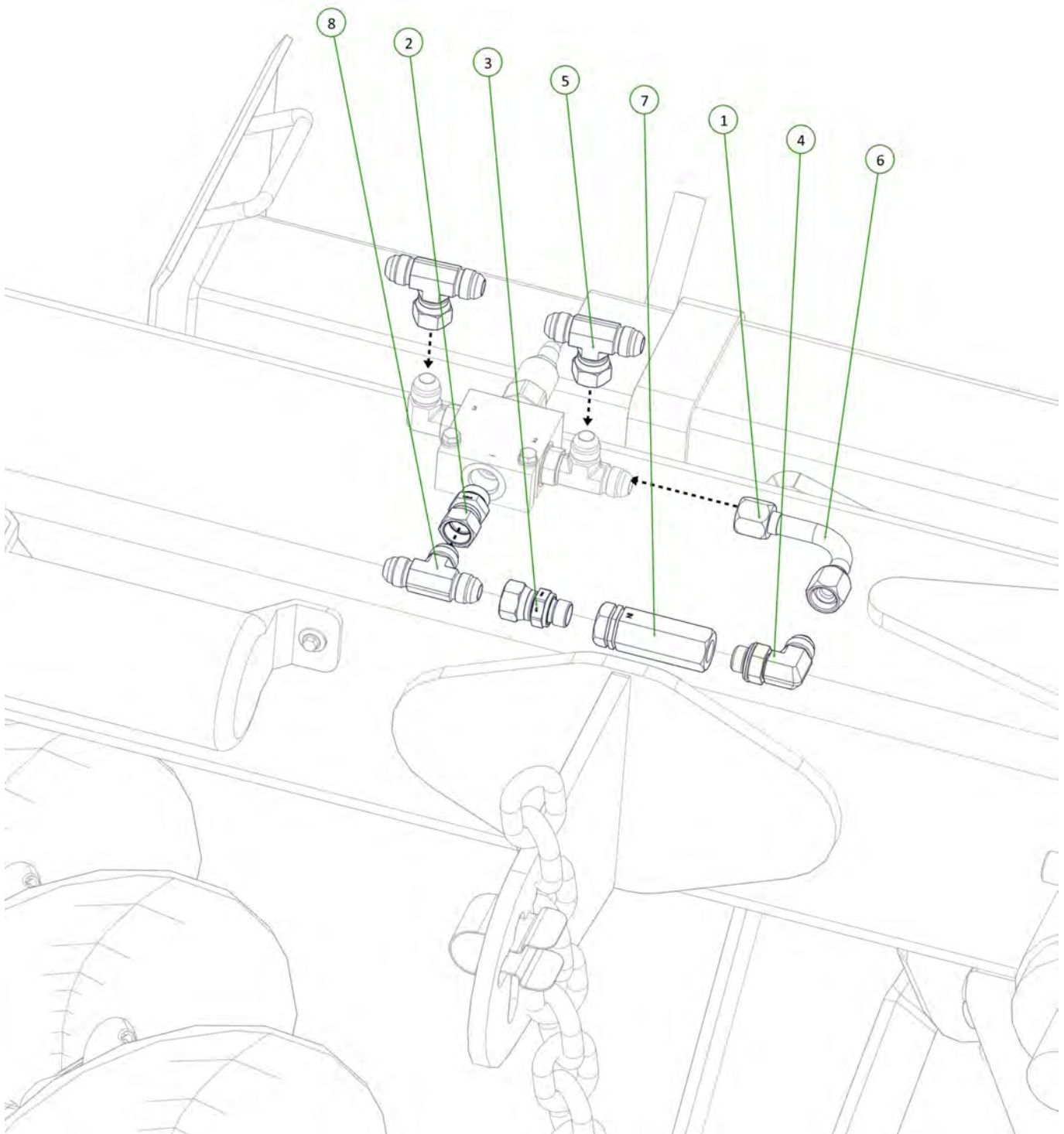

Item No.	Description	Number	Qty
1	M8 x 30 Class 8.8 ZP Bolt	0211-830	2
2	Nyloc Nut M8	0221-NYL8	2
3	Washer Flat M8	0231-F8	4
4	Accumulator Clamp 143-151	0343-ACCUCLAMP-143-151	1

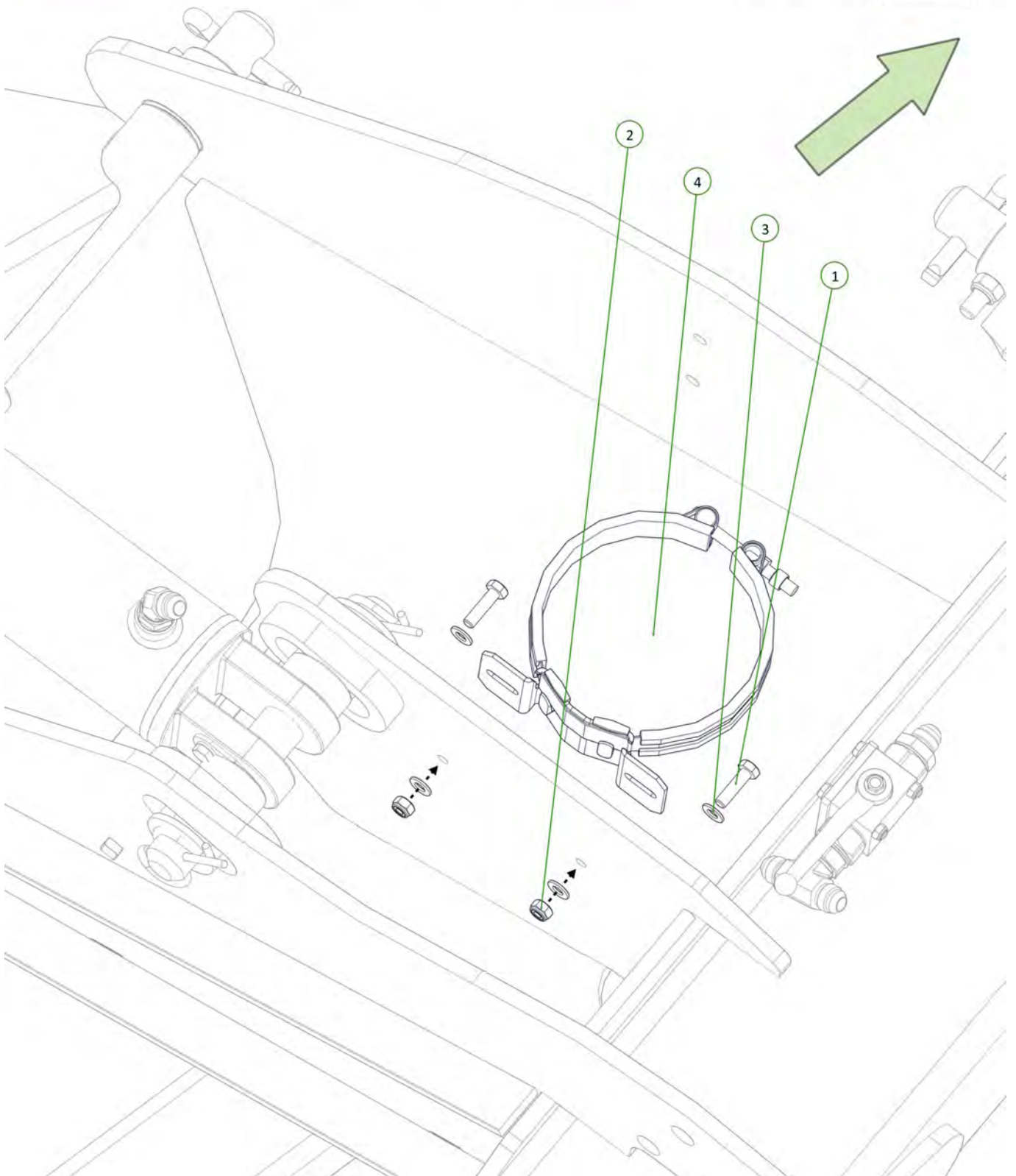
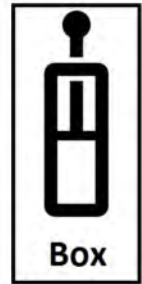

Item No.	Description	Number	Qty
1	3/4" JIC Male 3/4" JIC Male 1/2" BSPP O Ring Male Tee	0324-S79-121208	1
2	Bladder Accumulator 1.4L	0343-SBO210-1.4EI	1

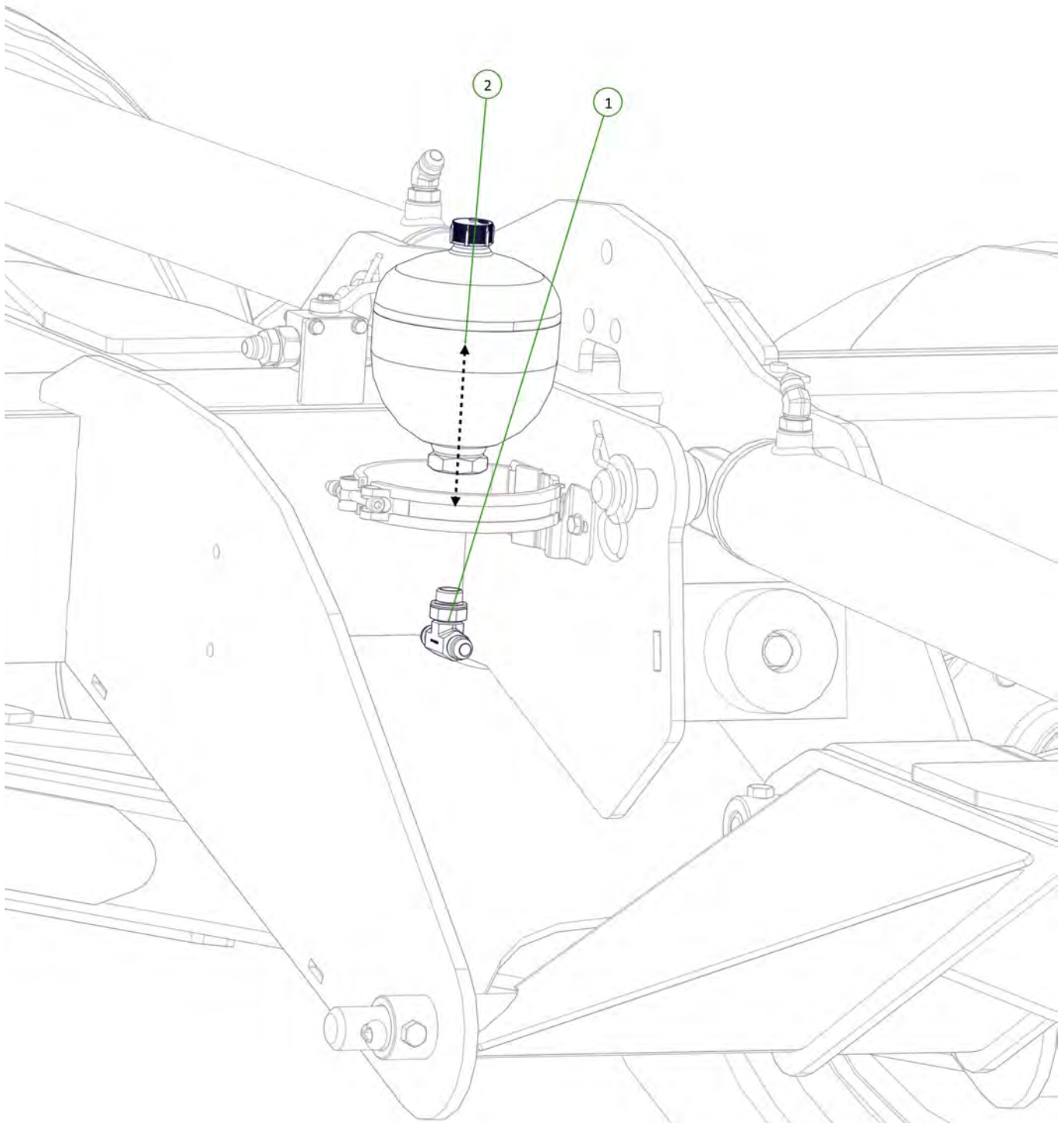
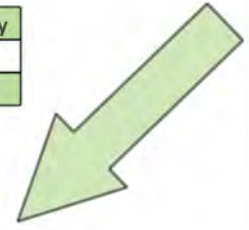

Item No.	Description	Number	Qty
1	RCD Double Clamp Jaws 17mm	0325-RCD-17J	3
2	Double Clamp Stacking Plate (Non Ryco)	0325-SI-2-5D-W3	2
3	RCD Double Clamp Stacking Bolt No 2	0325-RCD-2BS	2
4	RCD Double Clamp Bolt No 2	0325-RCD-2BH	1
5	RCD Double Clamp Top Plate No 2	0325-RCD-2PT	1

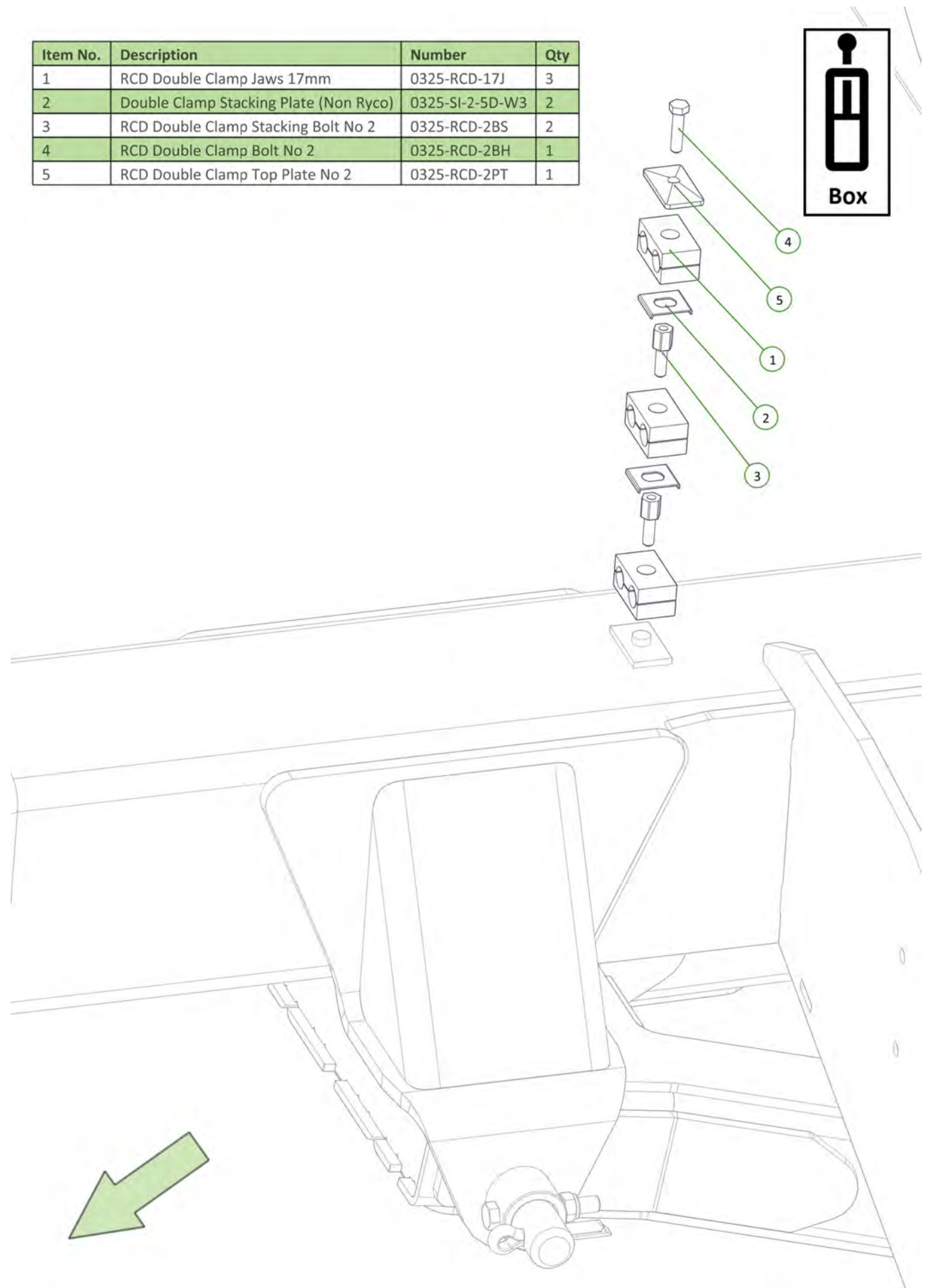

Item No.	Description	Number	Qty
1	Tractor to Main Pressure Relief Extend Fitted with Green Extend Grip	H6-02-GE	1
2	Stucchi 1/2" NPT QRC Ball Male Tip	0325-M-IR12MNPT	1

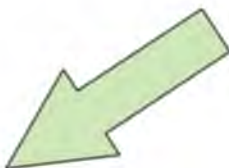
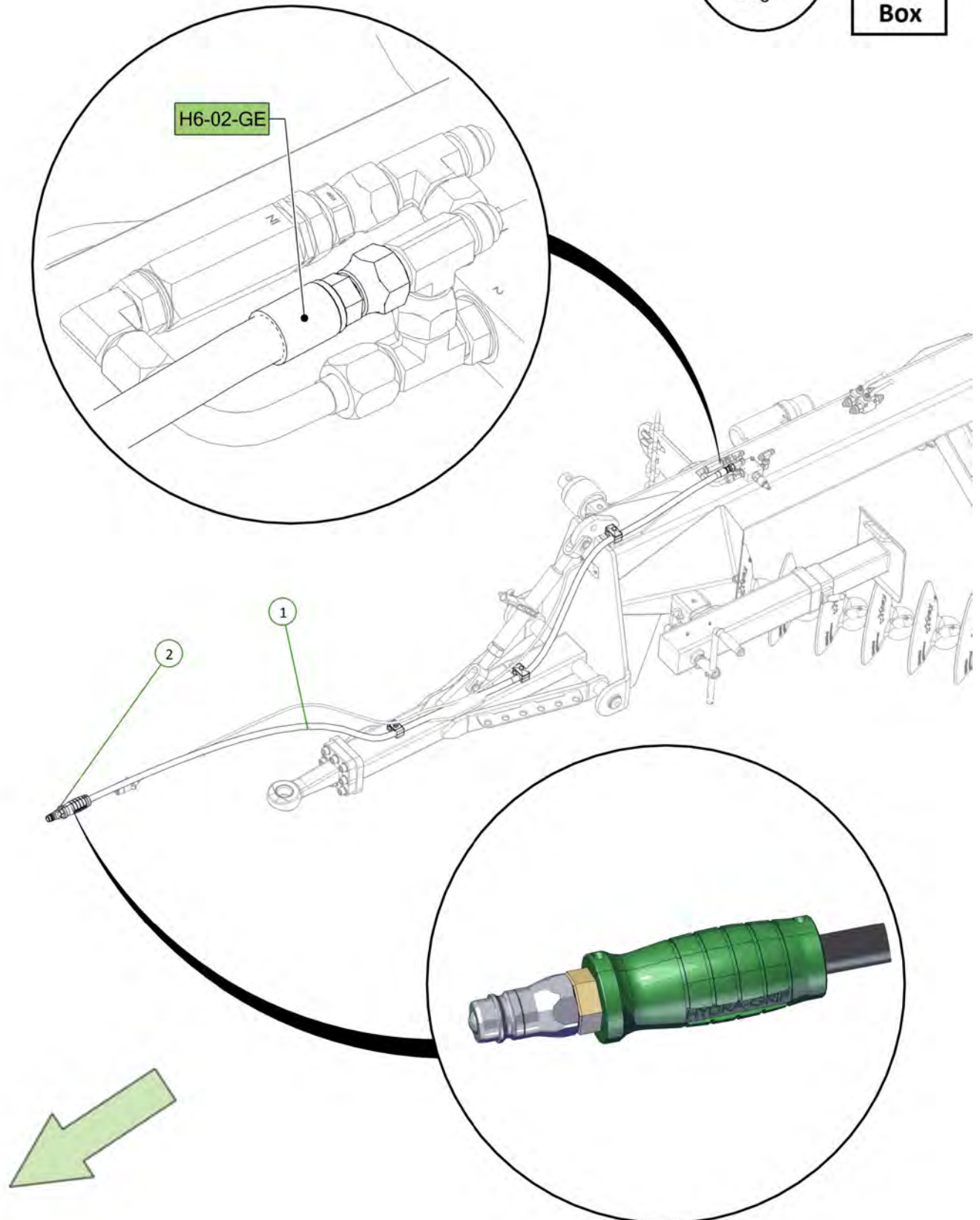
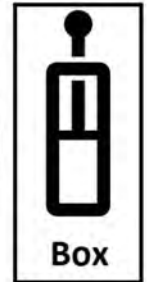

Item No.	Description	Number	Qty
1	Tractor to Wheel Retract Fitted with Yellow Retract Grip	H6-11-YR	1
2	Stucchi 1/2" NPT QRC Ball Male Tip	0325-M-IR12MNPT	1

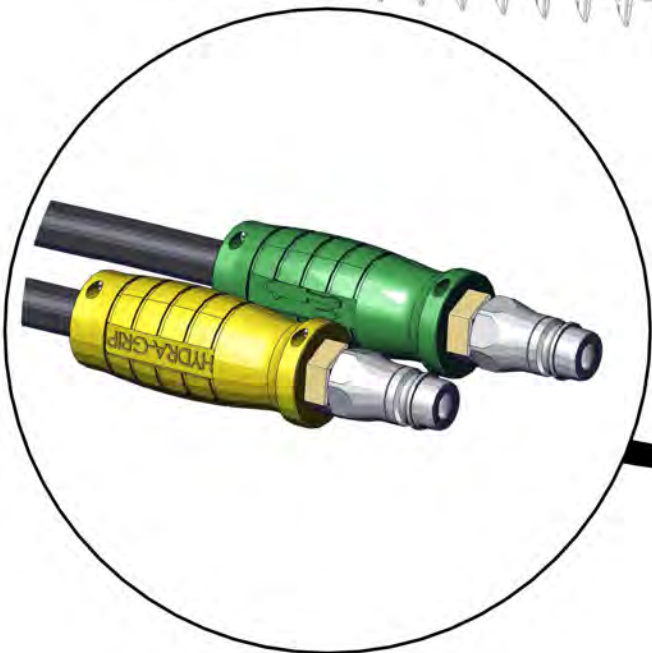
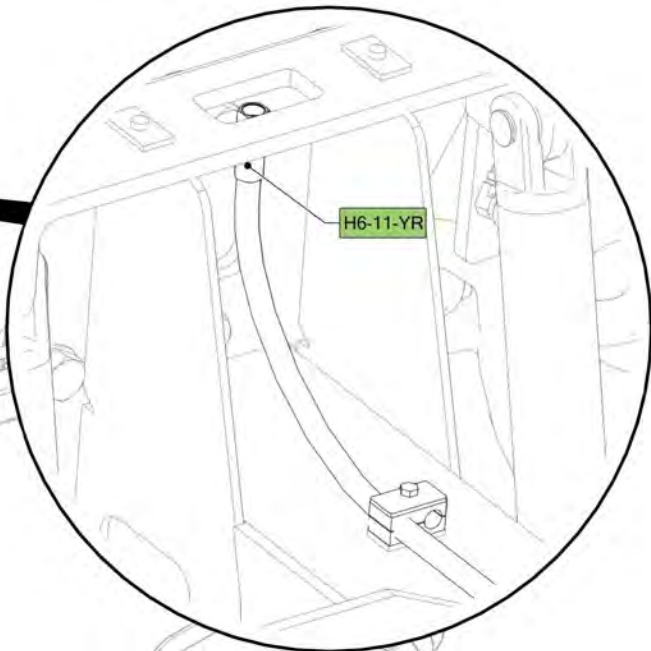
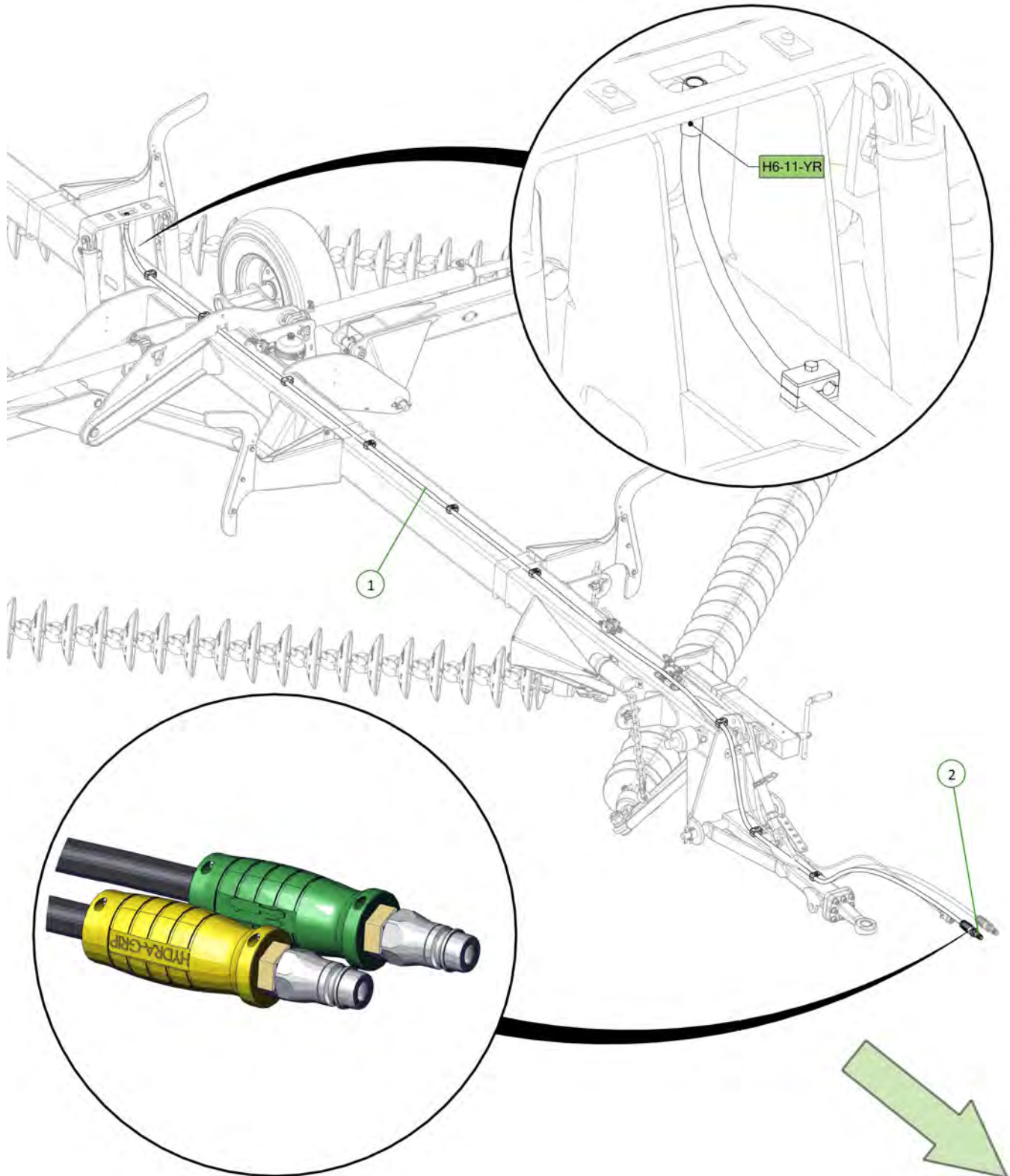

Item No.	Description	Number	Qty
1	Tractor to Pressure Relief Valve Retracted with Green Retracted Grip	H6-03-GR	1
2	Stucchi 1/2" NPT QRC Ball Male Tip	0325-M-IR12MNPT	1

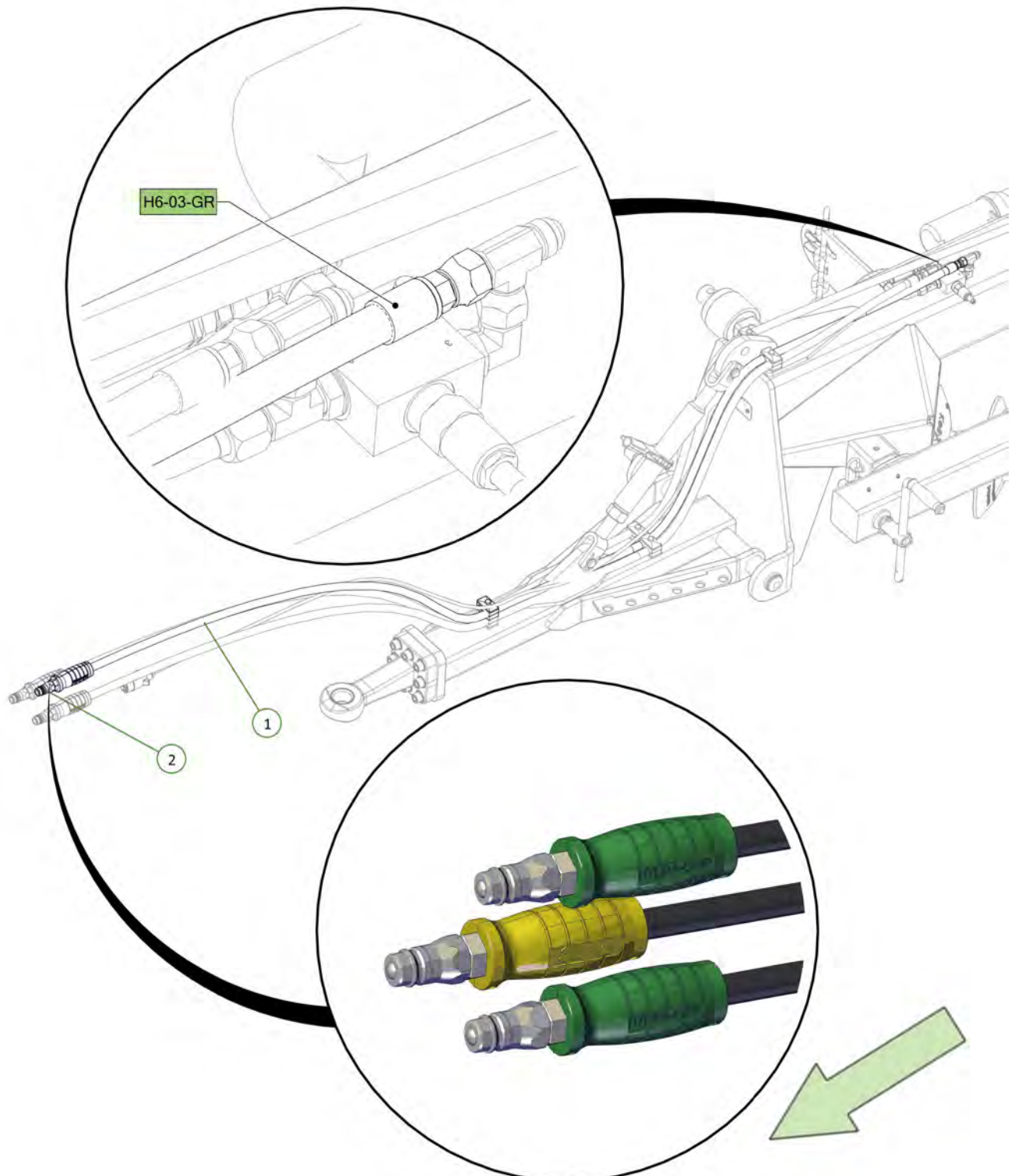
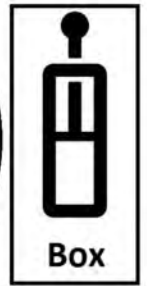

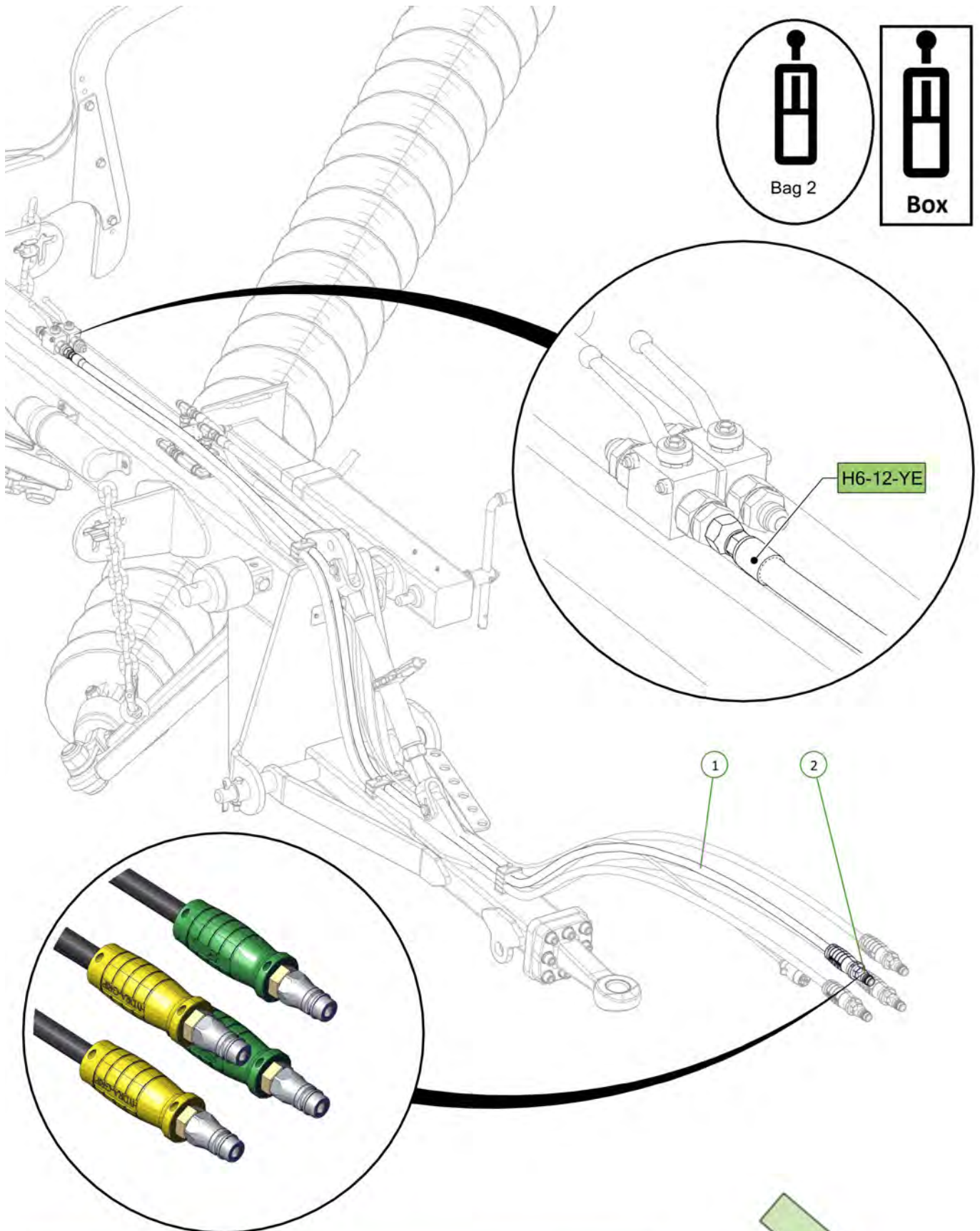
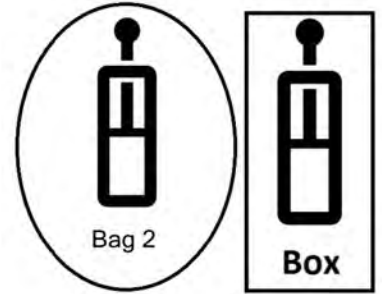

Item No.	Description	Number	Qty
1	Tractor to Whel Lift Tap Extend Fitted With Yellow Extend Grip	H6-12-YE	1
2	Stucchi 1/2" NPT QRC Ball Male Tip	0325-M-IR12MNPT	1



Item No.	Description	Number	Qty
1	Pressure Relief Valve to Tap Retract	H6-06	1

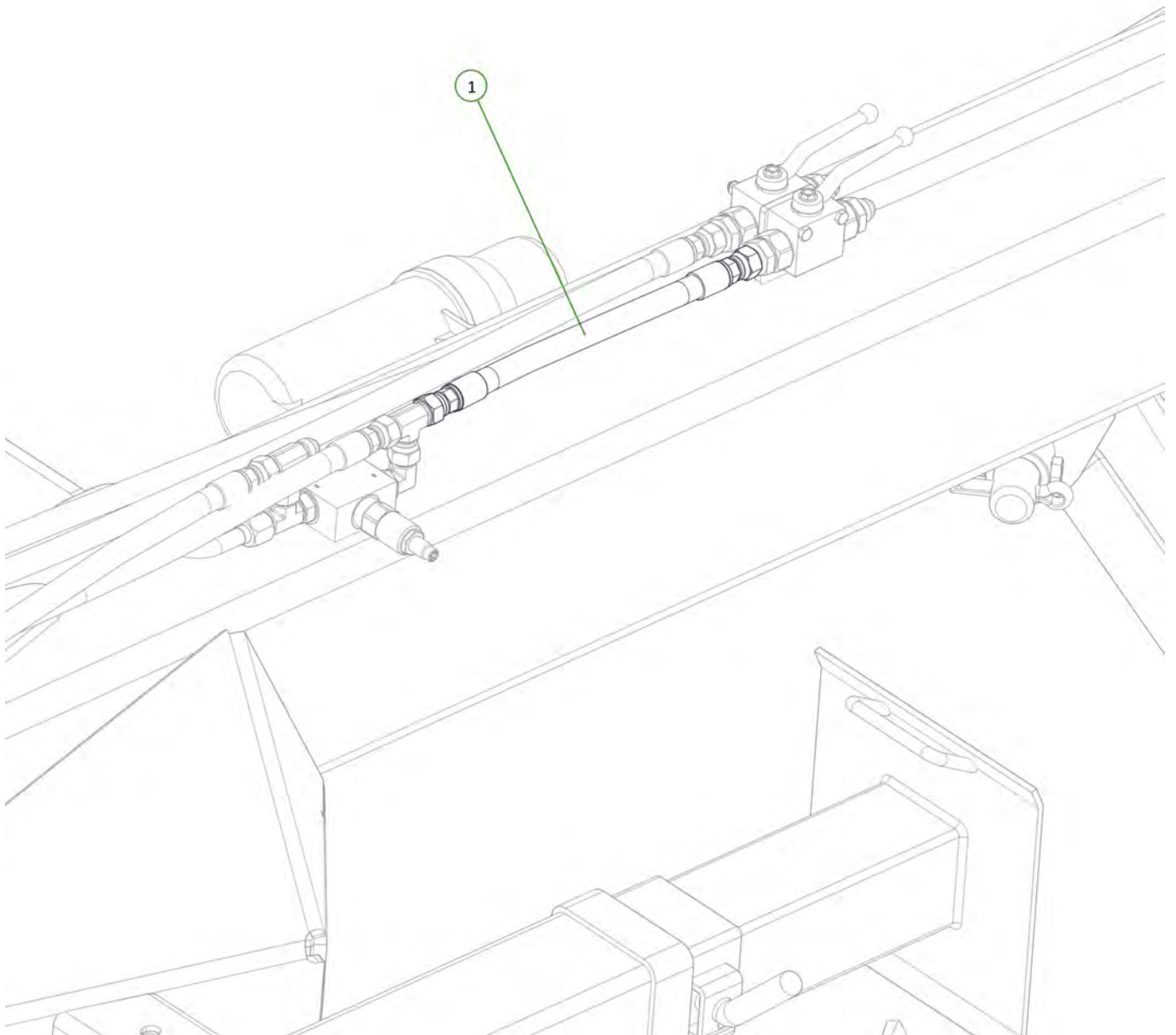
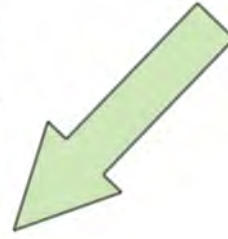

Item No.	Description	Number	Qty
1	Pressure Relief Valve to Bulk Head Fitting Extend	H6-05	1
2	3/4" JIC Male Bulkhead 3/4" JIC Male 3/4" JIC Male Tee	0324-S62-121212	1

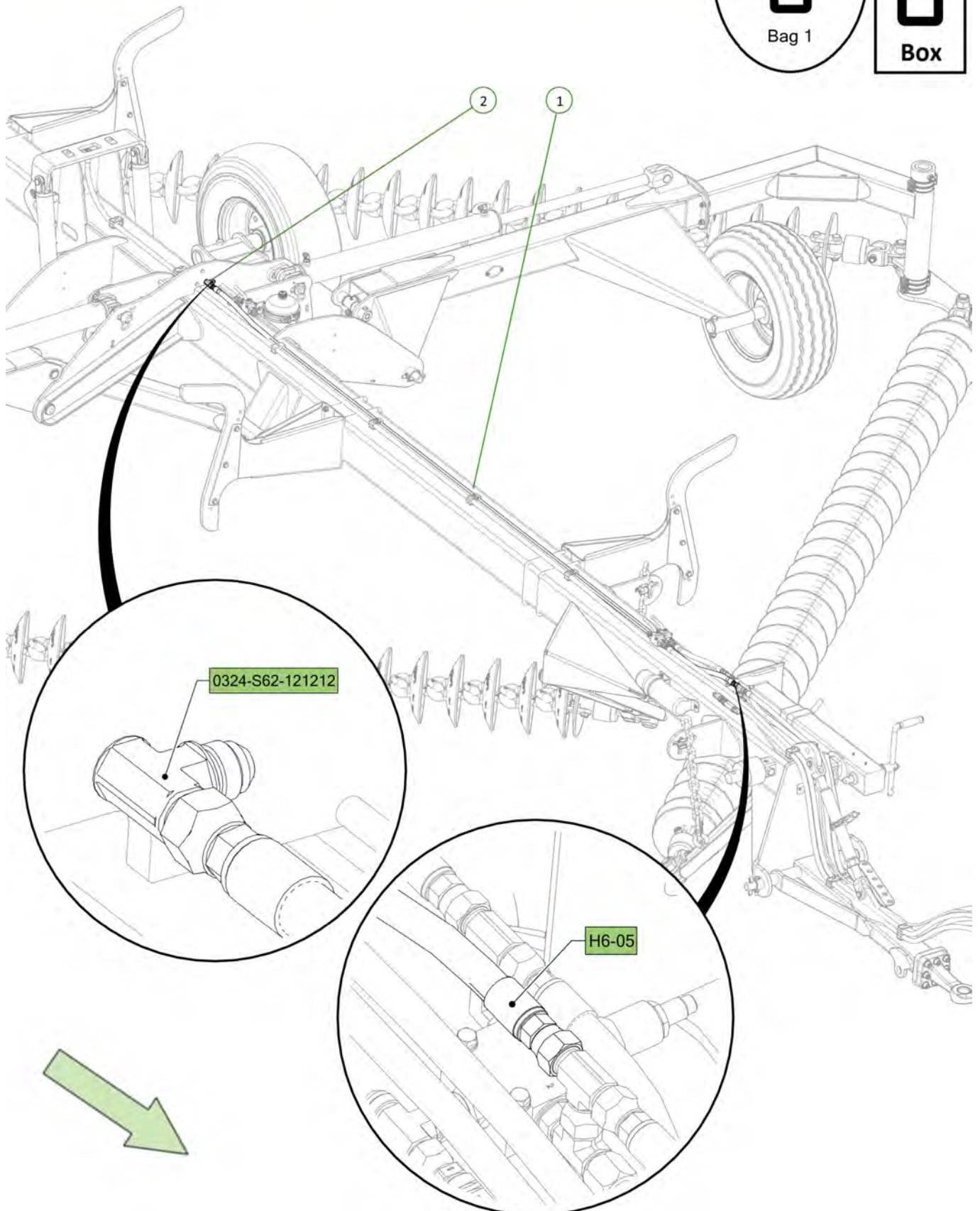
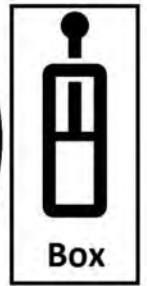

Item No.	Description	Number	Qty
1	Wheel Lift Tap to Wheel Lift Extend	H6-13	1

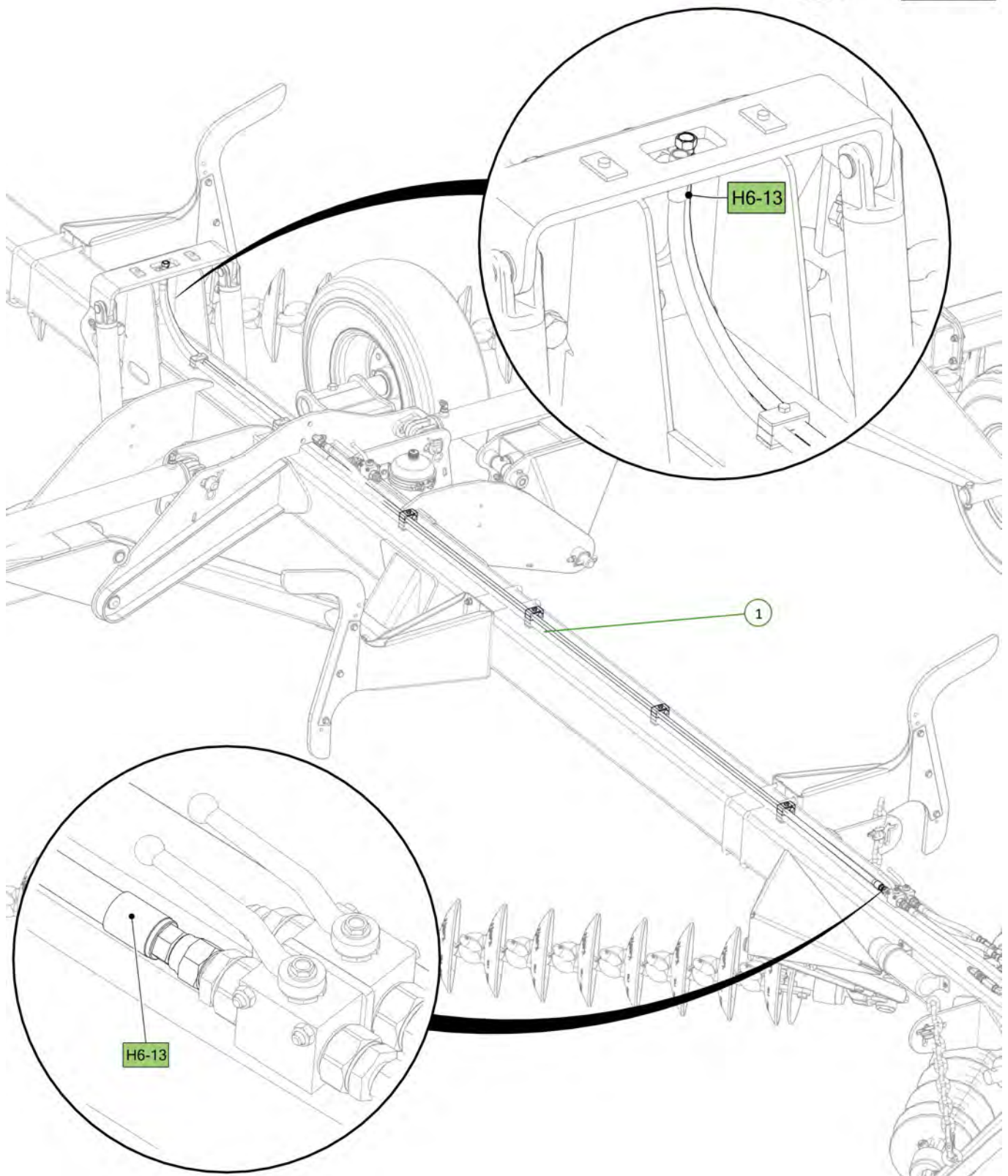
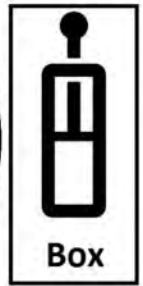

Item No.	Description	Number	Qty
1	Tap to Bulk Head Fitting Retract	H6-04	1
2	3/4" JIC Male Bulkhead 3/4" JIC Male 3/4" JIC Male Tee	0324-S62-121212	1

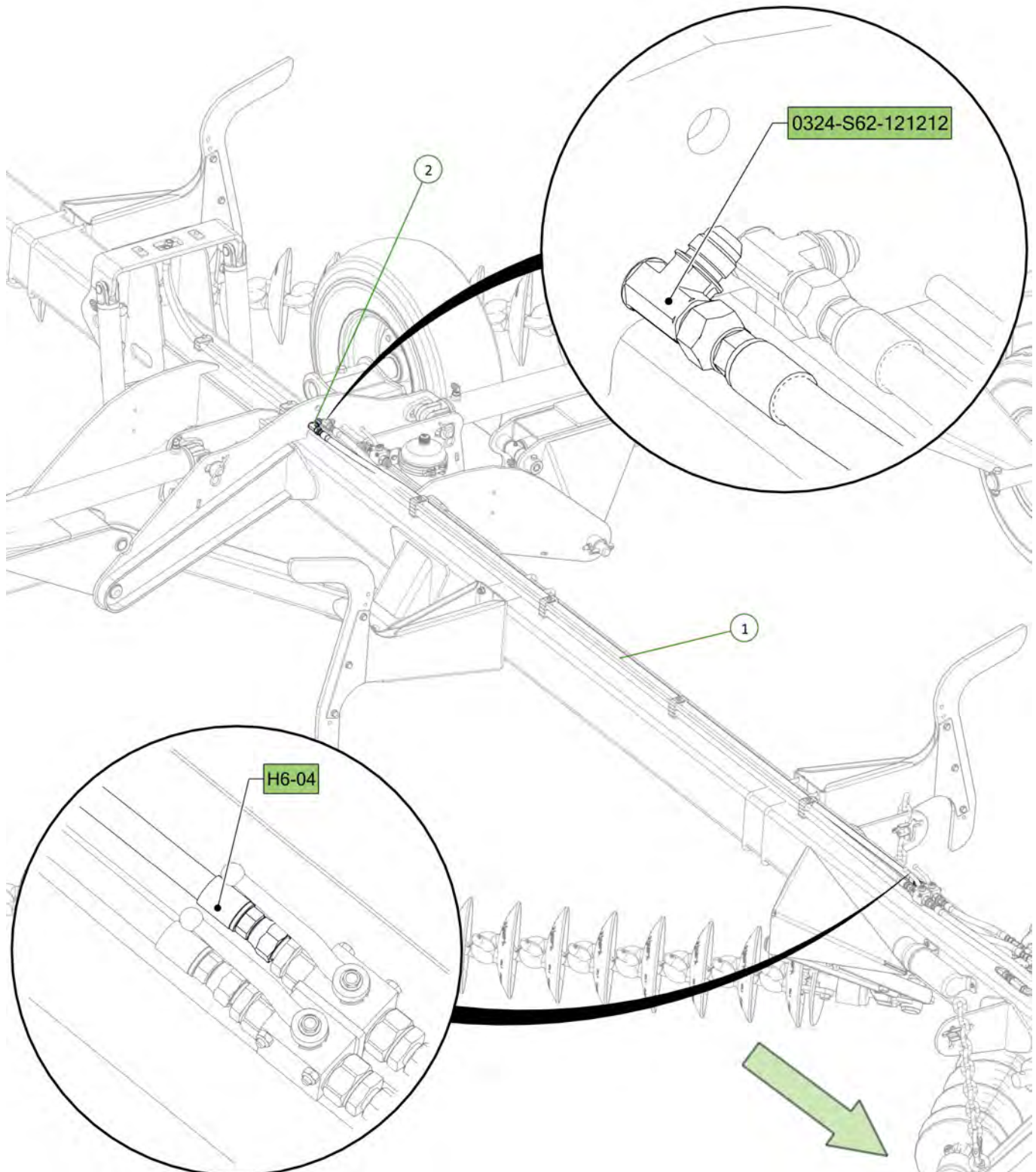
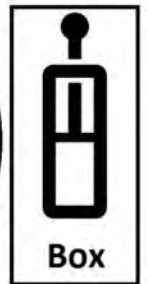

Item No.	Description	Number	Qty
1	Pressure to Tap	H6-20	1

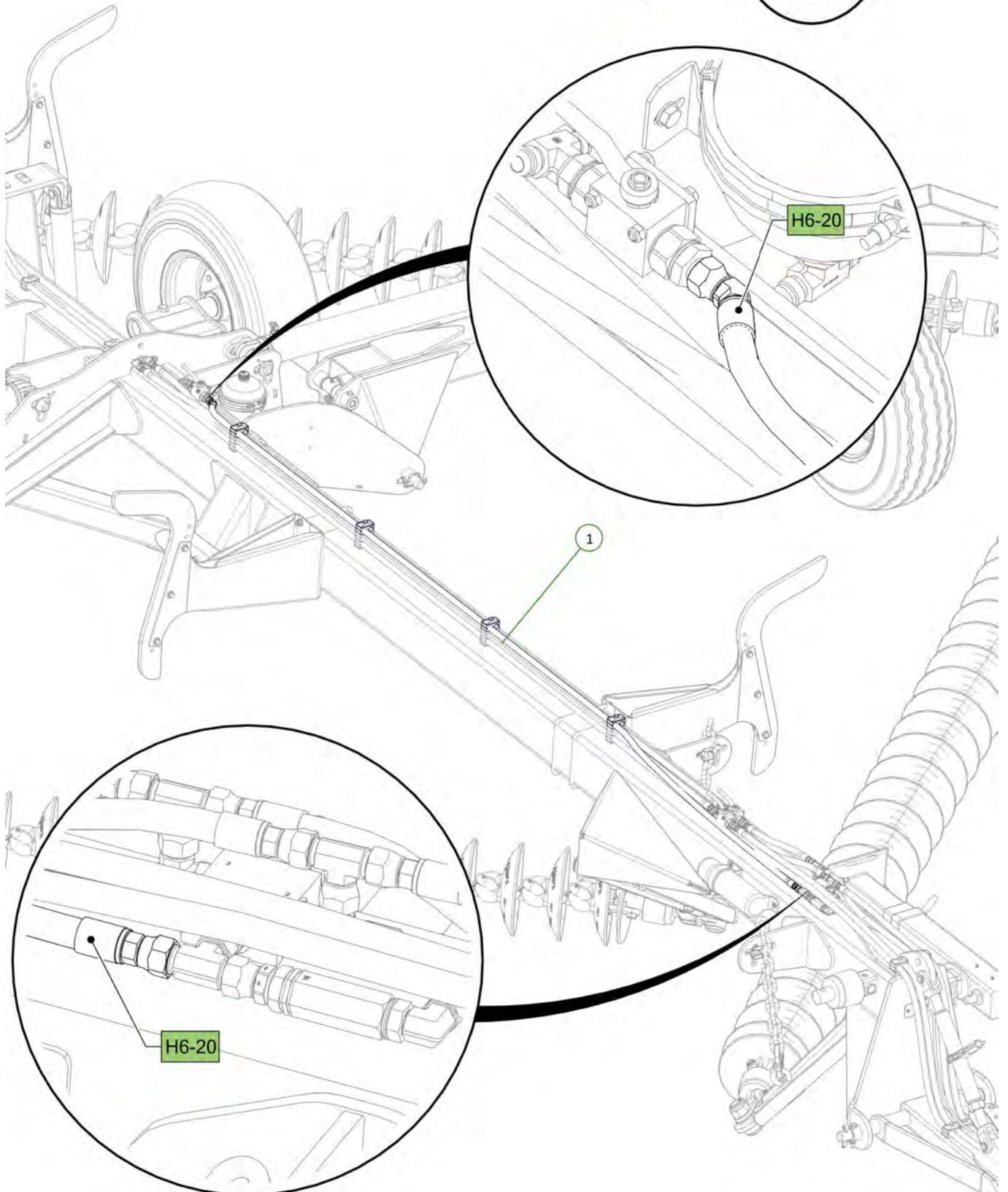

Item No.	Description	Number	Qty
1	Tension Tap to Bulkhead Fitting	H6-18	1
2	3/4" JIC Male Bulkhead 3/4" JIC Male	0323-S10-1212	1

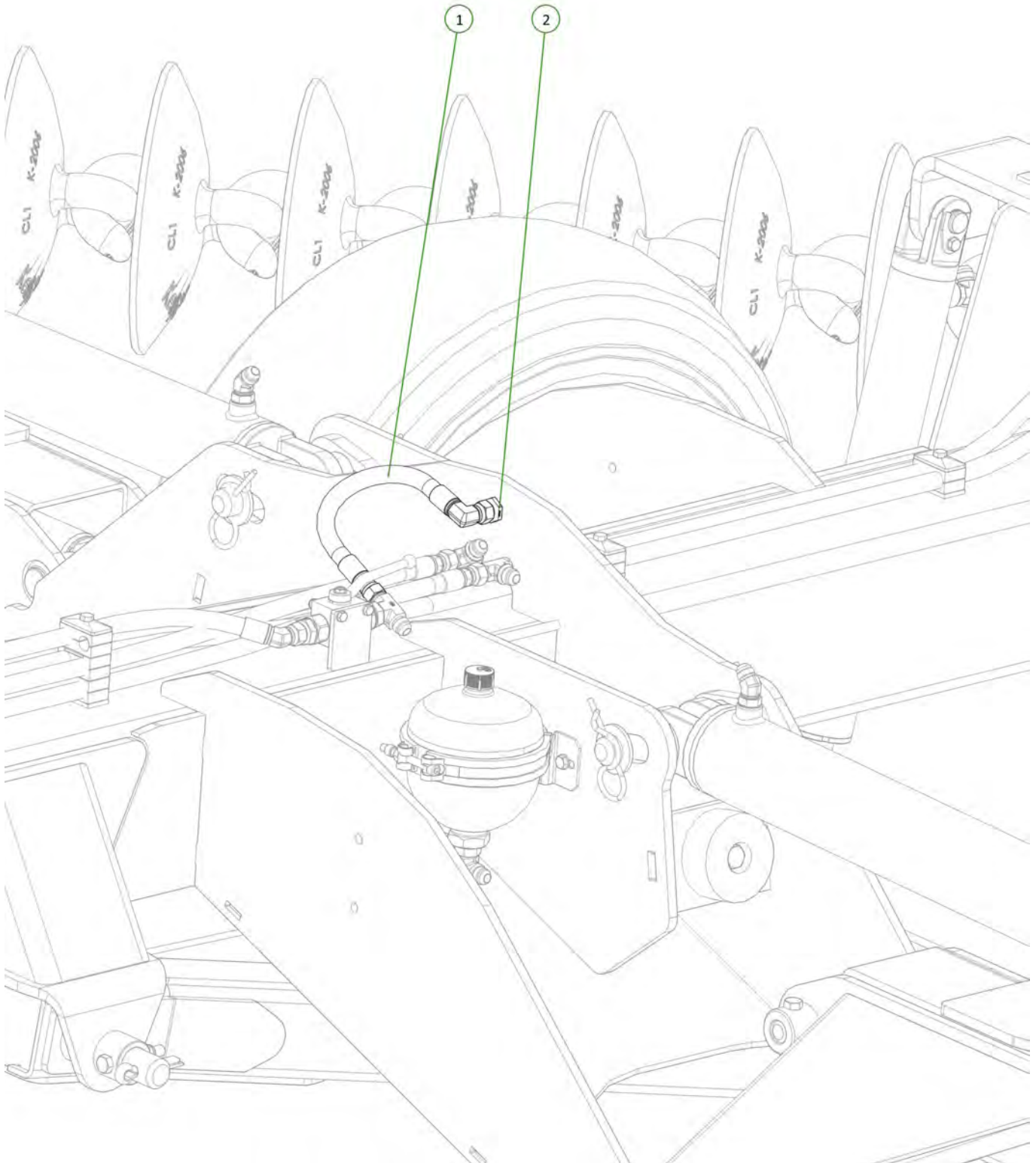
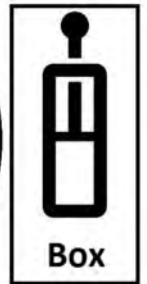

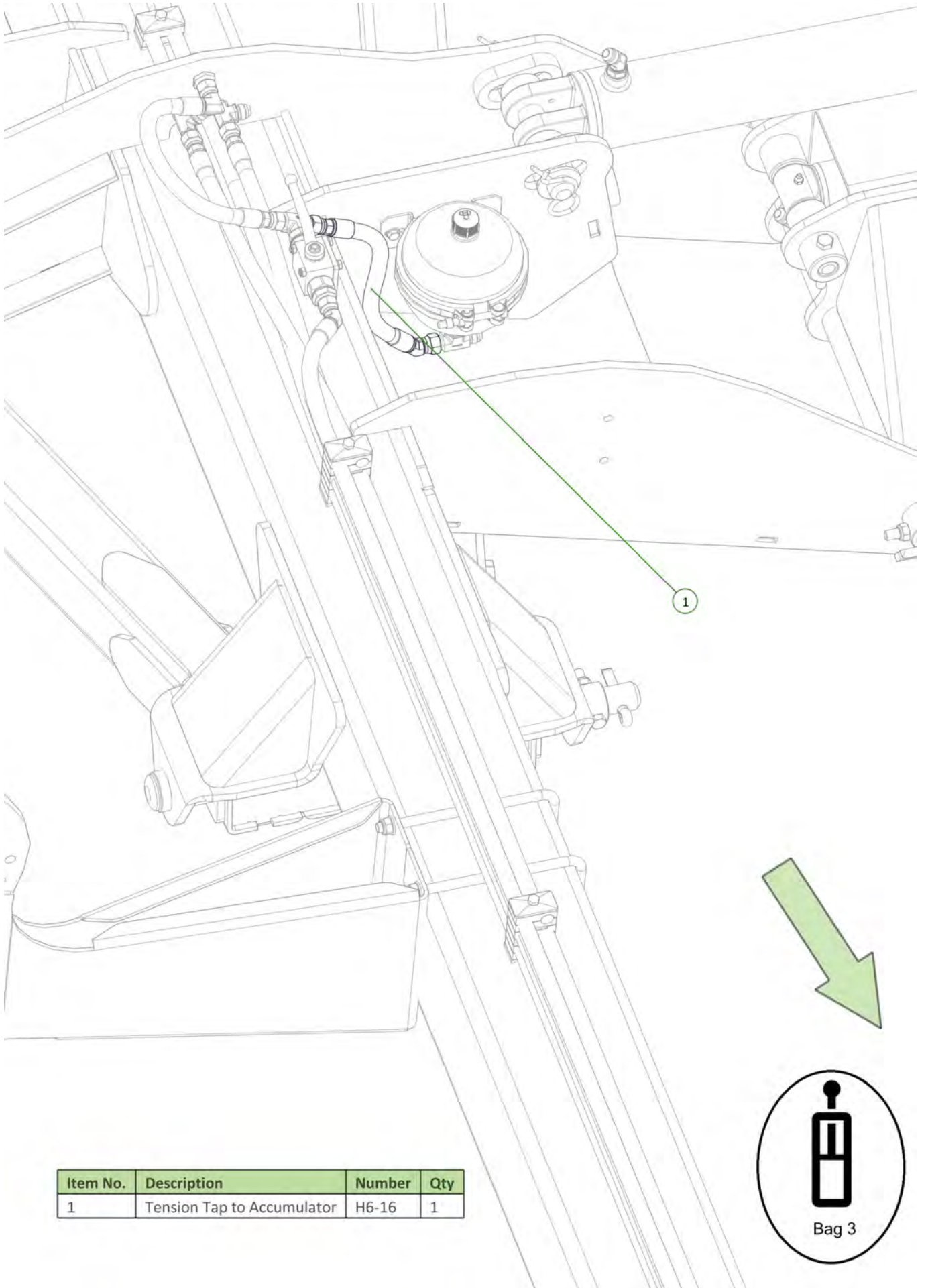

Item No.	Description	Number	Qty
1	Tension Tap to Accumulator	H6-16	1



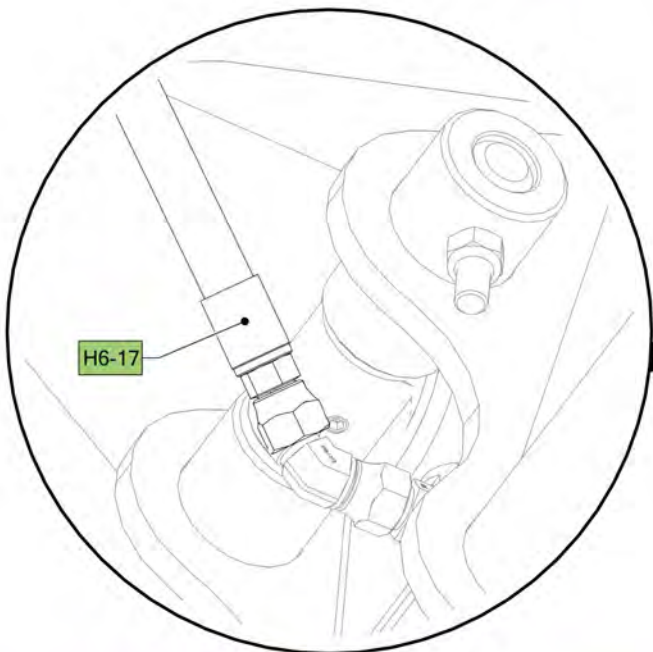
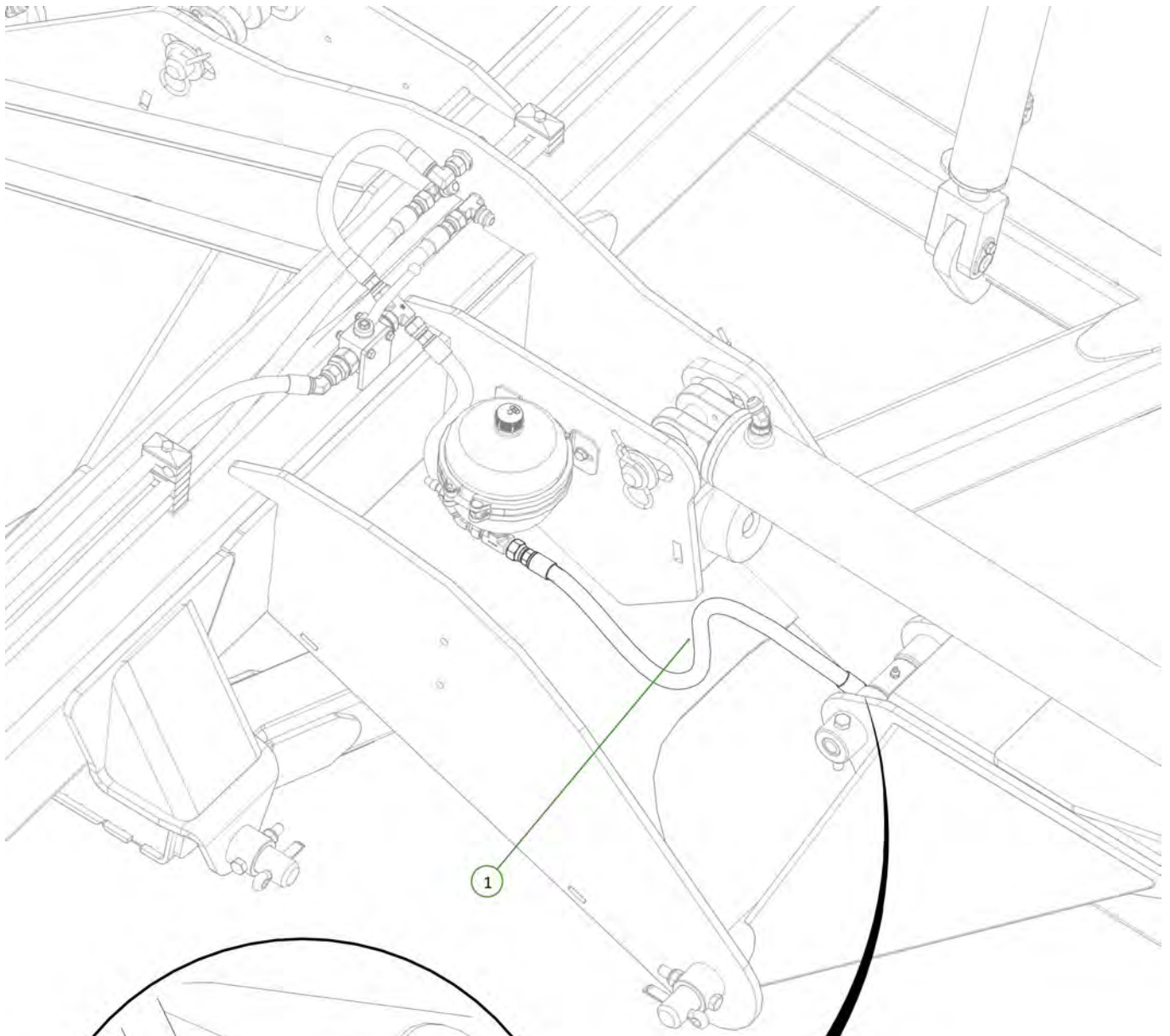

Item No.	Description	Number	Qty
1	Accumulator to Left Hand Tension Cylinder	H6-17	1

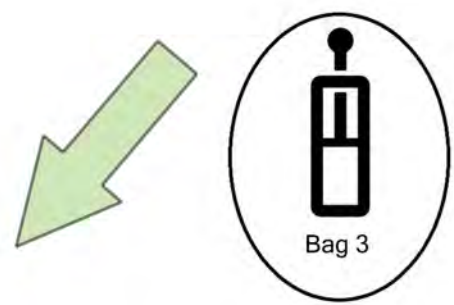

Item No.	Description	Number	Qty
1	Bulkhead to Right Hand Tension Cylinder	H6-19	1
2	3/4" JIC Male 3/4" JIC Female Swivel Inline Test Point	0325-S159-121216	1

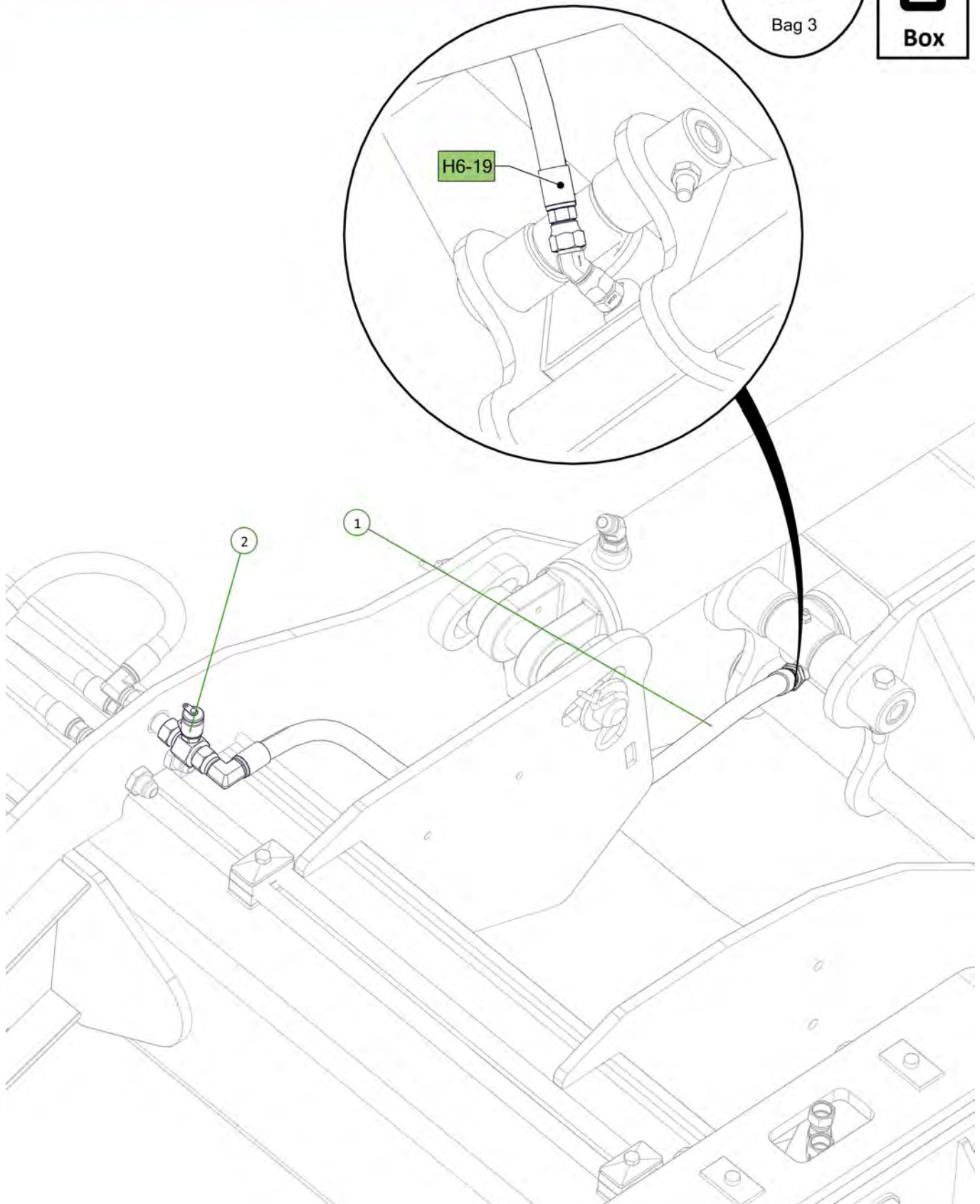
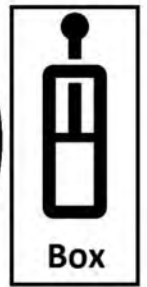

Item No.	Description	Number	Qty
1	3/4" JIC Male Tee 3/4" JIC Male Tee 3/4" JIC Male Tee	0324-S19-121212	2

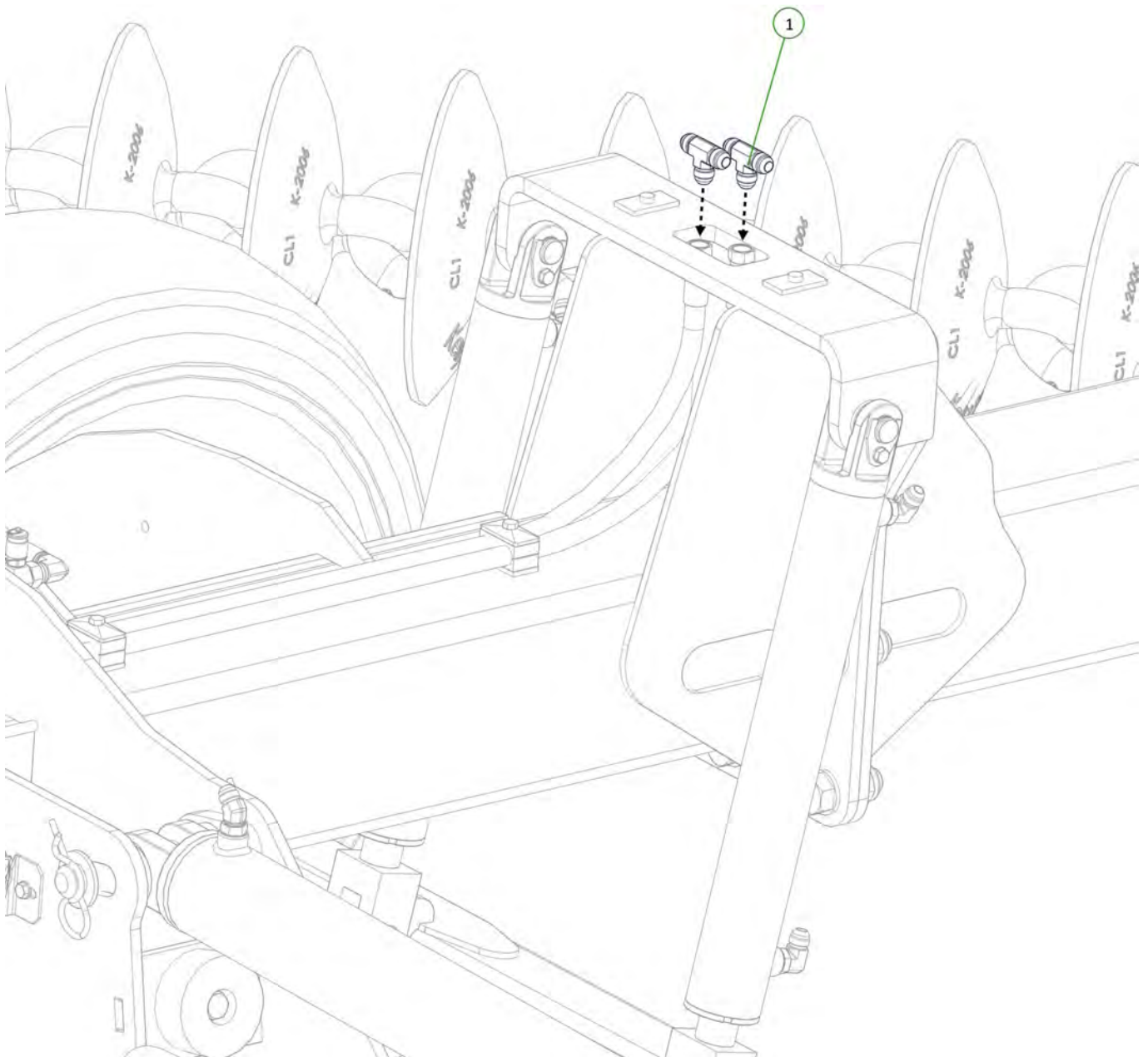
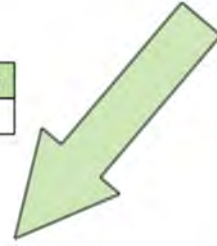

Item No.	Description	Number	Qty
1	Extend Tee to Cylinder Extend	H6-15	1
2	Retract Tee to Cylinder Extend	H6-14	1

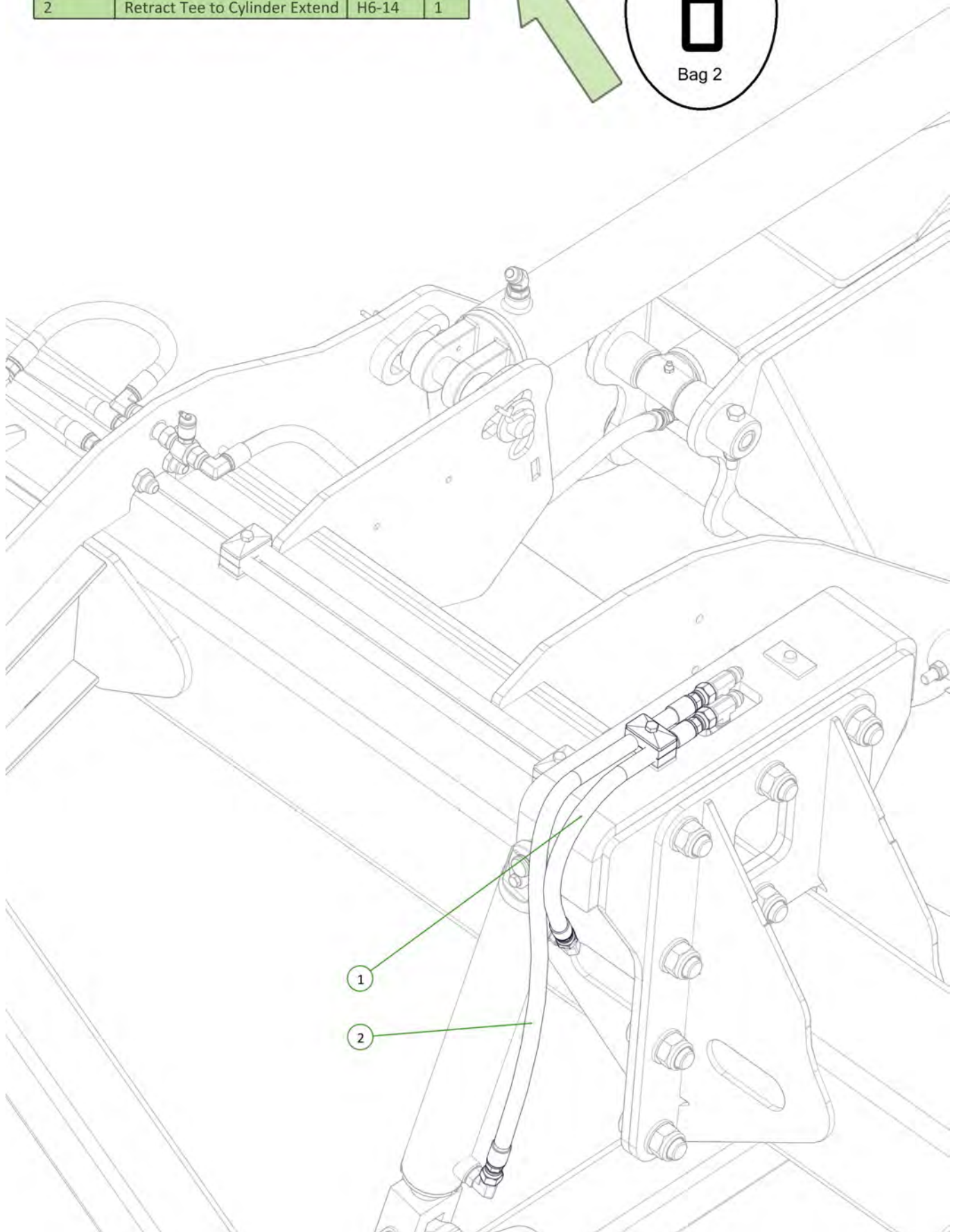

Item No.	Description	Number	Qty
1	Extend Tee to Cylinder Extend	H6-15	1
2	Retract Tee to Cylinder Retract	H6-14	1

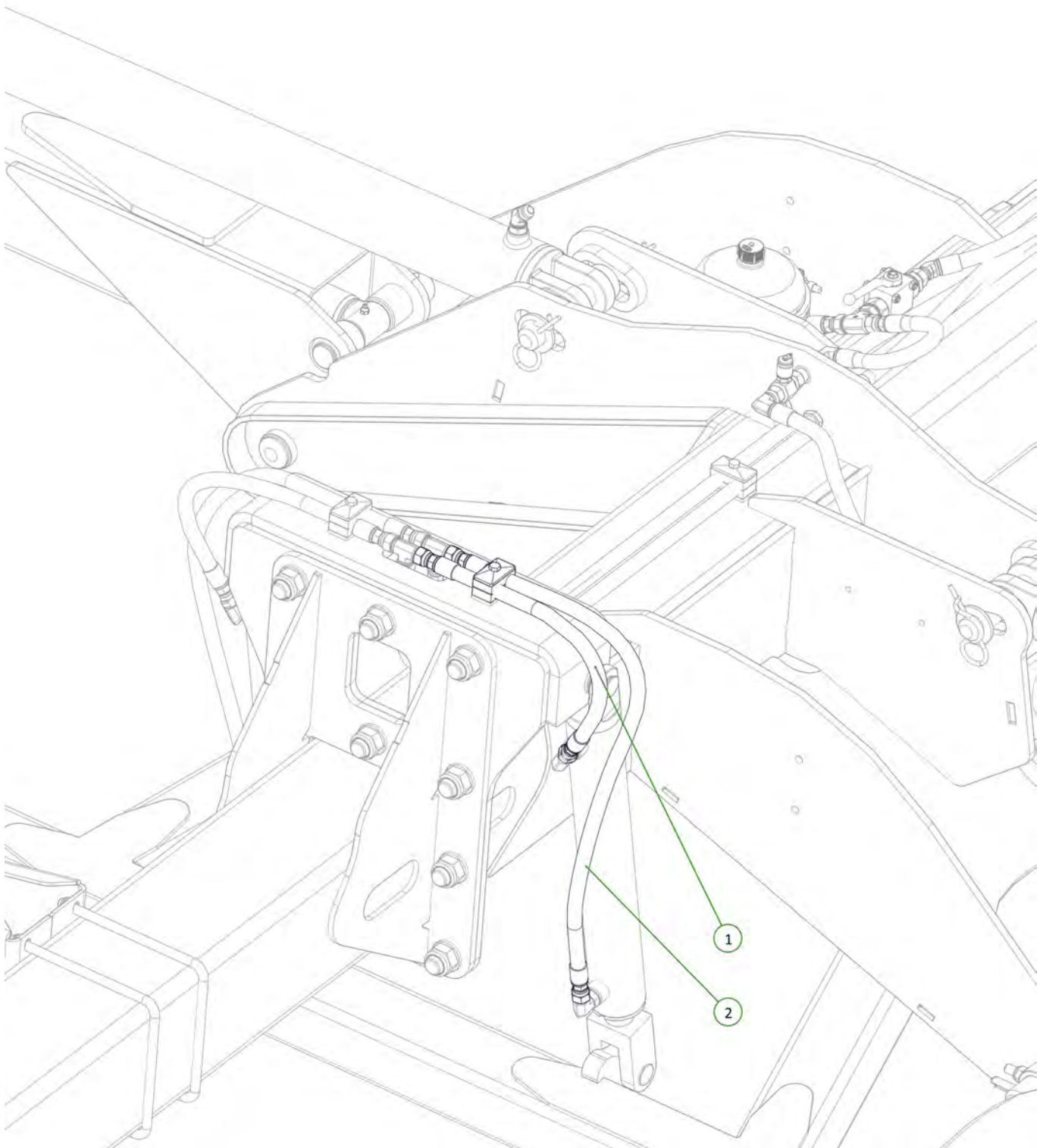

Item No.	Description	Number	Qty
1	Bulkhead to Right Hand Extend Port	H6-08	1
2	Bulkhead to Right Hand Retract Port	H6-07	1

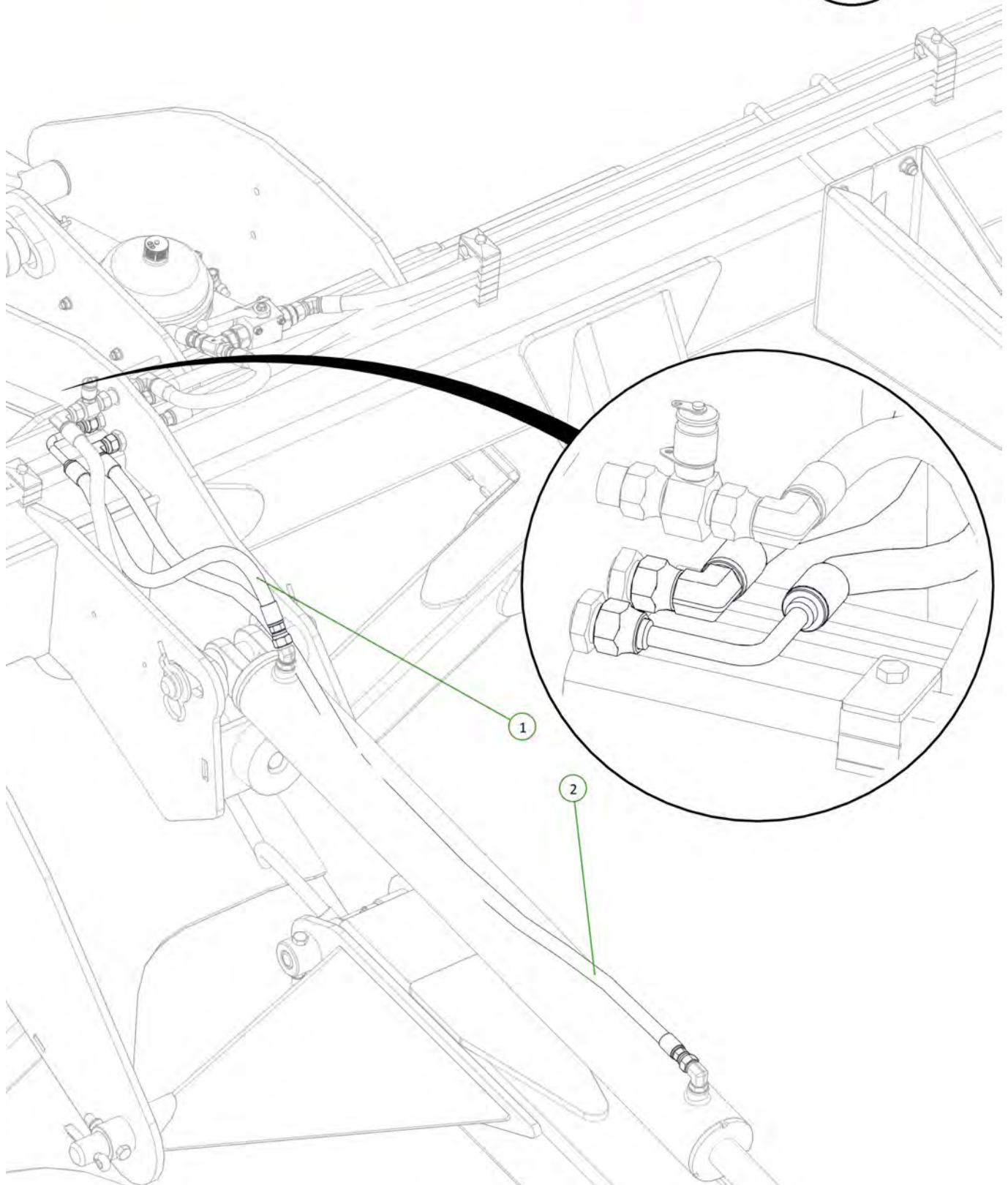

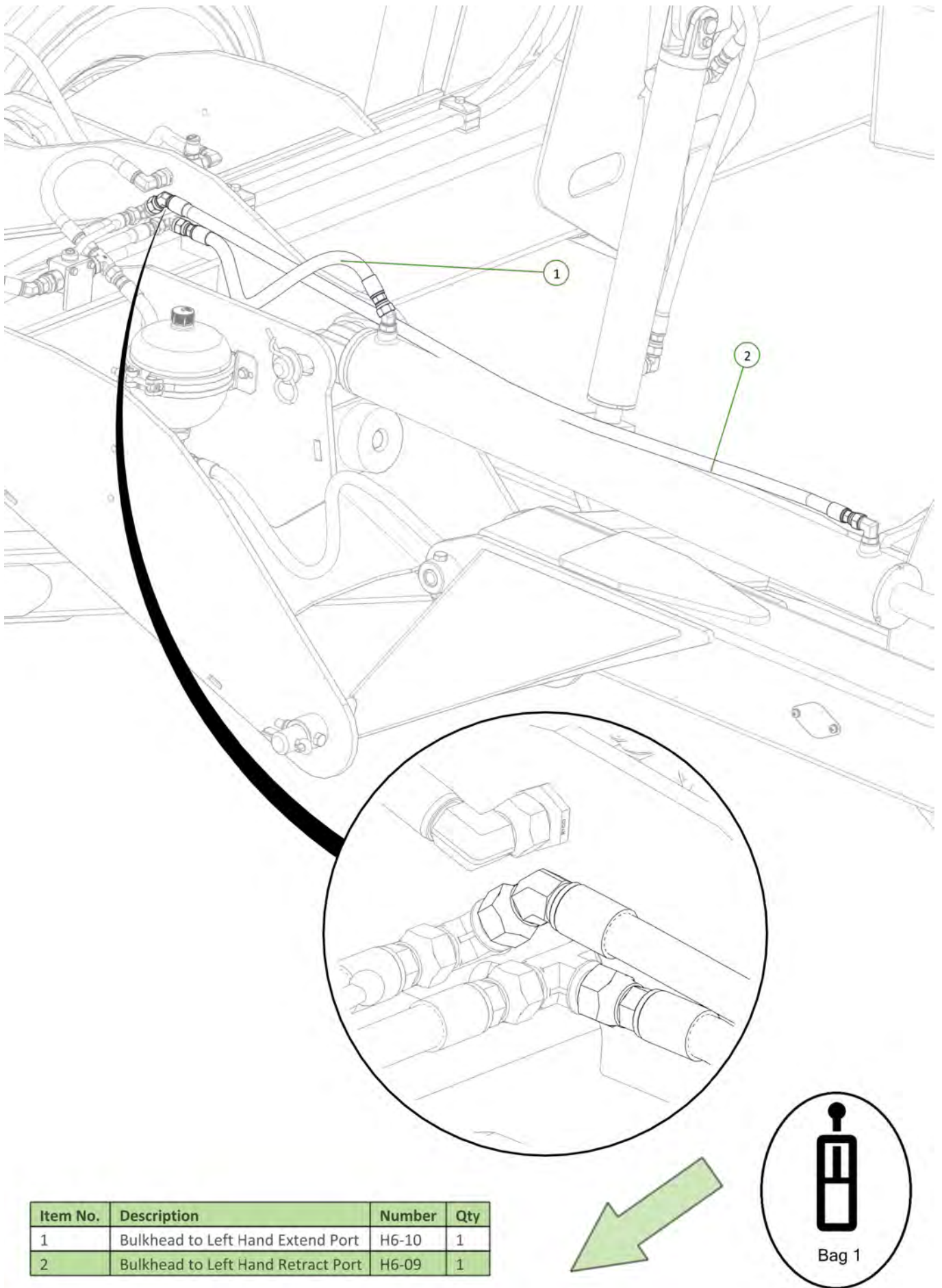

Item No.	Description	Number	Qty
1	Hydraulic Pressure Gauge 100mm x 250Bar	0325-GAUGE100-250-G	1
2	M16x2 Female 1/2" BSPP Female Gauge Adaptor	0325-C81-1608	1

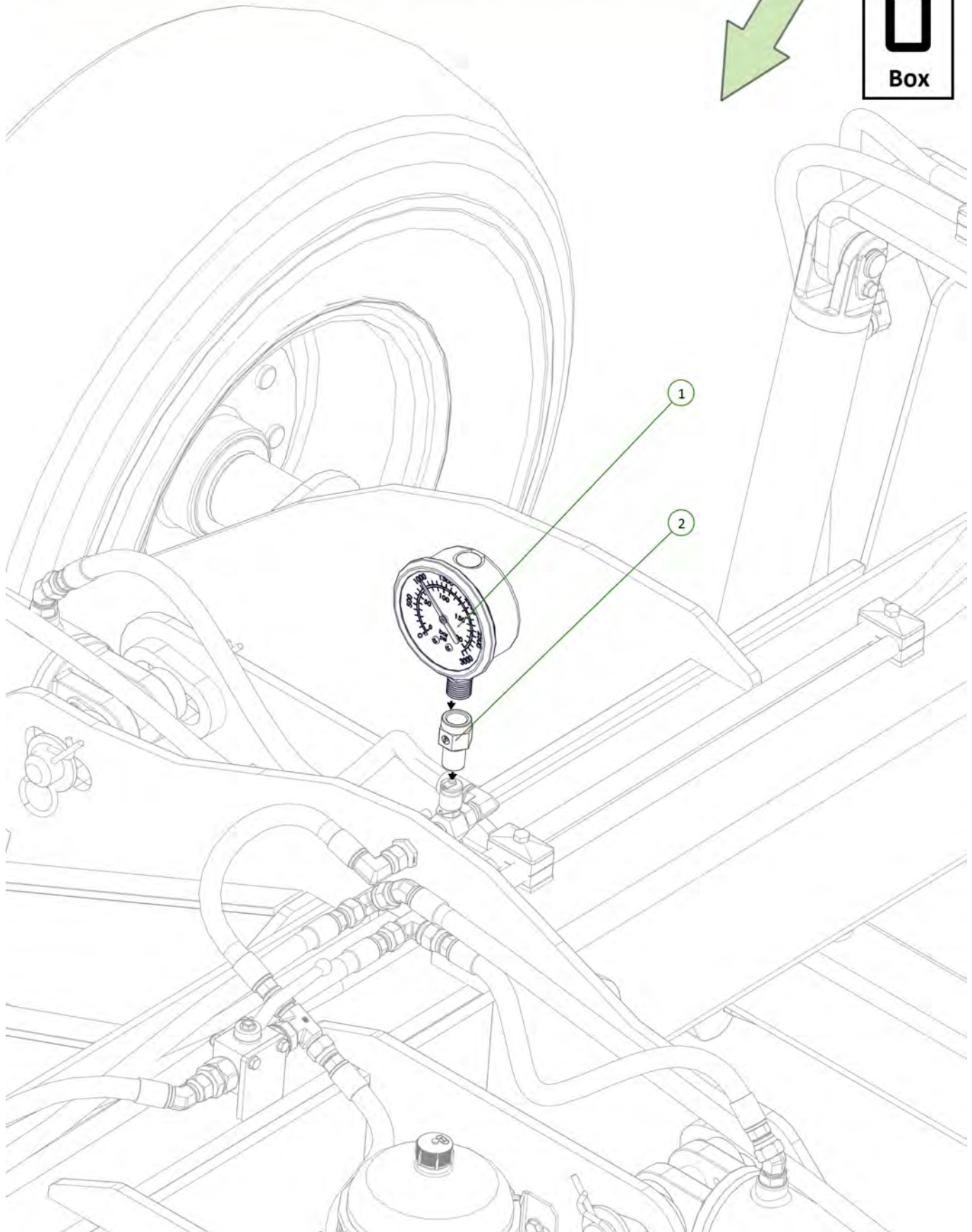

KELLY

Section 5 - Decal Application

Item No.	Description	Number	Qty
1	Electrocution Hazard Decal	0801-S6	1
2	Kelly Tillage Data Plate	0801-SKTDTP	1

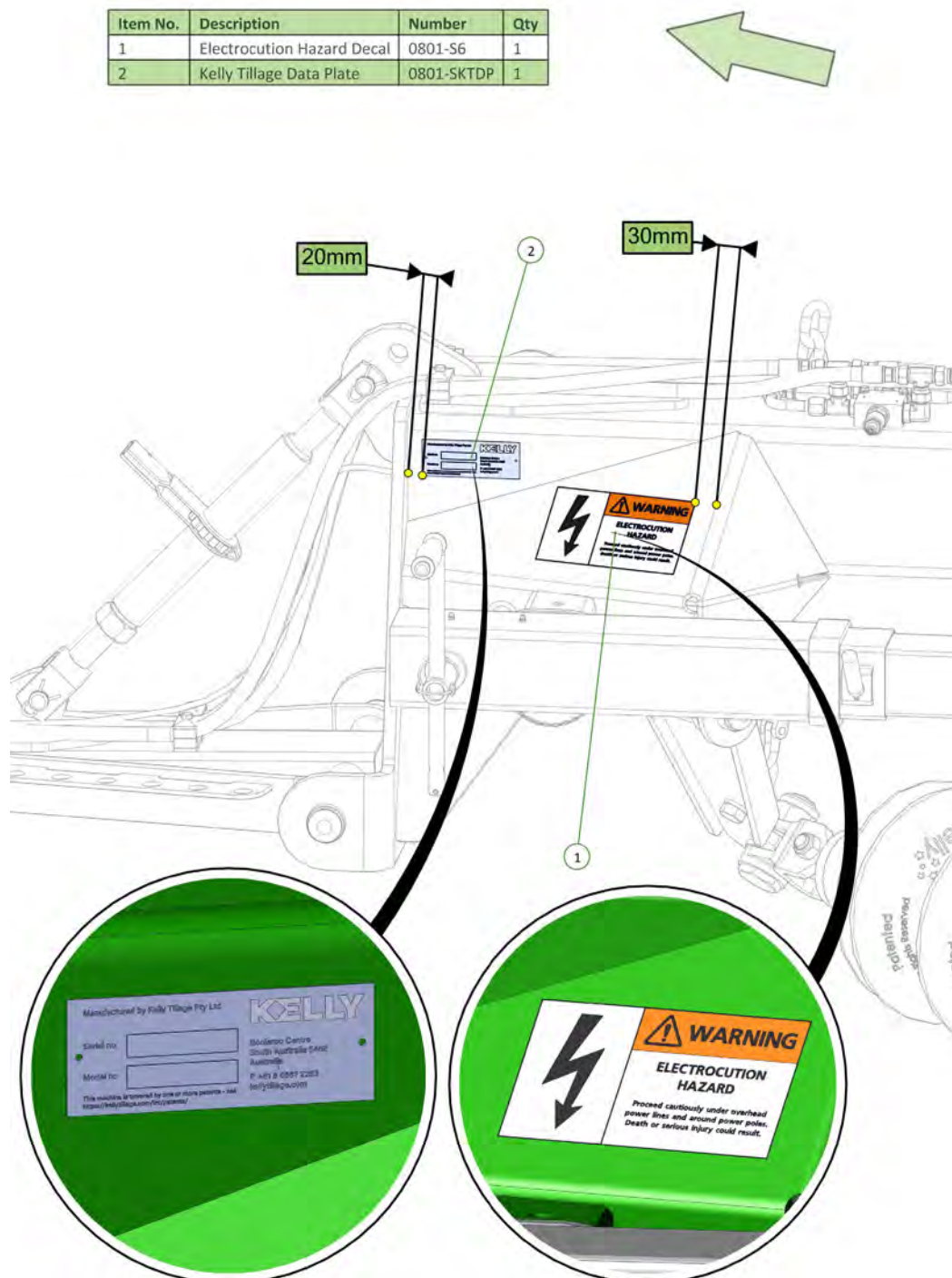

Item No.	Description	Number	Qty
1	Hydraulic Pressure Caution Decal	0801-S4	1
2	Towing Speed Decal	0801-S5	1

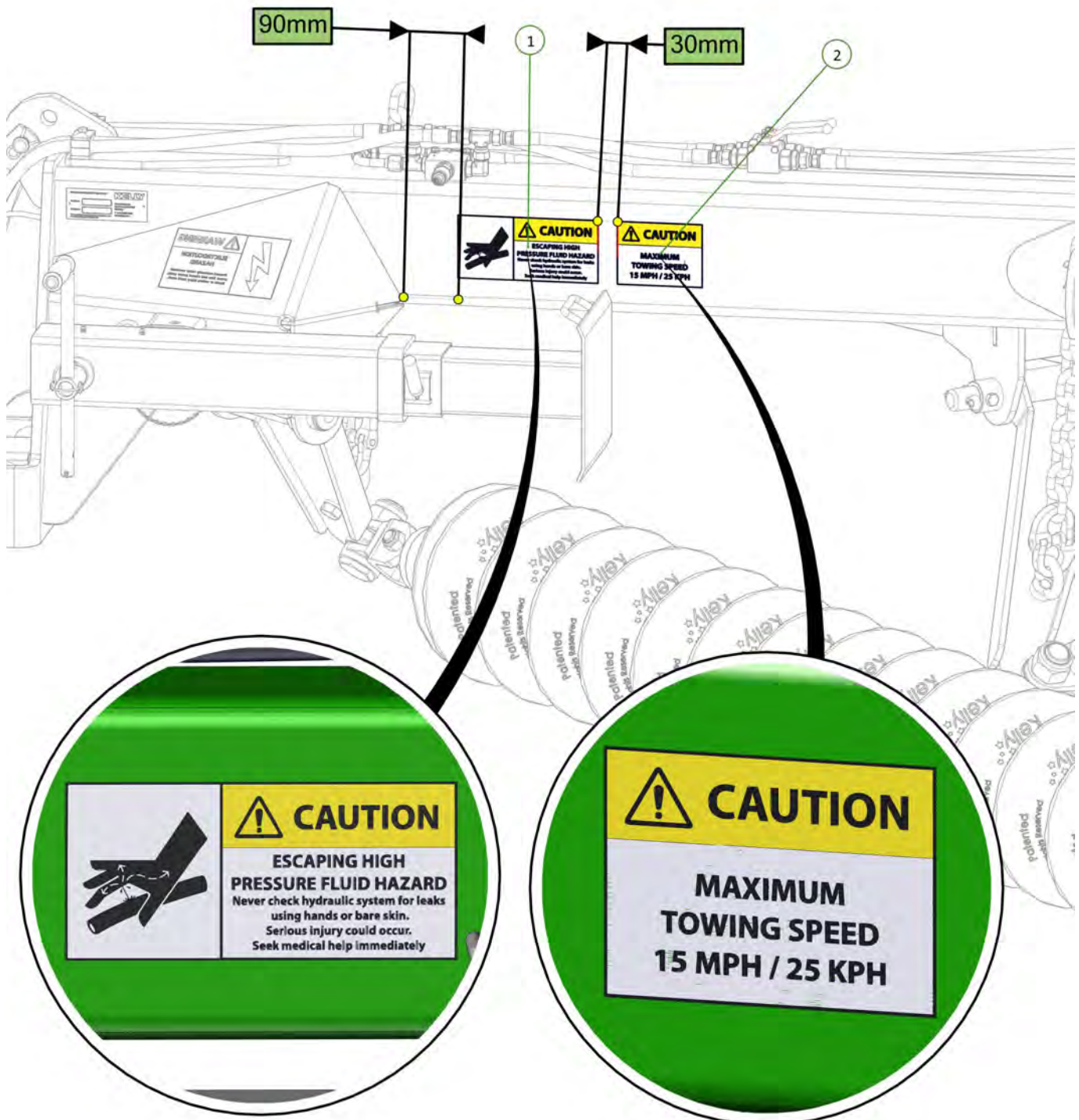

Item No.	Description	Number	Qty
1	Kelly Tillage 2006 Decal	0801-SKT2006	1

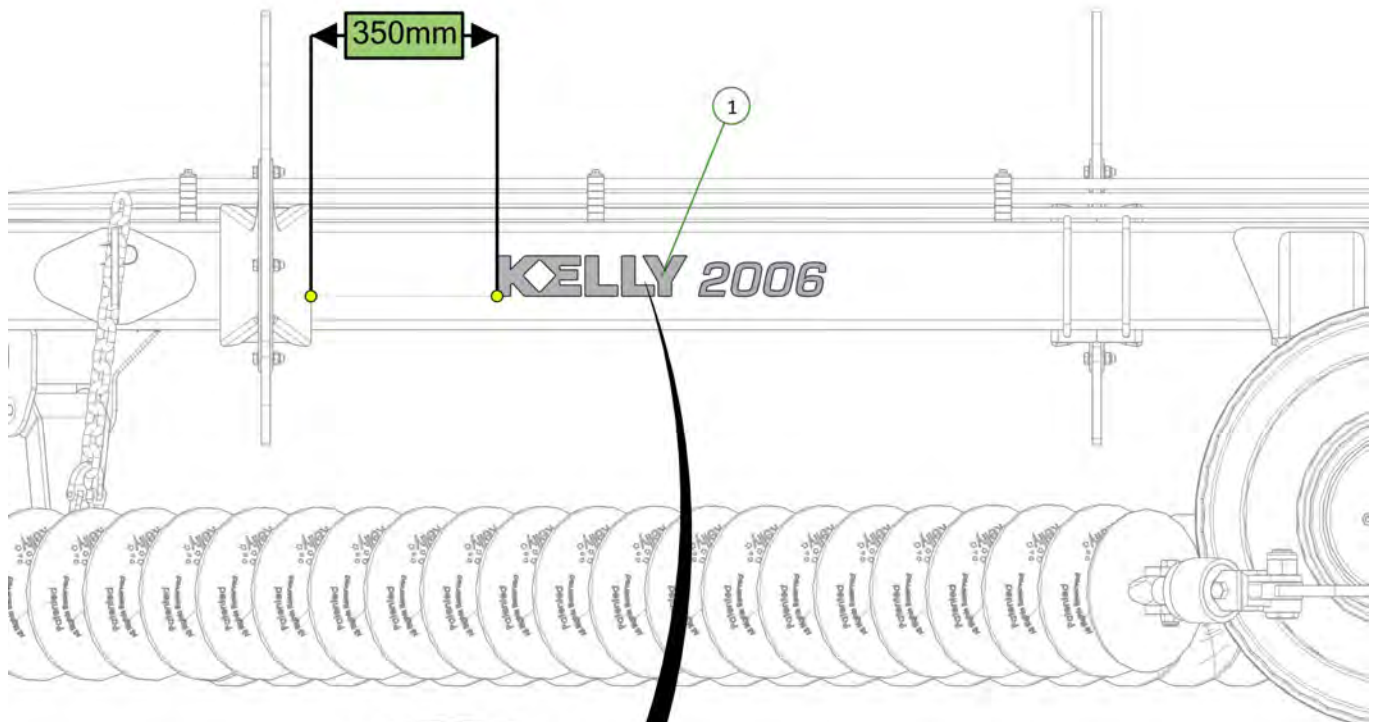
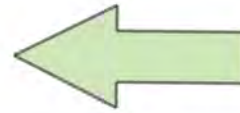

Item No.	Description	Number	Qty
1	Danger Crush Hazard Decal	0801-S3	1
2	Yellow Reflective Decal	0801-SYRF	1

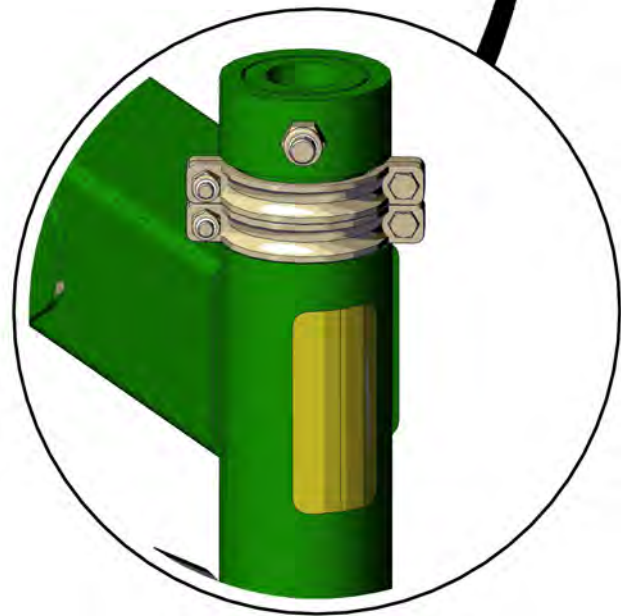
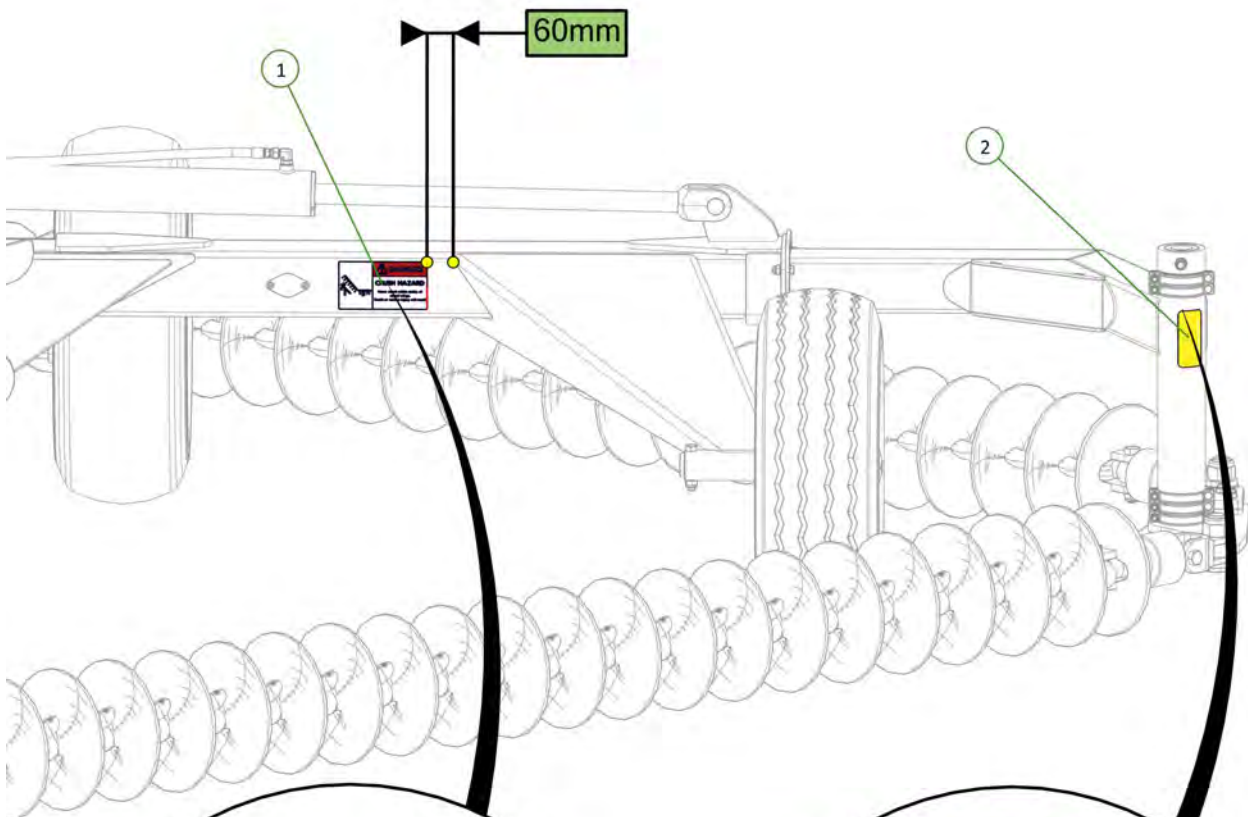
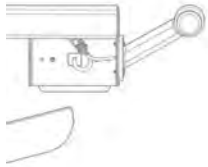
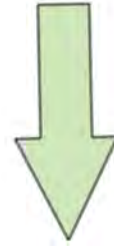

Item No.	Description	Number	Qty
1	Danger Crush Hazard Decal	0801-S3	1
2	Red Reflective Decal	0801-SRRF	1

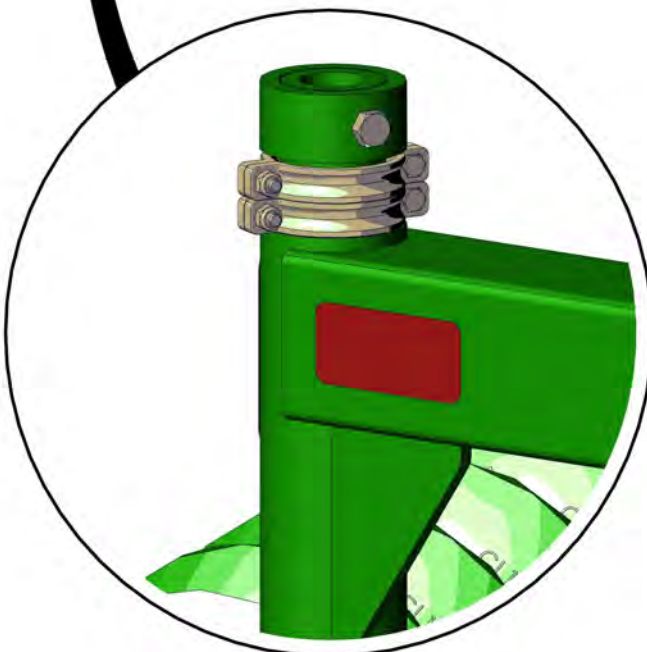
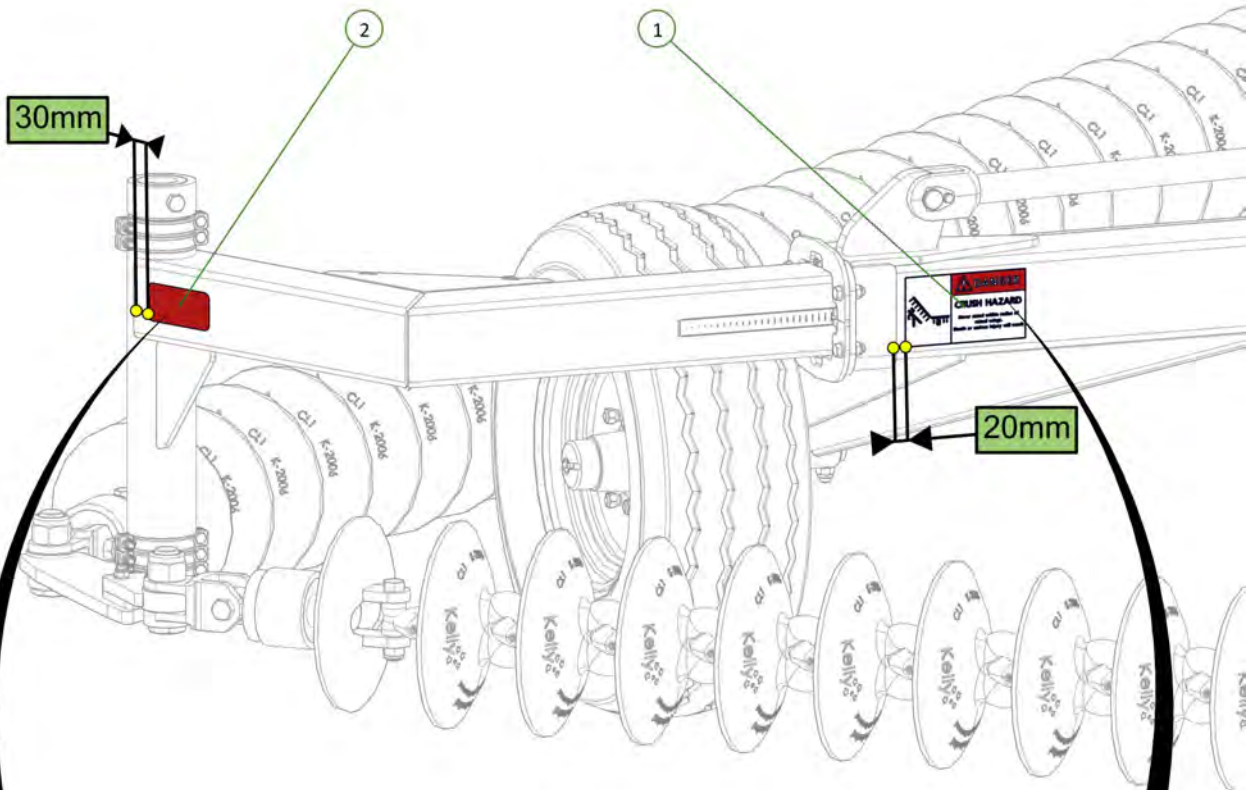
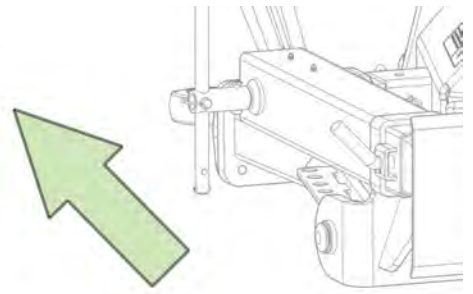

Item No.	Description	Number	Qty
1	Pinch Point Decal	0801-S17	1

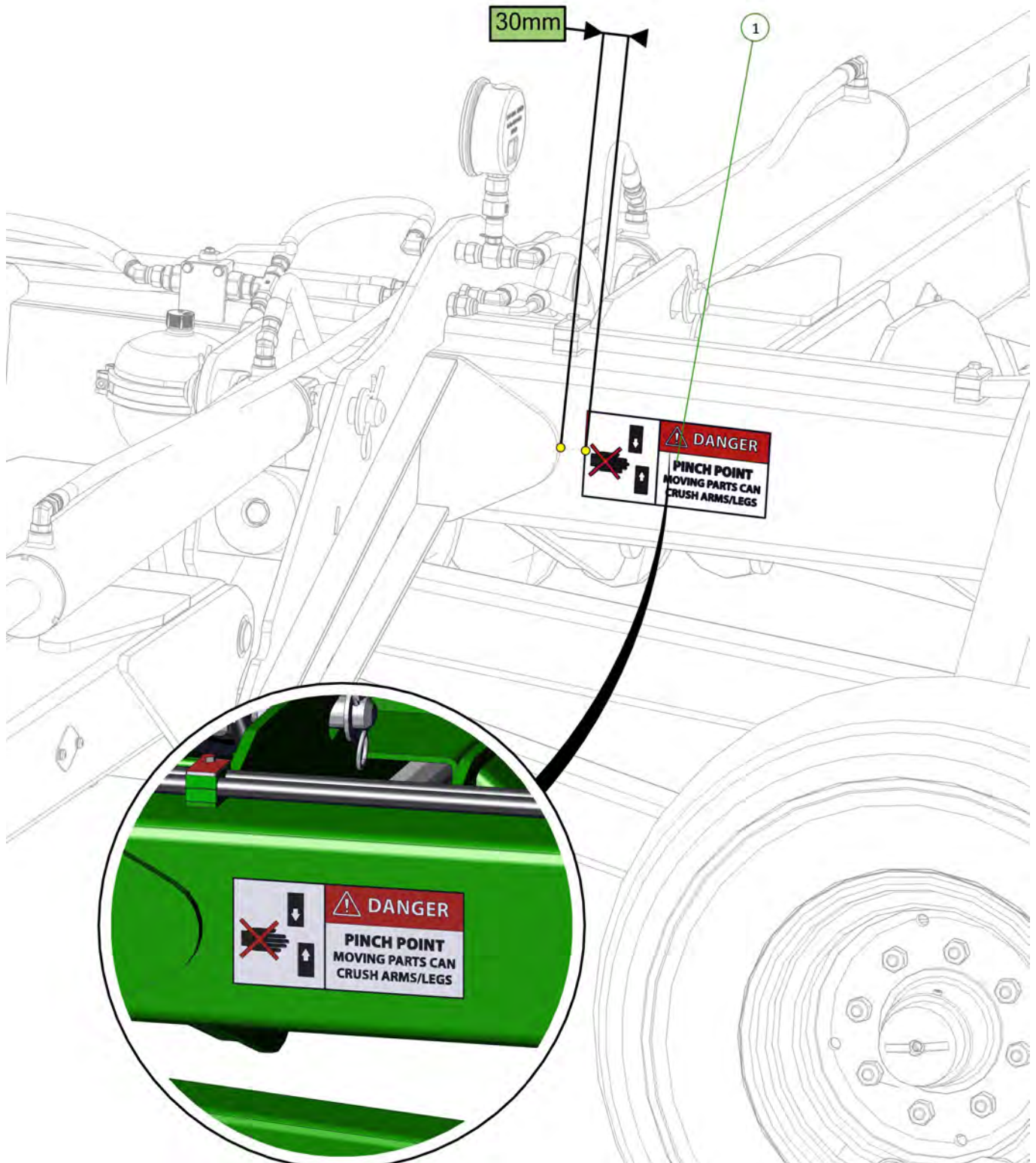
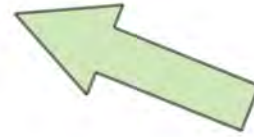

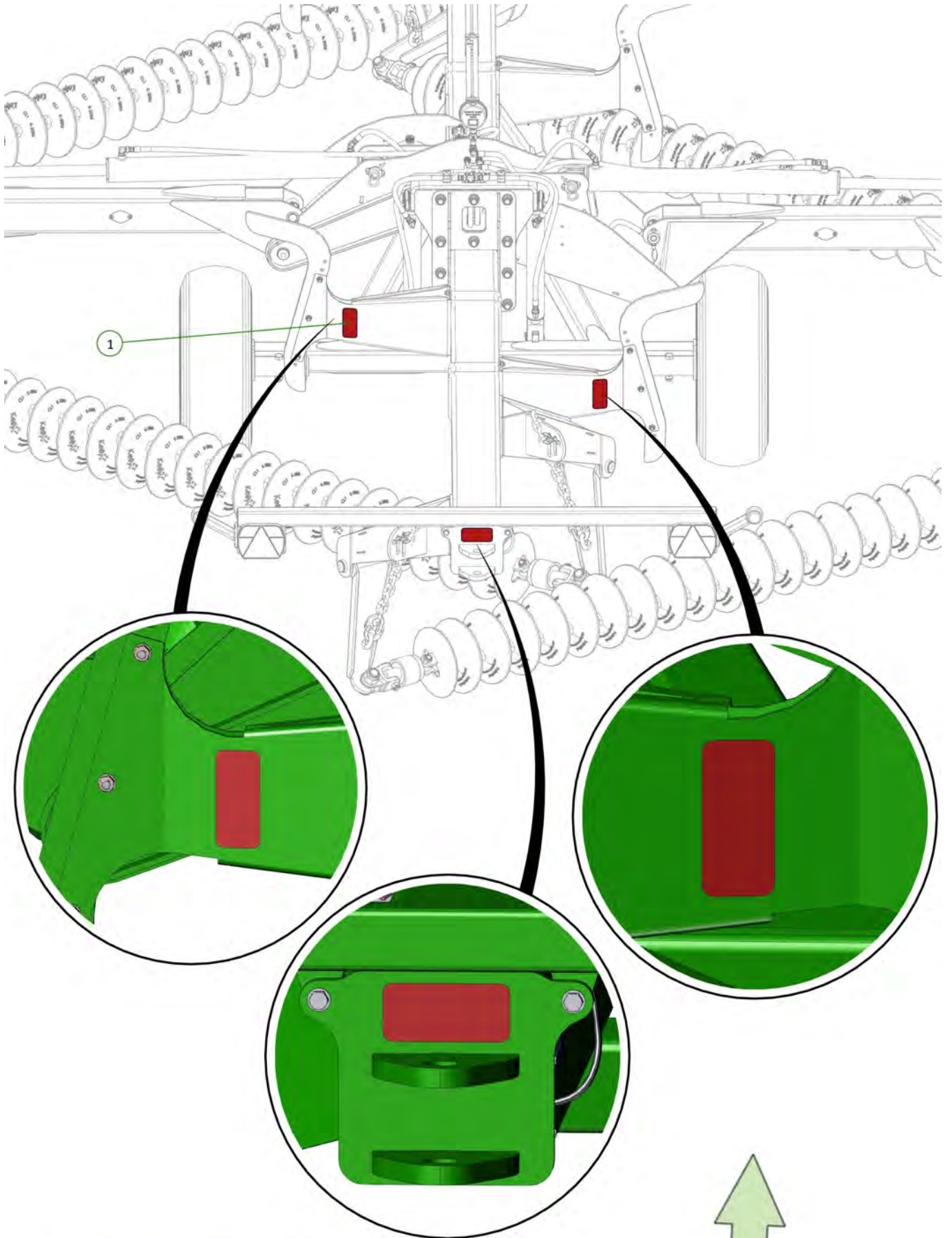

Item No.	Description	Number	Qty
1	Red Reflective Decal	0801-SRRF	3

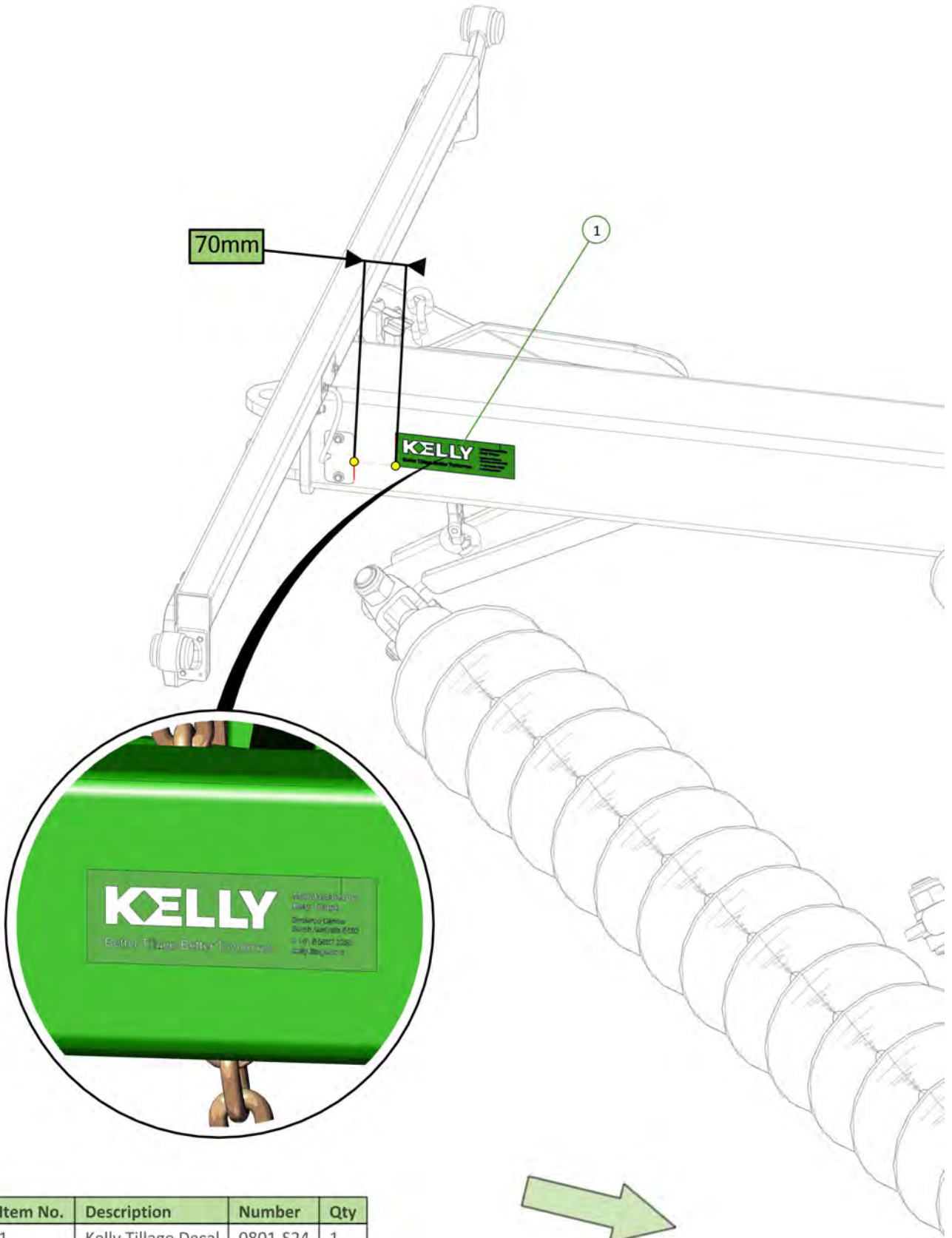

Item No.	Description	Number	Qty
1	Kelly Tillage Decal	0801-S24	1

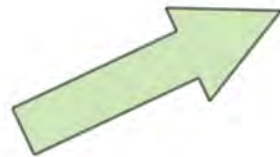
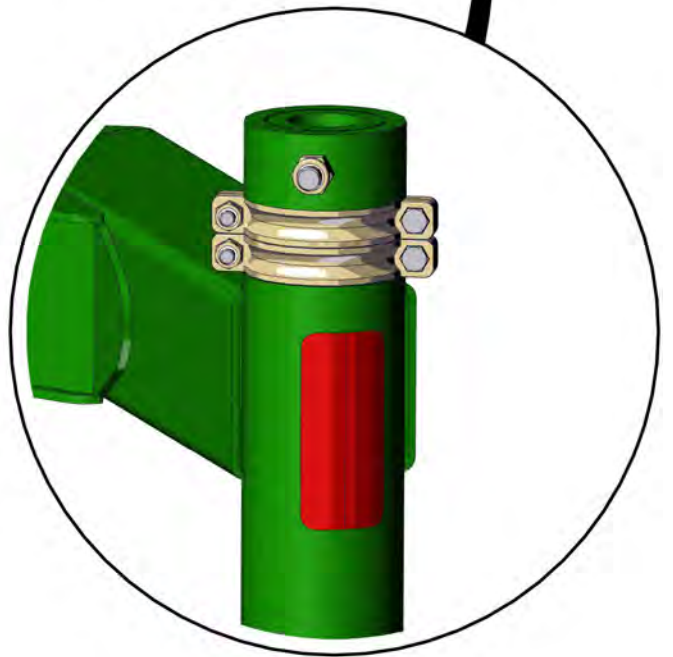
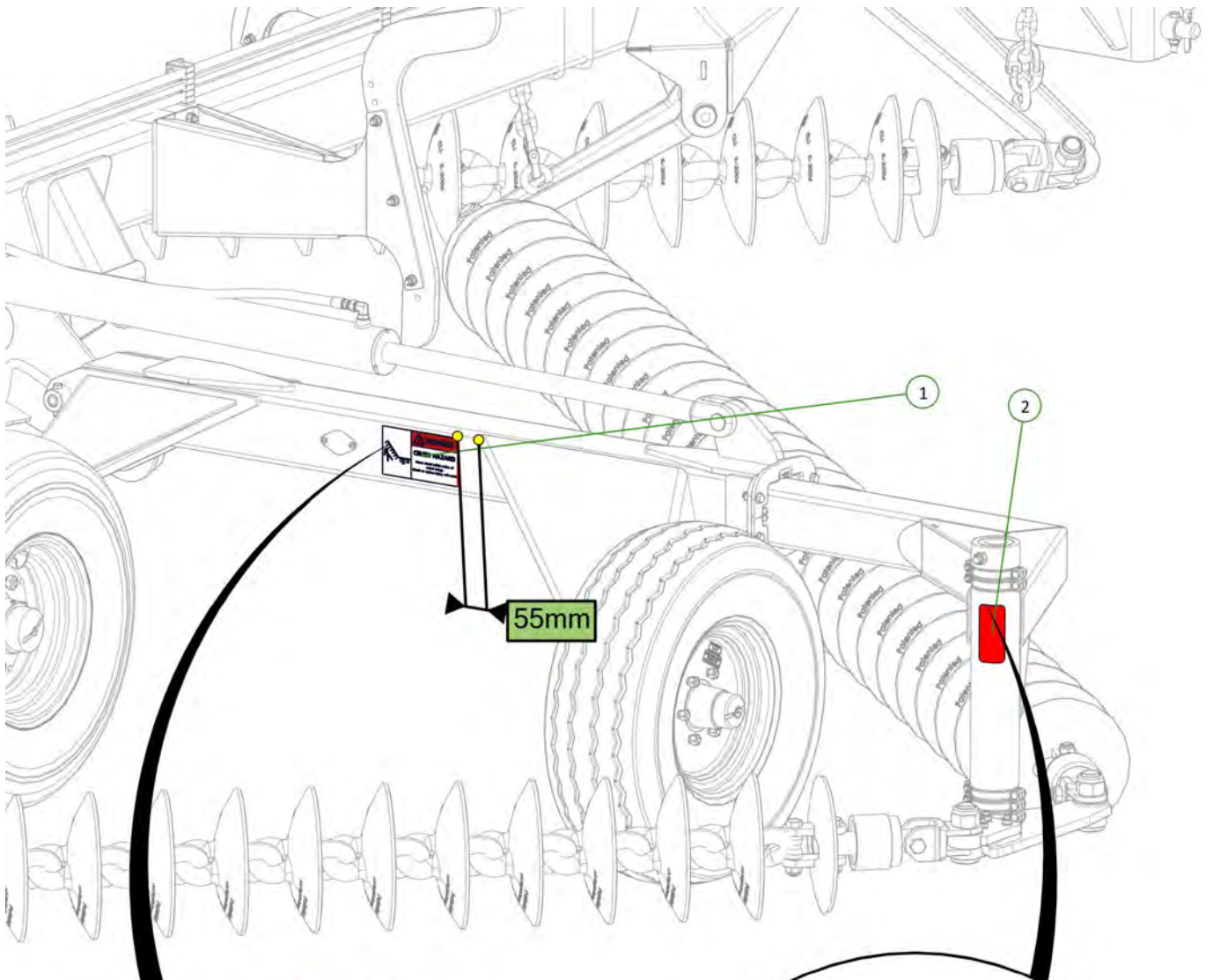

Item No.	Description	Number	Qty
1	Danger Crush Hazard Decal	0801-S3	1
2	Red Reflective Decal	0801-SRRF	1

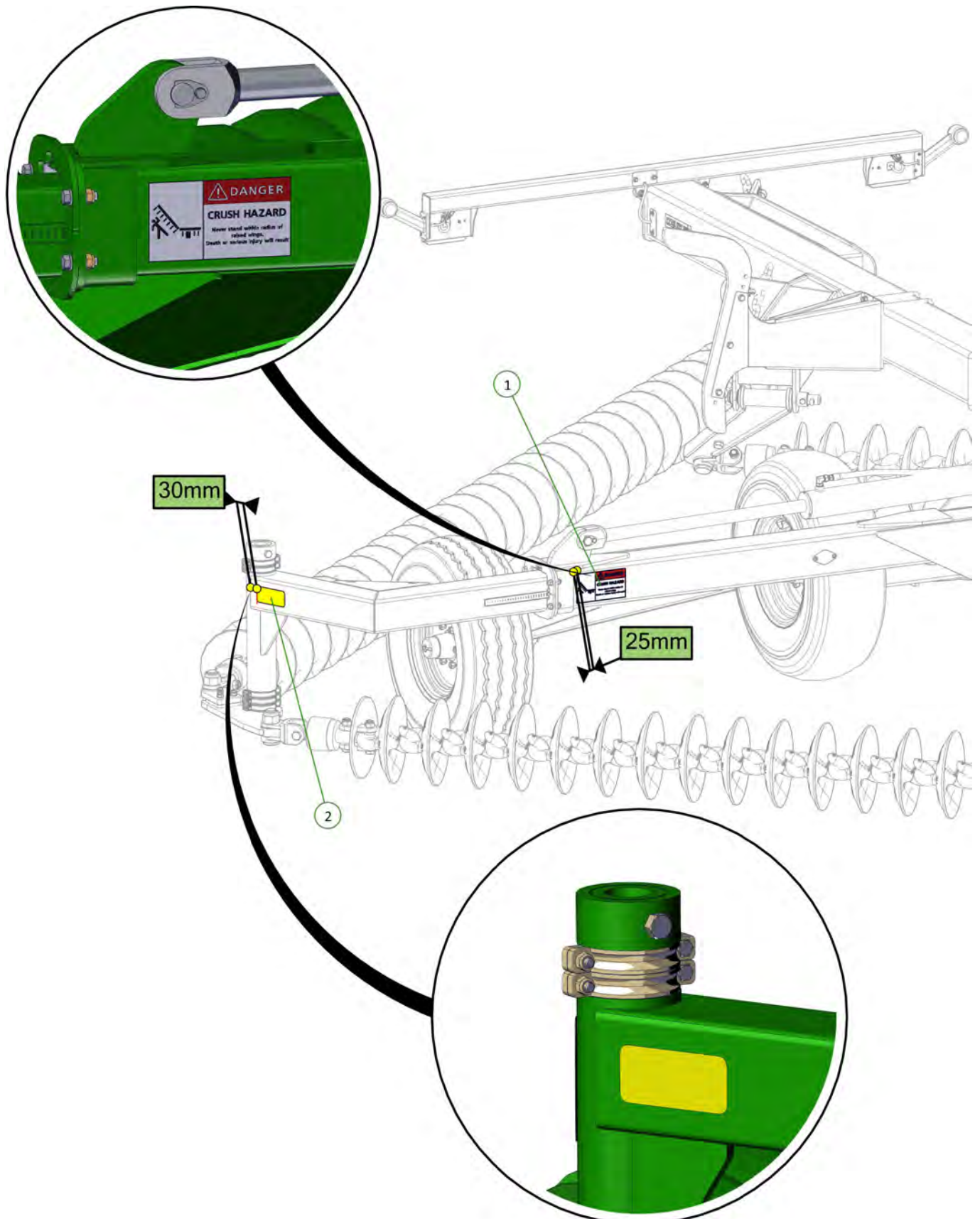

Item No.	Description	Number	Qty
1	Danger Crush Hazard Decal	0801-S3	1
2	Yellow Reflective Decal	0801-SYRF	1

Item No.	Description	Number	Qty
1	Pinch Point Decal	0801-S17	1

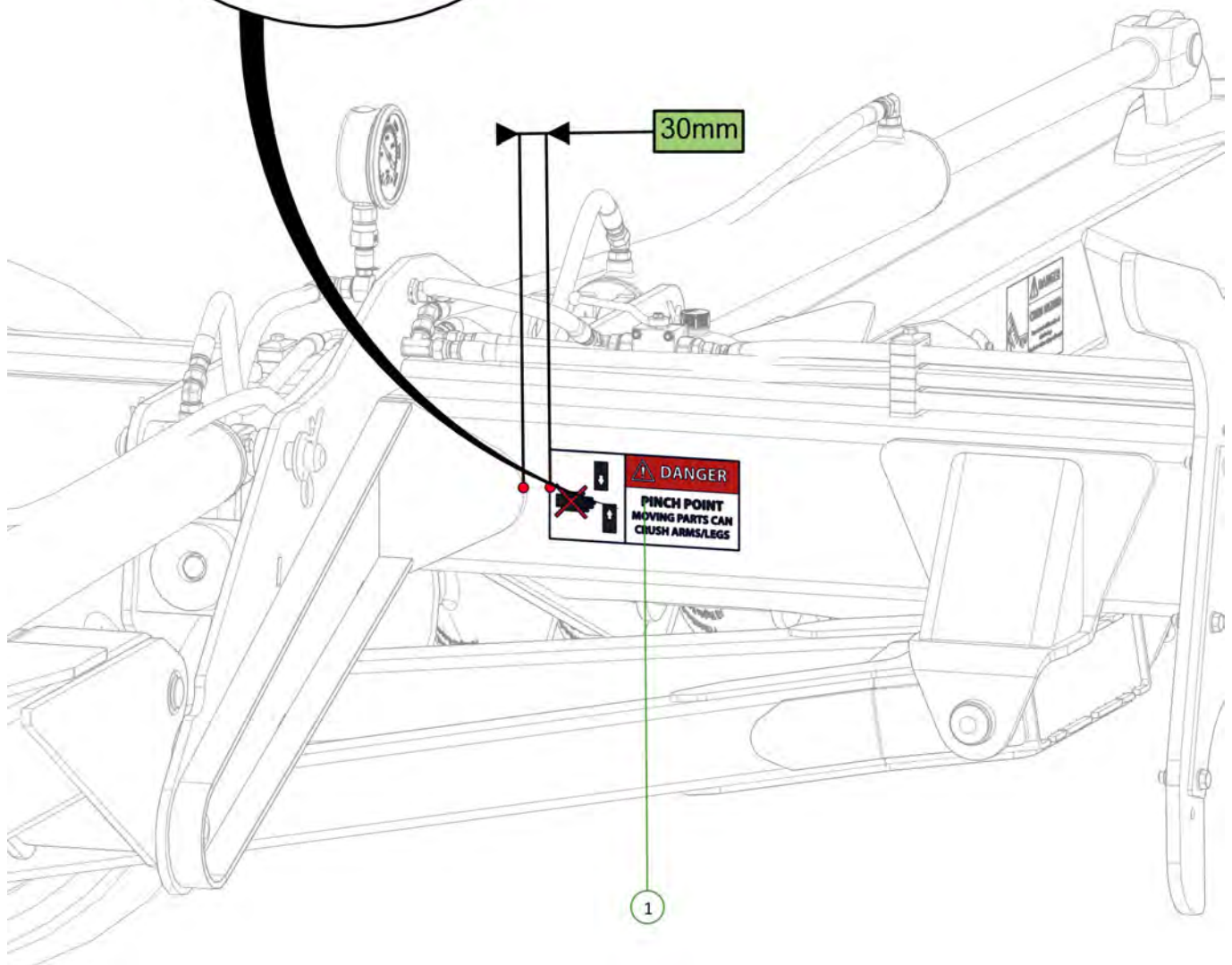

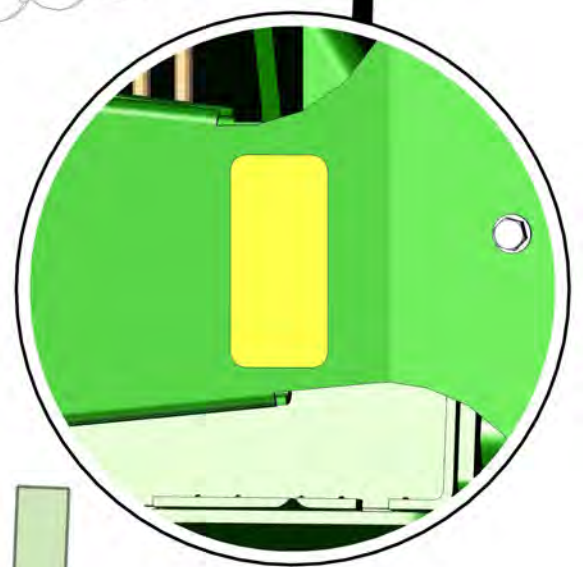
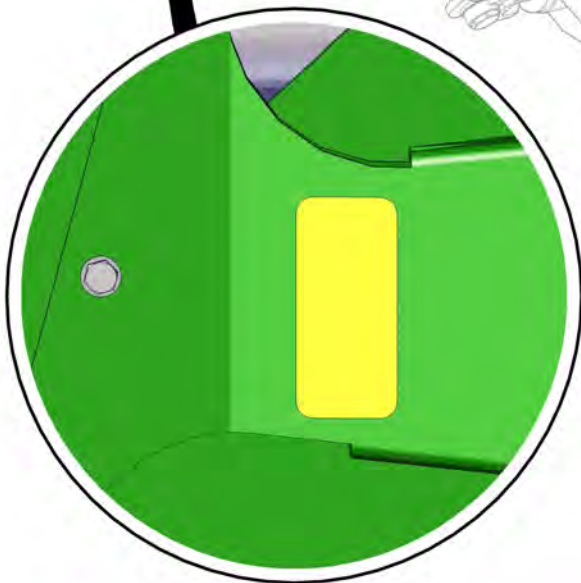
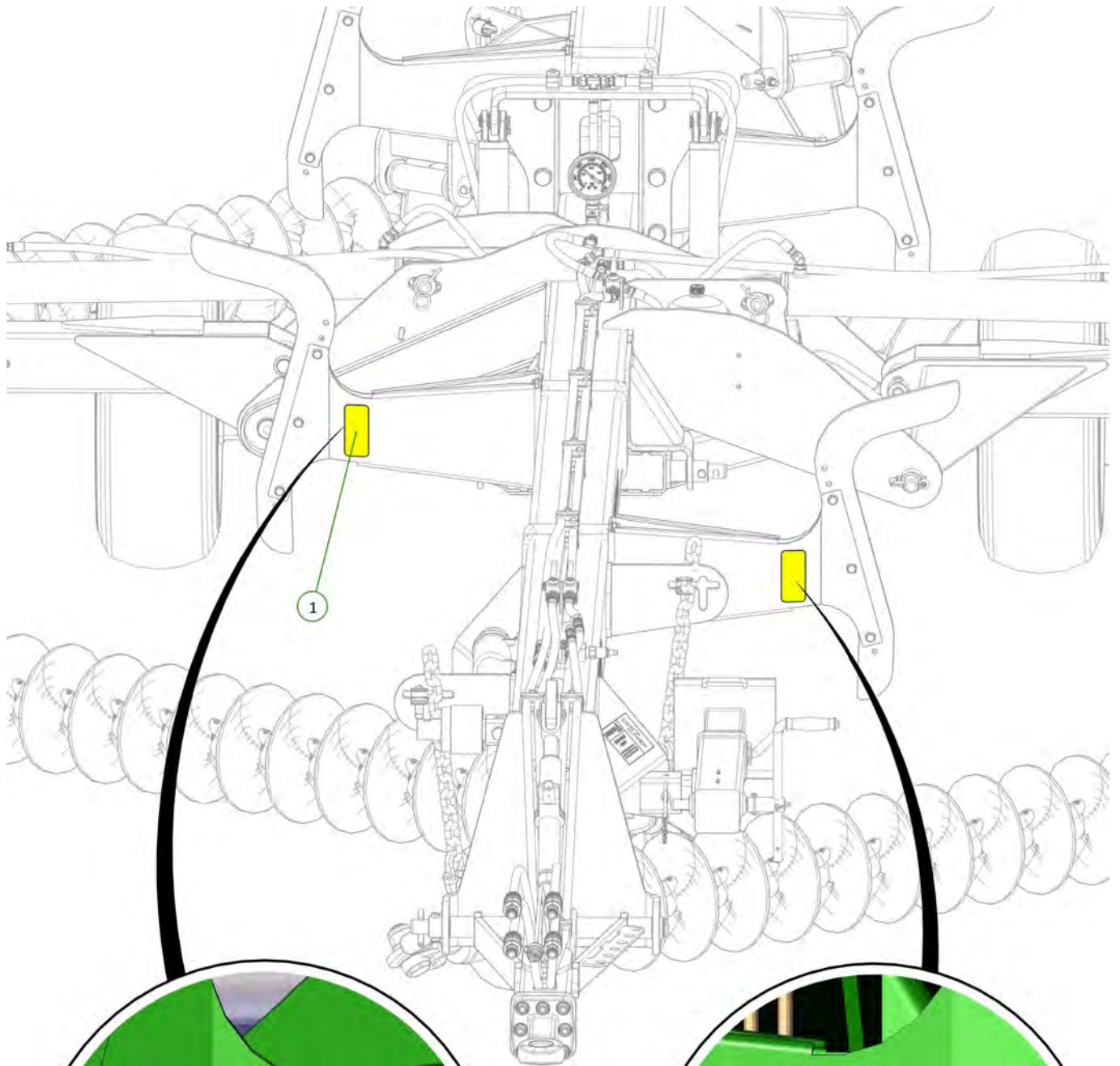

Item No.	Description	Number	Qty
1	Yellow Reflective Decal	0801-SYRF	2

Item No.	Description	Number	Qty
1	Kelly Tillage 2006 Decal	0801-SKT2006	1

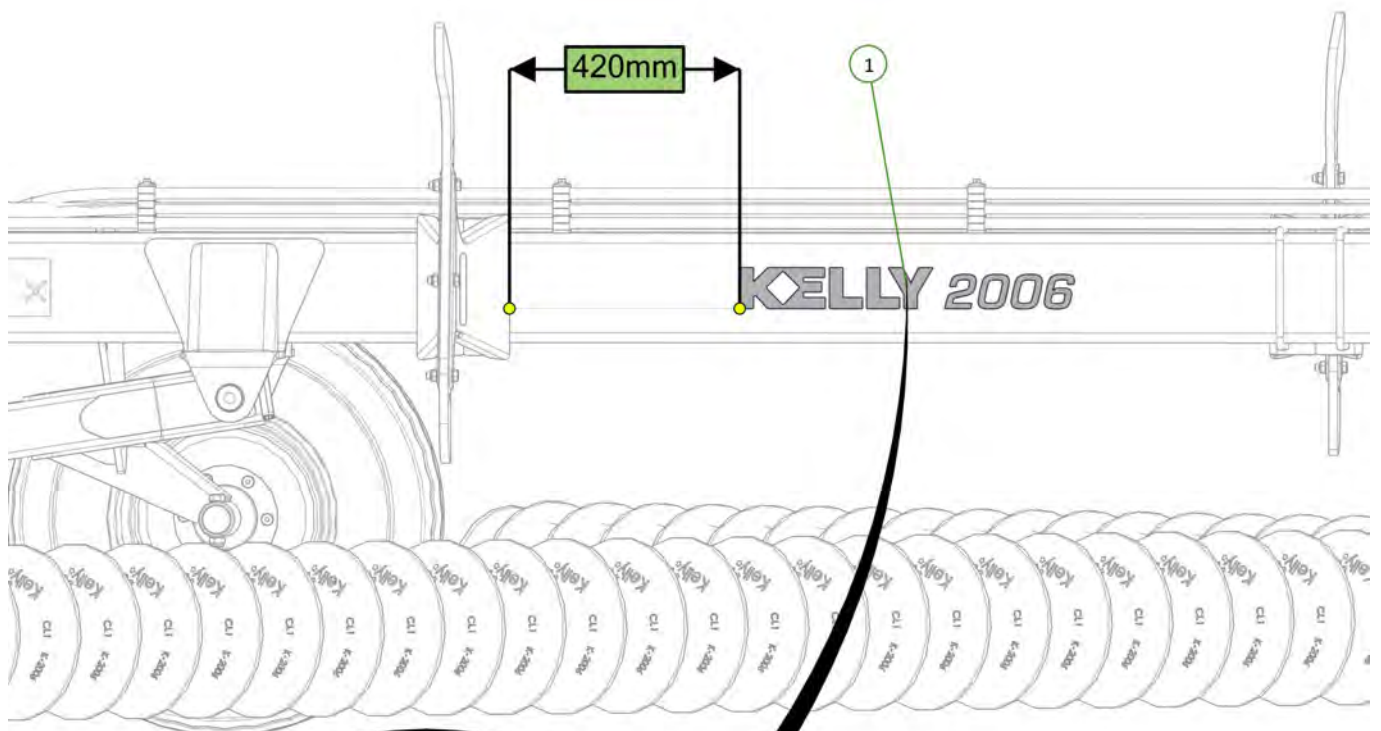
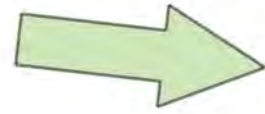

Item No.	Description	Number	Qty
1	Wheel Nut Decal	0801-S9	2
2	Decal- 11L-15 Tyre Inflation	0801-S8-11L-15	2

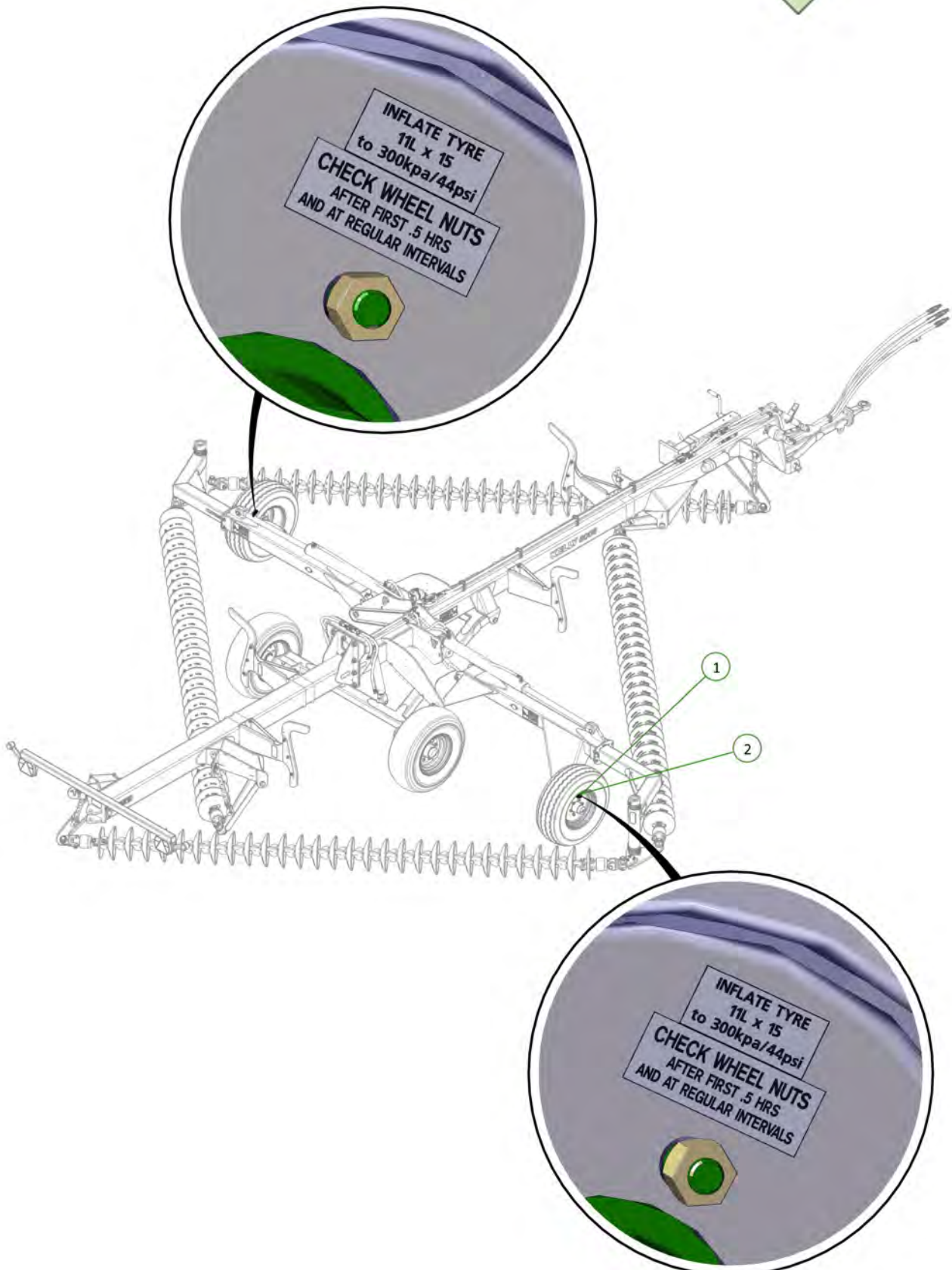



Section 6 - Chain Assembly

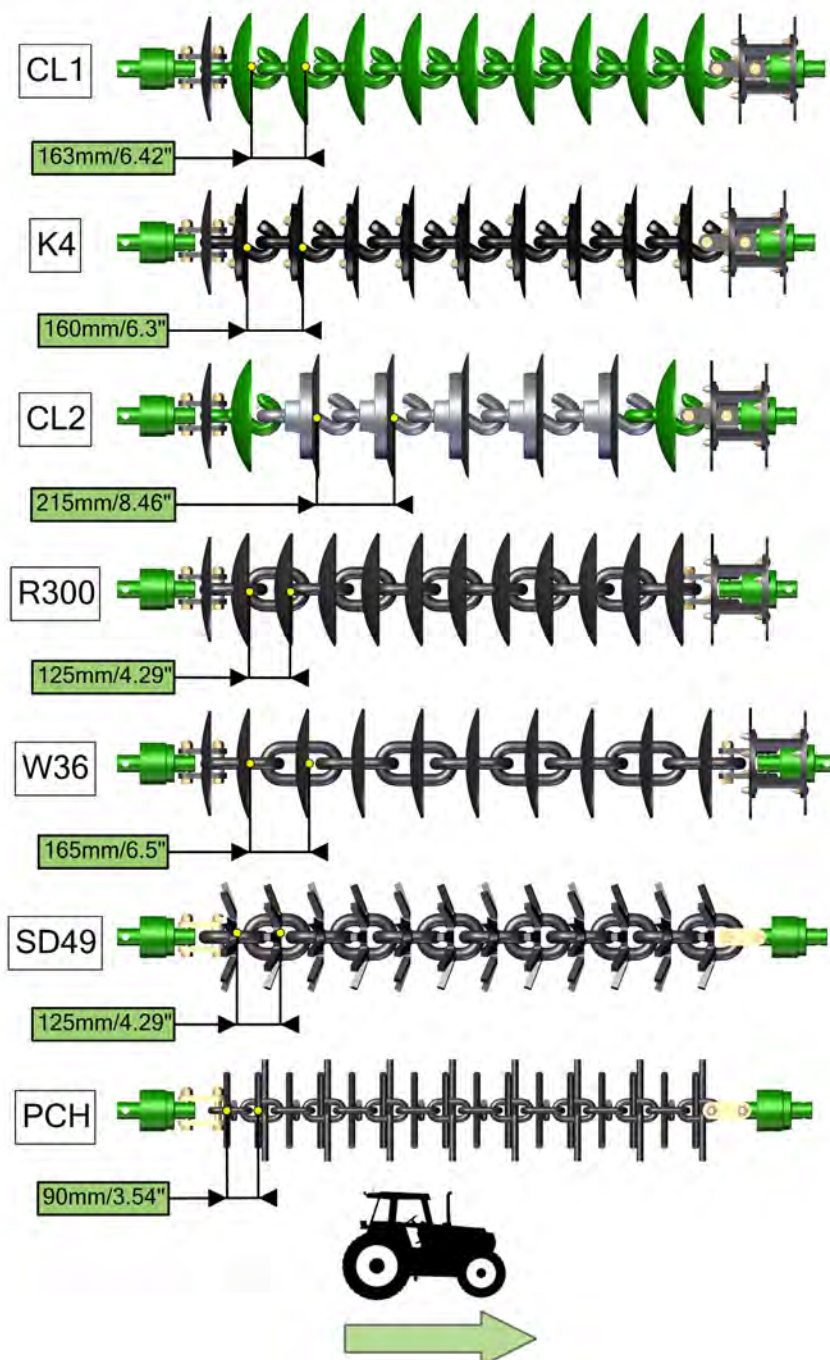

CL1 Disc Chain

Item No.	Description	Number
1	Nyloc Nut M20	0221-NYL20
2	M20 x 110 Class 10.9 ZP Short Thread Bolt	0211-20110ST
3	20mm Bolt Swivel Unit	0802-PCHB55
4	Tie Plate Disc 20mm	0802-DCTP-20
5	Disc Chain Spacer	0801-253755
6	Roll Pin Zinc Plated 3/8" x 2"	0262-3-8X2
7	CL1-B Chain Disc Link	0803-CL1

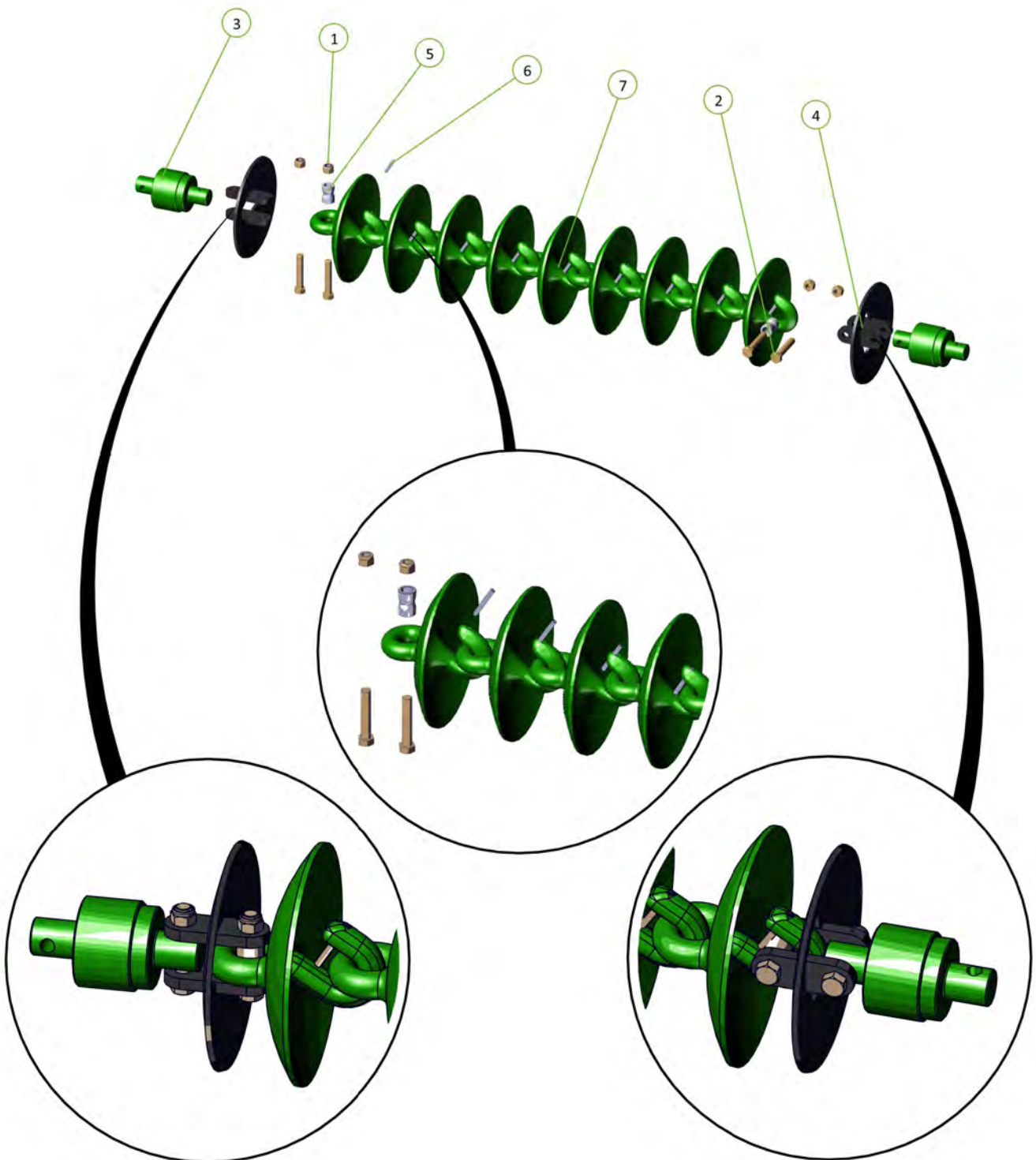

K4 Disc Chain

Item No.	Description	Number
1	Nyloc Nut M20	0221-NYL20
2	M20 x 110 Class 10.9 ZP Short Thread Bolt	0211-20110ST
3	20mm Bolt Swivel Unit	0802-PCHB55
4	Tie Plate Disc 20mm	0802-DCTP-20
5	Disc Chain Spacer	0801-253755
6	K4 Disc Assembly	0803-K4
7	M12 x 55 Class 8.8 ZP Bolt	0211-1255
8	Nyloc Nut M12	0221-NYL12

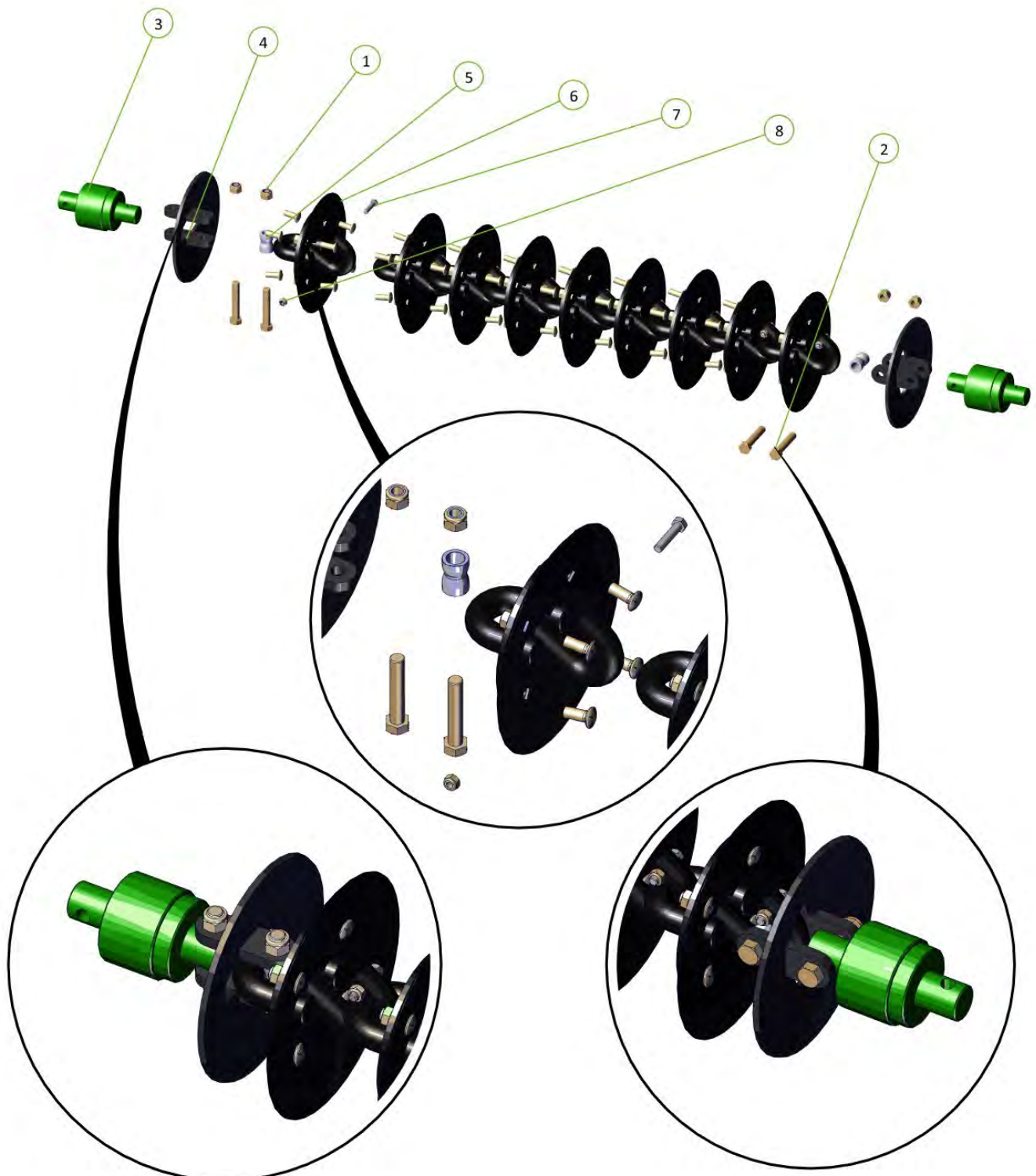

CL2 Disc Chain

Item No.	Description	Number
1	Nyloc Nut M20	0221-NYL20
2	M20 x 110 Class 10.9 ZP Short Thread Bolt	0211-20110ST
3	20mm Bolt Swivel Unit	0802-PCHB55
4	Tie Plate Disc 20mm	0802-DCTP-20
5	Disc Chain Spacer	0801-253755
6	CL2-Link Assembly	0803-CL2
7	Roll Pin Zinc Plated 3/8" x 2"	0262-3-8X2
8	CL1 Disc Chain Link	0803-CL1

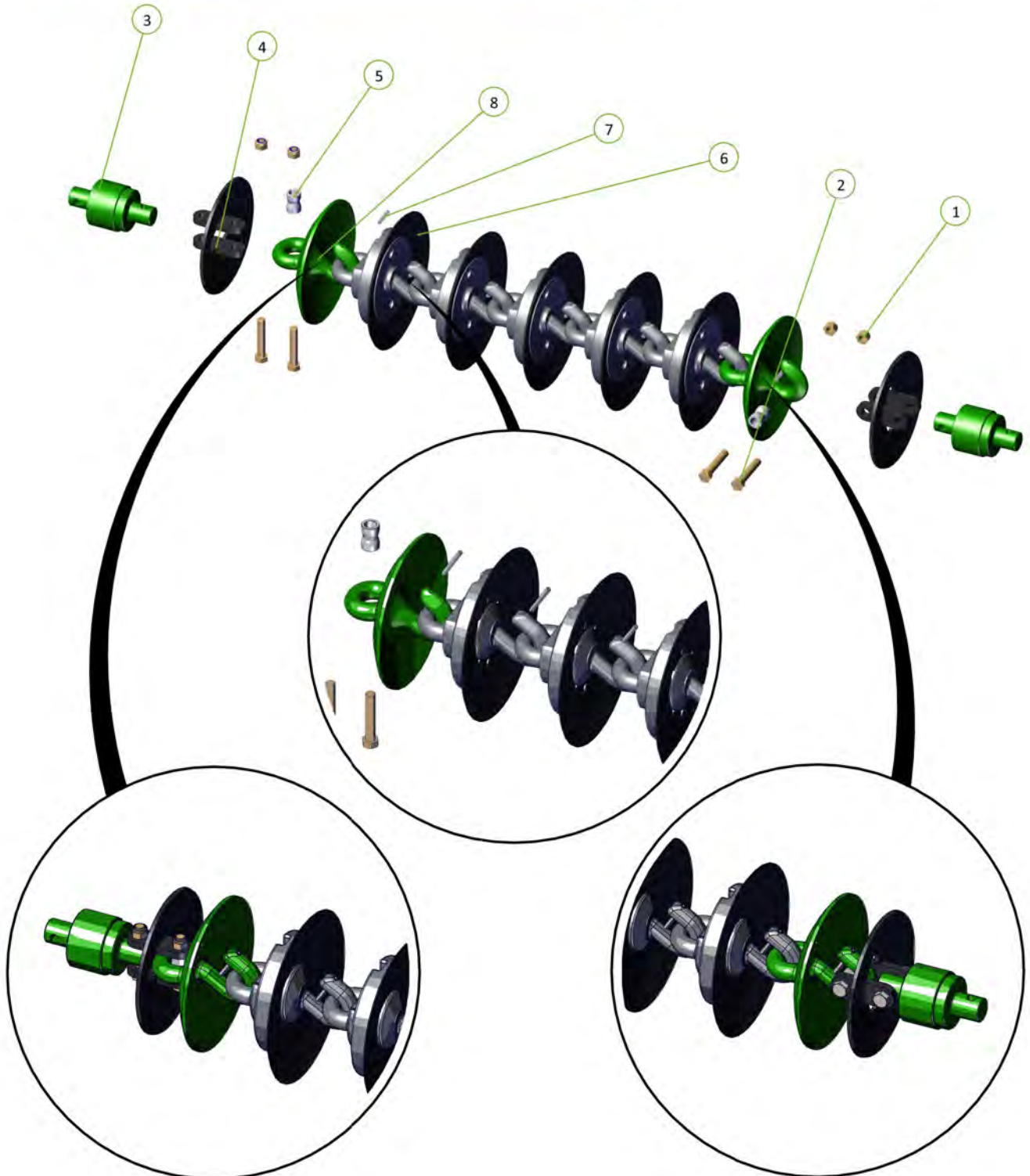
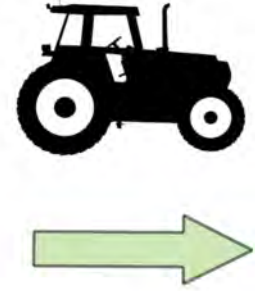

W36 Disc Chain

Item No.	Description	Number
1	Nyloc Nut M20	0221-NYL20
2	M20 x 110 Class 10.9 ZP Short Thread Bolt	0211-20110ST
3	20mm Bolt Swivel Unit	0802-PCHB55
4	Tie Plate Disc 20mm	0802-DCTP-20
5	Disc Chain Spacer	0801-253755
6	W36/25 Chain Link	0803-W36

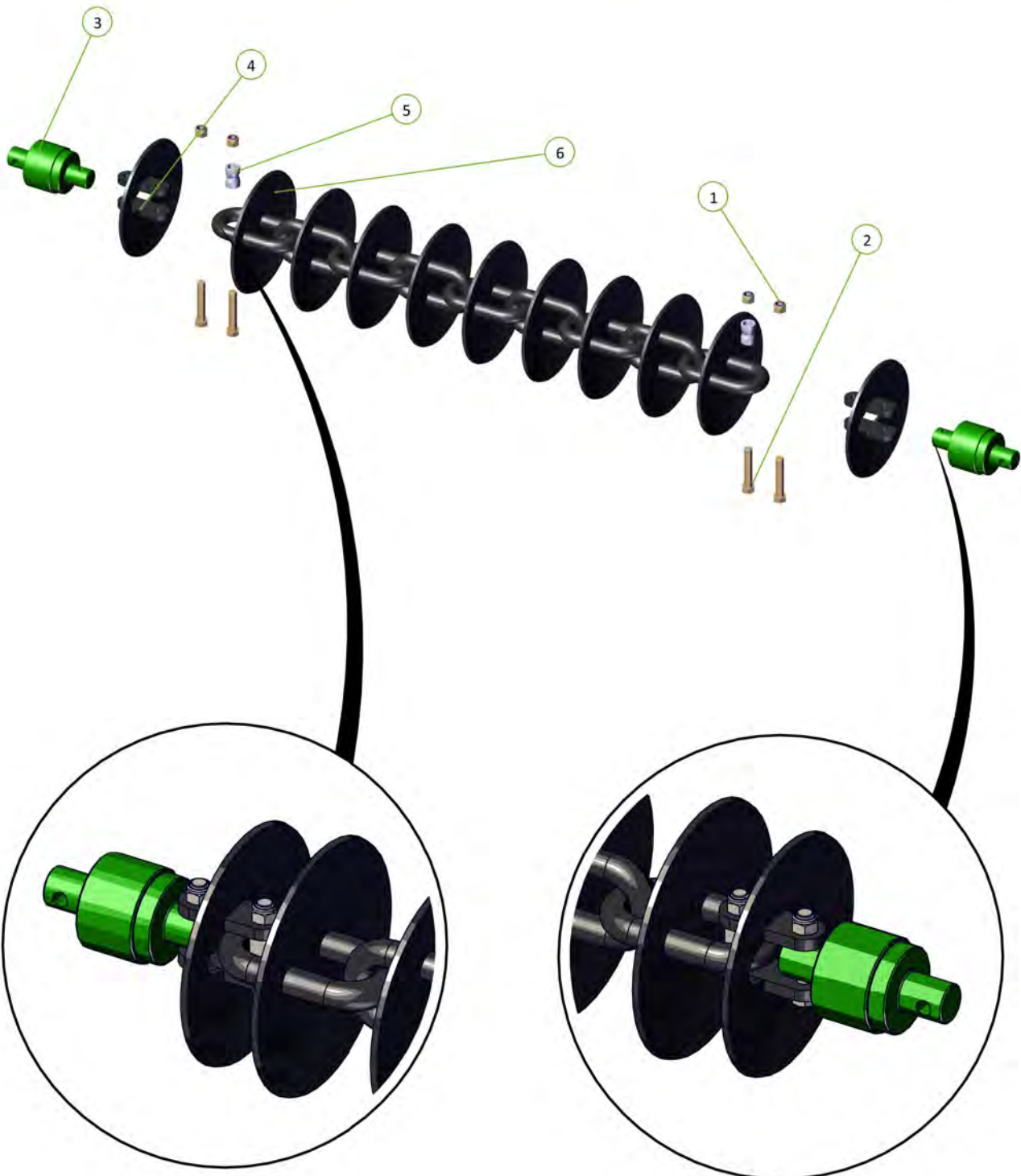

Spike Disc Chain

Item No.	Description	Number
1	Nyloc Nut M20	0221-NYL20
2	M20 x 110 Class 10.9 ZP Short Thread Bolt	0211-20110ST
3	20mm Bolt Swivel Unit	0802-PCHB55
4	Tie Plate For 20mm Bolt	0800-83.2
5	Disc Chain Spacer	0801-253755
6	10 Spike Disc Chain 49/27/5	0803-SD49

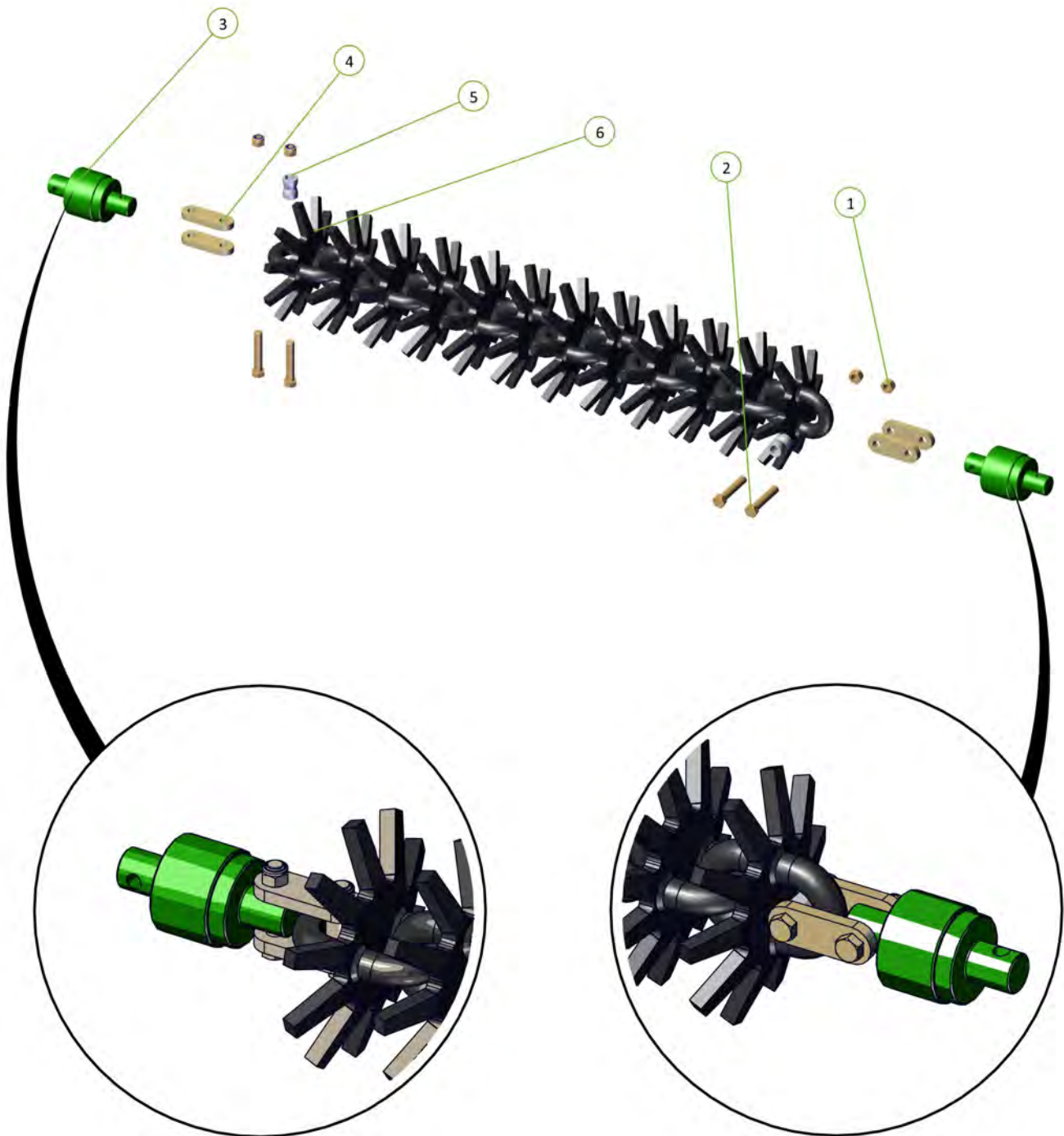
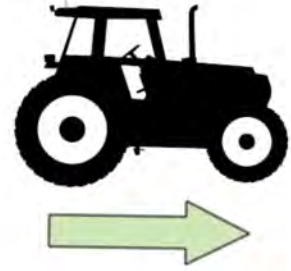

Prickle Chain

Item No.	Description	Number
1	Nyloc Nut M20	0221-NYL20
2	M20 x 110 Class 10.9 ZP Short Thread Bolt	0211-20110ST
3	20mm Bolt Swivel Unit	0802-PCHB55
4	0800-83.2	0800-83.2
5	Prickle Chain	0803-PCH

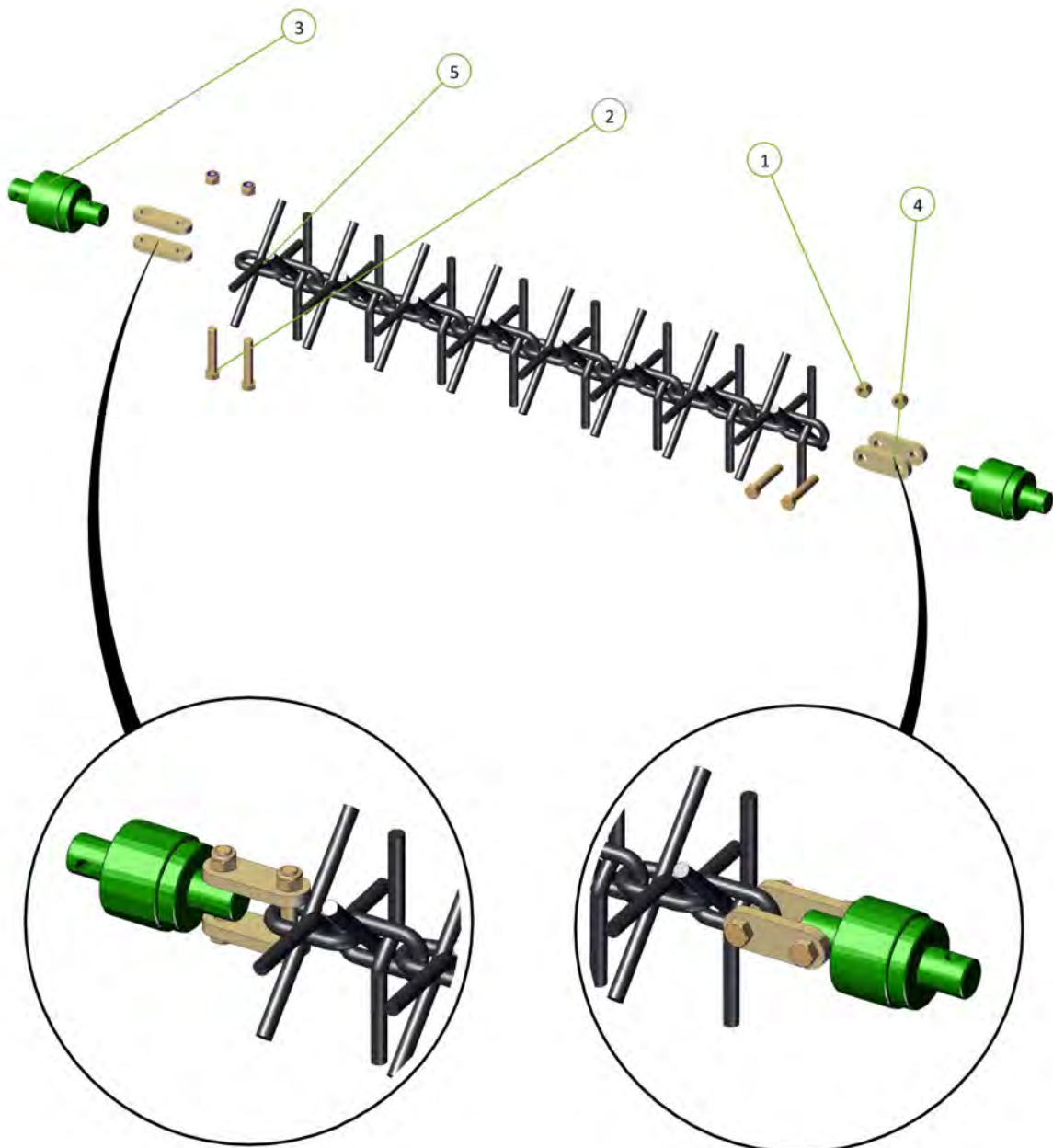



Section 7 - Specifications

Operating speeds

Recommended operating speeds in normal conditions with all chain types	
Operating / working speed	(6-8 mph) / (10-12 km/h)
Transporting / towing speed	(16 mph) / (25 km/h)

Tyre pressure

Tyre size	Ply	KPA	PSI
11.5/80-15.3	14	250	36
11L-15	10	300	44

2006 specifications

Model 2006 Set at	2006
Operating width	6.4m
Transport width	2.4m
Transport height	3.9m
Transport length	10.4m

Disc Chain lengths and Quantities

Model		Length	K4	CL2	CL1	W36	R300	SD49	PCH
				CL2 disc chain also requires CL1 disc chain					
2006	Front Left	4.53m	29	CL2 - 19 CL1 - 2	28	26	36	36	50
	Front Right	4.53m	28	CL2 - 19 CL1 - 2	28	26	36	36	50
	Rear Right	4.60m	29	CL2 - 20 CL1 - 2	28	27	37	37	51
	Rear Left	4.62m	29	CL2 - 20 CL1 - 2	28	27	37	37	51

For correct chain tension, chain links may need to be removed from the end of the chain as follows:

K4 Disc Chain - unhook disc chain link/s from end of the disc chain

CL1 Disc Chain - unhook disc chain link/s from end of the disc chain

W36 Disc Chain - cut a disc chain link from the end of the disc chain

R300 Disc Chain - cut a disc chain link from the end of the disc chain

Spiked Disc Chain - cut a disc chain link from the end of the disc chain

Prickle Chain - cut a prickle chain link from the end of the prickle chain

Scan the following QR code to open the removing a welded disc chain video.



Bolt torque settings

Bolt Type	Wheel nut				U Bolt			Class 8.8 Bolt					Class 10.9 Bolt		Grade 8 Bolt
Bolt Size	M18	M20	1/2"	9/16"	M10	M12	M16	M10	M12	M16	M20	M24	M20	M24	1" UNF
Ft lb	255	265	90	100	22	36	55	32	48	140	190	270	300	350	849
Nm	345	360	125	140	30	50	75	44	65	190	260	370	406	475	1151

[1] When fitting a wheel and tyre to a hub, tighten the wheel nuts in a star pattern to the correct tension. To achieve this, choose a wheel nut & tighten, then proceed to the opposite side of the hub to the next wheel nut and tighten and so on until all wheel nuts are tight. Then repeat the procedure to check that all nuts are tight. Do not use impact tools to tighten wheel nuts.

For a guide to the correct tension of the wheel nuts please use the appropriate tension for your size wheel nuts from the Bolt Torque Settings table.

Torque values are for dry threads and surfaces however it is permissible to apply a small amount of anti-corrosive oil to the threads.

Verification and recording of the prescribed torque settings in the table above is the responsibility of the assembler and it shall be documented in accordance with their approved Quality Assurance system

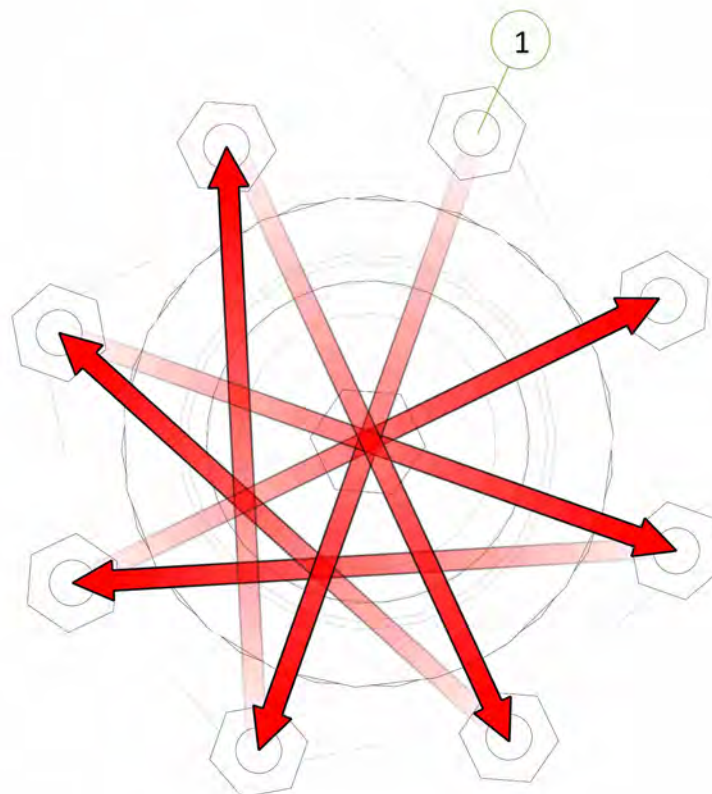



Phone +61 8 8667 2253
Email sales@kellytillage.com
kellytillage.com

Booleroo (Head Office)
684 Kelly Road,
Booleroo Centre SA 5482

Adelaide Office
28 Greenhill Road,
Wayville SA 5034

