



Better Tillage. Better Tomorrow.

KEPM-C-01072023

Hydraulic Cylinder

PARTS MANUAL

Hydraulic Cylinder Reference and Service Guide

Revision C-1

SERIAL NUMBER:



Phone +61 8 8667 2253
Email sales@kellytillage.com
kellytillage.com

Boomeroo (Head Office)
684 Kelly Road,
Boomeroo Centre SA 5482

Adelaide Office
28 Greenhill Road,
Wayville SA 5034





Thank you for choosing a KELLY product.

We trust that you find the following manual clear and easy to follow. If you should require additional customer support or assistance, please do not hesitate to contact us.

Spare parts can be purchased, as required, through your local dealer or by contacting KELLY directly.

The KELLY team values your feedback. Should you have any difficulties that you wish to raise, suggestions for improvement or modifications that you feel would enhance our products we look forward to hearing from you.

Contact Us

Australia

Booleroo (Head Office)

684 Kelly Road,
Booleroo Centre SA 5482

+61 8 8667 2253

Monday - Friday
8am - 4pm ACDT

Adelaide Office

28 Greenhill Road,
Wayville SA 5034

+61 8 8667 2253

Monday - Friday
8am - 4pm ACDT

Global Locations

Eastern Canada

Leading Edge Equipment
www.leadingedgeequipment.ca

1-519-421-3223

Monday - Friday
8am - 4pm EST

Europe

kellytillage.com

+61 8 8667 2253

Monday - Friday
8am - 4pm ACDT

Western Canada

Adair Sales & Marketing Co Inc
www.adairreps.com

1-306-773-0996

Monday - Friday
8am - 5pm CST

Argentina

Giorgi Sa Maquinarias Agrícolas
www.giorgi.com.ar

+54 3464 493512

Monday - Friday
8am - 5pm ART

United States

Hood & Company

+1 417-865-2100

Monday - Friday
8am - 4pm CST

South Africa

Desmond Whitfield CC

+27 82 567 8245

Monday - Friday
8am - 4pm SAST

Contents

Section 1 - How to Identify Your Cylinder	4
Section 2 - Cylinder Installation and Bleeding Process	5
Section 3 - Cylinders Per Machine	6-7
Section 4 - Hydraulics Supplement Parts Manual Index - Nordon Cylinders	8-32
Section 5 - Hydraulics Supplement Parts Manual Index - EzyFit Cylinders	33-43
Section 6 - Cylinder Service Procedure	44-45

How To Identify Your Cylinder

Identify the cylinder on your frame as either EzyFit (for most older machines) or Nordon (from 2015); in order to reference the appropriate section of this manual.

EzyFit cylinders are identified by their stamping on the barrel clevis, consisting of EF followed by 4 numbers. These four numbers with the prefix of 0311- is the part number of the cylinder.

Nordon cylinders have a decal sticker (with the part number and description) on the clevis end of the barrel. More recent Nordon cylinders are white.



Ezyfit cylinder (0311-2958) with the stamping on the barrel clevis



Nordon cylinder (0311-3524SP) with sticker on barrel



White Nordon cylinders

Cylinder Installation and Bleeding Process

INSTALLATION GUIDE - Ensure the hydraulic cylinder is supported at all time to prevent the piston rod from bending.

1. Ensure cylinder is clean and free from foreign matter.
2. Mount base end of cylinders first, ensuring pins and mounts are well greased.
3. Remove plastic or steel plugs located in the ports.
4. Manually fill the cylinders with system hydraulic oil.
5. Connect hoses to cylinder, leaving fittings slightly loose.
6. Once frames have been assembled and cylinders in position, support the barrel of the cylinder in an elevated position so the rod will not collide with mountings (see drawing).
7. Using the hydraulic control lever, bleed the air out of the lines, then tighten the base side hydraulic hose fitting.
8. Operate the controls on slowest flow speed possible to extend cylinder. Bleed the air from the retract side hoses then tighten the hose end fitting and fully retract the cylinders.
9. Operate the controls and fully cycle all cylinders to ensure all air is bled from the system. This may take several cycles.
10. Extend the rod ends out to the mounting points and connect the pins.
11. Remove the cylinder support and cycle the machine through full operation, checking /adjusting for the proper folding operation as per Kelly operator's manual.

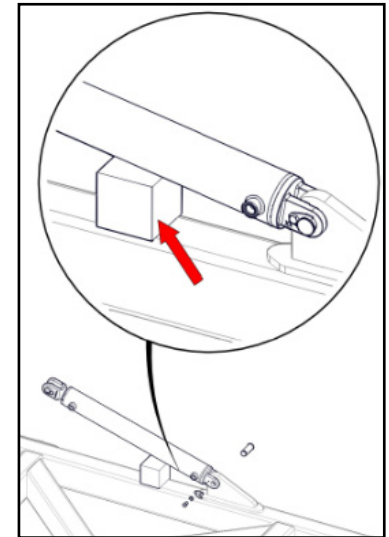

Step 6

PLEASE NOTE:

1. Take care when connecting mounts that no side load is applied to the cylinders, as shaft damage will occur.
2. Ensure mounting pins align.

Cylinders Per Machine

Model 1204		
Part Number	Location	Quantity
0311-316SP	Wing and Wheel Arm Frame	4

Model 2006		
Part Number	Location	Quantity
0311-220SADC	Chain Tensioning - Outer Wing	2
0311-2516	Wheel Arm Frame	2
0311-3532ST	Inner Wings	2

Model 3009		
Part Number	Location	Quantity
0311-256SP	Module Lift	3
0311-312EXT	Drawbar	1
0311-3524SP	Rear Tail	2
0311-430ST	Inner Wings	2

Model 3009NT		
Part Number	Location	Quantity
0311-256SP-WT	Chain Tensioning	2
0311-256SP	Module Lift	3
0311-312EXT	Drawbar	1
0311-3524SP	Outer Wings	2
0311-416SP	Rear Tail	1
0311-530ST	Inner Wings	2

Model 4012		
Part Number	Location	Quantity
0311-256SP	Module Lift	3
0311-412EXT-2	Drawbar	1
0311-424	Rear Tail	1
0311-430ST-C2	Outer Wings	2
0311-536ST	Inner Wings	2

Model 40		
Part Number	Location	Quantity
0311-256SP	Module Lift	3
0311-312EXT	Drawbar	1
0311-324STSP	Left Hand Outer Wing	2
0311-3524SP	Rear Tail	2
0311-424	Right Hand Outer Wing	1
0311-530ST	Inner Wings	2

Model 45		
Part Number	Location	Quantity
0311-5040	Inner Wings	2
0311-6357	Drawbar	1
0311-2958	Rear Tail	2
0311-2957	Outer Wings	4
0311-5041	Module Lift	3

Cylinders Per Machine

Model 4614		
Part Number	Location	Quantity
0311-256SP	Module Lift	3
0311-324STSP	Outer Wings	4
0311-412EXT-2	Drawbar	1
0311-424	Rear Tail	1
0311-530STSP	Inner Wings	4

Model 6218HDX		
Part Number	Location	Quantity
0311-256SP	Module Lift	3
0311-3524SP	Rear Tail	2
0311-3532ST	Outer Wings	4
0311-412EXT-2	Drawbar	1
0311-536ST	Inner Wings	4

Model 6218		
Part Number	Location	Quantity
0311-256SP	Module Lift	3
0311-308SPOC	Hydraulic Jack	2
0311-3524SP	Rear Tail	2
0311-3532ST	Outer Wings	4
0311-412EXT-2	Drawbar	2
0311-536ST	Inner Wings	4

Model 8024		
Part Number	Location	Quantity
0311-256SP	Module Lift	3
0311-308SPOC	Hydraulic Jack	2
0311-3524SP	Rear Tail	2
0311-412EXT-2	Drawbar	2
0311-6X36-4ST	Inner & Outer Wings	8

Hydraulic Cylinder Supplement Parts Manual Index - Nordon Cylinders



Page No.	Part No.	Replaces Part No.	Seal Kit No.	Description	Machine Model & Machine Area
9	0311-220SADC		0312-N2	2" Bore x 20" Stroke 1.75" Rod Single Acting Displacement Cylinder	2006 x 2 (outer wing chain tensioners)
10	0311-208SADC		0312-N2	2" Bore x 8" Stroke 1.75" Rod Single Acting Displacement Cylinder	2006 x 2 (outer wing chain tensioners)
11	0311-2506EXT		0312-N25	2.5" Bore x 6" Stroke	12X x 1 (front lift)
12	0311-256SP	0311-5041	0312-N25	2.5" Bore x 6" Stroke 1.5" Rod Side Port Cylinder	All Models x 3 (module lift)
13	0311-256SP-WT		0312-N25	2.5" Bore x 6" Stroke x 1.5" Rod Side Port Wing Tensioner	Upgrade to 3009NT & 4614 x 2 (rear chain wing detensioners)
14	0311-2516		0312-N25	2.5" Bore x 16" Stroke Hydraulic Cylinder	2006 & 12X x 2 (wheel arm lift)
15	0311-308SPOC		0312-N3-S	3" Bore x 8" Stroke Cylinder with Int DCBV Valve	6218 x 1; 6218HDX & 8024 x 2 (hydraulic jack)
16	0311-316SP		0312-N3-S	3" Bore x 12" Stroke 1.5" Rod Side Port Hydraulic Cylinder	1204 x 4 (wings & wheel arm lift)
17	0311-324STSP	0311-324SP 0311-324	0312-N3-S	3" Bore x 24" Stroke 1.5" Rod Cylinder with Stop Tube & Side Port	40 x 2 (left hand outer wing); 4614 x 4 (both outer wing)
18	0311-324	0311-2957	0312-N3-S	3" Bore x 24" Stroke 1.5" Rod Cylinder	45' x 4 (outer wing), 4614 x 4 (outer wing)
19	0311-3524SP	0311-2958	0312-N35-S	3.5" Bore x 24" Stroke 1.75" Rod Side Port Cylinder	3009NT x 2 (each outer wing) 3009, 40, 4012, 45', 6218, 6218HDX & 8024 x 2 (rear tail)
20	0311-3532ST	0311-6896	0312-N35-S	3.5" Bore x 32" Stroke 1.75" Rod Cylinder with 4" Stop Tube	2006 x 2 (main wings) 6218CT & 6218HDX x 4 (both outer wings)
21-22	0311-312EXT	0311-6002	0312-N3-S	3" Bore x 12" Stroke 1.5" Rod Extended Cylinder	3009NT, 3009, 40 & 4012 x 1 (front lift cylinder)
23	0311-412EXT	0311-6357	0312-N4-S	4" Bore x 12" Stroke 1.75" Rod Extended Cylinder	45' & 50 (front lift)
24	0311-412EXT-2	0311-412EXT	0312-N4-2	4" Bore x 12" Stroke 2" Rod Extended Cylinder	4012, 4614 & 6218 x 1 (front lift) 6218HDX & 8024 x 2 (front lift)
25	0311-416SP		0312-N4-S	4" Bore x 16" Stroke 1.75" Rod Cylinder (Side Port)	3009NT x 1 (rear tail)
26	0311-424	0311-3786	0312-N4-S	4" Bore x 24" Stroke 1.75" Rod Cylinder	4012 & 4614 x 1 (rear tail) 40 x 1 (right hand outer wing)
27	0311-430ST	0311-4781	0312-N4-S	4" Bore x 30" Stroke 1.75" Rod Cylinder with 3" Stop Tube	40 x 1 (right hand outer wing)
28	0311-430ST-C2		0312-N4-S	4" Bore x 30" Stroke 1.75" Rod Cylinder (Clevis) with 3" Stop Tube	4012 x 2 (left hand & right hand outer wing)
29	0311-530ST	0311-5040	0312-N5-S	5" Bore x 30" Stroke 2" Rod Cylinder with 3" Stop Tube	3009NT, 40, 4012 x 2 (main wings), 45' x 2 (Inner wings)
30	0311-530STSP		0312-N5-S	5" Bore x 30" Stroke 2" Rod Cylinder with 3" Stop Tube (Side Port)	4614 x 4 (main wings)
31	0311-536ST	0311-2956	0312-N5-S	5" Bore x 36" Stroke 2" Rod Cylinder with 3" Stop Tube	4012 x 2 ; 6218 & 6218HDX x 4 (main wings)

Superseded

ITEM NO.	PART NUMBER	DESCRIPTION	Revision	QTY.
1	0313-220DISP-B	2" X 20" Displacement Cylinder Barrel		1
2	0312-N2	Nordon 2" Cylinder Seal Kit		1
3	0313-220DISP-R	2" x 20" Displacement Cylinder Rod		1
4	0313-NG2x8DISP	Cylinder Gland 1.75" Rod x 2" Barrel Displacement		1
5	0313-NRC1X1 1-8	Hydraulic Cylinder Rod Clevis 1" Pin 1 1/8" Thread	A-0	1
6	0313-NP2DISP	Nordon 2" Displacement Cylinder Piston		1

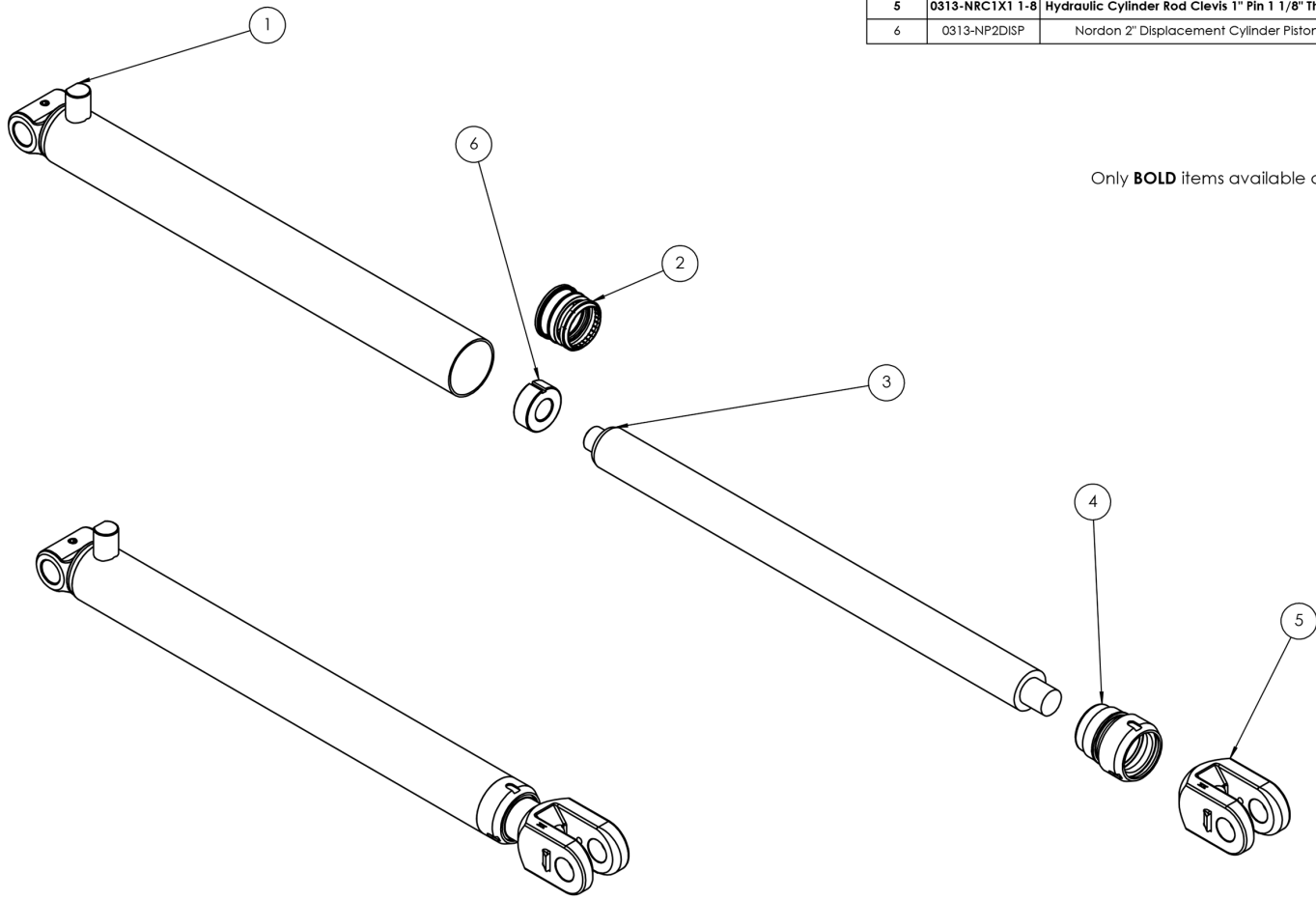

Only **BOLD** items available as spare parts



Part Number	Description	For Machines Built:	Revision
0311-220SADC	2" Bore x 20" Stroke 1.75" Rod Single Acting Displacement Cylinder		B-0

ITEM NO.	PART NUMBER	Description 2	Revision	Qty
1	0211-820	M8 x 20 Class 8.8 ZP Bolt		1
2	0231-S8	Washer Spring M8		1
3	0312-N2	Nordon 2" Cylinder Seal Kit		1
4	0313-10I23M3	Retaining Lug	A-0	1
5	0313-28DISP-B	2" x 8" Displacement Cylinder Barrel		1
6	0313-28DISP-R	2" x 8" Displacement Cylinder Rod		1
7	0313-NCP1X75	Hydraulic Cylinder Pin 1" x 75mm	A-0	1
8	0313-NG2x8DISP	Cylinder Gland 1.75" Rod x 2" Barrel Displacement		1
9	0313-NP2DISP	Nordon 2" Displacement Cylinder Piston		1
10	0313-NRC1X1 1-8	Hydraulic Cylinder Rod Clevis 1" Pin 1 1/8" Thread	A-0	1

Only **BOLD** items available as spare parts

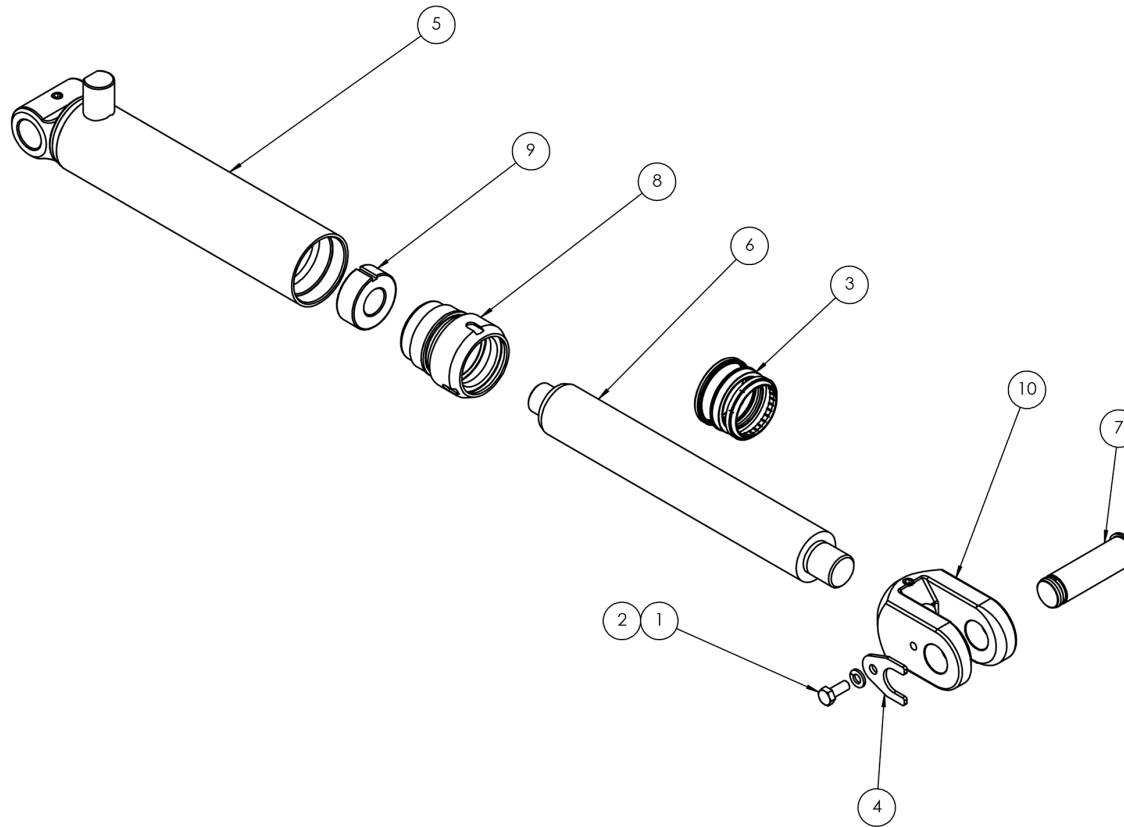

KELLY

Part Number	Description	For Machines Built:	Revision
0311-208SADC	2" Bore x 8" Stroke 1.75" Rod Single Acting Displacement Cylinder		B-0

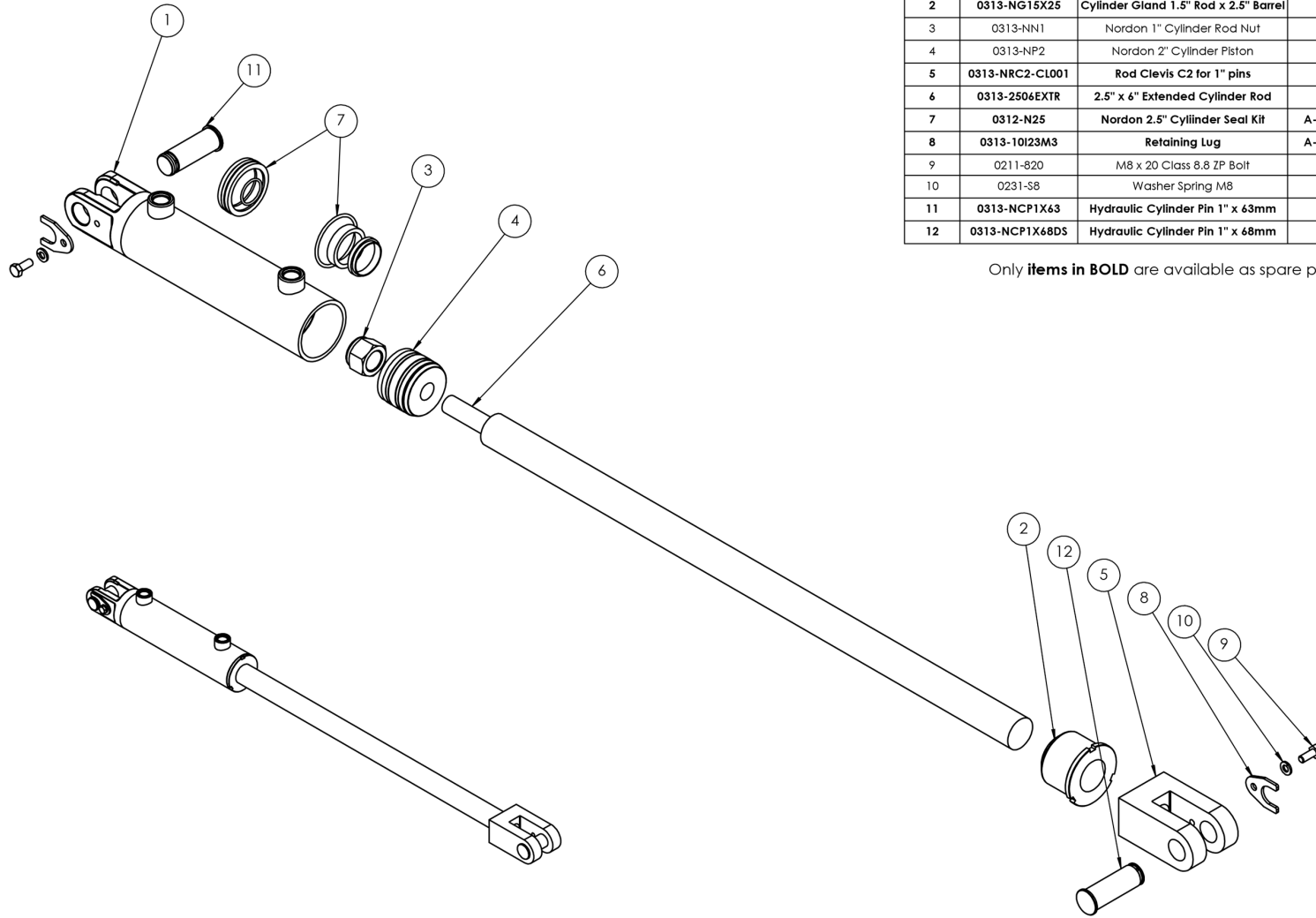

ITEM NO.	PART NUMBER	DESCRIPTION	Revision	QTY.
1	0313-2506EXTB	2.5" Bore x 6" Stroke Cylinder Barrel	A-0	1
2	0313-NG15X25	Cylinder Gland 1.5" Rod x 2.5" Barrel		1
3	0313-NN1	Nordon 1" Cylinder Rod Nut		1
4	0313-NP2	Nordon 2" Cylinder Piston		1
5	0313-NRC2-CL001	Rod Clevis C2 for 1" pins		1
6	0313-2506EXTR	2.5" x 6" Extended Cylinder Rod		1
7	0312-N25	Nordon 2.5" Cylinder Seal Kit	A-0	1
8	0313-10I23M3	Retaining Lug	A-0	2
9	0211-820	M8 x 20 Class 8.8 ZP Bolt		2
10	0231-S8	Washer Spring M8		2
11	0313-NCP1X63	Hydraulic Cylinder Pin 1" x 63mm		1
12	0313-NCP1X68DS	Hydraulic Cylinder Pin 1" x 68mm		1

Only items in **BOLD** are available as spare parts



Part Number	Description	For Machines Built:	Revision
0311-2506EXT	2.5" Bore x 6" Stroke Extended Cylinder		A-1

ITEM NO.	PART NUMBER	Description	Revision	QTY.
1	0211-820	M8 x 20 Class 8.8 ZP Bolt		2
2	0231-58	Washer Spring M8		2
3	0312-N25	Nordon 2.5" Cylinder Seal Kit	A-0	1
4	0313-10I23M3	Retaining Lug	A-0	2
5	0313-256SP-B	2.5" x 6" Hydraulic Cylinder Barrel	A-0	1
6	0313-256SP-R	Shaft for 0311-256SP-WT		1
7	0313-NCP1X63	Hydraulic Cylinder Pin 1" x 63mm		1
8	0313-NCP1X68DS	Hydraulic Cylinder Pin 1" x 68mm		1
9	0313-NG15X25	Cylinder Gland 1.5" Rod x 2.5" Barrel		1
10	0313-NN1	Nordon 1" Cylinder Rod Nut		1
11	0313-NP25	Hydraulic Cylinder Piston 2 1/2"	A-0	1
12	0313-NRC1X1 1-8	Hydraulic Cylinder Rod Clevis 1" Pin 1 1/8" Thread	A-0	1

Only **items in BOLD** are available as spare parts

Note: Replaces Cylinder 0311-5041

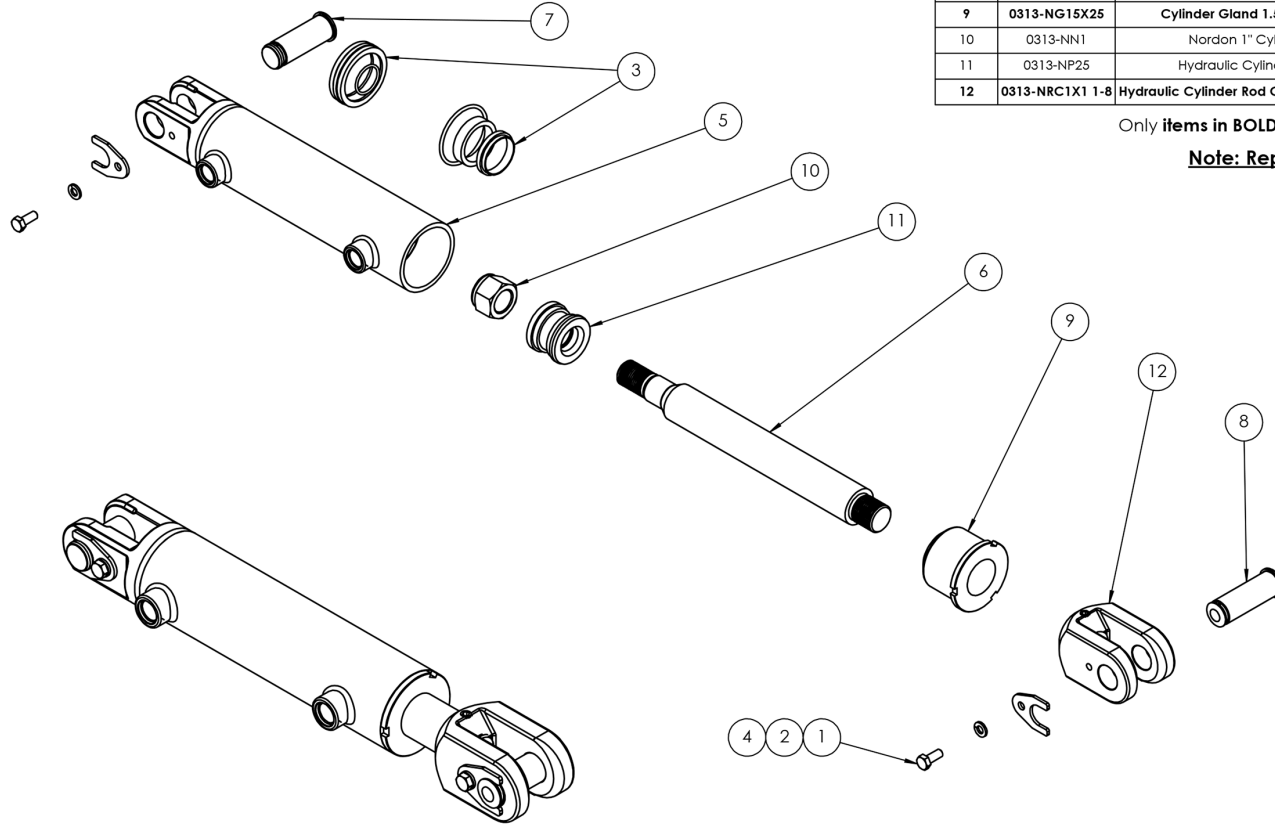

Part Number	Description	For Machines Built:	Revision
0311-256SP	2.5" Bore x 6" Stroke 1.5" Rod Side Port Cylinder		B-0

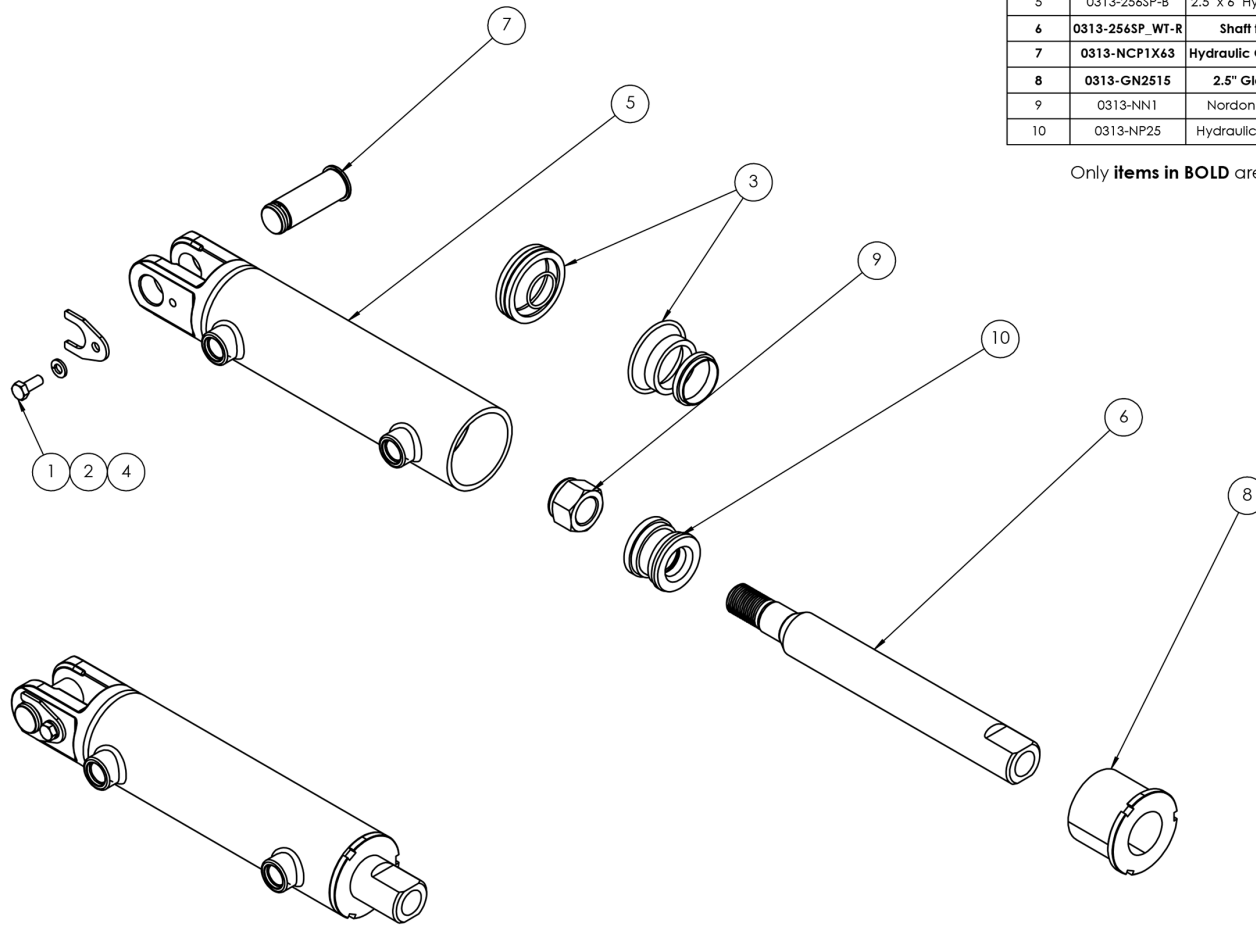

ITEM NO.	PART NUMBER	DESCRIPTION	Revision	QTY.
1	0211-820	M8 x 20 Class 8.8 ZP Bolt		1
2	0231-S8	Washer Spring M8		1
3	0312-N25	Nordon 2.5" Cylinder Seal Kit	A-0	1
4	0313-10I23M3	Retaining Lug	A-0	1
5	0313-256SP-B	2.5" x 6" Hydraulic Cylinder Barrel	A-0	1
6	0313-256SP_WT-R	Shaft for 0311-256SP-WT		1
7	0313-NCP1X63	Hydraulic Cylinder Pin 1" x 63mm		1
8	0313-GN2515	2.5" Gland to suit 1.5" Rod		1
9	0313-NN1	Nordon 1" Cylinder Rod Nut		1
10	0313-NP25	Hydraulic Cylinder Piston 2 1/2"	A-0	1

Only **items in BOLD** are available as spare parts



Part Number	Description	For Machines Built:	Revision
0311-256SP-WT	2.5" Bore x 6" Stroke x 1.5" Rod Side Port Wing Tensioner		B-0

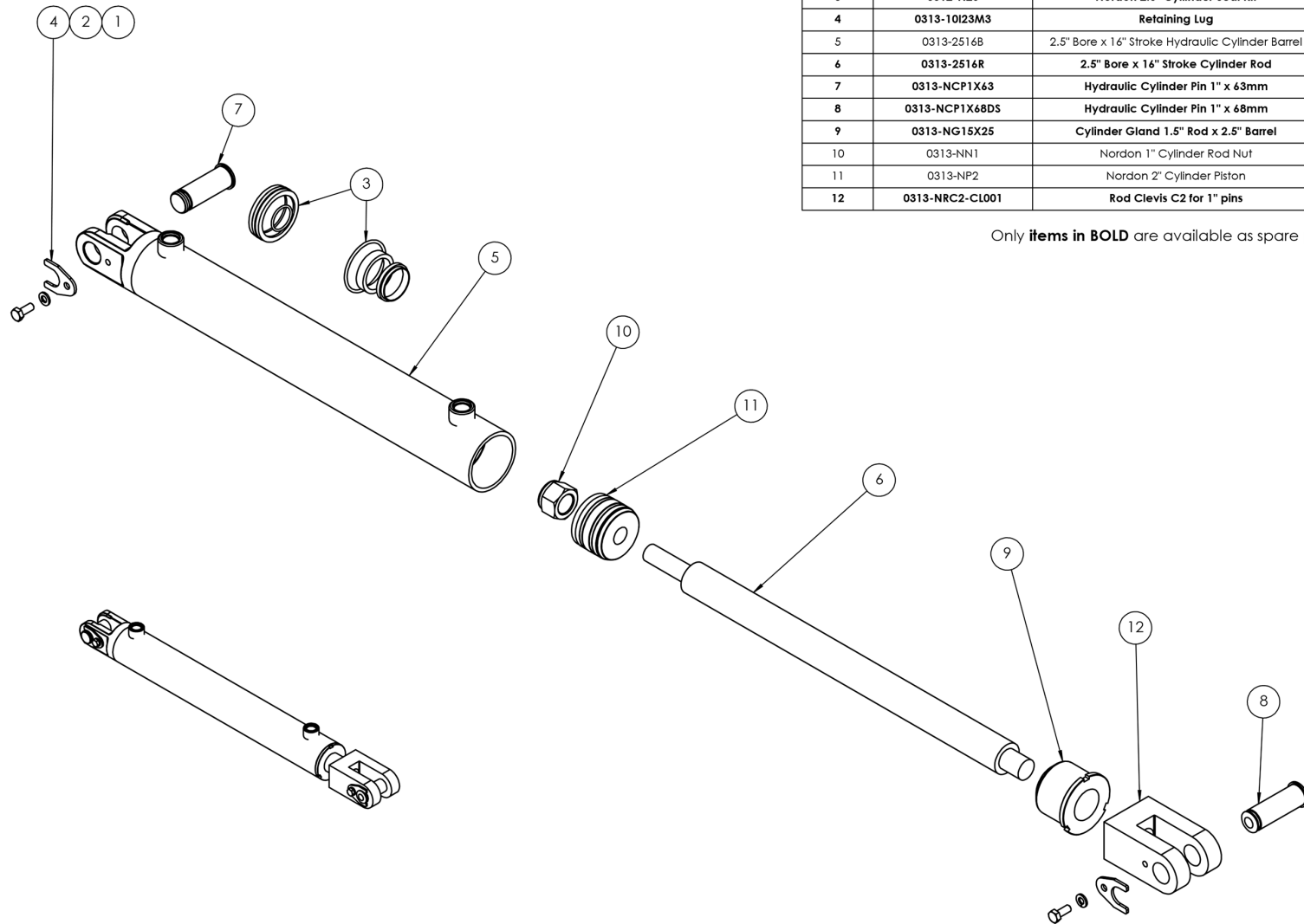

ITEM NO.	PART NUMBER	DESCRIPTION	QTY.
1	0211-820	M8 x 20 Class 8.8 ZP Bolt	2
2	0231-S8	Washer Spring M8	2
3	0312-N25	Nordon 2.5" Cylinder Seal Kit	1
4	0313-10I23M3	Retaining Lug	2
5	0313-2516B	2.5" Bore x 16" Stroke Hydraulic Cylinder Barrel	1
6	0313-2516R	2.5" Bore x 16" Stroke Cylinder Rod	1
7	0313-NCP1X63	Hydraulic Cylinder Pin 1" x 63mm	1
8	0313-NCP1X68DS	Hydraulic Cylinder Pin 1" x 68mm	1
9	0313-NG15X25	Cylinder Gland 1.5" Rod x 2.5" Barrel	1
10	0313-NN1	Nordon 1" Cylinder Rod Nut	1
11	0313-NP2	Nordon 2" Cylinder Piston	1
12	0313-NRC2-CL001	Rod Clevis C2 for 1" pins	1

Only **items in BOLD** are available as spare parts

KELLY

Part Number	Description	For Machines Built:	Revision
0311-2516	2.5" Bore x 16" Stroke Hydraulic Cylinder		B-0

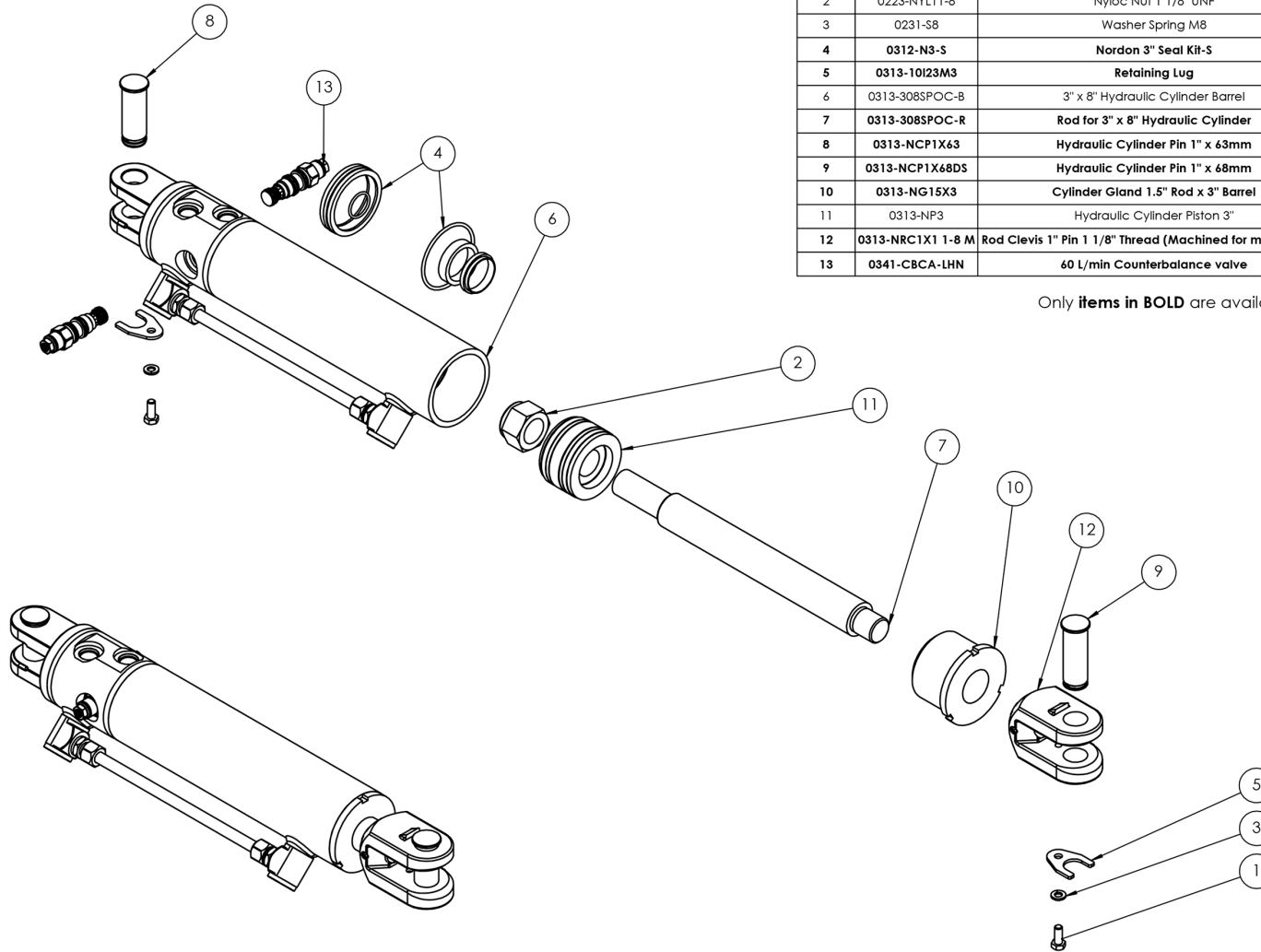

ITEM NO.	PART NUMBER	DESCRIPTION	Revision	QTY.
1	0211-820	M8 x 20 Class 8.8 ZP Bolt		2
2	0223-NYL11-8	Nyloc Nut 1 1/8" UNF		1
3	0231-S8	Washer Spring M8		2
4	0312-N3-S	Nordon 3" Seal Kit-S		1
5	0313-10I23M3	Retaining Lug	A-0	2
6	0313-308SPOC-B	3" x 8" Hydraulic Cylinder Barrel	A-0	1
7	0313-308SPOC-R	Rod for 3" x 8" Hydraulic Cylinder	A-0	1
8	0313-NCP1X63	Hydraulic Cylinder Pin 1" x 63mm		1
9	0313-NCP1X68DS	Hydraulic Cylinder Pin 1" x 68mm		1
10	0313-NG15X3	Cylinder Gland 1.5" Rod x 3" Barrel	A-0	1
11	0313-NP3	Hydraulic Cylinder Piston 3"	A-0	1
12	0313-NRC1X1 1-8 M	Rod Clevis 1" Pin 1 1/8" Thread (Machined for mount plate)	A-0	1
13	0341-CBCA-LHN	60 L/min Counterbalance valve		2

Only **items in BOLD** are available as spare parts



Part Number	Description	For Machines Built:	Revision
0311-308SPOC	3" Bore 8" Stroke NI Cylinder with Int DCBV Valve		D-0

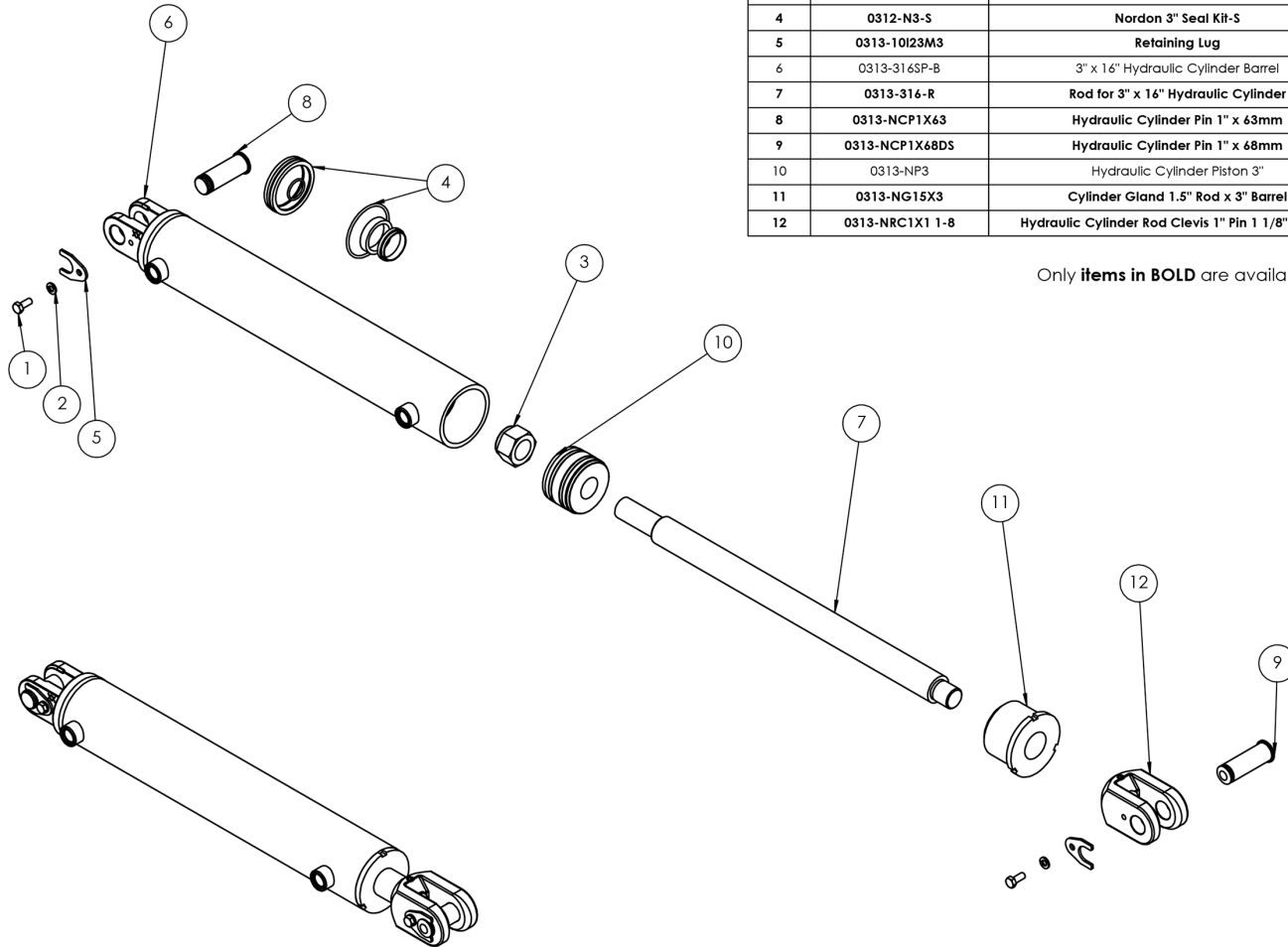

ITEM NO.	PART NUMBER	DESCRIPTION	Revision	QTY.
1	0211-820	M8 x 20 Class 8.8 ZP Bolt		2
2	0231-S8	Washer Spring M8		2
3	0223-NYL1 1-8	Nyloc Nut 1 1/8" UNF		1
4	0312-N3-S	Nordon 3" Seal Kit-S		1
5	0313-10I23M3	Retaining Lug	A-0	2
6	0313-316SP-B	3" x 16" Hydraulic Cylinder Barrel	A-0	1
7	0313-316-R	Rod for 3" x 16" Hydraulic Cylinder	A-0	1
8	0313-NCP1X63	Hydraulic Cylinder Pin 1" x 63mm		1
9	0313-NCP1X68DS	Hydraulic Cylinder Pin 1" x 68mm		1
10	0313-NP3	Hydraulic Cylinder Piston 3"	A-0	1
11	0313-NG15X3	Cylinder Gland 1.5" Rod x 3" Barrel	A-0	1
12	0313-NRC1X1 1-8	Hydraulic Cylinder Rod Clevis 1" Pin 1 1/8" Thread	A-0	1

Only **items in BOLD** are available as spare parts

KELLY

Part Number
0311-316SP

Description
3" Bore x 16" Stroke 1.5" Rod Side Port Hydraulic Cylinder

For Machines Built:

Revision
B-0

ITEM NO.	PART NUMBER	DESCRIPTION	Revision	QTY.
1	0313-324-BSTSP	3" x 24" STSP Hydraulic Cylinder Barrel		1
2	0313-324-R	Rod for 3" x 24" Hydraulic Cylinder	A-0	1
3	0313-NP3	Hydraulic Cylinder Piston 3"	A-0	1
4	0313-NRC1X1 1-8	Hydraulic Cylinder Rod Clevis 1" Pin 1 1/8" Thread	A-0	1
5	0312-N3-S	Nordon 3" Seal Kit-S	A-0	1
6	0223-NYL11-8	Nyloc Nut 1 1/8" UNF		1
7	0313-NG15X3	Cylinder Gland 1.5" Rod x 3" Barrel	A-0	1
8	0313-NCP1X63	Hydraulic Cylinder Pin 1" x 63mm		1
9	0313-NCP1X68DS	Hydraulic Cylinder Pin 1" x 68mm		1
10	0313-10I23M3	Retaining Lug	A-0	2
11	0211-820	M8 x 20 Class 8.8 ZP Bolt		2
12	0231-S8	Washer Spring M8		2
13	0313-STUBE1 1-2X1	Hydraulic Cylinder Stop Tube 1.5" ID x 1" (25mm) Long		1

Only items in **BOLD** are available as spare parts

Note: Replaces Cylinder 0311-324SP

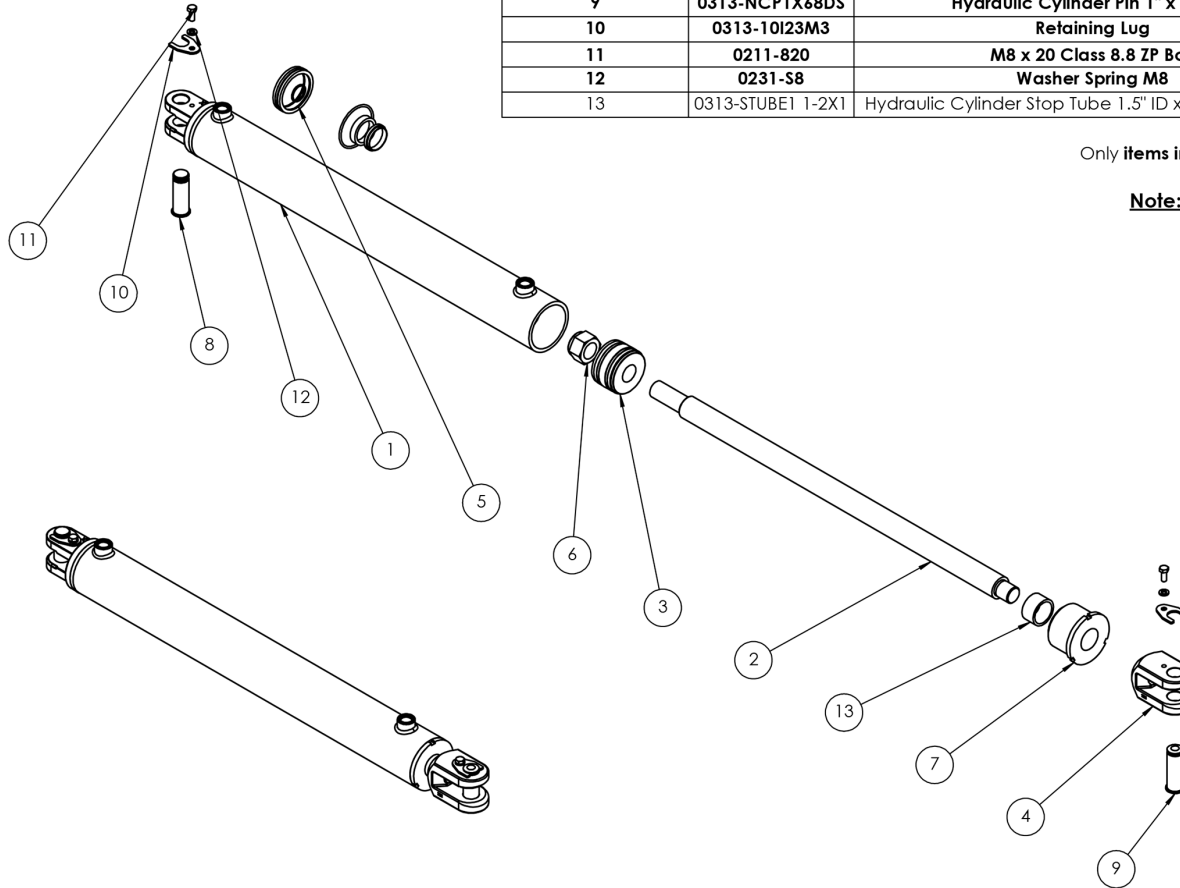

Part Number	Description	For Machines Built:	Revision
0311-324STSP	3" Bore x 24" Stroke 1.5" Rod Hydraulic Cylinder Stop Tube Side Port		B-0

ITEM NO.	PART NUMBER	Revision	DESCRIPTION	QTY.
1	0211-820		M8 x 20 Class 8.8 ZP Bolt	2
2	0223-NYL11-8		Nyloc Nut 1 1/8" UNF	1
3	0231-S8		Washer Spring M8	2
4	0312-N3-S	A-0	Nordon 3" Seal Kit-S	1
5	0313-10I23M3	A-0	Retaining Lug	2
6	0313-324-B	A-0	3" x 24" Hydraulic Cylinder Barrel	1
7	0313-324-R	A-0	Rod for 3" x 24" Hydraulic Cylinder	1
8	0313-NCP1X75	A-0	Hydraulic Cylinder Pin 1" x 75mm	2
9	0313-NG15X3	A-0	Cylinder Gland 1.5" Rod x 3" Barrel	1
10	0313-NP3	A-0	Hydraulic Cylinder Piston 3"	1
11	0313-NRC1X1 1-8	A-0	Hydraulic Cylinder Rod Clevis 1" Pin 1 1/8" Thread	1

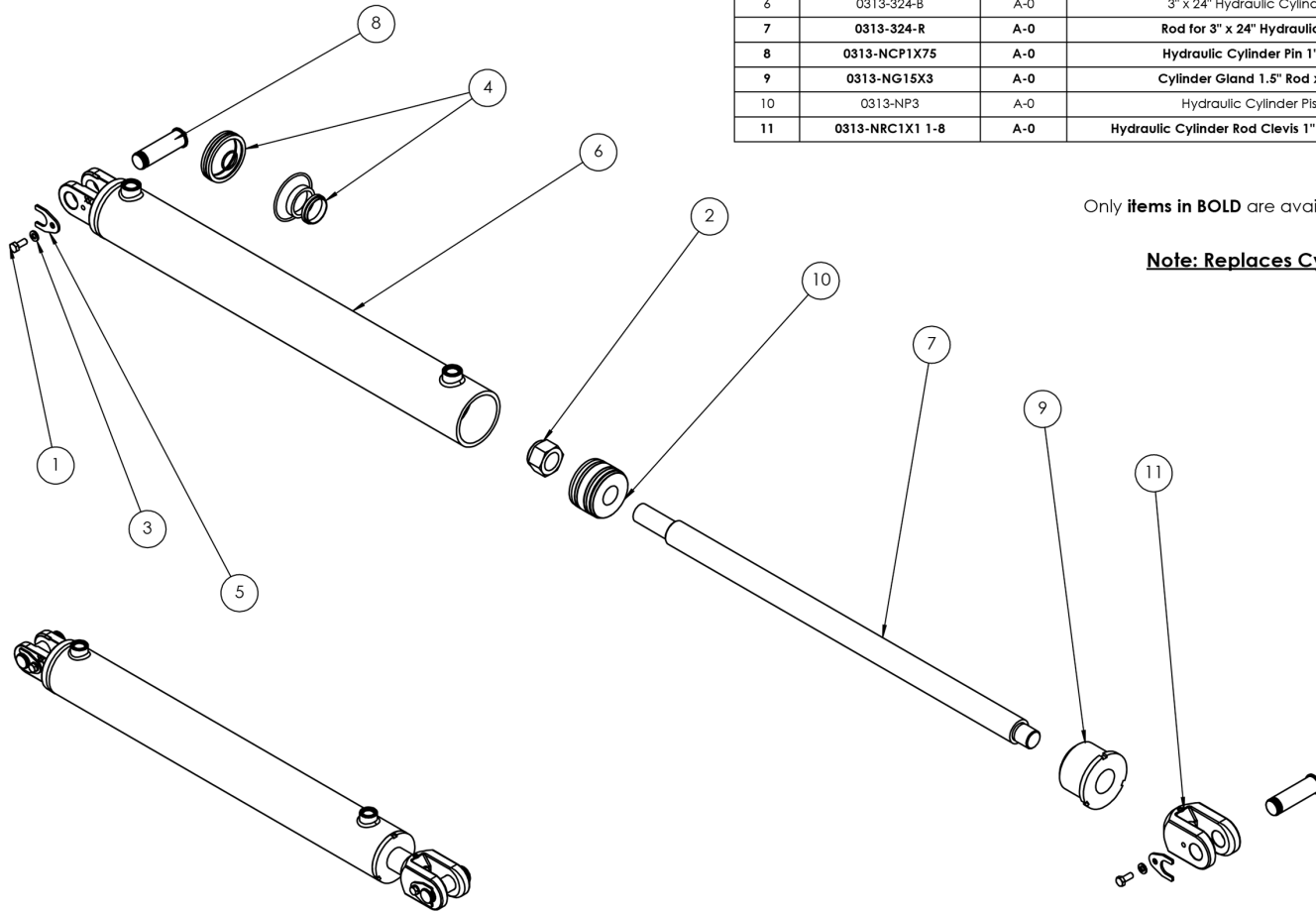

Only **items in BOLD** are available as spare parts

Note: Replaces Cylinder 0311-2957



Part Number 0311-324	Description 3" Bore x 24" Stroke 1.5" Rod Hydraulic Cylinder	For Machines Built:	Revision C-0
--------------------------------	---	---------------------	-----------------

ITEM NO.	PART NUMBER	DESCRIPTION	Revision	QTY.
1	0211-820	M8 x 20 Class 8.8 ZP Bolt		2
2	0223-NYL11-4	Nyloc Nut 1 1/4" UNF		1
3	0231-S8	Washer Spring M8		2
4	0312-N35-S	Nordon 3.5" Seal Kit-S	A-0	1
5	0313-10123M3	Retaining Lug	A-0	2
6	0313-3524SP-B	3.5" x 24" Side Port Hydraulic Cylinder Barrel	A-0	1
7	0313-3524SP-R	Rod For 3.5" x 24" Hydraulic Cylinder Barrel	A-0	1
8	0313-NCP1X75	Hydraulic Cylinder Pin 1" x 75mm	A-0	2
9	0313-NG175x35	Cylinder Gland 1.75" Rod x 3.5" Barrel	A-0	1
10	0313-NP35	Hydraulic Cylinder Piston 3 1/2"	A-0	1
11	0313-NRC1X1 1-2	Hydraulic Cylinder Rod Clevis 1" Pin 1 1/2" Thread	A-0	1

Only **items in BOLD** are available as spare parts

Note: Replaces Cylinder 0311-2958 / 0311-324

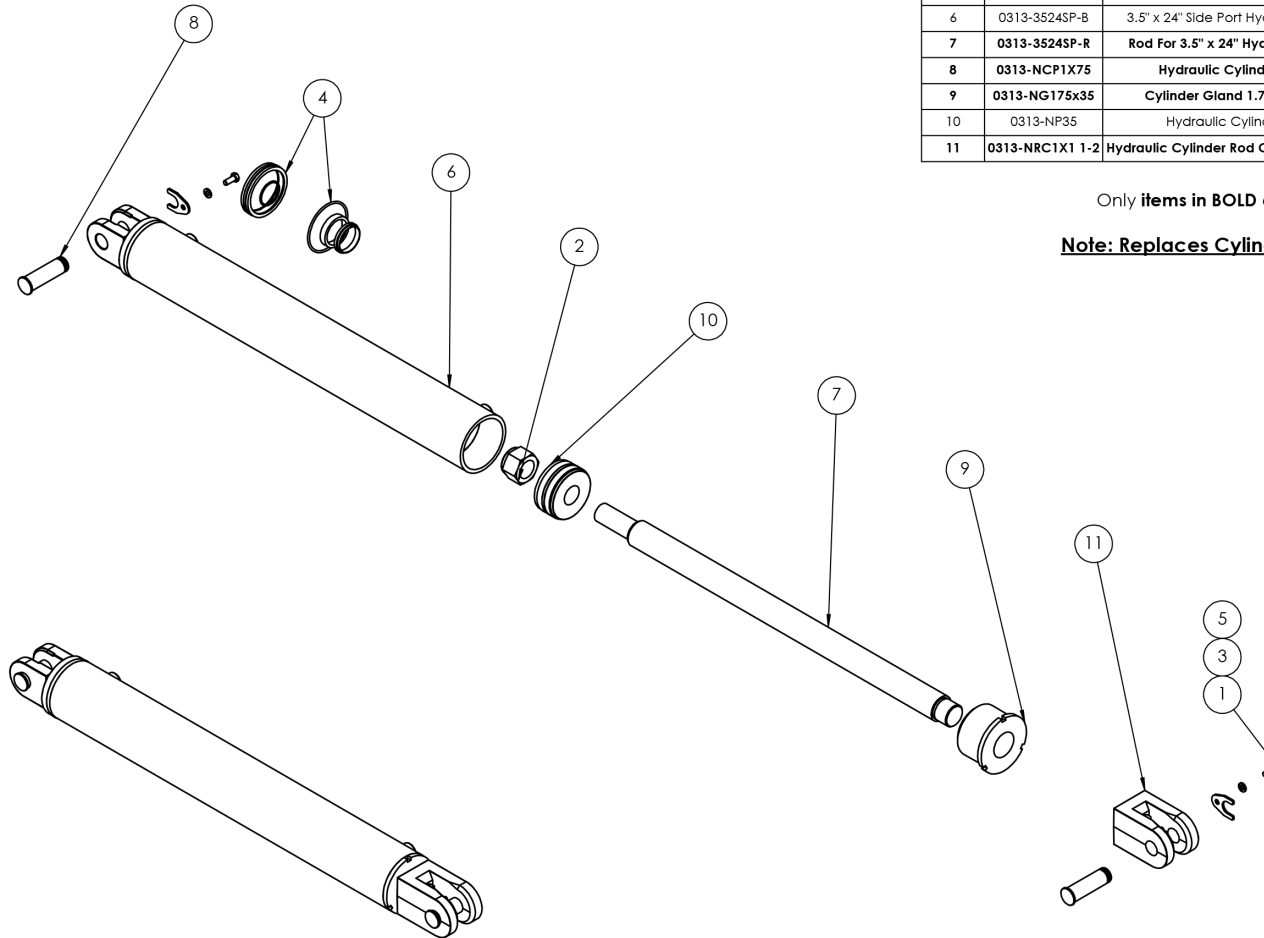

Part Number	Description	For Machines Built:	Revision
0311-3524SP	3.5" Bore x 24" Stroke 1.75" Rod Side Port Cylinder		D-0

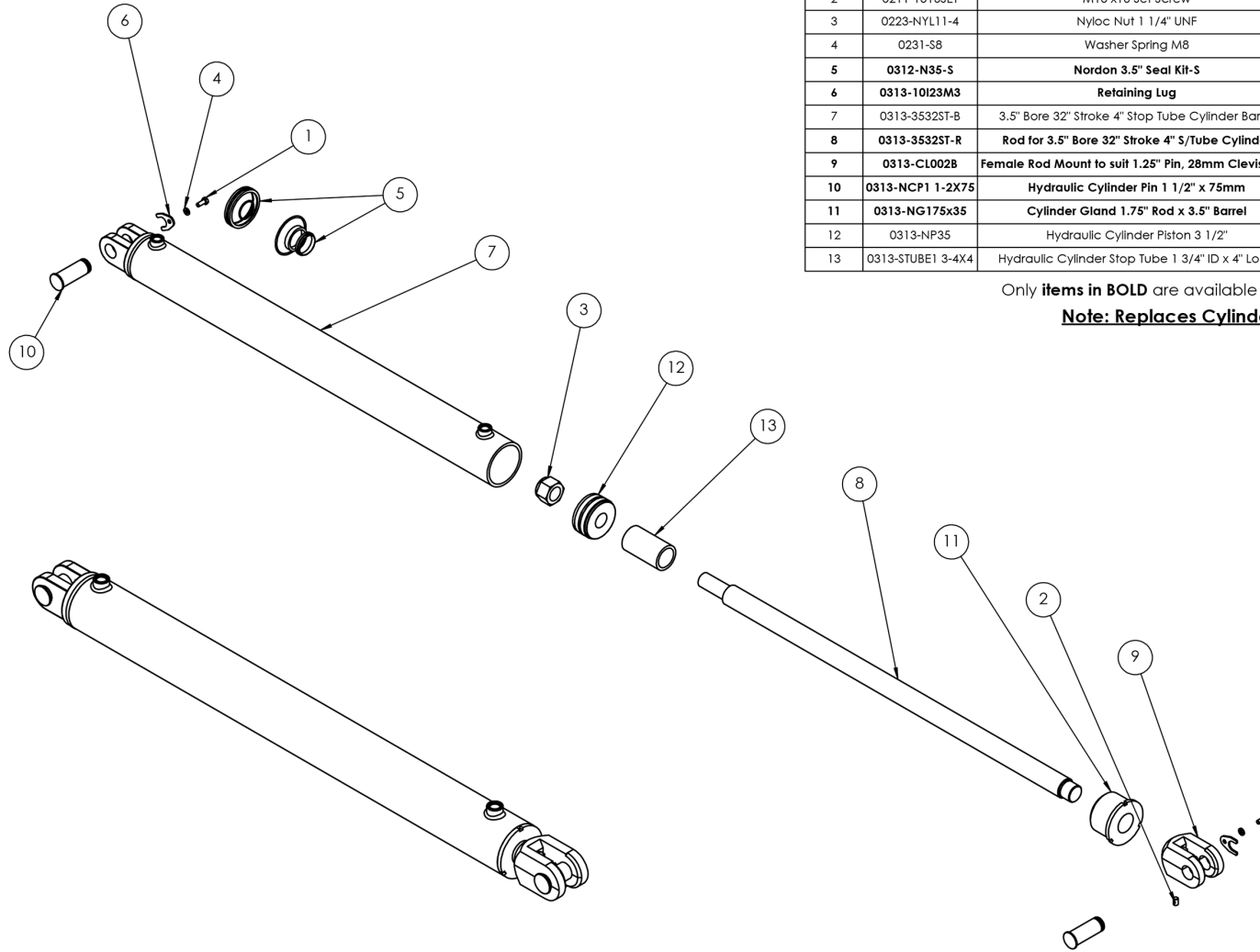

ITEM NO.	PART NUMBER	DESCRIPTION	Revision	QTY.
1	0211-820	M8 x 20 Class 8.8 ZP Bolt		2
2	0211-1016SET	M10 x16 Set Screw		1
3	0223-NYL11-4	Nyloc Nut 1 1/4" UNF		1
4	0231-S8	Washer Spring M8		2
5	0312-N35-S	Nordon 3.5" Seal Kit-S		1
6	0313-10I23M3	Retaining Lug	A-0	2
7	0313-3532ST-B	3.5" Bore 32" Stroke 4" Stop Tube Cylinder Barrel	A-1	1
8	0313-3532ST-R	Rod for 3.5" Bore 32" Stroke 4" S/Tube Cylinder	A-0	1
9	0313-CL002B	Female Rod Mount to suit 1.25" Pin, 28mm Clevis Gap		1
10	0313-NCP1 1-2X75	Hydraulic Cylinder Pin 1 1/2" x 75mm	A-0	2
11	0313-NG175x35	Cylinder Gland 1.75" Rod x 3.5" Barrel	A-0	1
12	0313-NP35	Hydraulic Cylinder Piston 3 1/2"	A-0	1
13	0313-STUBE1 3-4X4	Hydraulic Cylinder Stop Tube 1 3/4" ID x 4" Long	A-0	1

Only **items in BOLD** are available as spare parts

Note: Replaces Cylinder 0311-6896



Part Number	Description	For Machines Built:	Revision
0311-3532ST	3.5" Bore x 32" Stroke 1.75" Rod Cylinder with 4" Stop Tube		D-0

ITEM NO.	PART NUMBER	DESCRIPTION	Revision	QTY.	ITEM NO.	PART NUMBER	DESCRIPTION	Revision	QTY.
1	0211-820	M8 x 20 Class 8.8 ZP Bolt		2	11	0313-NCP1X68D5	Hydraulic Cylinder Pin 1" x 68mm		1
2	0223-NYL11-B	Nyloc Nut 1 1/8" UNF		1	12	0313-NG15X3	Cylinder Gland 1.5" Rod x 3" Barrel	A-0	1
3	0231-S8	Washer Spring M8		2	13	0313-NP3	Hydraulic Cylinder Piston 3"	A-0	1
4	0311-DSK	Depth Stop Kit	A-0	1	14	0313-NRC1X1 1-8 M	Rod Clevis 1" Pin 1 1/8" Thread (Machined for mount plate)	A-0	1
5	0312-N3-S	Nordon 3" Seal Kit-S	A-0	1	15	0313-SCVB	Single Counterbalance Valve Body	A-0	1
6	0313-10I23M3	Retaining Lug	A-0	2	16	0323-D12LLX	Tube Sealing Ring		2
7	0313-312EXT-B	3" Bore x 12" Stroke Extended Cylinder Barrel	A-0	1	17	0323-EGE12SRED	Flareless Swivel BSPP Male Adaptor		1
8	0313-312EXT-R	Rod for 3" Bore x 12" Stroke Extended Hydraulic Cylinder	A-0	1	18	0323-GE12SRED	24 Flareless BSPP Male Adaptor		1
9	0313-312EXT-TUBE	312/412EXT Retract Port Tube	A-0	1	19	0323-GE12SRED	24 Flareless BSPP Male Adaptor		2
10	0313-NCP1X63	Hydraulic Cylinder Pin 1" x 63mm		1	20	0341-CBCA-LHN	60 L/min Counterbalance valve		1
					21	0800-632	Depth Stop Mount	B-0	1

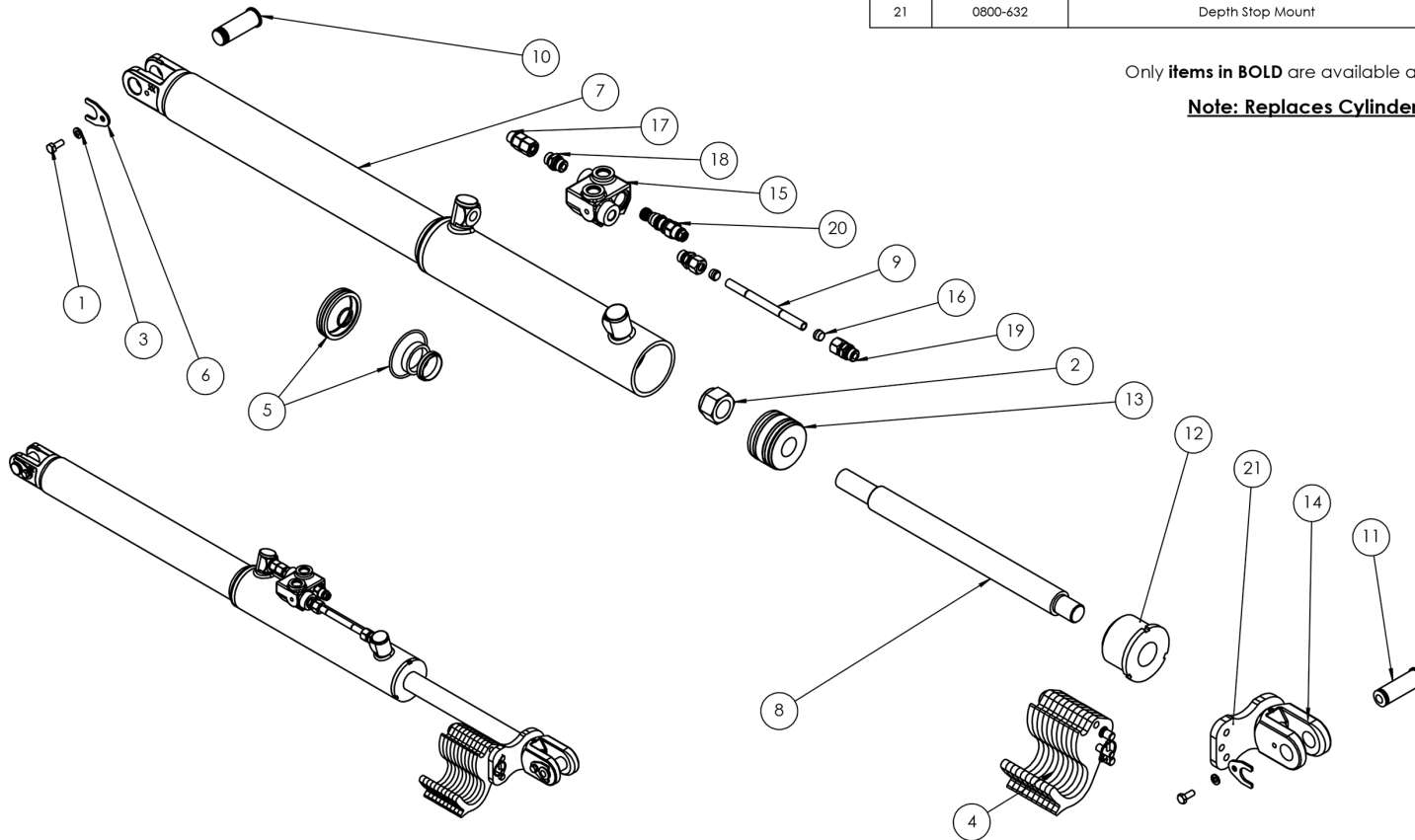

Only items in **BOLD** are available as spare parts

Note: Replaces Cylinder 0311-6002



Part Number	Description	For Machines Built:	Revision
0311-312EXT	3" Bore x 12" Stroke 1.5" Rod Extended Hydraulic Cylinder		H-0

ITEM NO.	PART NUMBER	DESCRIPTION	Revision	QTY.
1	0211-12110SHSCREW	Shoulder Screw M12 x 16 x 110	A	2
2	0231-SPRINGCUP	Compression Cup Washer		7
3	0266-Linch Pin 4x35	Round Linch Pin Ø4.5mm x 35mm S3545		1
4	0800-620	Locking Depth Stop Plate for Cylinder	B-0	10
5	0801-P10-135	Cylinder Depth Stop Lock Pin	A-0	1

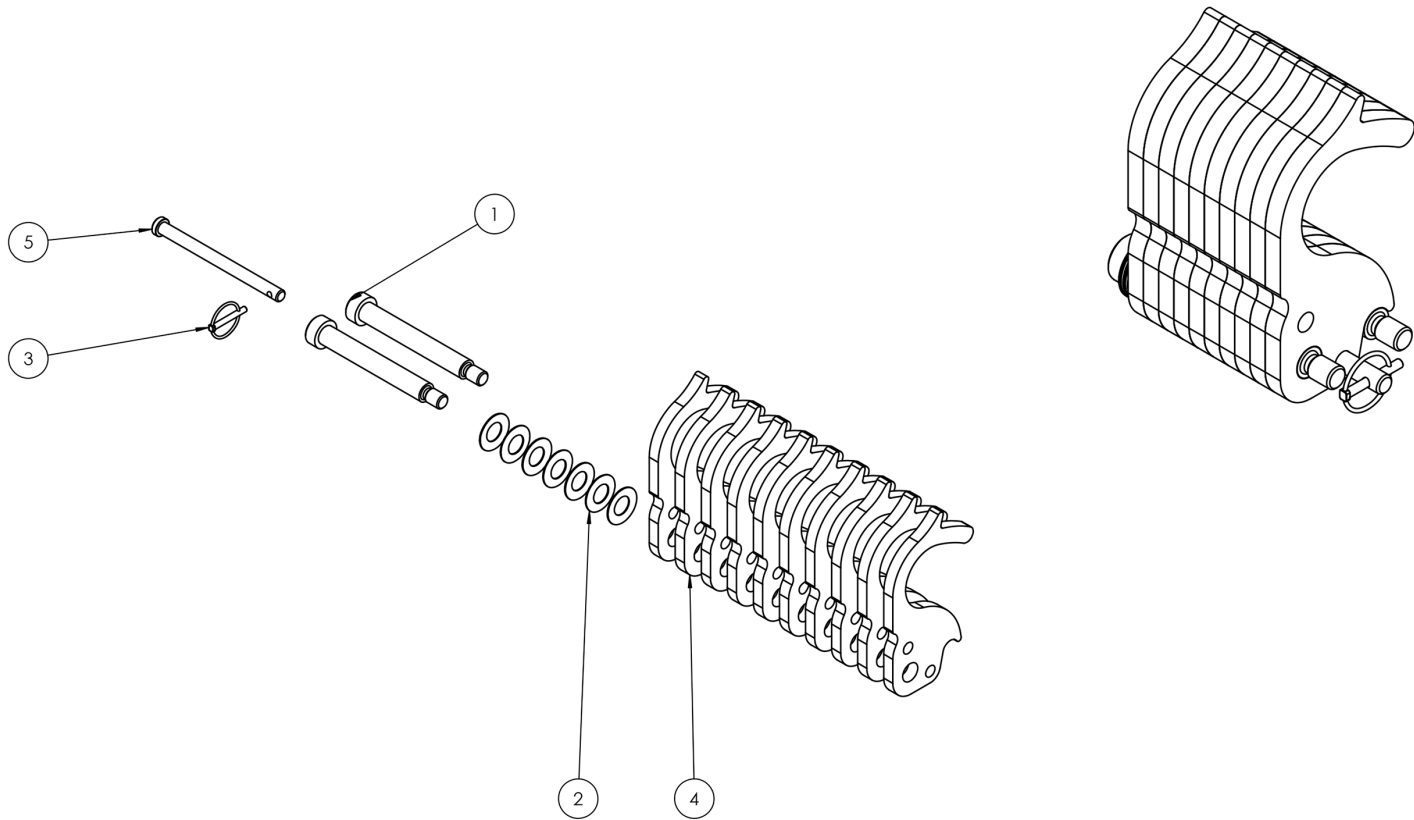

Part Number 0311-DSK	Description Depth Stop Kit	For Machines Built:	Revision A-0
--------------------------------	-------------------------------	---------------------	-----------------

ITEM NO.	PART NUMBER	Revision	DESCRIPTION	QTY.
1	0211-820		M8 x 20 Class 8.8 ZP Bolt	2
2	0211-12110SHSCREW	A	Shoulder Screw M12 x 16 x 110	2
3	0223-NYL11-2		Nyloc Nut 1 1/2" UNF	1
4	0231-S8		Washer Spring M8	2
5	0231-SPRINGCUP		Compression Cup Washer	7
6	0312-N4-S	A-0	Nordon 4" Seal Kit-S	1
7	0313-10123M3	A-0	Retaining Lug	2
8	0313-412EXT-B	B-0	4" Bore x 12" Stroke Extended Cylinder Barrel	1
9	0313-412EXT-HAMP	A-0	0313-412EXT Height Adjustor Mount Plate	1
10	0313-412EXT-R	B-0	Rod For 4" x 12" Extended Hydraulic Cylinder	1

ITEM NO.	PART NUMBER	Revision	DESCRIPTION	QTY.
11	0313-412EXT-TUBE	A-0	0311-412EXT Retract Port Tube	1
12	0313-CL002		Female Rod Mount to suit 1.25" Pin, 28mm Clevis Gap	1
13	0313-NCP1X63		Hydraulic Cylinder Pin 1" x 63mm	1
14	0313-NCP1X71		Hydraulic Cylinder Pin 1" x 71mm	1
15	0313-NG175X4	A-0	Cylinder Gland 1.75" Rod x 4" Barrel	1
16	0313-NP4	A-0	Hydraulic Cylinder Piston 4"	1
17	0313-SCVB	A-0	Single Counterbalance Valve Body	1
18	0323-D12LLX		Tube Sealing Ring	2
19	0323-EGE12SRED		Flareless Swivel BSPP Male Adaptor	1
20	0323-GE12SRED		24 Flareless BSPP Male Adaptor	1
21	0323-GE12SRED		24 Flareless BSPP Male Adaptor	2
22	0341-CBCA-LHN		60 L/min Counterbalance valve	1
23	0800-278		Cylinder Depth Stop Plate	10

Only items in **BOLD** are available as spare parts

Note: Replaces Cylinder 0311-6357

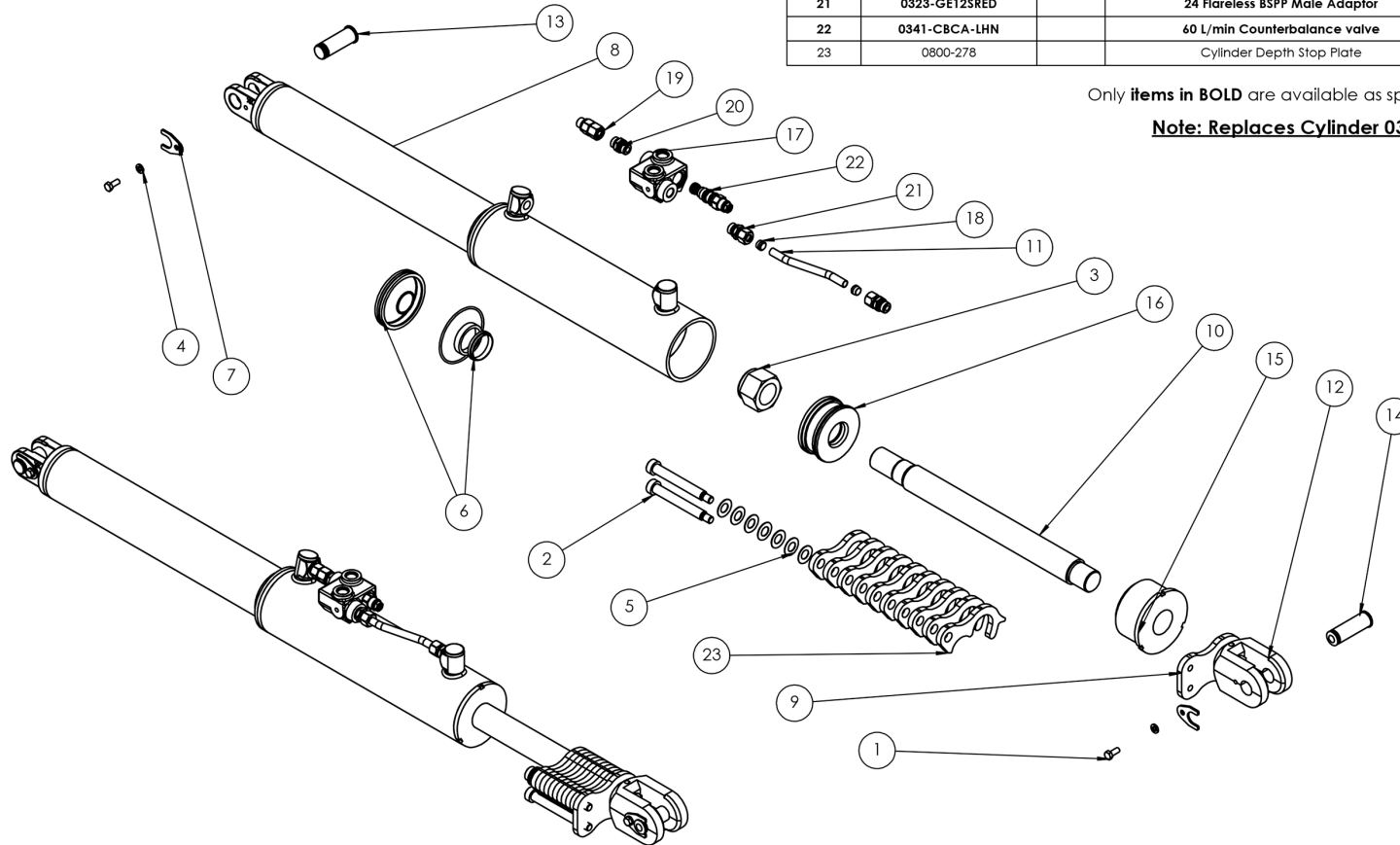

Part Number	Description	For Machines Built:	Revision
0311-412EXT	4" Bore 12" Stroke 1.75" Rod Extended Hydraulic Cylinder		F-0

ITEM NO.	PART NUMBER	DESCRIPTION	Revision	QTY.
1	0211-820	M8 x 20 Class 8.8 ZP Bolt		2
2	0223-NYL11-2	Nyloc Nut 1 1/2" UNF		1
3	0231-S8	Washer Spring M8		2
4	0311-DSK	Depth Stop Kit	A-0	1
5	0312-N4-2	Nordon 4" Bore 2" Rod Seal Kit		1
6	0313-10I23M3	Retaining Lug	A-0	2
7	0313-412EXT-B	4" Bore x 12" Stroke Extended Cylinder Barrel	B-0	1
8	0313-412EXT-R2	2" Rod For 4" x 12" Extended Hydraulic Cylinder	A-0	1
9	0313-412EXT-TUBE	0311-412EXT Retract Port Tube	A-0	1
10	0313-GN4020	Cylinder Gland 2" Rod x 4" Barrel		1

ITEM NO.	PART NUMBER	DESCRIPTION	Revision	QTY.
11	0313-NCP1X63	Hydraulic Cylinder Pin 1" x 63mm		1
12	0313-NCP1X71	Hydraulic Cylinder Pin 1" x 71mm		1
13	0313-NP4	Hydraulic Cylinder Piston 4"	A-0	1
14	0313-CL002	Female Rod Mount to suit 1.25" Pin, 28mm Clevis Gap		1
15	0313-SCVB	Single Counterbalance Valve Body	A-0	1
16	0323-D12LLX	Tube Sealing Ring		2
17	0323-EGE12SRED	Flareless Swivel BSPP Male Adaptor		1
18	0323-GE12SRED	24 Flareless BSPP Male Adaptor		3
19	0341-CBCA-LHN	60 L/min Counterbalance valve		1
20	0800-632	Depth Stop Mount	A-0	1

Only items in **BOLD** are available as spare parts

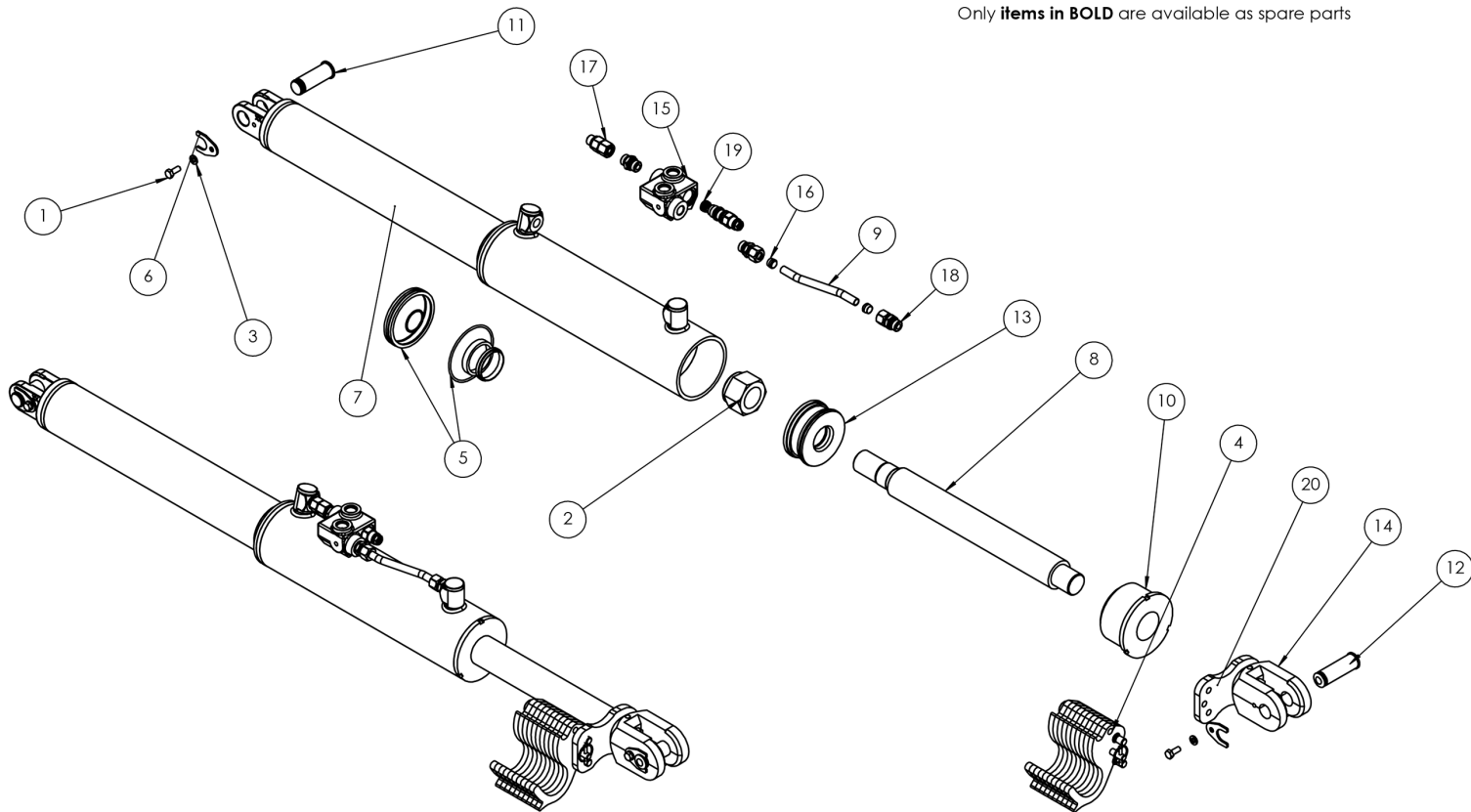

Part Number	Description	Revision
0311-412EXT-2	4" Bore 12" Stroke 2" Rod Extended Hydraulic Cylinder	D-0

ITEM NO.	PART NUMBER	DESCRIPTION	Revision	QTY.
1	0211-820	M8 x 20 Class 8.8 ZP Bolt		2
2	0211-1016SET	M10 x16 Set Screw		1
3	0223-NYL11-2	Nyloc Nut 1 1/2" UNF		1
4	0231-S8	Washer Spring M8		2
5	0312-N4-S	Nardon 4" Seal Kit-S	A-0	1
6	0313-10123M3	Retaining Lug	A-0	2
7	0313-416-R	Rod for 4" Bore x 16" Stroke Hydraulic Cylinder	A-0	1
8	0313-416SP-B	4" Bore x 16" Side Port Stroke Hydraulic Cylinder Barrel	A-0	1
9	0313-CL002B	Female Rod Mount to suit 1.25" Pin, 28mm Clevis Gap		1
10	0313-NCP1 1-2X75	Hydraulic Cylinder Pin 1 1/2" x 75mm	A-0	2
11	0313-NG175X4	Cylinder Gland 1.75" Rod x 4" Barrel	A-0	1
12	0313-NP4	Hydraulic Cylinder Piston 4"	A-0	1

Only items in **BOLD** are available as spare parts

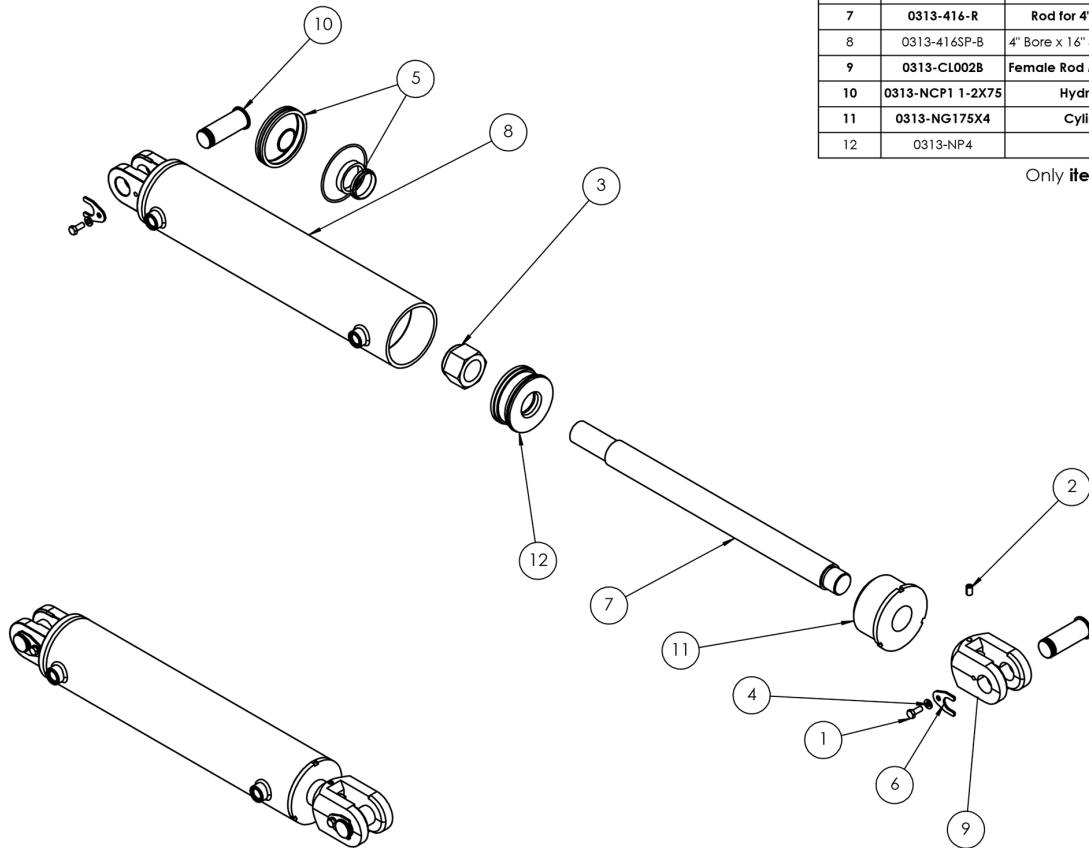

Part Number	Description	For Machines Built:	Revision
0311-416SP	4" Bore 16" Stroke 1.75" Rod Hydraulic Cylinder		B-0

ITEM NO.	PART NUMBER	DESCRIPTION	Revision	QTY.
1	0211-1016SET	M10 x16 Set Screw		1
2	0211-820	M8 x 20 Class 8.8 ZP Bolt		2
3	0223-NYL11-2	Nyloc Nut 1 1/2" UNF		1
4	0231-S8	Washer Spring M8		2
5	0312-N4-S	Nordon 4" Seal Kit-S	A-0	1
6	0313-10123M3	Retaining Lug	A-0	2
7	0313-424-B	4" Bore x 24" Stroke Hydraulic Cylinder Barrel		1
8	0313-424-R	Rod for 4" Bore x 24" Stroke Hydraulic Cylinder	A-0	1
9	0313-CL002B	Female Rod Mount to suit 1.25" Pin, 28mm Clevis Gap		1
10	0313-GN4017-S	4.0" Steel Gland - 1.75" Shaft		1
11	0313-NCP1 1-2X75	Hydraulic Cylinder Pin 1 1/2" x 75mm	A-0	2
12	0313-NP4	Hydraulic Cylinder Piston 4"	A-0	1

Only **items in BOLD** are available as spare parts

Note: Replaces Cylinder 0311-3786

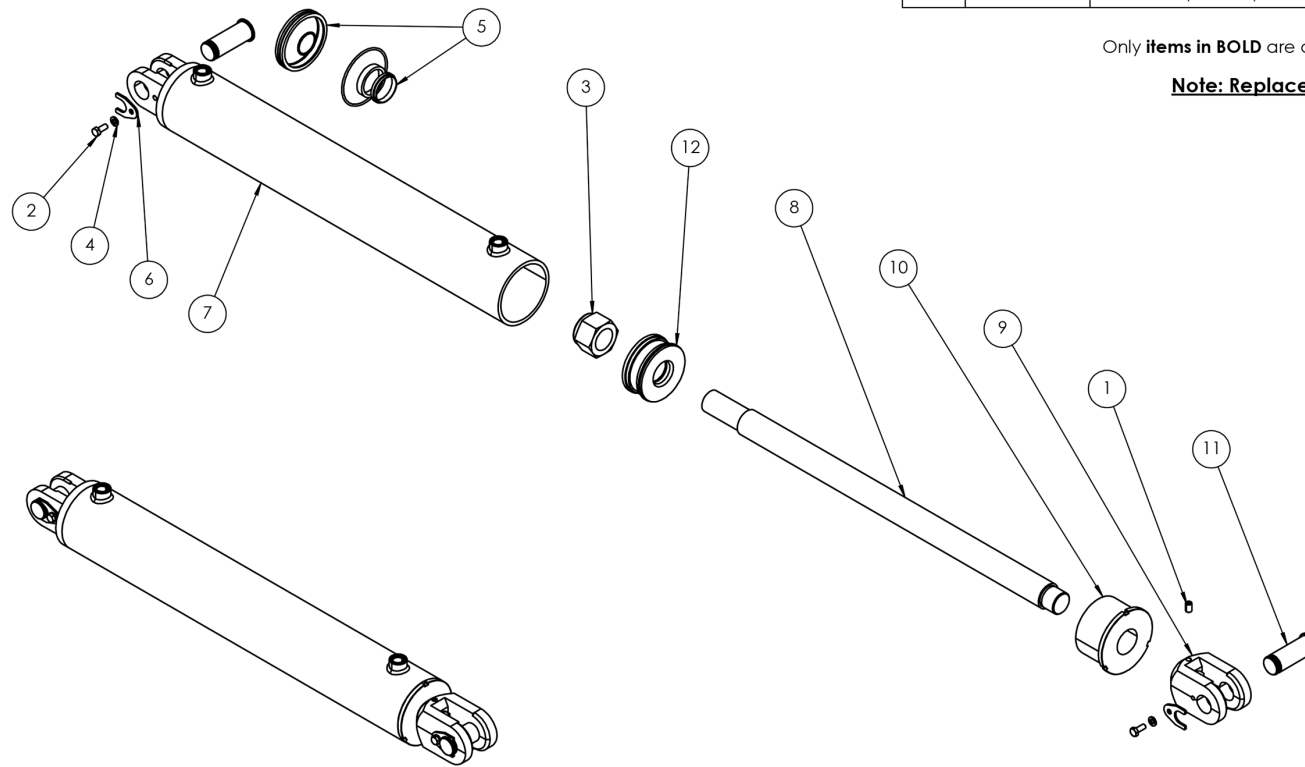

Part Number	Description	For Machines Built:	Revision
0311-424	4" Bore 24" Stroke 1.75" Rod Hydraulic Cylinder		D-0

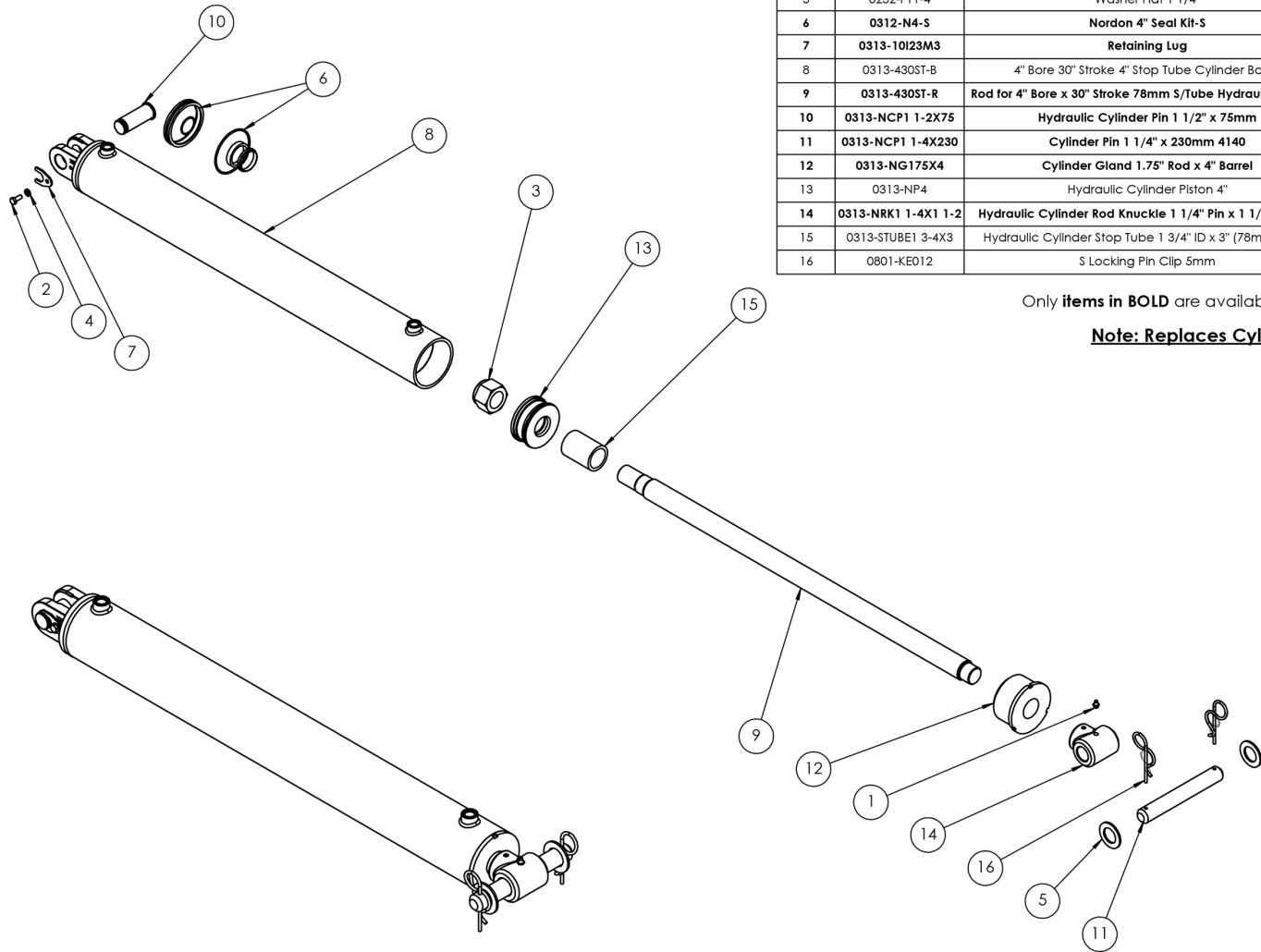

ITEM NO.	PART NUMBER	DESCRIPTION	Revision	QTY.
1	0181-GN1-8	Grease Nipple 1/8" BSP	A	1
2	0211-820	M8 x 20 Class 8.8 ZP Bolt		1
3	0223-NYL11-2	Nyloc Nut 1 1/2" UNF		1
4	0231-S8	Washer Spring M8		1
5	0232-F11-4	Washer Flat 1 1/4"		2
6	0312-N4-S	Nordon 4" Seal Kit-S	A-0	1
7	0313-10I23M3	Retaining Lug	A-0	1
8	0313-430ST-B	4" Bore 30" Stroke 4" Stop Tube Cylinder Barrel	A-0	1
9	0313-430ST-R	Rod for 4" Bore x 30" Stroke 78mm S/Tube Hydraulic Cylinder	A-0	1
10	0313-NCP1 1-2X75	Hydraulic Cylinder Pin 1 1/2" x 75mm	A-0	1
11	0313-NCP1 1-4X230	Cylinder Pin 1 1/4" x 230mm 4140	A-0	1
12	0313-NG175X4	Cylinder Gland 1.75" Rod x 4" Barrel	A-0	1
13	0313-NP4	Hydraulic Cylinder Piston 4"	A-0	1
14	0313-NRK1 1-4X1 1-2	Hydraulic Cylinder Rod Knuckle 1 1/4" Pin x 1 1/2" Thread	A-0	1
15	0313-STUBE1 3-4X3	Hydraulic Cylinder Stop Tube 1 3/4" ID x 3" (78mm) Long	A-0	1
16	0801-KE012	S Locking Pin Clip 5mm	A	2

Only items in **BOLD** are available as spare parts

Note: Replaces Cylinder 0311-4781



Part Number	Description	For Machines Built:	Revision
0311-430ST	4" Bore x 30" Stroke 1.75" Rod Cylinder with 3" Stop Tube		D-0

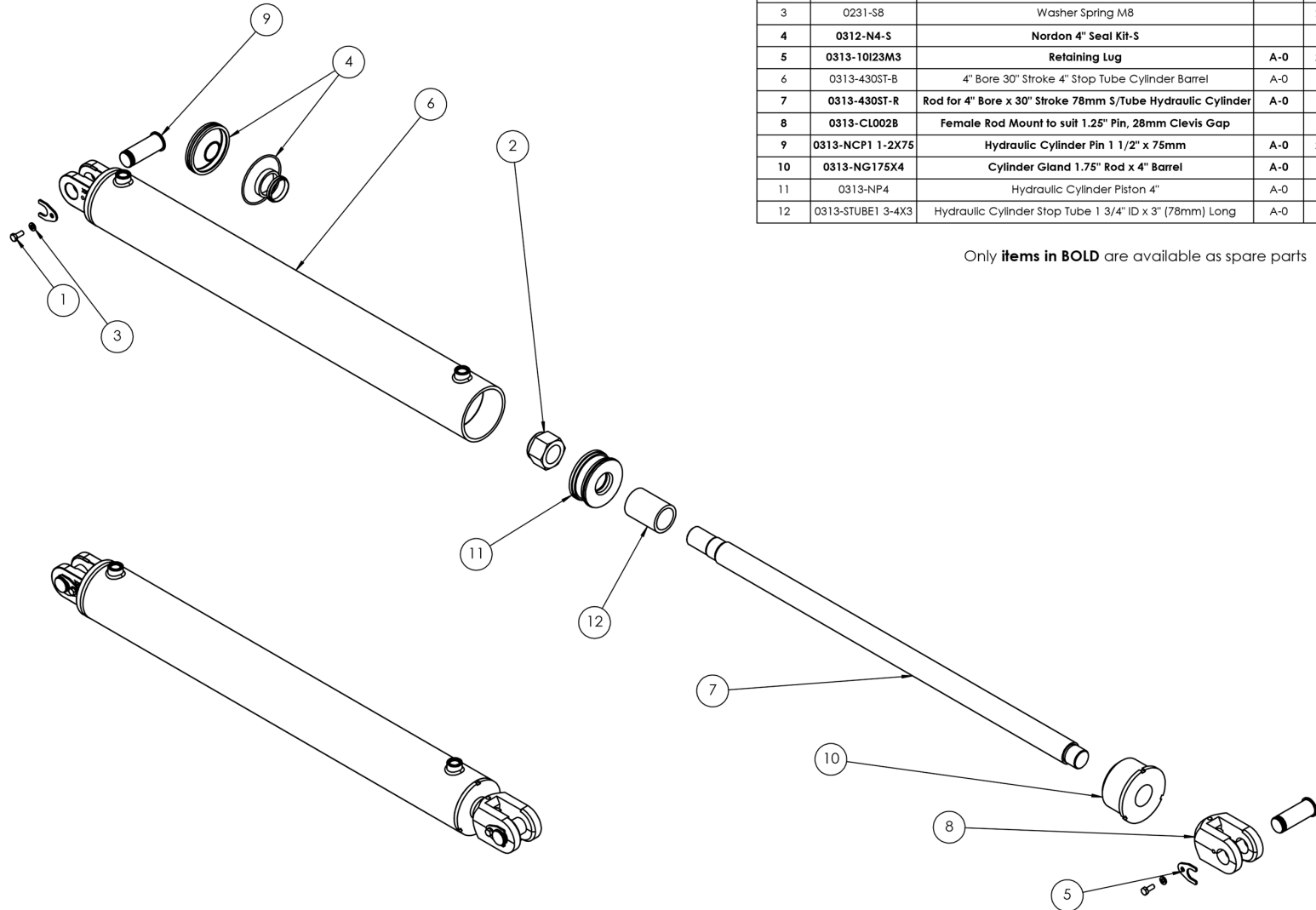

ITEM NO.	PART NUMBER	DESCRIPTION	Revision	QTY.
1	0211-820	M8 x 20 Class 8.8 ZP Bolt		2
2	0223-NYL11-2	Nyloc Nut 1 1/2" UNF		1
3	0231-S8	Washer Spring M8		2
4	0312-N4-S	Nordon 4" Seal Kit-S		1
5	0313-10I23M3	Retaining Lug	A-0	2
6	0313-430ST-B	4" Bore 30" Stroke 4" Stop Tube Cylinder Barrel	A-0	1
7	0313-430ST-R	Rod for 4" Bore x 30" Stroke 78mm S/Tube Hydraulic Cylinder	A-0	1
8	0313-CL002B	Female Rod Mount to suit 1.25" Pin, 28mm Clevis Gap		1
9	0313-NCP1 1-2X75	Hydraulic Cylinder Pin 1 1/2" x 75mm	A-0	2
10	0313-NG175X4	Cylinder Gland 1.75" Rod x 4" Barrel	A-0	1
11	0313-NP4	Hydraulic Cylinder Piston 4"	A-0	1
12	0313-STUBE1 3-4X3	Hydraulic Cylinder Stop Tube 1 3/4" ID x 3" (78mm) Long	A-0	1

Only **items in BOLD** are available as spare parts



Part Number	Description	For Machines Built:	Revision
0311-430ST-C2	4" Bore 30" Stroke 3" S/Tube 1.75" Rod Hydraulic Cylinder with Stop Tube & Clevis		C-0

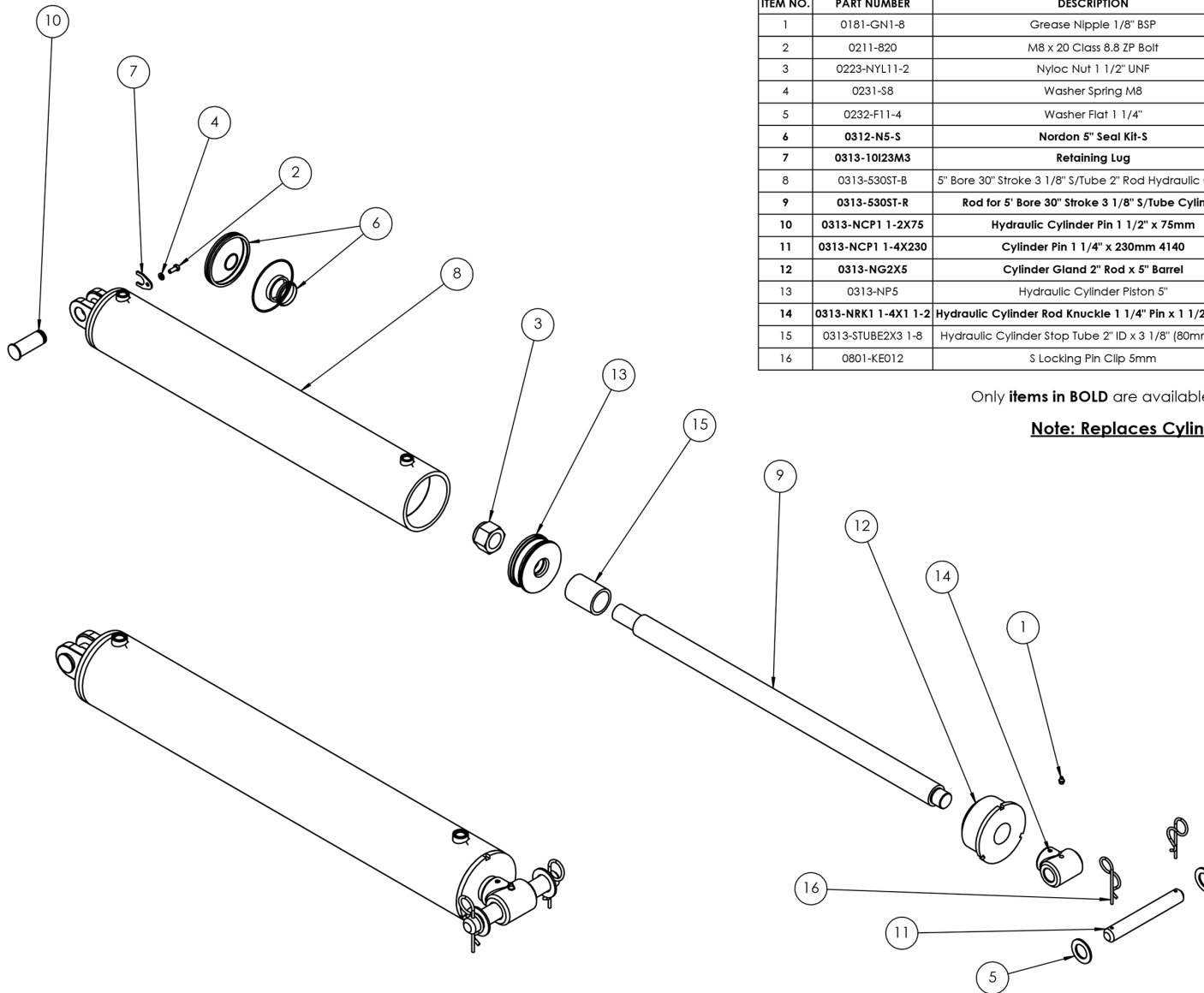

ITEM NO.	PART NUMBER	DESCRIPTION	Revision	QTY.
1	0181-GN1-8	Grease Nipple 1/8" BSP	A	1
2	0211-820	M8 x 20 Class 8.8 ZP Bolt		1
3	0223-NYL11-2	Nyloc Nut 1 1/2" UNF		1
4	0231-S8	Washer Spring M8		1
5	0232-F11-4	Washer Flat 1 1/4"		2
6	0312-N5-S	Nordon 5" Seal Kit-S	A-0	1
7	0313-10I23M3	Retaining Lug	A-0	1
8	0313-530ST-B	5" Bore 30" Stroke 3 1/8" S/Tube 2" Rod Hydraulic Cylinder	A-0	1
9	0313-530ST-R	Rod for 5" Bore 30" Stroke 3 1/8" S/Tube Cylinder	A-0	1
10	0313-NCP1 1-2X75	Hydraulic Cylinder Pin 1 1/2" x 75mm	A-0	1
11	0313-NCP1 1-4X230	Cylinder Pin 1 1/4" x 230mm 4140	A-0	1
12	0313-NG2X5	Cylinder Gland 2" Rod x 5" Barrel	A-0	1
13	0313-NP5	Hydraulic Cylinder Piston 5"	A-0	1
14	0313-NRK1 1-4X1 1-2	Hydraulic Cylinder Rod Knuckle 1 1/4" Pin x 1 1/2" Thread	A-0	1
15	0313-STUBE2X3 1-8	Hydraulic Cylinder Stop Tube 2" ID x 3 1/8" (80mm) Long	A-0	1
16	0801-KE012	S Locking Pin Clip 5mm	A	2

Only items in **BOLD** are available as spare parts

Note: Replaces Cylinder 0311-5040



Part Number 0311-530ST	Description 5" Bore x 30" Stroke 2" Rod Cylinder with 3-1/8" Stop Tube	For Machines Built:	Revision C-0
----------------------------------	---	---------------------	-----------------

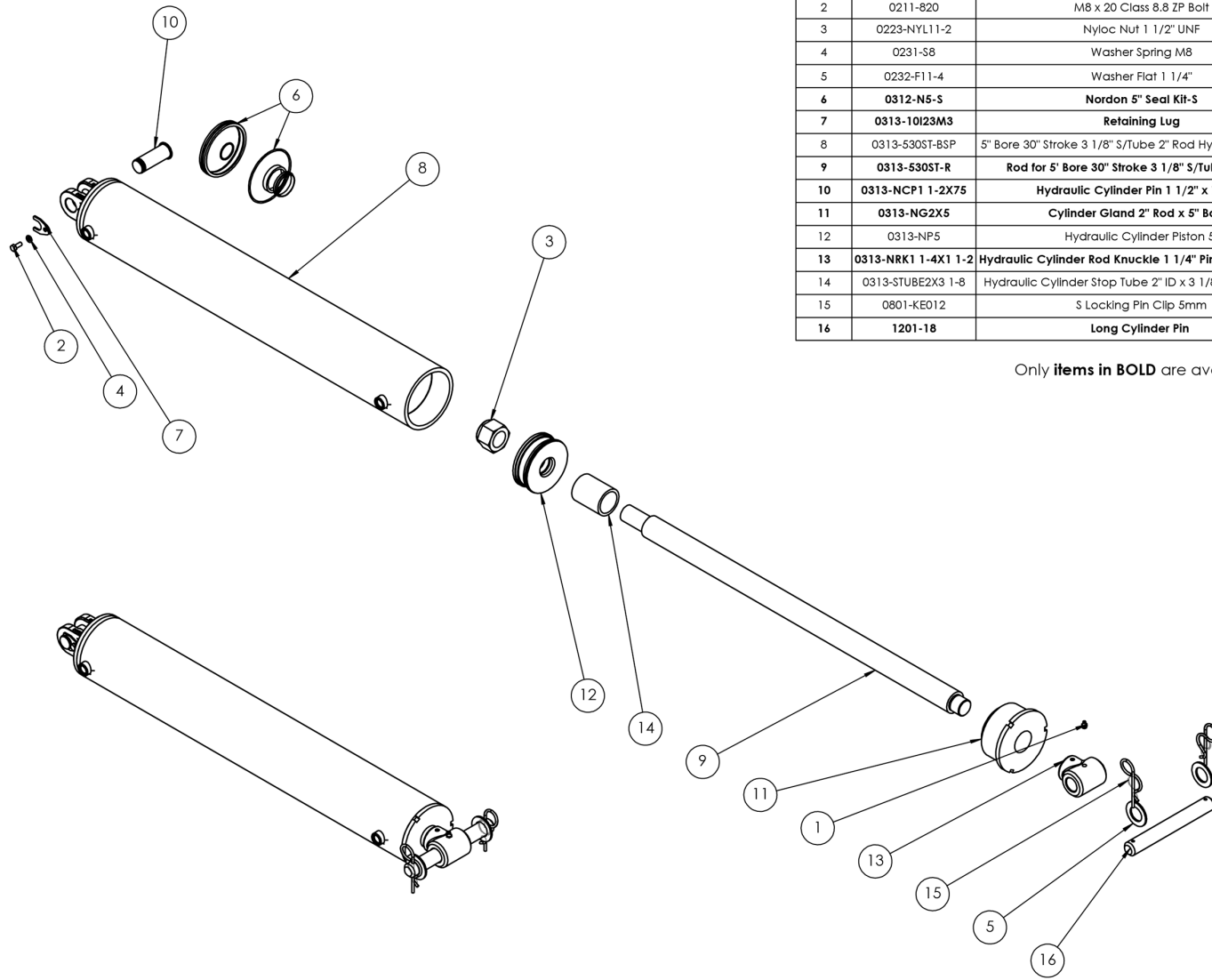

ITEM NO.	PART NUMBER	DESCRIPTION	Revision	QTY.
1	0181-GN1-8	Grease Nipple 1/8" BSP	A	1
2	0211-820	M8 x 20 Class 8.8 ZP Bolt		1
3	0223-NYL11-2	Nyloc Nut 1 1/2" UNF		1
4	0231-S8	Washer Spring M8		1
5	0232-F11-4	Washer Flat 1 1/4"		2
6	0312-N5-S	Nordon 5" Seal Kit-S	A-0	1
7	0313-10I23M3	Retaining Lug	A-0	1
8	0313-530ST-BSP	5" Bore 30" Stroke 3 1/8" S/Tube 2" Rod Hydraulic Cylinder		1
9	0313-530ST-R	Rod for 5" Bore 30" Stroke 3 1/8" S/Tube Cylinder	A-0	1
10	0313-NCP1 1-2X75	Hydraulic Cylinder Pin 1 1/2" x 75mm	A-0	1
11	0313-NG2X5	Cylinder Gland 2" Rod x 5" Barrel	A-0	1
12	0313-NP5	Hydraulic Cylinder Piston 5"	A-0	1
13	0313-NRK1 1-4X1 1-2	Hydraulic Cylinder Rod Knuckle 1 1/4" Pin x 1 1/2" Thread	A-0	1
14	0313-STUBE2X3 1-8	Hydraulic Cylinder Stop Tube 2" ID x 3 1/8" (80mm) Long	A-0	1
15	0801-KE012	S Locking Pin Clip 5mm	A	2
16	1201-18	Long Cylinder Pin	A	1

Only items in **BOLD** are available as spare parts



Part Number	Description	For Machines Built:	Revision
0311-530STSP	5" Bore 30" Stroke 3 1/8" S/Tube 2" Rod Hydraulic Cylinder		B-0

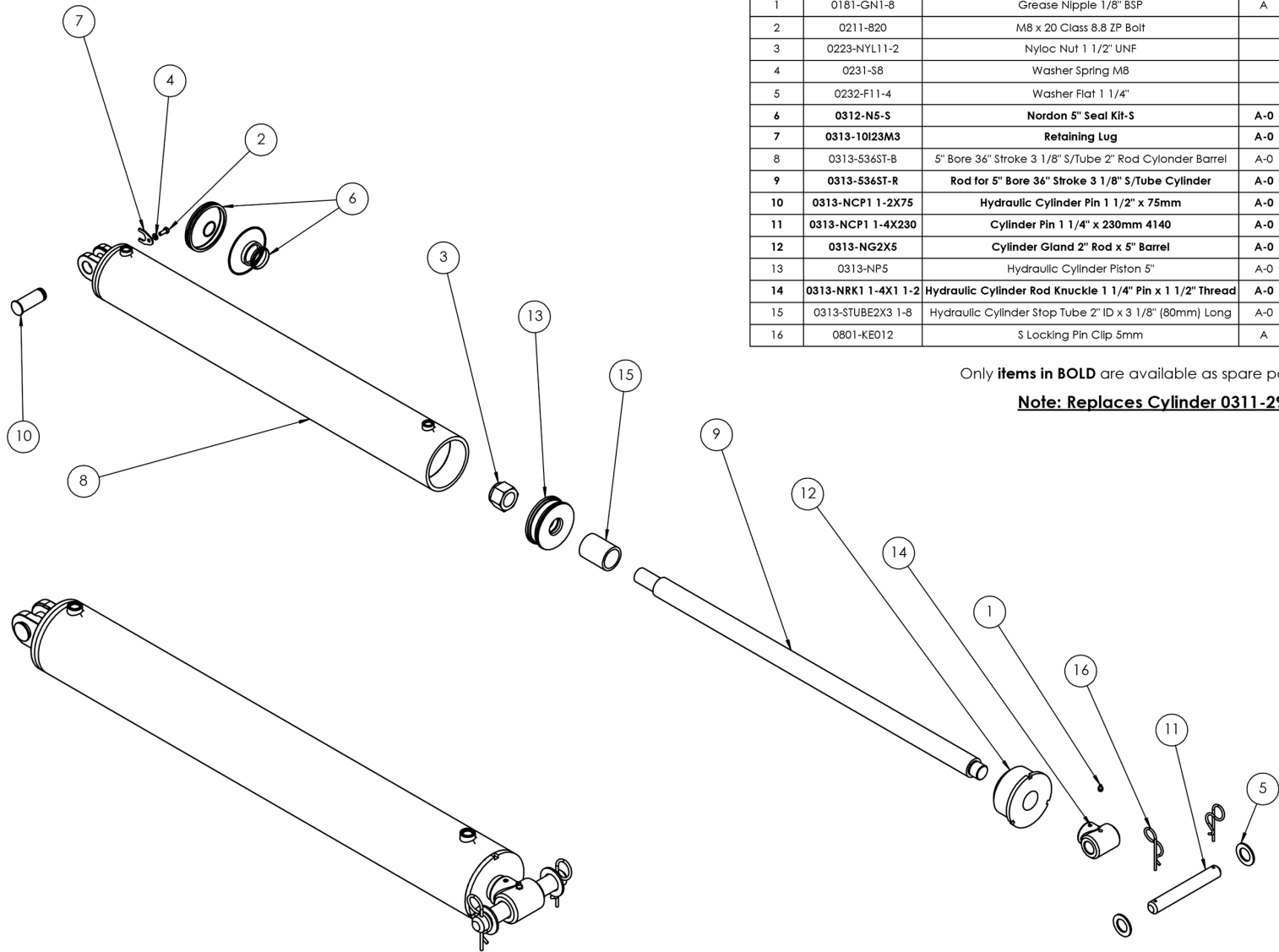

ITEM NO.	PART NUMBER	DESCRIPTION	Revision	QTY.
1	0181-GN1-8	Grease Nipple 1/8" BSP	A	1
2	0211-820	M8 x 20 Class 8.8 ZP Bolt		1
3	0223-NYL11-2	Nyloc Nut 1 1/2" UNF		1
4	0231-S8	Washer Spring M8		1
5	0232-F11-4	Washer Flat 1 1/4"		2
6	0312-N5-S	Nordon 5" Seal Kit-S	A-0	1
7	0313-10I23M3	Retaining Lug	A-0	1
8	0313-536ST-B	5" Bore 36" Stroke 3 1/8" S/Tube 2" Rod Cylinder Barrel	A-0	1
9	0313-536ST-R	Rod for 5" Bore 36" Stroke 3 1/8" S/Tube Cylinder	A-0	1
10	0313-NCP1 1-2X75	Hydraulic Cylinder Pin 1 1/2" x 75mm	A-0	1
11	0313-NCP1 1-4X230	Cylinder Pin 1 1/4" x 230mm 4140	A-0	1
12	0313-NG2X5	Cylinder Gland 2" Rod x 5" Barrel	A-0	1
13	0313-NP5	Hydraulic Cylinder Piston 5"	A-0	1
14	0313-NRK1 1-4X1 1-2	Hydraulic Cylinder Rod Knuckle 1 1/4" Pin x 1 1/2" Thread	A-0	1
15	0313-STUBE2X3 1-8	Hydraulic Cylinder Stop Tube 2" ID x 3 1/8" (80mm) Long	A-0	1
16	0801-KE012	S Locking Pin Clip 5mm	A	2

Only items in BOLD are available as spare parts

Note: Replaces Cylinder 0311-2956



Part Number	Description	For Machines Built:	Revision
0311-536ST	5" Bore x 36" Stroke 2" Rod Cylinder with 3" Stop Tube		D-0

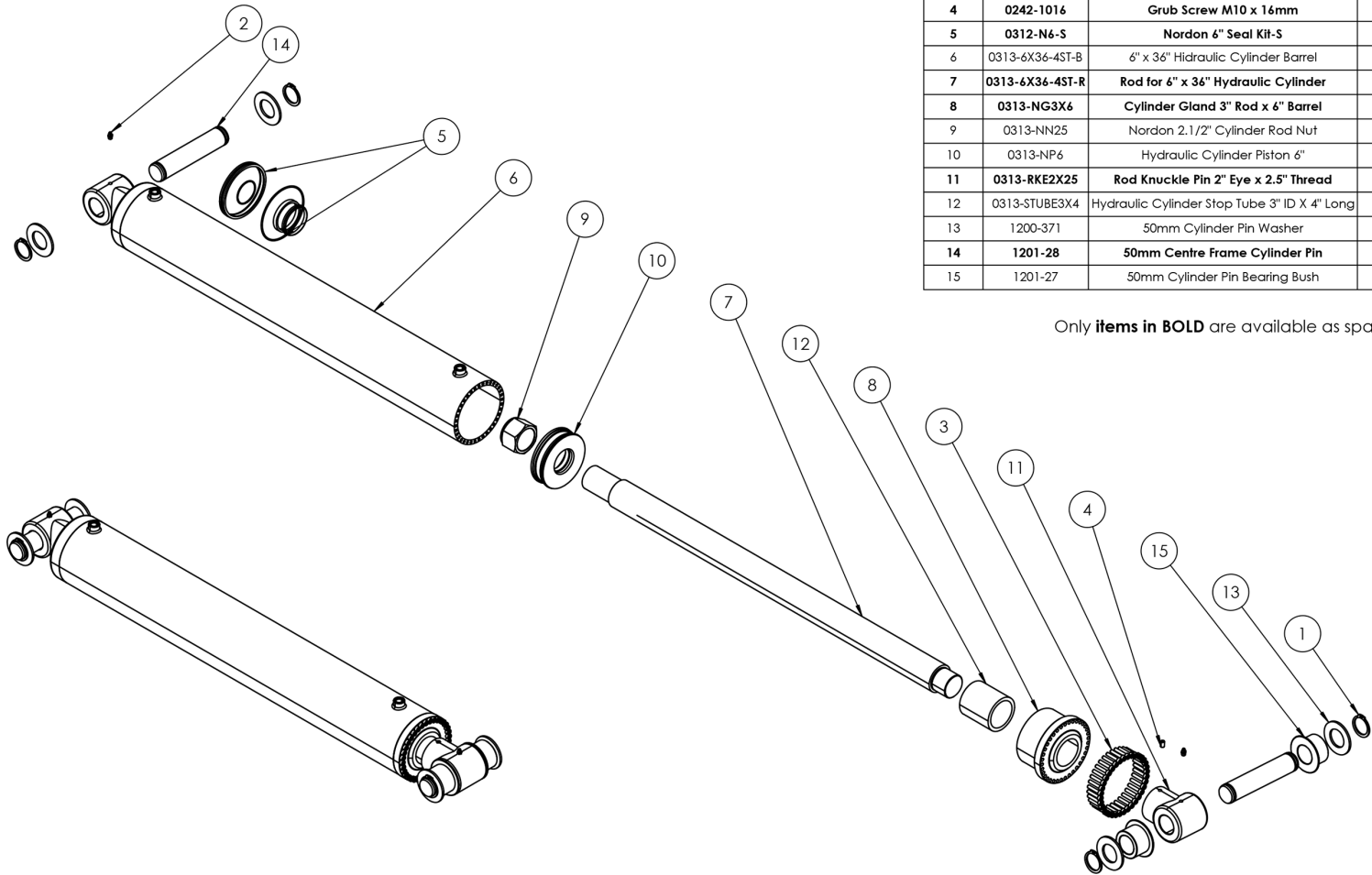

ITEM NO.	PART NUMBER	DESCRIPTION	Revision	QTY.
1	0172-D1400-50	Circlip External 50mm		4
2	0181-GN3-8	Grease Nipple 3/8"		2
3	0211-SH840	Socket Head Bolt M8 x 40		36
4	0242-1016	Grub Screw M10 x 16mm		1
5	0312-N6-S	Nordon 6" Seal Kit-S	A-0	1
6	0313-6X36-4ST-B	6" x 36" Hydraulic Cylinder Barrel		1
7	0313-6X36-4ST-R	Rod for 6" x 36" Hydraulic Cylinder		1
8	0313-NG3X6	Cylinder Gland 3" Rod x 6" Barrel		1
9	0313-NN25	Nordon 2.1/2" Cylinder Rod Nut		1
10	0313-NP6	Hydraulic Cylinder Piston 6"		1
11	0313-RKE2X25	Rod Knuckle Pin 2" Eye x 2.5" Thread		1
12	0313-STUBE3X4	Hydraulic Cylinder Stop Tube 3" ID X 4" Long		1
13	1200-371	50mm Cylinder Pin Washer	B-0	4
14	1201-28	50mm Centre Frame Cylinder Pin	B-0	2
15	1201-27	50mm Cylinder Pin Bearing Bush	A-0	2

Only items in **BOLD** are available as spare parts



Part Number	Description	For Machines Built:	Revision
0311-6X36-4ST	6" Bore x 36" Stroke 3" Rod Cylinder with 4" Stop Tube		C-0

Hydraulic Cylinder Supplement Parts Manual Index - EzyFit

Nordon cylinders are currently used on Kelly frames and supersede previous EzyFit cylinders, as outlined below.

EzyFit spare parts are still available for your existing cylinders and include clevises, rods, seal kits and some pistons as outlined below:

Page No.	EzyFit Cylinder	Seal Kit Number	Description	Clevis	Rod	Gland	Piston	Current Nordon Offering
34	0311-5041	0312-EF0006	2.5" Bore x 6" Stroke 1.5" Rod Side Port	0313-6002C	0313-5041R	0313-5041G 0313-5041GN = nut	0313-5041P	0311-256SP
35	0311-6002*	0312-EF0054	3" Bore x 12" Stroke 1.5" Rod Extended	0313-6002C	0313-6002R	0313-2957G 0313-2957GN = nut		0311-312EXT
36	0311-2957	0312-EF0054	3" Bore x 24" Stroke 1.5" Rod	0313-6002C	0313-2957R	0313-2957G 0313-2957GN = nut	0313-2957P	0311-324
37	0311-2958	0312-EF0202	3.5" Bore x 24" Stroke 1.75" Rod Side Port	0313-6002C	0313-2958R	0313-2958G 0313-2958GN = nut	0313-2958P	0311-3524SP
38	0311-6896	0312-EF0202	3.5" Bore x 32" Stroke 1.75" Rod with 4" Stop Tube	0313-6896C				0311-3532ST
39	0311-6357*	0312-EF0316	4" Bore x 12" Stroke 1.75" Rod Extended	0313-6357C 0313-6357CP = with spacers	0313-6357R	0313-6357G	0313-6357P	0311-412EXT
	0311-2938**	0312-EF0316	4" Bore x 8" Stroke	0313-6357C	0313-2938R	0313-6357G	0313-6357P	
40	0311-3786	0312-EF0316	4" Bore x 24" Stroke 1.75" Rod			0313-6357G	0313-6357P	0311-424
41	0311-4781	0312-EF2960	4" Bore x 30" Stroke 1.75" Rod with 3" Stop Tube		0313-4781R	0313-2960G	0313-2960P	0311-430ST
42	0311-5040	0312-EF2956	5" Bore x 30" Stroke 2" Rod with 3" Stop Tube	0313-2956K	0313-5040R	0313-5040G	0313-5040P	0311-530ST
43	0311-2956	0312-EF2956	5" Bore x 36" Stroke 2" Rod with 3" Stop Tube	0313-2956K	0313-2956R	0313-5040G	0313-5040P	0311-536ST
44	0311-2960**	0312-EF2960			0313-2960R	0313-2960G	0313-2960P	

* 1/2" Tubeline for 6002, 6357 cylinders = 0313-6002TUBE

** Drawing is not available

ITEM NO.	PART NUMBER	Revision	DESCRIPTION	QTY.
1	0312-EF0006		Seal Kit 2.5"	1
2	0313-5041B	A	2.5" x 6" Cylinder Barrel Side Port	1
3	0313-5041R	A	2.5" x 6" Cylinder Rod	1
4	0313-6002C		Clevis For 2957- 5041- 6002- 2958 Cylinders	1
5	0511-RCLIP4		R Clip 4mm	2
6	0801-44082938	A	Clevis Pin 1" x 75mm	2

Only **items in BOLD** are available as spare parts

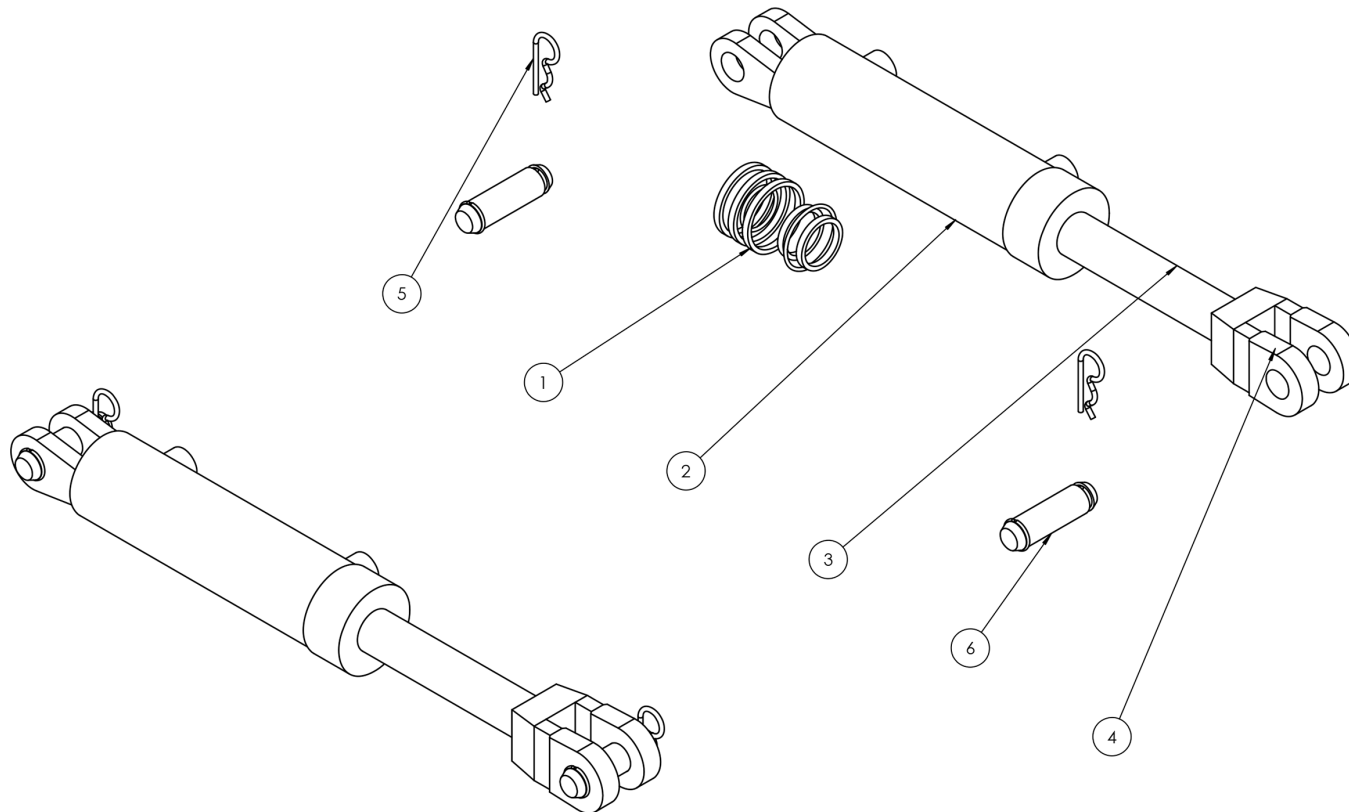

KELLY

Part Number
0311-5041

Description
Hyd Cylinder 2.5" x 6" Side Port

For Machines Built:
All(2008)-

Revision
A

ITEM NO.	PART NUMBER	Revision	DESCRIPTION	QTY.
1	0211-12110SHSCREW	A	Shoulder Screw M12 x 16 x 110	2
2	0231-SPRINGCUP		Compression Cup Washer	7
3	0312-EF0054		Seal Kit 3"	1
4	0313-6002B		3" x 12" EXT Cylinder Barrel	1
5	0313-6002C		Clevis For 2957- 5041- 6002- 2958 Cylinders	1
6	0313-6002R		3" x 12" Cylinder Rod	1
7	0313-6357CPLATE		Mount Plate For 6357 Cylinder Spacers	1
8	0341-6114063	A	3:1 Pilot Ratio- Counterbalance Valve	1
9	0511-RCLIP4		R Clip 4mm	2
10	0800-278		Cylinder Depth Stop Plate	10
11	0801-44082938	A	Clevis Pin 1" x 75mm	2

Only **items in BOLD** are available as spare parts

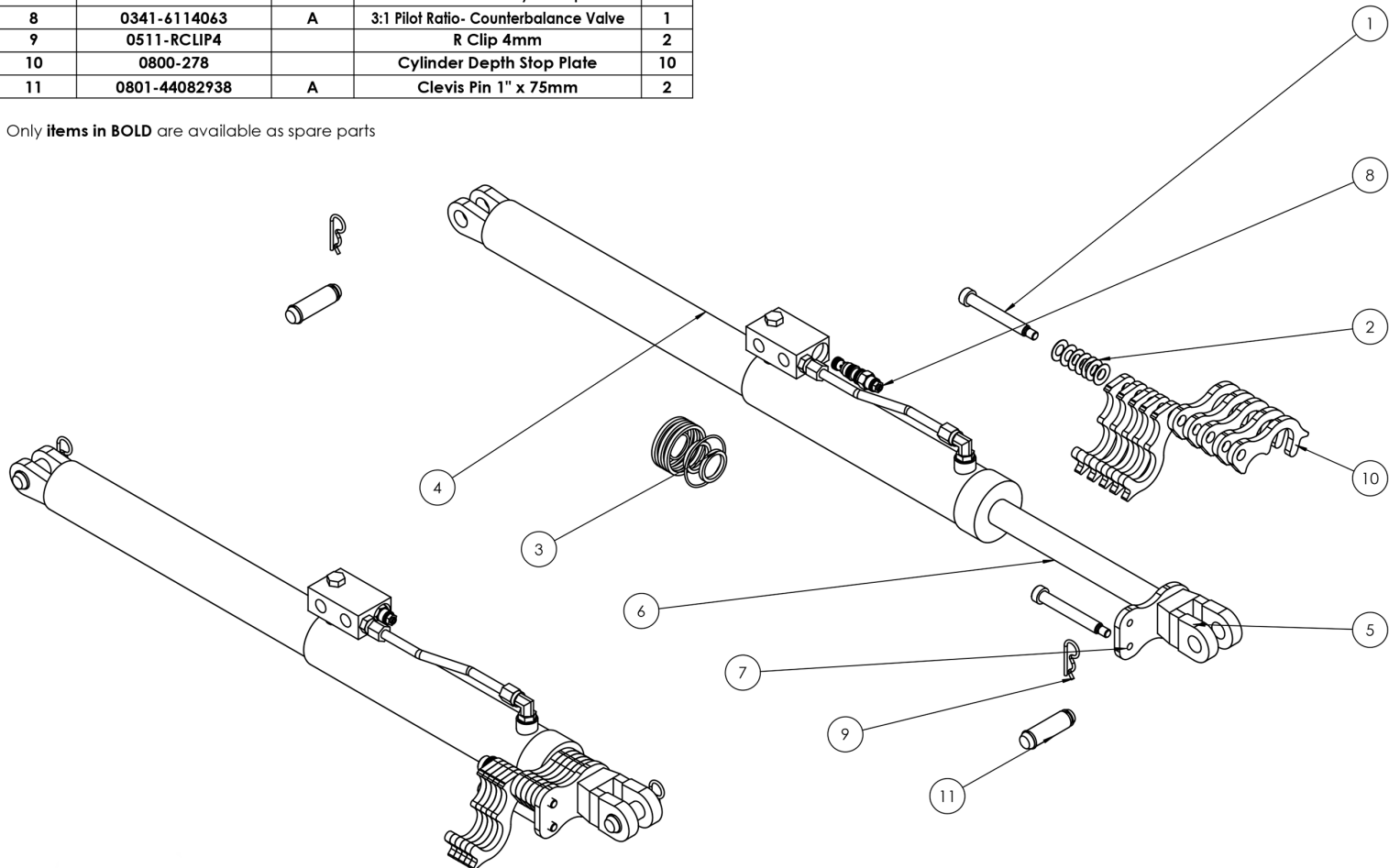

KELLY

Part Number	Description	For Machines Built:	Revision
0311-6002	Hyd Cylinder 3 x 12 Extended	All (2008)-	A

ITEM NO.	PART NUMBER	Revision	DESCRIPTION	QTY.
1	0312-EF0054		Seal Kit 3"	2
2	0313-2957B		3" x 24" Cylinder Barrel	1
3	0313-2957R		3" x 24" Cylinder Rod	1
4	0313-6002C		Clevis For 2957- 5041- 6002- 2958 Cylinders	1
5	0511-RCLIP4		R Clip 4mm	2
6	0801-44082938	A	Clevis Pin 1" x 75mm	2

Only **items in BOLD** are available as spare parts

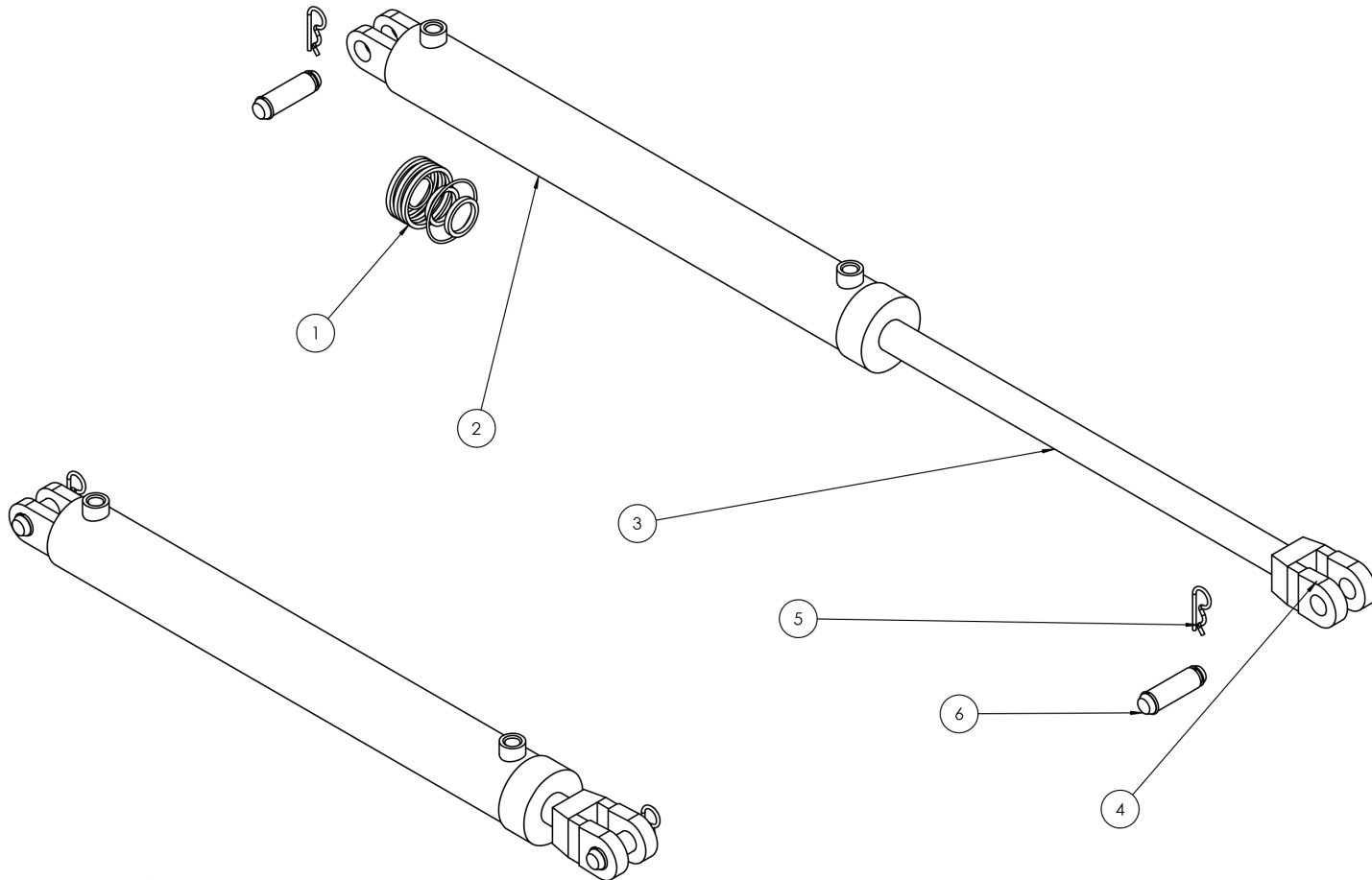

KELLY

Part Number
0311-2957

Description
3" x 24" Hydraulic Cylinder

For Machines Built:

Revision
A

ITEM NO.	PART NUMBER	Revision	DESCRIPTION	QTY.
1	0312-EF0202		Seal Kit 3.5"	1
2	0313-2958B	A	3.5" x 24" Hydraulic Cylinder Barrel	1
3	0313-2958R	A	3.5" x 24" Hydraulic Cylinder Rod	1
4	0313-6002C		Clevis For 2957- 5041- 6002- 2958 Cylinders	1
5	0511-RCLIP4		R Clip 4mm	2
6	0801-44082938	A	Clevis Pin 1" x 75mm	2

Only **items in BOLD** are available as spare parts

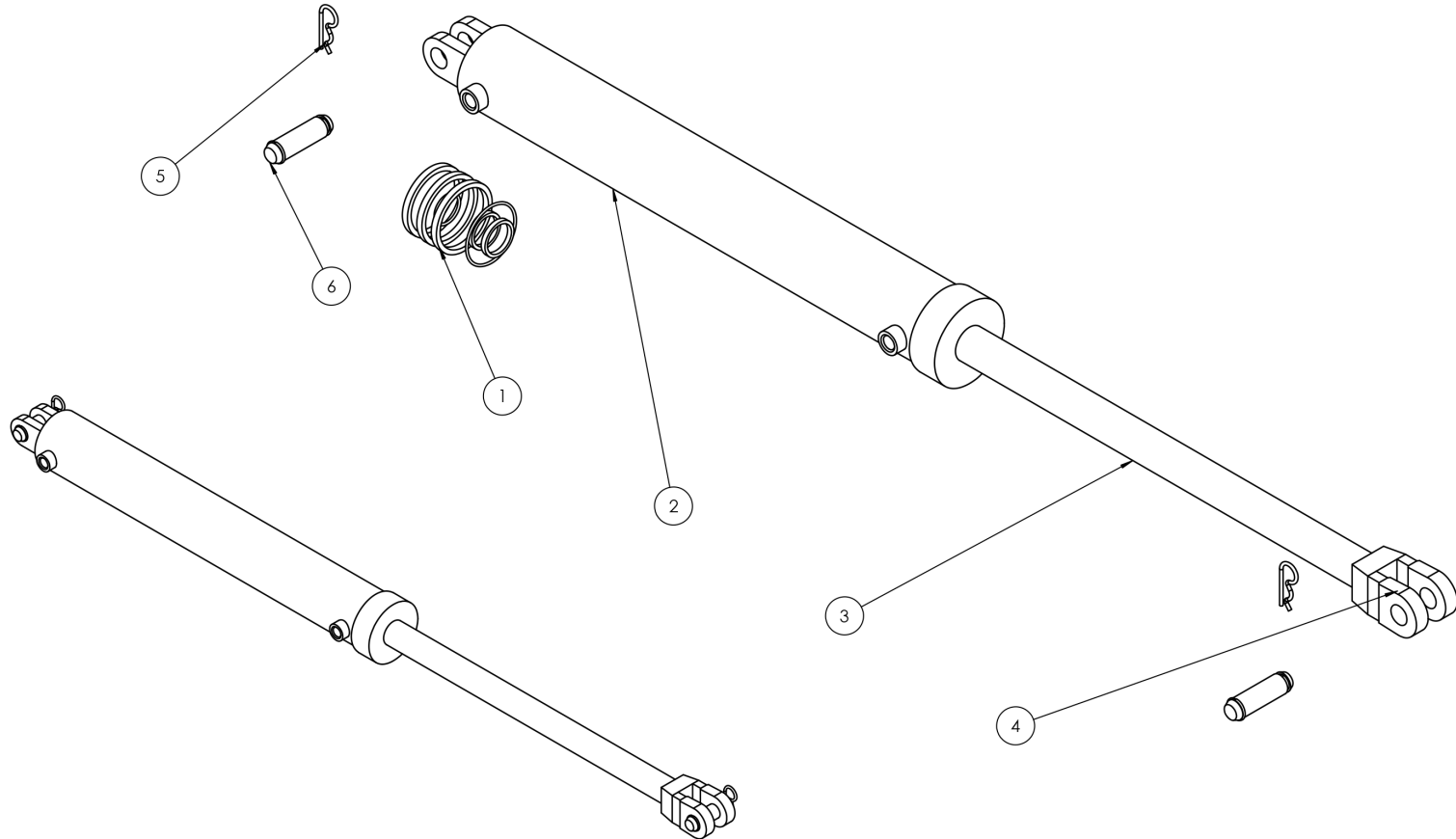

KELLY

Part Number
0311-2958

Description
Hyd Cylinder 3.5" x 24"

For Machines Built:
65'(112043-65)-

Revision
B

ITEM NO.	PART NUMBER	Revision	DESCRIPTION	QTY.
1	0232-F11-4		Washer Flat 1 1/4"	2
2	0312-EF0202		Seal Kit 3.5"	1
3	0313-6896B	A	3.5" x 32" Hydraulic Cylinder Barrel	1
4	0313-6896C		Clevis For 6896 Cylinder	1
5	0313-6896R	A	3.5" X 32" Hydraulic Cylinder Rod	1
6	0801-44103786	A	Cylinder Pin 1 1/4" x 94mm	2
5	0801-KE012	A	S Locking Pin Clip 5mm	2

Only **items in BOLD** are available as spare parts

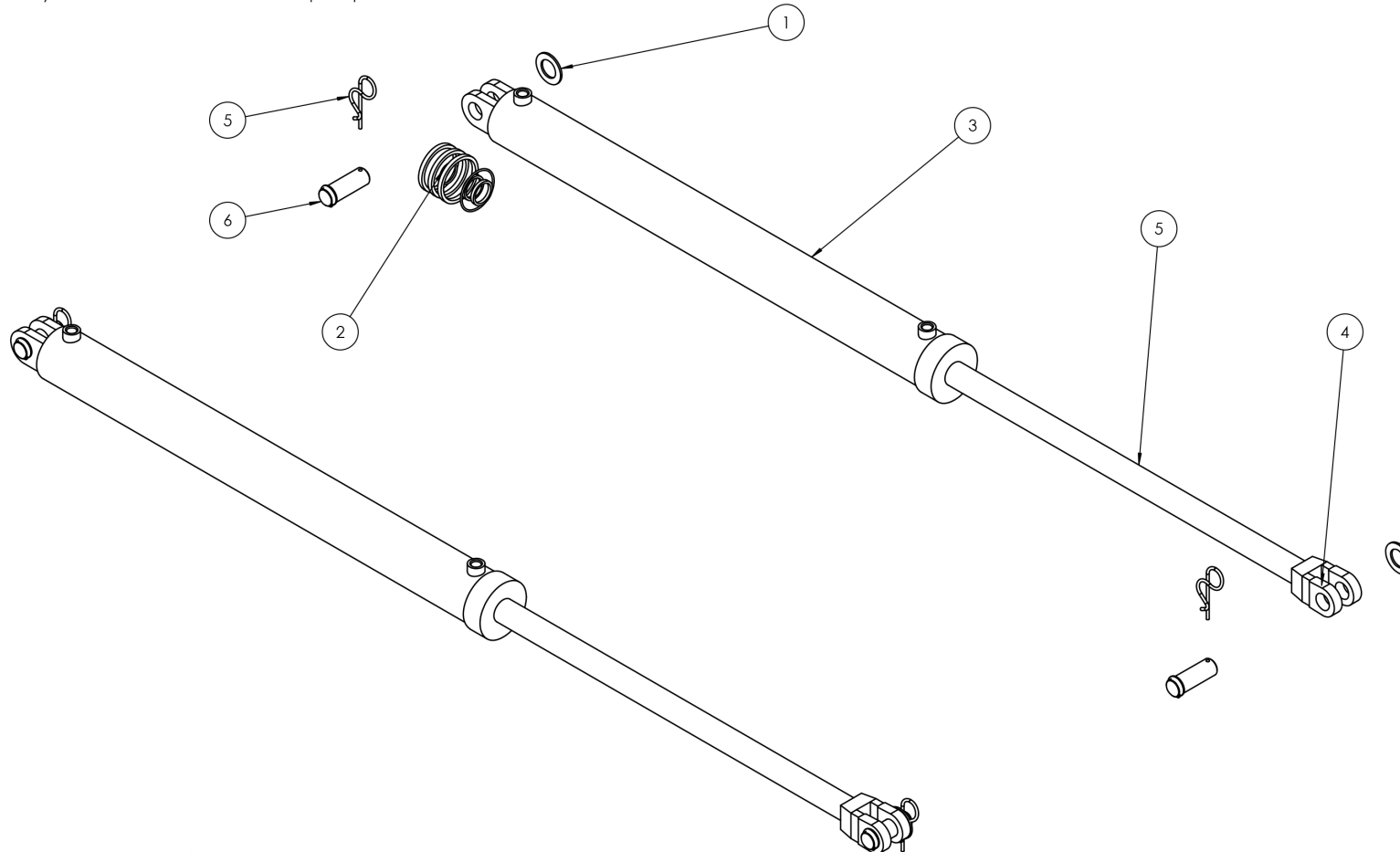

KELLY

Part Number	Description	For Machines Built:	Revision
0311-6896	Hyd Cylinder 3.5" x 32" + 4" Stop Tube	65'(112043-65 -) 60CT(113060-60CT -)	A

ITEM NO.	PART NUMBER	Revision	DESCRIPTION	QTY.
1	0211-12110SHSCREW	A	Shoulder Screw M12 x 16 x 110	2
2	0231-SPRINGCUP		Compression Cup Washer	7
3	0312-EF0316		Seal Kit 4"	1
4	0313-6357B		4" x 12" EXT Cylinder Barrel	1
5	0313-6357C		Clevis For 3786 Cylinder	1
6	0313-6357CPLATE		Mount Plate For 6357 Cylinder Spacers	1
7	0313-6357R	B	4" x 12" Cylinder Rod	1
8	0341-6114063	A	3:1 Pilot Ratio- Counterbalance Valve	1
9	0511-RCLIP4		R Clip 4mm	2
10	0800-278		Cylinder Depth Stop Plate	10
11	0801-44082938	A	Clevis Pin 1" x 75mm	2

Only items in **BOLD** are available as spare parts

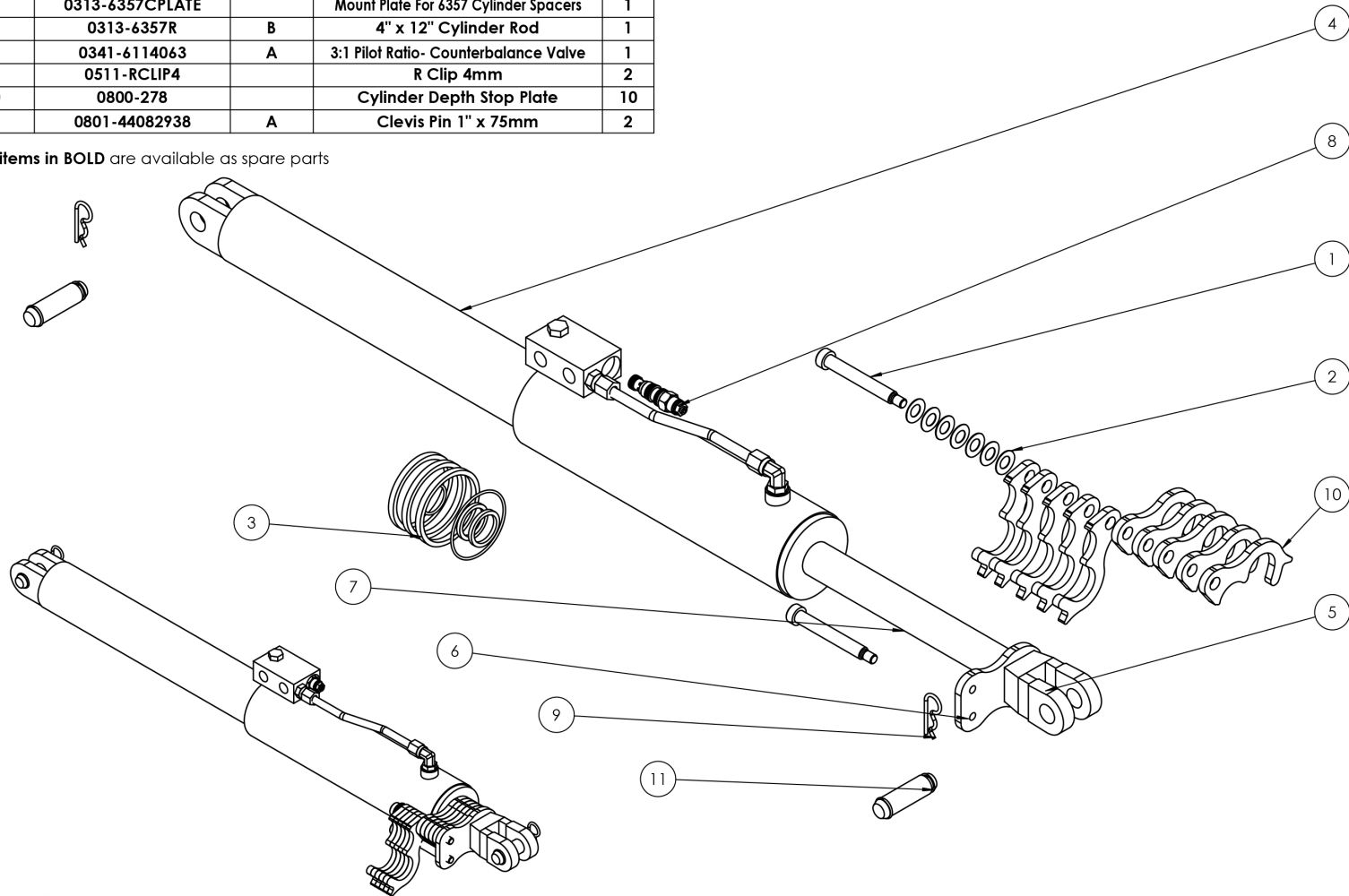

KELLY

Part Number	Description	For Machines Built:	Revision
0311-6357	Hyd Cylinder 4 x 12 Extended	50/60 (1110200-60)-	A

ITEM NO.	PART NUMBER	Revision	DESCRIPTION	QTY.
1	0312-EF0316		Seal Kit 4"	1
2	0313-3786B		4" x 24" Cylinder Barrel	1
3	0313-3786C		Clevis For 3786 Cylinder	1
4	0313-3786R		4" x 24" Cylinder Rod	1
5	0801-44103786	A	Cylinder Pin 1 1/4" x 94mm	2
6	0801-KE012	A	S Locking Pin Clip 5mm	2

Only **items in BOLD** are available as spare parts

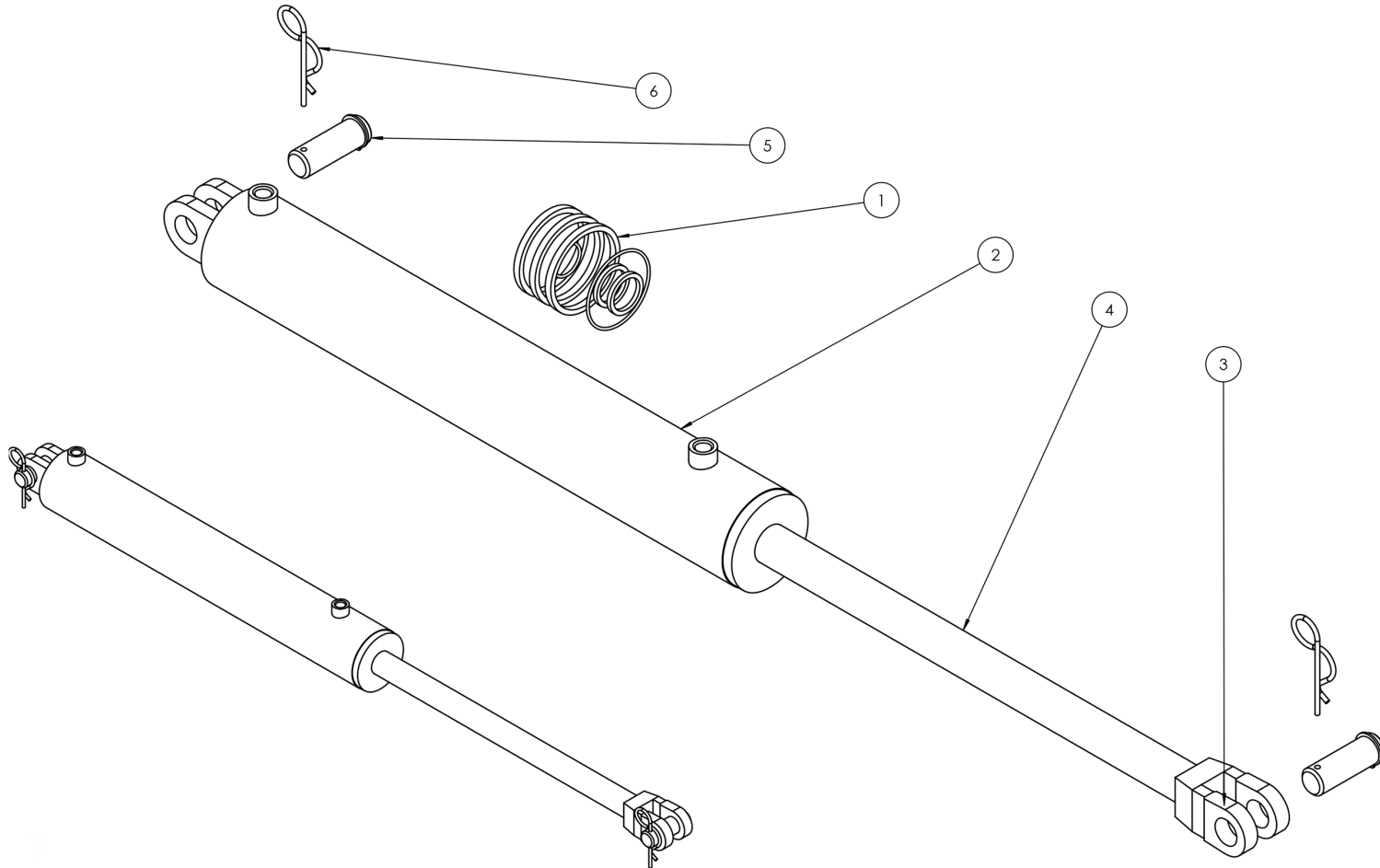

KELLY

Part Number	Description	For Machines Built:	Revision
0311-3786	4" x 24" Hydraulic Cylinder		A

ITEM NO.	PART NUMBER	Revision	DESCRIPTION	QTY.
1	0232-F11-4		Washer Flat 1 1/4"	3
2	0312-EF2960		Seal Kit 4"	1
3	0313-4781B		4" x 30" Hydraulic Cylinder Barrel	1
4	0313-4781R		4" x 30" Hydraulic Cylinder Rod	1
5	0801-44102956-1	B	Cylinder Pin 1 1/4" x 230mm 4140	1
6	0801-44102956-2	A	Cylinder Pin 1 1/4" x 116mm	1
7	0801-KE012	A	S Locking Pin Clip 5mm	3

Only **items in BOLD** are available as spare parts

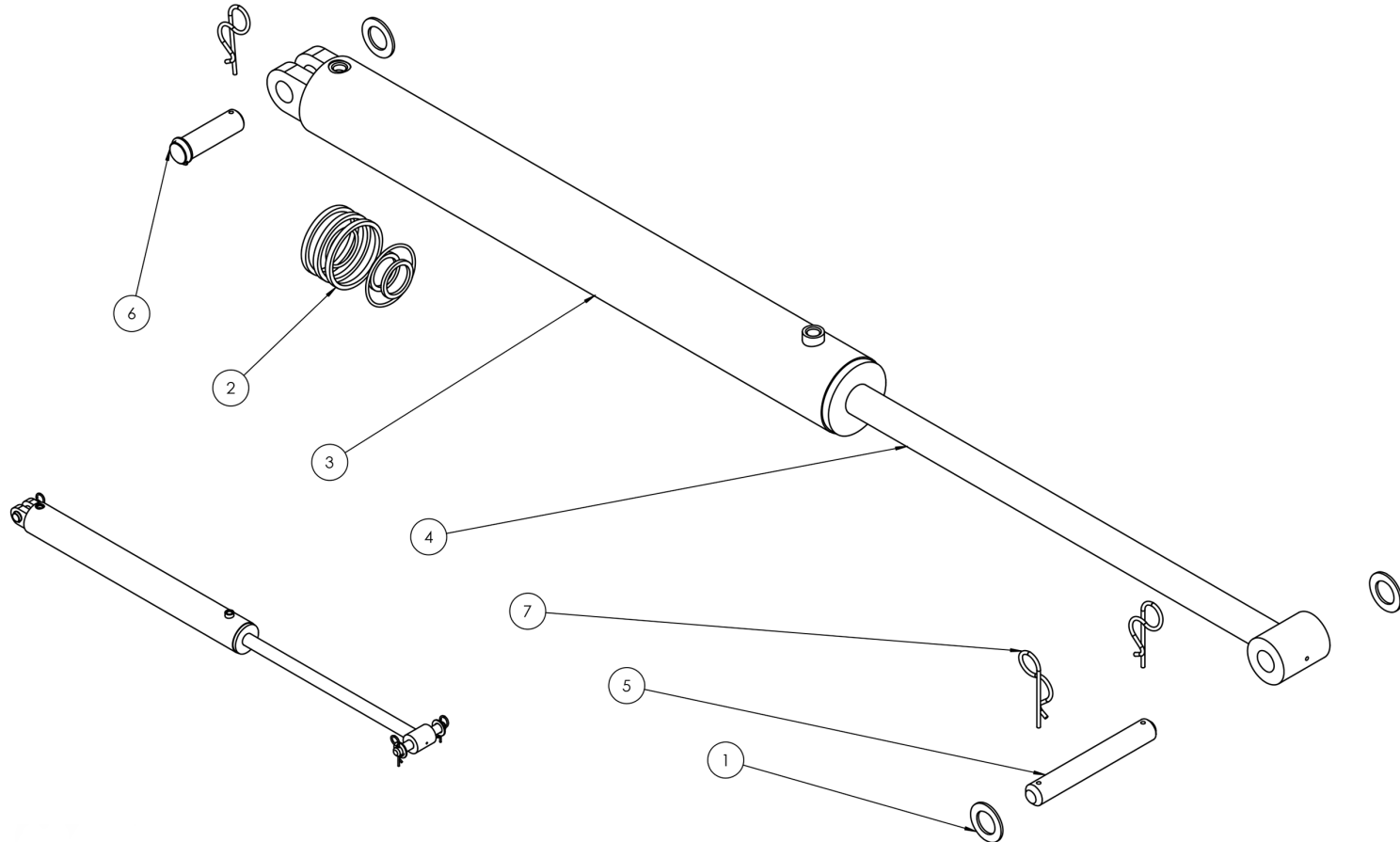

KELLY

Part Number
0311-4781

Description
4" x 30" Hydraulic Cylinder

For Machines Built:
30' Only

Revision
A

ITEM NO.	PART NUMBER	Revision	DESCRIPTION	QTY.
1	0181-GN1-4		Grease Nipple 1/4" UNF	1
2	0232-F11-4		Washer Flat 1 1/4"	3
3	0312-EF2956		Seal Kit 5"	1
4	0313-5040B		5" x 30" Cylinder Barrel	1
5	0313-5040R		5" x 30" Cylinder rod	1
6	0801-44102956-1	B	Cylinder Pin 1 1/4" x 230mm 4140	1
7	0801-44102956-2	A	Cylinder Pin 1 1/4" x 116mm	1
8	0801-KE012	A	S Locking Pin Clip 5mm	3

Only **items in BOLD** are available as spare parts

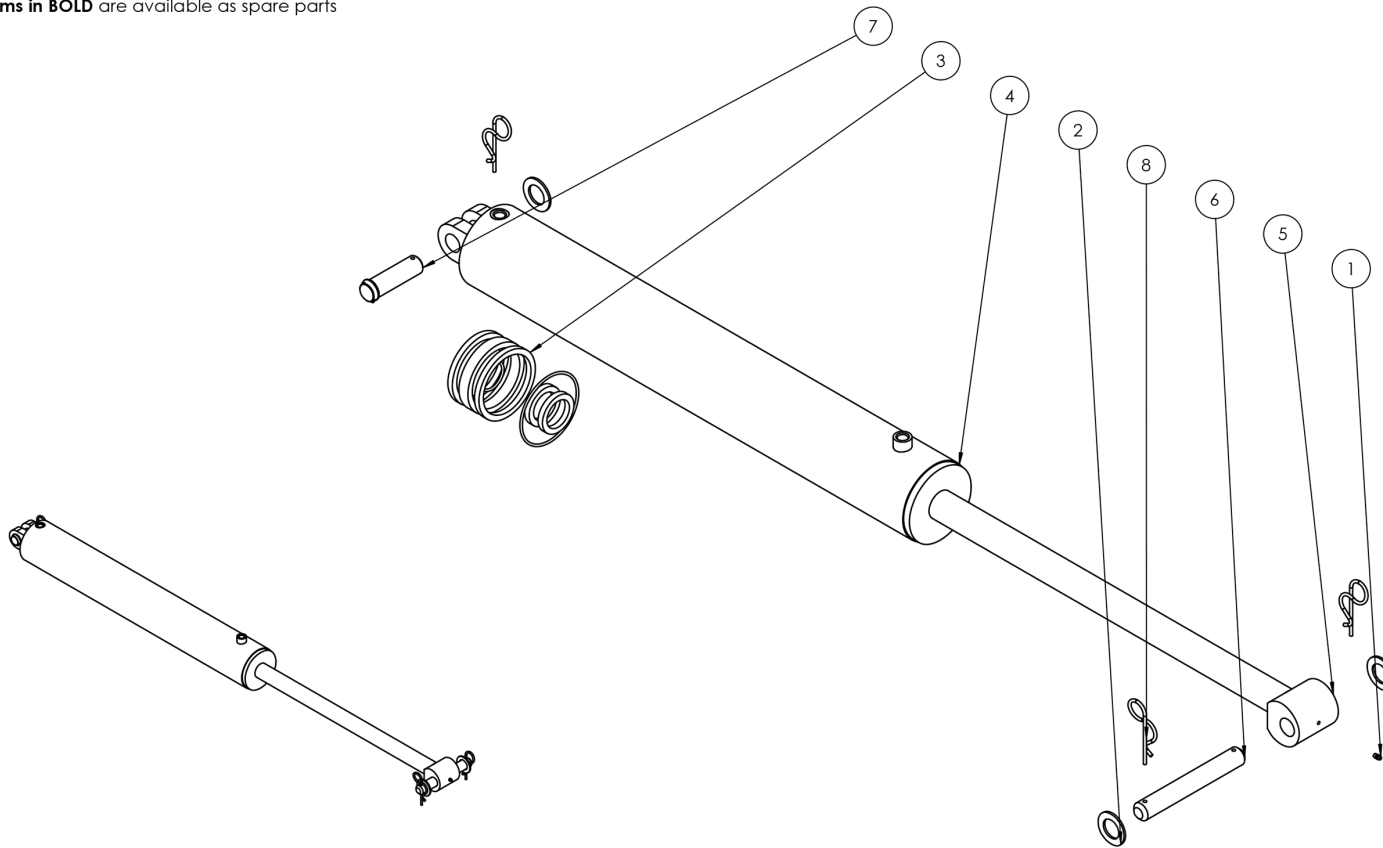

KELLY

Part Number
0311-5040

Description
5" x 30" Hydraulic Cylinder

For Machines Built:

Revision
A

ITEM NO.	PART NUMBER	Revision	DESCRIPTION	60CT/QTY.
1	0232-F11-4		Washer Flat 1 1/4"	3
2	0312-EF2956		Seal Kit 5"	1
3	0313-2956B	A	5" x 36" Hydraulic Cylinder Barrel	1
4	0313-2956R	A	5" x 36" Hydraulic Cylinder Rod	1
5	0801-44102956-1	B	Cylinder Pin 1 1/4" x 230mm 4140	1
6	0801-44102956-2	A	Cylinder Pin 1 1/4" x 116mm	1
7	0801-KE012	A	S Locking Pin Clip 5mm	3
8	1201-18	A	Long Cylinder Pin	1
9	1201-19	A	Long Cylinder Pin Bearing Bush	2

Only **items in BOLD** are available as spare parts

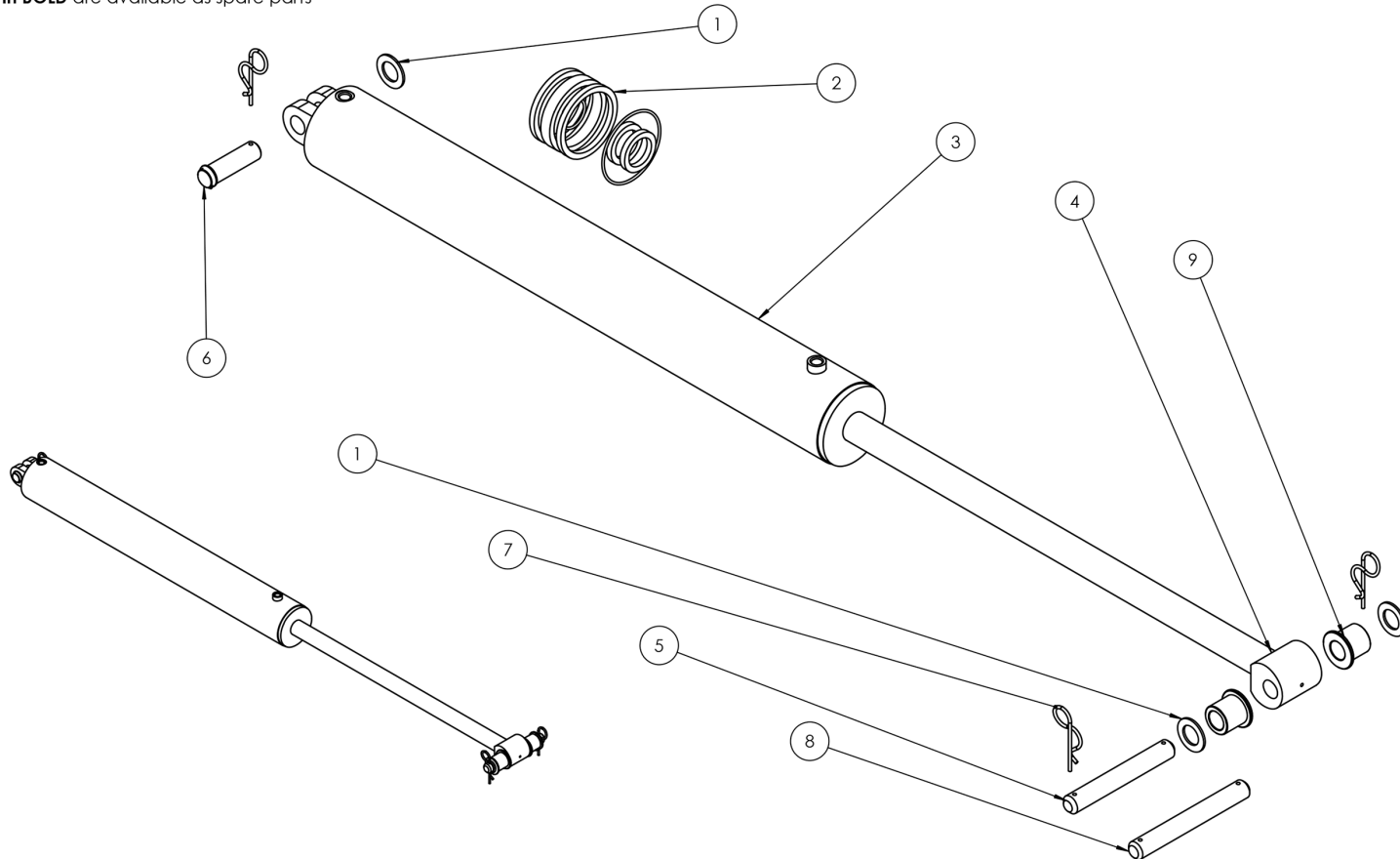

KELLY

Part Number	Description	For Machines Built:	Revision
0311-2956	Hyd Cylinder 5" x 36"	65'(112043-65)- & 60CT(113060-60CT)-	A

Cylinder Service Procedure

Tools Required:

- Cylinder Component Diagram
- 6" Chain Vice bolted to a Bench
- 'C' Spanner suitable for diameter of Cylinder
- Scriber
- Blunt Screw Driver
- Torch
- Cleaning Solution
- **Drain Tray**
- **Air Gun**
- **Soft Hammer**
- **Torque Rench**
- **Adjustable Stand to support Shaft**
- **Socket required for bore size**
- **1.5" Bore = 7/8"**
- **2.0" Bore = 1.1/16"**
- **2.5" Bore = 1.7/16"**
- **3.0" Bore = 1.5/8"**
- **3.5" Bore = 1.13/16"**
- **4.0" Bore = 2.1/4"**

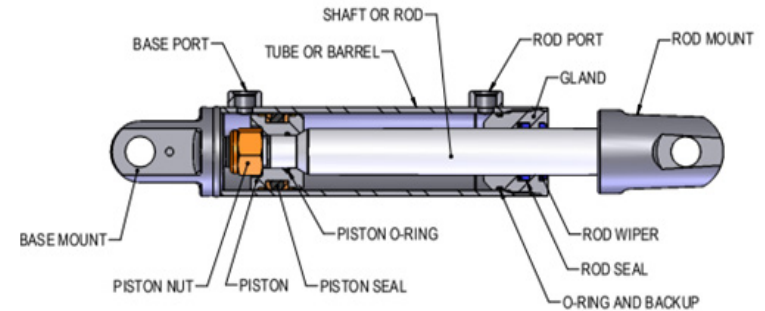

1. Drain oil from cylinder
2. Secure cylinder in chain vice
3. Fully extend the rod carefully by placing air pressure into rear port of cylinder
4. *****Warning: Ensure gland has not been removed or loosened before extending with air*****
5. Remove gland from barrel with 'C' spanner, ensuring rod is supported (see image)
6. Remove rod assembly from barrel (Take note of piston seal may be cut on rod port when removing from barrel) (see image)
7. Clamp rod in vice while supporting rod on stand (ensuring shaft is protected from damage)
8. Remove piston nut, piston and gland from rod
9. Remove seals from piston using a blunt screwdriver, ensuring seal removal tool does not damage seal area on piston. (Take note of position of seals and direction parts face)
10. Remove O-ring from internal diameter of piston
11. Remove rod wiper and rod seal from gland with scriber, ensuring seal removal tool does not damage seal groove in gland. Insert scriber into centre of seal and prize out. Take note of the direction of seal faces
12. Remove O-ring and back-up ring from gland outer diameter, noting position of each and direction back-up ring faces



Step 5



Step 6

Cylinder Service Procedure

13. Clean all parts

14. Inspect all parts for damage. Check:

- gland seal & O-ring groove is clean and in good condition, no scratches or rust,
- piston is clean and in good condition, no scratches or rust on seal areas and no damage to outer diameter of piston
- rod is clean and in good condition, no scratches on shaft, not bent, no damage to thread
- piston does not have excessive clearance (max 0.15mm)
- tube is clean with no scores in bore, no rust, no damage to O-ring seal area or thread

15. Install rod seal into gland seal groove, innermost groove, with seal facing pressure side of gland (see drawing)

16. Install rod wiper into gland (outer groove)

17. Install O-ring & back up washer to outside of gland

18. Install piston seals onto piston (see drawing)

19. Install O-ring to groove inside piston

20. Lubricate piston seals and gland seals with hydraulic oil

21. Install gland onto rod with wiper seal of gland going on first

22. Install piston onto shaft with taper end on first

23. Install new Nyloc Nut and tension to

1.5" Bore = 27Nm

3.0" Bore = 344Nm

2.0" Bore = 203Nm

3.5" Bore = 417Nm

2.5" Bore = 324Nm

4.0" Bore = 720Nm

24. Lubricate inside of barrel with hydraulic oil

25. Place rod assembly into cylinder (ensuring seal is not damaged on thread or port hole)

26. Tap rod assembly in halfway up the barrel to allow gland to be screwed in

27. Lubricate gland O-ring & back-up ring and ensure tube is lubricated and coat threads and bearing area of gland with 'Anti-Seize'

28. Install gland into barrel and tighten up with 'C' Spanner ensuring gland locks up to end of barrel and tension to:

1.5" Bore = 236Nm
3.0" Bore = 1895Nm

2.0" Bore = 560Nm
3.5" Bore = 3010Nm

2.5" Bore = 1090Nm
4.0" Bore = 4494Nm



Phone +61 8 8667 2253
Email sales@kellytillage.com
kellytillage.com

Booleroo (Head Office)
684 Kelly Road,
Booleroo Centre SA 5482

Adelaide Office
28 Greenhill Road,
Wayville SA 5034

