



Diamond Chain Harrow Assembly and Parts Manual

Model 60CT/62

Revised December 2016

Kelly Engineering
PO Box 100
Booleroo Centre SA 5482
Australia

Phone: + 61 8 8667 2253

Fax: + 61 8 8667 2250

Email: office@kellyengineering.com.au

Website (US): www.kellyharrows.com

Website (Australia): www.kellyengineering.com.au



Thank you for choosing a Kelly Engineering product

We trust that you find the following manual clear and easy to follow. If you should require additional customer support or assistance, please do not hesitate to contact us.

Spare parts can be purchased, as required, through your local dealer or by contacting Kelly Engineering Australia or in the United States, Hood & Company.

Kelly Engineering welcomes feedback. Should you have any difficulties that you wish to raise, suggestions for improvement or modifications that you feel would enhance our products we look forward to hearing from you.

Australia

Kelly Engineering

PO Box 100

Booleroo Centre SA 5482

Phone: + 61 8 8667 2253

Fax: + 61 8 8667 2250

Email: sales@kellyengineering.com.au

Spare Parts: parts@kellyengineering.com.au

Website: www.kellyengineering.com.au

United States

Kelly Engineering

Website: www.kellyharrows.com

Spare Parts

Hood & Company Inc

Springfield MO

Phone: 417 865 2100

Fax: 417 865 2105

Email: hoodco@hoodco.com

Contents

	Page no
Section 1: Unpacking	4
Section 2: Assembly Step by Step	7-68
Section 3: Hydraulics set up	69
Charging hydraulic system	70
Hydraulic fitting identification	71
Hydraulic layout	72
Hydraulic detail	74-81
Section 4: Diagrams and charts	82
Wiring diagram	83
Mounting swivels	84
Fitting cast link retaining pins	85
Specifications	86-87
Section 5: Operation	88
Basic operation and chain tension	89
Module and chain tension	90
Correct working height	91
Assembly updates	92
Front cylinder depth stop	92
Hydraulic valve block	93
Rear light bracket	94
Brake disc collar	95
Correct hose attachment	96
CL2 chain configuration - All Machines	97
CL2 chain configuration - 60ft	98
CL2 disc chain procedure	99-101

Section 1

Unpacking

Unpacking

We recommend the use of suitable lifting equipment



- Before opening shipping container inspect exterior for any damage. Remove seal and open container doors.



CAUTION

Take care when opening doors as load may have shifted or restraints may have broken.

- Remove boxes from doorway of container one at a time using a forklift truck. Each box weighs approximately 2600 lbs (1200kg)
- Check strapping on each bundle before attempting to remove
- Attach chains to the packing frame using shackles and using suitable equipment (eg. fork-lift or tractor) drag framework bundles out of container. To move bundles away from front of container lift from side with forklift. Do not lift under angle iron frame, lift only under centre frame. Each bundle weighs approximately 7000 lb (3200 kg).

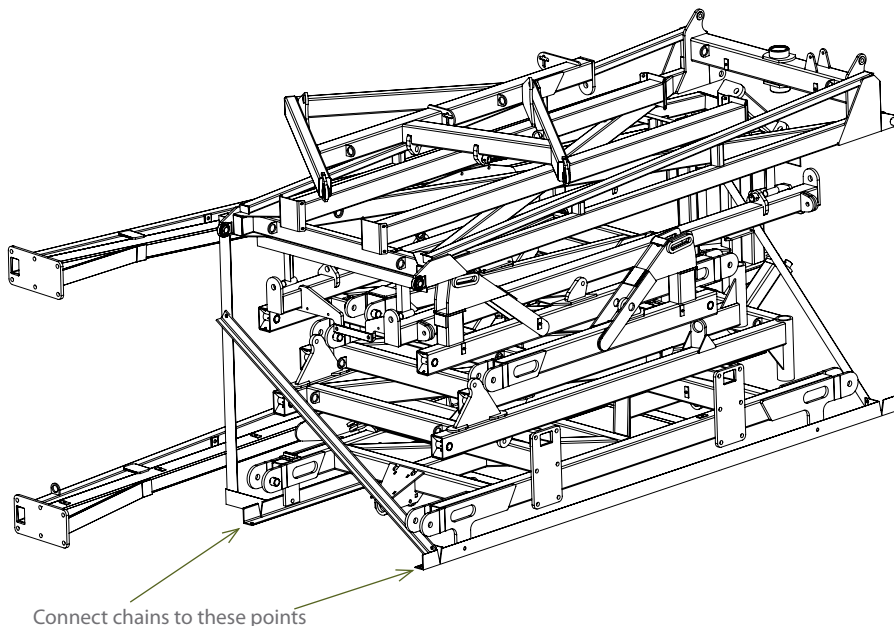

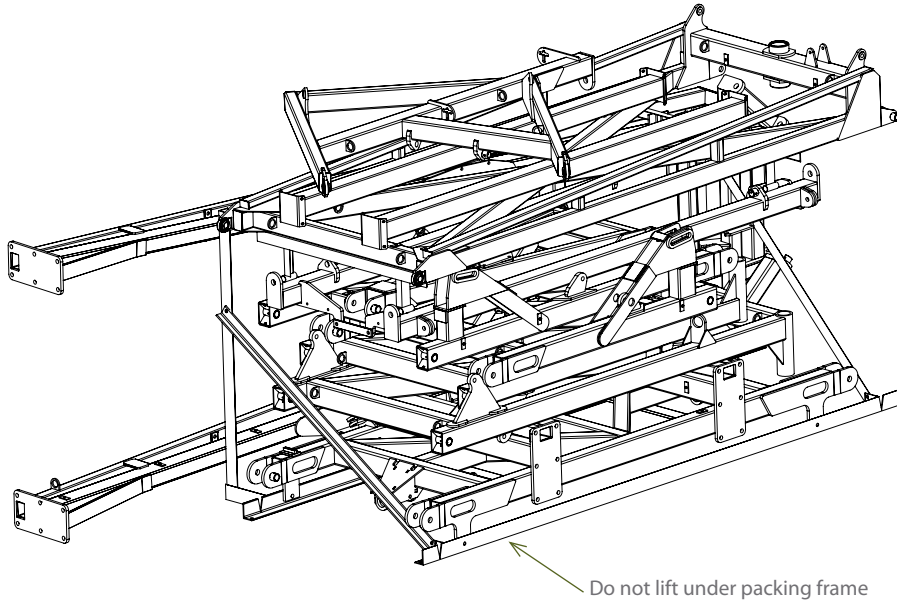

CAUTION

Before cutting straps attach slings or chains and take the weight of the frames to avoid them slipping or falling and causing injury.



CAUTION

Wear eye and hand protection when cutting straps. Sharp edges are exposed as straps separate and may cause injury.



CAUTION

To avoid falling or moving components, before cutting straps attach slings or chains to individual pieces and only cut the straps holding the piece to be lifted.

- Remove boxes from rear of container one at a time using a forklift truck. Each box weighs approximately 2600 lbs (1200 kg)
- Cut straps holding bundles and separate parts and place in assembly area
- Identify parts for each machine by serial no. or description and separate. Open parts box and check that all parts are accounted for against checklist
- Once all parts have been identified machines are ready for assembly
- Read assembly instructions before proceeding.

Section 2

Assembly Step by Step

ITEM NO.	PART NUMBER	DESCRIPTION	Qty
1	0860CT-01	60CT Centre Frame	1
2	0800-253	60CT Axle Mount Plate	4
3	0733-90	90 Series Stub Axle (Stub and Hub Complete)	4
4	0211-20130	M20 x 130 8.8 zp Bolt	4
5	0221-NYL20	M20 Nyloc Nut	4
6	0211-1650	M16 x 50 8.8 zp Bolt	16
7	0221-NYL16	M16 Nyloc Nut	16

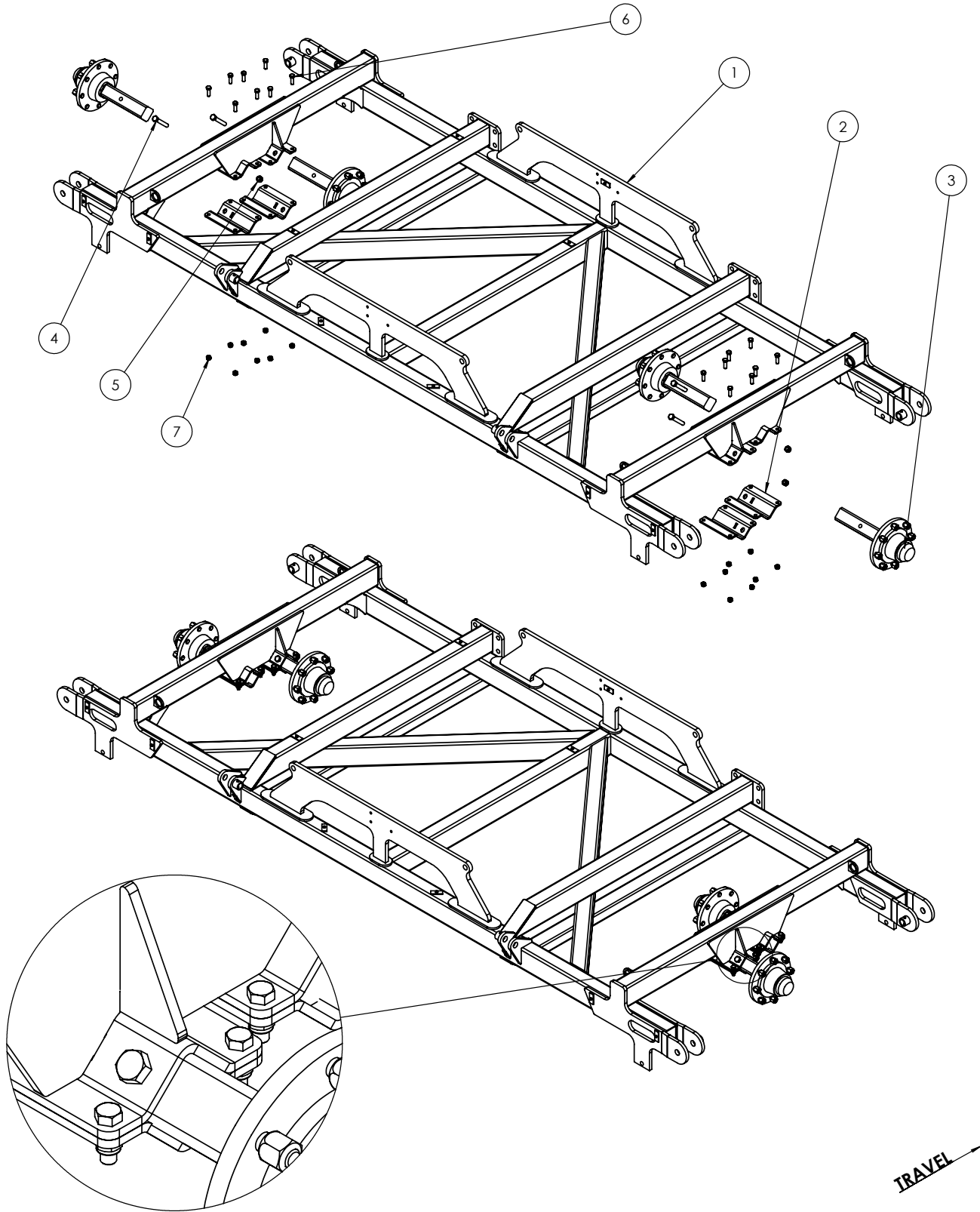

ITEM NO.	PART NUMBER	DESCRIPTION	Qty
1	0860CT-04	60CT RH Inner Wing Frame	1
2	0181-GN1-845	Grease Nipple 1/8" BSP 45 Deg	2
3	0801-10-08-235	PCH Wing Pivot Pin	2
4	0211-1265	M12 x 65 8.8 zp Bolt	2
5	0221-NYL12	M12 Nyloc Nut	2
6	0261-PINC1363	Cotter Pin M13 x 63	2
7	0113-MB 3550DX	35 ID x 50mm DX Bush	4

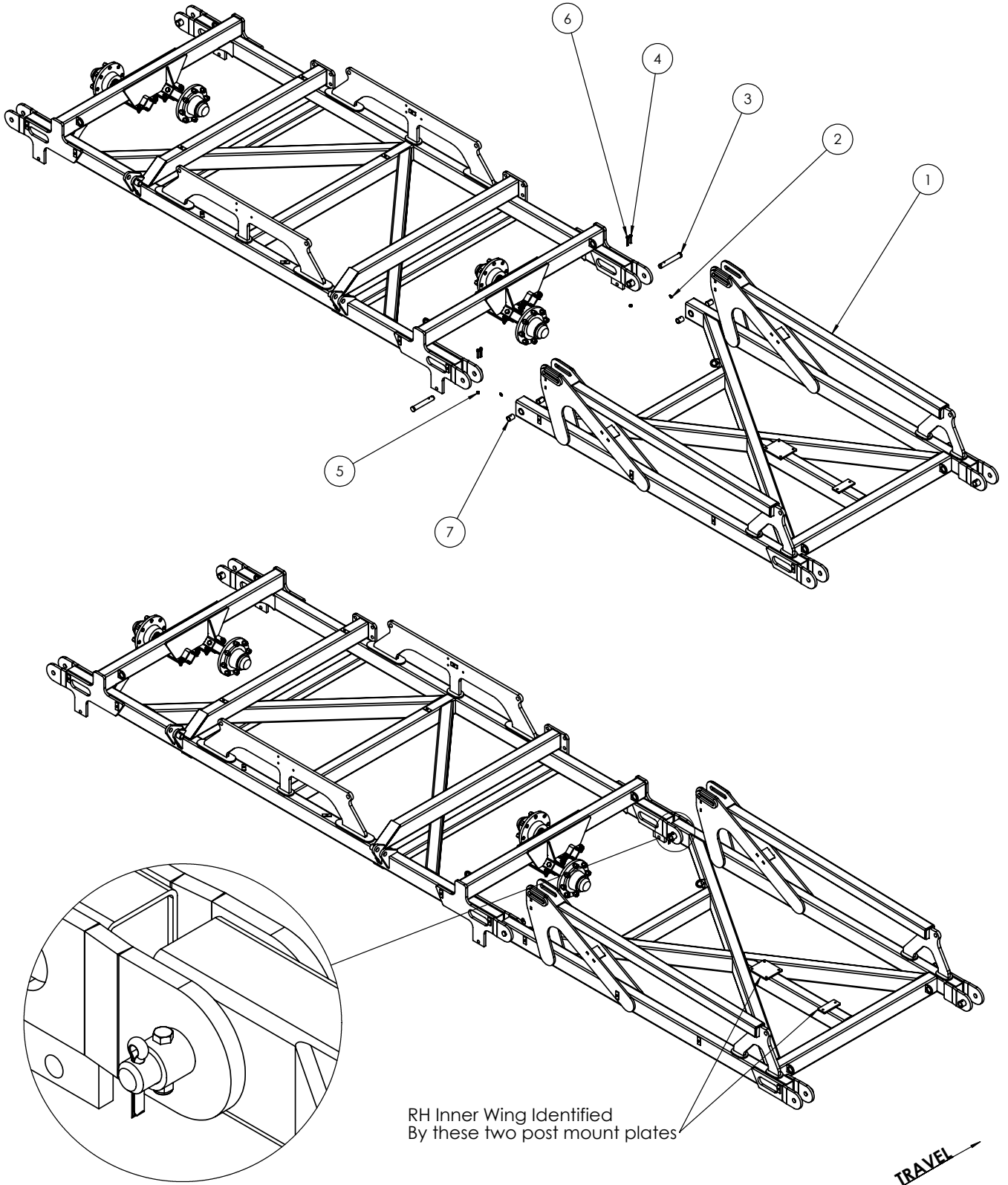

ITEM NO.	PART NUMBER	DESCRIPTION	Qty
1	0860CT-04P	60CT Inner Wing Post	1
2	0211-1250	M12 x 50 8.8 zp Bolt	6
3	0221-NYL12	M12 Nyloc Nut	6

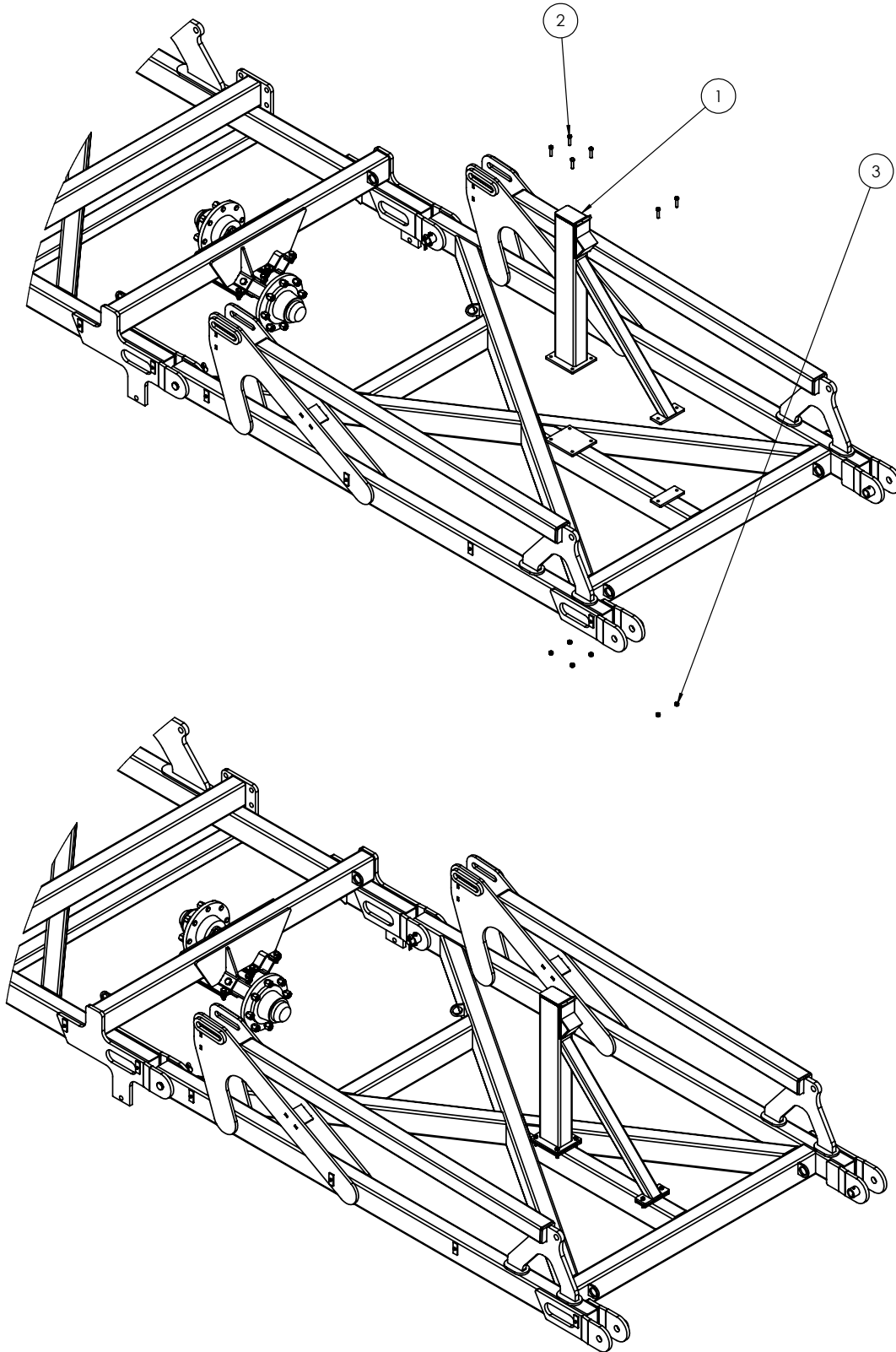

ITEM NO.	PART NUMBER	DESCRIPTION	Qty
1	0860CT-05	60CT LH Inner Wing Frame	1
2	0211-1265	M12 x 65 8.8 zp Bolt	2
3	0221-NYL12	M12 Nyloc Nut	2
4	0261-PINC1363	Cotter Pin M13 x 63	2
5	0181-GN1-845	Grease Nipple 1/8" BSP 45 Deg	2
6	0801-10-08-235	PCH Wing Pivot Pin	2
7	0113-MB 3550DX	35 ID x 50mm DX Bush	4

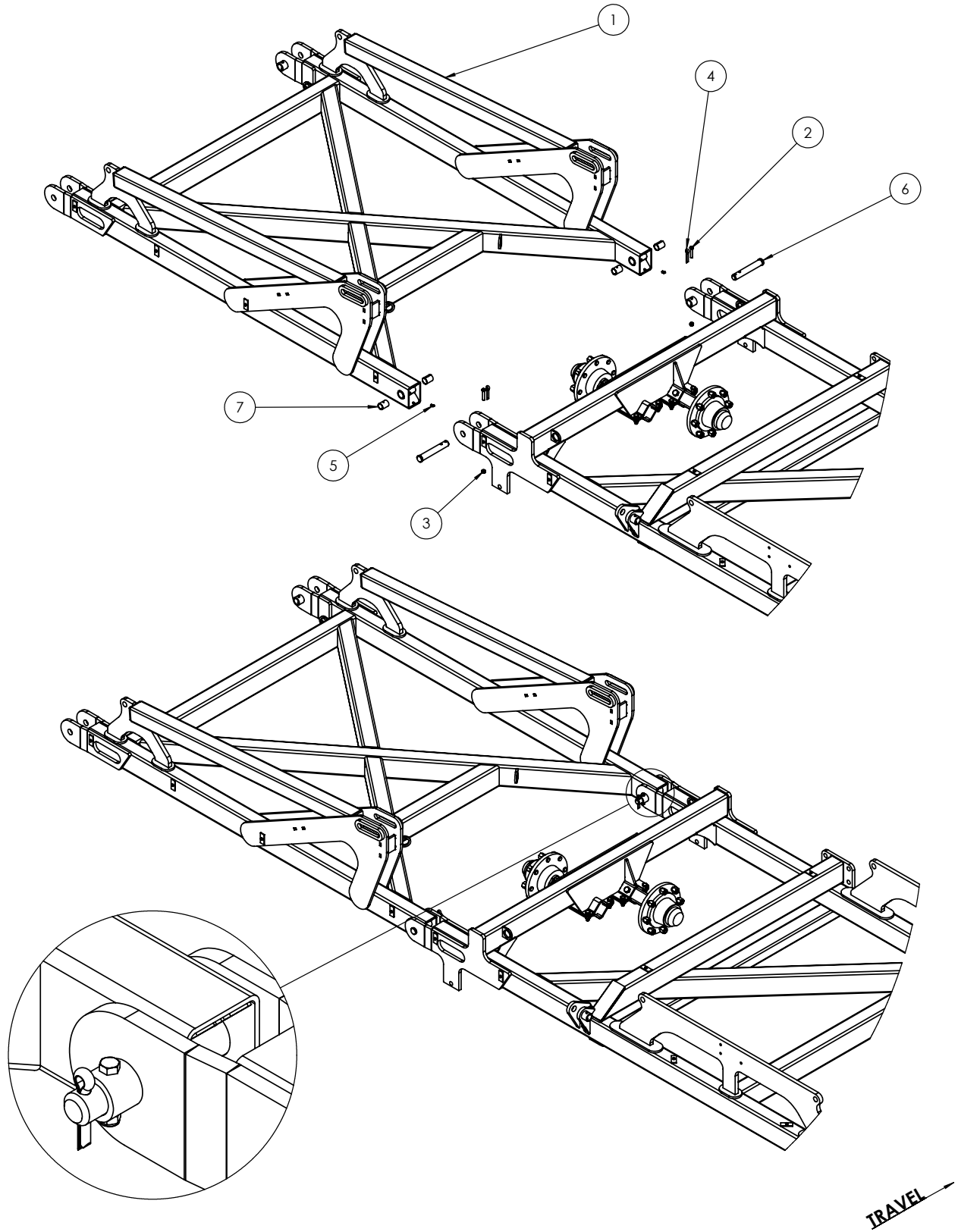

ITEM NO.	PART NUMBER	DESCRIPTION	Qty
1	0860CT-06	60CT RH Outer Wing Frame	1
2	0801-10-08-235	PCH Wing Pivot Pin	2
3	0211-1265	M12 x 65 8.8 zp Bolt	2
4	0221-NYL12	M12 Nyloc Nut	2
5	0261-PINC1363	Cotter Pin M13 x 63	2
6	0181-GN1-845	Grease Nipple 1/8" BSP 45 Deg	2
7	0113-MB 3550DX	35 ID x 50mm DX Bush	4

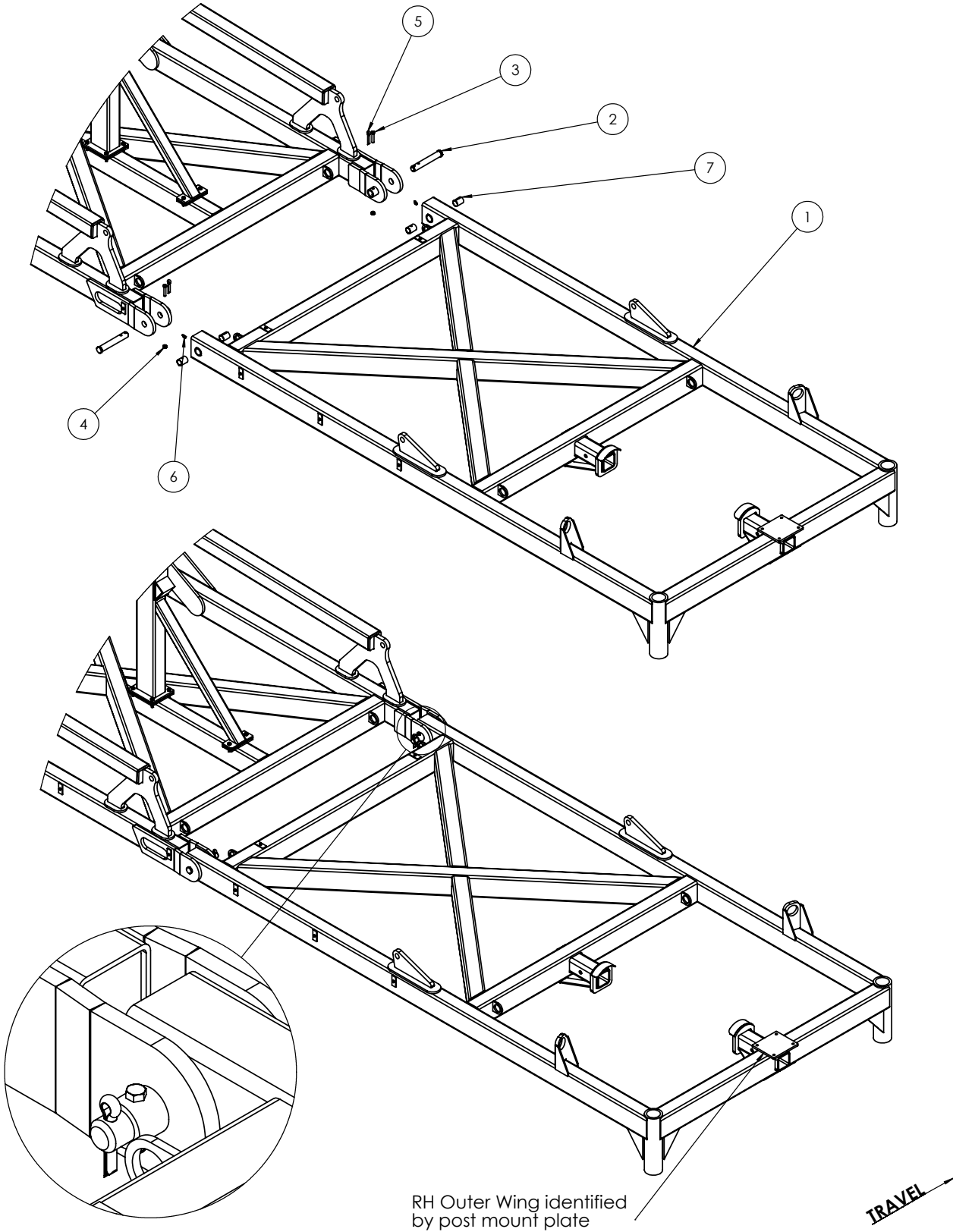

ITEM NO.	PART NUMBER	DESCRIPTION	Qty
1	0860CT-06P	60CT Outer Wing Post	1
2	0211-1250	M12 x 50 8.8 zp Bolt	4
3	0221-NYL12	M12 Nyloc Nut	4
4	0733-90	90 Series Stub Axle (Stub and Hub Complete)	2
5	0211-20130	M20 x 130 8.8 zp Bolt	2
6	0221-NYL20	M20 Nyloc Nut	2

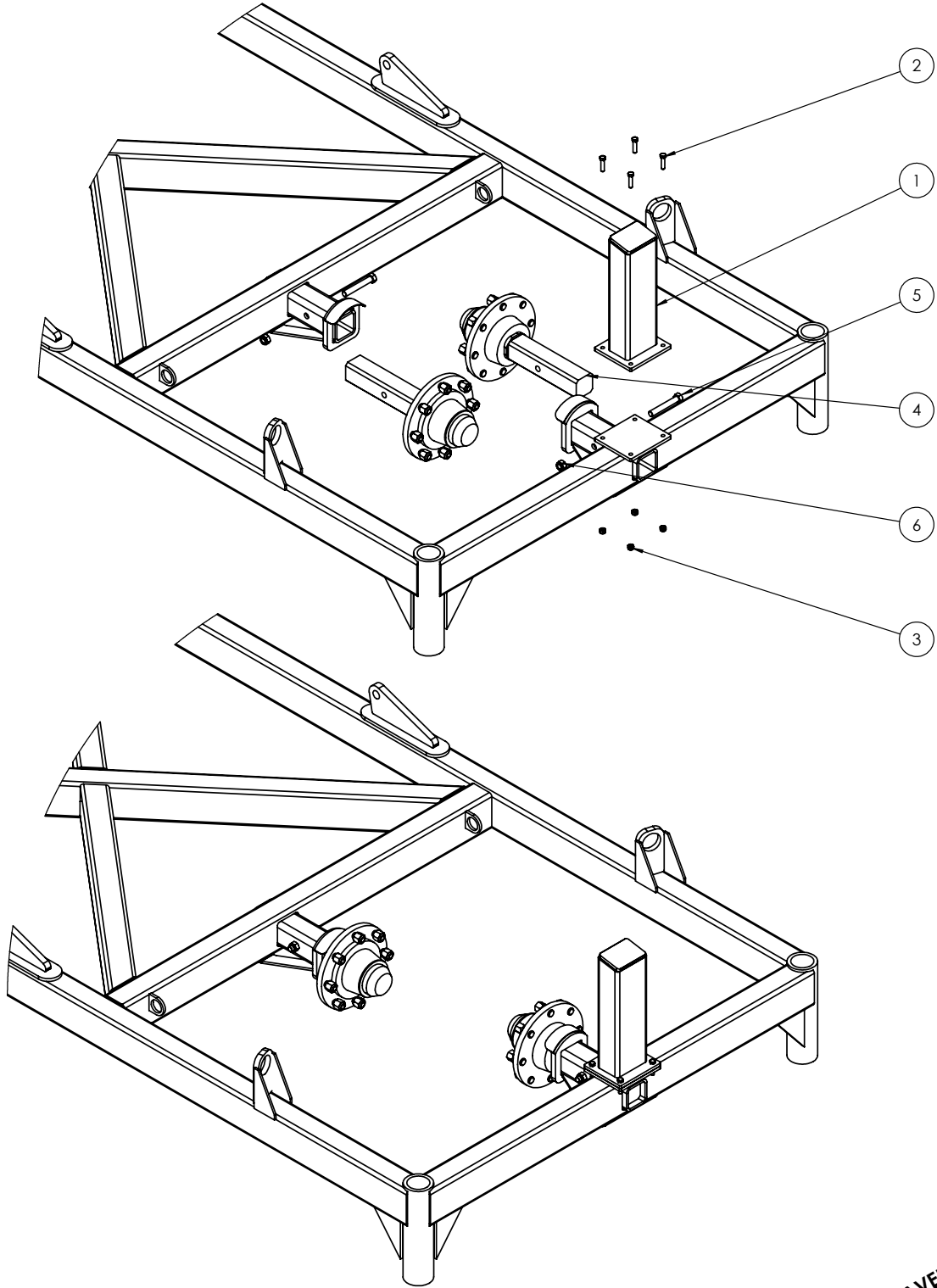

ITEM NO.	PART NUMBER	DESCRIPTION	Qty
1	0860CT-07	60CT LH Outer Wing Frame	1
2	0181-GN1-845	Grease Nipple 1/8" BSP 45 Deg	2
3	0113-MB 3550DX	35 ID x 50mm DX Bush	4
4	0211-1265	M12 x 65 8.8 zp Bolt	2
5	0221-NYL12	M12 Nyloc Nut	2
6	0261-PINC1363	Cotter Pin M13 x 63	2
7	0801-10-08-235	PCH Wing Pivot Pin	2

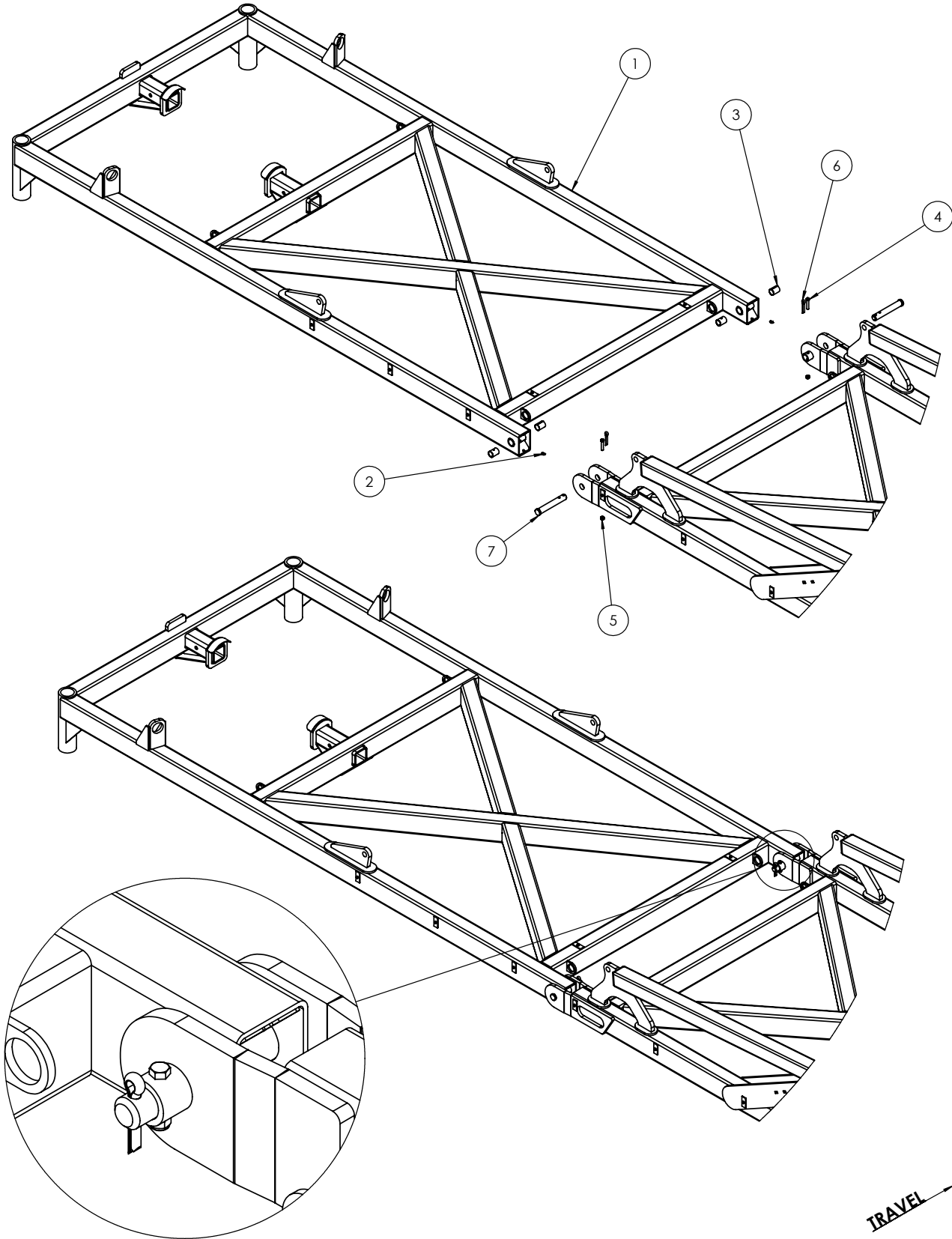

ITEM NO.	PART NUMBER	DESCRIPTION	Qty
1	0733-90	90 Series Stub Axle (Stub and Hub Complete)	2
2	0211-20130	M20 x 130 8.8 zp Bolt	2
3	0221-NYL20	M20 Nyloc Nut	2

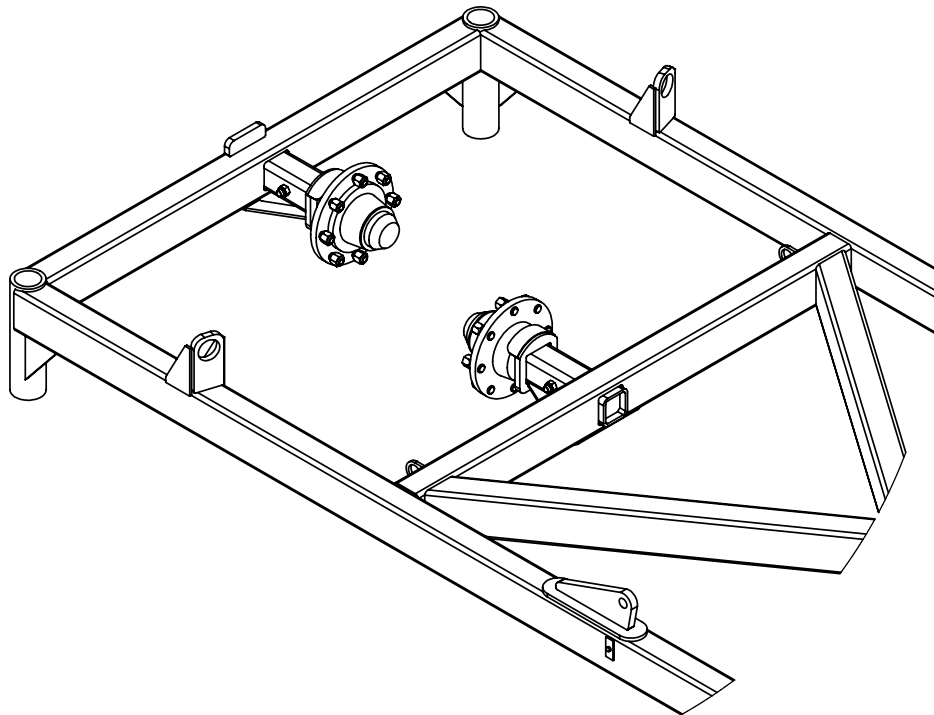
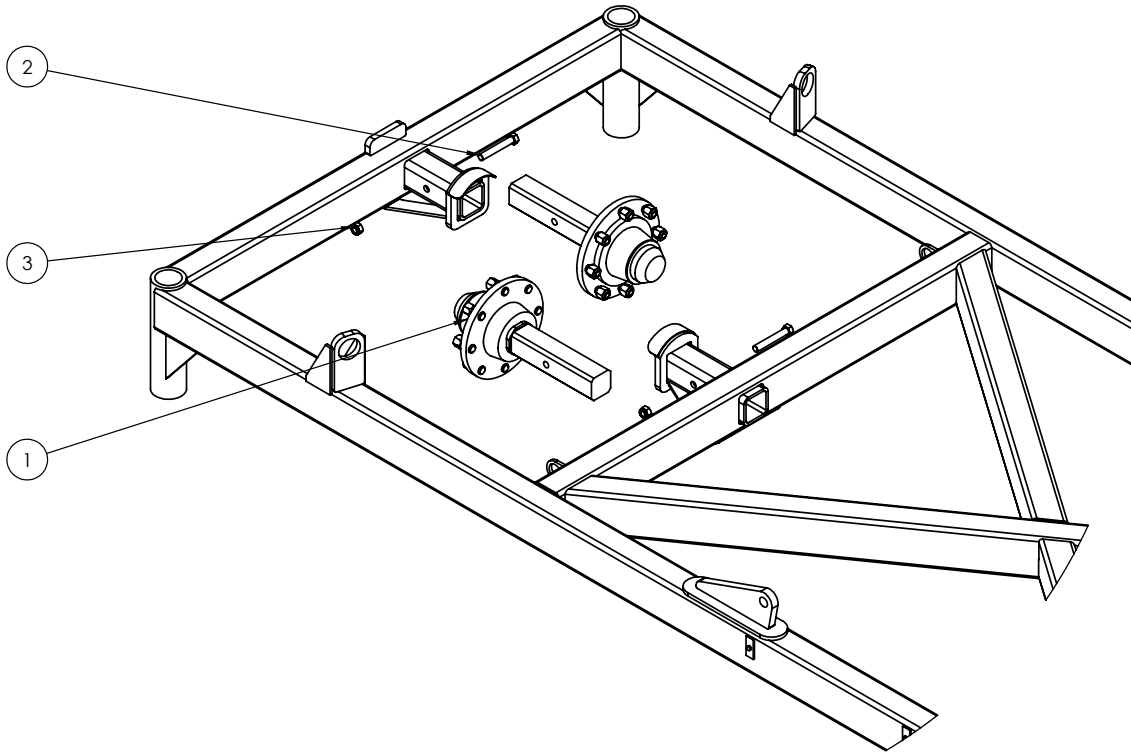

TRAVEL →

ITEM NO.	PART NUMBER	DESCRIPTION	Qty
1	0311-2956	Hyd Cylinder 5" x 36"	4
2	0801-44102956-2	Cylinder Pin 1 1/4" x 116mm	4
3	0801-44102956-1	Cylinder Pin 1 1/4" x 230mm 4140	4
4	0801-KE012	S Locking Pin Clip 5mm	12
5	0232-F11-4	Washer Flat 1 1/4"	12

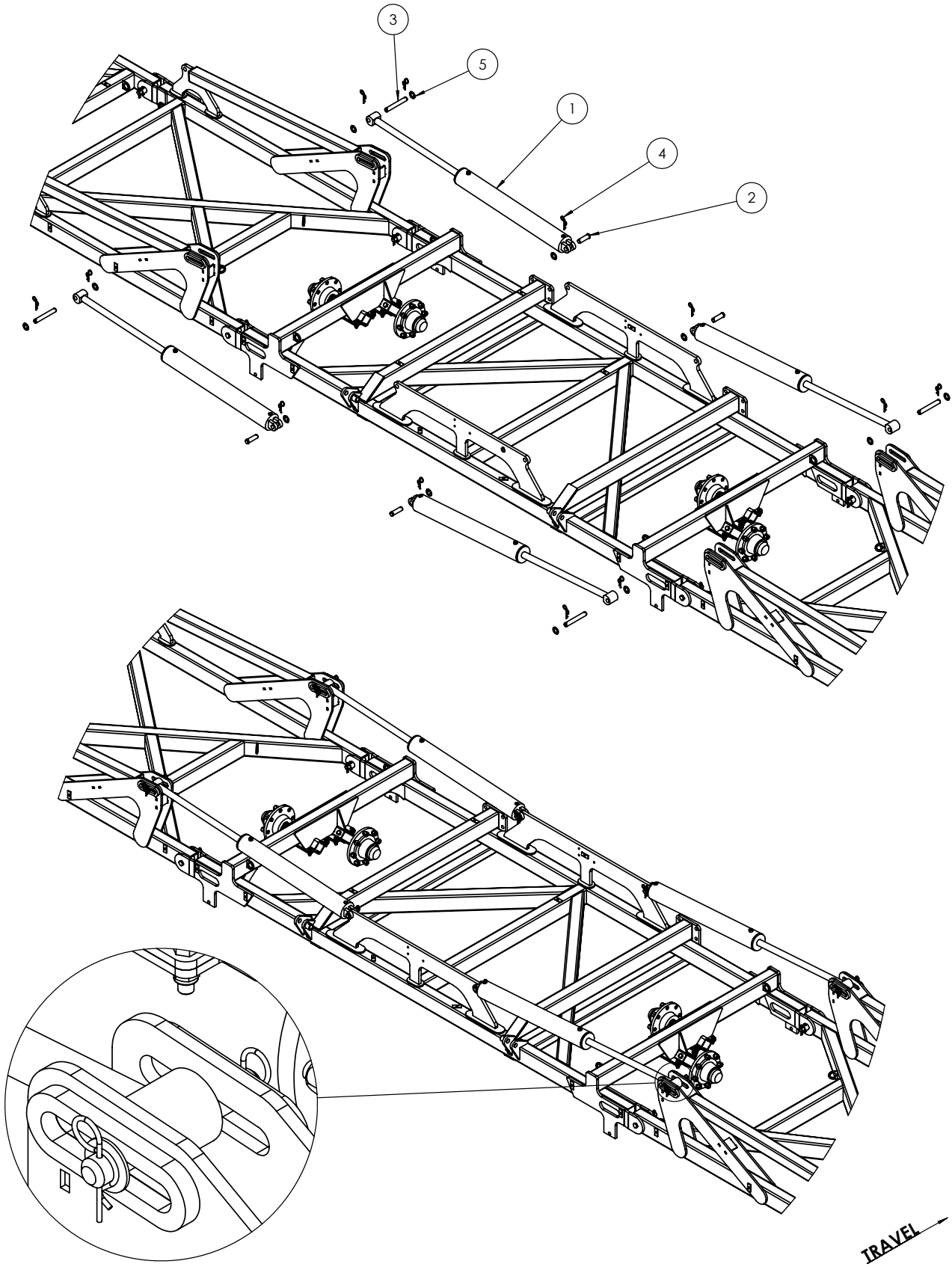

ITEM NO.	PART NUMBER	DESCRIPTION	Qty
1	0311-6896	Hyd Cylinder 3.5" x 32" + 4" Stop Tube	2
2	0801-44103786	Cylinder Pin 1 1/4" x 94mm	4
3	0232-F11-4	Washer Flat 1 1/4"	4
4	0801-KE012	S Locking Pin Clip 5mm	4

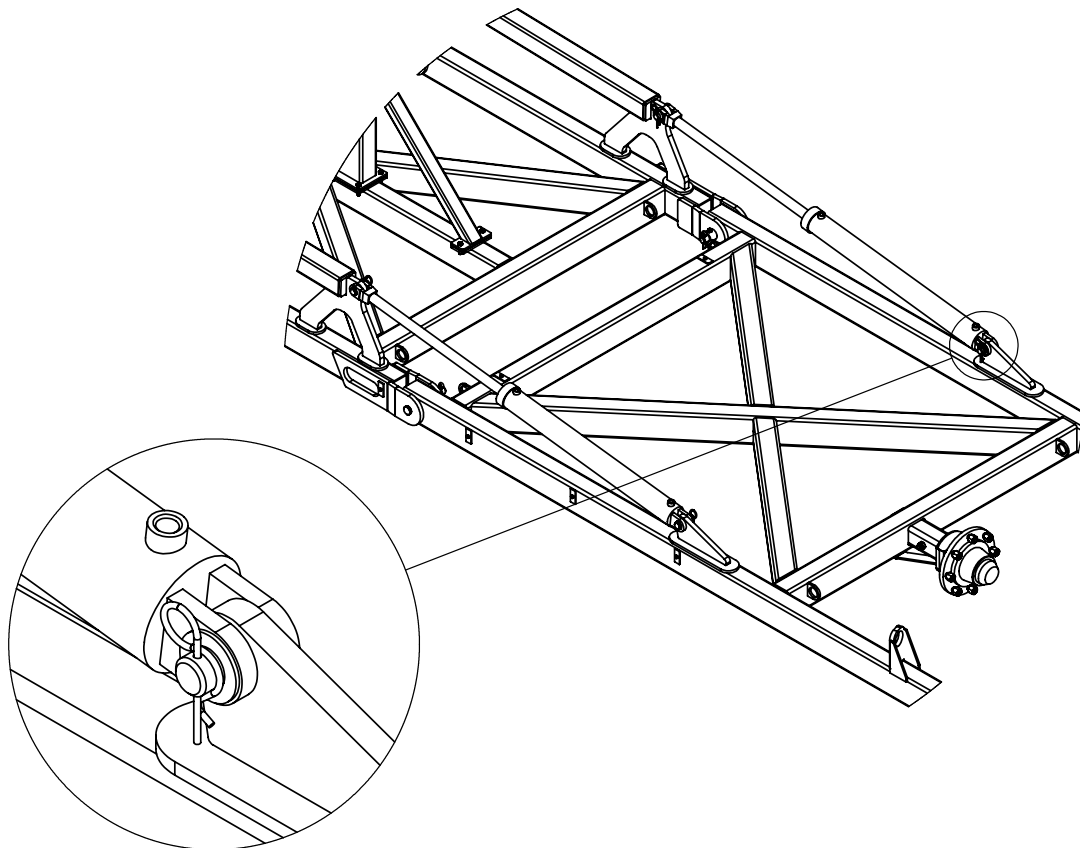
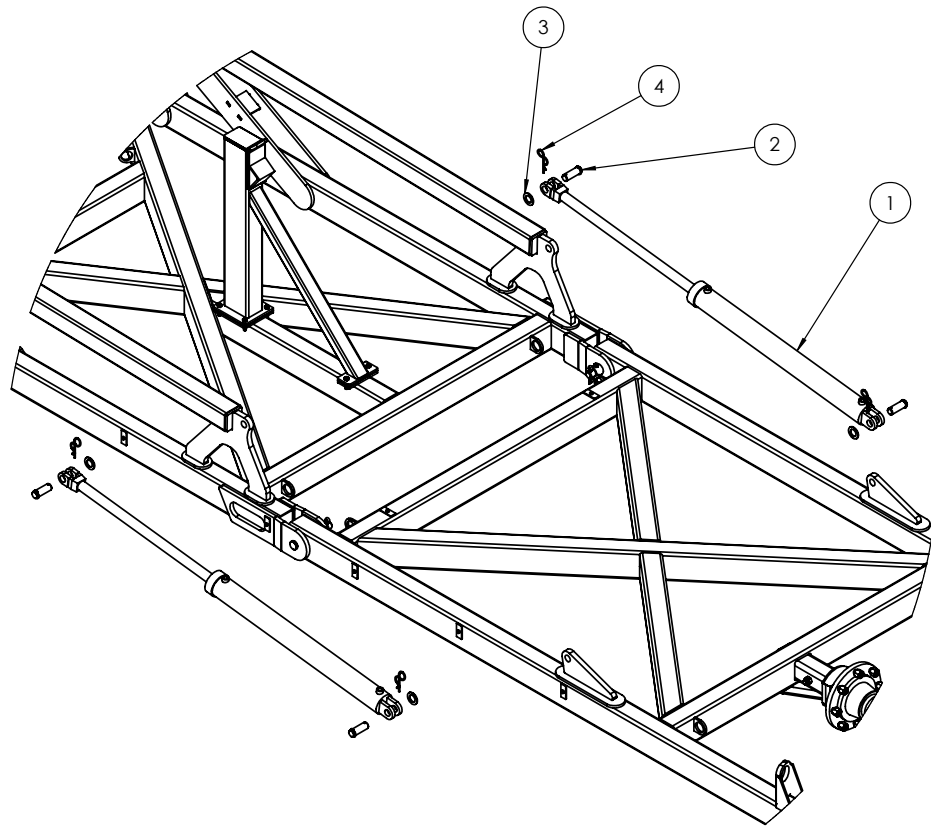

TRAVEL →

ITEM NO.	PART NUMBER	DESCRIPTION	Qty
1	0311-6896	Hyd Cylinder 3.5" x 32" + 4" Stop Tube	2
2	0801-44103786	Cylinder Pin 1 1/4" x 94mm	4
3	0232-F11-4	Washer Flat 1 1/4"	4
4	0801-KE012	S Locking Pin Clip 5mm	4

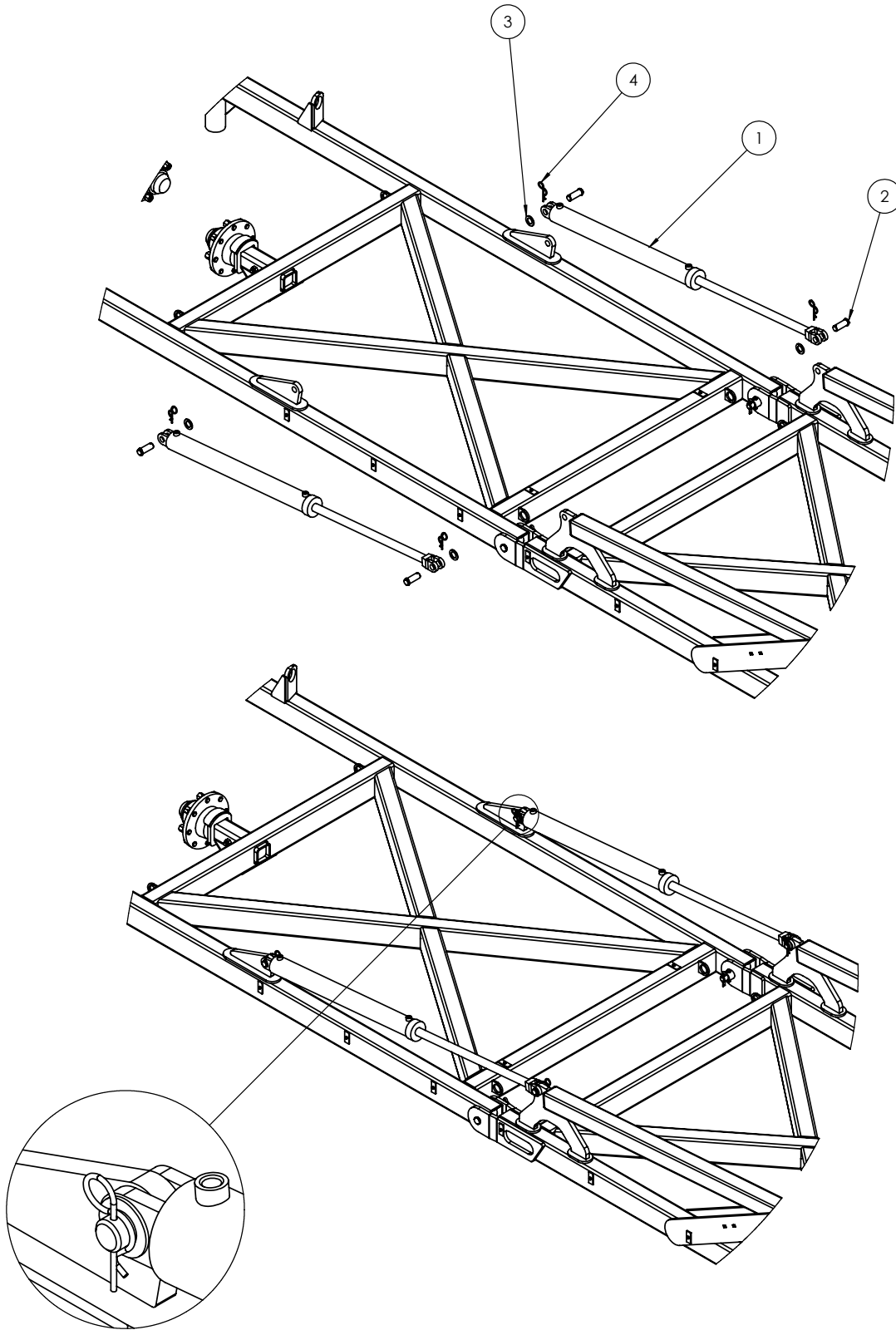

TRAVEL

ITEM NO.	PART NUMBER	DESCRIPTION	Qty
1	0860CT-02F	60CT Front A-Frame Front Section	1
2	0860CT-02L	60CT Front A-Frame LH Beam	1
3	0860CT-02R	60CT Front A-Frame RH Beam	1
4	0860CT-02B	60CT Front A-Frame Brace	1
5	M24 x 75 8.8 zp Bolt		16
6	0221-NYL24	M24 Nyloc Nut	16
7	0211-1650	M16 x 50 8.8 zp Bolt	8
8	0221-NYL16	M16 Nyloc Nut	8

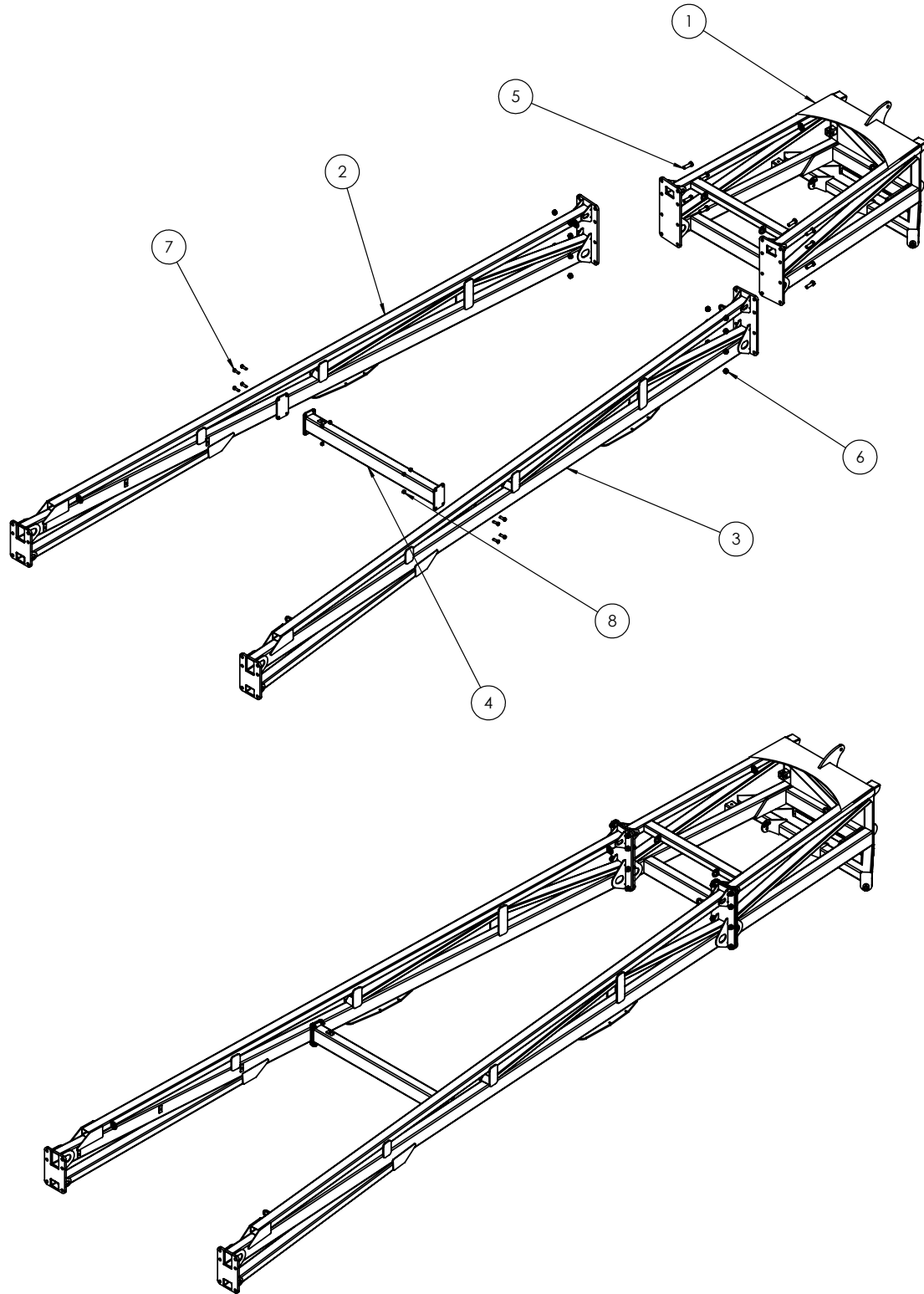

TRAVEL →

ITEM NO.	PART NUMBER	DESCRIPTION	Qty
1	0810-28-60	50 & 60' Front Module	1

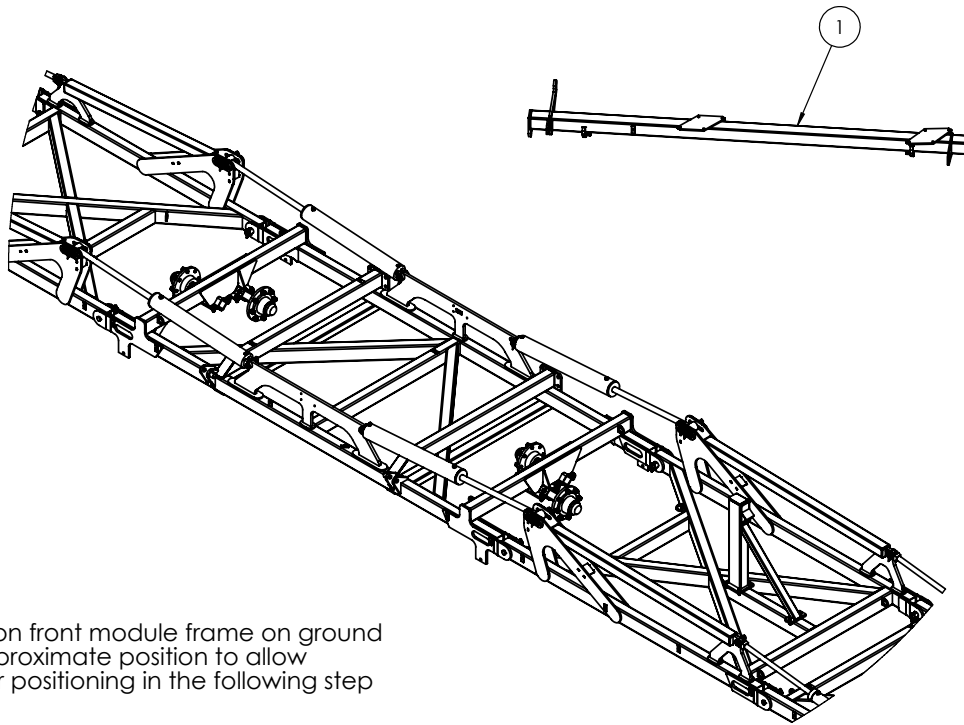

Position front module frame on ground in approximate position to allow easier positioning in the following step

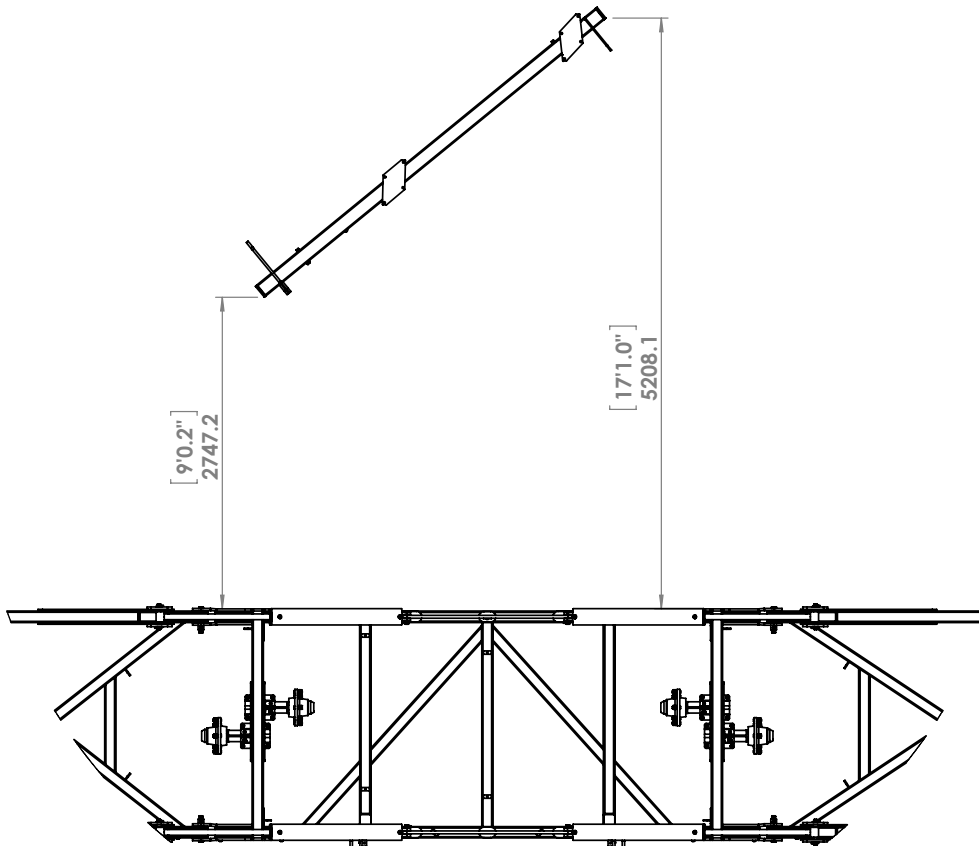

TRAVEL

ITEM NO.	PART NUMBER	DESCRIPTION	Qty
1	0211-1650	M16 x 50 8.8 zp Bolt	8
2	0221-NYL16	M16 Nyloc Nut	8
3	0211-2475	M24 x 75 8.8 zp Bolt	12
4	0221-NYL24	M24 Nyloc Nut	12

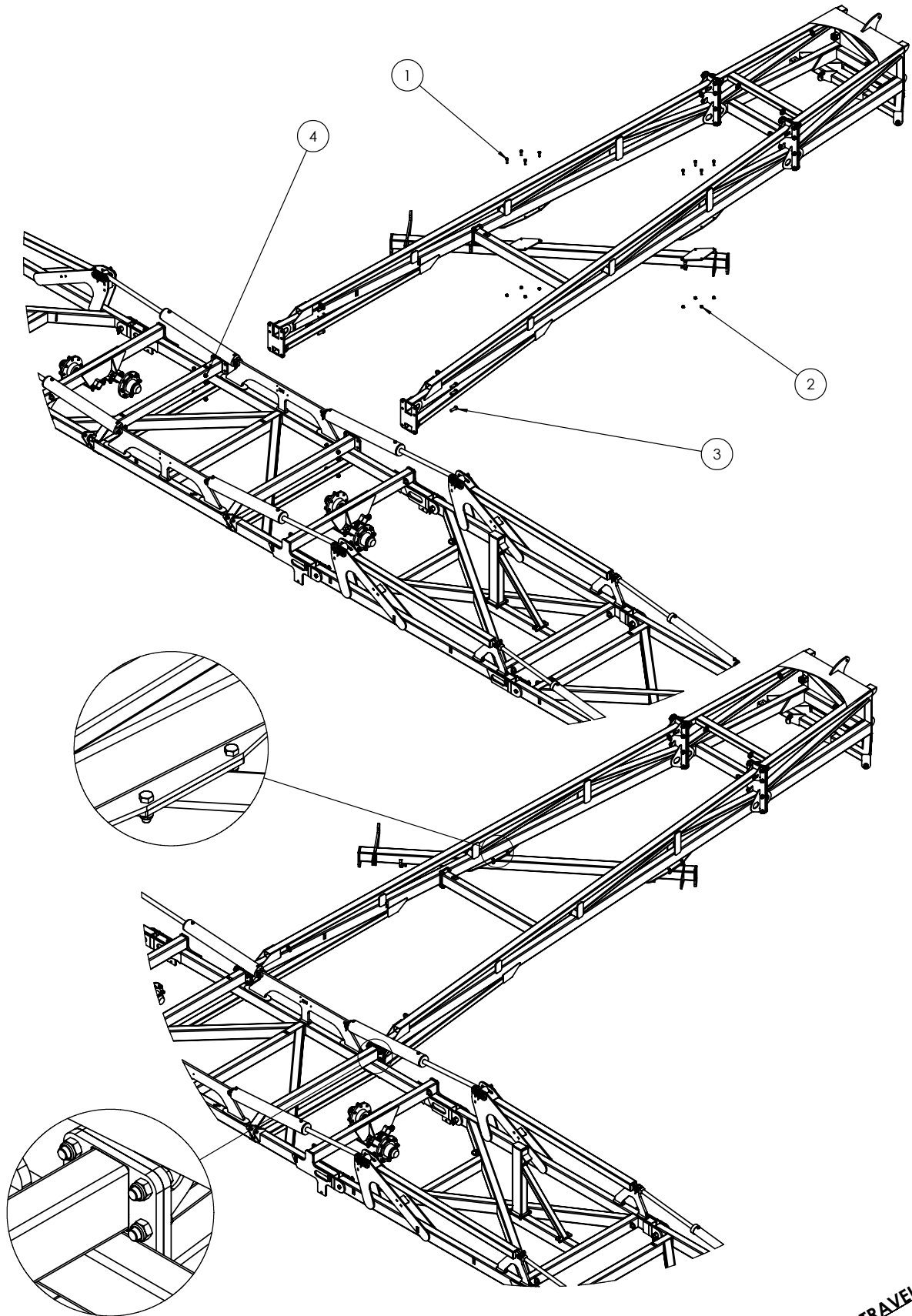

ITEM NO.	PART NUMBER	DESCRIPTION	Qty
1	0751-15.5-80-248STR	15.5/80/24 Tyre on 8 Stud Rim	8

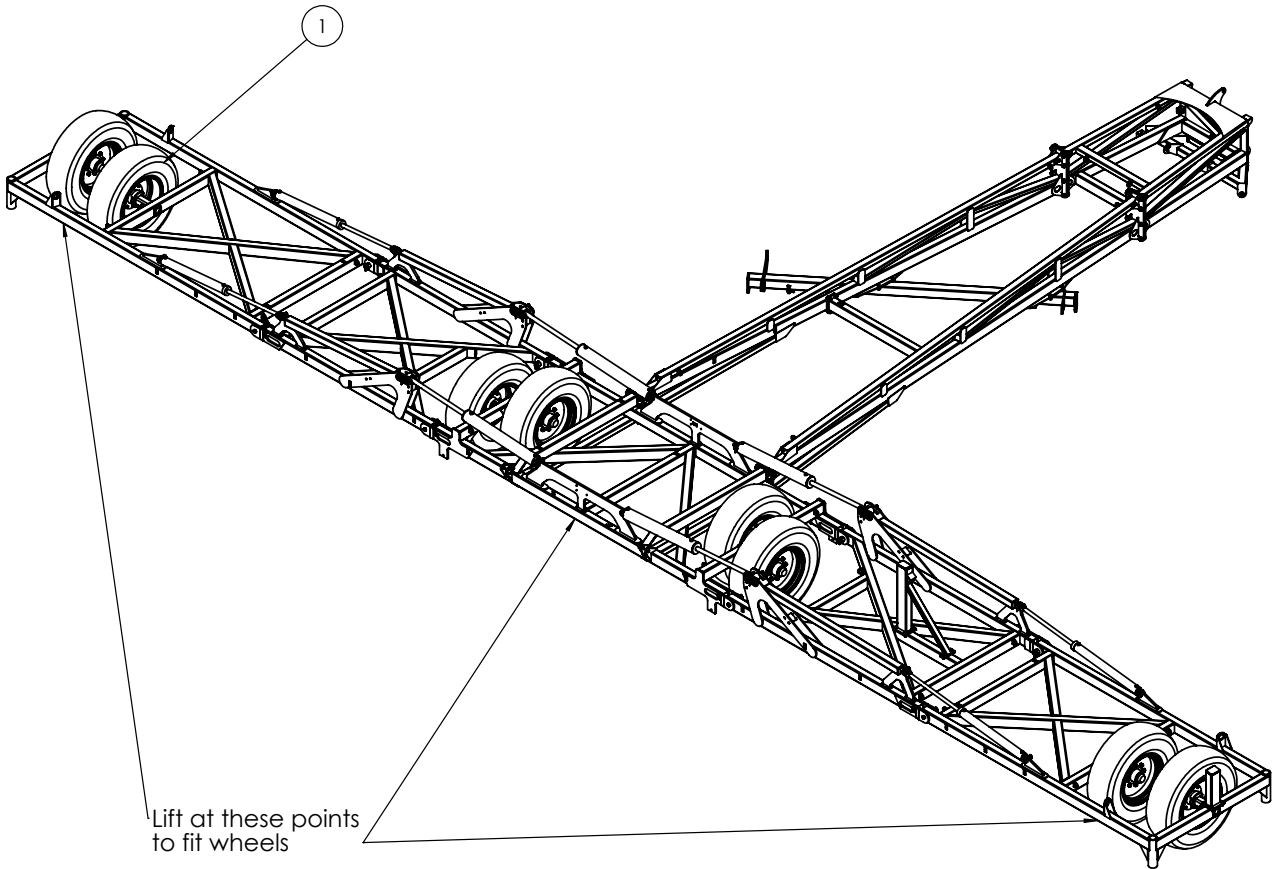

TRAVEL →

ITEM NO.	PART NUMBER	DESCRIPTION	Qty
1	0810-08	Drawbar Frame	1
2	0810-37A	Heavy Duty Jack Assembly	1
3	0801-10-13-970	Drawbar Pivot Pin	1
4	0311-6357	Hyd Cylinder 4 x 12 Extended	1
5	0211-1265	M12 x 65 8.8 zp Bolt	1
6	0221-NYL12	M12 Nyloc Nut	1
7	0261-PINC1363	Cotter Pin M13 x 63	1
8	0801-44082938	Clevis Pin 1" x 75mm	2
9	0511-RCLIP4	R Clip 4mm	2

**PLEASE REFER TO
ASSEMBLY UPDATE 019
IN THE BACK OF THE
MANUAL**

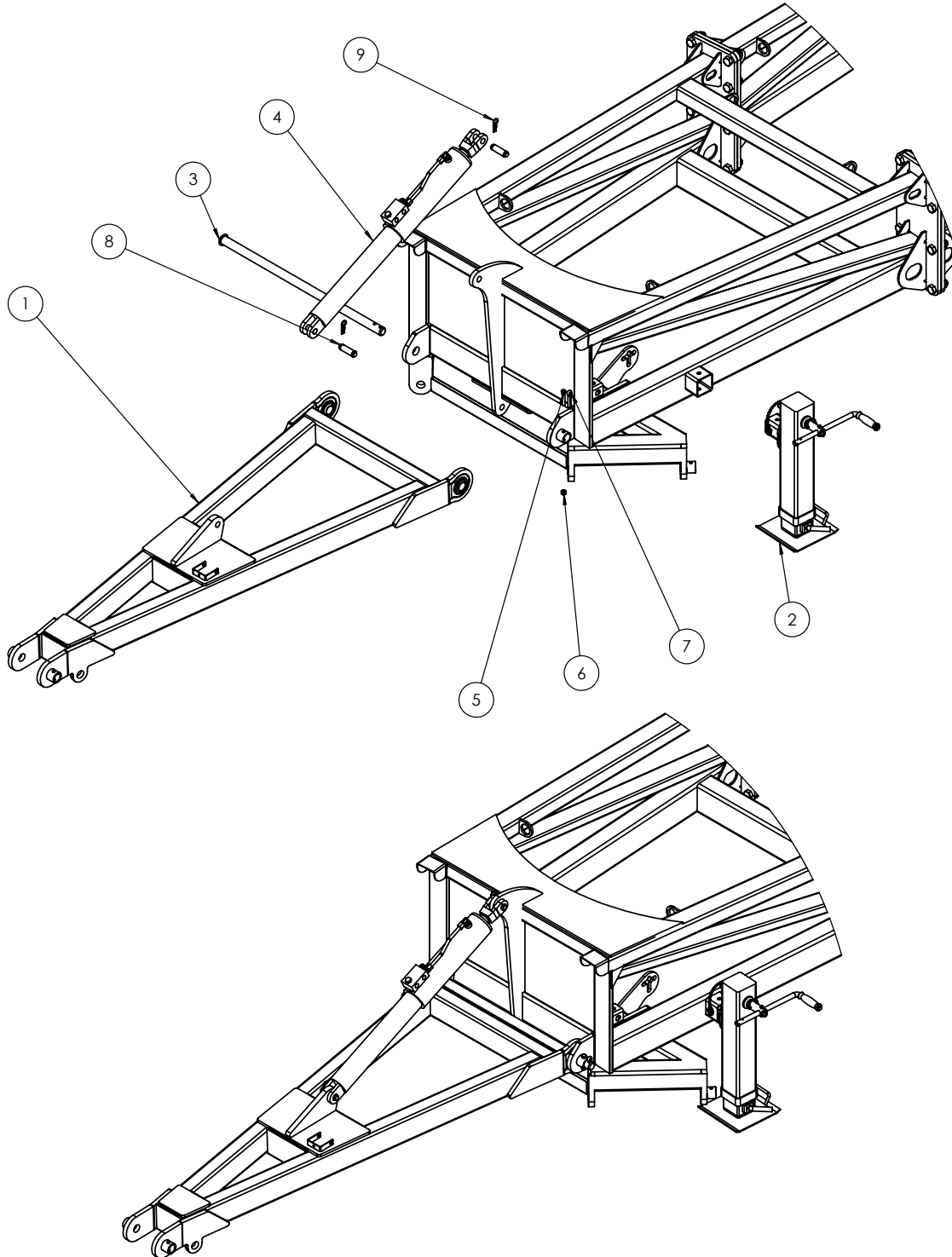

TRAVEL

ITEM NO.	PART NUMBER	DESCRIPTION	Qty
1	0810-09A	Tow Hitch Assembly	1
2	0810-22	Parallel Arm	1
3	0810-16	Safety Chain Assembly	1
4	0801-10-06	Tow Hitch Pivot Pin	1
5	0211-1265	M12 x 65 8.8 zp Bolt	2
6	0221-NYL12	M12 Nyloc Nut	2
7	0801-KE0307-1	Clevis Pin 25mm x 75mm	2
8	0261-PINC550	Cotter Pin M5 x 50	2
9	0231-F24	M24 zp Flat Washer	2

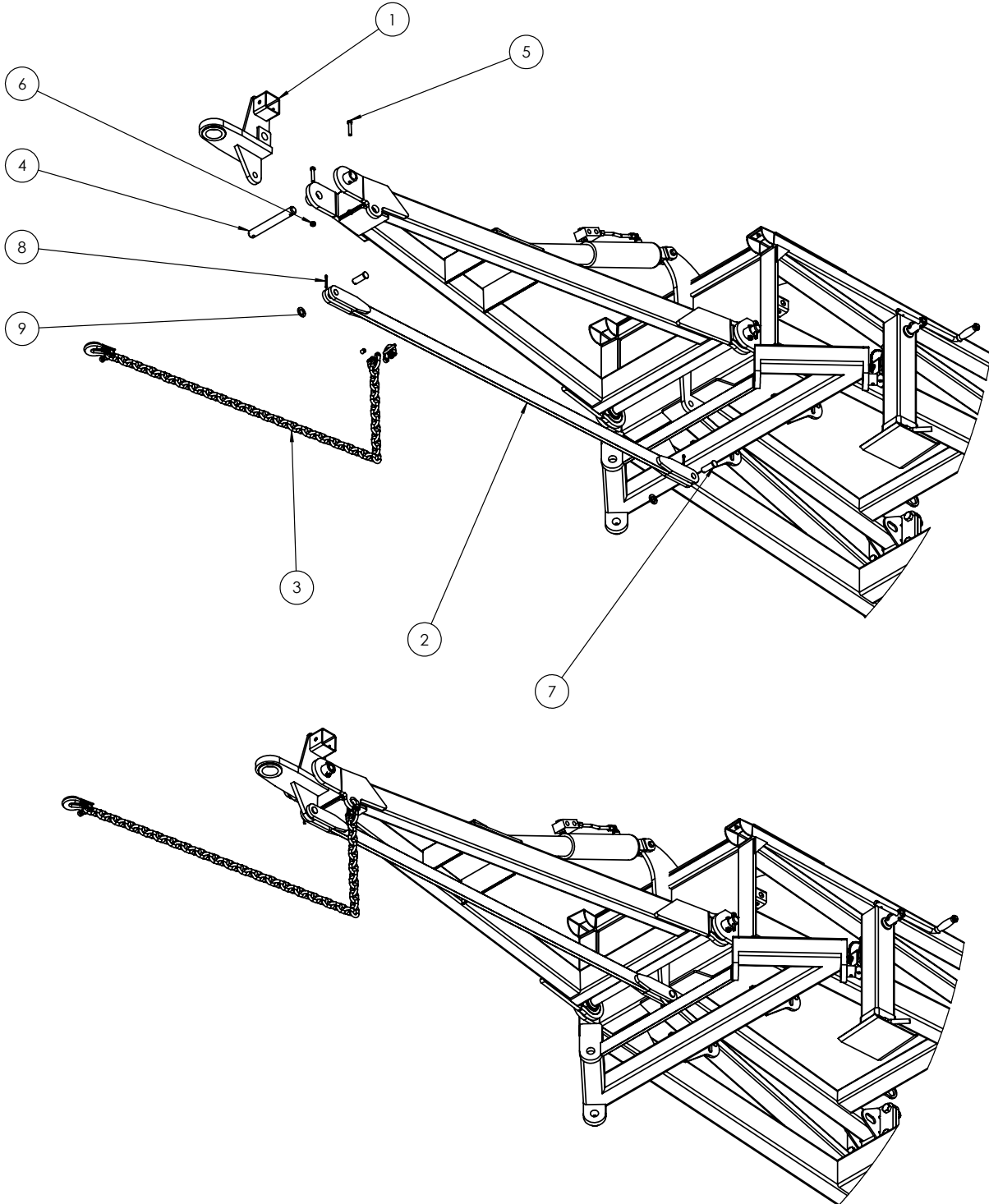

TRAVEL

ITEM NO.	PART NUMBER	DESCRIPTION	Qty
1	0810-151	Hose Post	1
2	0416-11750B	Electrical Plug Keeper	1
3	0211-M620MZPHTF	M6 x 20 Trilobe self tapping ScREW	2
4	0211-820	M8 x 20 8.8 zp bolt	3
5	0221-NYL8	M8 Nyloc Nut	3

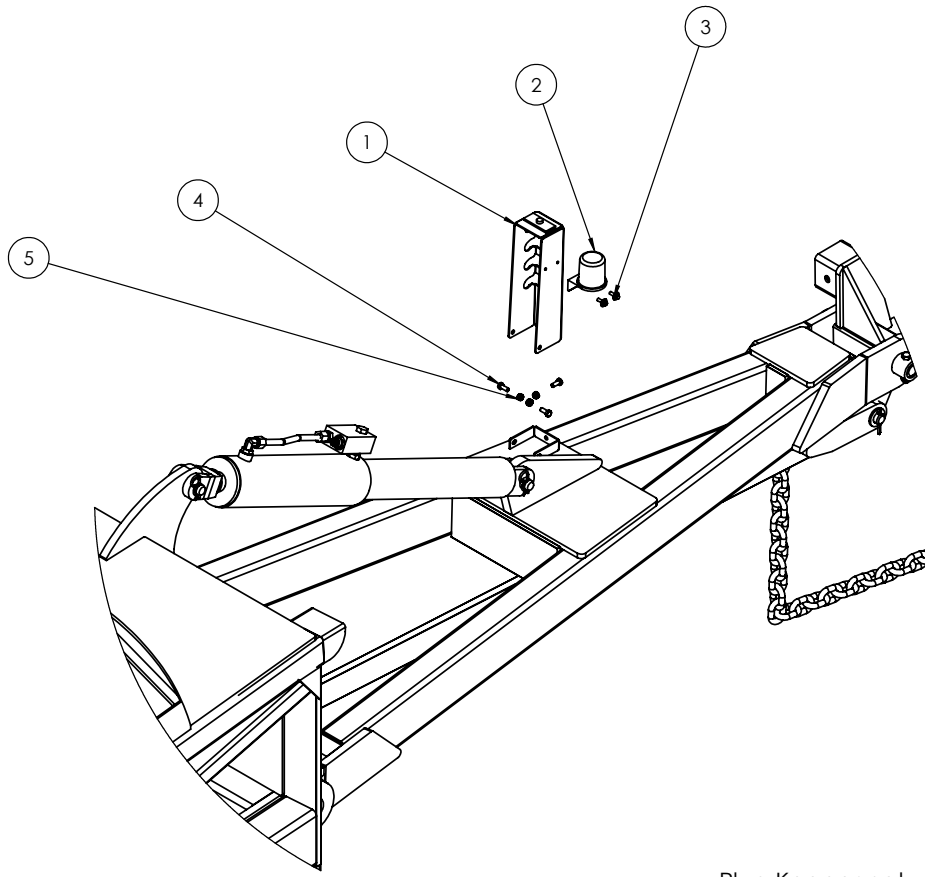

Plug Keeper not used on domestic machines

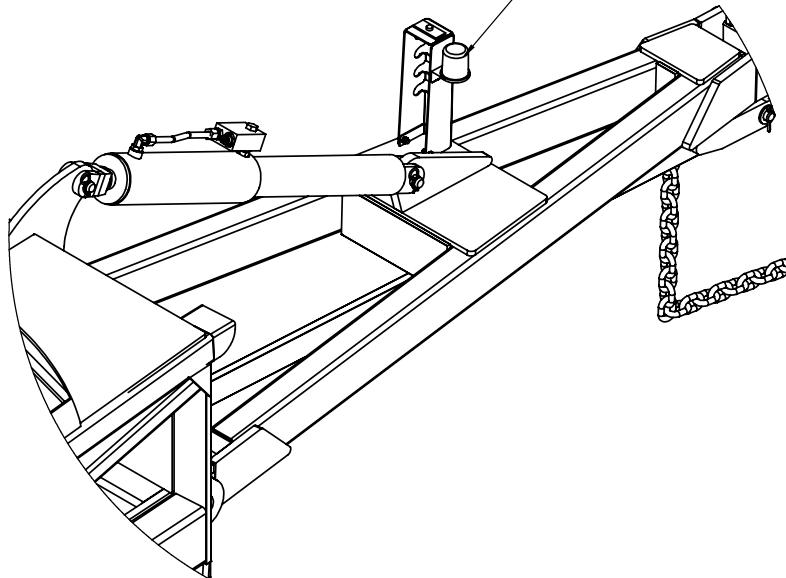

TRAVEL

ITEM NO.	PART NUMBER	DESCRIPTION	Qty
1	0810-29-60	50 & 60' Rear Module	1

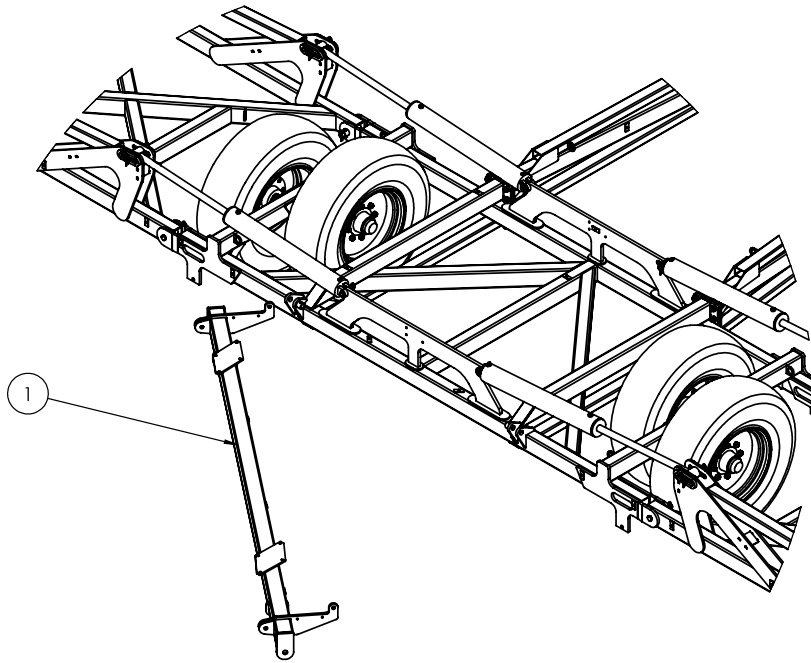

Position rear module frame on ground in approximate position to allow easier positioning in the following step

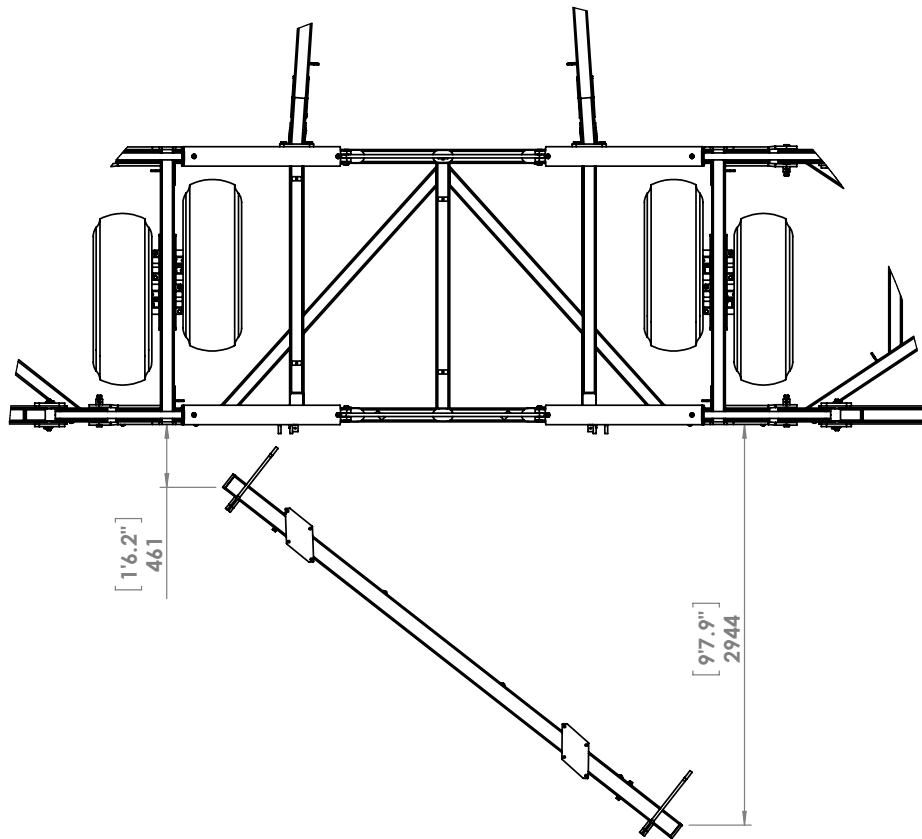

TRAVEL

ITEM NO.	PART NUMBER	DESCRIPTION	Qty
1	0860CT-03	60CT Rear A-Frame	1
2	0801-10-08-175	Tail Frame Pivot pin	2
3	0211-1265	M12 x 65 8.8 zp Bolt	2
4	0221-NYL12	M12 Nyloc Nut	2
5	0261-PINC1363	Cotter Pin M13 x 63	2
6	0211-1650	M16 x 50 8.8 zp Bolt	8
7	0221-NYL16	M16 Nyloc Nut	8

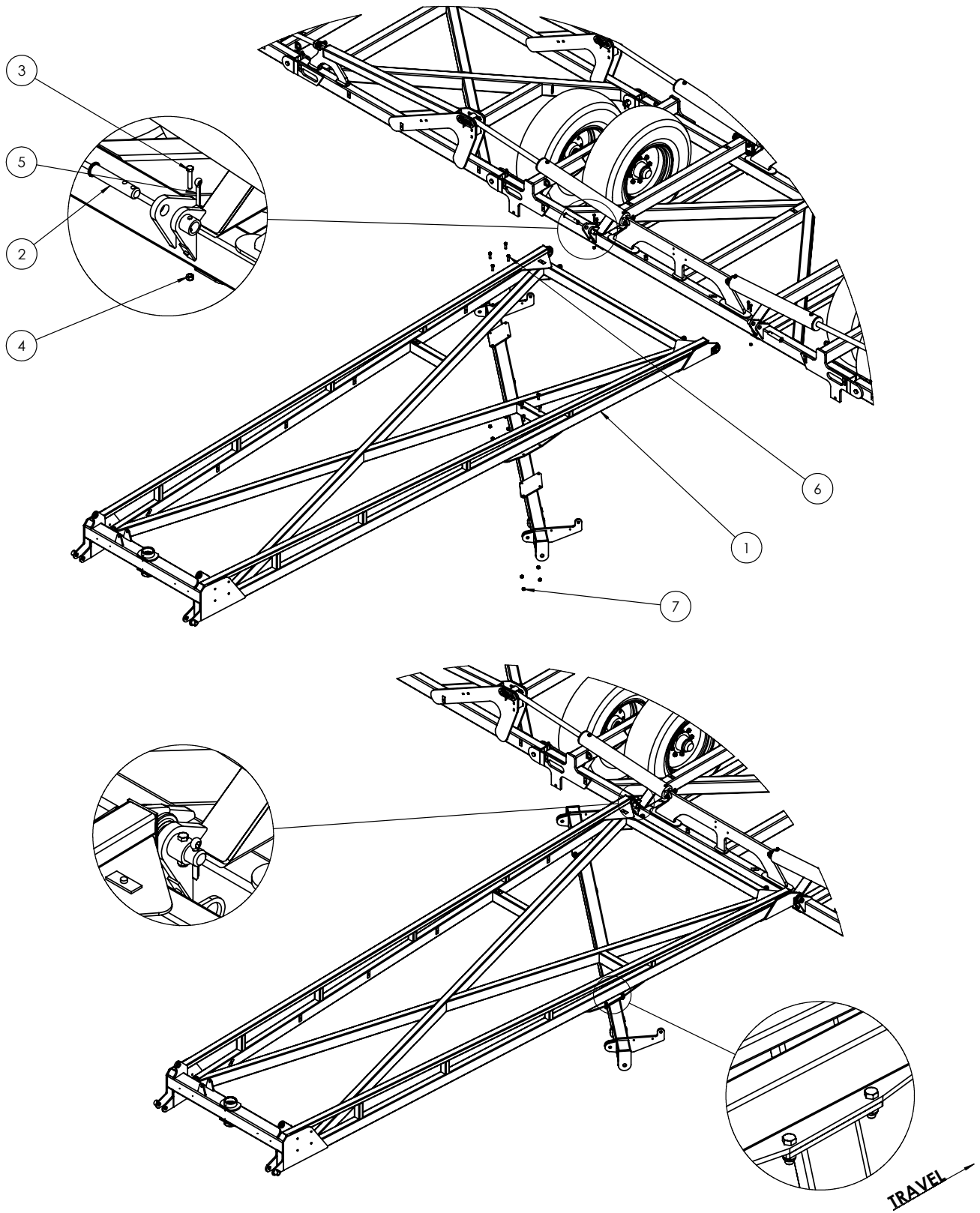

ITEM NO.	PART NUMBER	DESCRIPTION	Qty
1	0810-11-70	70mm Jockey Wheel	1
2	0113-GE70DO-2RS	Plain Spherical Bearing 70mm	2
3	0171-J105	Circlip Internal 105mm	2
4	0181-GN1-4	Grease Nipple 1/4" UNF	2
5	0801-KE0705-13	70mm Polymer dust cap	1
6	0810-12DISC	Jockey Wheel Brake Disc	1
7	0231-SQ12505	Washer Square M12 x 50 x 5	1
8	0231-S12	M12 zp Spring Washer	1
9	0211-1230	M12 x 30 8.8 zp Bolt	1

**PLEASE REFER TO
ASSEMBLY UPDATE 035
IN THE BACK OF THE
MANUAL**

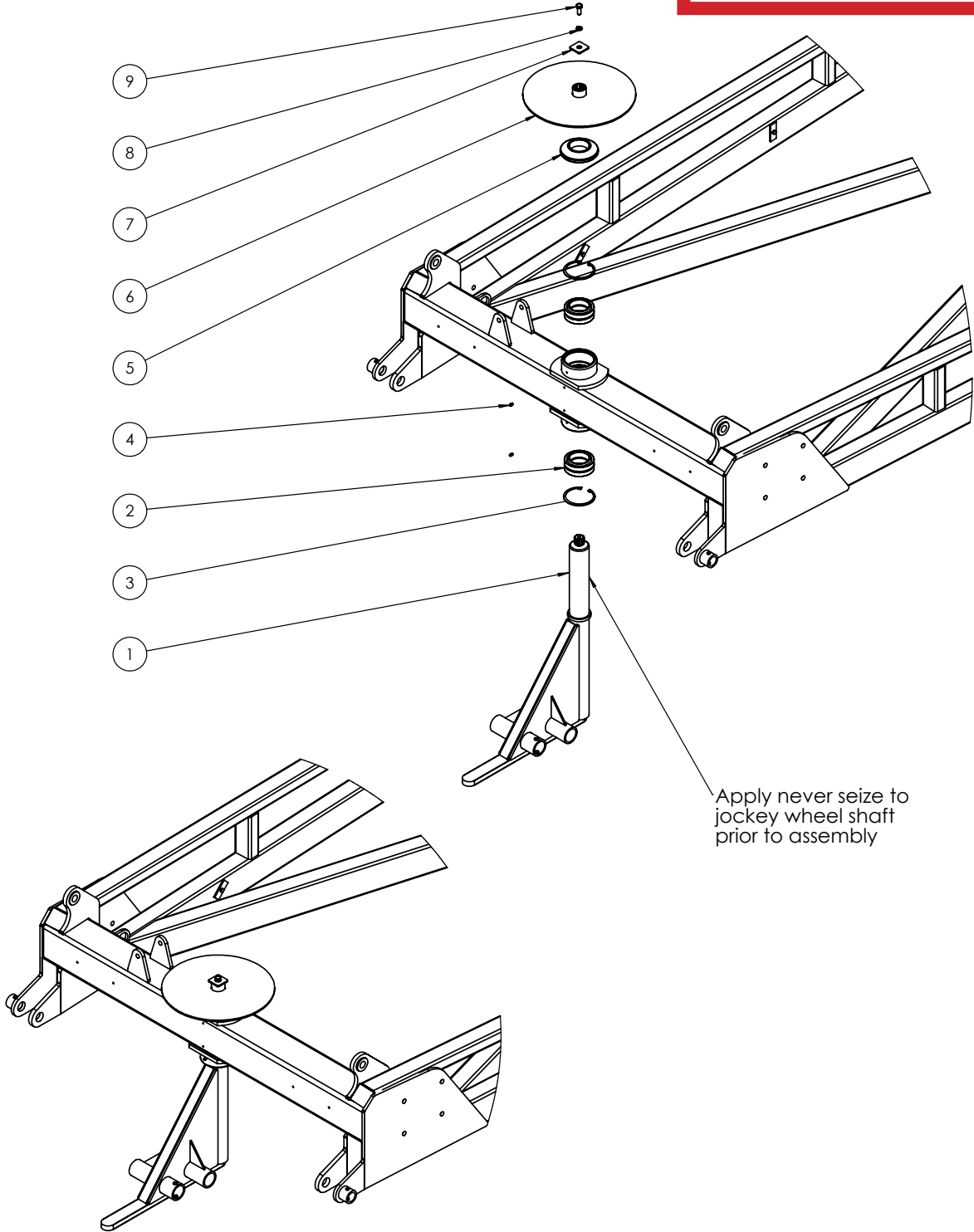

TRAVEL →

ITEM NO.	PART NUMBER	DESCRIPTION	Qty
1	0810-12CAL	Jockey Wheel Brake Calpier	1
2	0801-KE009	Brake Compression Spring	1
3	0231-SQ16505	Washer Square M16 x 50 x 5	1
4	0181-GN1-4	Grease Nipple 1/4" UNF	2
5	0211-16150	M16 x 150 8.8 zp Bolt	2
6	0221-NYL16	M16 Nyloc Nut	1

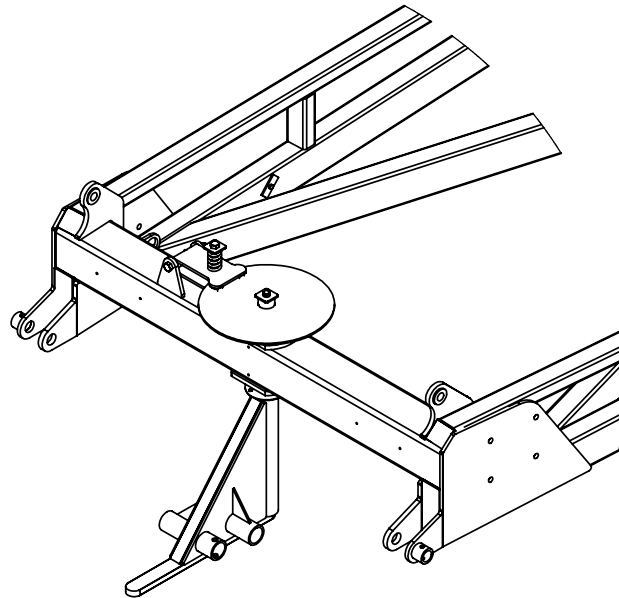
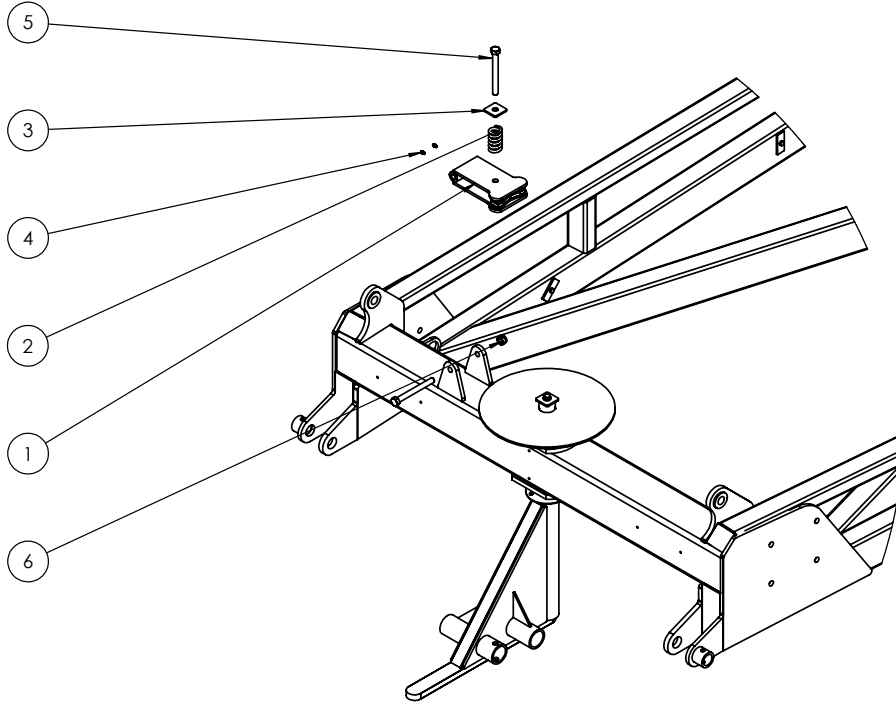

TRAVEL

ITEM NO.	PART NUMBER	DESCRIPTION	Qty
1	0733-K5083T66S	Axle 2"R 3T 6 on 6" PCD 330 OHF	2
2	0751-11L15	11L15F3 Tyre on Rim	2
3	0211-1690	M16 x 90 8.8 zp Bolt	2
4	0221-NYL16	M16 Nyloc Nut	2

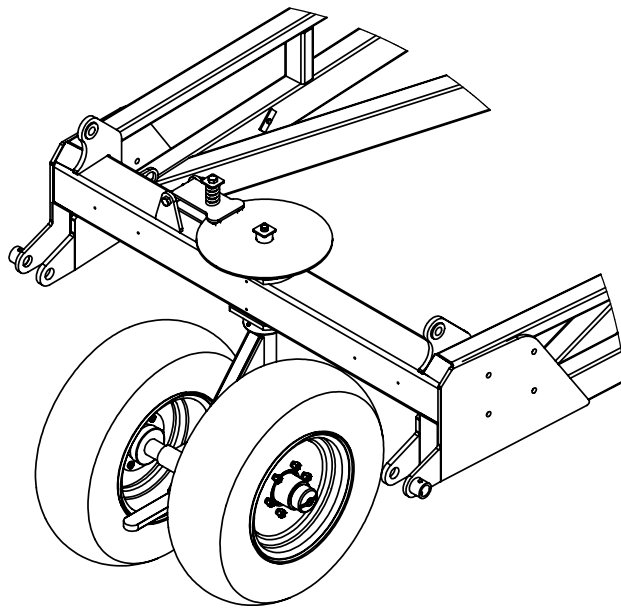
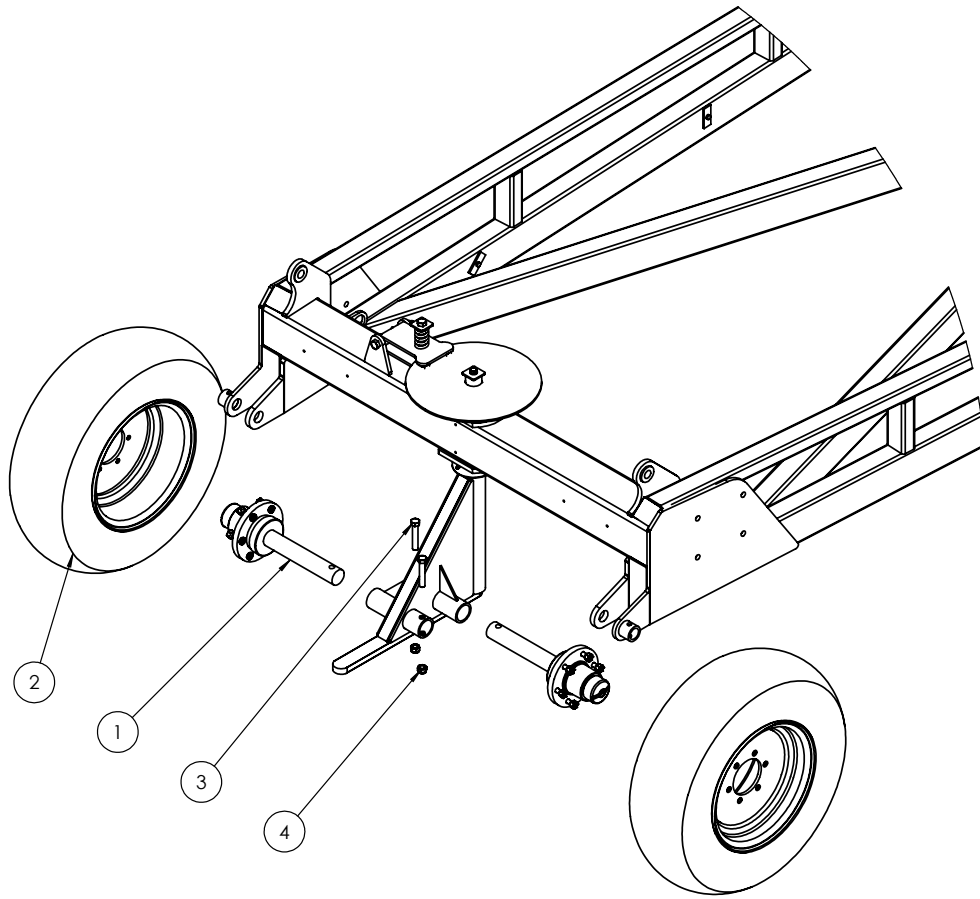

TRAVEL

ITEM NO.	PART NUMBER	DESCRIPTION	Qty
1	0810-10	Rear Tail	1
2	0801-10-08-175	Tail Frame Pivot pin	2
3	0211-1265	M12 x 65 8.8 zp Bolt	2
4	0221-NYL12	M12 Nyloc Nut	2
5	0261-PINC1363	Cotter Pin M13 x 63	2

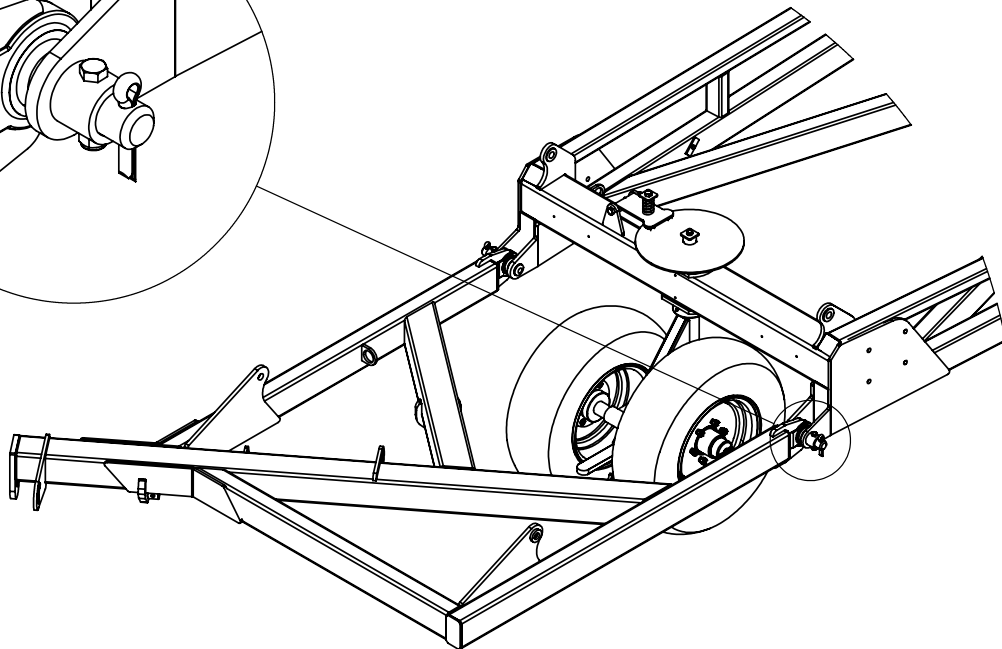
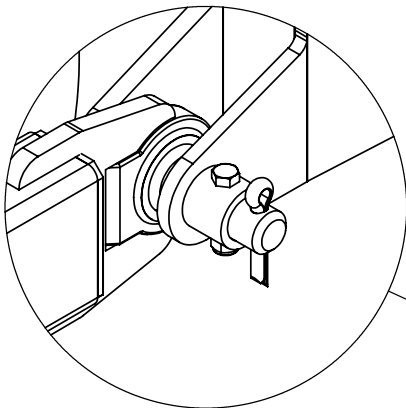
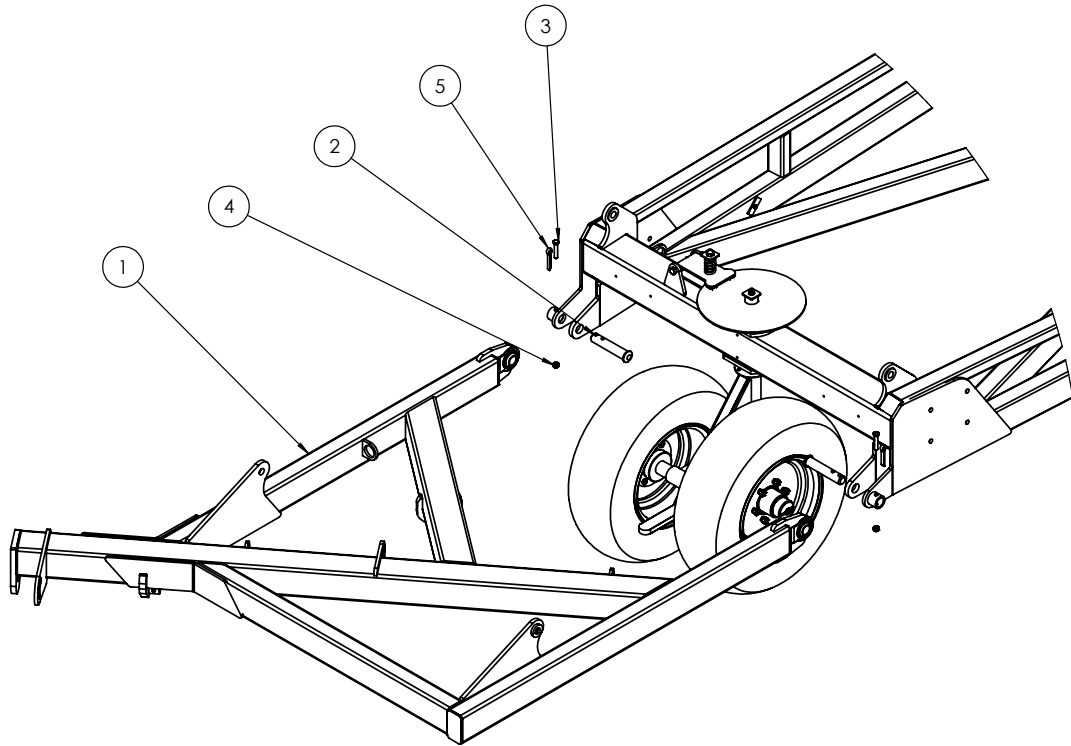

TRAVEL →

ITEM NO.	PART NUMBER	DESCRIPTION	Qty
1	0311-2958	Hyd Cylinder 3.5" x 24"	2
2	0801-44082938	Clevis Pin 1" x 75mm	4
3	0511-RCLIP4	R Clip 4mm	4

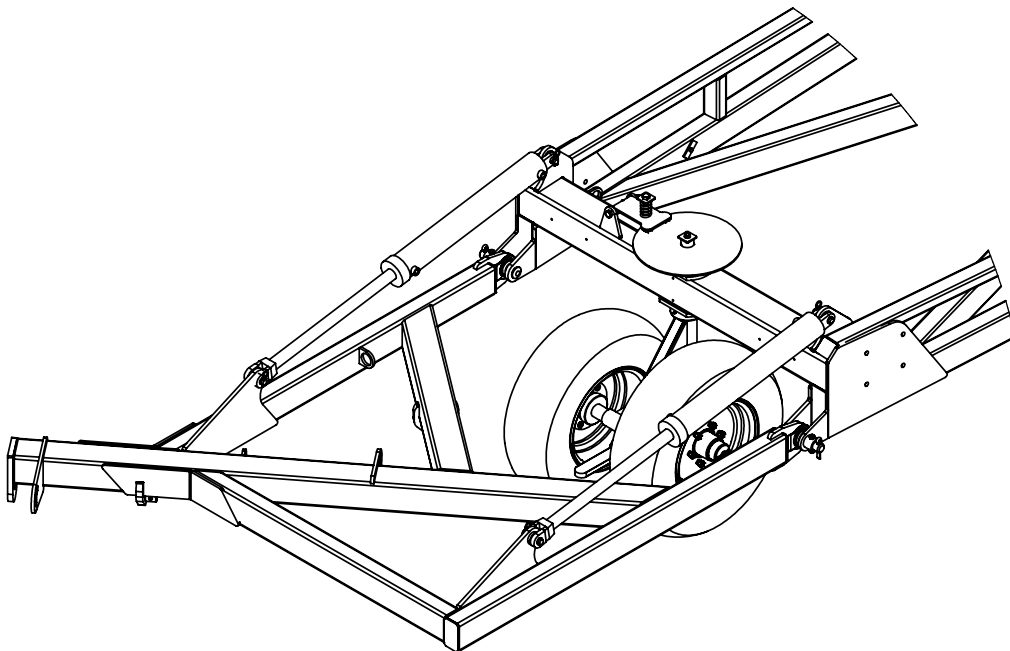
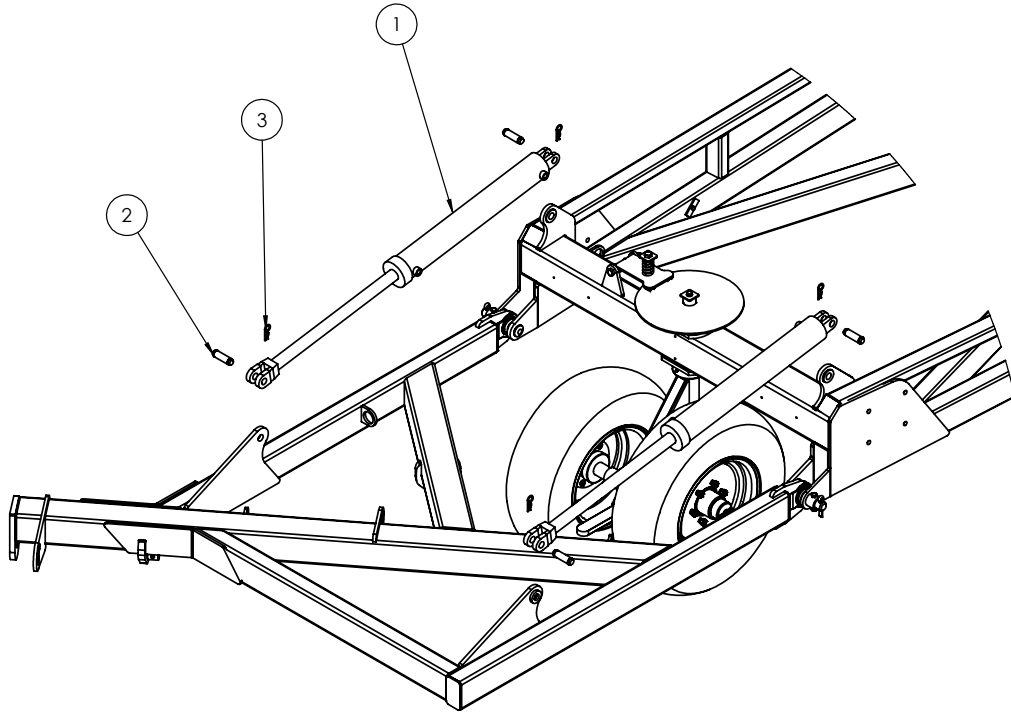

TRAVEL

ITEM NO.	PART NUMBER	DESCRIPTION	Qty
1	0800-235	Rear Tail Guard	2
2	0271-1215577	U-Bolt M12 x 155 Deep x 77 Wide	6
3	0231-F12	M12 zp Flat Washer	12
4	0221-NYL12	M12 Nyloc Nut	12
5	0800-220.1	Tail Chain Stop Guard	1

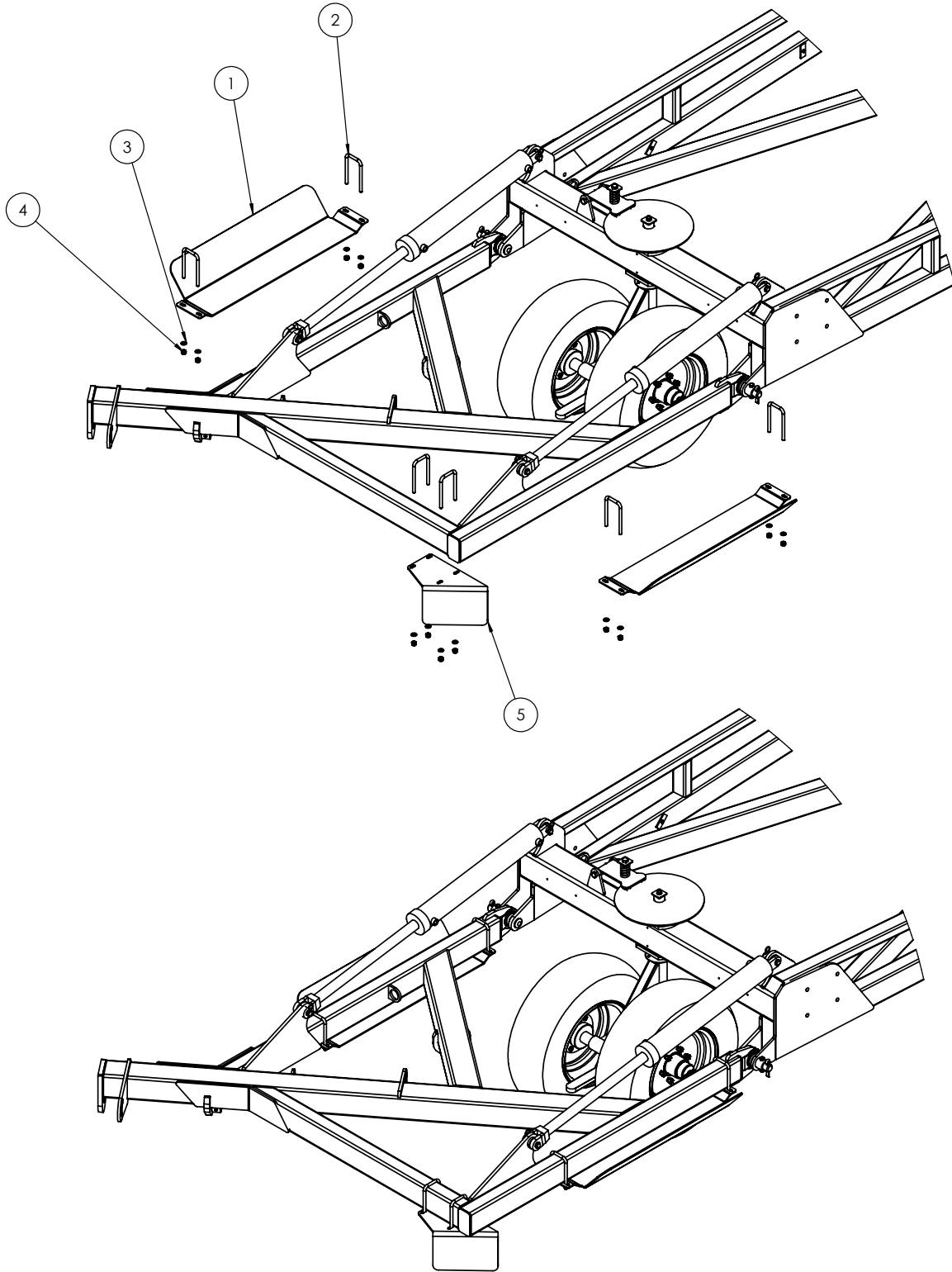

ITEM NO.	PART NUMBER	DESCRIPTION	Qty
1	0800-120.3	Module Lift Plate	1
2	0311-5041	Hyd Cylinder 2.5" x 6" Side Port	1
3	0801-KE0307-1	Clevis Pin 25mm x 75mm	1
4	0801-44082938	Clevis Pin 1" x 75mm	2
5	0511-RCLIP4	R Clip 4mm	2
6	0261-PINC550	Cotter Pin M5 x 50	1
7	0231-F24	M24 zp Flat Washer	1
8	0800-167.3	Module Cylinder Guard	1
9	0211-1250	M12 x 50 8.8 zp Bolt	2
10	0221-NYL12	M12 Nyloc Nut	2

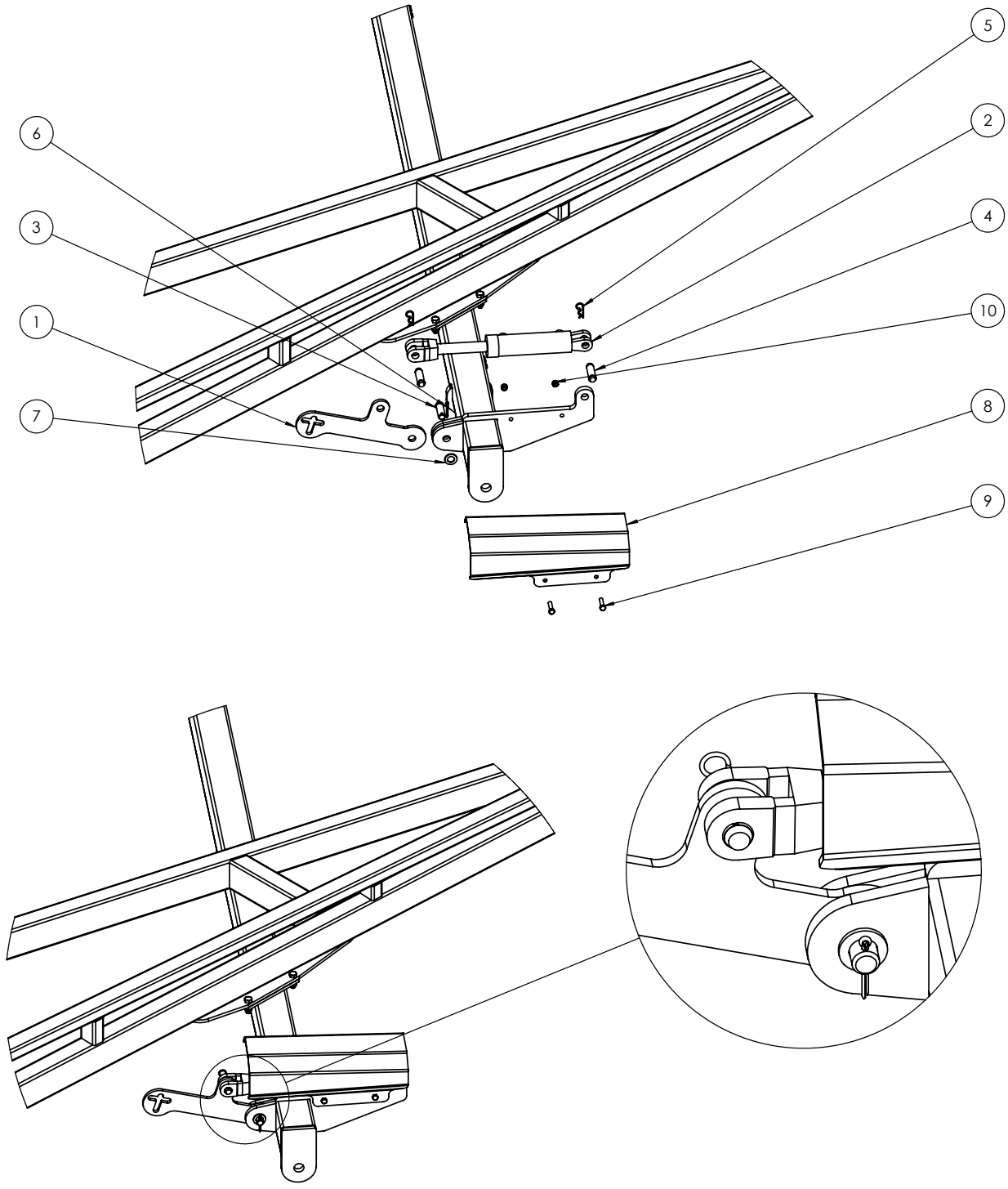

TRAVEL →

ITEM NO.	PART NUMBER	DESCRIPTION	Qty
1	0800-120.3	Module Lift Plate	1
2	0311-5041	Hyd Cylinder 2.5" x 6" Side Port	1
3	0801-KE0307-1	Clevis Pin 25mm x 75mm	1
4	0801-44082938	Clevis Pin 1" x 75mm	2
5	0511-RCLIP4	R Clip 4mm	2
6	0261-PINC550	Cotter Pin M5 x 50	1
7	0231-F24	M24 zp Flat Washer	1

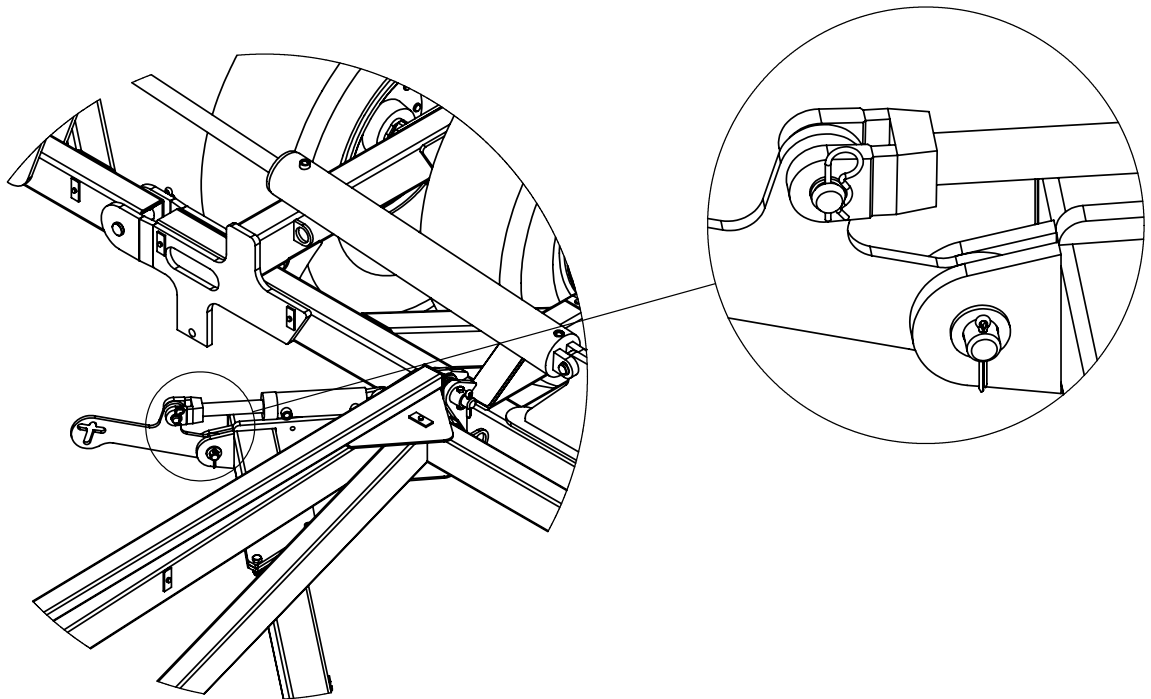
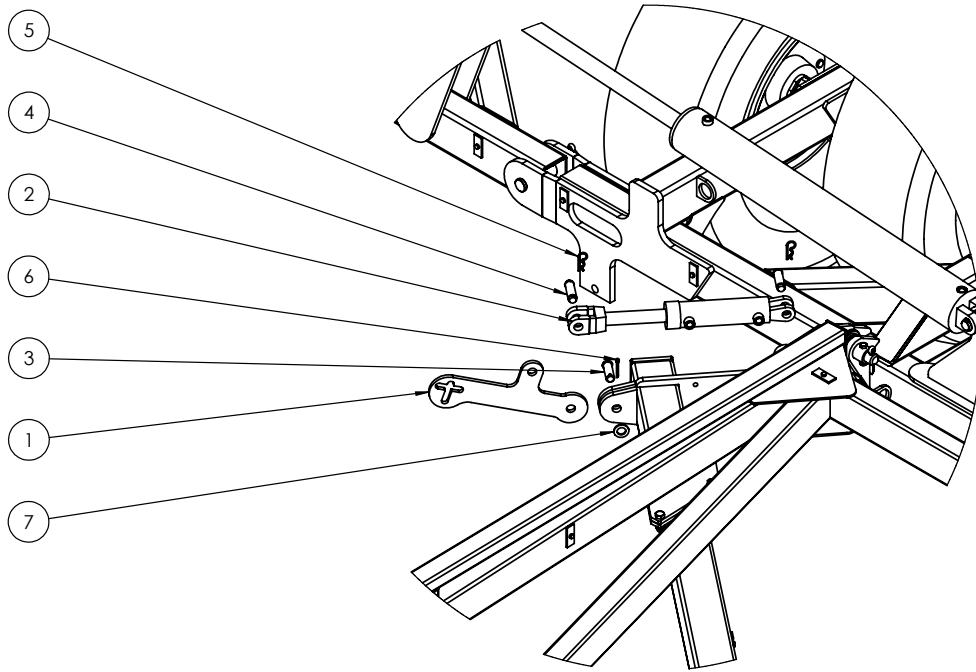

TRAVEL →

ITEM NO.	PART NUMBER	DESCRIPTION	Qty
1	0800-120.3	Module Lift Plate	1
2	0311-5041	Hyd Cylinder 2.5" x 6" Side Port	1
3	0801-44082938	Clevis Pin 1" x 75mm	2
4	0801-KE0307-1	Clevis Pin 25mm x 75mm	1
5	0511-RCLIP4	R Clip 4mm	2
6	0231-F24	M24 zp Flat Washer	1
7	0261-PINC550	Cotter Pin M5 x 50	1

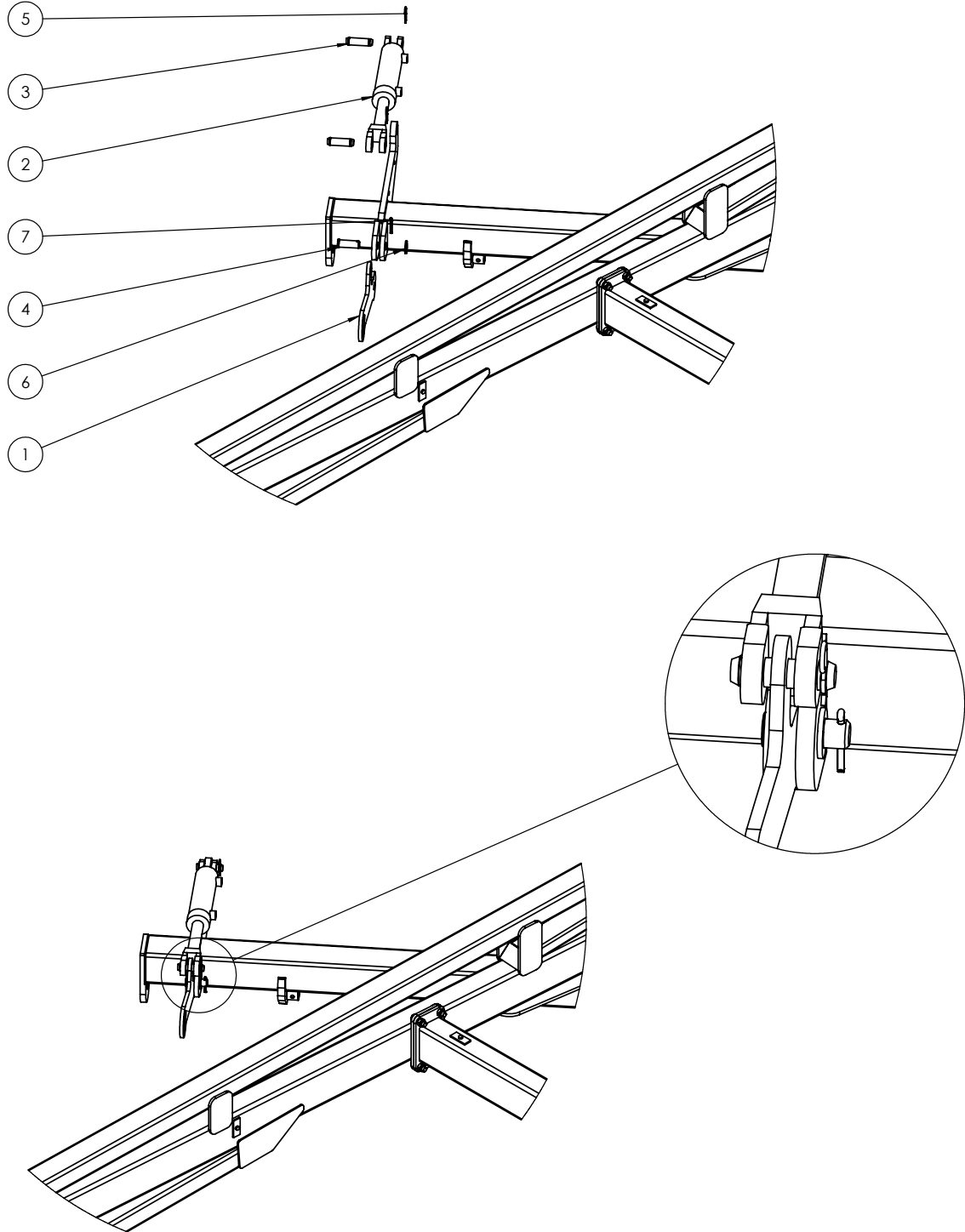

TRAVEL →

ITEM NO.	PART NUMBER	DESCRIPTION	Qty
1	0810-17-60	50/60' Chain Carrier Beam	1
2	0810-17L	Chain Carrier Bolt on End	2
3	0215-CH1240	M12 x 40 Coach Head Bolt	8
4	0231-F12	M12 zp Flat Washer	8
5	0221-NYL12	M12 Nyloc Nut	8

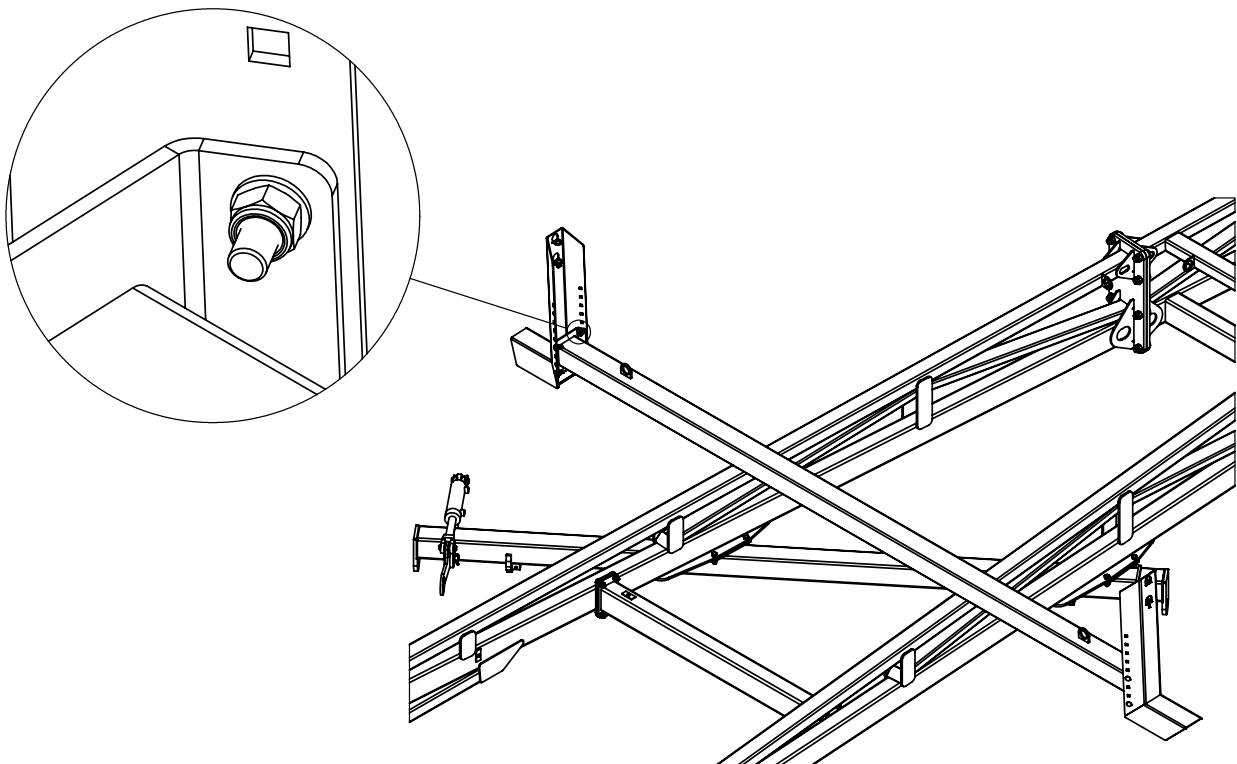
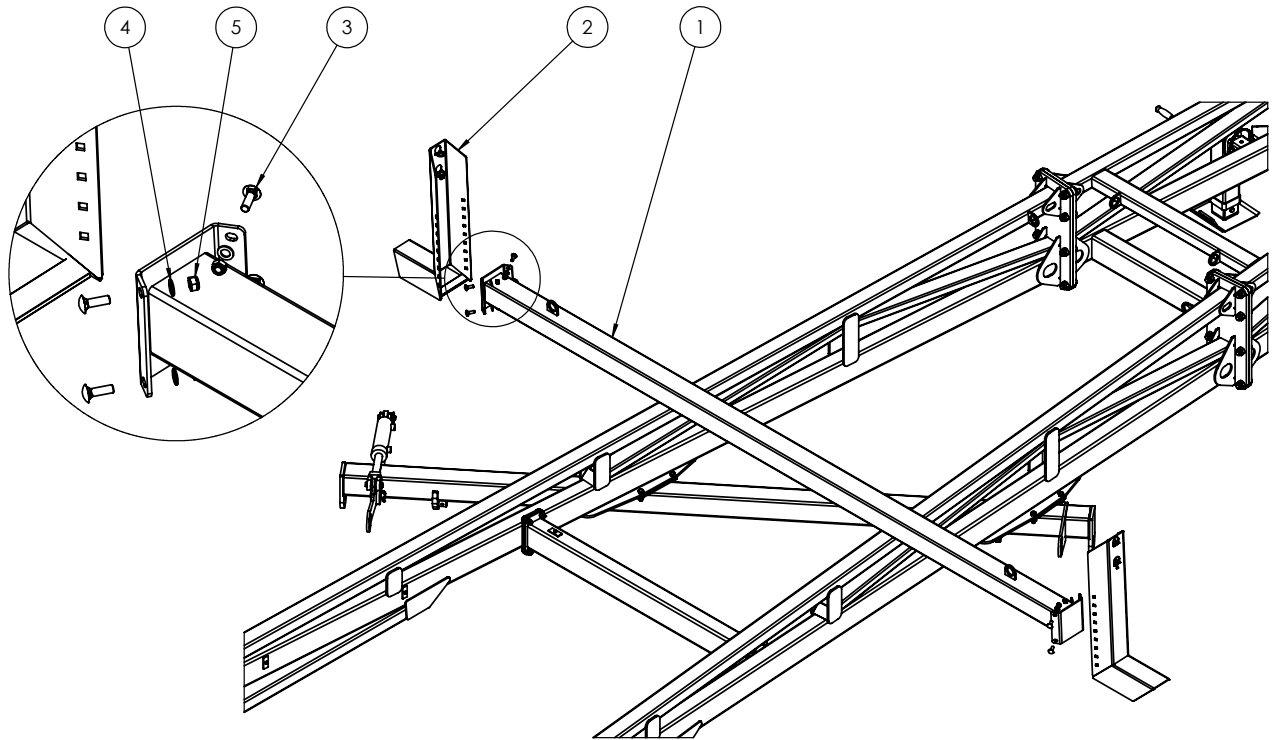

TRAVEL →

ITEM NO.	PART NUMBER	DESCRIPTION	Qty
1	0800-139.1	Chain Carrier Mount Plate	2
2	0271-16112104	U-Bolt M16 x 112 Deep x 104 Wide	4
3	0271-16160127	U-Bolt M16 x 160 Deep x 127 Wide	4
4	0231-F16	M16 zp Flat Washer	16
5	0221-NYL16	M16 Nyloc Nut	16

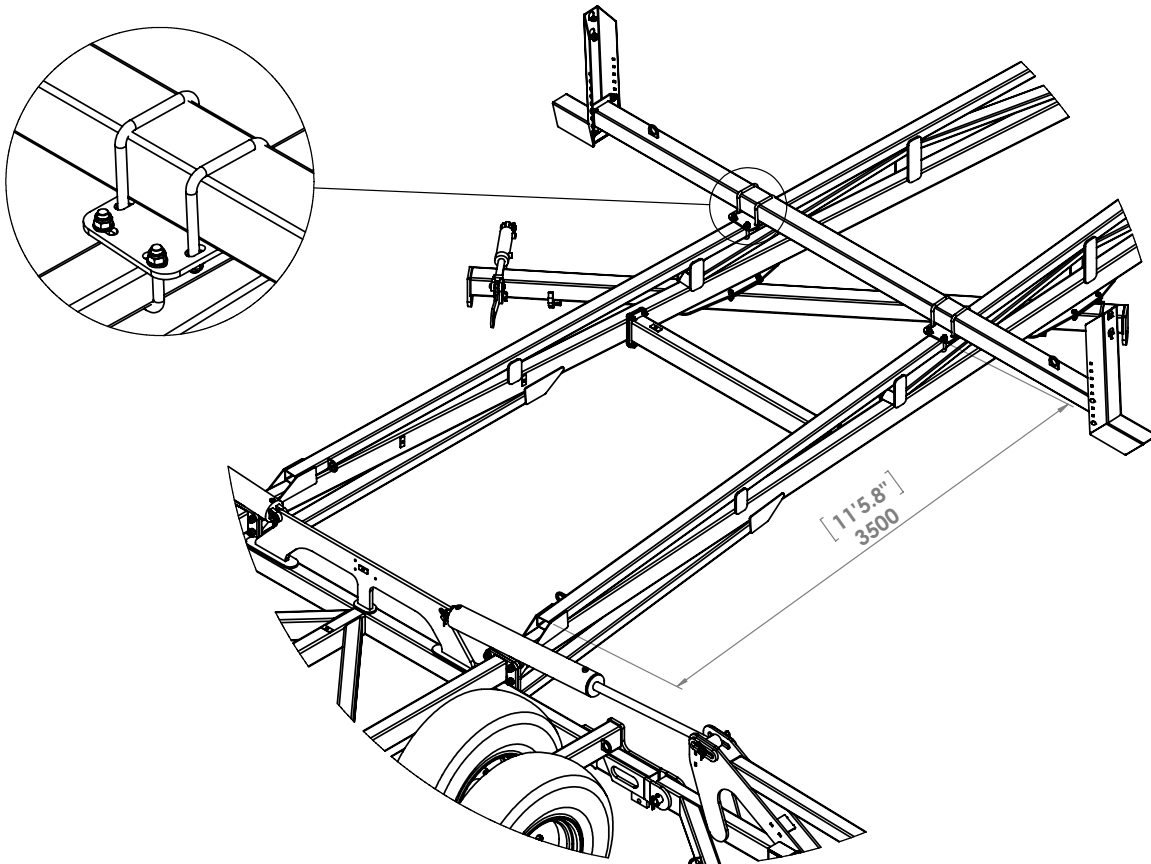
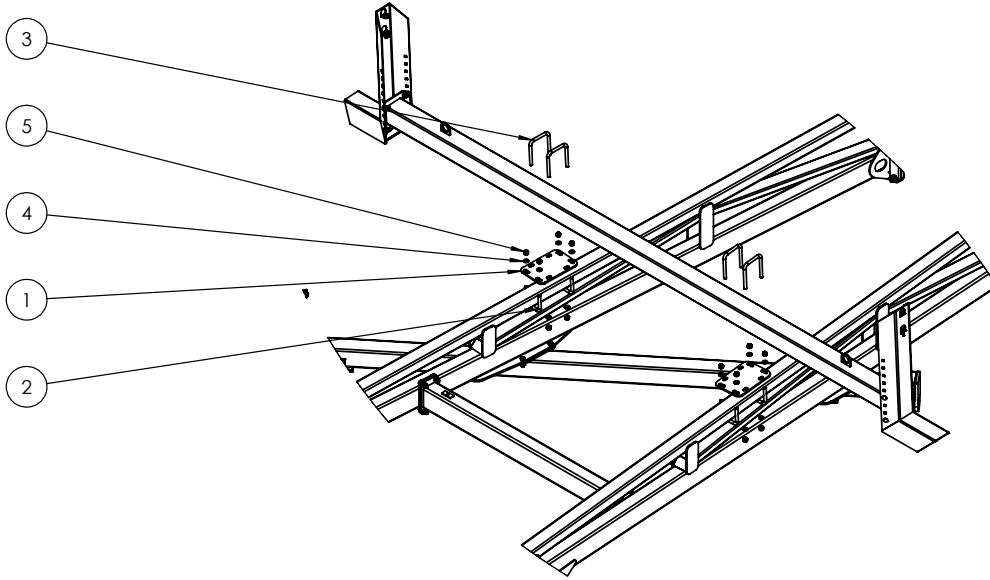

ITEM NO.	PART NUMBER	DESCRIPTION	Qty
1	0810-18R	Right Hand Off Set M	1
2	0810-19L	Left Hand Off Set M	1
3	0271-12105104	U-Bolt M12 x 105 Deep x 104 Wide	4
4	0231-F12	M12 zp Flat Washer	8
5	0221-NYL12	M12 Nyloc Nut	8
6	0264-RTRI-5584	Round Tube Insert 60.3 x 3.2-5mm	4

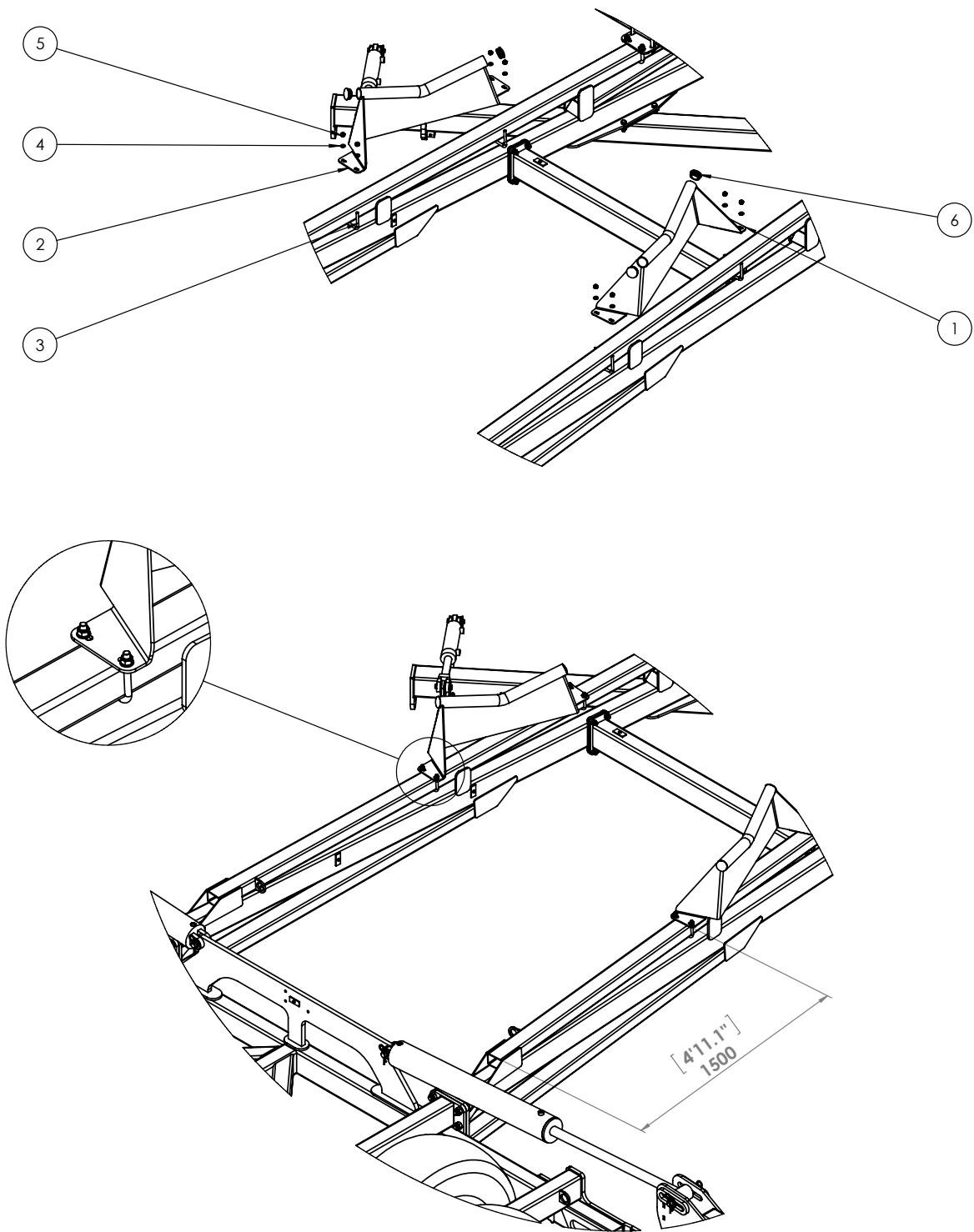

ITEM NO.	PART NUMBER	DESCRIPTION	Qty
1	0800-228.1	60" Rear A-Frame Guard	1
2	0271-12105104	U-Bolt M12 x 105 Deep x 104 Wide	2
3	0231-F12	M12 zp Flat Washer	4
4	0221-NYL12	M12 Nyloc Nut	4

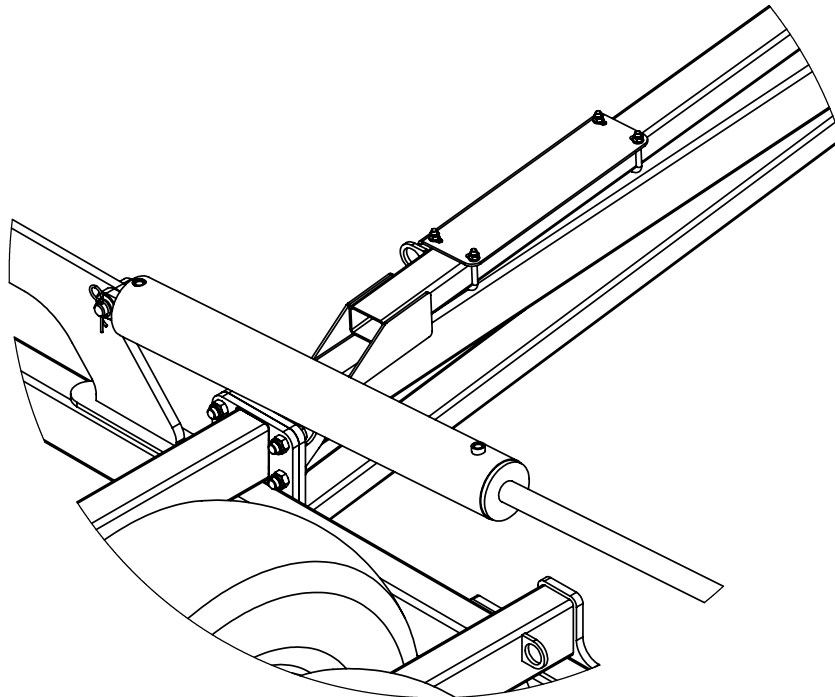
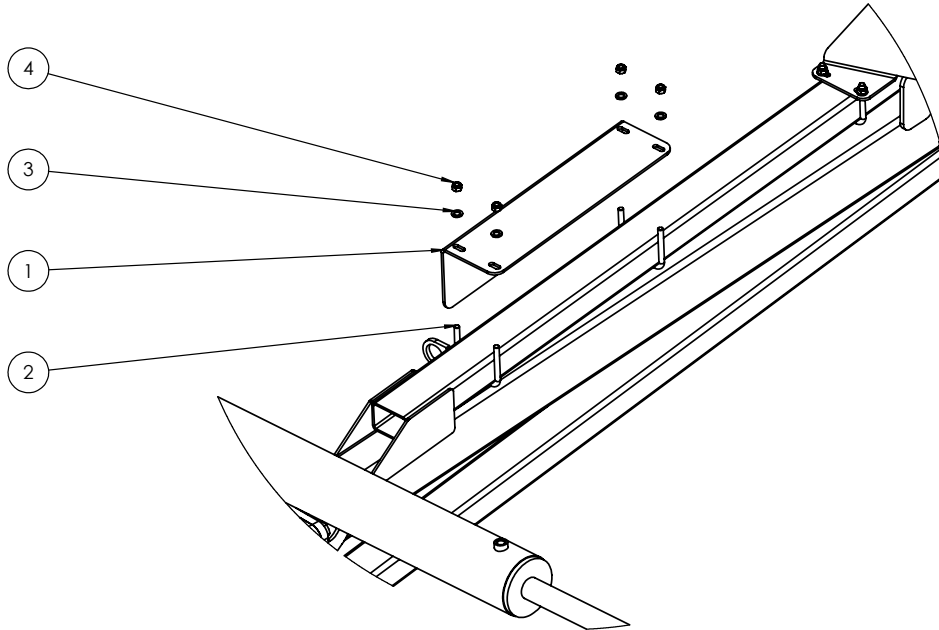

TRAVEL →

ITEM NO.	PART NUMBER	DESCRIPTION	Qty
1	0810-17-60	50/60' Chain Carrier Beam	1
2	0810-17L	Chain Carrier Bolt on End	2
3	0231-F12	M12 zp Flat Washer	8
4	0221-NYL12	M12 Nyloc Nut	8
5	0215-CH1240	M12 x 40 Coach Head Bolt	8

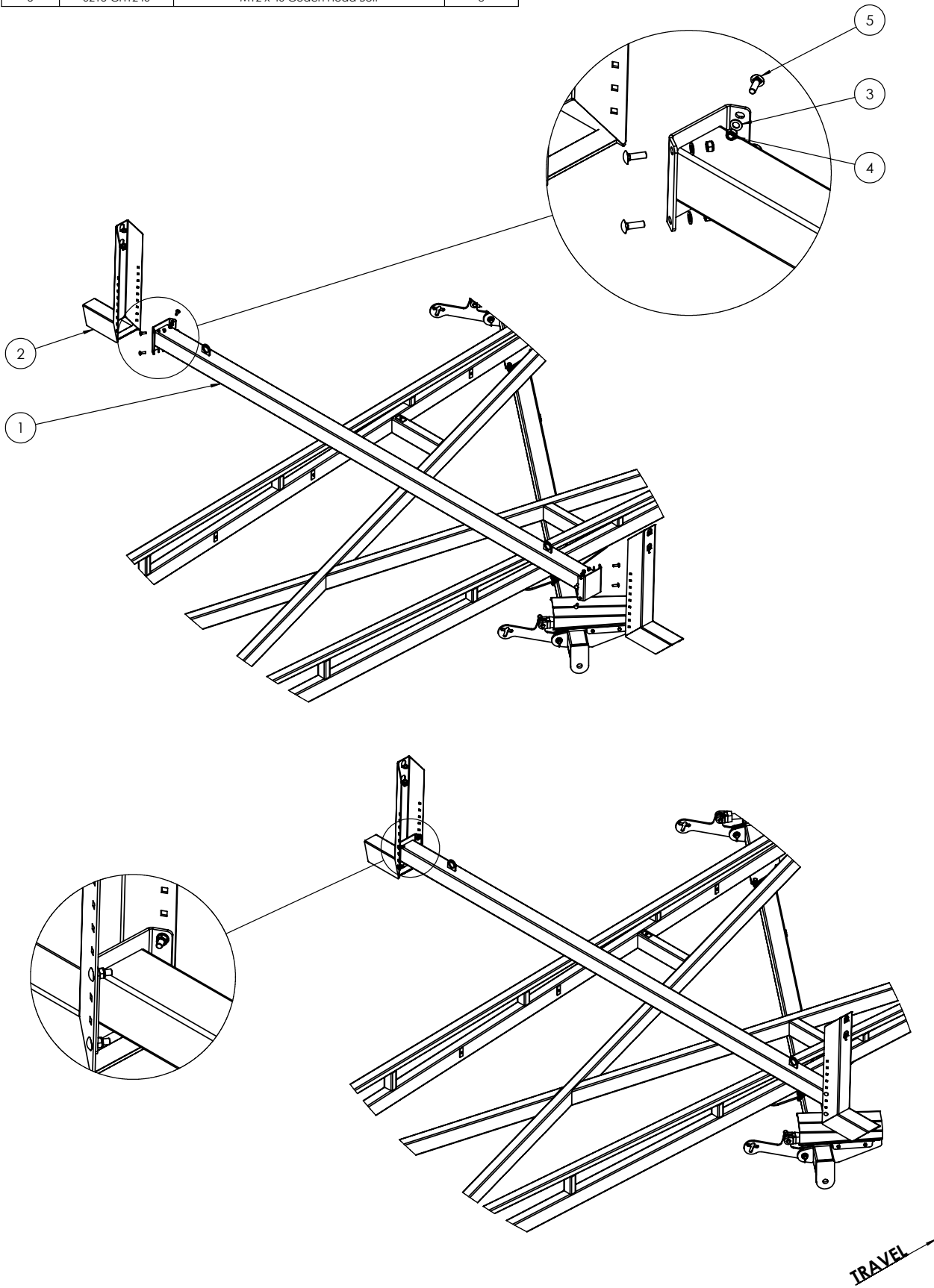

ITEM NO.	PART NUMBER	DESCRIPTION	Qty
1	0810-23-60	60CT Chain Carrier Pedestal	2
2	0271-168577	U-Bolt M16 x 85 Deep X 77 Wide	4
3	0271-16160127	U-Bolt M16 x 160 Deep x 127 Wide	4
4	0231-F16	M16 zp Flat Washer	16
5	0221-NYL16	M16 Nyloc Nut	16

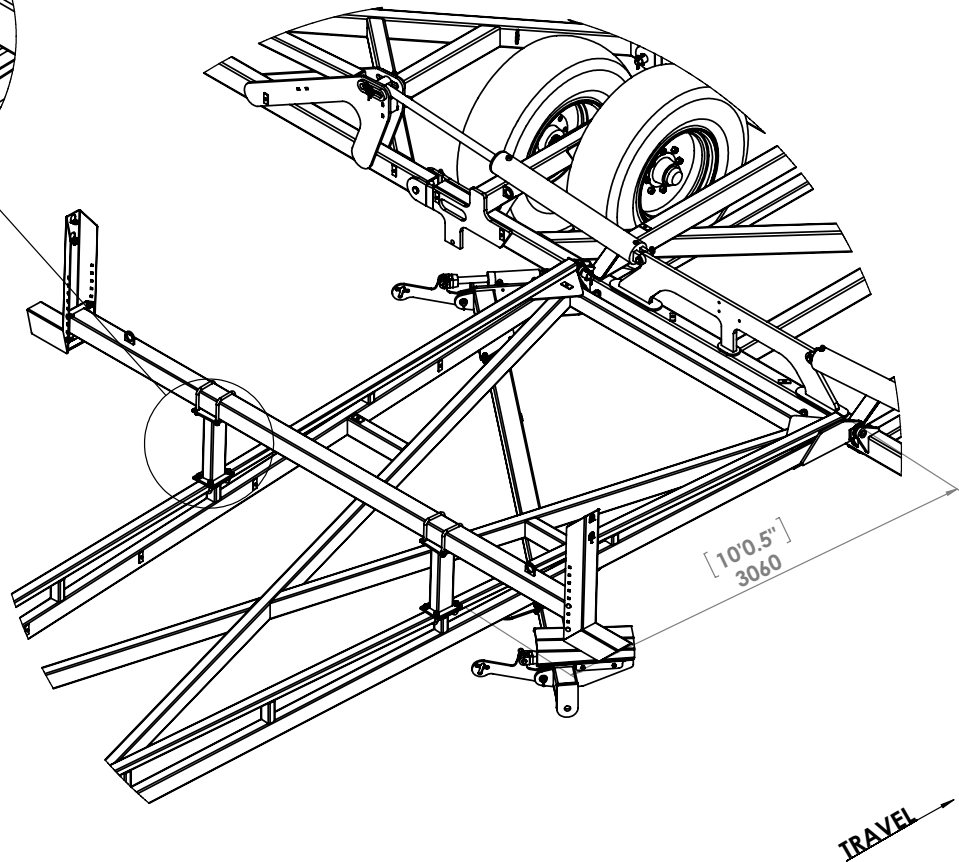
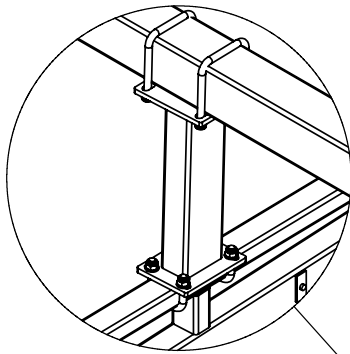
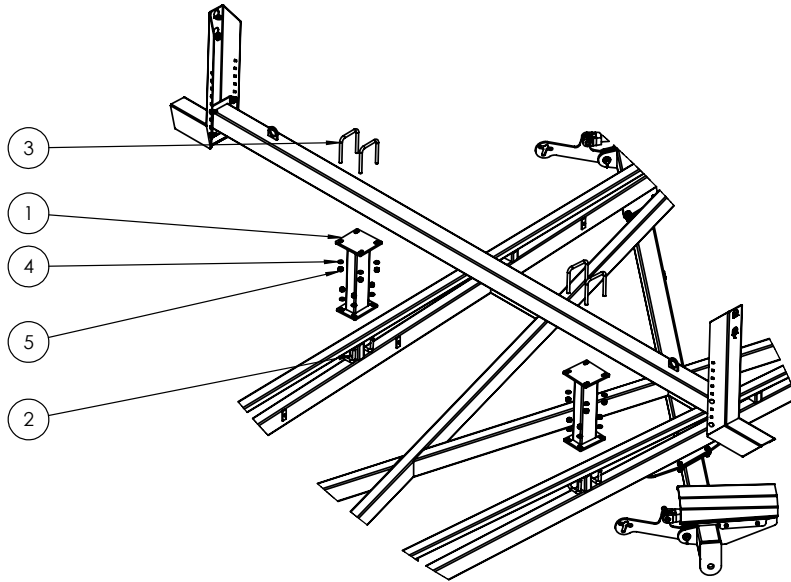

ITEM NO.	PART NUMBER	DESCRIPTION	Qty
1	0800-229.1	Rear Module Guard 60'/65'	1
2	0271-12155127	U-Bolt M12 x 155 Deep x 127 Wide	2
3	0231-F12	M12 zp Flat Washer	4
4	0221-NYL12	M12 Nyloc Nut	4

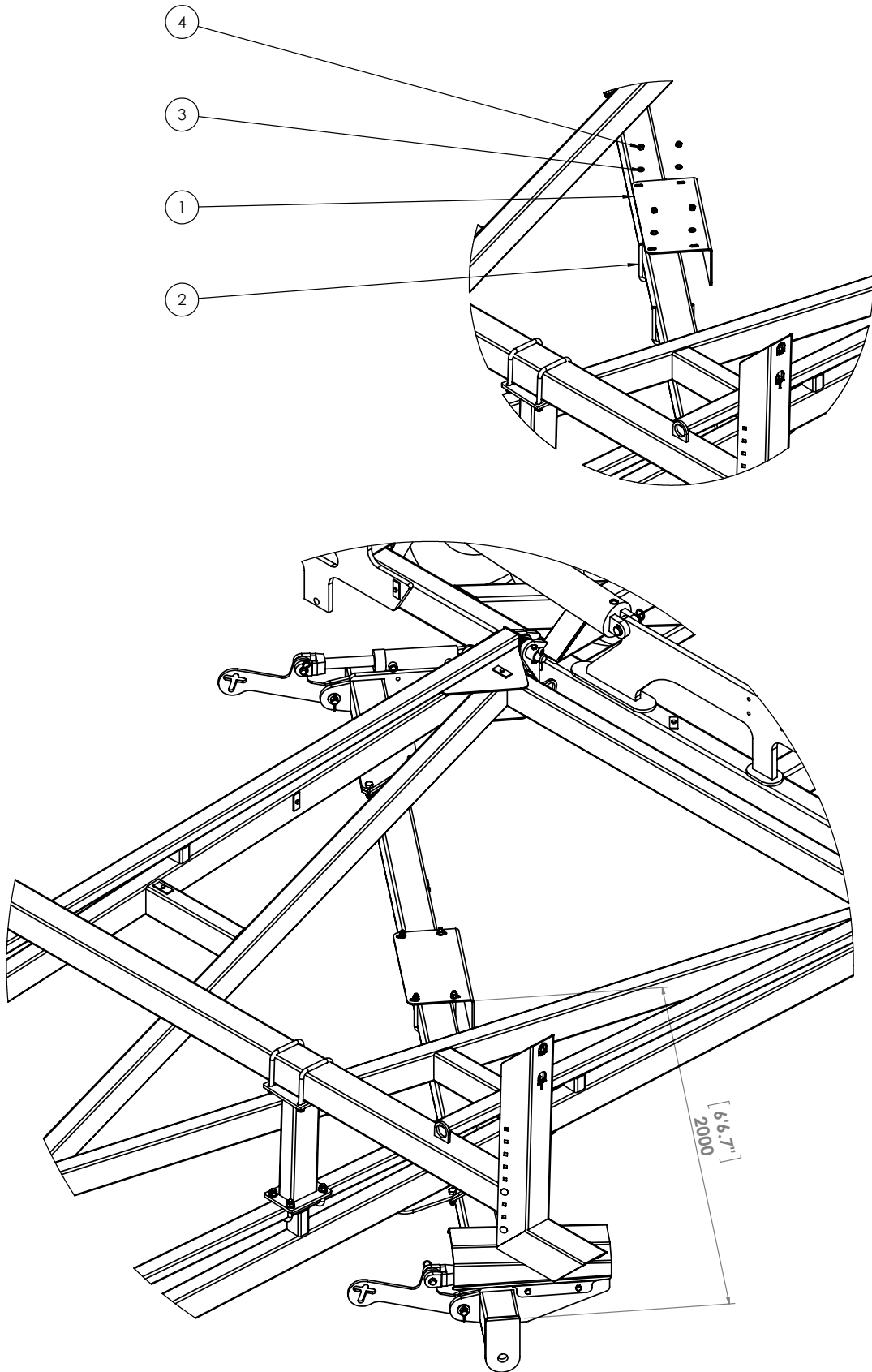

ITEM NO.	PART NUMBER	DESCRIPTION	Qty
1	0264-RTRI-5584	Round Tube Insert 60.3 x 3.2-5mm	8
2	0810-18R	Right Hand Off Set M	1
3	0810-19L	Left Hand Off Set M	1
4	0810-19	Straight Chain Carrier M	2
5	0271-128077	U-Bolt M12 x 80 Deep x 77 Wide	4
6	0271-1215577	U-Bolt M12 x 155 Deep x 77 Wide	4
7	0231-F12	M12 zp Flat Washer	16
8	0221-NYL12	M12 Nyloc Nut	16

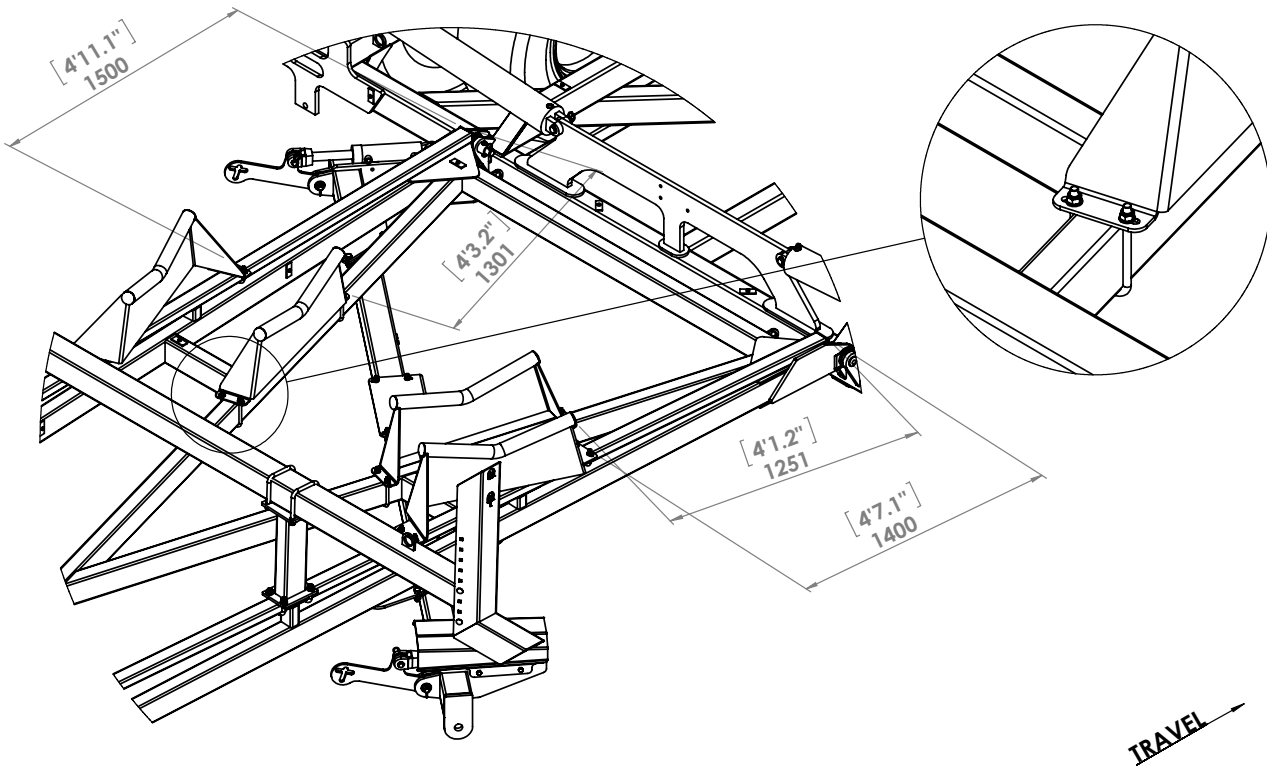
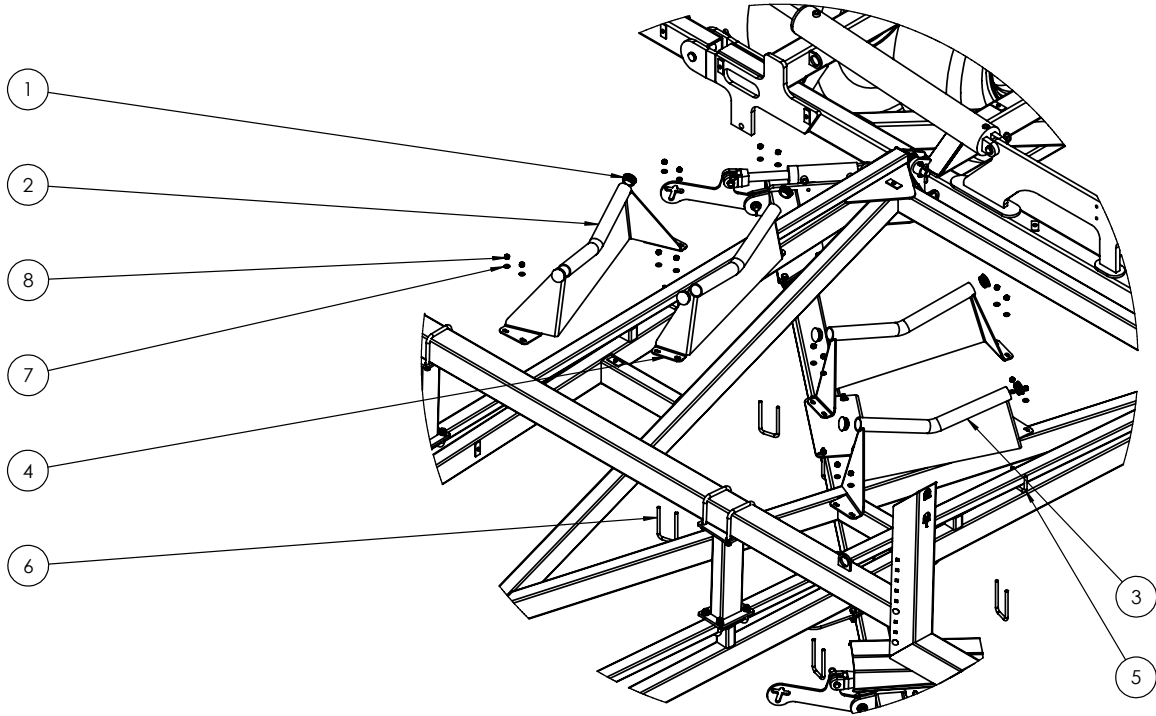

ITEM NO.	PART NUMBER	DESCRIPTION	Qty
1	0800-228.1	60' Rear A-Frame Guard	1
2	0271-1215577	U-Bolt M12 x 155 Deep x 77 Wide	2
3	0231-F12	M12 zp Flat Washer	4
4	0221-NYL12	M12 Nyloc Nut	4

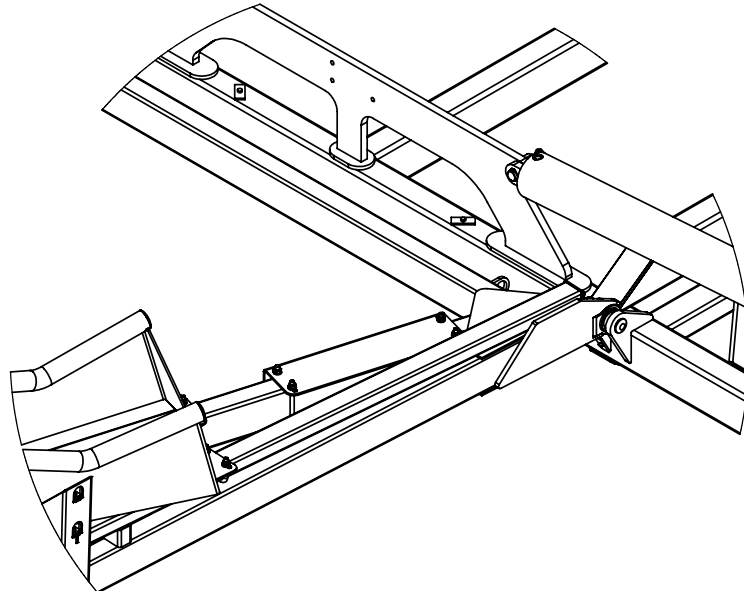
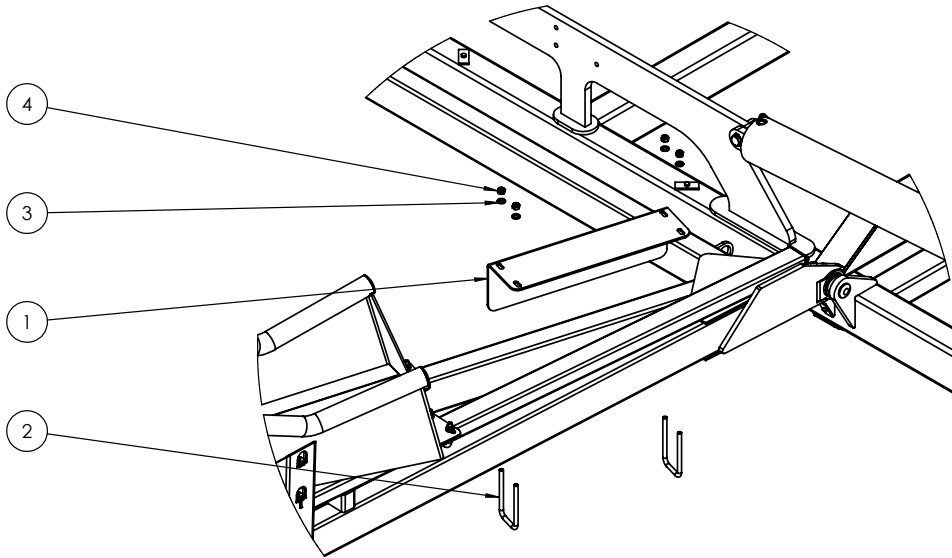

TRAVEL

ITEM NO.	PART NUMBER	DESCRIPTION	Qty
1	0810-17L	Chain Carrier Bolt on End	1
2	0810-109	Outrigger	1
3	0810-110	LH Oversize Sign Frame	1
4	0801-SIGNOSL	Oversize Sign Left Hand	1
5	0271-12155127	U-Bolt M12 x 155 Deep x 127 Wide	2
6	0231-F12	M12 zp Flat Washer	8
7	0221-NYL12	M12 Nyloc Nut	8
8	0241-TEK10-1616	TEK Screw 10g 16 x 16	10
9	0211-1655	M16 x 55 8.8 zp Bolt	4
10	0221-NYL16	M16 Nyloc Nut	4
11	0215-CH1240	M12 x 40 Coach Head Bolt	4

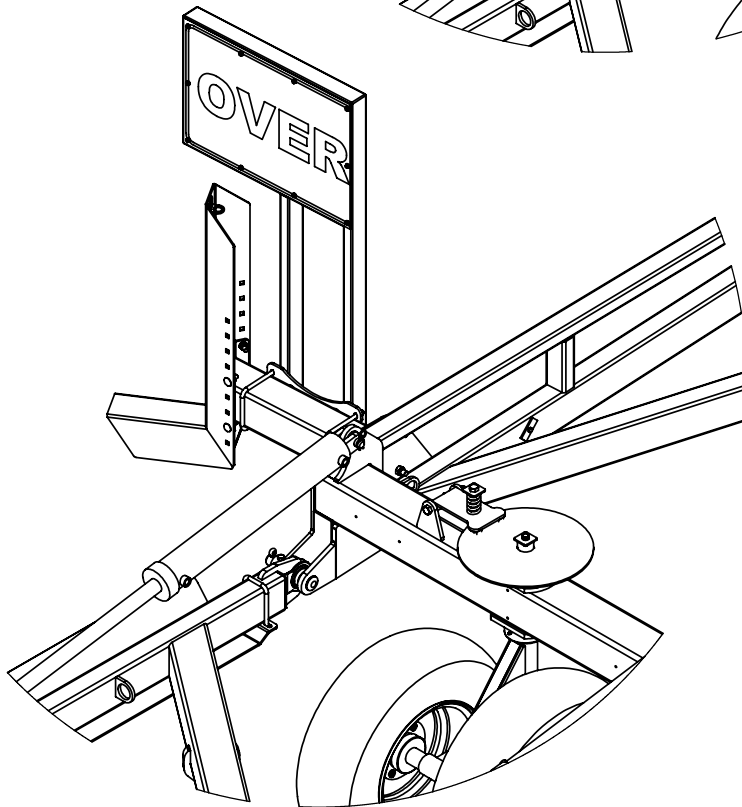
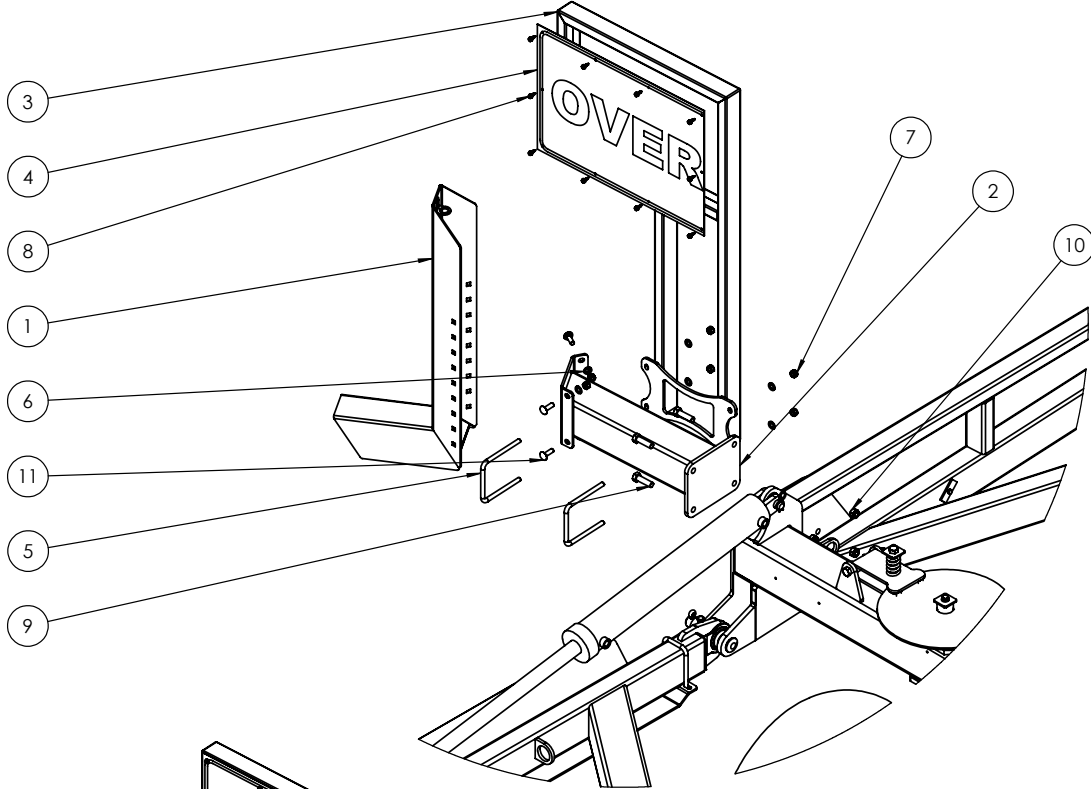

TRAVEL

ITEM NO.	PART NUMBER	DESCRIPTION	Qty
1	0810-17L	Chain Carrier Bolt on End	1
2	0810-109	Outrigger	1
3	0271-12155127	U-Bolt M12 x 155 Deep x 127 Wide	2
4	0231-F12	M12 zp Flat Washer	8
5	0221-NYL12	M12 Nyloc Nut	8
6	0241-TEK10-1616	TEK Screw 10g 16 x 16	8
7	0211-1655	M16 x 55 8.8 zp Bolt	4
8	0221-NYL16	M16 Nyloc Nut	4
9	0801-SIGNOSR	Oversize Sign Right Hand	1
10	0810-111	RH Oversize Sign Frame	1
11	0215-CH1240	M12 x 40 Coach Head Bolt	4

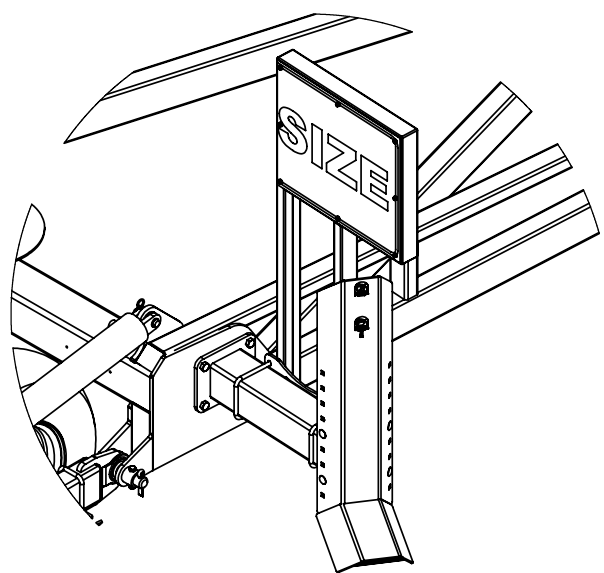
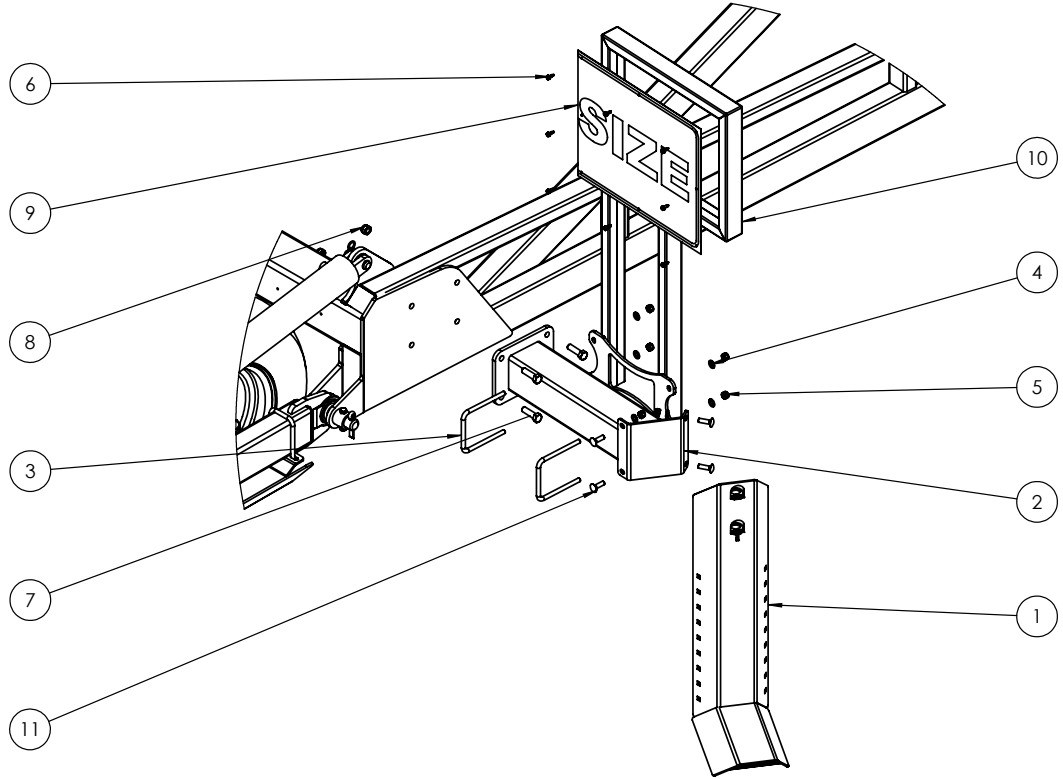

TRAVEL

ITEM NO.	PART NUMBER	DESCRIPTION	Qty
1	0801-PS50	50mm Drop Leg Spacer	2
2	0801-PS25	25mm Drop leg Spacer	4
3	0801-PCDCS55	Tie Plate Bush	2
4	0802-PCHB553	24mm Bolt Swivel Unit	2
5	0802-DCTP-24	Disc Chain Tie Plate Link 24mm	2
6	0810-26	LH Chain Adjusting Lug	1
7	0810-27	RH Chain Adjusting Lug	1
8	0810-24-60	LH Drop Leg 24mm Clevis	1
9	0810-25-60	RH Drop Leg 24mm Clevis	1
10	0243-STSG1.25ZP	Poly Spacer Clamp Screw	6
11	0211-24140	M24 x 140 8.8 zp Bolt	2
12	0221-NYL24	M24 Nyloc Nut	8
13	0211-24120ST	M24 x 120 Short Thread 8.8 zp Bolt	6

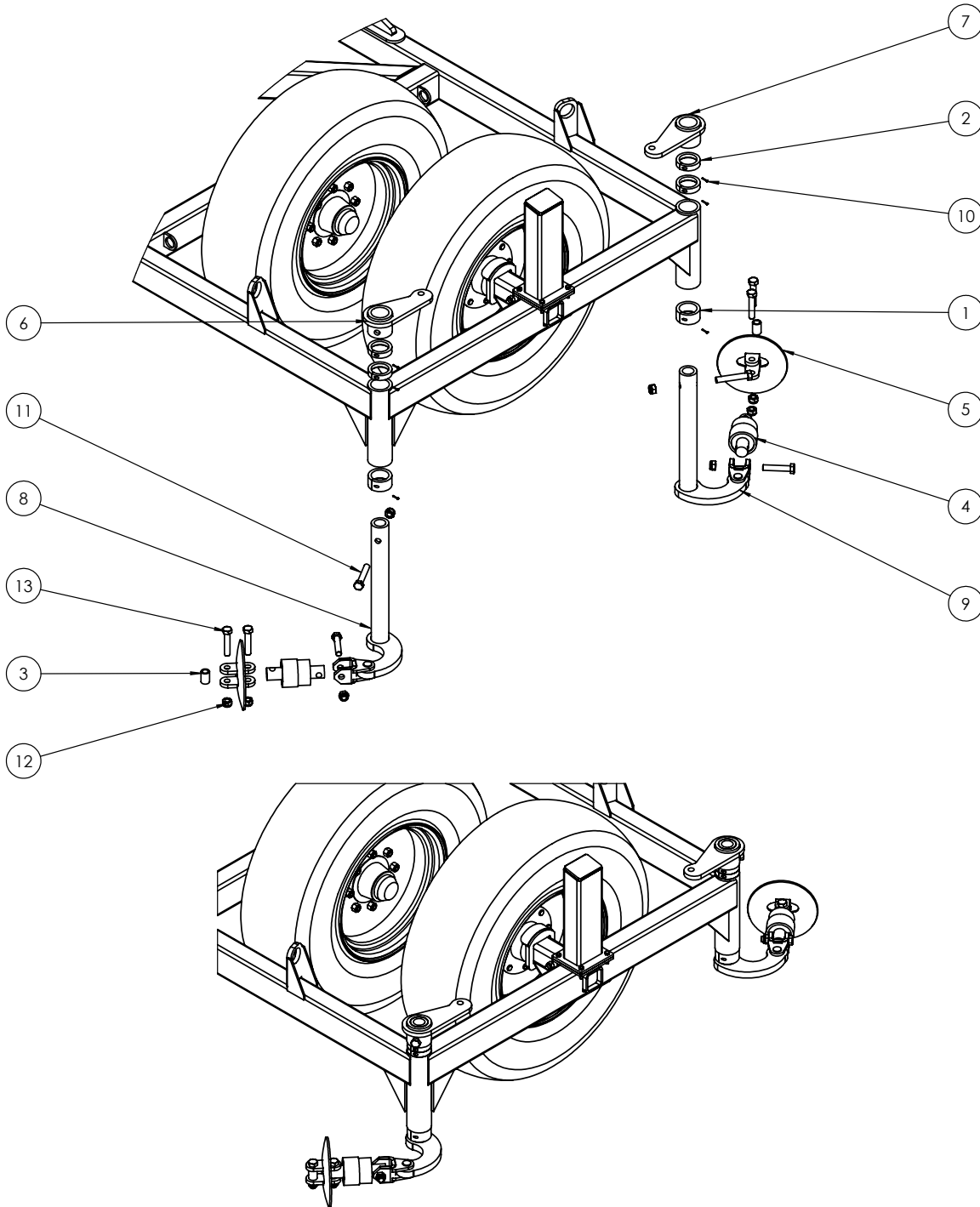

TRAVEL →

ITEM NO.	PART NUMBER	DESCRIPTION	Qty
1	0801-KE0805-4	Female Spring Locator	2
2	0801-KE0805-3	Tensioner Cup - Male	2
3	0801-PCHTABC	Tension Assembly Body with Clevis	2
4	0801-PCHTA-B6	6tpi 1.25" Tension Bolt	2
5	0801-PCHTA-SB	Steel Spring Retaining Bush	2
6	0801-PCHTA-N6	1 1/4" 6 tpi ACME Lock Nut	6
7	0801-XK9261S	20mm Compression Spring	1
8	0801-K2455350	Heavy Duty Coil Spring 24mm	1
9	0801-KE0307-1	Clevis Pin 25mm x 75mm	2
10	0261-PINC550	Cotter Pin M5 x 50	2
11	0232-HT11-4	Washer High Tensile 1 1/4"	2
12	0181-GN1-4	Grease Nipple 1/4" UNF	2

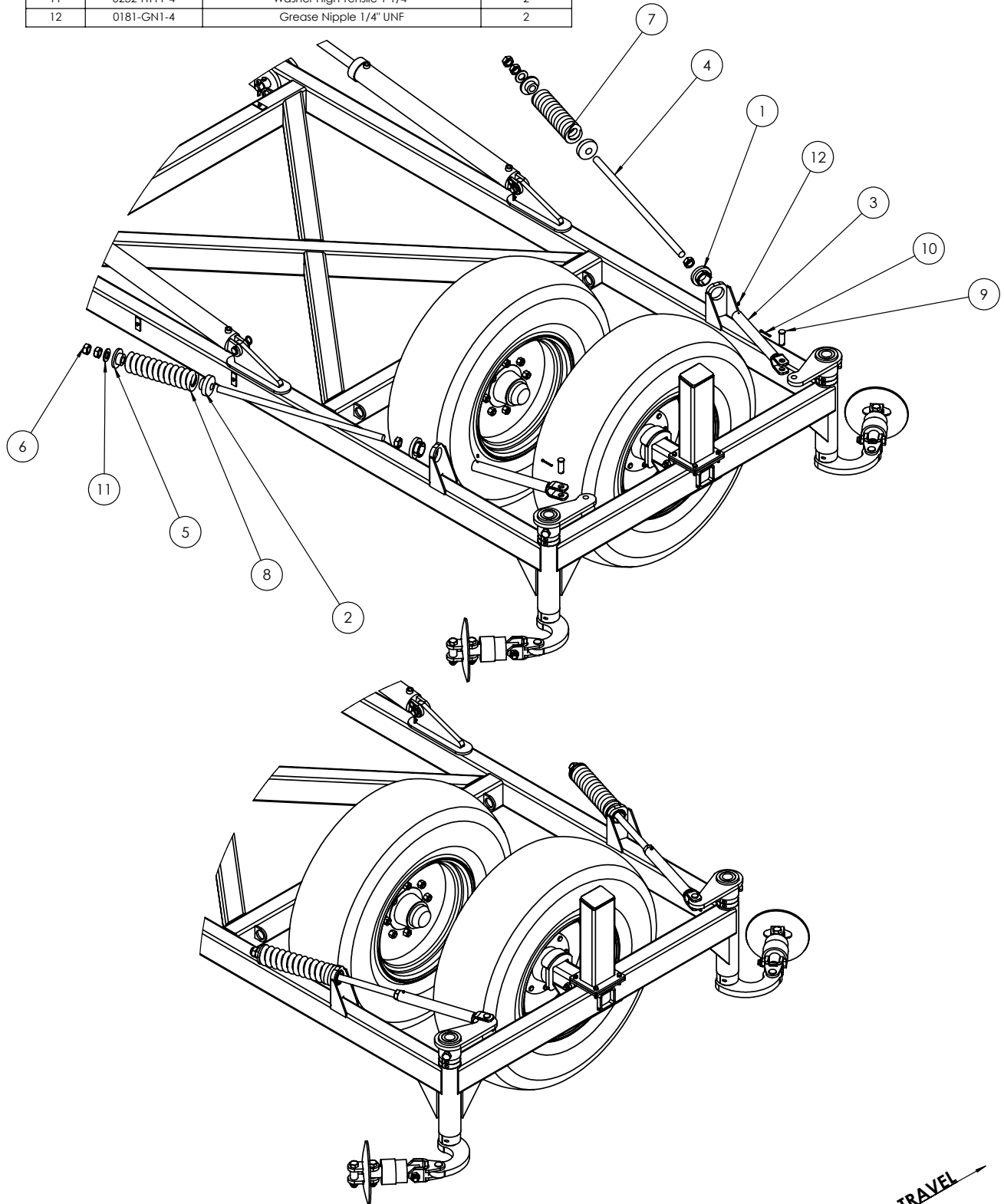

ITEM NO.	PART NUMBER	DESCRIPTION	Qty
1	0810-25-60	RH Drop Leg 24mm Clevis	1
2	0810-24-60	LH Drop Leg 24mm Clevis	1
3	0810-26	LH Chain Adjusting Lug	1
4	0810-27	RH Chain Adjusting Lug	1
5	0801-PS25	25mm Drop leg Spacer	4
6	0801-PS50	50mm Drop Leg Spacer	2
7	0801-PCDCS55	Tie Plate Bush	2
8	0802-DCTP-24	Disc Chain Tie Plate Link 24mm	2
9	0802-PCHB553	24mm Bolt Swivel Unit	2
10	0211-24140	M24 x 140 8.8 zp Bolt	2
11	0221-NYL24	M24 Nyloc Nut	8
12	0243-ST58G1.25ZP	Poly Spacer Clamp Screw	6
13	0211-24120ST	M24 x 120 Short Thread 8.8 zp Bolt	6

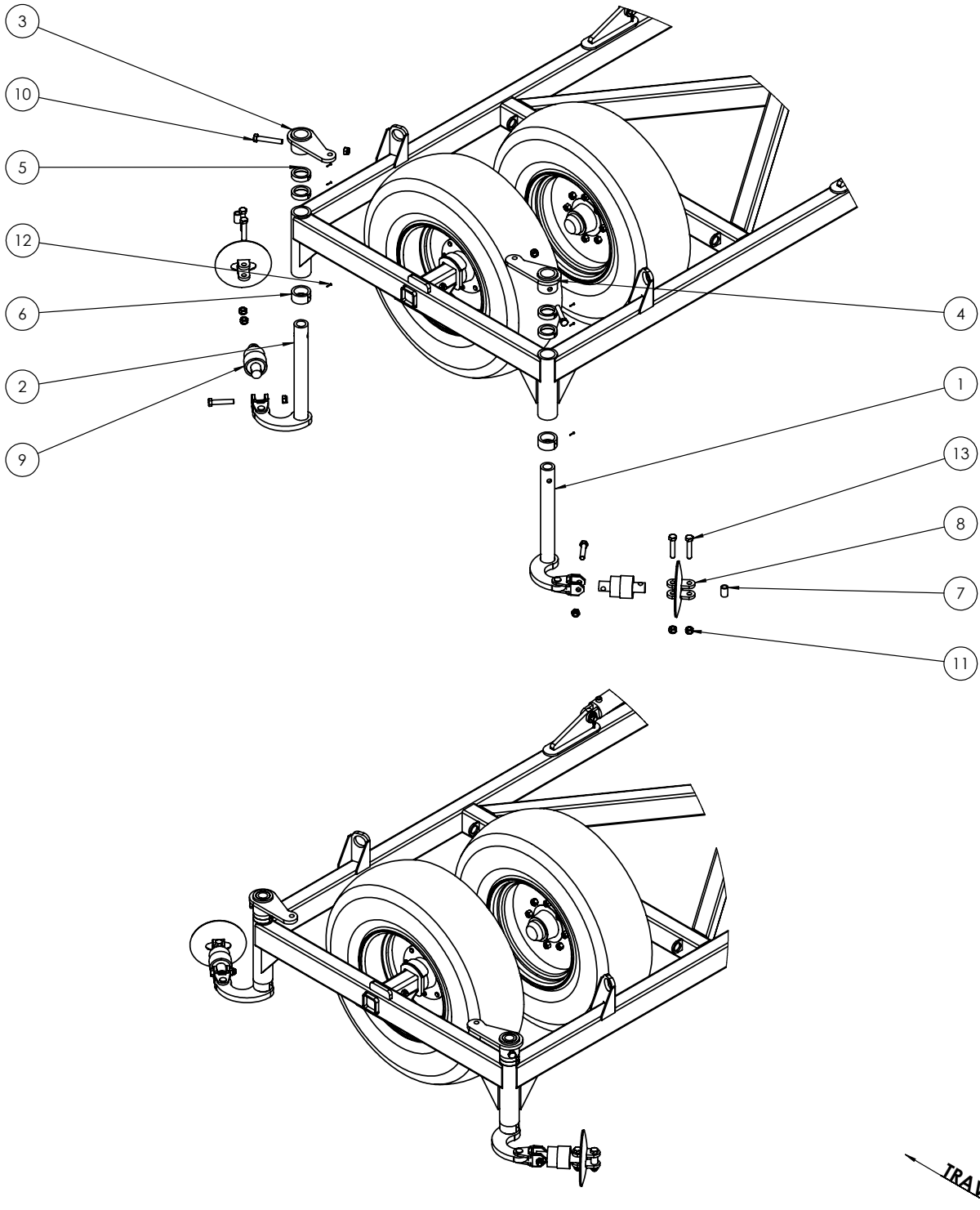

ITEM NO.	PART NUMBER	DESCRIPTION	Qty
1	0801-KE0307-1	Clevis Pin 25mm x 75mm	2
2	0801-KE0805-3	Tensioner Cup - Male	2
3	0801-KE0805-4	Female Spring Locator	2
4	0801-PCHTABC	Tension Assembly Body with Clevis	2
5	0801-PCHTA-SB	Steel Spring Retaining Bush	2
6	0801-PCHTA-B6	6tpi 1.25" Tension Bolt	2
7	0801-XK9261S	20mm Compression Spring	1
8	0801-K2455350	Heavy Duty Coil Spring 24mm	1
9	0232-HT11-4	Washer High Tensile 1 1/4"	2
10	0261-PINC550	Cotter Pin M5 x 50	2
11	0181-GN1-4	Grease Nipple 1/4" UNF	2
12	0801-PCHTA-N6	1 1/4" 6 tpi ACME Lock Nut	6

**PLEASE REFER TO
ASSEMBLY UPDATE 043
IN THE BACK OF THE
MANUAL**

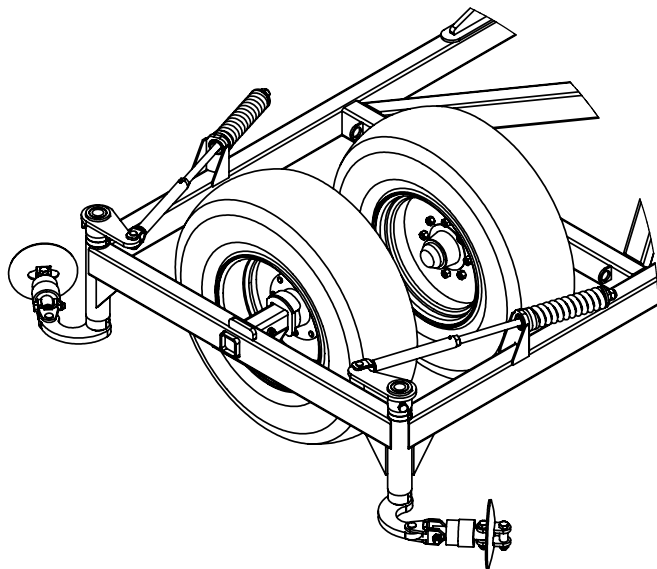
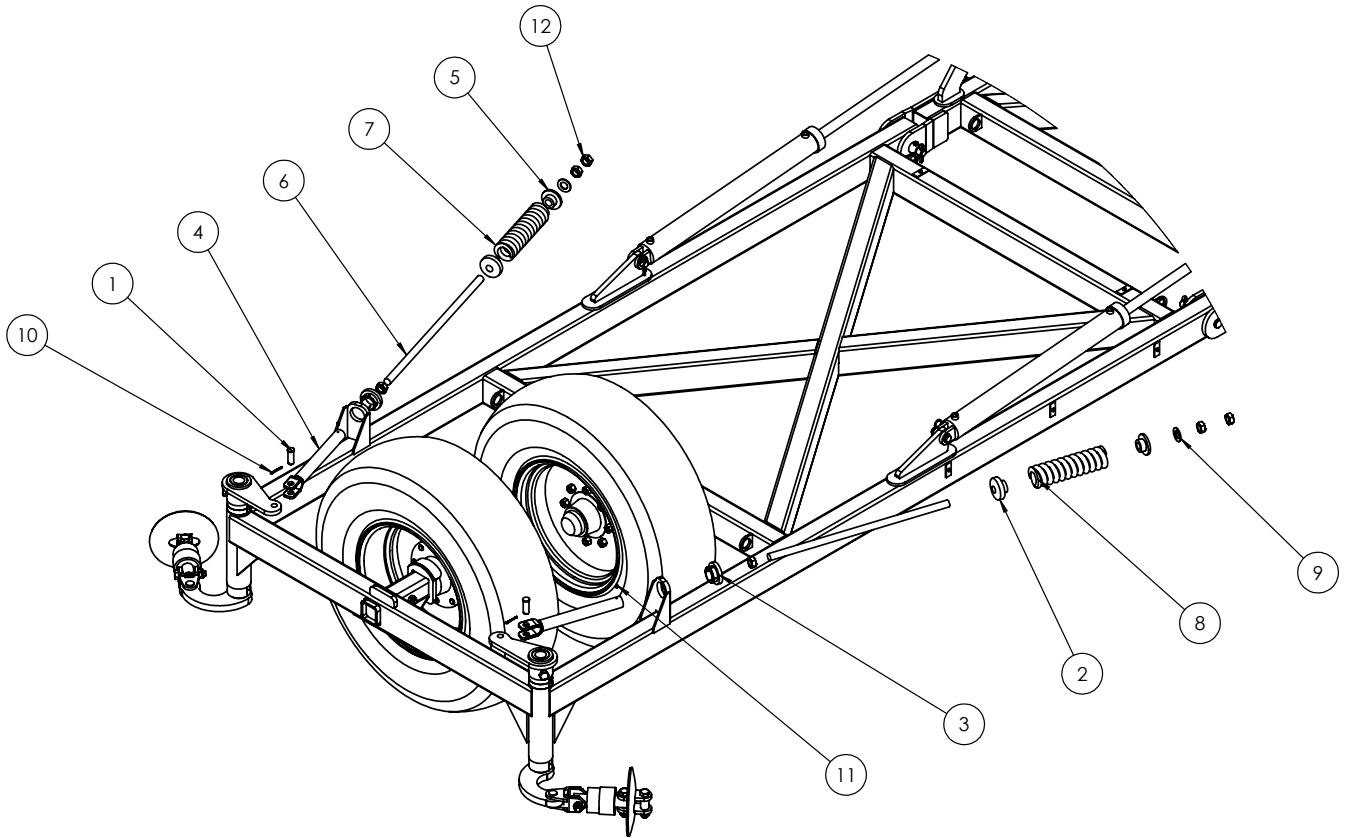

TRAVEL

ITEM NO.	PART NUMBER	DESCRIPTION	Qty
1	0801-10-51	Chain Mount Pivot Pin	1
2	0810-20-60	Chain Mt Arm 24mm Clevis	1
3	0802-PCHB553	24mm Bolt Swivel Unit	1
4	0802-DCTP-24	Disc Chain Tie Plate Link 24mm	1
5	0801-PCH24MCA	Height Adjusting Chain Assembly	1
6	0801-PCDCS55	Tie Plate Bush	1
7	0801-KE014	Height Adjustor Retaining Clip	1
8	0232-HT13-8	Washer High Tensile 1 3/8"	1
9	0211-1265	M12 x 65 8.8 zp Bolt	1
10	0221-NYL12	M12 Nyloc Nut	1
11	0211-24120ST	M24 x 120 Short Thread 8.8 zp Bolt	3
12	0221-NYL24	M24 Nyloc Nut	3

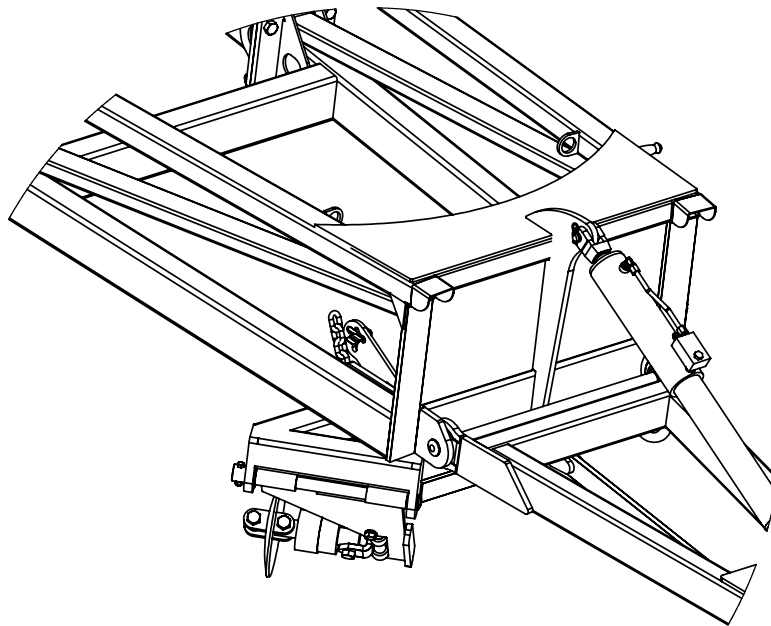
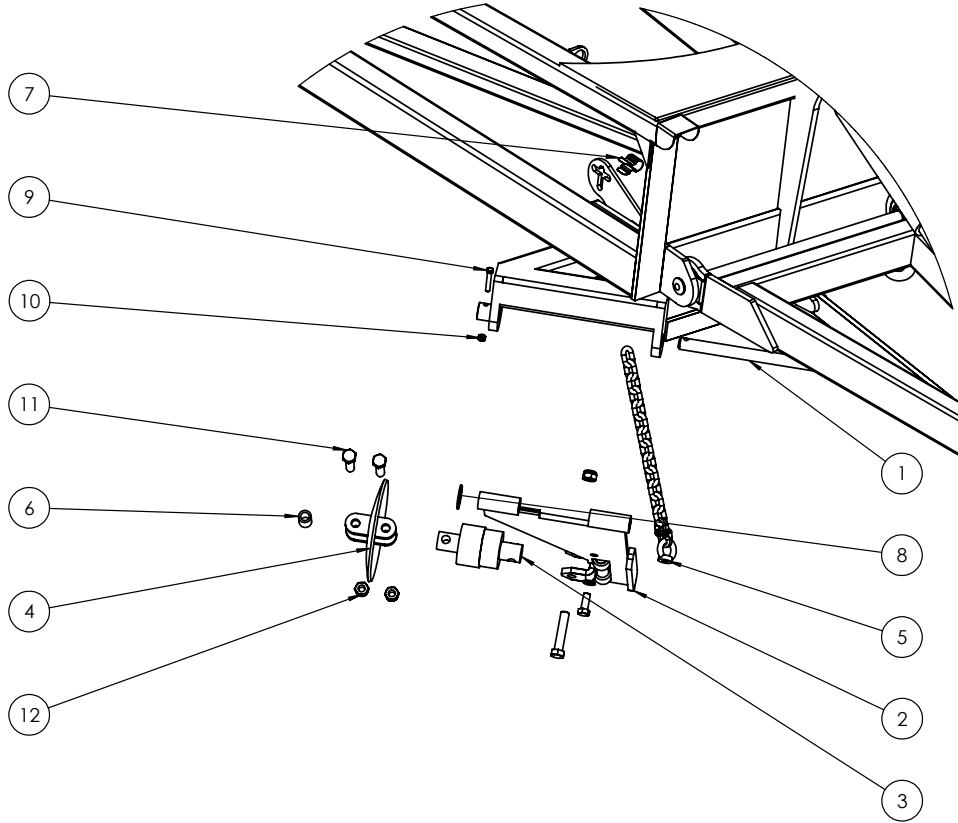

TRAVEL →

ITEM NO.	PART NUMBER	DESCRIPTION	Qty
1	0801-10-51	Chian Mount Pivot Pin	1
2	0801-KE014	Height Adjustor Retaining Clip	1
3	0801-PCDCS55	Tie Plate Bush	1
4	0801-PCH24MCA	Height Adjusting Chain Assembly	1
5	0802-DCTP-24	Disc Chain Tie Plate Link 24mm	1
6	0802-PCHB553	24mm Bolt Swivel Unit	1
7	0810-20-60	Chain Mt Arm 24mm Clevis	1
8	0211-1265	M12 x 65 8.8 zp Bolt	1
9	0221-NYL12	M12 Nyloc Nut	1
10	0232-HT13-8	Washer High Tensile 1 3/8"	1
11	0211-24120ST	M24 x 120 Short Thread 8.8 zp Bolt	3
12	0221-NYL24	M24 Nyloc Nut	3

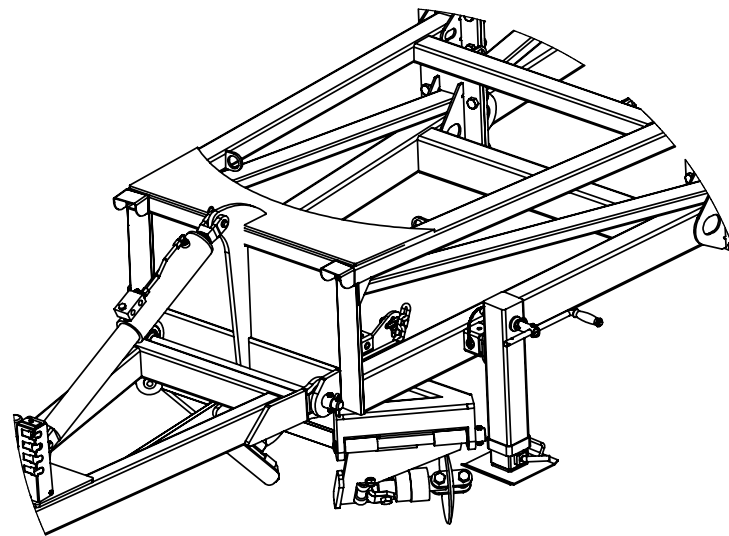
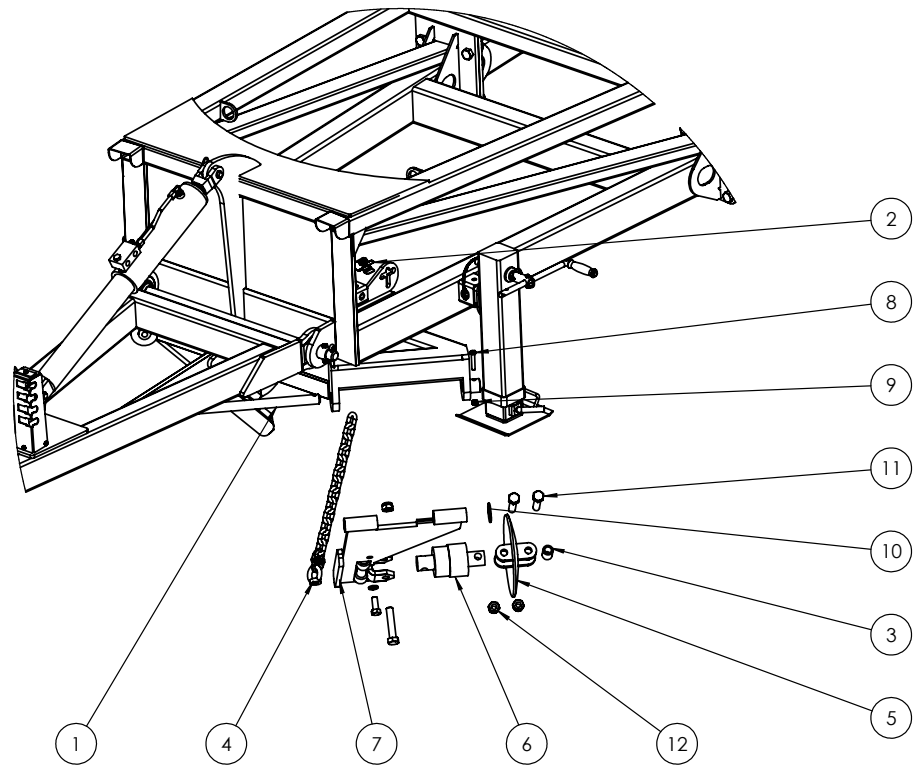

TRAVEL

ITEM NO.	PART NUMBER	DESCRIPTION	Qty
1	0801-10-51	Chain Mount Pivot Pin	1
2	0801-KE014	Height Adjustor Retaining Clip	1
3	0801-PCDCS55	Tie Plate Bush	1
4	0801-PCH24MCA	Height Adjusting Chain Assembly	1
5	0802-DCTP-24	Disc Chain Tie Plate Link 24mm	1
6	0802-PCHB553	24mm Bolt Swivel Unit	1
7	0810-20-60	Chain Mt Arm 24mm Clevis	1
8	0211-1265	M12 x 65 8.8 zp Bolt	1
9	0221-NYL12	M12 Nyloc Nut	1
10	0232-HT13-8	Washer High Tensile 1 3/8"	1
11	0211-24120ST	M24 x 120 Short Thread 8.8 zp Bolt	3
12	0221-NYL24	M24 Nyloc Nut	3

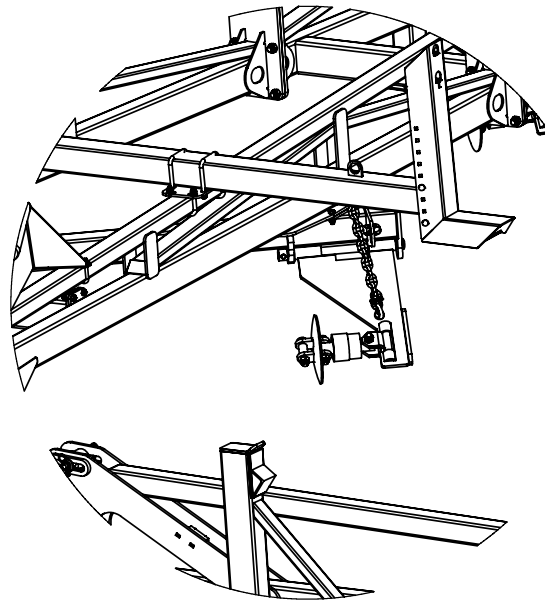
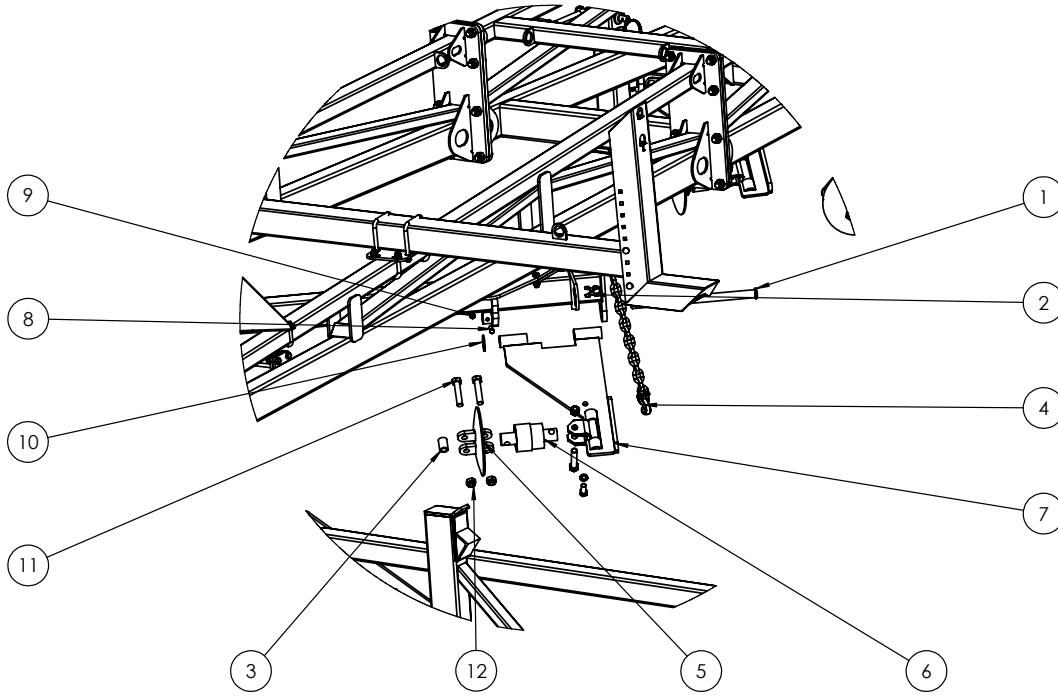

TRAVEL →

ITEM NO.	PART NUMBER	DESCRIPTION	Qty
1	0810-103F	Front Module Tension Body	1
2	0810-104-50-60	40/45° Module Tension Arm	1
3	0801-PCHTA-SB	Steel Spring Retaining Bush	1
4	0801-KE0307-1	Clevis Pin 25mm x 75mm	1
5	0801-XK9261S	20mm Compression Spring	1
6	0810-105	Module Tension Linkage	1
7	0801-10-S2L	Rigid Spring Locator	1
8	0801-10-110	Module Pivot Arm Bush	1
9	0113-MB 3550DX	35 ID x 50mm DX Bush	2
10	0211-20150	M20 x 150 8.8 zp Bolt	1
11	0221-NYL20	M20 Nyloc Nut	1
12	0232-HT11-4	Washer High Tensile 1 1/4"	1
13	0801-PCHTA-N6	1 1/4" 6 tpi ACME Lock Nut	2
14	0261-PINC550	Cotter Pin M5 x 50	1

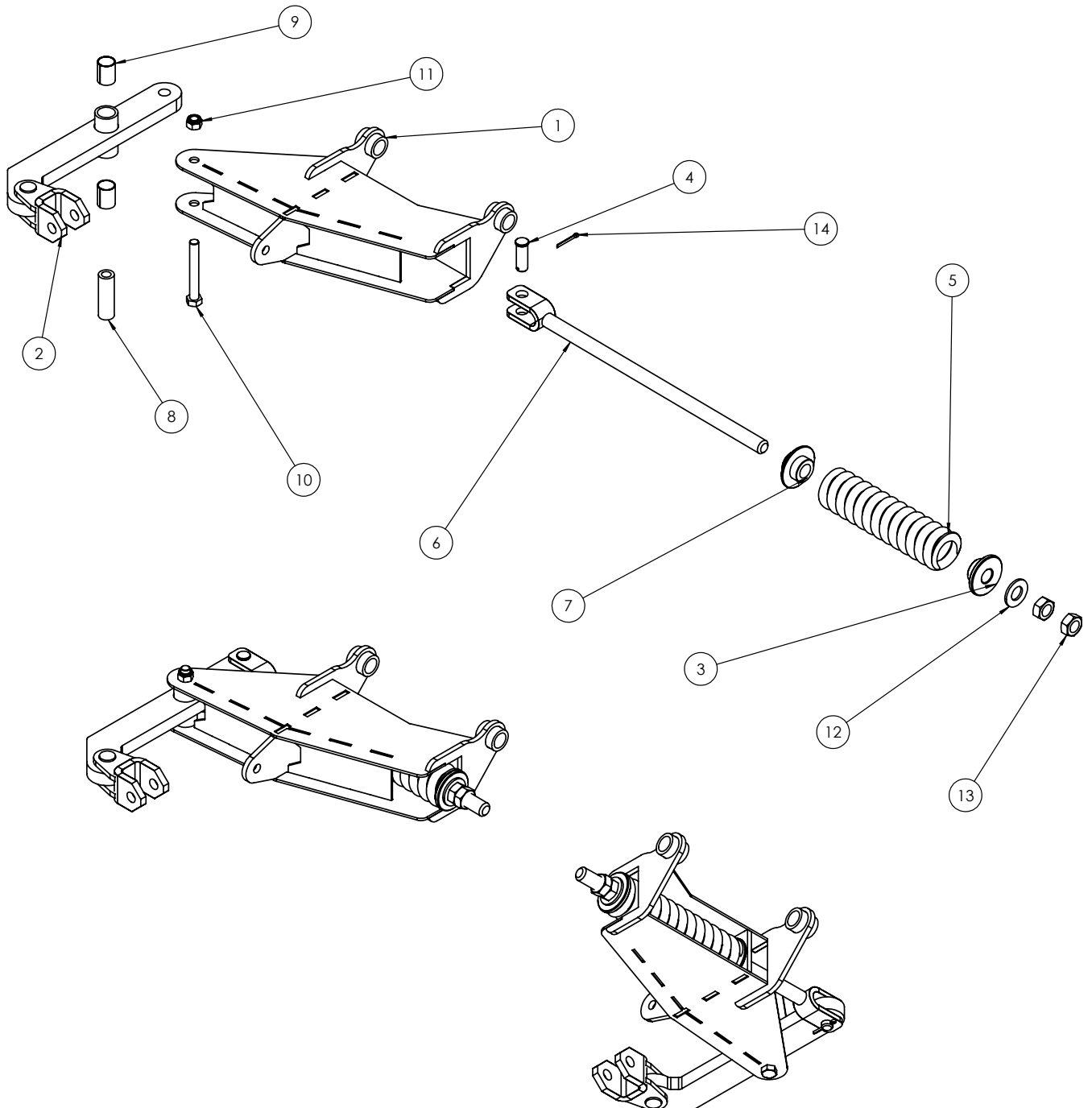

ITEM NO.	PART NUMBER	DESCRIPTION	Qty
1	0801-10-51	Chain Mount Pivot Pin	1
2	0801-KE014	Height Adjustor Retaining Clip	1
3	0801-PCDCS55	Tie Plate Bush	1
4	0801-PCH24MCA	Height Adjusting Chain Assembly	1
5	0802-DCTP-24	Disc Chain Tie Plate Link 24mm	1
6	0802-PCHB553	24mm Bolt Swivel Unit	1
7	0810-103FA-50-60	50-60" Front Module Tension Assembly	1
8	0211-1265	M12 x 65 8.8 zp Bolt	1
9	0221-NYL12	M12 Nyloc Nut	1
10	0232-HT13-8	Washer High Tensile 1 3/8"	1
11	0211-24120ST	M24 x 120 Short Thread 8.8 zp Bolt	3
12	0221-NYL24	M24 Nyloc Nut	3

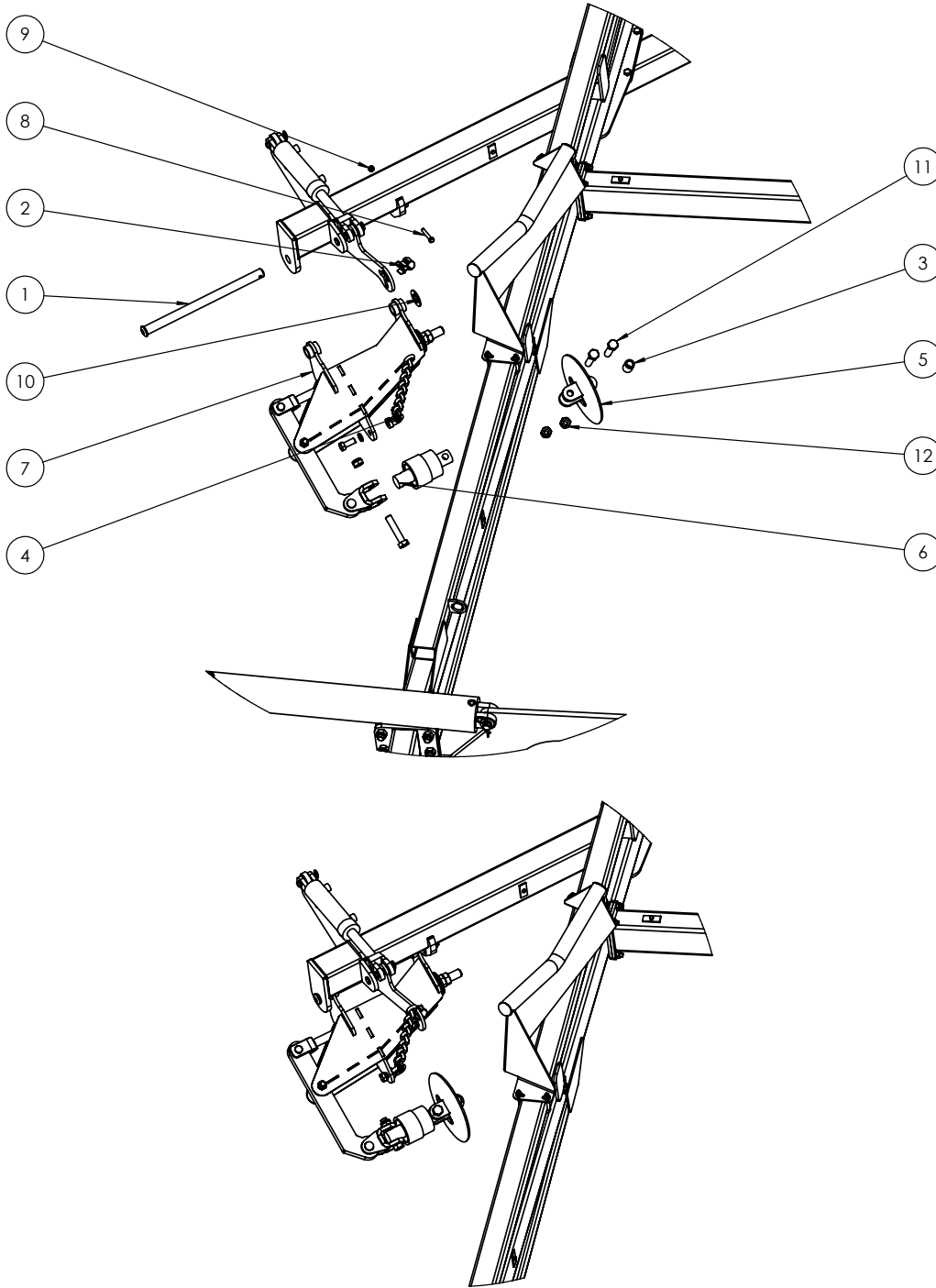

TRAVEL

ITEM NO.	PART NUMBER	DESCRIPTION	Qty
1	0801-10-51	Chain Mount Pivot Pin	1
2	0211-1265	M12 x 65 8.8 zp Bolt	1
3	0221-NYL12	M12 Nyloc Nut	1
4	0232-HT13-8	Washer High Tensile 1 3/8"	1
5	0801-KE014	Height Adjustor Retaining Clip	1
6	0801-PCDCS55	Tie Plate Bush	1
7	0801-PCH24MCA	Height Adjusting Chain Assembly	1
8	0802-DCTP-24	Disc Chain Tie Plate Link 24mm	1
9	0802-PCHB553	24mm Bolt Swivel Unit	1
10	0810-33-60	Reducing Chain Mount Arm 24mm Clevis	1
11	0211-24120ST	M24 x 120 Short Thread 8.8 zp Bolt	3
12	0221-NYL24	M24 Nyloc Nut	3

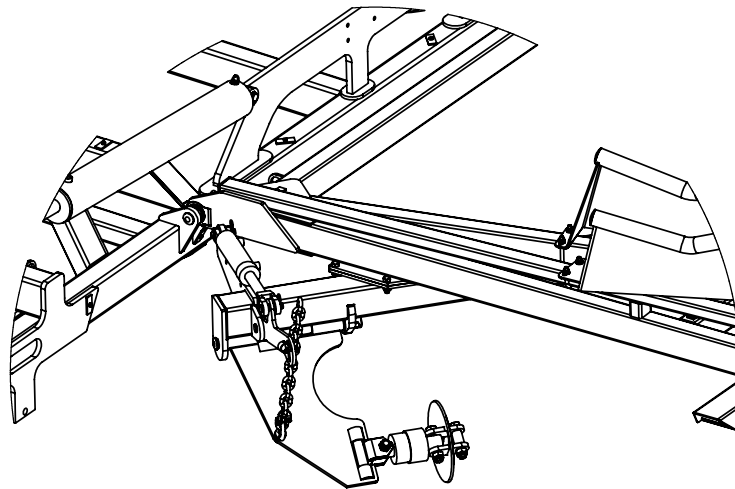
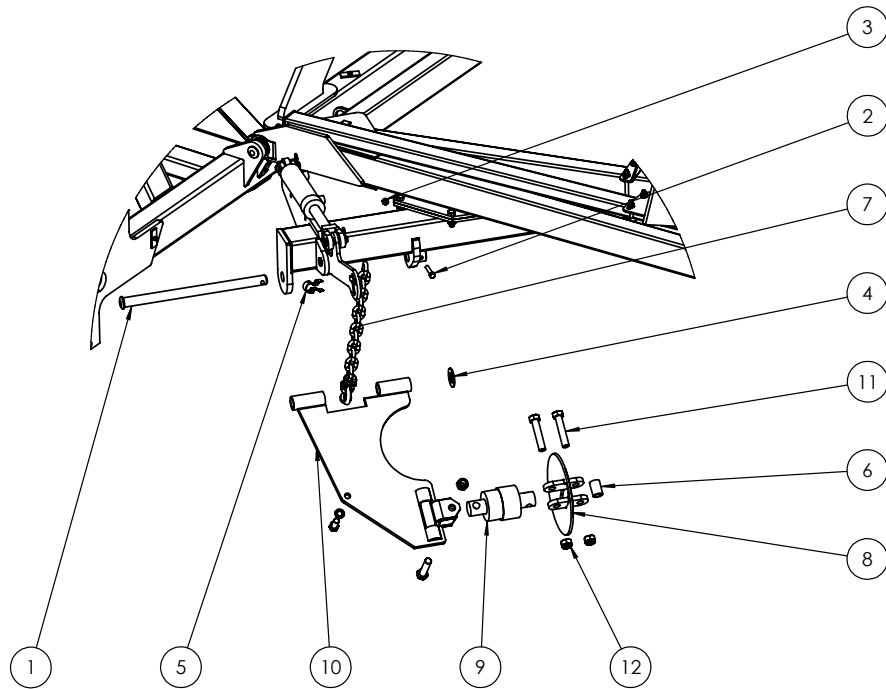

← TRAVEL

ITEM NO.	PART NUMBER	DESCRIPTION	Qty
1	0810-103R	Rear Module Tension Body	1
2	0810-104-50-60	40/45' Module Tension Arm	1
3	0801-PCHTA-SB	Steel Spring Retaining Bush	1
4	0801-KE0307-1	Clevis Pin 25mm x 75mm	1
5	0801-XK9261S	20mm Compression Spring	1
6	0810-105	Module Tension Linkage	1
7	0801-10-S2L	Rigid Spring Locator	1
8	0801-10-110	Module Pivot Arm Bush	1
9	0113-MB 3550DX	35 ID x 50mm DX Bush	2
10	0261-PINC550	Cotter Pin M5 x 50	1
11	0232-HT11-4	Washer High Tensile 1 1/4"	1
12	0801-PCHTA-N6	1 1/4" 6 tpi ACME Lock Nut	2
13	0211-20150	M20 x 150 8.8 zp Bolt	1
14	0221-NYL20	M20 Nyloc Nut	1

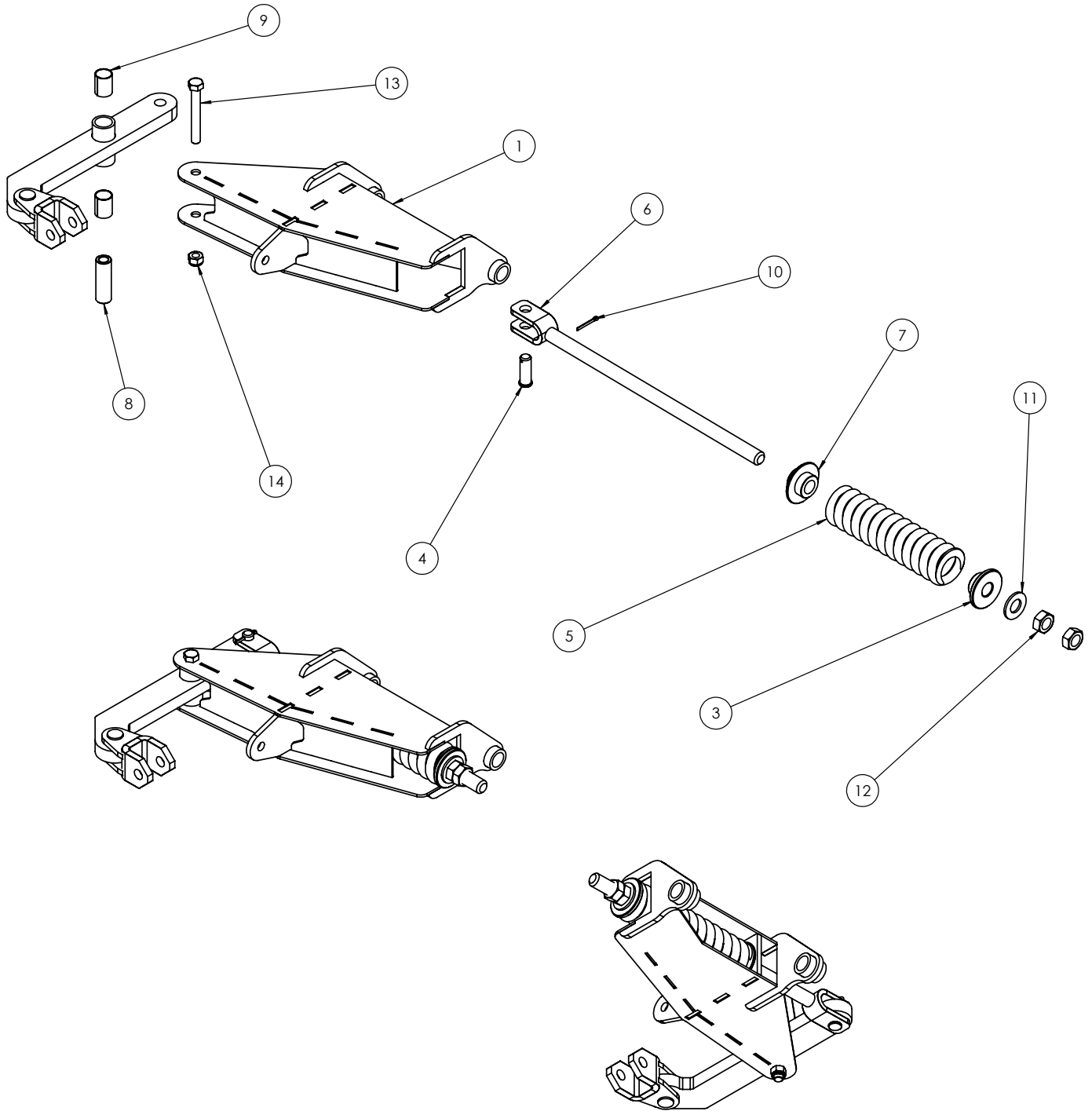

ITEM NO.	PART NUMBER	DESCRIPTION	Qty
1	0211-1265	M12 x 65 8.8 zp Bolt	1
2	0221-NYL12	M12 Nyloc Nut	1
3	0232-HT13-8	Washer High Tensile 1 3/8"	1
4	0801-10-51	Chain Mount Pivot Pin	1
5	0801-KE014	Height Adjustor Retaining Clip	1
6	0801-PCDCS55	Tie Plate Bush	1
7	0801-PCH24MCA	Height Adjusting Chain Assembly	1
8	0802-DCTP-24	Disc Chain Tie Plate Link 24mm	1
9	0802-PCHB553	24mm Bolt Swivel Unit	1
10	0810-103RA-50-60	50-60' Rear Module Tension Assembly	1
11	0211-24120ST	M24 x 120 Short Thread 8.8 zp Bolt	3
12	0221-NYL24	M24 Nyloc Nut	3

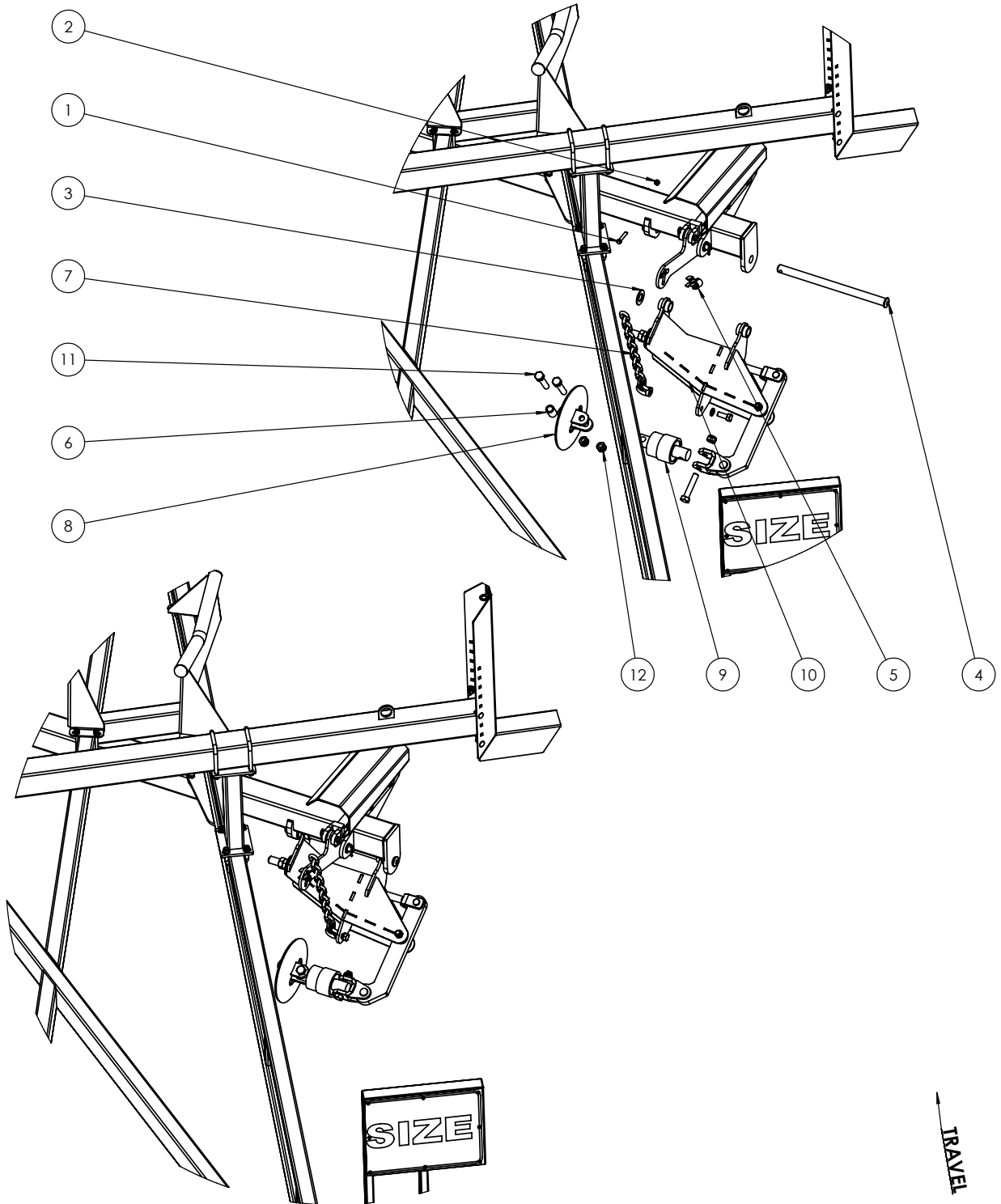

ITEM NO.	PART NUMBER	DESCRIPTION	Qty
1	0211-1265	M12 x 65 8.8 zp Bolt	1
2	0221-NYL12	M12 Nyloc Nut	1
3	0232-HT13-8	Washer High Tensile 1 3/8"	1
4	0801-10-51	Chain Mount Pivot Pin	1
5	0801-KE014	Height Adjustor Retaining Clip	1
6	0801-PCDCS55	Tie Plate Bush	1
7	0801-PCH24MCA	Height Adjustor Chain Assembly	1
8	0802-DCTP-24	Disc Chain Tie Plate Link 24mm	1
9	0802-PCHB553	24mm Bolt Swivel Unit	1
10	0810-20-60	Chain Mt Arm 24mm Clevis	1
11	0211-24120ST	M24 x 120 Short Thread 8.8 zp Bolt	3
12	0221-NYL24	M24 Nyloc Nut	3

**PLEASE REFER TO
ASSEMBLY UPDATE 043
IN THE BACK OF THE
MANUAL**

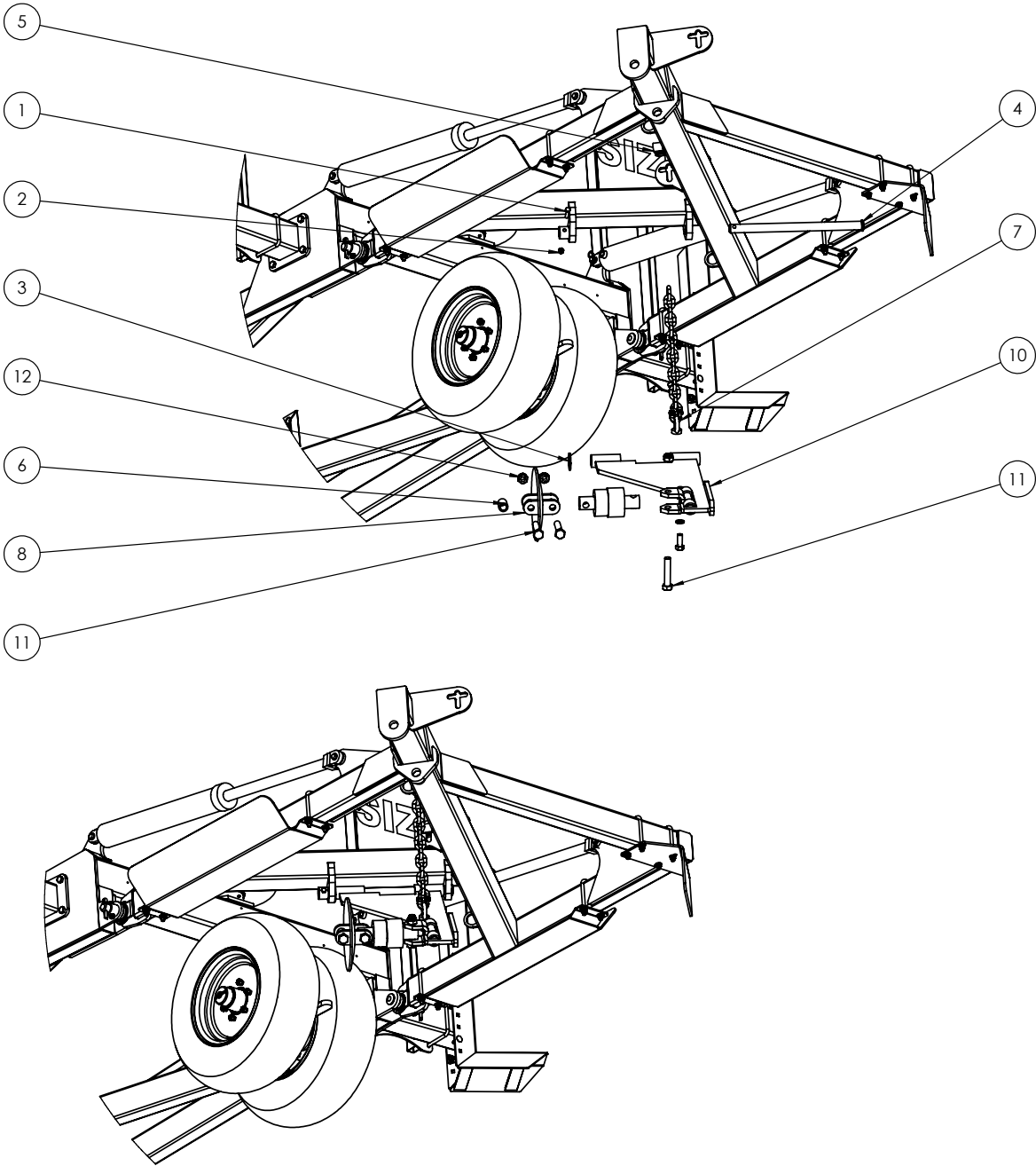

TRAVEL →

ITEM NO.	PART NUMBER	DESCRIPTION	Qty
1	0211-1265	M12 x 65 8.8 zp Bolt	1
2	0221-NYL12	M12 Nyloc Nut	1
3	0232-HT13-8	Washer High Tensile 1 3/8"	1
4	0801-10-51	Chain Mount Pivot Pin	1
5	0801-KE014	Height Adjustor Retaining Clip	1
6	0801-PCDCS55	Tie Plate Bush	1
7	0801-PCH24MCA	Height Adjusting Chain Assembly	1
8	0802-DCTP-24	Disc Chain Tie Plate Link 24mm	1
9	0802-PCHB553	24mm Bolt Swivel Unit	1
10	0810-20-60	Chain Mt Arm 24mm Clevis	1
11	0211-24120ST	M24 x 120 Short Thread 8.8 zp Bolt	3
12	0221-NYL24	M24 Nyloc Nut	3

**PLEASE REFER TO
ASSEMBLY UPDATE 043
IN THE BACK OF THE
MANUAL**

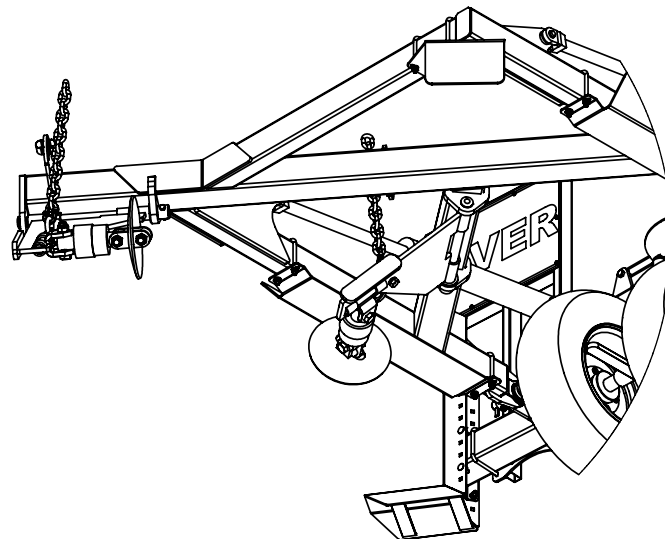
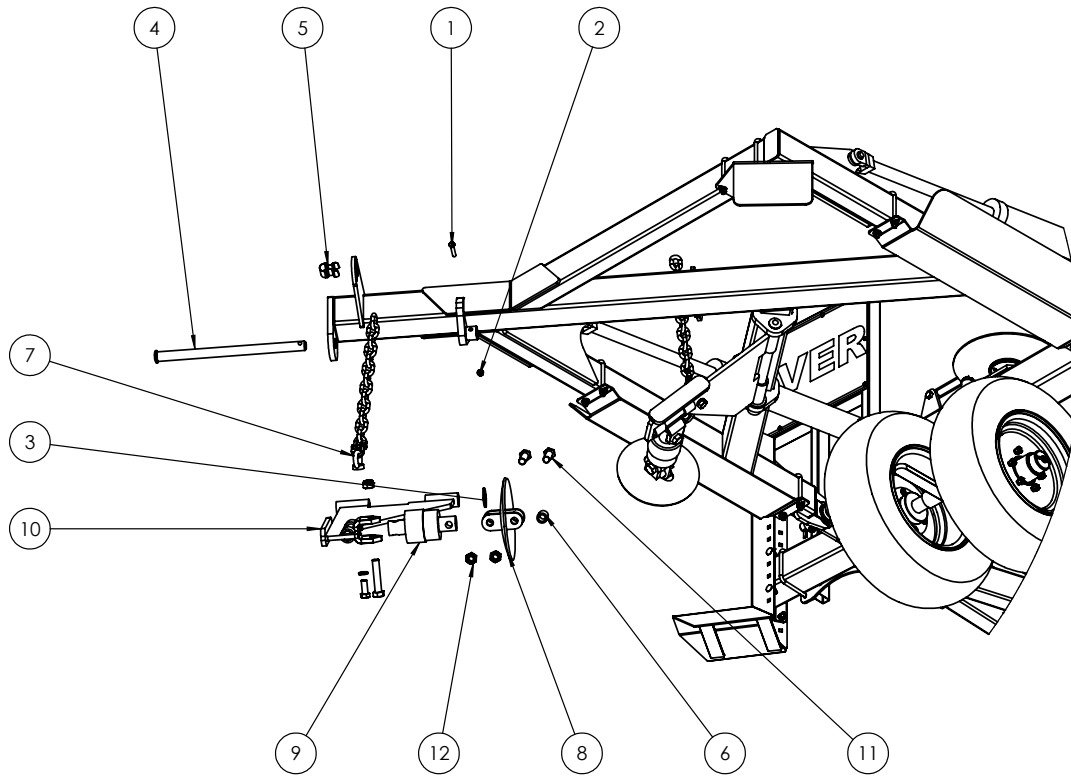

TRAVEL →

ITEM NO.	PART NUMBER	DESCRIPTION	Qty
1	0211-M620MZPHTF	M6 x 20 Trilobe self tapping ScREW	3
2	0211-24120ST	M24 x 120 Short Thread 8.8 zp Bolt	1
3	0221-NYL24	M24 Nyloc Nut	1
4	0492-OPMAN	Diamond Harrow Operating Instruction Manual	1
5	0801-OMC-1	Operator Manual Cannister	1
6	0802-GW1 3-4	Gear Wrench 1 3/4"	1
7	0802-PCHB553	24mm Bolt Swivel Unit	1

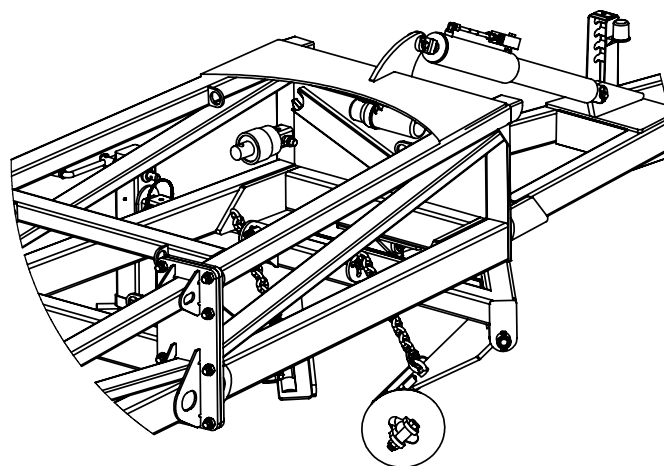
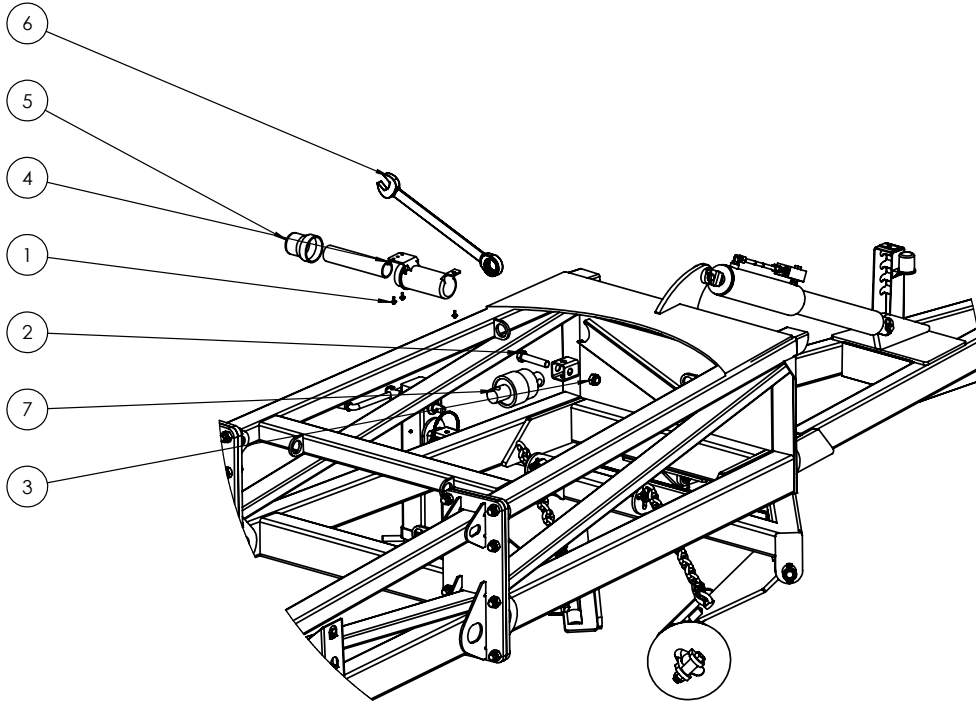

TRAVEL

ITEM NO.	PART NUMBER	DESCRIPTION	Qty
1	0810-34LB	Light Bracket	1
2	0412-85940	Indicator Lamp	1
3	0211-10180	M10 x 180 zp Bolt	4
4	0221-NYL10	M10 Nyloc Nut	4

This Step not applicable for Domestic machines

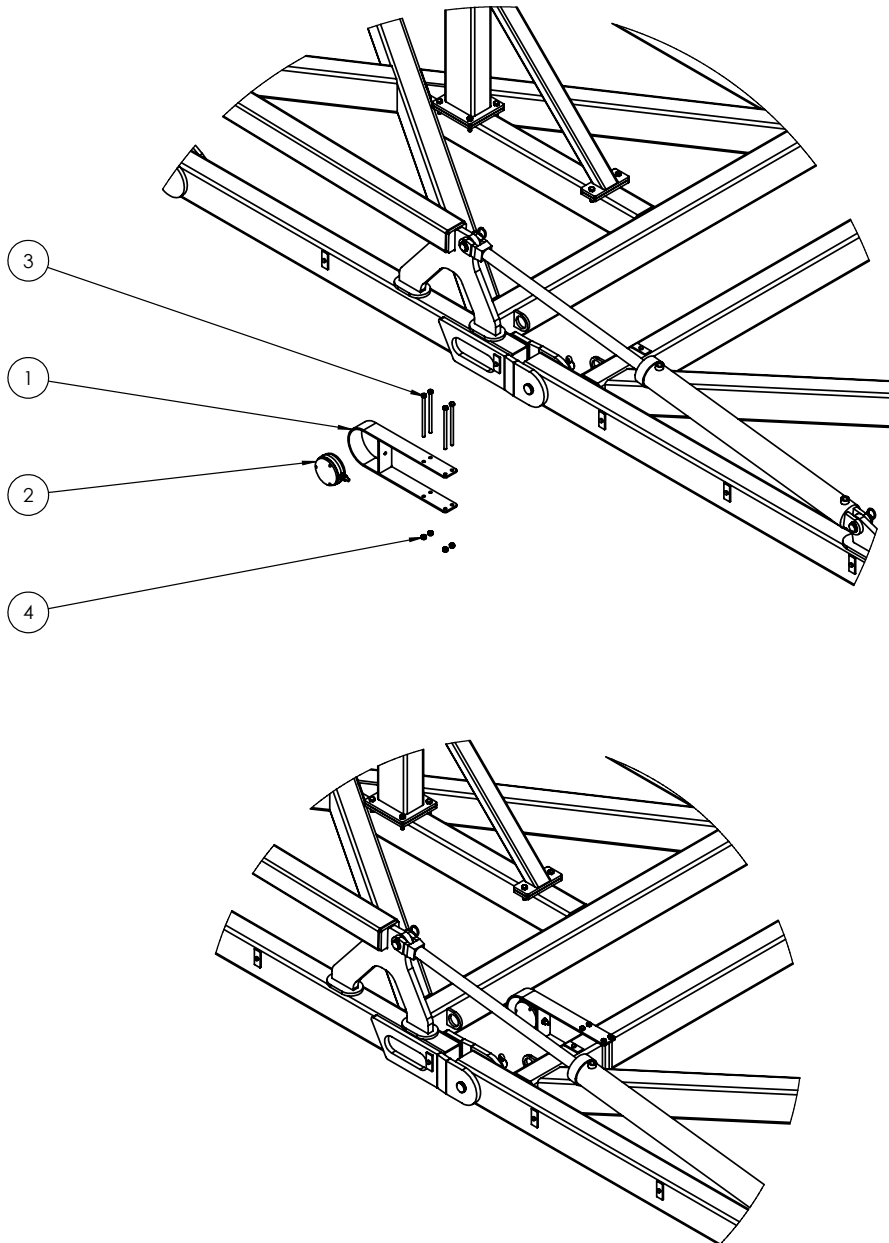

TRAVEL →

ITEM NO.	PART NUMBER	DESCRIPTION	Qty
1	0810-34LB	Light Bracket	1
2	0412-85940	Indicator Lamp	1
3	0211-10180	M10 x 180 8.8 zp Bolt	4
4	0221-NYL10	M10 Nyloc Nut	4

This Step not applicable for Domestic machines

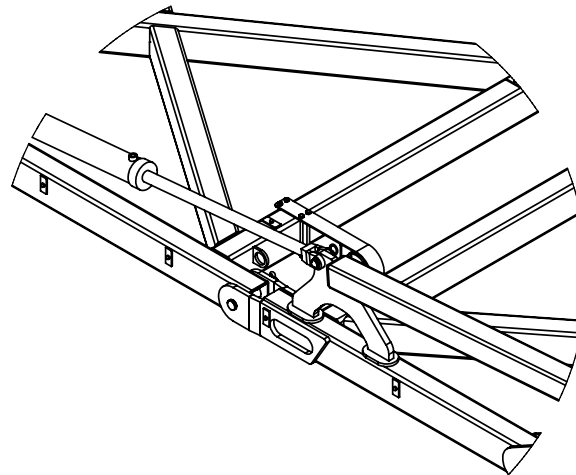
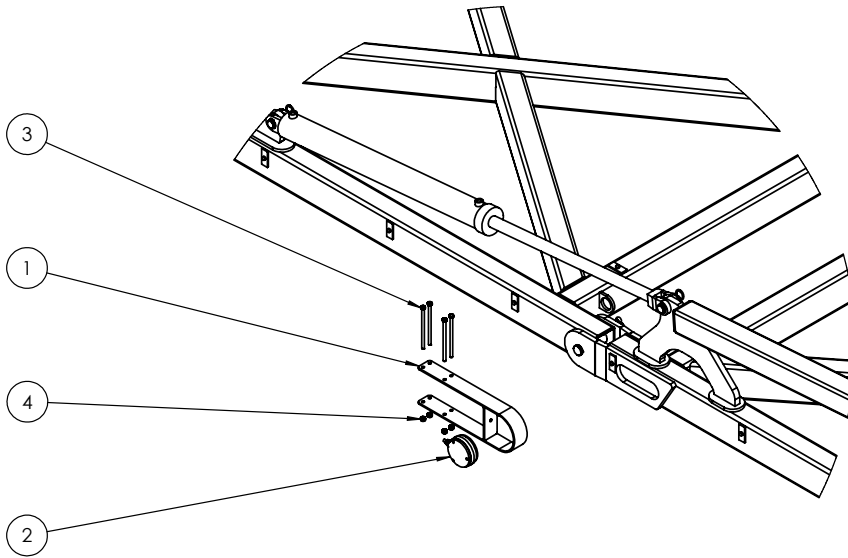

TRAVEL

ITEM NO.	PART NUMBER	DESCRIPTION	Qty
1	0800-194.1	US Tail Light Bracket	2
2	0800-195.1	SMV Sign Bracket	1
3	0801-FBSMVTUF	Slow Moving Vehical Sign	1
4	0412-53101RG	110RM Rubber Grommet	2
5	0412-LED110RM	LED Stop Tail Lamp	2
6	0211-M620MZPHTF	M6 x 20 Trilobe self tapping ScREW	8

This Step not applicable for Domestic machines

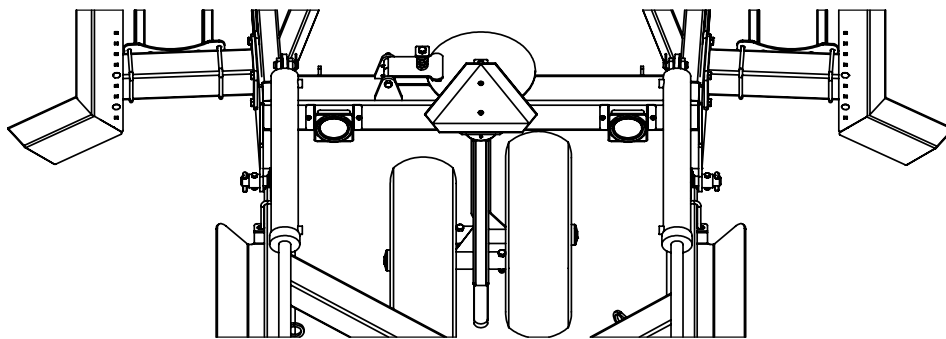
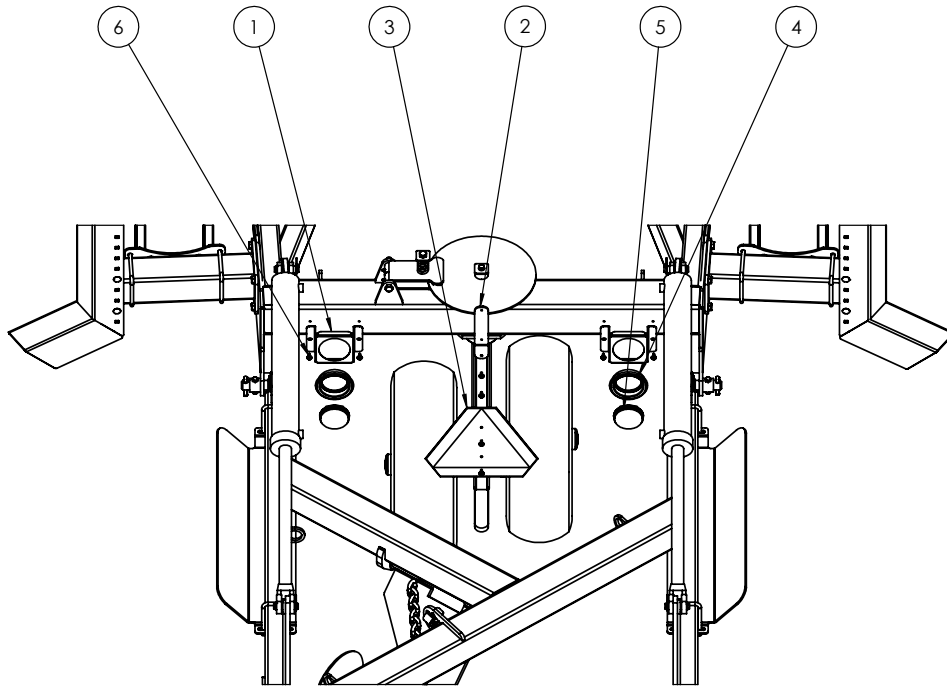

TRAVEL →

ITEM NO.	PART NUMBER	DESCRIPTION	Qty
1	0800-212.1	Cylinder Safety Stop	1
2	0511-PINLOOPSQ863	Square Loop Pin M8 x 63	1

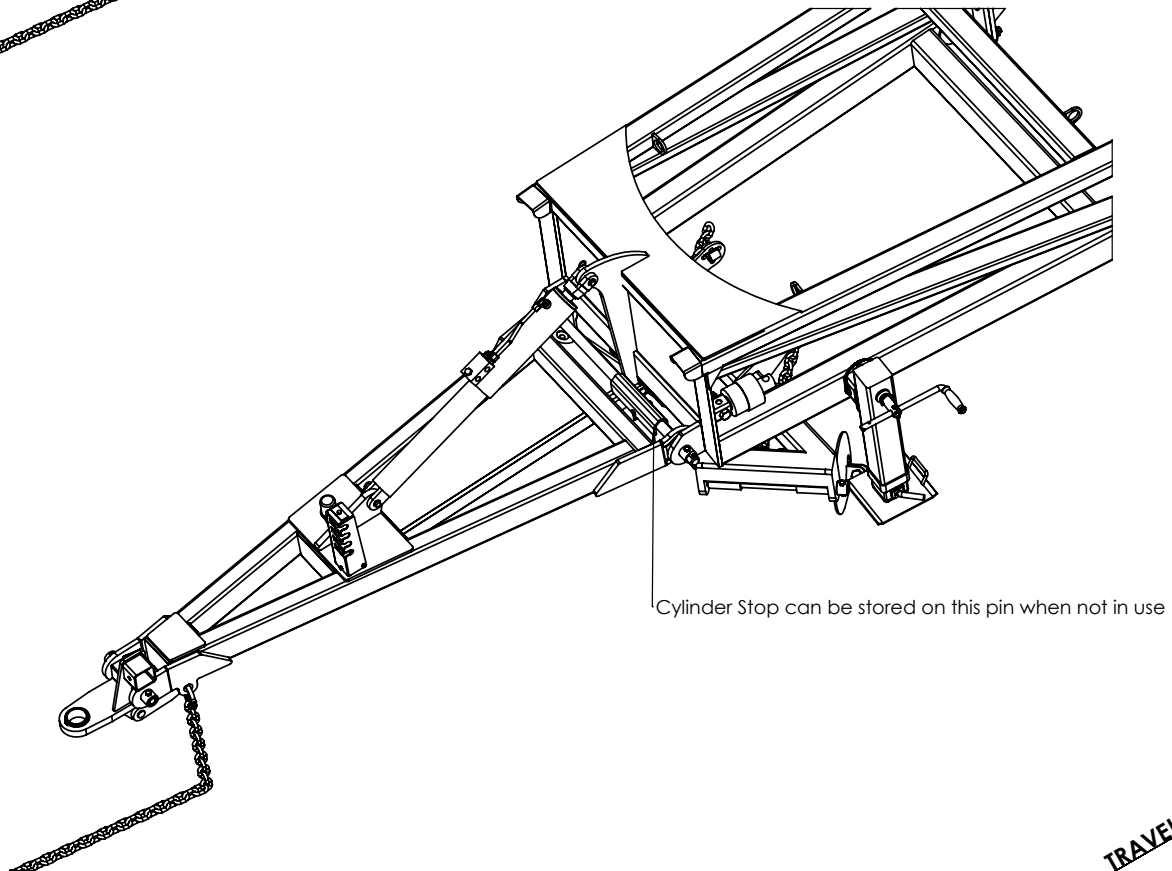
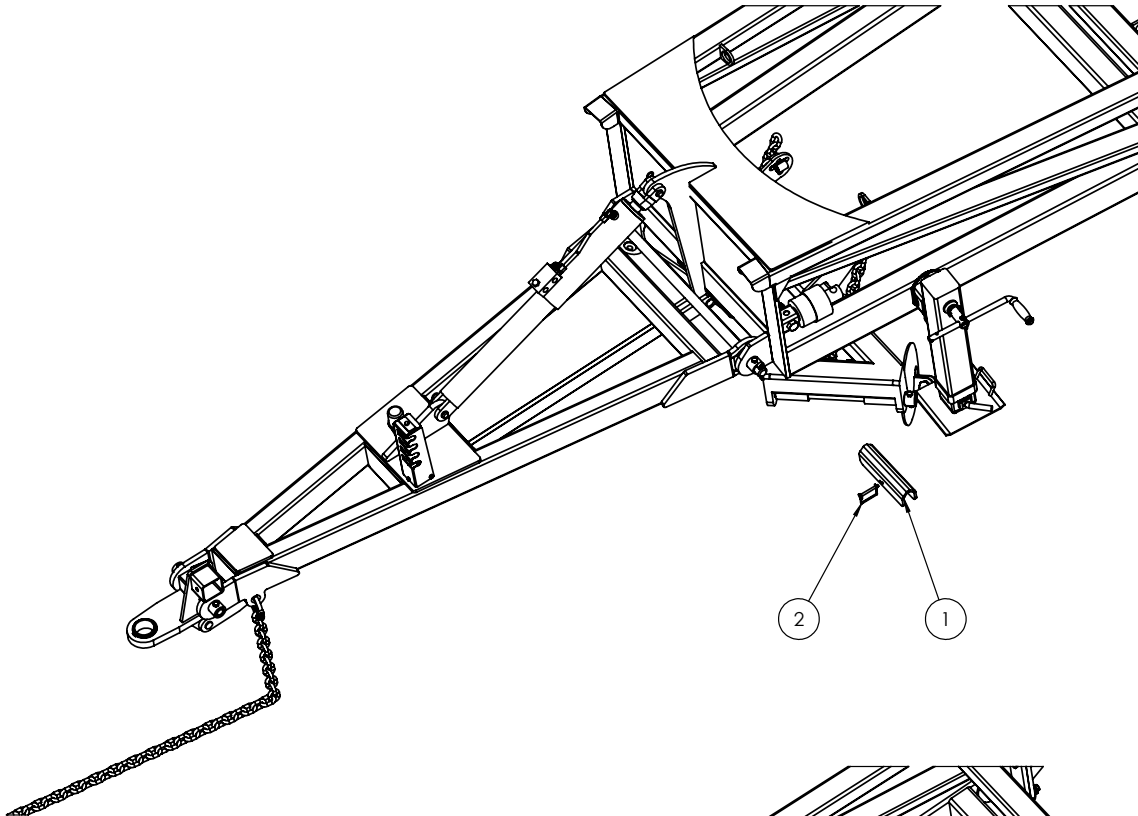

ITEM NO.	PART NUMBER	DESCRIPTION	Qty
1	0802-SV688712	3 Stage Kickdown Sequence Valve	1
2	0231-F10	M10 zp Flat Washer	3
3	0231-S10	M10 zp Spring Washer	3
4	0211-1040	M10 x 40 8.8 zp Bolt	3

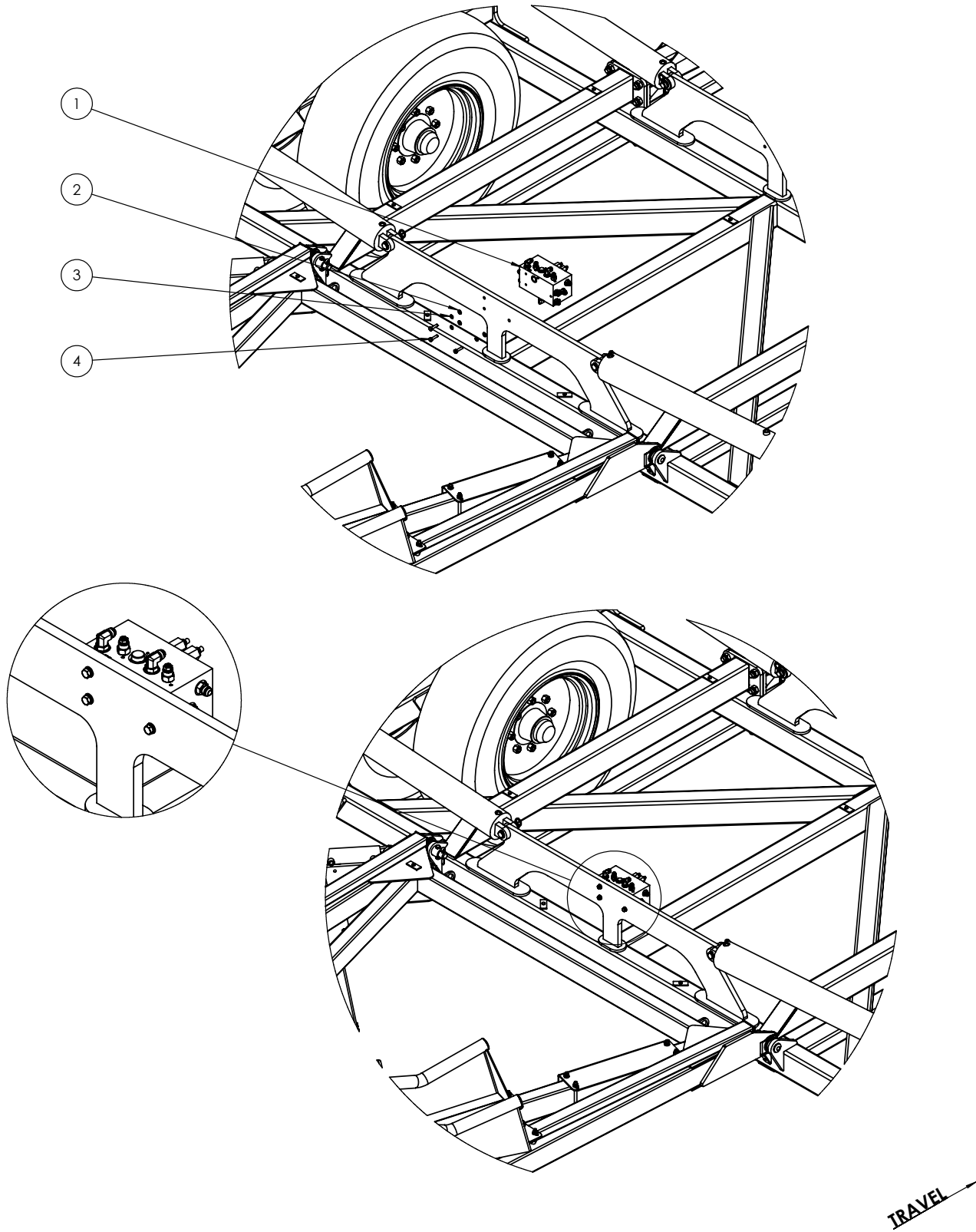

ITEM NO.	PART NUMBER	DESCRIPTION	Qty
1	0803-60CT-FL&R	60CT Front Chain	2
2	0803-60CT-LHR	60CT Left Hand Rear Chain	1
3	0803-60CT-MOD	60CT Module Chain	2
4	0803-60CT-RHR	60CT Right Hand Rear Chain	1

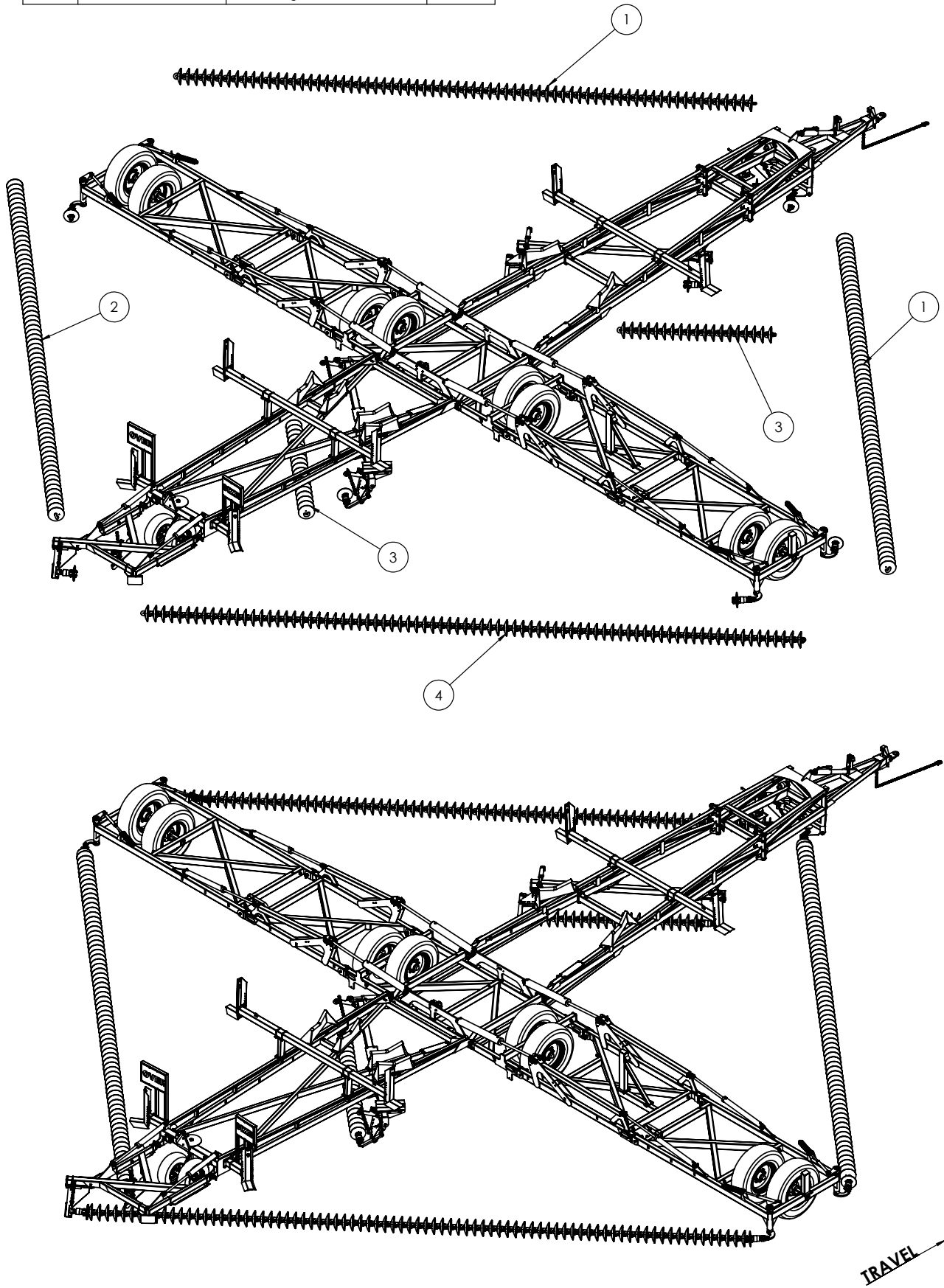

Section 3

Hydraulics set up

Charging hydraulic system



Before folding the machine for the first time, ensure all hydraulic cylinders are charged with oil.

To do this, run the hydraulics through the unfold sequence until the outer wings are straight and the center cylinders are centered in the slots. (It may take a few minutes for the cylinders to charge completely).

Failure to do this could result in severe personal injury and/or damage to the machine.

Cylinders NOT charged

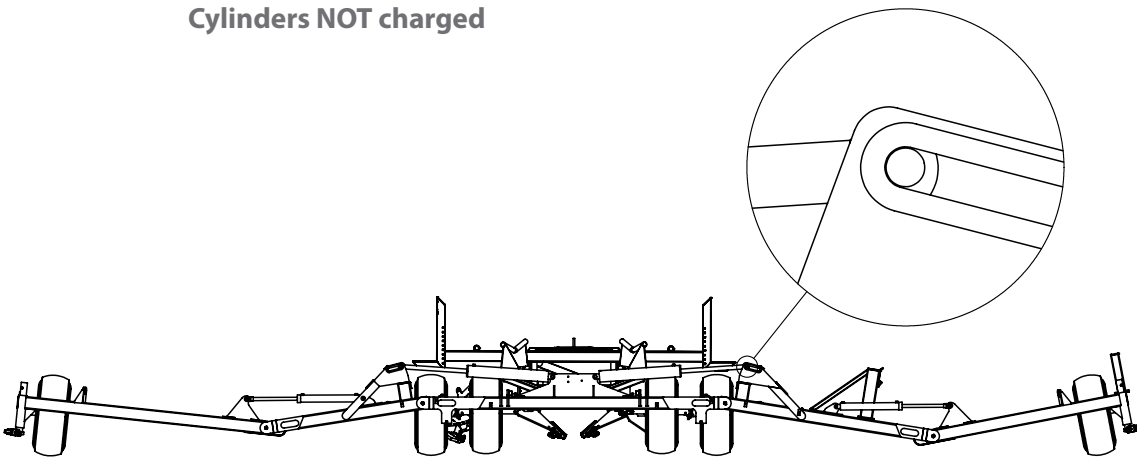

Cylinders charged

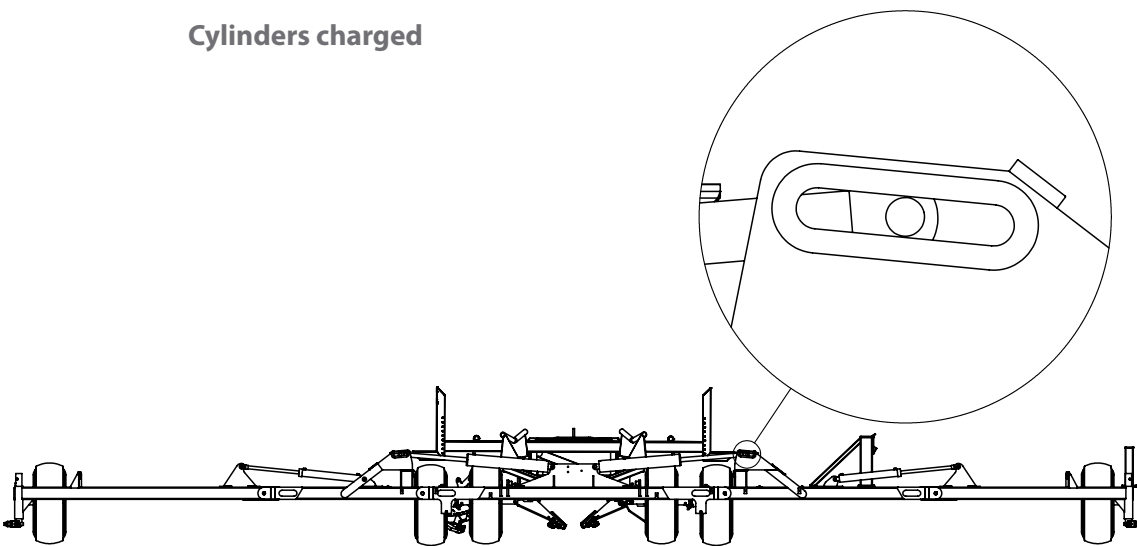

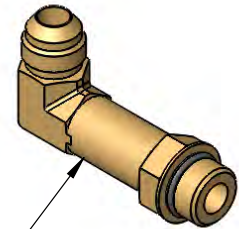

0323-S12-1212

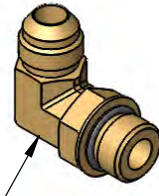

0323-S91-1212

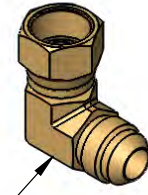

0323-S15-1212



0323-S71-0812



0323-S74-0812



0323-S88-1212



0323-S90

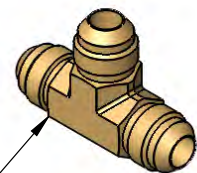

0324-S19-121212

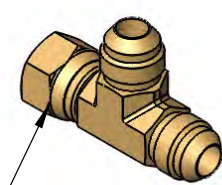

0324-S67-121212



0324-S92-121212

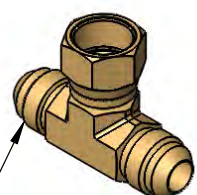

0324-S68-121212



0325-R91-08M

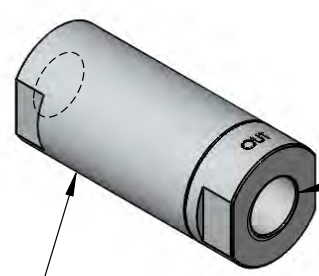

0343-924001261

Note: Fit this end to valve block

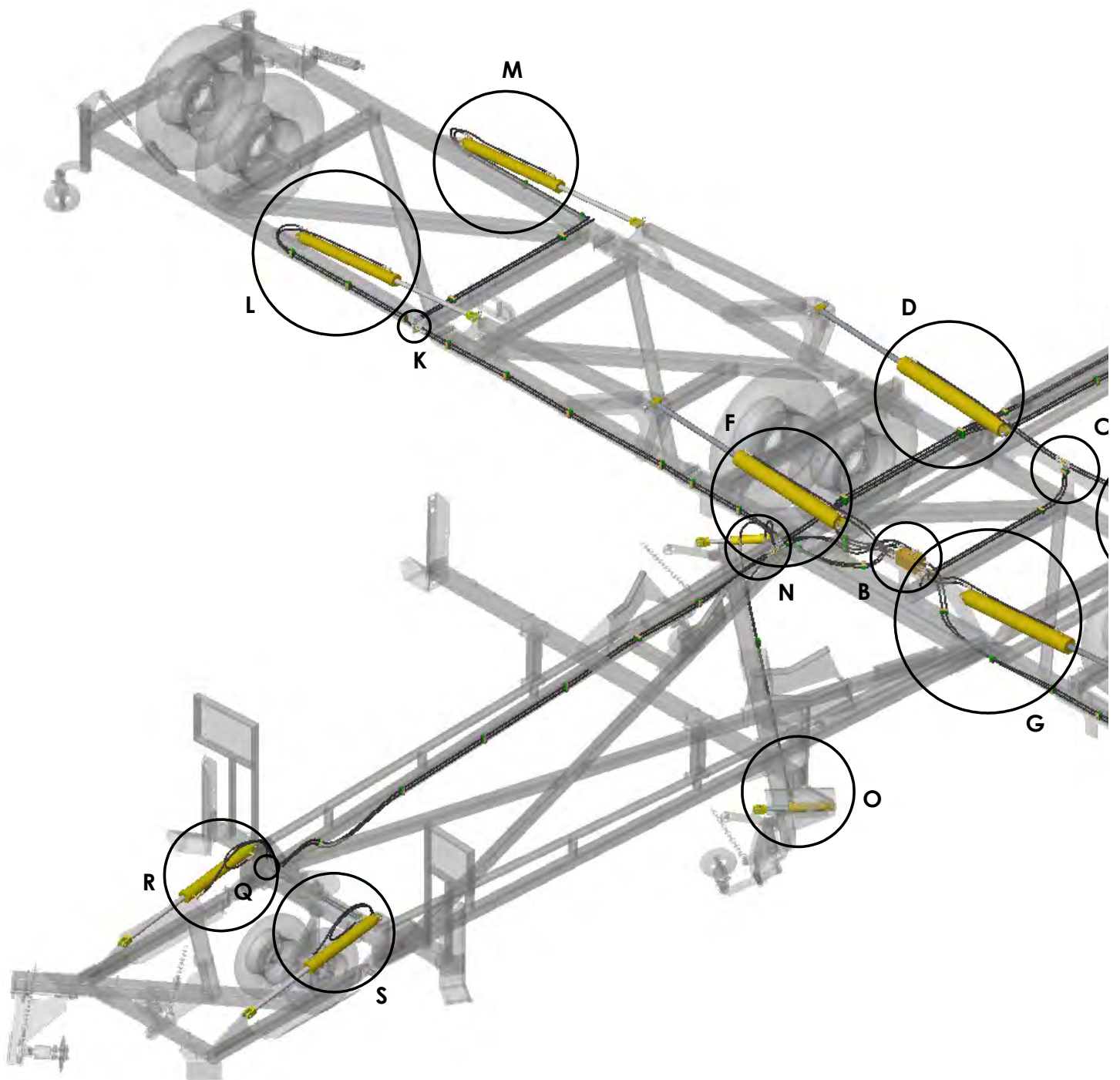

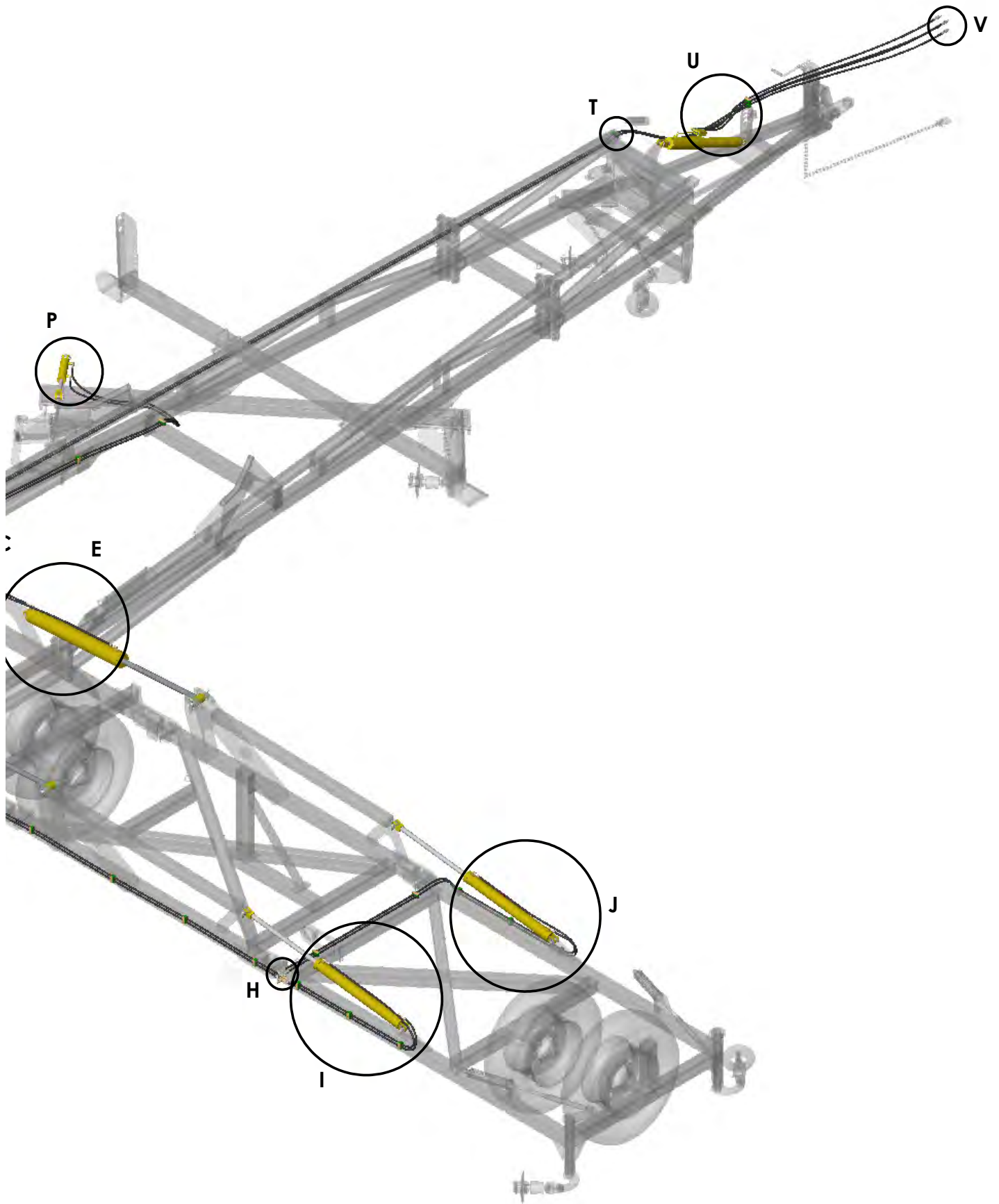

**PLEASE REFER TO
ASSEMBLY UPDATE 020
IN THE BACK OF THE
MANUAL**

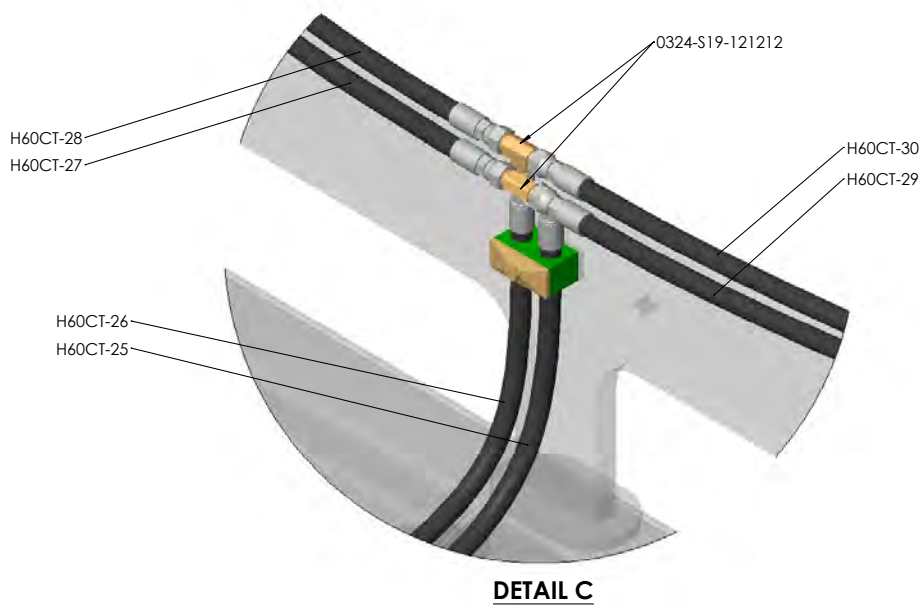
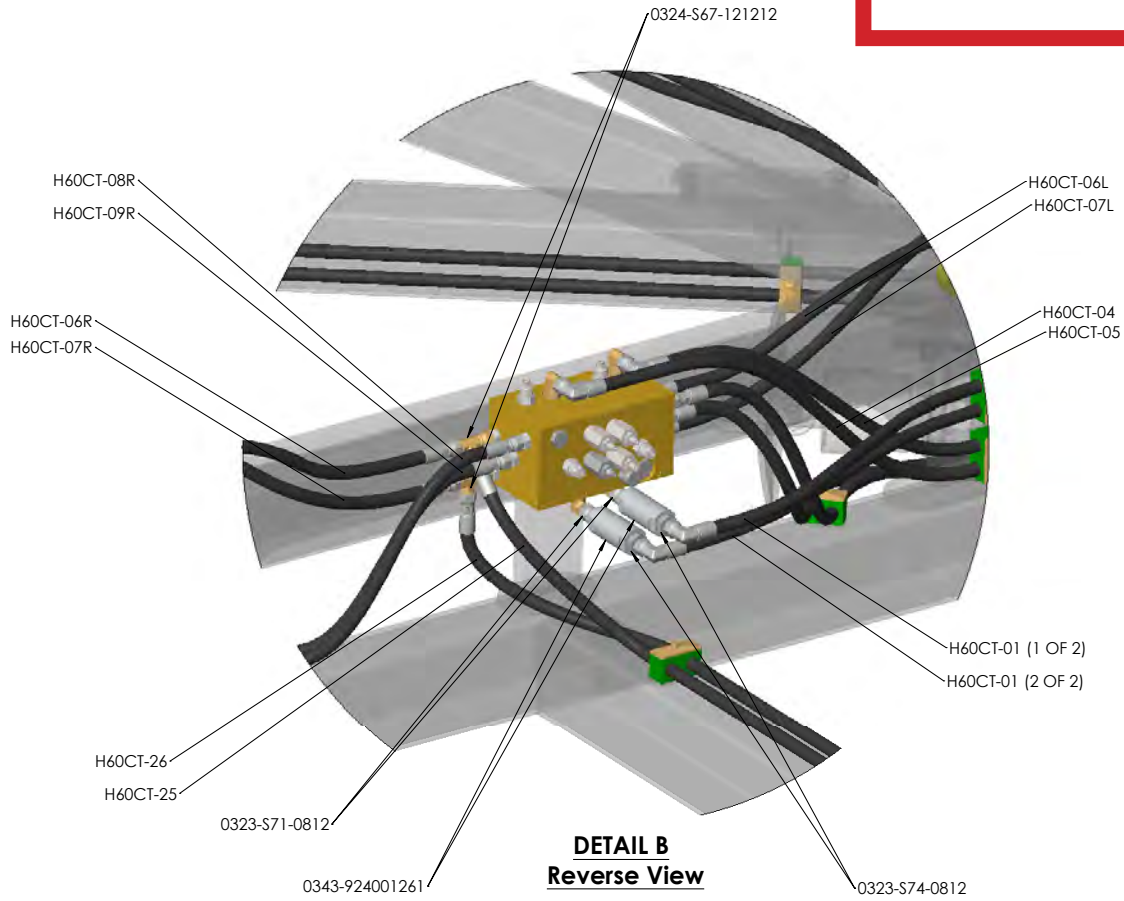

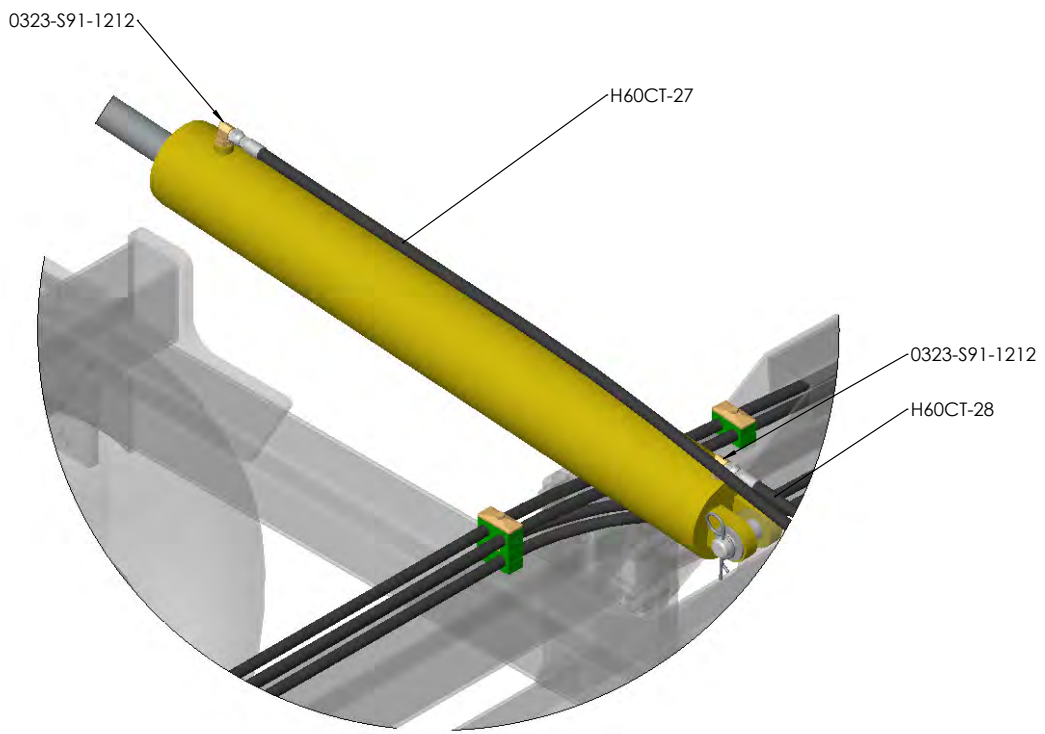

DETAIL D

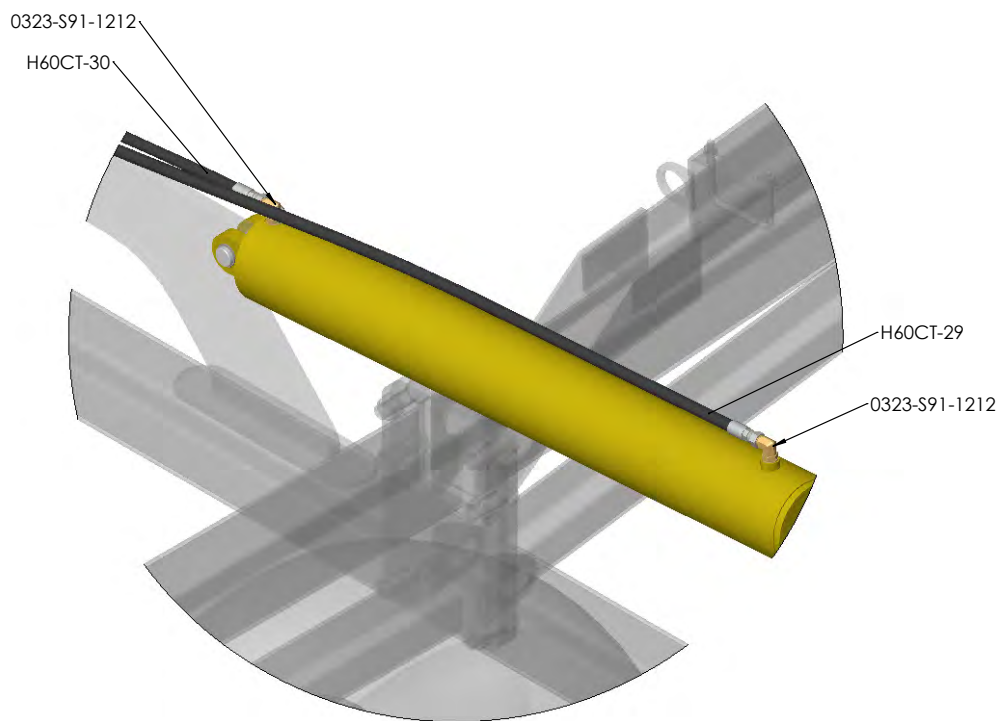

DETAIL E

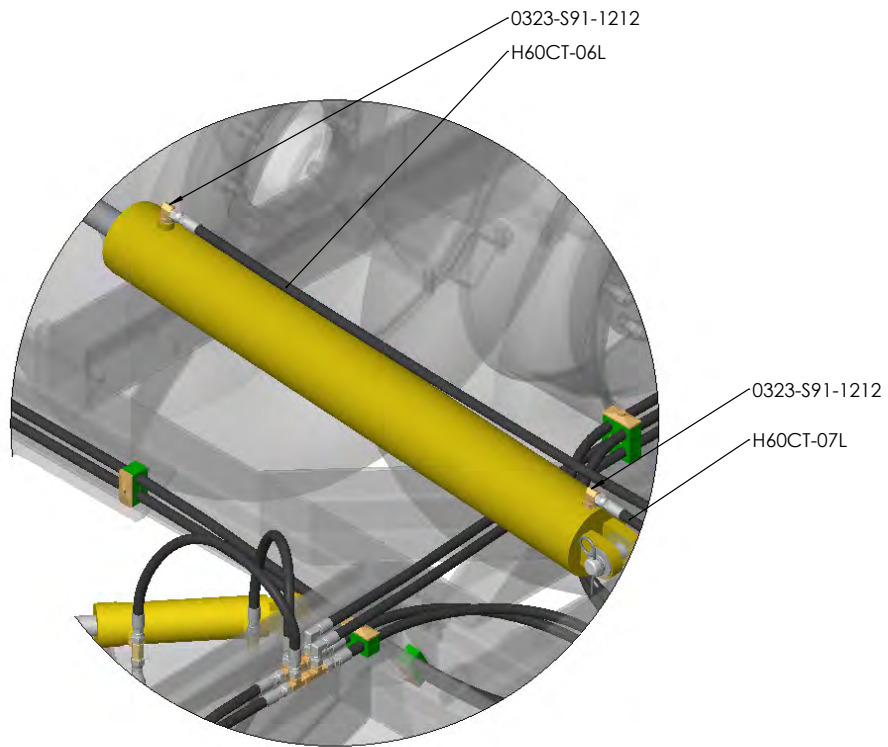

DETAIL F

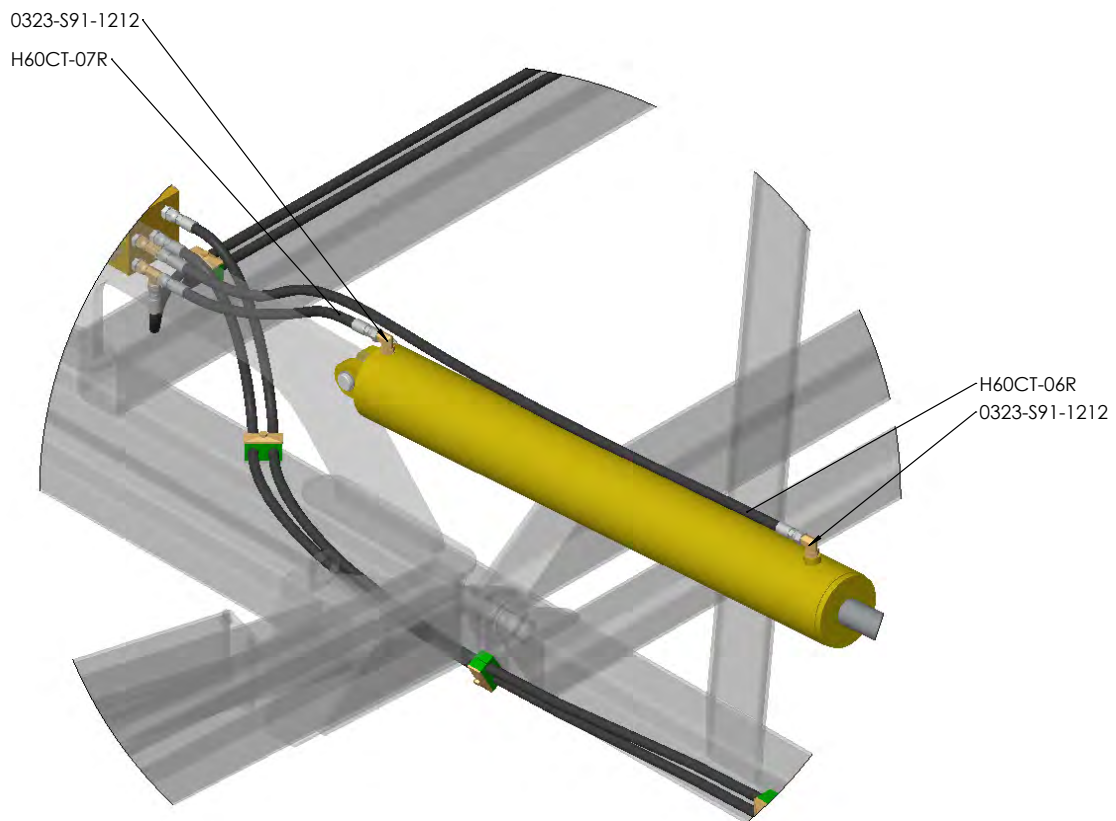

DETAIL G

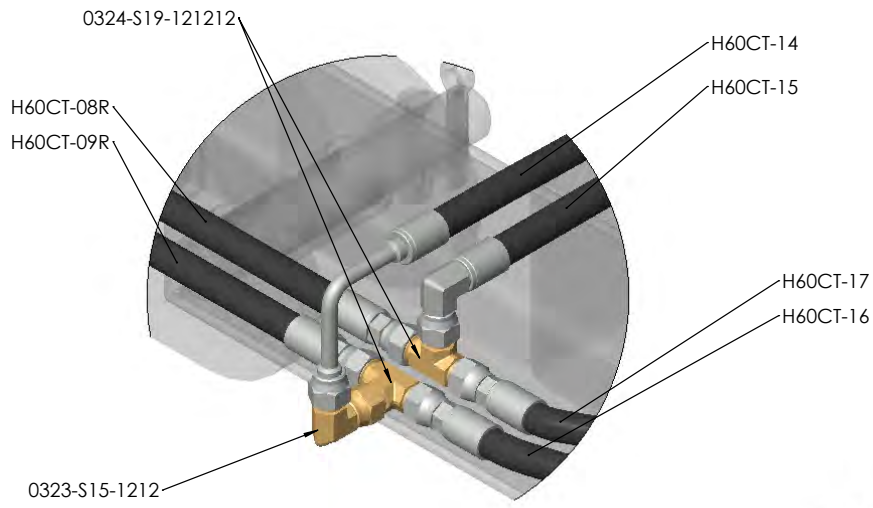

DETAIL H

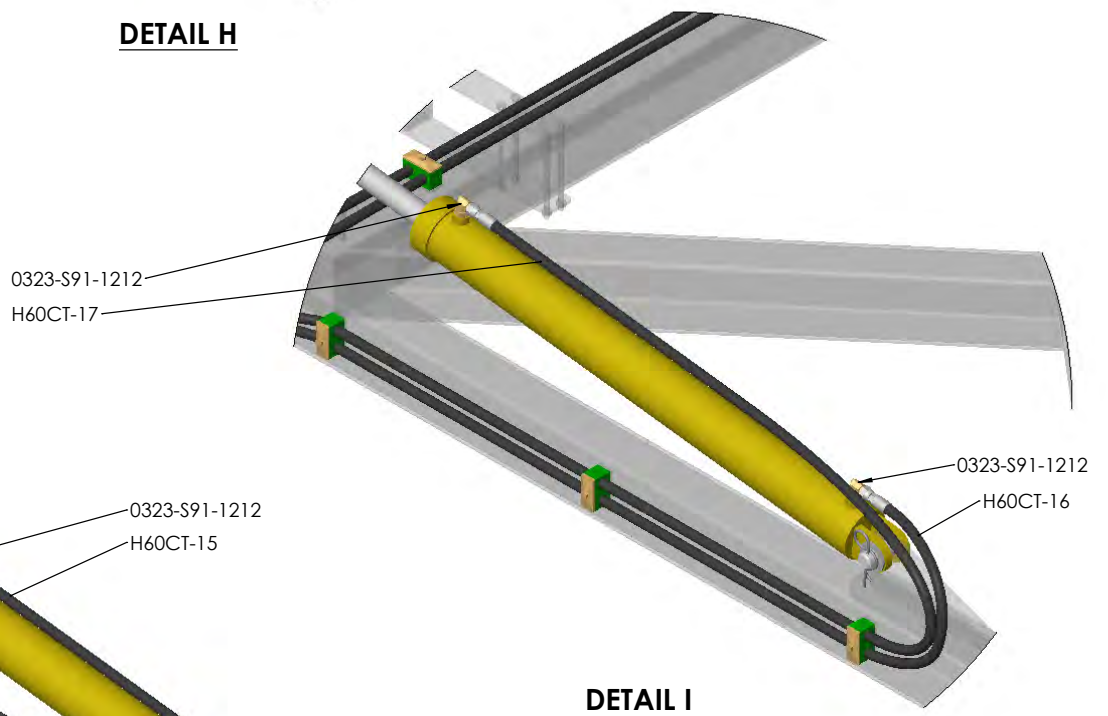

DETAIL I

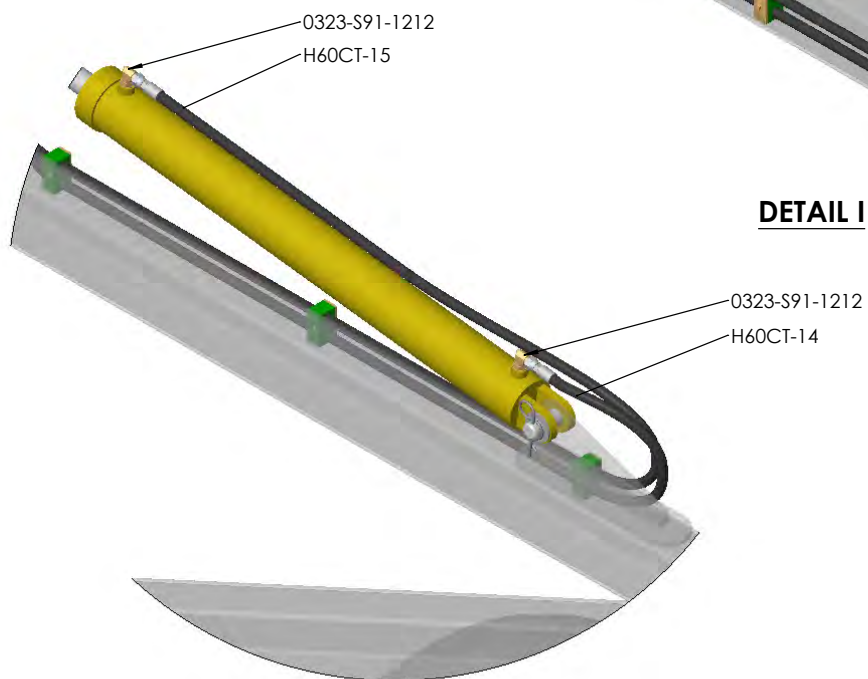

DETAIL J

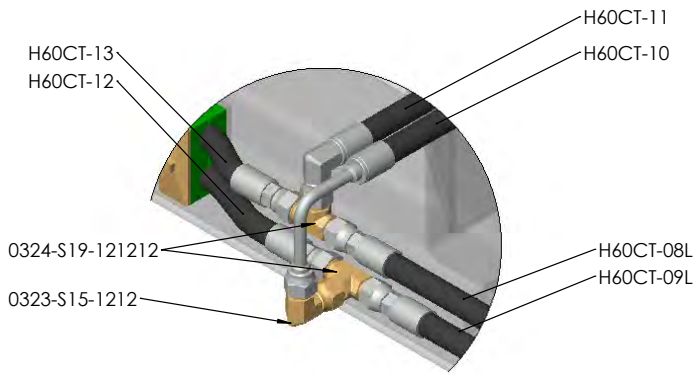

DETAIL K

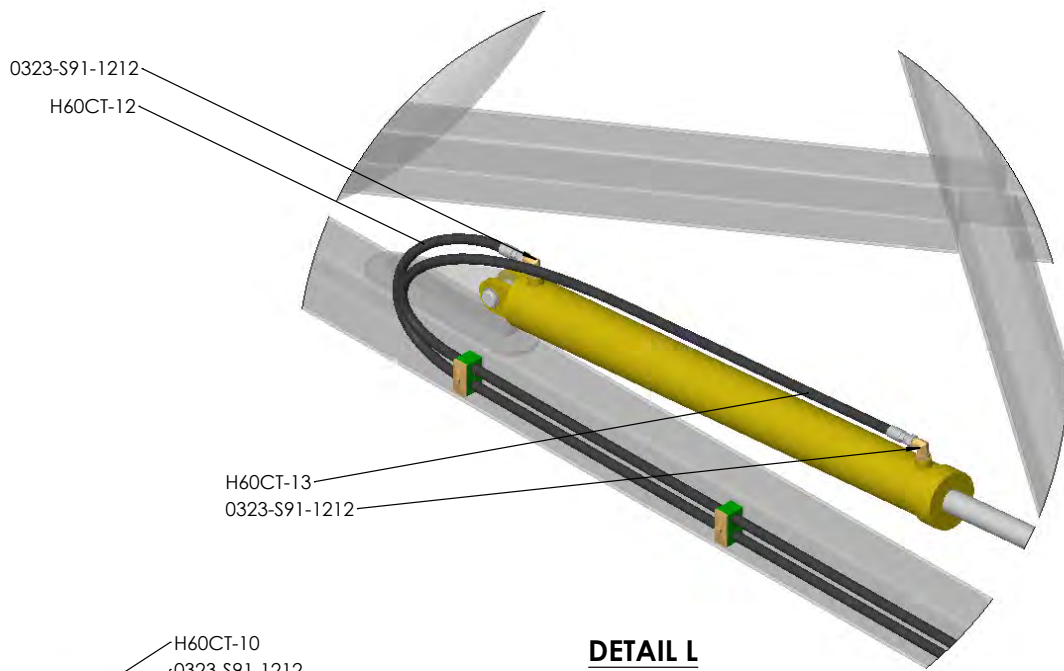

DETAIL L

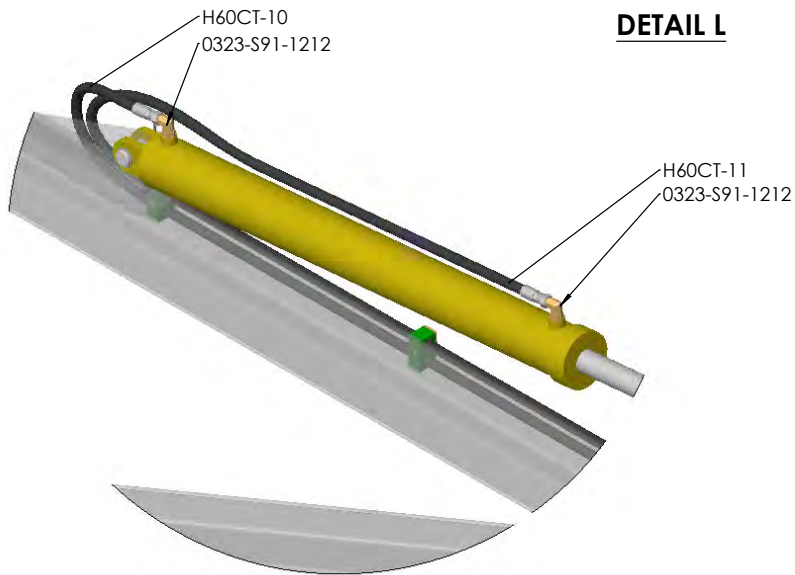

DETAIL M

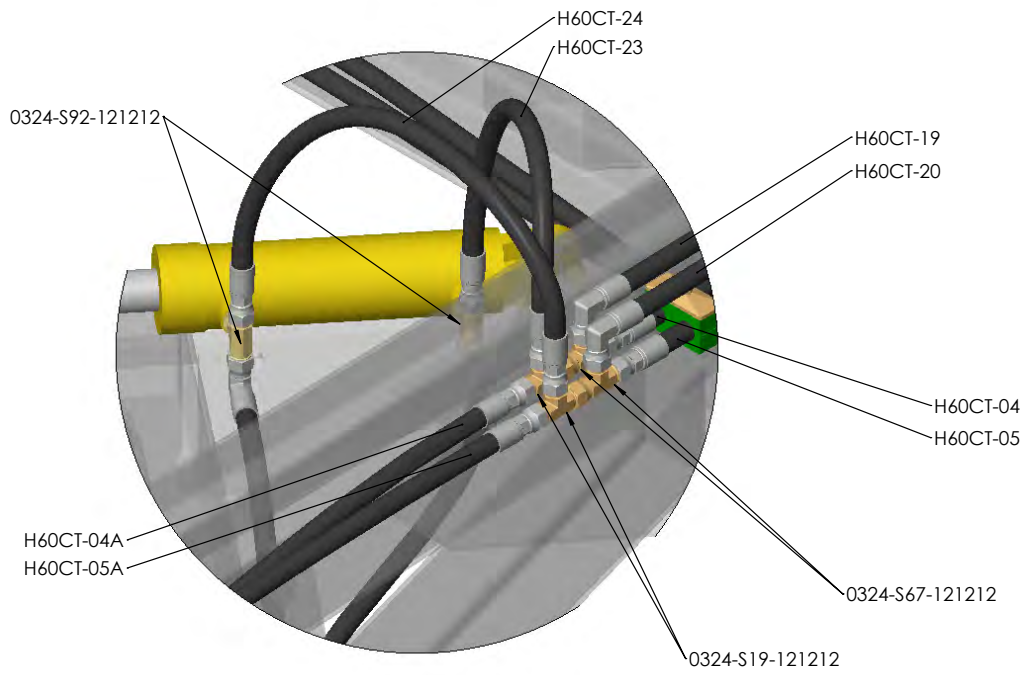

DETAIL N

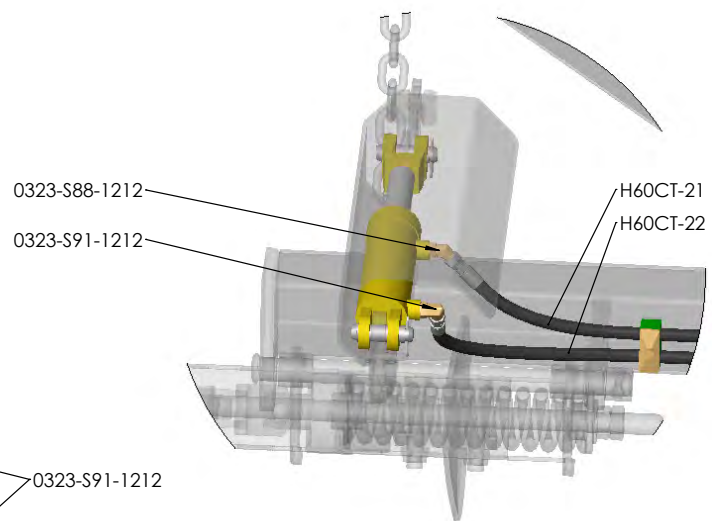

DETAIL O
Reverse View

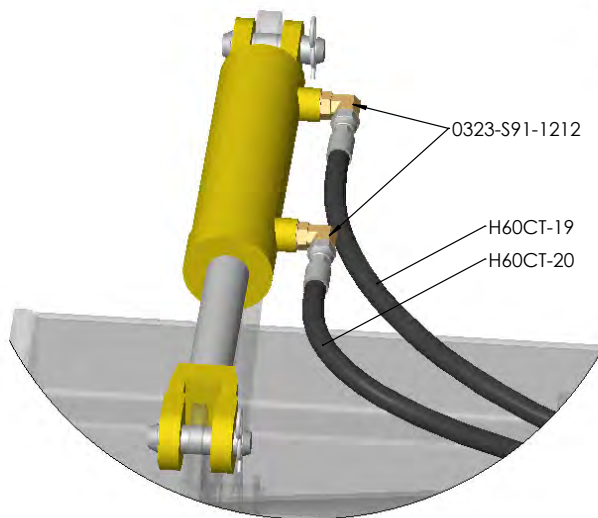

DETAIL P

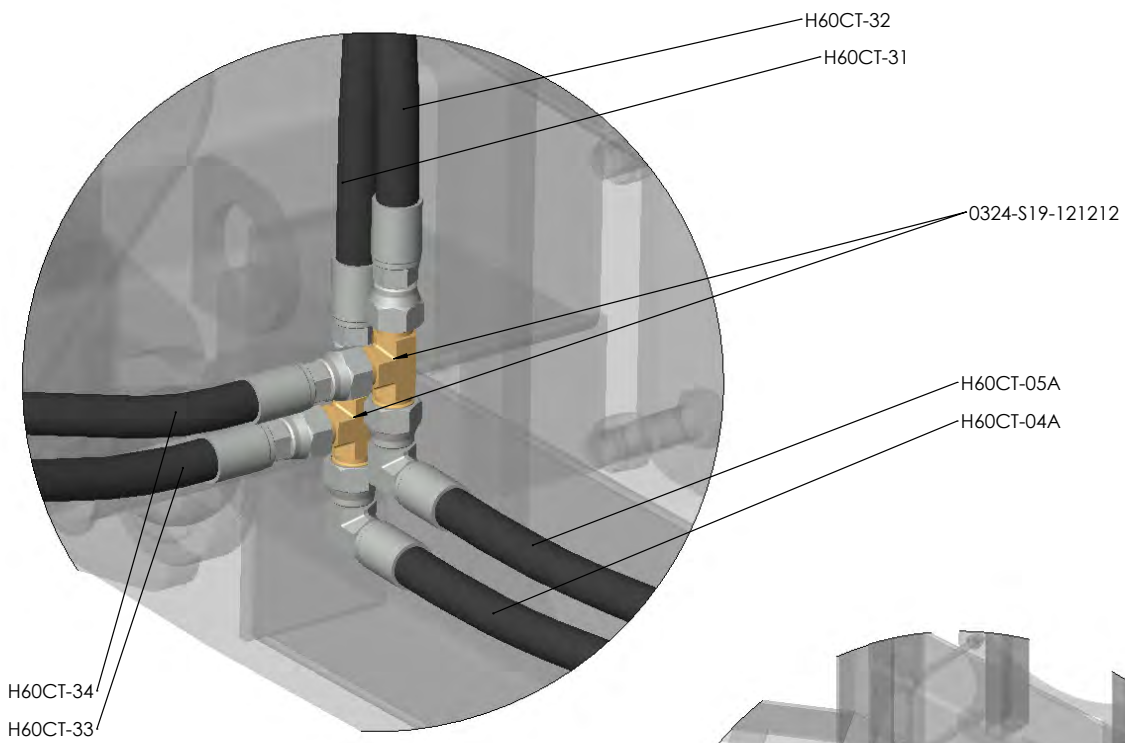

DETAIL Q
Reverse View

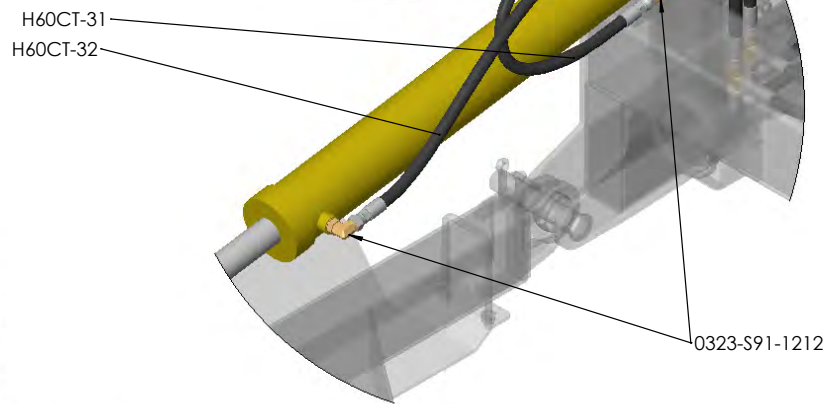

DETAIL R

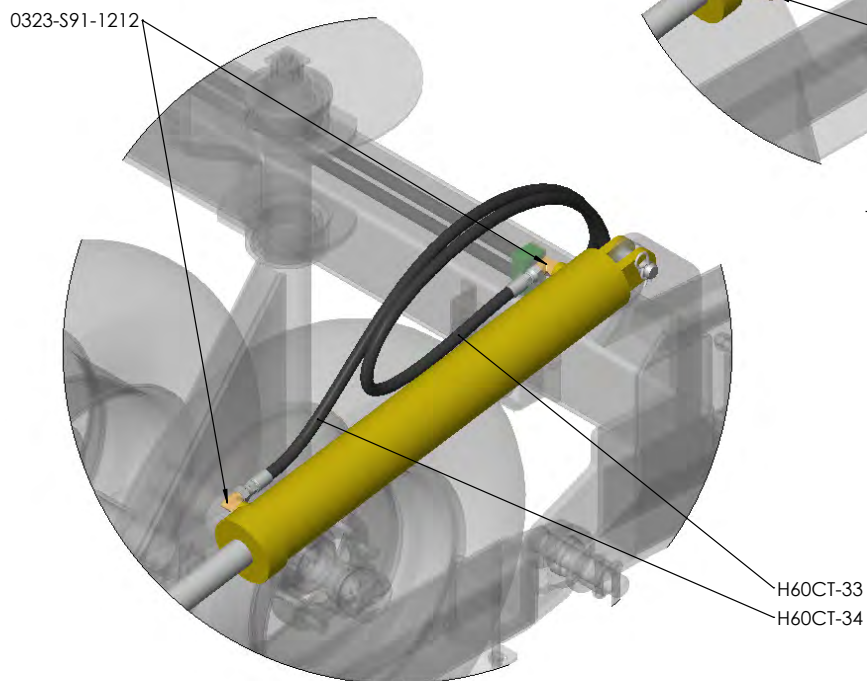

DETAIL S

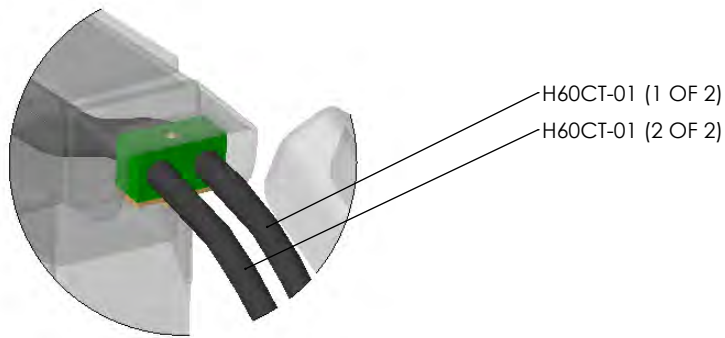

DETAIL T
Reverse View

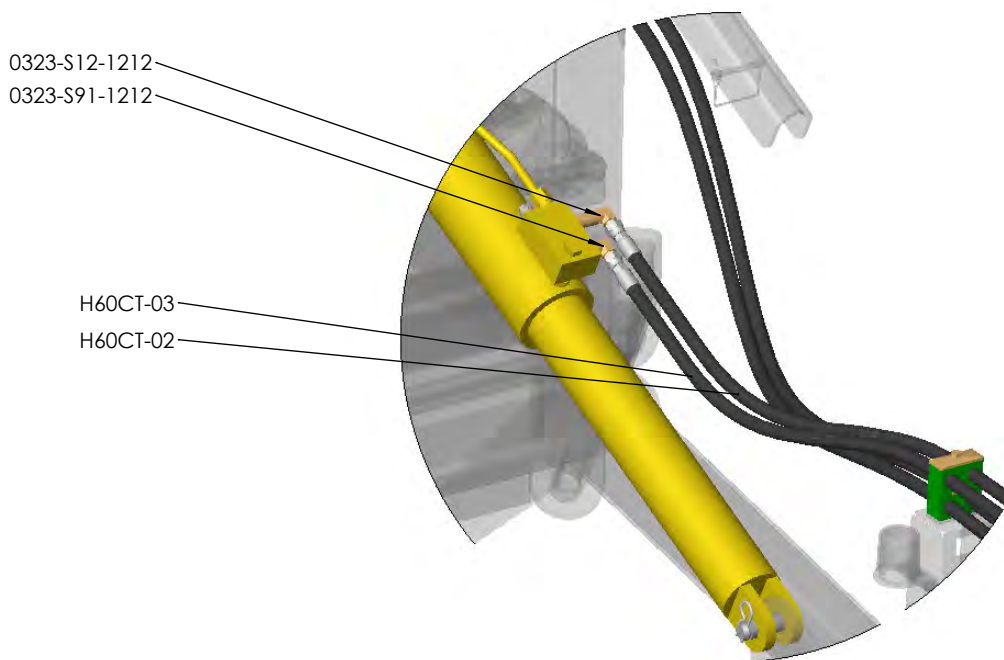

DETAIL U
Reverse View

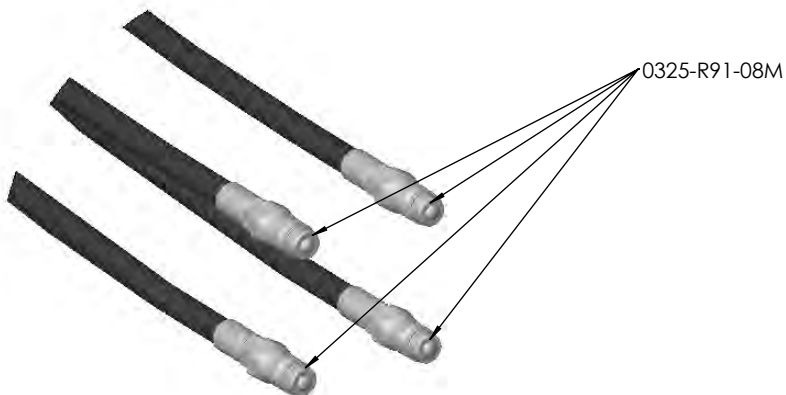

DETAIL V
Reverse View

Section 4

Diagrams and charts

Wiring diagram

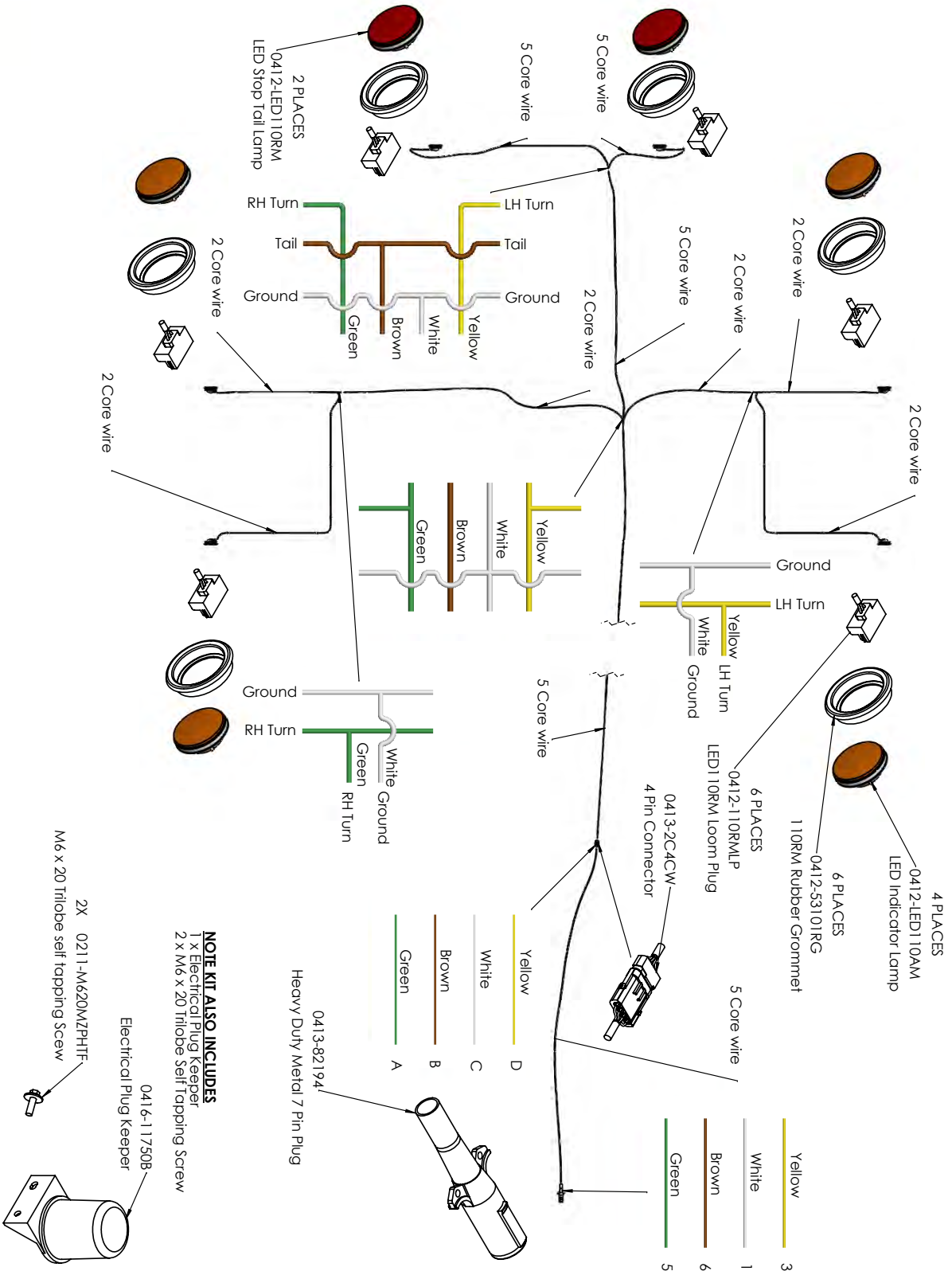

Mounting swivels

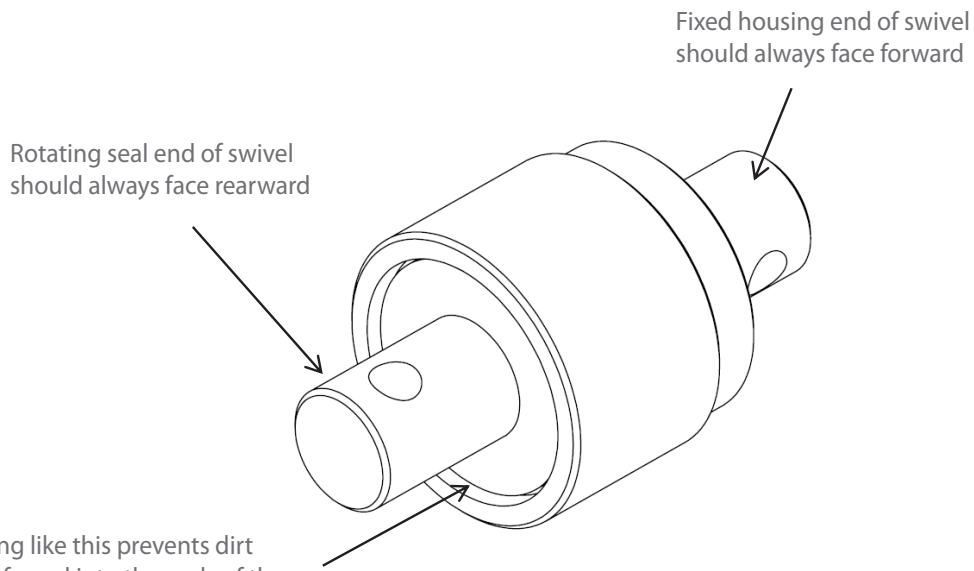

Mounting like this prevents dirt getting forced into the seals of the swivel increasing longevity of the swivel

For example

Swivels attached to the leading ends of the chains should have the rotating seal end attached to the chain, as shown

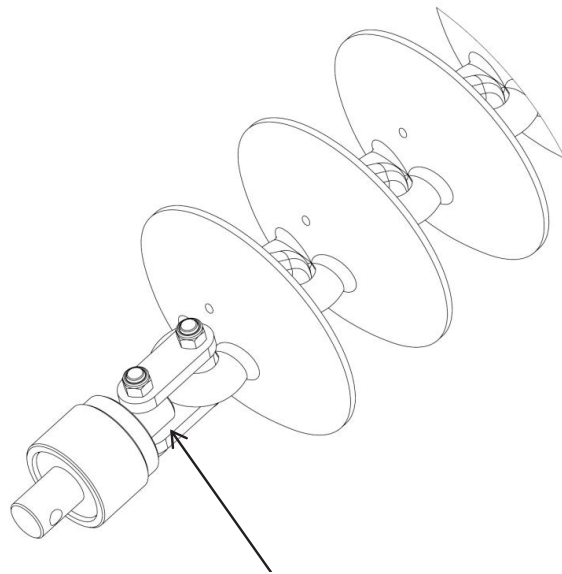
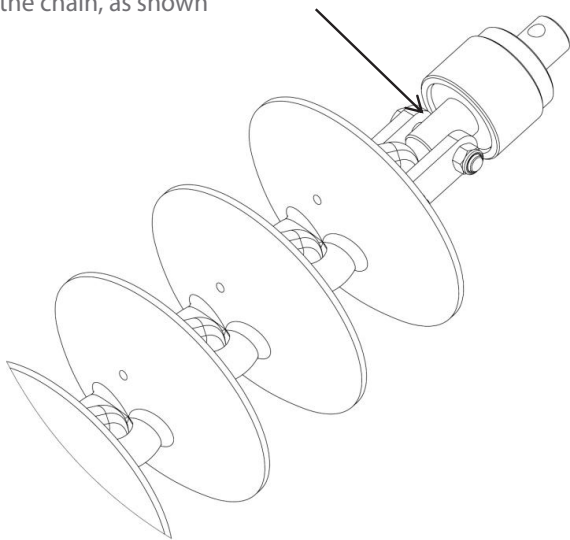

Swivels attached to the trailing ends of the chains should have the fixed housing end attached to the chain, as shown

Fitting cast link retaining pins

Please install cast link retaining Pins (3/8" x 3" Roll Pin, part number 0262-3-8X3) on all cast disc links.

Failure to do this could lead to the discs becoming dislodged during transport causing severe damage or injury.

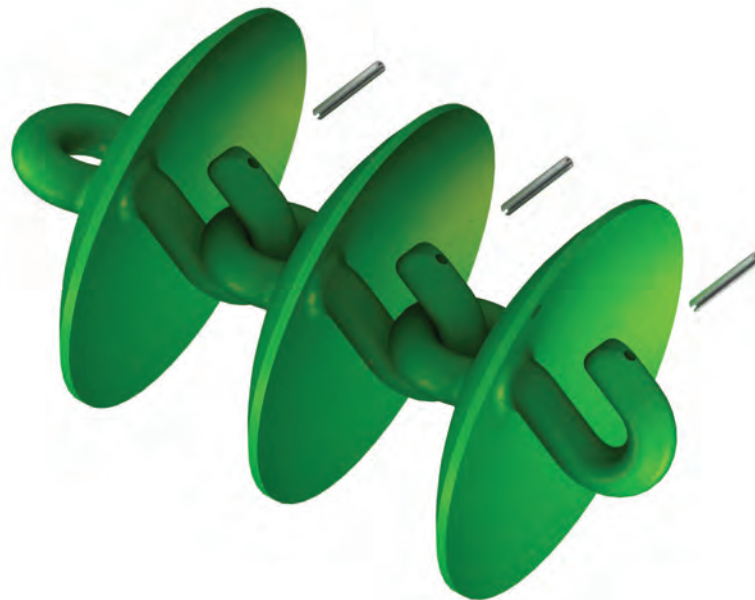
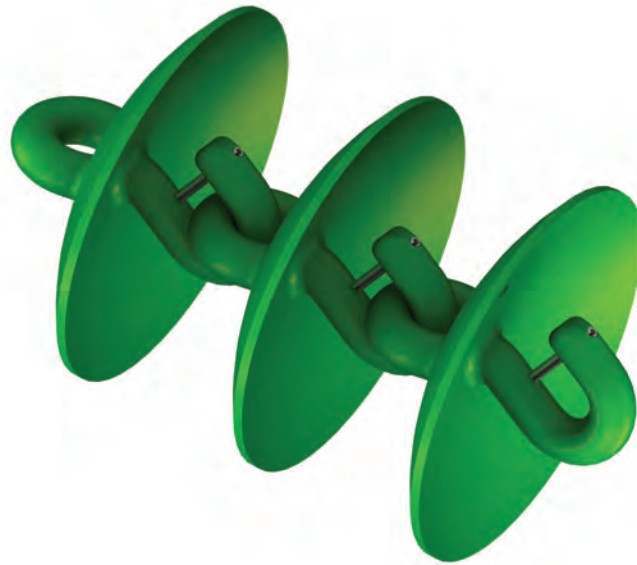

Operating speeds

Operating speeds for normal conditions	
Chain type	Speed
Prickle Chain	6-10 Mph / 10-16 kmph
Disc Mulch Chain	6-8 Mph / 10-12 kmph
Transport / towing on roads	15 Mph / 25 kmph

Tire pressure

Tire size	Ply	PSI	KPA
16.5L x 16.1	14	36	250
H40 x 14.5-19	26	60	410
11L - 15	10	44	300
15.5/80/24	16	58	400
16.5/85/24	16	55	380
550/60/22.5	16	40	280
400/60/22.5	16	50	350
12.5/80/18	14	85	590
15.0/70/18	14	71	490

Chain Harrow specifications

Model	62'/18m	65'
Working width	62'/18.3m	62'/18.3m
Transport width	17'/5.2m	16.3'/5.0m
Transport height	14.6'/4.5m	14.6'/4.5m
Transport length	72'/22.0m	72'/22.0m

Bolt Torque Settings

Bolt Type	Wheel nut				U Bolt			Grade 8.8 Bolt					Grade 10.9 Bolt	
	M18	M20	1/2"	9/16"	M10	M12	M16	M10	M12	M16	M20	M24	M20	M24
Ft lb	255	265	90	100	22	36	55	32	48	140	190	270	300	350
Nm	345	360	125	140	30	50	75	44	65	190	260	370	406	475

[1] When fitting a wheel & tire to a hub, do the wheel nuts up in rotation to the correct tension. To achieve this choose a wheel nut & tighten, then go clockwise to the next wheel nut & tighten & so on until all wheel nuts are tight. Then repeat the procedure to check that all nuts are tight. Do not use impact tools to tighten wheel nuts. For a guide to the correct tension of the wheel nuts please use the appropriate tension for your size wheel nuts from the Bolt Torque Settings table.

Torque values are for dry threads and surfaces however it is permissible to apply a small amount of anti corrosive oil to the threads.

Disc Chain lengths

Model 60CT/62		Length	CL2	CL1	W36	R300	SD49	Prickle chain
			CL2 disc chain also requires CL1 disc chain					
60CT / 62	Front right	38.7'/11.8m	CL2 - 53 CL1 - 2	71	70	93	93	129
	Front left	38.7'/11.8m	CL2 - 53 CL1 - 2	71	70	93	93	129
	Rear right	44.3'/13.5m	CL2 - 53 CL1 - 11	81	80	105	105	146
	Rear left	38.7'/11.8m	CL2 - 53 CL1 - 2	71	70	93	93	129
	Modules front	10.3'/3.15m	CL2 - 13 CL1 - 2	19	19	25	25	35
	Modules rear	10.3'/3.15m	CL2 - 11 CL1 - 2	17	17	22	22	31

Section 5

Operation

Basic Operation

Unfolding:

1. Walk around and inspect the machine.
 - a. Check that chains are not hooked on framework
 - b. Check swivel bolts are in place and not broken
 - c. Check that height adjusting chains have not fallen out of their slotted plates during transport.
2. Lower front A frame to working height.
3. Unfold wings holding the hydraulic lever until the tail is in working position and the main center cylinder pins have centered in their slots.
4. Walk around and check that all chain links are straight and that working height of all swivels is correct for field conditions. Adjust if necessary.
5. Move off with all chains in working position. If necessary it is acceptable to raise front A pull to transport height. This will lift the front chains off the ground and reduce the load on the tractor. Lower the front A pull once moving satisfactorily.

Folding:

1. Lower the front A frame to working height. (This is important to ensure that all chains locate correctly in their transport rests).
2. Fold the wings. They should move as follows; modules will raise, tail will raise, main center cylinders will retract, one or both, until the wings stand vertically. The left outer wing then the right outer wing will fold down.
3. Raise front A frame to transport height.
4. Walk around and check that chains have located correctly in transport rests.
(30' only, install wing transport lock pins).

Setting for correct chain tension

Wings

Use the spanner supplied. Loosen the lock nut adjacent to the tensioner assembly body. Turn the tension bolt clockwise to compress the coil spring. Correct tension is achieved when spring retains its set length when operator rolls the chain fore and aft on the ground. Retighten the lock nut. See table below

Spring Compression Length

Model	inches	mm
60	12.4	315

When less than 4" (100mm) of thread remains visible on the adjustor bolt then a link must be removed from the chain



Modules

Loosen the lock nut on the draw bolt.

Tighten the adjusting nut clockwise until the outer face of the spring retaining washer is flush with the body of the module tensioning unit.

Retighten the lock nut.

If more than 8" (200mm) of thread is exposed then a link should be removed to maintain correct adjustment.



Importance of chain tension

Operational

It is imperative that the correct adjustment be maintained. Only through correct adjustment can a smooth and level finish be achieved in field working.

Loose chains lead to :

- Uneven performance across the width of the machine
- Uneven weed control
- Unsatisfactory incorporation
- Ineffective levelling
- Accelerated or premature chain wear
- Chains failing to engage with transport locators when folded
- Machine damage when folding or unfolding
- Uneven field surface with ridges and furrows being created. The leading 1/3rd of a loose chain is much more aggressive than the trailing 1/3rd and the center. This will mean that middle of the machine's front pair of chains will aggressively move soil outwards. The machine's rear pair of chains, if loose, have their aggressive 1/3rd near the wing extremity. It follows then that as the front discs push soil outwards, the least aggressive portion of the rear chain follows them and does not balance the soil movement. This is exacerbated at the wings, effectively creating a broad ridge about halfway out each wing. It won't be evident in one pass, but is possible if care is not taken over time.

A correctly adjusted machine will not cause this phenomenon.

Settings for correct working height

To adjust the swivel height at the wings, relocate one of the polyurethane spacers either above or below the fixed mounting tube.

Adjustment

1	Loosen chain tension completely
2	Undo self tapping screw from corresponding spacer then prise open the spacer and spring it off of the drop leg tube
3	Replace it in the selected position after raising or lowering the drop leg
4	Reinstall the self tapping screw and re-tension the chain

It is possible to install all spacers either above or below the mounting tube giving a maximum of 4" (100mm) of adjustment.



Front Cylinder Depth Stop

ITEM NO.	PART NUMBER	Revision	DESCRIPTION	QTY.
1	0211-12110SHSCREW	A	Shoulder Screw M12 x 16 x 110	2
2	0231-SPRINGCUP	A	Compression Cup Washer	7
3	0800-278	A	Cylinder Depth Stop Plate	10

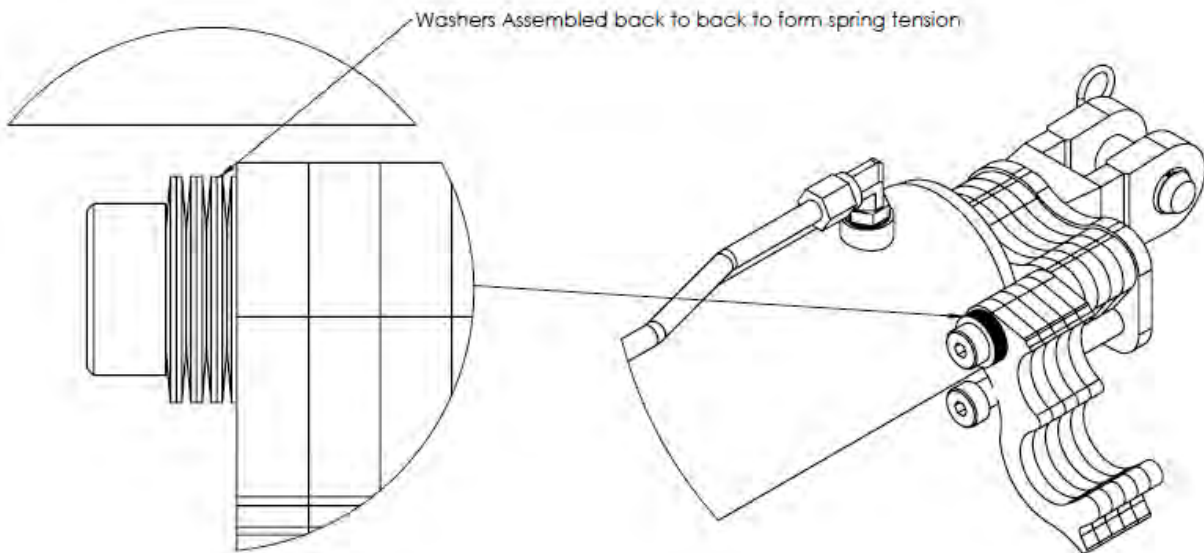
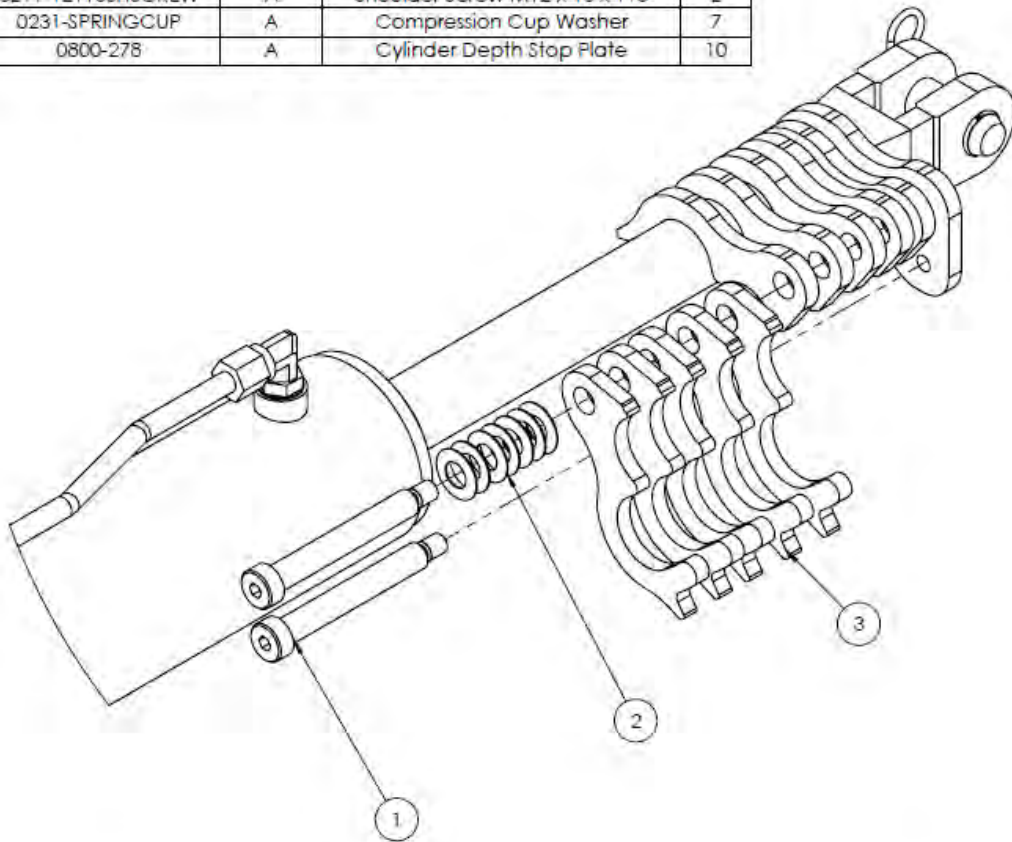

Hydraulic Valve Block

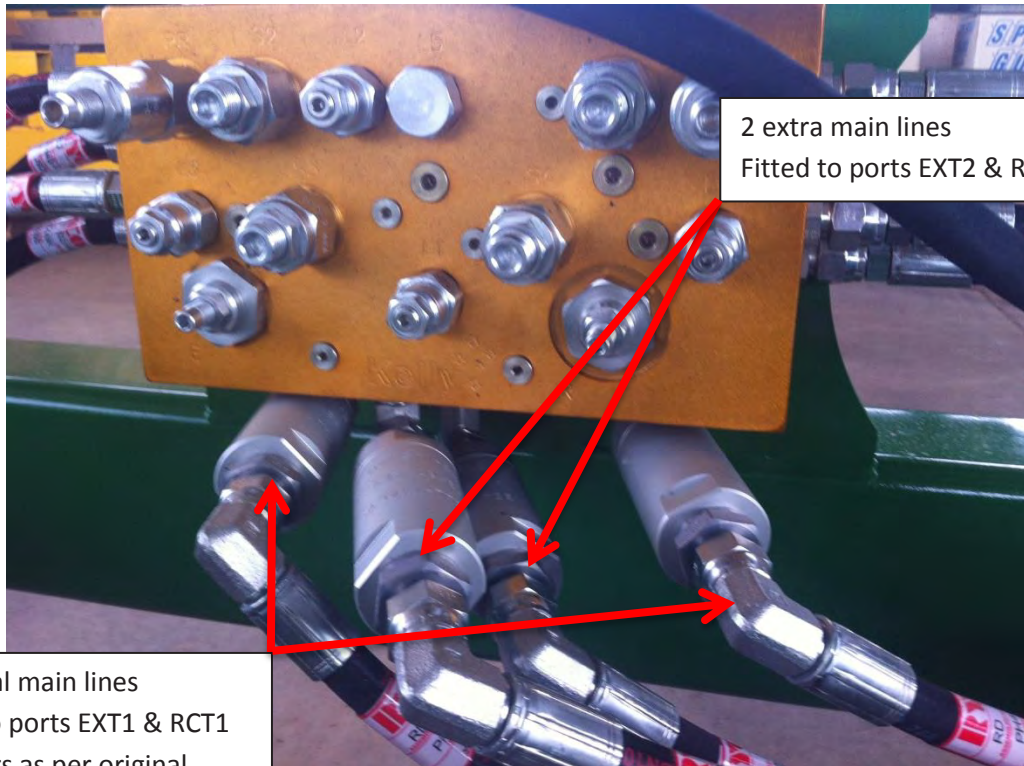

2 extra main lines
Fitted to ports EXT2 & RCT2

2 original main lines
Fitted to ports EXT1 & RCT1
Via filters as per original
OUT end of filter to valve
block



Extra stack clamp added to
mount extra main lines to
existing main lines

New hose mount post with
extra storage points

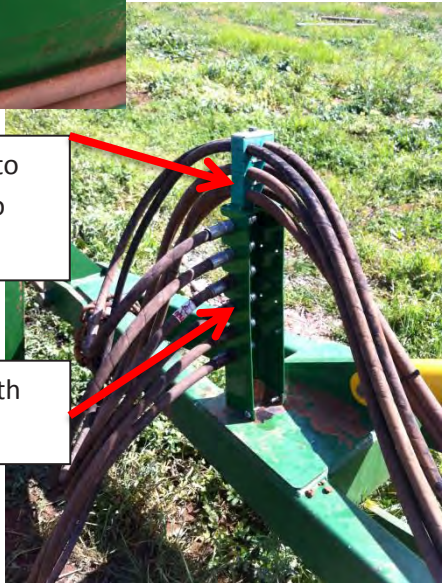

Rear Light Brackets

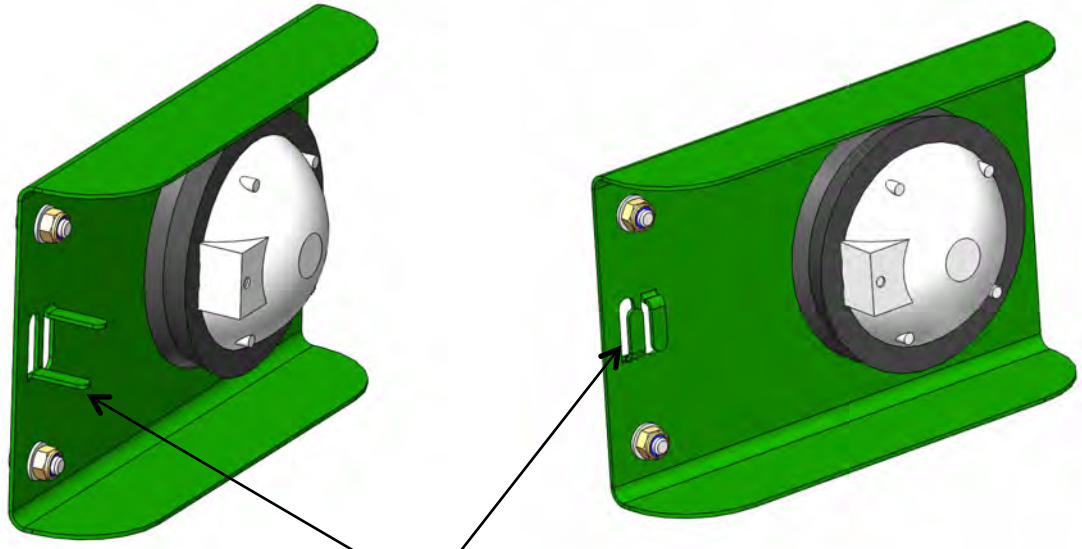

Please ensure to bend tabs up and feed wire through, so the light cable is secure

Mount to chain carrier with 2x M8x20 cup head bolts, Flat washer and Nylon nut

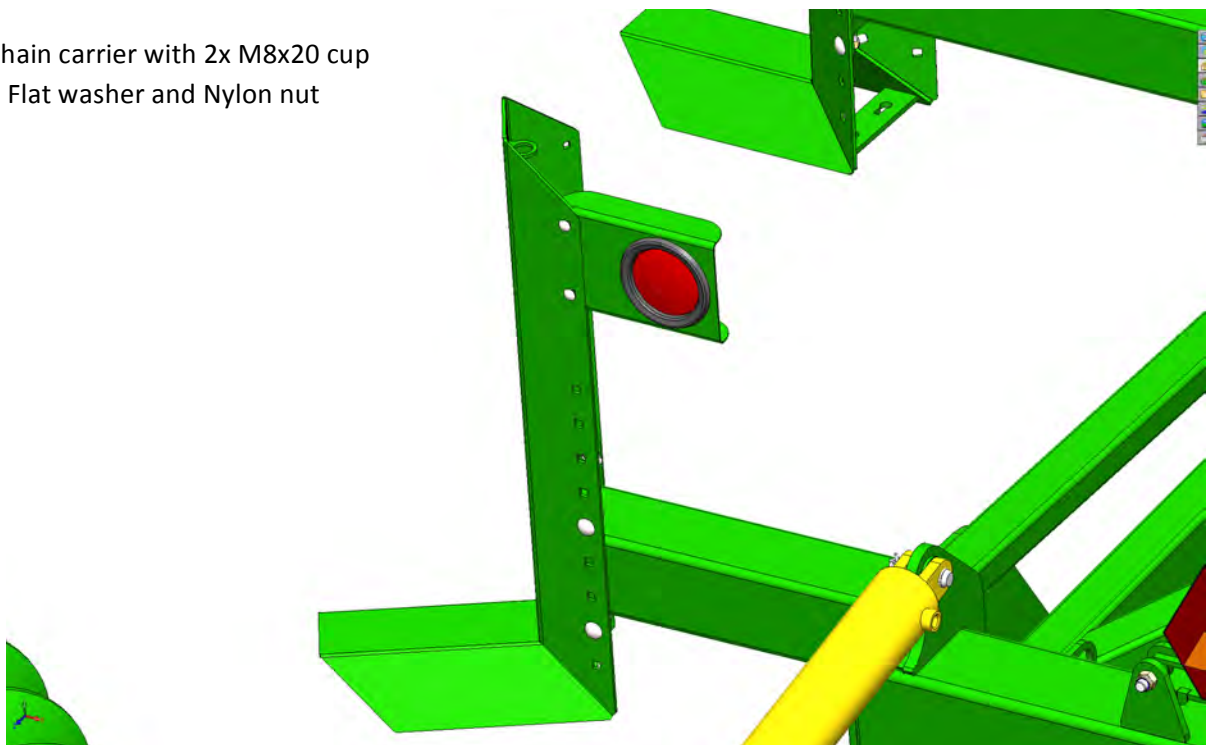

Brake Disc Collar (Revision B)

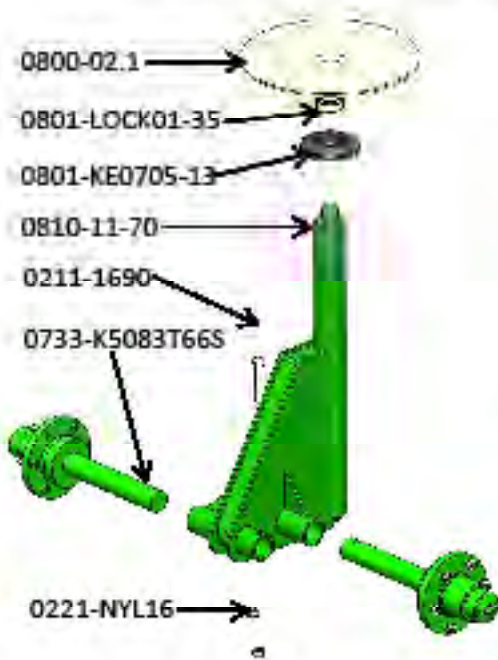

Slide shaft of jockey wheel up through both bearings.

Place black dust cover onto top bearing.

Slide disc brake into the calliper and over the top of jockey wheel.

Ensure when unscrewing bolts to fit collar over that some thread is still engaged otherwise you will not be able to screw bolt in.

Slide collar over shaft and inside the brake disc hole.

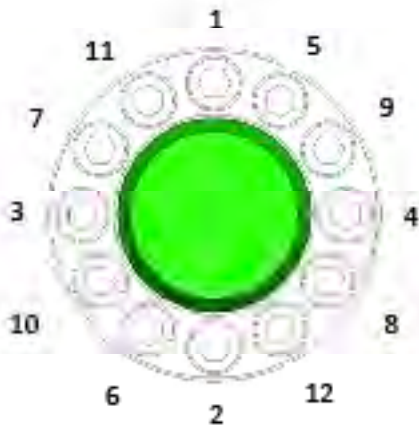
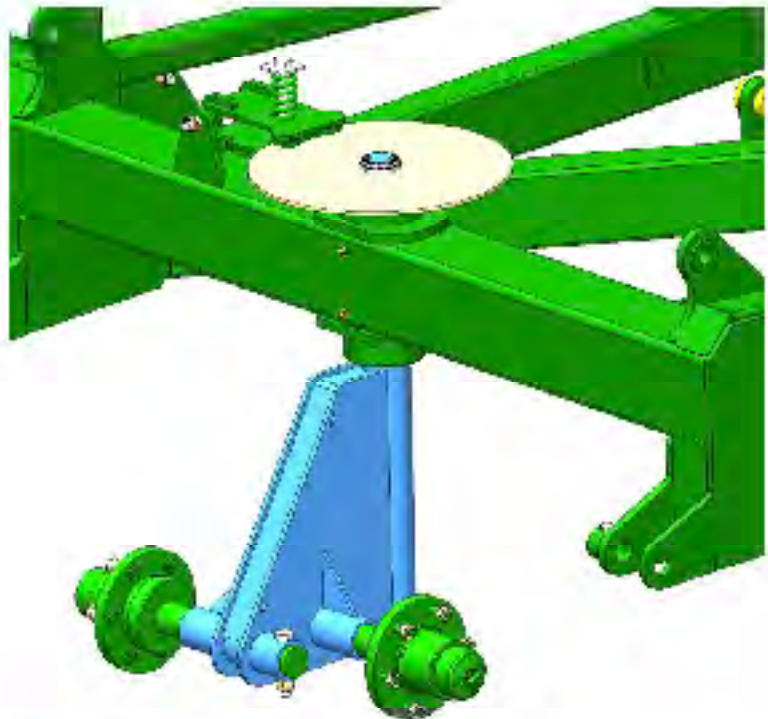

Tighten in a cross pattern, Bring all bolts up equally to 17Nm (12.54 Ft/Lbs) (caution if a single bolt is done up to tension there is a risk of the bolt breaking)

To undo, remove all bolts and gently tap collar with a hammer and collar should become loose.

Correct Hose Attachment

Please note that when attaching hoses to sequence valve block to check that hoses are connected to the correct port.

Ports with CE, LE or RE are extend ports (the E denotes Extend) and hoses connected to these must go to the rear end of the cylinder.

Ports with CR, LR or RR are retract ports (the R denotes Retract) and hoses connected to these must go to the rod end of the cylinder.

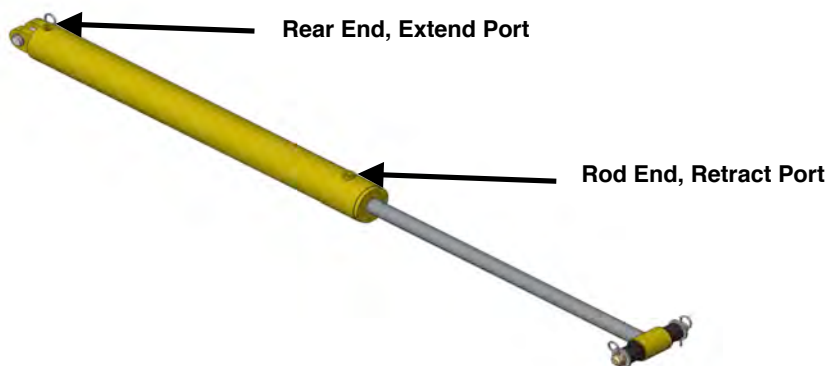

CL2 Chain Configuration - All Machines

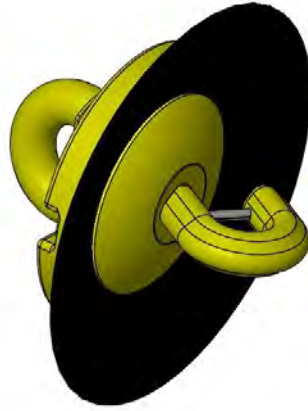

0803-CL2-Link Assembly

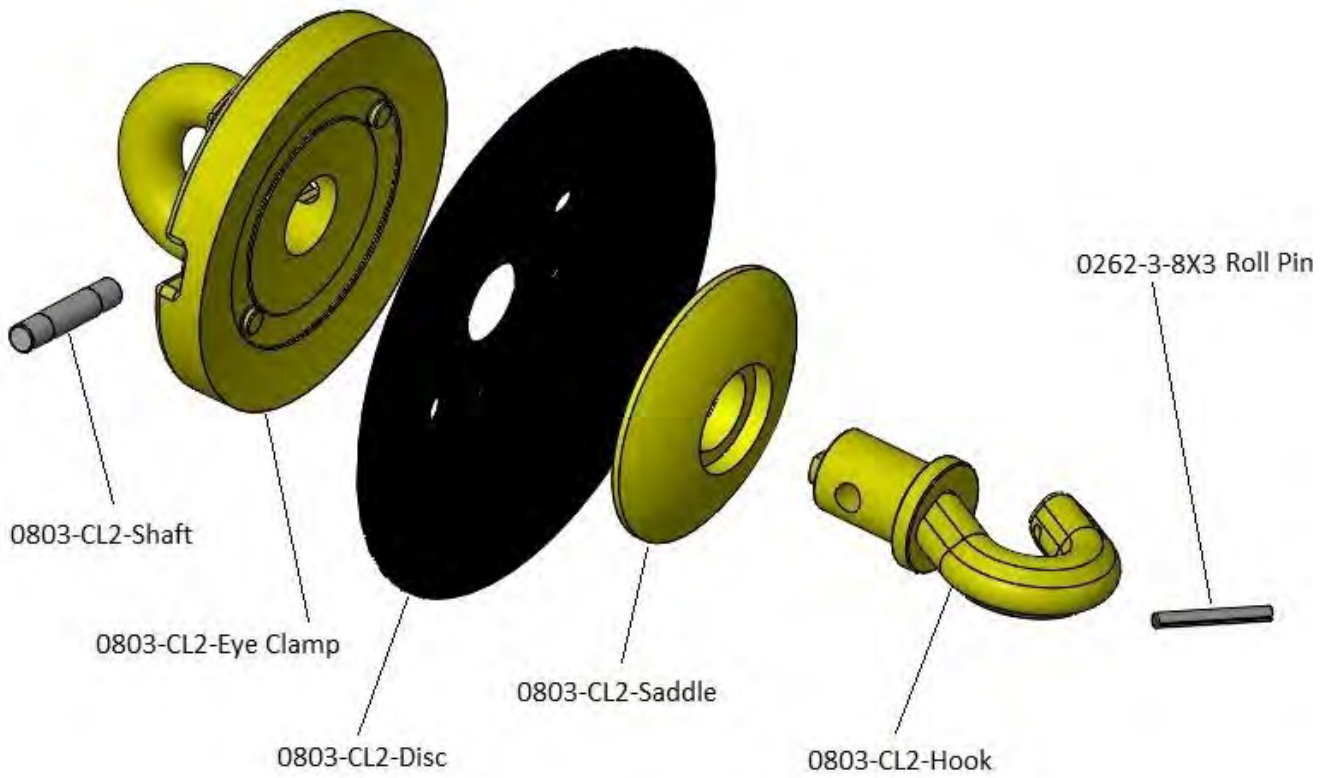

CL2 Chain Configuration - 60ft

60' Machine

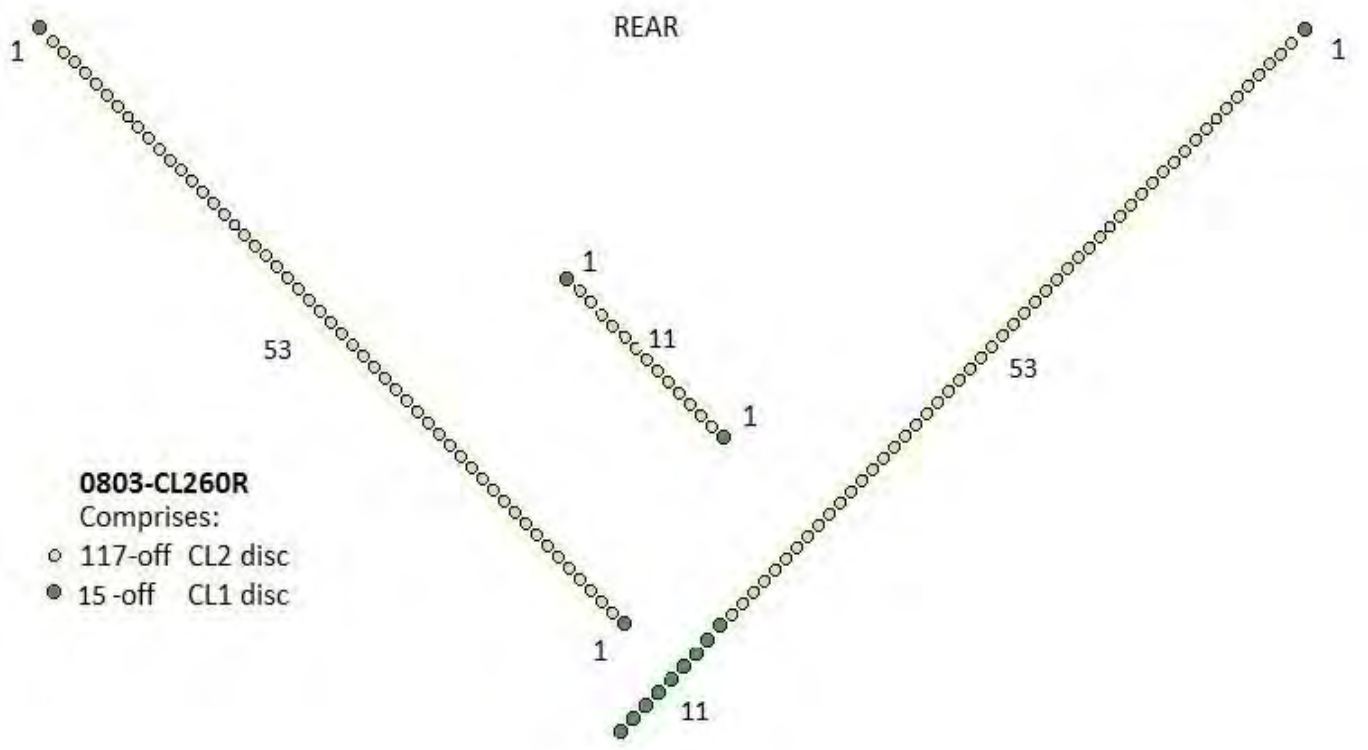
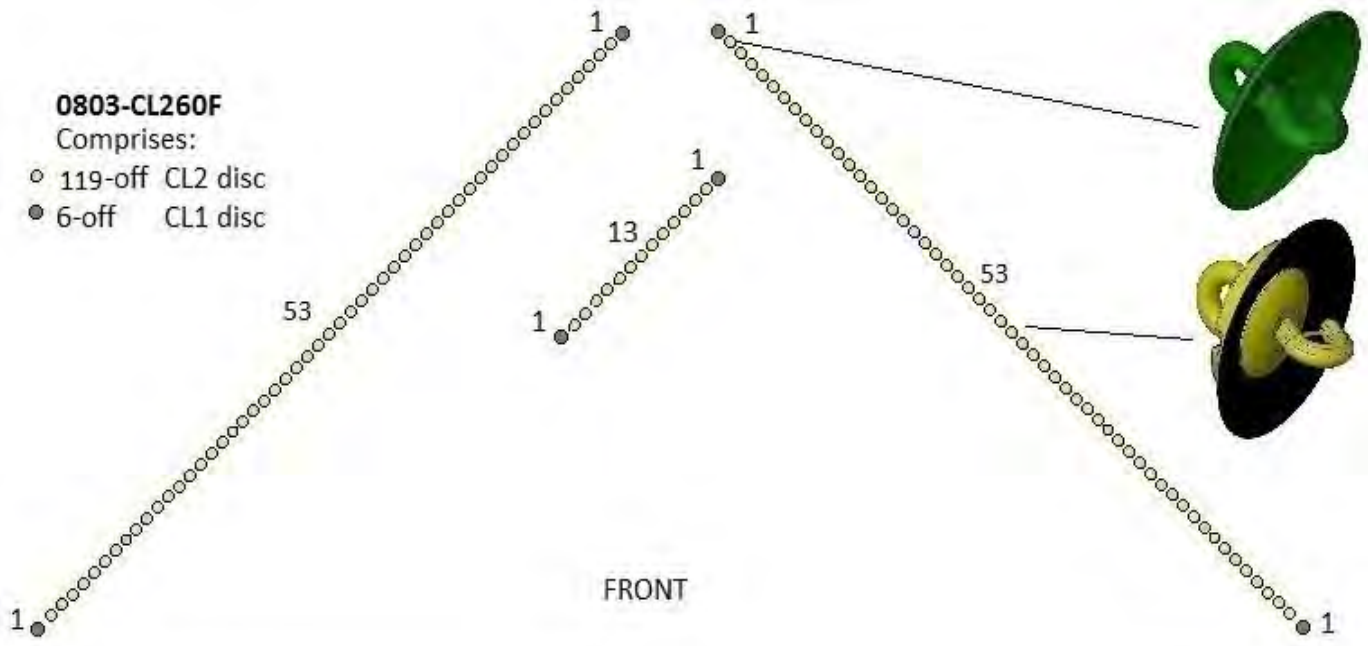

CL2 Disc Change Procedure

This document describes a procedure for the safe changeover of CL2 discs.

NOTE: Each disc weighs 22kg (48lb). Appropriate care must be taken during manual handling

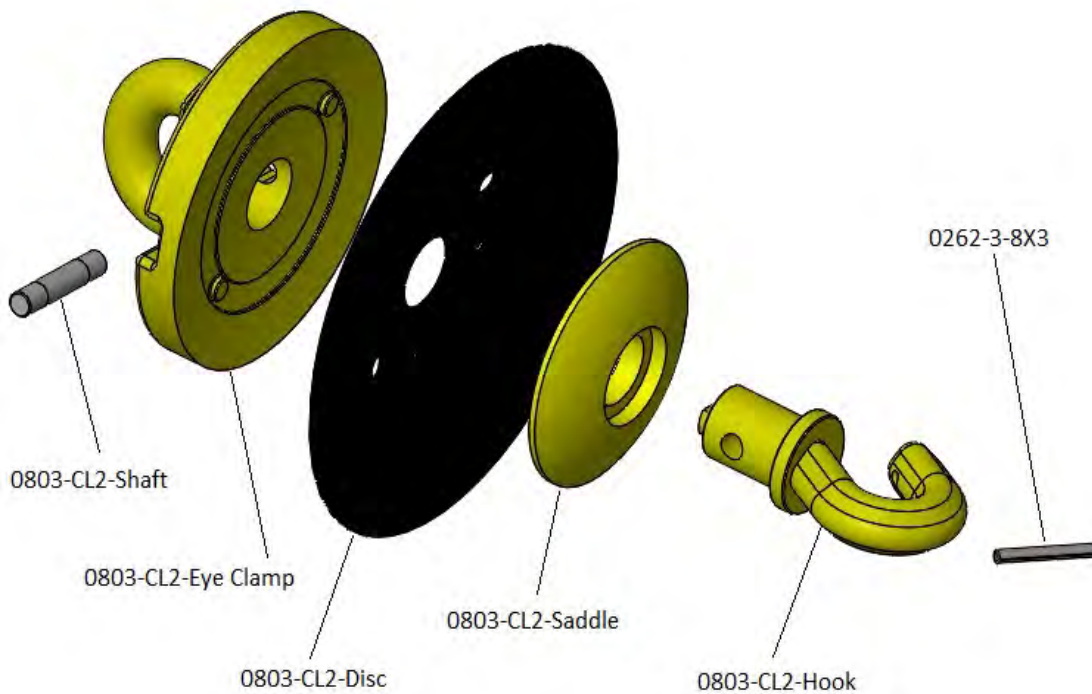

Figure 1: Exploded view of CL2 disc assembly

Changeover procedure as follows:

1. Locate press jig in press (see Figure 2 for orientation).
2. Load disc into press with Hook facing upwards - ensure that Eye Clamp and Hook are secured within the jig with pins supplied
3. Close press, applying force to Saddle (see Figure 3). DO NOT exceed pressure of 9 Tonne (19,800lb)
4. With the clamping force applied, push or tap the shaft with a hammer & drift, and remove from the CL2 Disc assembly
5. Open the press and remove the Disc from the assembly
6. Ensure that all surfaces of the castings are free from debris

CL2 Disc Change Procedure

7. Place replacement disc on to Eye Clamp, ensuring that location holes align with casting lugs
8. Close press and re-apply clamping force. Visually confirm that Hook location hole is properly aligned with Eye Clamp location hole
9. Locate pin within hole and tap gently through both castings
10. Remove clamping force, and remove CL2 assembly from jig
11. CL2 disc is now ready for use. Repeat procedure as necessary

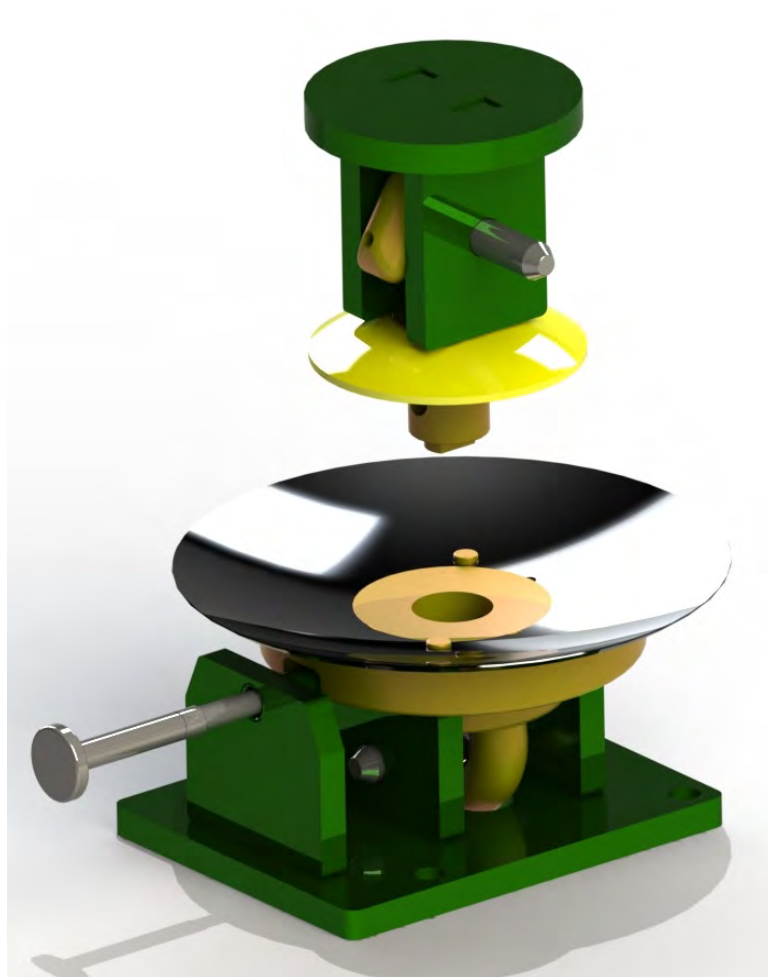

Figure 2: CL2 disc with press jig in Open position

CL2 disc change Procedure



Figure 3: CL2 disc with press jig in Closed position

