



Kelly



**KELLY TILLAGE SYSTEM
HYDRAULIC SEQUENCE VALVES**

Revision D February 2022

Kelly Tillage
PO Box 100
Boileroo Centre SA 5482
Australia

Phone: + 61 8 8667 2253
Email: sales@kellytillage.com
Website: www.kellytillage.com



Thank you for choosing a Kelly Tillage product

We trust that you find the following manual clear and easy to follow. If you should require additional customer support or assistance, please do not hesitate to contact us.

Spare parts can be purchased, as required, through your local dealer or by contacting Kelly Tillage or in the United States, Hood & Company.

Kelly Tillage welcomes feedback. Should you have any difficulties that you wish to raise, suggestions for improvement or modifications that you feel would enhance our products we look forward to hearing from you.

Kelly Tillage

PO Box 100

Booleroo Centre SA 5482

Phone: + 61 8 8667 2253

Email: sales@kellytillage.com

Spare Parts: parts@kellytillage.com

Website: www.kellytillage.com

Spare Parts (USA)

Hood & Company Inc

Springfield MO

Phone: + 1 417 865 2100

Email: parts@hoodco.com

Spare Parts (Canada)

Adair Sales & Marketing Company

Swift Current SK

Phone: + 1 306 773 0996

Email: info@adairreps.com



KELLY TILLAGE SYSTEM

HYDRAULIC SEQUENCE MANIFOLDS

This manual contains information relating to the operation and spare parts of each of the hydraulic sequence manifolds used on the Kelly Tillage System, beginning with the most recent manifold 692196 (version 12.5) and working back over the years.

Contents

Sequence Valve Overview	3
Sequence Valve Manifold – Flow Chart	4
Explanation of Valve Function.....	5
General Troubleshooting: All Manifolds	6
Sequence Manifold Identifier for all double fold models.....	7
292196, V12.5 - split circuit.....	9
HF111938-16, v12 split circuit.....	13
Technical Bulletin 91a: V12 Manifold Filter Seal.....	17
290509, v10 - split circuit	21
290430, v9 - split circuit	22
290380, v8 - split circuit	23
290179, v7 - split circuit	24
228712, v6	26
227654 / 287654	27
Model 30	28
Trouble Shooting.....	30
Unfolding.....	30
Folding	34
Working.....	37
Appendix A: Troubleshooting Guide for V12 Manifold	38
Contact Details.....	40
Notes.....	41



Sequence Valve Overview

The sequencing valve manifold incorporated in Kelly Tillage System provides simple and reliable operation. The manifold is pressure sensitive - once set right, it will give many years of trouble-free service. If operating conditions change it may be necessary to make adjustments to various valves. These factory settings are specific to your manifold and are listed under the appropriate chapter, should you need to start again.

The valve manifold controls the folding and unfolding of the Kelly Tillage System. One or two pairs of hoses connect the valve manifold to the tractor. One pair operates the tail and module circuit. The other pair fold and unfold the wings. Only newer models have the second pair for the tail. A third pair of hoses operate the Front A-Frame cylinder.

Oil is directed to the first stage of a fold or unfold sequence. When the cylinders reach the end of their stroke and pressure mounts, a sequence valve is triggered allowing oil to flow to the next stage. The sequence valves automatically reset themselves when system pressure allows.

The valve manifold incorporates over-center or counterbalance valves as a safety measure. These O/C valves prevent the tail or wings from falling in the event that one of the tractor hoses should fail, manage smooth folding and hold the wings straight out in their working position. The newest type manifolds incorporate pressure control valves to prevent damage to the machine in case things go wrong when folding.

For the purposes of this instruction, view all directions as though standing behind the machine looking forward.

The early version of the valve manifold had a maximum flow capacity of 8 Gallons (US) per minute (30Lpm).

Dual Function

Manifolds from version 8 forward have the ability to allow independent raising and lowering of the tail section. This means that when crossing roadways or waterways the front and rear can be quickly raised partially to lift the chains clear of the ground. This allows you to back into corners of fields and improves turning on end rows. Raising the tail partially also removes the divot made by the tail from turning too tight. The new functionality requires 3 pairs of tractor remotes to operate. It will be possible to operate the machine successfully on a tractor with only two circuits after some minor alterations to hose connections and routing.



Sequence Valve Manifold – Flow Chart

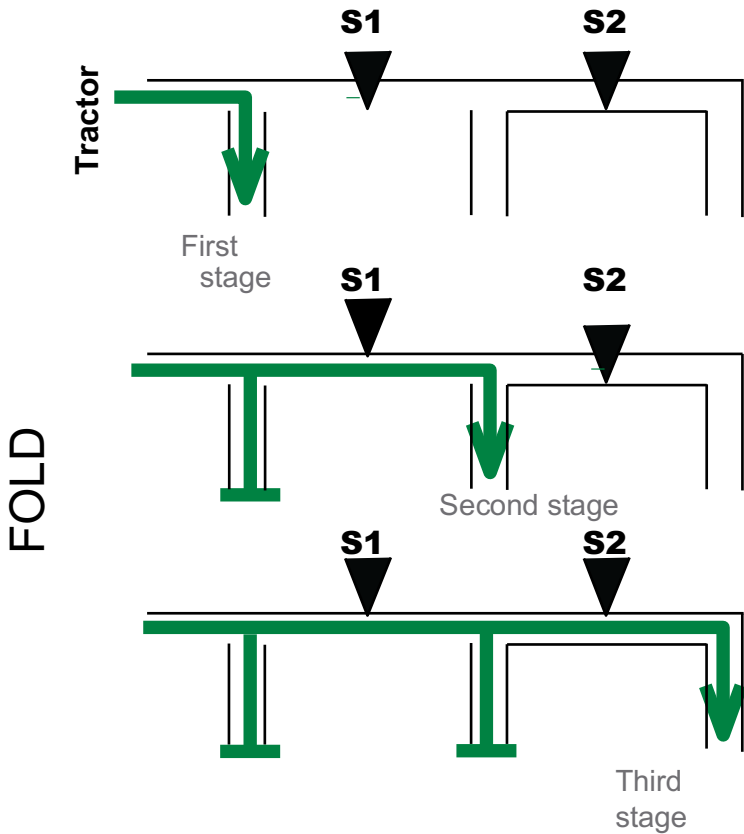

Step 1 -Raise Tail and Modules fully.

Step 2 -Raise wings until folded

Stage 1

S1 closed S2 closed
Oil is flowing to main wing cylinders

Stage 2

S1 open, S2 closed.
Oil is flowing to left outer wing

Stage 3

S1 & S2 open.
Oil is flowing to right outer wing

Step 3 -Raise front A-Frame fully

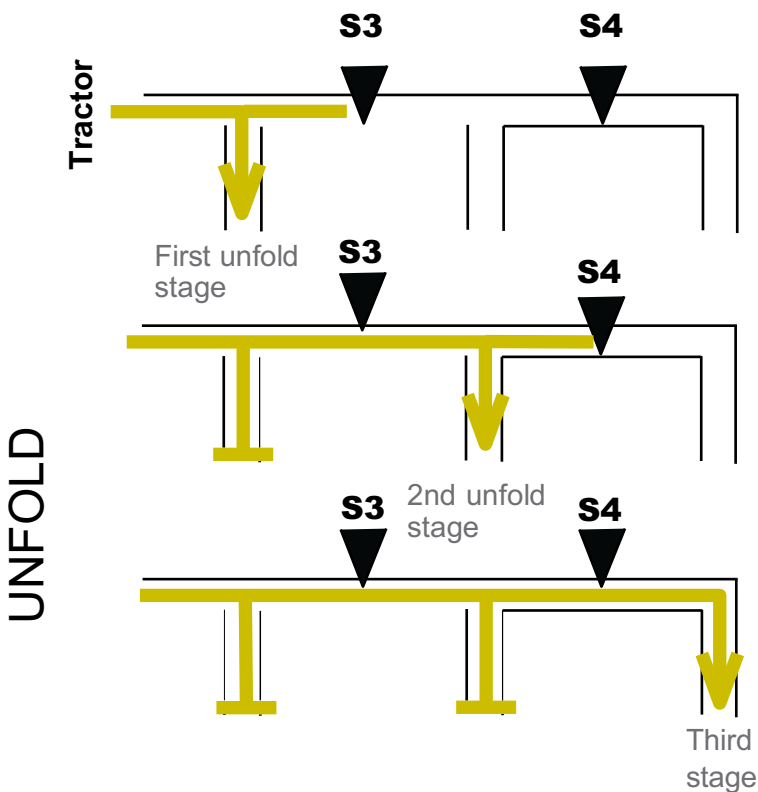

Step 1 - Lower front A-frame to working position.

Step 2 - Unfold wings fully

Stage 1

S3 closed.
Oil is flowing to right outer wing

Stage 2

S3 open, S4 closed.
Oil is flowing to left outer wing

Stage 3

S3 open, S4 open.
Oil is flowing to main wings

Step 3 - Lower Tail and Modules fully.



Explanation of hydraulic flow

Unfolding

When the machine is **folded** and trying to **unfold**, the fluid enters the **bottom** of the block, travels through the **filter** on the side of the block then through the **E** flow control valve. The fluid then travels to the **first** stage of the **unfold** circuit which is to stand up the right-hand outer wing. After right hand wing is vertical, **S3** should open and allow oil to the left-hand outer wing. With both wings vertical **S4** should open and allow the wings to unfold to ground level.

Folding

When the machine is **unfolded** trying to **fold**, the fluid enters the **bottom** of the block, travels through the **filter** on the side of the block then through the **R** flow control valve. The fluid then travels to the **first** stage of the **fold** circuit which is to raise the two main wings straight up. Once the two wings are vertical **S1** valve should open to allow the left-hand outer wing to fold. **S2** valve will then open to allow the right-hand outer wing to complete the folding sequence.

Explanation of Valve Function

Main wing fold circuit

- E Flow controller to increase or decrease oil flow for extending (unfolding) wing fold cylinders.
- R Flow controller to increase or decrease oil flow for retracting (folding) wing fold cylinders.
- PR Pressure reducing valve to protect right wings when folding.
- PL Pressure reducing valve to protect left wings when folding.
- S1 Sequence valve that remains closed until main cylinders are closed (inner wings fold vertical) It then opens to allow left outer wing to fold.
- S2 Sequence valve that remains closed until left outer wing is folded. Then opens to allow right outer wing to fold.
- S3 Sequence valve that remains closed until right outer wing unfolds to vertical. It then opens to allow left outer wing to unfold.
- S4 Sequence valve that remains closed until left outer wing unfolds to vertical. It then opens to allow main wing cylinders to extend and unfold both main wings to working position.
- L1 Over Center valve that holds main wings in position if tractor hose fails. Prevents wings falling.
- L3 Over Center valve that holds the right wings out straight when working.
- L4 Over Center valve that holds the left wings out straight when working.
- C1 Check valve for return oil from right outer wing unfold. Can seem like S2 problem.
- C2 Check valve for return oil from left outer wing fold. Can seem like S3 problem.
- C3 Check valve for return oil from left outer wing unfold. Can seem like S1 problem.
- C4 C5 Check valve for return oil from main wing cylinder folding. Can seem like S4 problem.

Tail & Module circuit

- L2 Over Center valve that holds tail in raised or partially raised position.
- L5 Over Center valve that holds the two centre module chains up for transport & storage.

Note - Check valves are located on back face of some manifolds.

** Not all valves are installed in all manifold models – the following chapters will specify the relevant cartridges for each manifold



General Troubleshooting: All Manifolds

Like all hydraulic components the main enemy is contamination. Care should be taken at all times to prevent contamination entering the hydraulic circuit. Self-cleaning line filters are fitted to the tractor hoses on the pressure section of the manifold.

1. Slow down the flow of the tractor hydraulics to 20% or about 8-10gpm.
2. It may be necessary to remove extra weight such as mud build-up on discs.
3. Ensure that hydraulic fluid is travelling to the manifold
 - When the circuit flows, do the hoses move or stiffen?
 - If not, choose another SCV (selective control valve in tractor hydraulic bank) to make sure that it's not a connection issue

Identify if the problem is on the folding or unfolding sequence. Unfolding = Extend Folding = Retract

Basic Reset - Folding

This valve block is split into two circuits. One set of hoses controls the raising and lowering of the tail and modules, independent from the wing fold.

Raise the tail first. Then loosen the jam nut on the sequence valve cartridges S1 and S2. Increase valve pressure settings by screwing in S1 and S2 (clockwise) until they bottom out. Activate the folding circuit with the tractor control valve. The main wings will raise/fold. The left and right outer wings will not fold. Screw out S1 (counter clockwise) until the left outer wing folds then give it another ¼ turn. Next, the right outer wing will not fold. Screw out S2 (counter clockwise) until the right outer wing folds then give it another ¼ turn.

Expected folding time should be **no less** than three minutes. It may be necessary to adjust flow control (clockwise) so that the disc chains are not swinging as they rest into the L bracket chain carriers.

Basic Reset - Unfolding

Before unfolding, check to make sure the discs are not caught on the M brackets or other carrier arms.

Loosen the jam nut on the sequence valve cartridges S3 and S4. Screw in S3 and S4 (clockwise) until they bottom out. Now activate the unfolding circuit with the tractor control valve. The right outer wing will unfold and nothing else will move. Screw out S3 (counter clockwise) until the left outer wing unfolds; then give it another ¼ turn. Next, the main wings will not unfold. Screw out S4 (counter clockwise) until the main wings unfold, then give it another ¼ turn.

Since the valve block is split into two parts, you will need to now activate the tail circuit to lower the tail and modules.

If the above adjustments have been made and there are still problems, you may want to look at the other check valves and over/center valves.

- C1 - is the check valve to bypass around S2 (right outer wing) on the folding circuit
- C2 - is the check valve to bypass around S3 (left outer wing) on the unfolding circuit
- C3 - is the check valve to bypass around S1 (left outer wing) on the folding circuit
- C4 - is the check valve to bypass around S4 (main wing) on the unfolding circuit

If a check valve is open due to contamination, the symptom will be as though the corresponding sequence valve is open.

Further troubleshooting is outlined on page 30



Sequence Manifold Identifier for all double fold models



Manifold Part #	228712
Version	6 (2006 – 2012)
Features	Aluminum and gold anodized. 2 input hoses on bottom. 2 ports on top.
Flow Control	fixed
Model number location	Front, top right



Manifold Part #	290179
Version	7 (2012 – Aug 2013)
Features	4 sequence valves across top of front. ST valve. 2 input hoses. 6 ports on top. TR & TE 123 common porting.
Flow Control	E & R Adjustable
Model number location	Underside, rear left corner.

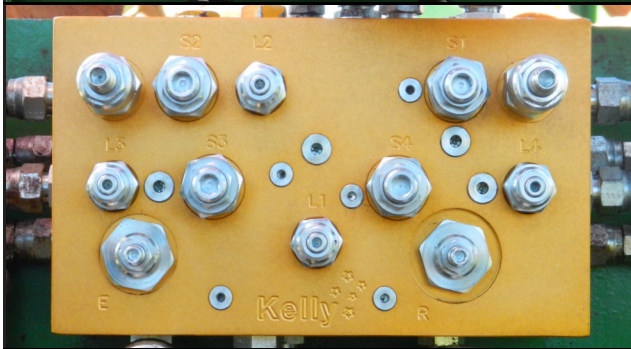

Manifold Part #	290380
Version	8 (Aug 2013)
Features	4 input hoses on bottom. PR & PL reducing valves installed. Tail hoses TE1 TR1, Module hoses ME1,2 MR1,2
Flow Control	E & R adjustable
Model number location	Top surface

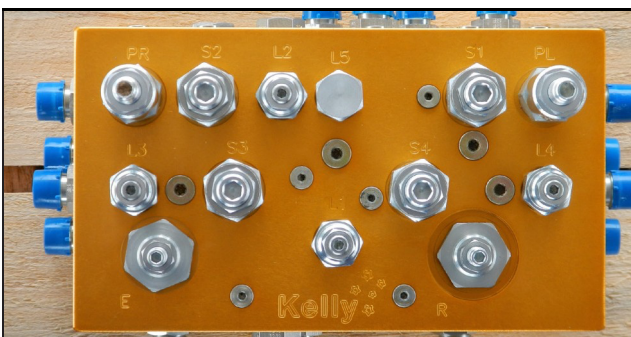

Manifold Part #	290430
Version	9 (2013 – 2014)
Features	PR & PL reducing valves installed. 4 input hoses. L5 port with plug. Tail hoses TE1 TR1, Module hoses ME1,2 MR1,2
Flow Control	E & R Adjustable
Model number location	Top surface

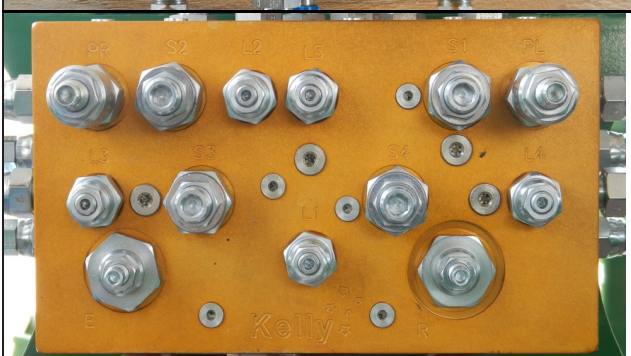

Manifold Part #	290509
Version	10 (2014 – Oct 2017)
Features	4 input hoses on bottom. PR & PL reducing valves. L5 with OC valve. Tail hoses TE1 TR1, Module hoses ME1,2 MR1,2
Flow Control	E & R adjustable
Model number location	Top surface



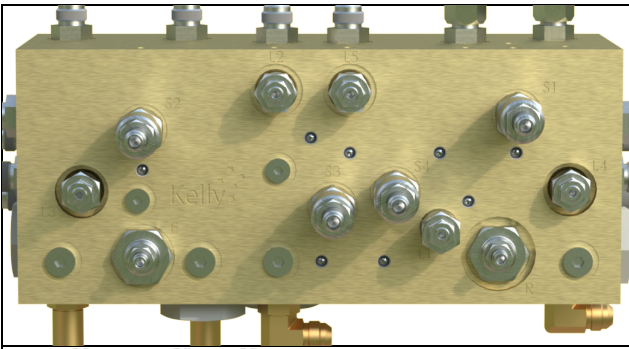

Manifold Part #	HF 111938-16
Version	12 (Oct 17 – Nov 21)
Features	4 input hoses, Tail hoses TE1 TR1, Module hoses ME1,2 MR1,2, 4 internal filter elements
Flow Control	E & R adjustable, higher flow setting
Model number location	Left hand front edge

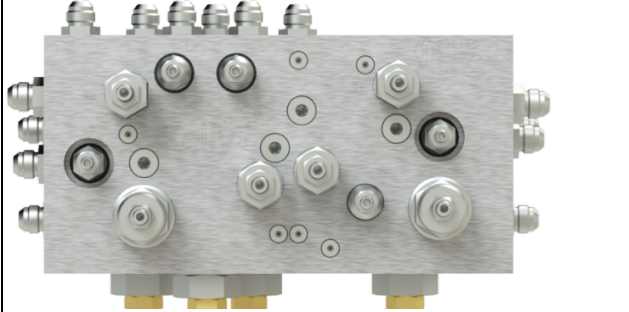

Manifold Part #	292196
Version	12.5 (Nov 21 -)
Features	4 input hoses, Tail hoses TE1 TR1, Module hoses ME1,2 MR1,2, 4 internal filter elements
Flow Control	E & R adjustable
Model number location	Front Face, Right hand top corner



292196, V12.5 - split circuit

This manifold superseded the v12 in Nov 2021 and is functionally identical but improves the internal filter design by captivating the quad ring seal.

The mounting holes are identical with v12, meaning v12.5 can replace a v12 (noting that v12.5 is 60mm (2.36") shorter than v12 and some port positions have changed, which impacts some hose lengths).

This manifold is used on any double fold machine (with inner and outer wings).

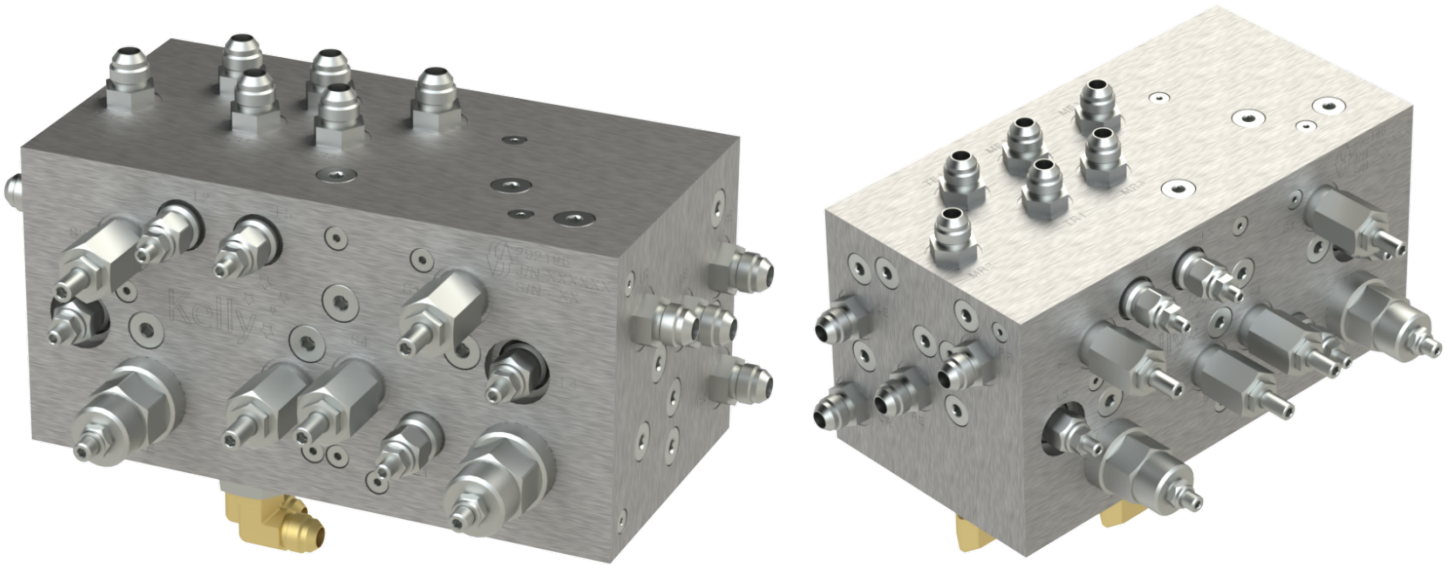

Valve block model # is on the right side of the front face of the valve block.

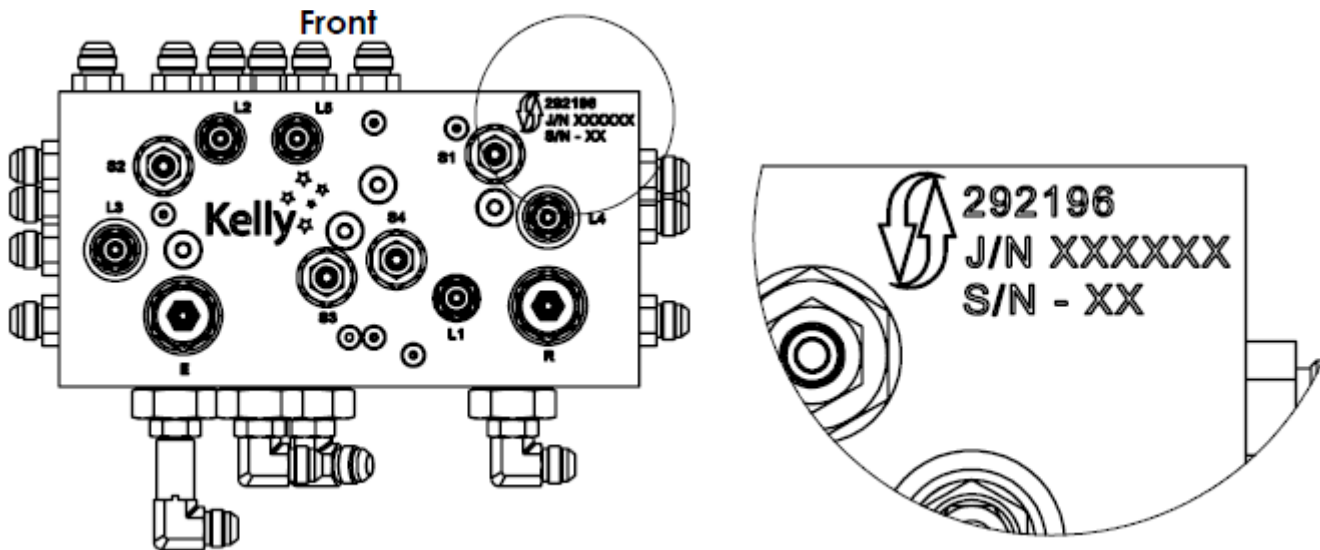

Internal filters located on the underside of valve block (see detail on following page).



V12.5 Manifold: 692196 Settings

Valve Label	Cartridge Part Number	Seat Kit Part Number	Function	Default Factory Setting Bar (PSI)	turns from bottomed out
S1**	VSCB10-21/150B	SK10-S3N-MM (HF)	Left Hand outer wing fold	150 (2175psi)	3 7/8
S2**	VSCB10-21/135B	SK10-S3N-MM (HF)	Right Hand outer wing fold	135 (1960psi)	4 3/8
S3**	VSCB10-21/135B	SK10-S3N-MM (HF)	Left Hand outer wing unfold	135 (1960psi)	4 3/8
S4**	VSCB10-21/140B	SK10-S3N-MM (HF)	Main Wing cylinders unfold	140 (2030psi)	4 1/4
E***	VCF-06-A-47L	0344-VCF-06-S	Flow Regulator (extend side)	-	2 1/3
R***	VCF-06-A-38L	0344-VCF-06-S	Flow Regulator (return side)	-	2
L1*	CB Valve C000D210031100A	S00T11ASN9000	Holds main wings from free fall	210 (3045psi)	3 1/2
L2*	CB Valve C000D330021100A	S00T11ASN9000	Holds tail in raised position	330 (4785psi)	2
L3*	CB Valve C000D210051100A	S00T11ASN9000	Holds right hand outer wing straight	210 (3045psi)	3 3/4
L4*	CB Valve C000D190031100A	S00T11ASN9000	Holds left hand outer wing straight	190 (2755psi)	3 2/3
L5*	CB Valve C060M210031100A	S00T11ASN90000V	Holds modules in raised position	210 (3045psi)	3 1/2
C1, C2, C3, C4	Check Valves VCV-10-05-10	SK10-2N-T (HF)	Bypass sequence valves	-	-

Note:

- * Valvole counterbalance valves listed above. v12 cartridges (4170740.D33002) are identical (and same settings)
- ** Taiwanese sourced sequence valves – fully interchangeable with Sterling, HydraForce, Bucher and can be fitted into the v12 and vice versa
- *** the flow cartridges in this manifold have a larger fitting, so will not fit v12 or vice versa.

ITEM NO.	Part Number	Description	Seal Kit	Port	QTY.
1	0323-S12-1212	3/4" JIC Male 3/4" UN O Male Extended 90° Elbow	0343-BG908	EXT1	1
2	0323-S90-1212	3/4" JIC Male 3/4" UN O Ring Male Adaptor	0343-BG908	All unless noted	14
3	0323-S91-1212	3/4" JIC Male 3/4" UN O Ring Male 90° Elbow	0343-BG908	RCT1, EXT2, RCT2	3
4	0341-C000D190031100A	Load Control Valve 3:1 Preset to 190 Bar	0344-S00T11ASN9000	L4	1
5	0341-C000D210031100A	Load Control Valve 3:1 Preset to 210 Bar	0344-S00T11ASN9000	L1	1
6	0341-C000D210051100A	Load Control Valve 5:1 Preset to 210 Bar	0344-S00T11ASN9000	L3	1
7	0341-C000D330021100A	Load Control Valve 2:1 Preset to 330 Bar	0344-S00T11ASN9000	L2	1
8	0341-C060M210031100A	Load Control Valve 3:1 Preset to 210 Bar, Atmospherically Vented	0344-S00T11ASN9000	L5	1
9	0341-VCF-06-A-38L	Flow Controller	0344-S00T11ASN9000V	R	1
10	0341-VCF-06-A-47L	Flow Controller	0344-VCF-06-S	E	1
11	0341-VCV-10-05-10	Check Valve	0344-VCF-06-S	C1,2,3,4	4
12	0341-VSCB10-21-135B	Pilot-Operated Sequence Cartridge	0344-SK10-2N-T	S2, S3	2
13	0341-VSCB10-21-140B	Pilot-Operated Sequence Cartridge	0344-SK10-S3N-MM	S4	1
14	0341-VCCB10-21-150B	Pilot-Operated Sequence Cartridge	0344-SK10-S3N-MM	S1	1
15	0343-240382	Filter Element Retaining Plug	0344-SK10-S3N-MM		4
16	0343-253222	Filter Location Sleeve			4
17	0343-401043	BG916 O-RING			4
18	0343-401571	Face Seal			4
19	0343-426197	Filter Element 60 Microns			4
20	0802-692196B	Dual Circuit 3 Stage Sequence Manifold V12.5 Body			1

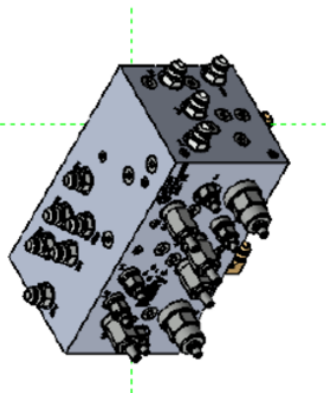
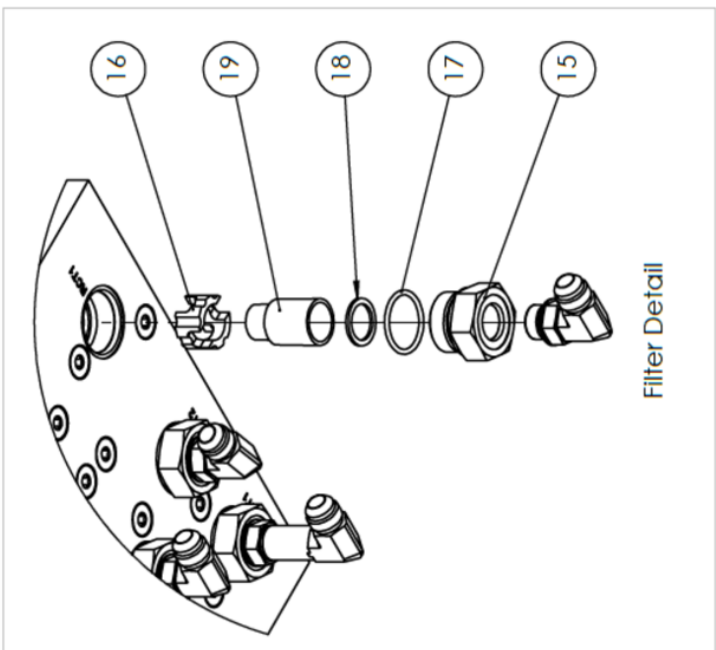
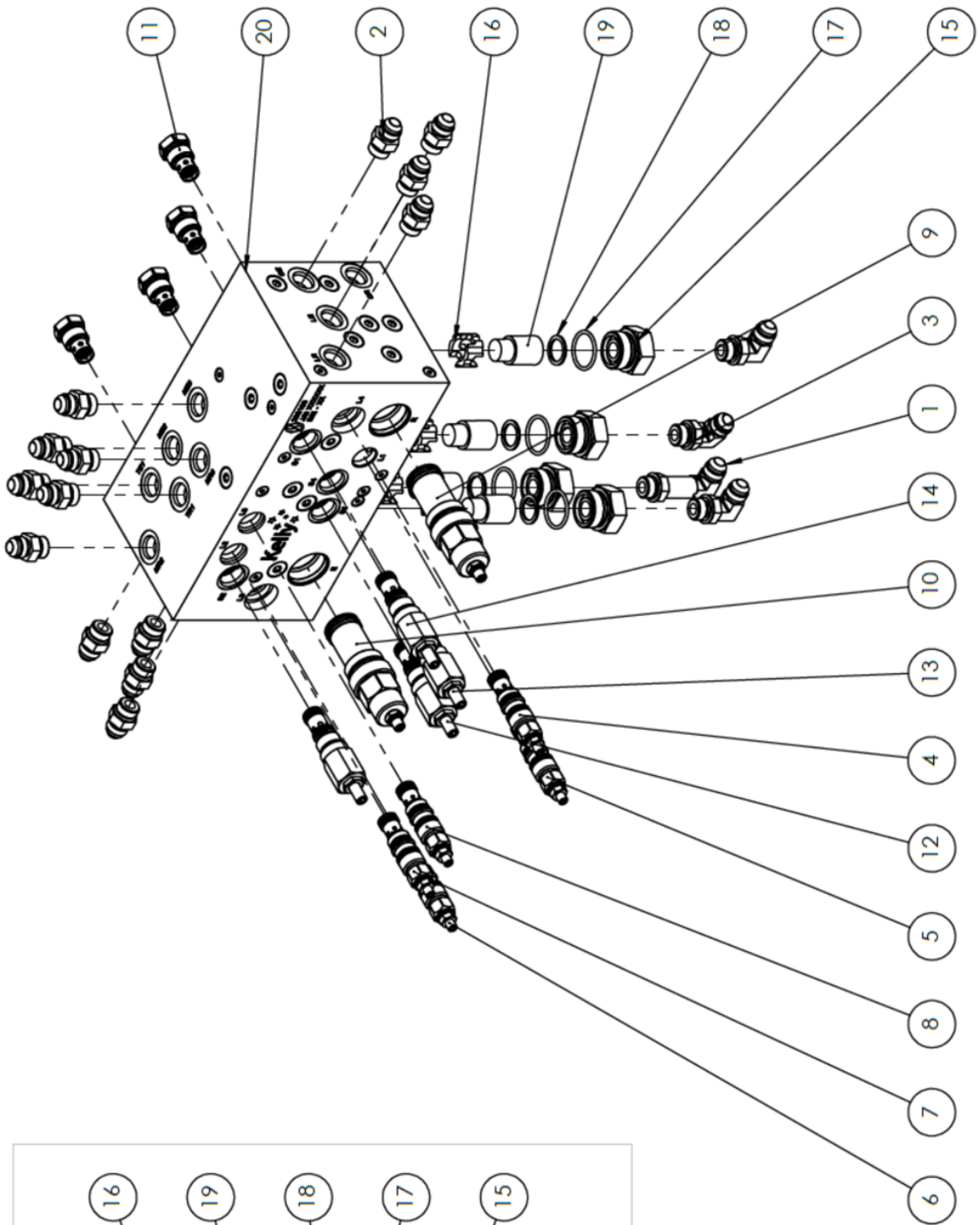

HF111938-16, v12 split circuit

This manifold is referred to as the v12 and is used on all models with double-folding wings. This manifold is used on any double fold machine (with inner and outer wings) from Oct 2017 till Nov 2021.

The model # of the valve block is on the right end of the valve block, toward the front.

Make sure tail hoses are on TR1 and TE1.

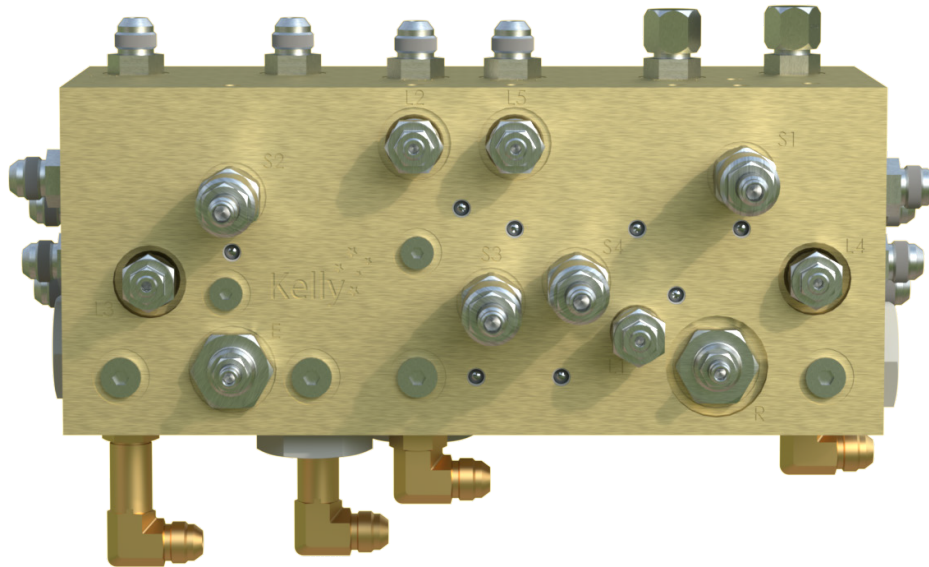

Internal filters are located on left and right ends (for the wing circuit) and underside of valve block.

Wing folding issues have been associated with the filter design in this manifold. Please refer to Technical Bulletin 91a (see page 17) for guidance on troubleshooting this issue and instructions for replacing the springs with an aluminium insert on the inside of the filter cap. Watch for split/damaged seals/quad-rings as contamination in the F or R flow regulators in particular.

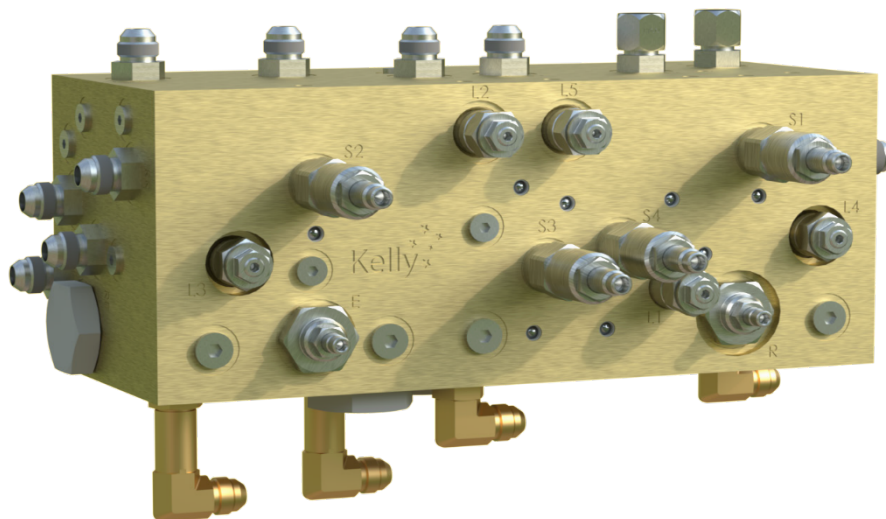

V12 Manifold: HF111938-16 Settings

Valve Label	Cartridge Part Number	Seal Kit Part Number	Function	Default Factory Setting Bar (psi)	turns from bottomed out
S1	PS10-S3801A-0-N-30/M150	SK10-S3N-MM	Left Hand outer wing fold	150 (2175psi)	3/16
S2	PS10-S3801A-0-N-30/M135	SK10-S3N-MM	Right Hand outer wing fold	135 (1960psi)	3/8
S3	PS10-S3801A-0-N-30/M135	SK10-S3N-MM	Left Hand outer wing unfold	135 (1960psi)	3/8
S4	PS10-S3801A-0-N-30/M140	SK10-S3N-MM	Main Wing cylinders unfold	140 (2030psi)	5/16
E*	FR12-23A-0-N/M47	SK12-2N-M	Flow Regulator (extend side)	-	fixed
R*	FR12-23A-0-N/M38	SK12-2N-M	Flow Regulator (return side)	-	fixed
L1	CB Valve 4170740.D21003	S00T11ASN9000	Holds main wings from free fall	210 (3045psi)	3 1/2
L2	CB Valve 4170740.D33002	S00T11ASN9000	Holds tail in raised position	330 (4785psi)	2
L3	CB Valve 4170740.D21005	S00T11ASN9000	Holds right hand outer wing straight	210 (3045psi)	3 3/4
L4	CB Valve 4170740.D19003	S00T11ASN9000	Holds left hand outer wing straight	190 (2755psi)	3 2/3
L5	CB Valve 417092A.M21003	S00T11ASN9000V	Holds modules in raised position	210 (3045psi)	3 1/2
C1, C2, C3, C4	Check Valves CV10-20-0-N-5	SK10-2N-T	Bypass around sequence valves	-	-

Turn the valve clockwise gently, till it bottoms out, then counter-clockwise the number of revolutions listed

* Compared with older manifolds, these flow regulators have increased capacity to 38LPM and 47LPM respectively

ITEM NO.	Part Number	Description	Seal Kit	Port	QTY.
1	0323-S12-1212	3/4" JIC Male 3/4" UN O Male Extended 90° Elbow	0343-BG908	EXT1, RCT2	2
2	0323-S65-12	3/4" JIC Female Cap		ME3, MR3	2
3	0323-S90-1212	3/4" JIC Male 3/4" UN O Ring Male Adaptor	0343-BG908	All, unless noted otherwise	14
4	0323-S91-1212	3/4" JIC Male 3/4" UN O Ring Male 90° Elbow	0343-BG908	EXT2, RCT1	2
5	0341-4170740-D19003	3:1 Pilot Ratio Counterbalance Valve	0344-S00T11ASN9000	L4	1
6	0341-4170740-D21003	3:1 Pilot Ratio Counterbalance Valve	0344-S00T11ASN9000	L1	1
7	0341-4170741-D21005	5:1 Pilot Ratio Counterbalance Valve	0344-S00T11ASN9000	L3	1
8	0341-4170740-D33002	2:1 Pilot Ratio Counterbalance Valve	0344-S00T11ASN9000	L2	1
9	0341-417092A-M21003	3:1 Pilot Ratio Counterbalance Valve (ATM Vented)	0344-S00T11ASN9000V	L5	1
10	0341-CV10-20-0-N-5	Check Valve 5PSI Spring	0344-SK10-2N-T	C1, C2, C3, C4	4
11	0341-FR12-23A-0-N-M38	Regulator-Pressure-Compensated (set to 38Lpm)	0344-SK12-2N-M	R	1
12	0341-FR12-23A-0-N-M47	Regulator-Pressure-Compensated (set to 47Lpm)	0344-SK12-2N-M	E	1
13	0341-PS10-S3801A-0-N-30-M135	Pilot-Operated Sequence Cartridge	0344-SK10-S3N-MN	S2, S3	2
14	0341-PS10-S3801A-0-N-30-M140	Pilot-Operated Sequence Cartridge	0344-SK10-S3N-MN	S4	1
15	0341-PS10-S3801A-0-N-30-M150	Pilot-Operated Sequence Cartridge	0344-SK10-S3N-MN	S1	1
16	0343-4170909	Port Plug 4170909	0343-BG916		4
17	0343-4170910	Spring 4170910			4
18	0343-4170911	Spring 4170911			4
19	0343-4170912	Filter Element 4170912			4
20	0343-4170913	Seal 4170913			4
21	0802-HF111938-16-B	Dual Circuit 3 Stage Sequence Manifold V12 Body			1

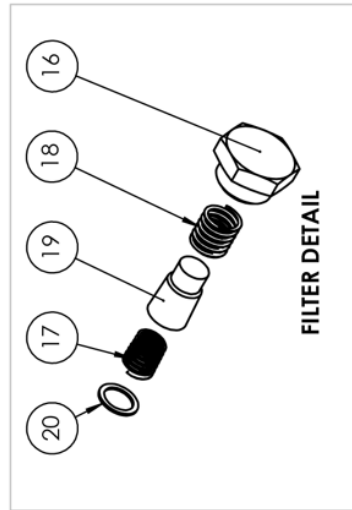

FILTER DETAIL

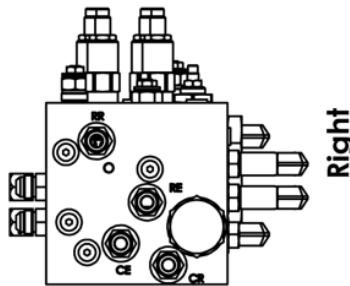
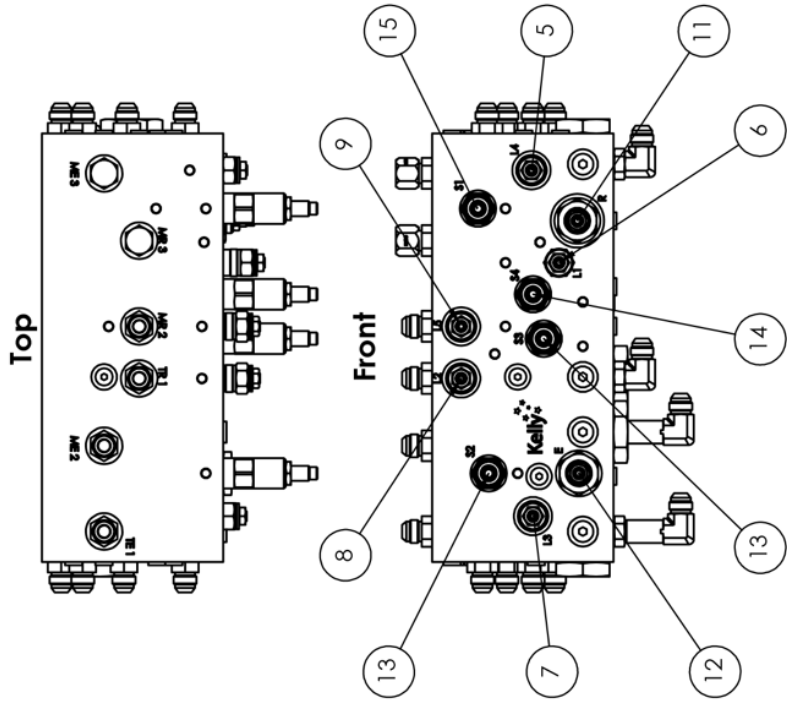

Right

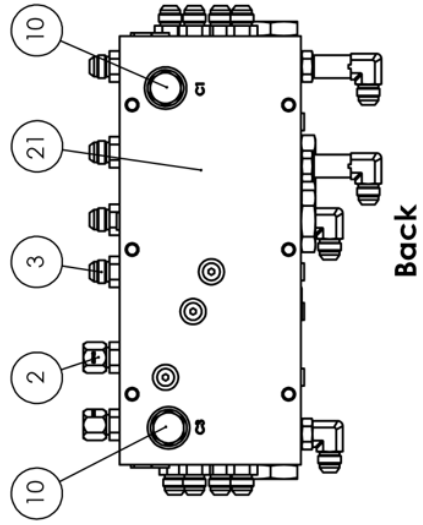

Back

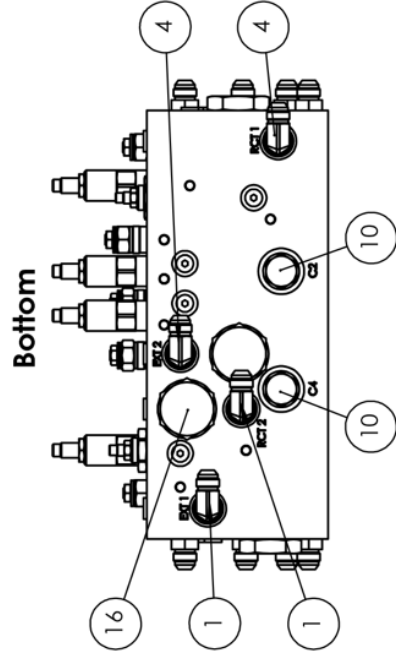

Bottom

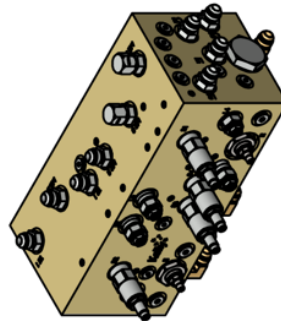

Top

Front

Left

Technical Bulletin 91a: V12 Manifold Filter Seal

Overview:

Machines fitted with the HF111938-16 (v12) hydraulic sequence control manifold may experience issues with folding that are related to the filter seal dislodging. The seal is then easily split and the resulting debris is trapped in the cartridge cavities.

Further diagnostic guidelines are provided in **appendix A** (see page 38).

Symptoms

- Slow OR no OR out of sequence folding / unfolding
- No movement when hydraulic circuit is engaged

Before addressing the filters:

- Ensure that hydraulic fluid is travelling to the manifold
 - When the circuit flows, do the hoses move or stiffen?
 - If not, choose another SCV (selective control valve in tractor hydraulic bank) to make sure that it's not a connection issue
- Check for debris in the nipple of the quick release couplings to the tractor

Parts Provided:

Components		
Part Number	Description	Qty
0343-252208	Insert for v12 Filter	2
0343-4170913	Seal 4170913	2



0343-252208

Tools Required:

- 1 3/4" spanner (which is also the machine chain tension adjusting spanner)
- O-ring pick
- 7/8" or 22mm spanner
- Appropriate protective apparel/equipment for hydraulic oil
- Hammer and centre-punch



In the event of a field **BREAKDOWN**:

Remove filter and seal (for a quick fix to continue operating after breakdown)

To continue working, simply remove the filter components on each end of the manifold (highlighted in blue below). The tractor's current filter is sufficient for oil cleanliness. Please continue good hygiene of the quick-release couplers.

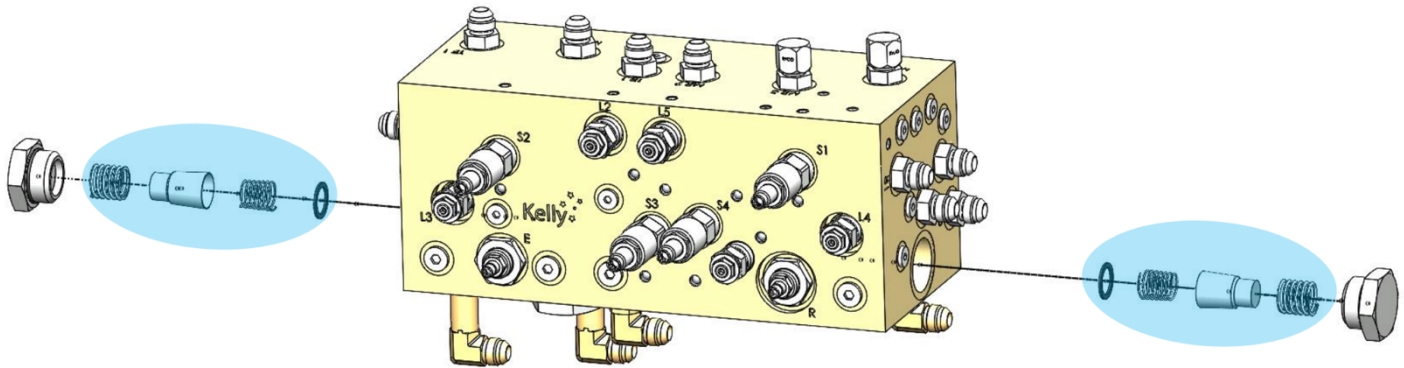

PREVENTATIVE Remedial Action:

Remove filter springs and install component (the preferred option of keeping filter)

Your local Kelly representative will supply the filter insert and replacement seals (0343-252208 and 0343-4170913 respectively).

Remove the two springs from the filter assemblies and replace with the aluminum insert, according to the following procedure:

Procedure:

- ⚠ Support the outer wings with a suitable stand to prevent oil loss when hoses are detached
- ⚠ Check for pressure in hoses when unscrewing hose ends

Be aware that there will be oil leakage. Ensure you have suitable options to contain the spill.

1. For the right-side filter, unscrew the hose-ends in ports RE and CR (if folded, cover CR hose-end with a rag to suppress oil splatter as pressure is released).
For the left side, unscrew hose LE only (access is limited). Remove adaptors.



- Unscrew cap on filter. **NOTE: this takes significant torque. Beware of surrounding fittings!**
- Remove retainer spring, filter and internal spring. Discard the springs.

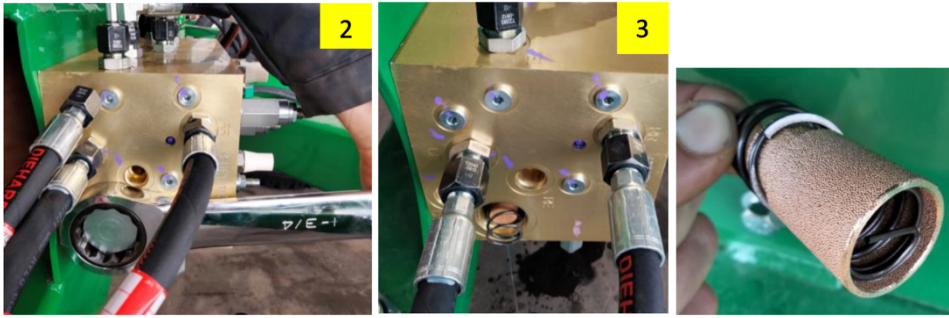

- Inspect the quad ring seal in the base of the cavity. Is it dislodged? If it is damaged or split, remove the seal and any visible debris. Proceed to check *both* flow control cartridge (labelled R (RHS) and E (LHS) on the front face of the manifold).

If the rubber cannot be removed from the valve, contact Kelly for a replacement flow regulator.

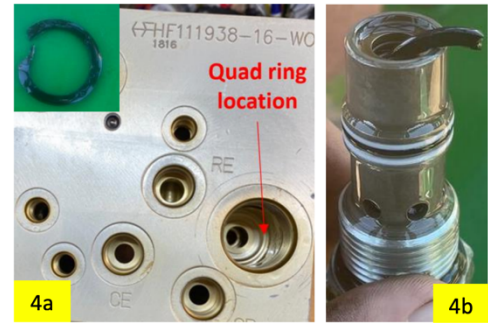

- If the seal is undamaged, then re-insert the filter element (without either spring). **Press the filter onto the seal and wriggle it to make sure it is located.**

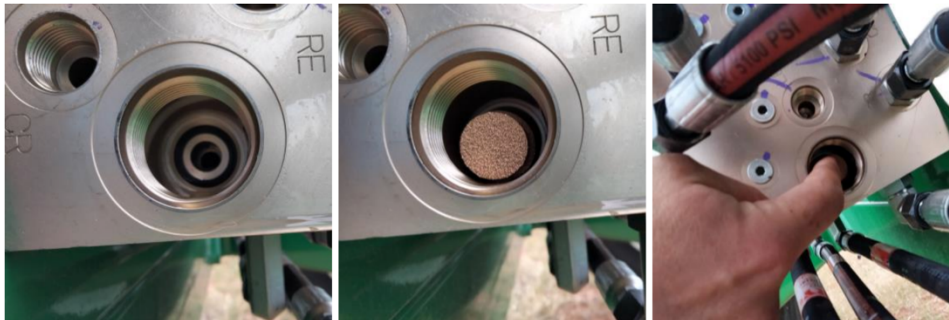

- Drop the provided aluminum insert into the head of the filter cap.

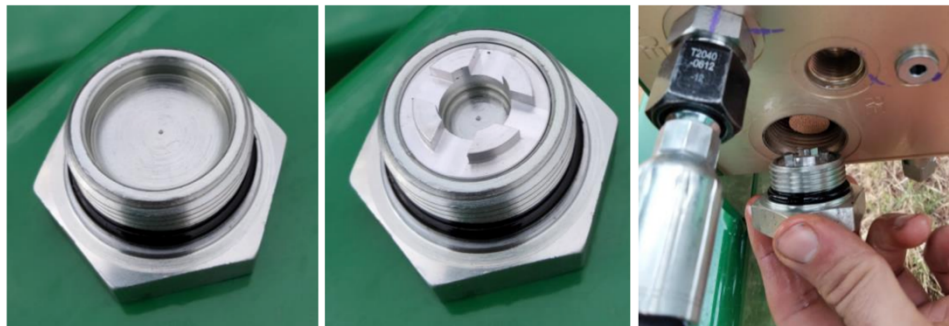

- Finger tighten the filter cap first. If it becomes tight before the O-ring on the cap engages with the manifold, then the filter element is likely to have moved out of line. Unscrew and repeat.



8. Use the ring end of the spanner to tighten the cap.
9. Use a centre-punch to mark a point on the outside of the filter cap, to indicate that this procedure has been carried out on your manifold.
10. Reattach adaptors and the hoses.

Contact Kelly with the following information:

- The serial number of your machine
- The code on the manifold (see red circle on diagram, right)
- The symptoms

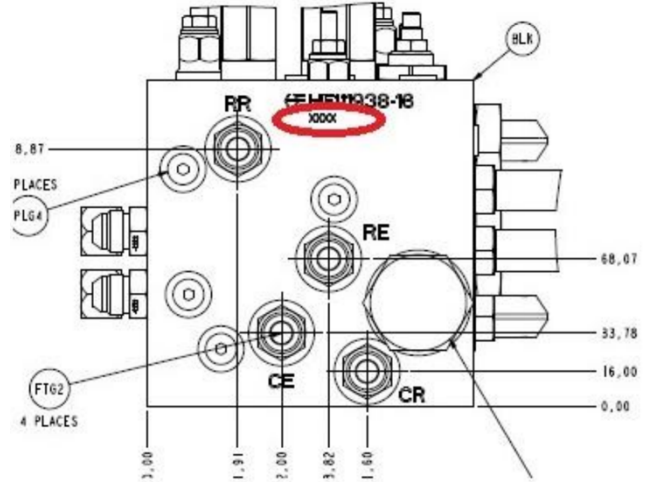

If the folding sequence needs to be reset, please refer to the factory settings on page 14.



290509, v10 - split circuit

The v10 manifold started in 2014 and continued to feature the PR and PL valves, though the schematic is identical with the v12. It has been used on the 40, 45, 50, 60, 62, 65 Kelly Diamond Harrow.

Valve block model # is on the top of the valve block, toward the back.

L5 has a counterbalance valve installed. Make sure tail hoses are on TR1 and TE1. Issues on this manifold often relate to PR and PL.

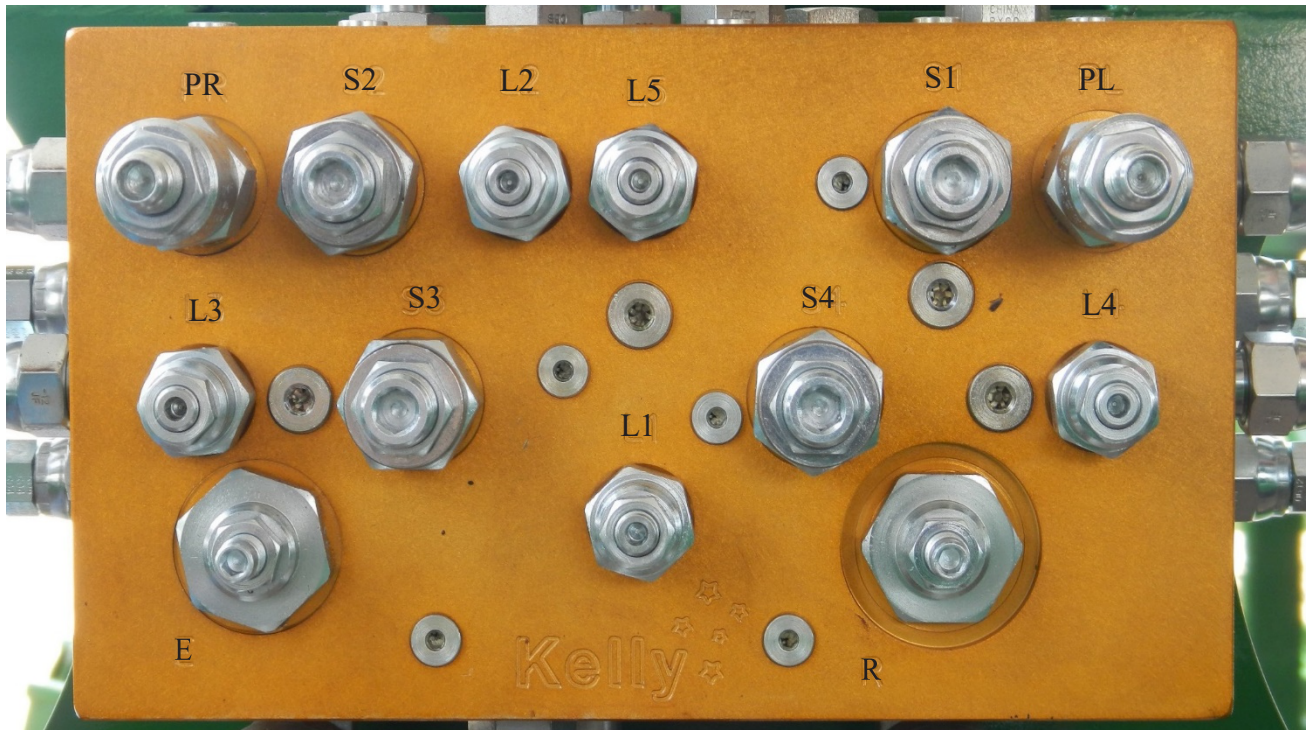

Valve Label	Cartridge Part Number	Function	Default Factory Setting turns from bottomed out
S1	PSVP-10-N-S-0-30	Left Hand outer wing fold	2-1/2
S2	PSVP-10-N-S-0-30	Right Hand outer wing fold	3-1/8
S3	PSVP-10-N-S-0-30	Left Hand outer wing unfold	3-1/8
S4	PSVP-10-N-S-0-30	Main Wing cylinders unfold	2-3/4
E	FR12-23A-0-N/M32	Flow Regulator (extend side)	-
R	FR12-23A-0-N/M23	Flow Regulator (return side)	-
L1	CB Valve 6114063-CBCA-LHN	Holds main wings from free fall	1/2
L2	CB Valve CBCL-LJN	Holds tail in raised position	
L3	CB Valve 6114056-CBCG-LJN	Holds right hand outer wing straight	2-1/8
L4	CB Valve 6114056-CBCG-LJN	Holds left hand outer wing straight	2-1/4
L5	CB Valve CACA-LHN	Holds modules in raised position	1-5/8
PR, PL*	PR10-36A-0-N-30	Pressure control of main wings	-
C1 - C4	Check Valves CV10-20-0-N-5	Bypass around sequence valves	-

*VGR-10-14 is the alternative part number for the PR10's.



290430, v9 - split circuit

In 2013, this v9 manifold introduced the L5 porting along with the pressure relief cartridges PR and PL. This manifold is used on any double fold machine (with inner and outer wings). The valve block model # is on the top of the valve block, toward the back.

Make sure L5 has a cavity plug in it. Make sure tail hoses are on TR1 and TE1. The module chains are known to creep with this manifold.

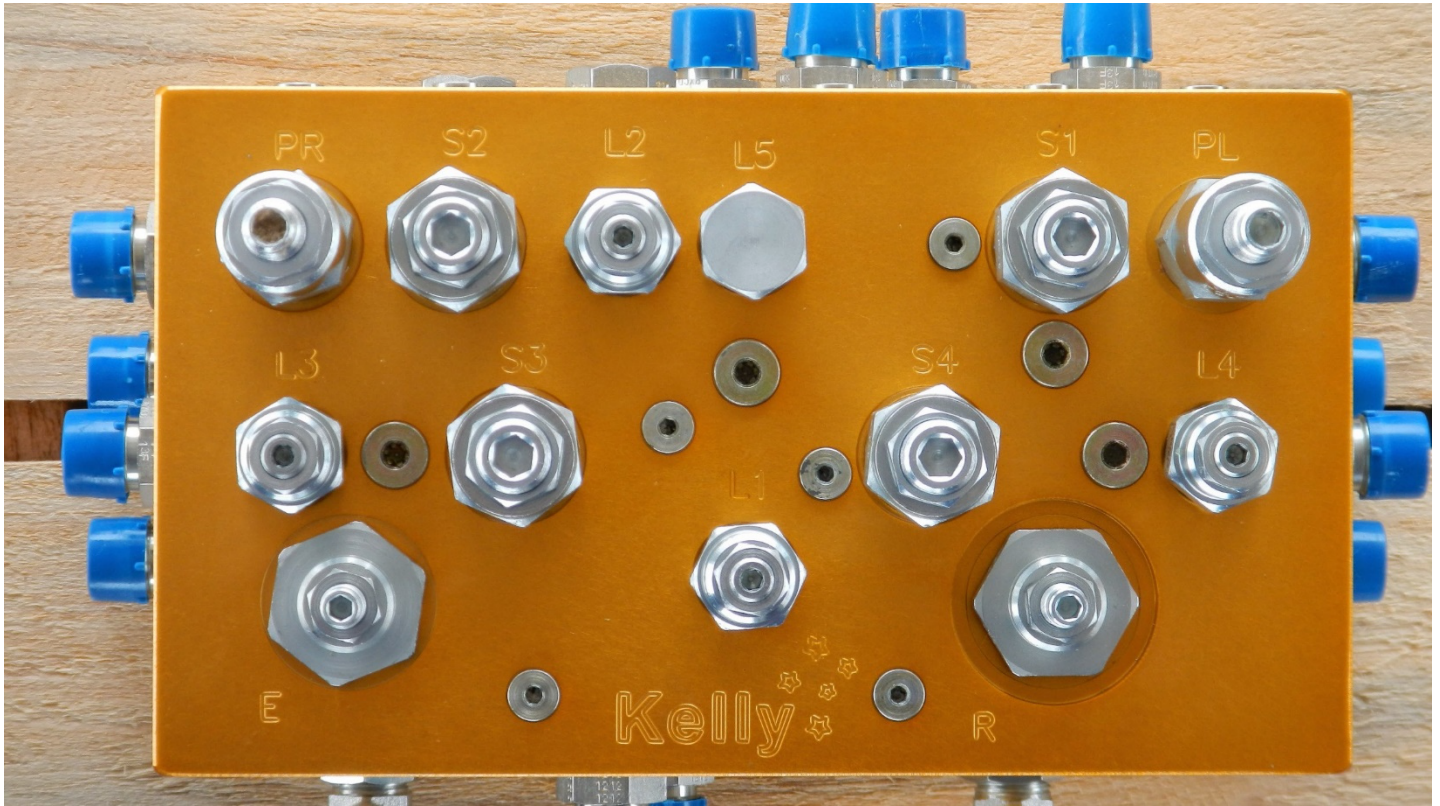

Valve Label	Cartridge Part Number	Function	Default Factory Setting turns from bottomed out
S1	PSVP-10-N-S-0-30	Left Hand outer wing fold	2-1/2
S2	PSVP-10-N-S-0-30	Right Hand outer wing fold	3-1/8
S3	PSVP-10-N-S-0-30	Left Hand outer wing unfold	3-1/8
S4	PSVP-10-N-S-0-30	Main Wing cylinders unfold	2-3/4
E	FR12-23A-0-N/M32	Flow Regulator (extend side)	-
R	FR12-23A-0-N/M23	Flow Regulator (return side)	-
L1	CB Valve 6114063-CBCA-LHN	Holds main wings from free fall	1-3/4
L2	CB Valve CBCL-LJN	Holds tail in raised position	
L3	CB Valve 6114056-CBCG-LJN	Holds right hand outer wing straight	2-1/8
L4	CB Valve 6114056-CBCG-LJN	Holds left hand outer wing straight	2-1/4
L5	CB Valve CACA-LHN	Holds modules in raised position	1-1/8
PR, PL*	PR10-36A-0-N-30	Pressure control of main wings	-
C1 - C4	Check Valves CV10-20-0-N-5	Bypass around sequence valves	-

*VGR-10-14 is the alternative part number for the PR10's.



290380, v8 - split circuit

The v8 is the first manifold with a split circuit to allow tail to raise and lower separately. Introduced in Aug 2013, it is used on the 40', 45', 50', 60', 62, 65' Kelly Diamond Harrow.

On this manifold, the tail and modules share L2. It became evident that the module chains creep.

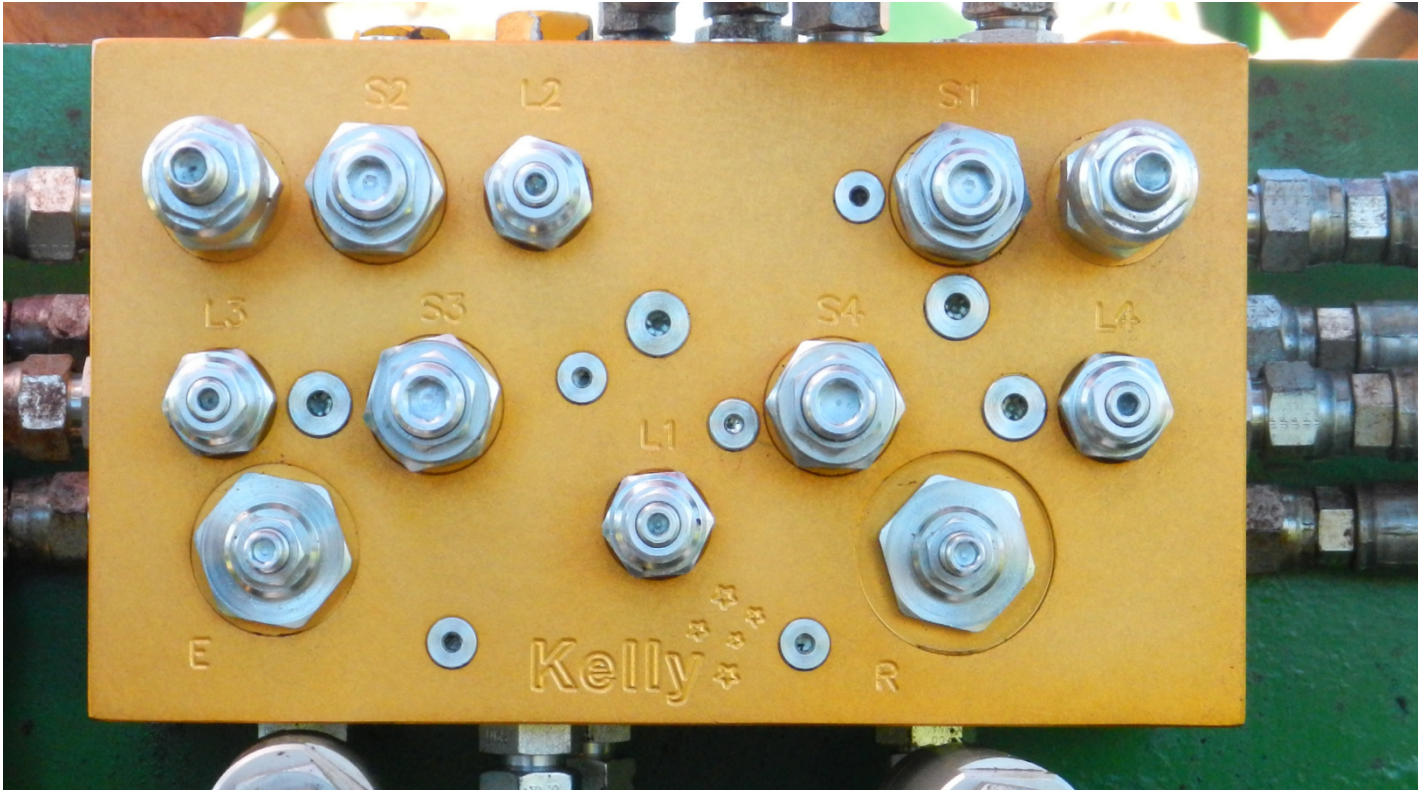

Valve Label	Cartridge Part Number	Function	Default Factory Setting turns from bottomed out
S1 **	PSVP-10-N-S-0-30	Left Hand outer wing fold	3/16
S2 **	PSVP-10-N-S-0-30	Right Hand outer wing fold	3/8
S3 **	PSVP-10-N-S-0-30	Left Hand outer wing unfold	3/8
S4 **	PSVP-10-N-S-0-30	Main Wing cylinders unfold	5/16
E	FR12-23A-0-N/M32	Flow Regulator (extend side)	-
R	FR12-23A-0-N/M23	Flow Regulator (return side)	-
L1	CB Valve 6114063-CBCA-LHN	Holds main wings from free fall	1-3/4
L2	CB Valve CBCL-LJN	Holds tail in raised position	
L3	CB Valve 6114063-CBCA-LHN	Holds right hand outer wing straight	1-3/4
L4	CB Valve 6114063-CBCA-LHN	Holds left hand outer wing straight	1-1/2
PR, PL *	PR10-36A-0-N-30	Pressure control of main wings	-
C1 - C4	Check Valves CV10-20-0-N-5	Bypass around sequence valves	-

*VGR-10-14 is the alternative part number for the PR10's.

**PSVP-10-N-S-0-30 is the current equivalent & interchangeable sequence valve



290179, v7 - split circuit

This manifold in 2012, featured and ST tail sequence cartridge. It remained a single circuit. This manifold used unique cartridges that don't fit anything else.

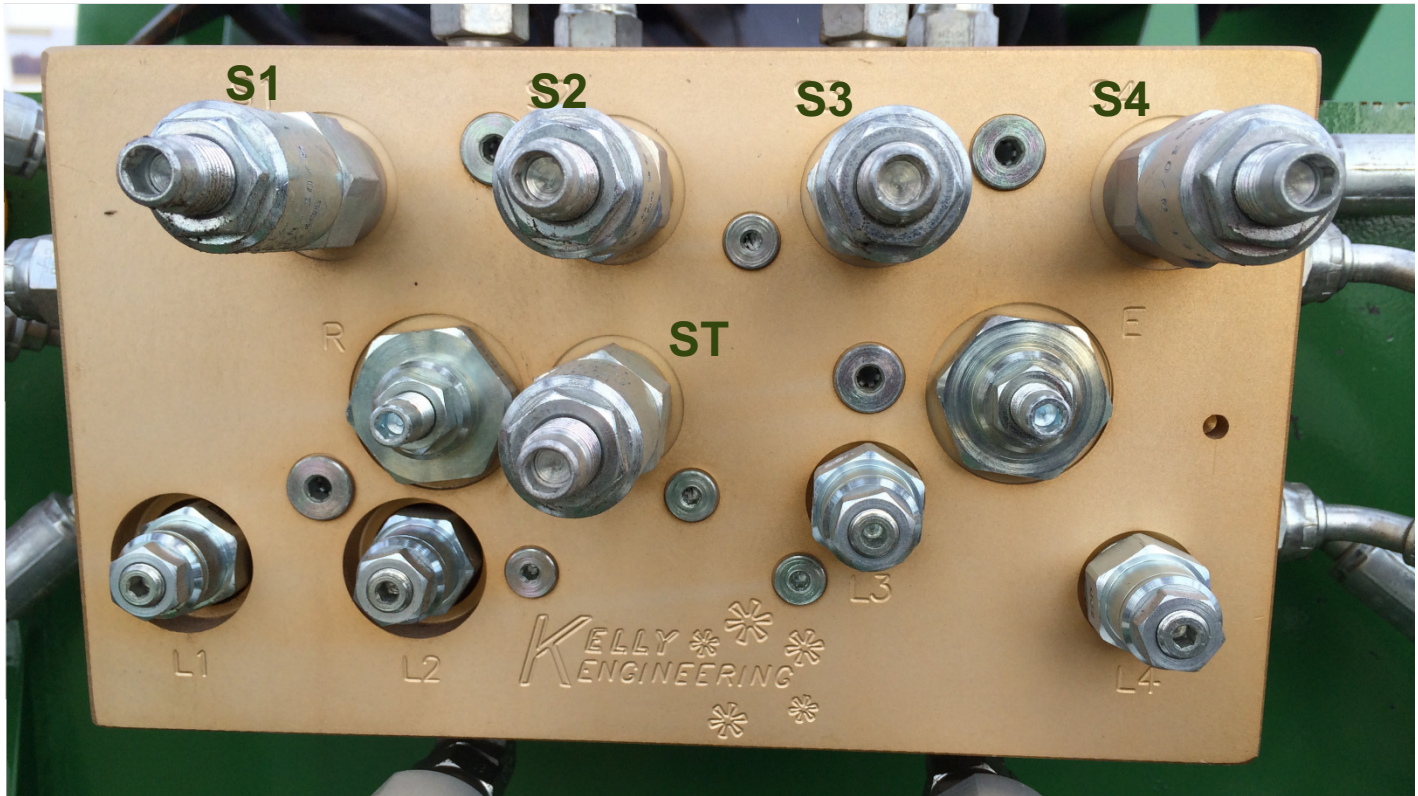

Folding problems

This valve block has a sequence valve ST to control the tail raising function. The sequence operates as ST then S1 then S2

Loosen the jam nut on the sequence valve cartridges - ST, S1 and S2. Increase valve pressure settings by screwing in ST, S1 and S2 (clockwise) until they bottom out. Activate the folding circuit with the tractor control valve.

The Tail and modules will raise up. Nothing else will move. Screw out ST (counter clockwise) until the main wings raise/fold. The left and right outer wings will not fold. Screw out S1 (counter clockwise) until the left outer wing folds then give it another ½ turn. Next, the right outer wing will not fold. Screw out S2 (counter clockwise) until the right outer wing folds then give it another ½ turn.

Unfolding problems

Before unfolding, check to make sure the discs are not caught on the M brackets or other carrier arms.

Loosen the jam nut on the sequence valve cartridges S3 and S4. Screw in S3 and S4 (clockwise) until they bottom out. Now activate the unfolding circuit with the tractor control valve. The right outer wing will unfold and nothing else will move. Screw out S3 (counter clockwise) until the left outer wing unfolds then give it another ½ turn. Next, the main wings will not unfold. Screw out S4 (counter clockwise) until the main wings unfold, then give it another ½ turn.

The tail and modules should follow last of all. Increase pressure on L2 if tail comes down too soon. (counter-clockwise to increase pressure)



The sequence cartridge (PS10-36A-0-N-30) is unique to this manifold and cannot be interchanged with any of the other manifold sequence cartridges.

Valve Label	Cartridge Part Number	Function	Default Factory Setting turns from bottomed out
S1 **	PS10-36A-0-N-30	Left Hand outer wing fold	5-1/2
S2 **	PS10-36A-0-N-30	Right Hand outer wing fold	6
S3 **	PS10-36A-0-N-30	Left Hand outer wing unfold	6
S4 **	PS10-36A-0-N-30	Main Wing cylinders unfold	6
ST **	PS10-36A-0-N-30	Tail raise - fold	5-1/2
E	FR12-23A-0-N/M32	Flow Regulator (extend side)	-
R	FR12-23A-0-N/M23	Flow Regulator (return side)	-
L1	CB Valve 6114063-CBCA-LHN	Holds main wings from free fall	1-3/4
L2 *	CB Valve CBCL-LJN	Holds tail in raised position	
L3	CB Valve 6114063-CBCA-LHN	Holds right hand outer wing straight	1-3/4
L4	CB Valve 6114063-CBCA-LHN	Holds left hand outer wing straight	1-1/2
C1 - C4	Check Valves CV10-20-0-N-5	Bypass around sequence valves	-

The number of turns is measured from bottom the valve out and screwing anticlockwise.

* CBCL-LJN has a unique cavity configuration

** PS10-36A-0-N-30 has a unique cavity configuration. The only sequence valve that is not interchangeable with all others.

L1 & L2 are related...if you over do one it will affect the other one.

If the above adjustments have been made and there are still problems, you may want to look at the other check valves. If a check valve is open due to contamination, the symptom will be as though the corresponding sequence valve is open.

When multiple tractors are to be used, set valves to the tractor that has the lowest pressure (most times the oldest tractor).



228712, v6

(Also goes by the part numbers: 288712P from Sept-12 and 288712R from Nov-12).

This 3-stage kickdown sequence manifold ran for around six years from 2006 on models including the 40', 45', 50', 60', 62' Kelly Diamond Harrow.

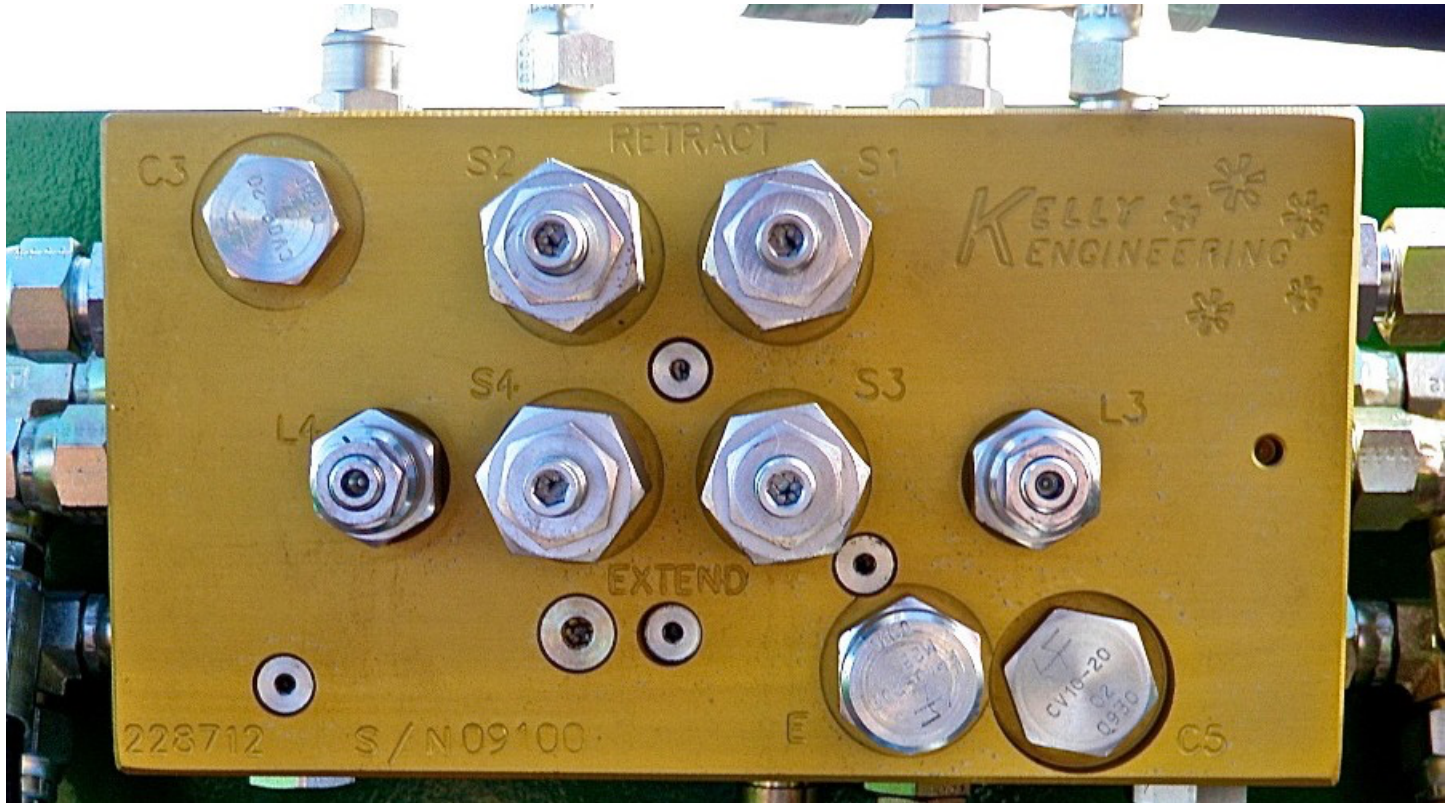

Valve Label	Cartridge Part Number	Function	Default Factory Setting turns from bottomed out
S1 *	B04C3H-Z-N-587	Left Hand outer wing fold	2-1/2
S2 *	B04C3H-Z-N-587	Right Hand outer wing fold	3-1/4
S3 *	B04C3H-Z-N-587	Left Hand outer wing unfold	3-1/4
S4 *	B04C3H-Z-N-587	Main Wing cylinders unfold	3-1/4
E	FR10-20F-0-N/M23	Flow Regulator (extend side)	-
R	FR10-20F-0-N/M12	Flow Regulator (return side)	-
L1	CB Valve 6114063-CBCA-LHN	Holds main wings from free fall	1/2
L2	CB Valve 6114063-CBCA-LHN	Holds tail in raised position	1/2
L3	CB Valve 6114063-CBCA-LHN	Holds right hand outer wing straight	1-3/4
L4	CB Valve 6114063-CBCA-LHN	Holds left hand outer wing straight	1-1/2
C1 - C4	Check Valves CV08-20-0-N-04	Bypass around sequence valves	-
C5	Check Valve CV10-20-0-N-5	Bypass around sequence valve	-

* PSVP-10-N-S-0-30 is the current equivalent & interchangeable sequence valve
505095 is also interchangeable with B04C3H-Z-N-587. The Hydraforce equivalent is KS10-S3201A-0-N-30.



227654 / 287654

This is the manifold that existed between 2001 and 2005. The circuitry is similar to v6, which came next.

On some machines, the manifold may be flipped and mounted on the front of the centre frame - so it may appear that it is mounted upside down.



Valve Label	Cartridge Part Number	Function	Default Factory Setting turns from bottomed out
S1 *	B04D3H-Z-N	Left Hand outer wing fold	5-1/4
S2 *	B04D3H-Z-N	Right Hand outer wing fold	6
S3 *	B04D3H-Z-N	Left Hand outer wing unfold	5
S4 *	B04D3H-Z-N	Main Wing cylinders unfold	5
E	J04E2-Z-N	Flow Regulator (extend side)	9-1/4
R	J04E2-Z-N	Flow Regulator (return side)	6-1/2
	CB Valve E2B040-Z-N	Holds main wings from free fall	4-1/6
	CB Valve E2B040-Z-N	Holds tail in raised position	3-1/4
	CB Valve E2A040-Z-N	Holds right hand outer wing straight	

* PSVP-10-N-S-0-30 is the standard sequence valve that can be retrofitted to all manifolds except version 7. 505095 is also interchangeable with B04C3H-Z-N-587. The Hydraforce equivalent is KS10-S3201A-0-N-30.



Model 30

The Model 30 is a simple single fold machine. The manifold also controls the folding of the tail and short chain modules. Some iterations of this manifold had a sequence valve for the tail, but most relied on the OC cartridge and back pressure to manage the sequencing. The most recent manifolds split the tail circuit.

The manifold part numbers include 289848 from Jun 2011, and 290421 from Oct 2013.



Figure 1

L O/C

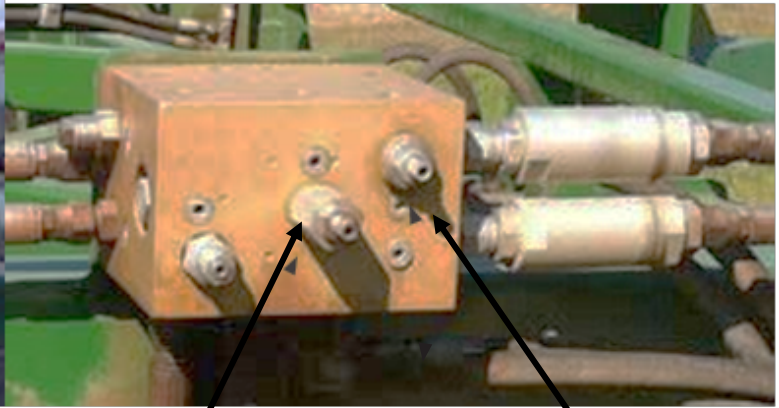

Figure 2

TAIL SEQUENCE VALVE

R O/C

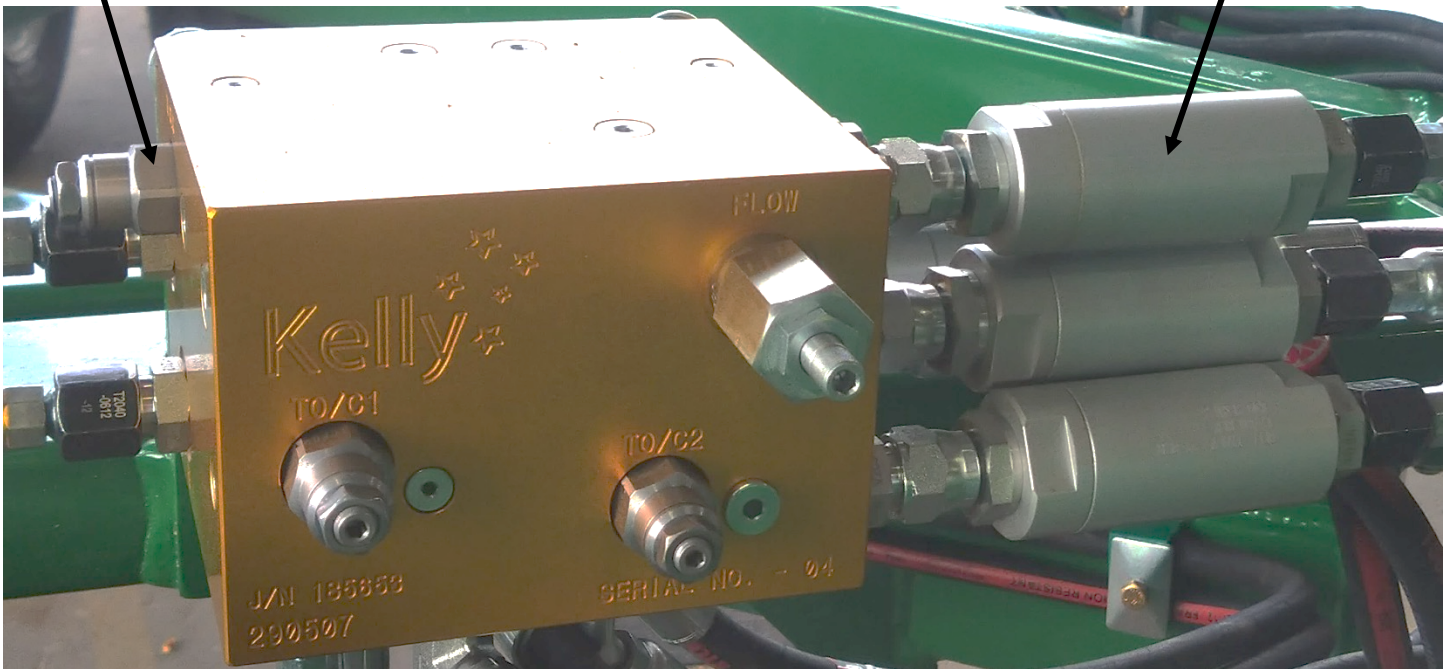

Figure 3



Factory Settings

If attempts have been made to adjust valves without the knowledge of proper valve operations and settings, it may be best to return to the factory settings.

Bottom out the valves (clockwise) and then back out (counter-clockwise):

- Left wing Over/Center (L O/C) 1 ¾ turns out
- Right wing Over/Center (R O/C) 1 ¾ turns out
- Tail Over/Center (T O/C1 & 2) 2 ¼ turns out

The counterbalance cartridge is 6114063-CBCA-LHN.

Folding

The tail and modules should come up first. If there is a plug in the S1 port, then move on to the Unfolding instructions (see figure 1). If the valve block is equipped with a sequence cartridge in the S1 port (figure 2), then loosen the jam nut on the sequence valve cartridges. With a 5mm Allen wrench, screw in ST (clockwise) until it bottoms out. (S1 is only used to control the folding circuit while the T O/C over/center valve is used to control the tail while unfolding). Activate the folding circuit with the tractor control valve. The tail will raise/fold. The wings will not raise/fold. Screw out S1 (counter clockwise) until the wings start to fold then give it another ½ turn.

In newer models (figure 3), the tail circuit is independent of the wings, ie there are two pairs of hoses connecting the valve body to the tractor remotes.

The Tail and Module OC valves hold those items in position, either fully or partially raised.

Unfolding

The tail should go down last.

If the tail does not go down last, then loosen the jam nut on the T O/C over/center valve cartridges. Set this valve at or about 2 ¼ turns out.

O/C valves are turned clockwise to decrease pressure and counter-clockwise to increase pressure. This is backwards to how it seems like it should be.

On newer models it doesn't matter in which order the tail or modules come down, so long as this is after the wings are unfolded fully via the wing fold circuit. If tail or modules creep down during storage, increase the pressure (screw the valve counterclockwise 1/2 turn).



Trouble Shooting

Problem with:	Symptom	Page
Unfolding	Right wing won't rise from folded position	31
	Center cylinders extend before outer wings are both straight (vertical)	31
	Right wing rises but left wing won't rise	32
	Both wings stand vertical then stop	32
	No movement at all	33
	Sequence was working but becomes erratic	33
Folding	No movement at all	34
	Both main wings stand vertical then left wing wont fold	34
	Left hand outer wing folds before both inner wings are vertical	35
	Right hand outer wing folds before both inner wings are vertical	35
	Main wings fold, left outer wing folds the right outer wing stands vertical	35
	Outer wings collide when folding	36
	Left outer wing stands vertical and right outer folds over	36
	Sequence was working but becomes erratic	36
Working	Wings sag in middle when working	37
V12 Manifold	Establishing hydraulic flow to the valve block	38
Unresolved	Contact service agent or manufacturer	40

Unfolding

During unfolding the following sequence must be observed.

1. Lower front tongue assembly to working height
2. Unfold wings fully until main cylinder pins centre in their slots.
3. Lower tail and modules fully

When unfolding the wings, oil travels directly to the right-hand outer wing cylinders until they are fully extended. Oil then opens S3 and flows to the left-hand outer wing cylinders. When these are fully extended, oil pressure opens S4 and flows to the center cylinders pushing the extended wings to the ground. There is an over-center valve, L1, that protects the main wings from falling and controls their decent.



RIGHT WING WON'T RISE FROM FOLDED POSITION

If the pressure required to raise the right wing is greater than tractor pressure, then oil will not flow. This may occur if chain is full of mud or other matter increasing the weight of the chain. It may also occur on tractors with lower than original hydraulic oil pressure.

If the pressure setting of S3 is too low, it can open before lifting the top wing. Oil will then try to raise the second wing, which is trapped and cannot move. The main cylinders will try to force the wings apart.

Disc chain may be caught on one of the saddles or supports, especially on the tail, preventing the wing from lifting. Usually, you will see the top wing raise a little then stop if this is the case.

Oil may bypass a cylinder piston seal if the seal or piston have failed. You will hear oil flowing in one cylinder and that cylinder should warm up compared to the remaining cylinders.

Check-valves C4 or C5 may be held open by contamination allowing oil to flow to left wing or main cylinders.

Solution

Clean chains of mud and debris.

Check the disc chain for areas it might be caught and make adjustments to support brackets or folding procedure.

Increase the pressure setting on S3 by 1/2 turn clockwise. (Repeat if required). Remove Check-valve C4 or C5 and inspect.

If oil is flowing through the manifold but no movement is occurring, then it is possible that a piston seal has failed. Sequentially isolate cylinders until culprit is identified. (Fold wings to transport position before removing cylinders, DEATH or INJURY could result.)

Check that tractor hydraulic oil pressure is adequate (2200psi / 151Bar).

CENTER CYLINDERS EXTEND BEFORE OUTER WINGS ARE BOTH STRAIGHT (VERTICAL)

If the pressure required to raise the right wing is greater than that set by S3 then oil will flow past S3 to the left wing. As the right wing rests on top of the left wing and neither can move then oil is also forced past S4 to the main wing cylinders causing them to extend while the outer wings are still folded. As the main wings unfold and the weight is transferred from the outer wings then the oil will flow to the outer wing cylinders allowing the wings to straighten. Do not allow this to continue as the cylinder pins will shear and the wings will fall uncontrolled.

The same symptom will occur if check valve C4 is held open by contamination.

As above, mud or debris in the chain will change the load and operating pressure required to lift the outer wings.

Solution

If chains are clean, then increase the pressure setting on S3. (right wing will raise) Increase pressure setting on S4 (left wing will raise)

Remove and inspect Check valve C4. Clear any foreign material from around ball & seat area.



RIGHT WING RISES BUT LEFT WING WON'T RISE

If the pressure required to raise the left wing is greater than tractor pressure, then oil will not flow. This may occur if chain is full of mud or other matter increasing the weight of the chain. It may also occur on tractors with lower than original hydraulic oil pressure. Left wing is longer than right wing and may require more pressure to lift.

If the pressure setting of S3 is too high, then oil will stall and left wing will not raise.

Disc chain may be caught on one of the saddles or supports, especially on the rear "M" bracket mounts, preventing the wing from lifting.

Oil may bypass a cylinder piston seal if the seal or piston have failed. You will hear oil flowing in one cylinder and that cylinder should warm up compared to the remaining cylinders.

A check-valve may be stuck open allowing oil to bypass.

Solution

Clean chains of mud and debris.

Check the disc chain for areas it might be caught and make adjustments to support brackets or folding procedure.

Decrease the pressure setting on S3 by 1/2 turn clockwise. (Repeat if required) Remove and inspect check-valve C4. Clear any contamination and reinstall.

If oil is flowing through the manifold but no movement is occurring, then it is possible that a piston seal has failed. Sequentially isolate cylinders until culprit is identified. (Fold wings to transport position before removing cylinders, DEATH or INJURY could result)

Check that tractor hydraulic oil pressure is adequate (2200psi / 151Bar).

BOTH WINGS STAND VERTICAL THEN STOP

Once the outer wings have stood vertical oil pressure opens S4 and allows flow to the main wing cylinders. An overcentre valve, L1 prevents the wings from falling and controls their descent to working position.

Solution

Lower pressure setting on S4, screw centre counterclockwise 1/2 turn, check, repeat if needed.

L1 overcentre valve may be set too high, preventing return oil flowing to tank. Reduce pressure setting on L1 by turning CLOCKWISE 1 turn.

Check that hydraulic flow on the tractor is not set to very low or off. Check tractor hydraulic pressure (should exceed 2200 psi -151 Bar).

Call service technician. Test for oil flow. If flow is present isolate cylinders one at a time to ensure integrity of cylinder piston seal. (Fold wings to transport position before removing cylinders, DEATH or INJURY could result.)



NO MOVEMENT AT ALL

Solution

See first point. Check and if necessary clean chains of mud or debris. Check that hose tips are correctly engaged in tractor breakaway sockets. Check that any ball valves or electronic transport locks are open on the tractor. Check that hydraulic flow on the tractor is not set to very low or off.

Check tractor hydraulic pressure (should exceed 2200 psi -151 Bar).

Call service technician. Test for oil flow. If flow is present isolate cylinders one at a time to ensure integrity of cylinder piston seal. If a V12 manifold, check Appendix A for troubleshooting.

SEQUENCE WAS WORKING BUT HAS BECOME ERRATIC

The sequence valve manifold has an oil flow capacity of 8 gallons (US) per minute (30Lpm).

At this flow the sequence cartridges are able to cope with the flow of oil and operate at their correct settings. If the flow rate is set too high, pressure in the manifold builds up and may unseat thesequence valves prematurely or in an unpredictable manner.

Solution

Set tractor hydraulic remote oil flows to slow (20%). Engage tractor hydraulic lever slowly.

Reduce flow by screwing flow control valve E counterclockwise 2 turns.



Folding

The fold sequence is as follows.

1. Raise tail and modules
2. Raise wings until fully folded
3. Raise front A-Frame to transport height.

During folding, oil travels directly to the main wing cylinders. When these are all closed oil then opens S1 allowing oil to flow to the left outer wing cylinders. When these cylinders close oil pressure opens S2 to fold the right outer wing.

NO MOVEMENT AT ALL

The main cylinders are the first to receive oil from tractor and should lift the wings. Failure to operate as expected could indicate excess mud in the discs. If the tail has not been raised, it is possible that the wings will not lift up as the chain tension prevents them from rising.

Solution

Clean mud from the discs.

Raise the tail section fully prior to folding the wings.

BOTH MAIN WINGS STAND VERTICAL THEN LEFT WING WON'T FOLD.

Oil flows straight from tractor to the main cylinders. Once raised oil must then force S1 open to allow flow to the left outer wing. If S1 is set too high, then oil flow will stall and the left outer wing will not fold.

Over centre valve L4 is used to hold the left wing straight during operation. If L4 is set at too high a pressure the left wing will not fold. L4 is a pilot operated valve and requires correct system pressure to function.

A pressure control valve, PL (7.2) is used to protect the frame in the event that wings collide when folding. If the pressure setting on PL is too low, then there will be insufficient pilot pressure to operate L4 valve. Before adjusting L4 ensure that PL is set correctly.

Solution

Reduce the pressure setting on S1 by screwing counterclockwise 1/2 turn. (Repeat as required). Increase pressure setting on PL (7.2) by screwing clockwise 2 turns.

Reduce pressure setting on L4 by screwing CLOCKWISE 1 turn.



LEFT HAND OUTER WING FOLDS BEFORE BOTH INNER WINGS ARE VERTICAL

If the pressure required to raise the wings to vertical is greater than the pressure setting on S1 then oil will pass S1 and cause the left hand outer wing cylinders to retract. This may occur if there is excessive load such as mud or debris or on occasions where the chains may have become blocked and buried.

The same symptom can be seen if check-valve C3 is held open by contamination.

Solution

Check and clean if necessary any mud or debris from chains. Do not attempt to fold the machine if the chains are buried during a blockage. Clear away the soil from the chains first.

If the chains are clean but problem persists it may be necessary to adjust S1. Increase the pressure setting by screwing clockwise 1/2 turn.

Remove and clean C3 Check-valve.

RIGHT HAND OUTER WING FOLDS BEFORE BOTH INNER WINGS ARE VERTICAL

In the normal folding process, the Left wing must fold before the Right wing. Even if both S1 and S2 have pressure settings that are too low, then both wings will move together. For the Right outer wing to move first then Check-valve C1 must be open.

Solution

Remove and clean C1 check-valve.

MAIN WINGS FOLD, LEFT OUTER WING FOLDS THEN RIGHT OUTER WING STANDS VERTICAL.

Oil is forced to the Left outer wing cylinders which cause the left wing to fold down. Once these cylinders are closed oil pressure increases and opens S2 allowing oil to flow to the right hand outer wing cylinders. If S2 is set too high, the oil flow can stall after left outer wing is folded.

Over centre valve L3 is used to hold the right wing straight during operation. If pressure setting on L3 is too high the left wing will not fold. L3 is a pilot operated valve and requires correct system pressure to function.

A pressure control valve, PR is used to protect the frame in the event that wings collide when folding. If the pressure setting on PR is too low, then there will be insufficient pilot pressure to operate L3 valve. Before adjusting L3 ensure that PR is set correctly.

Solution

Reduce the pressure setting on S2 by screwing counterclockwise 1/2 turn. (Repeat as required). Increase pressure setting on PR by screwing anticlockwise 2 turns.

Reduce pressure setting on L3 by screwing CLOCKWISE 1 turn.



OUTER WINGS COLLIDE WHEN FOLDING.

If you witness the two outer wings coming together when folding, you must immediately stop and reverse the operation. Unfold the wings to vertical then recommence slowly. The individual wings should fold in sequence. If they both continue to fold together then oil must be passing S2 prematurely. For this to happen S2 has pressure set too low.

Solution

Increase the pressure setting on S2 by screwing clockwise 1/2 turn. (Repeat as required).

LEFT OUTER WING STANDS VERTICAL AND RIGHT OUTER WING FOLDS OVER

The main wings stand vertical then the left wing does not move but the right hand outer wing folds over then all movement stops. This can occur when the L4 overcentre valve that holds the wing straight during operation in the field, will not release and allow the wing to fold. L4 could be contaminated but would usually stick open. L4 could have failed but this is rare. PL may be set at a pressure too low to activate the pilot release on L4.

Solution

Increase the pressure setting on PL by screwing it clockwise 2 turns. Decrease the pressure setting on L4 by screwing it COUNTERCLOCKWISE 1/2 turn.

SEQUENCE WAS WORKING FINE BUT HAS BECOME ERRATIC

The sequence valve manifold has an oil flow capacity of 8 gallons (US) per minute. (30Lpm).

At this flow the sequence cartridges are able to cope with the flow of oil and operate at their correct settings. If the flow rate is set too high, pressure in the manifold builds up and may unseat these sequence valves prematurely or in an unpredictable manner.

Occasionally foreign material may lodge in one of the check valves. This will allow oil to flow in a seemingly illogical manner. Symptoms suggest valve adjustments however the logical adjustments have no effect.

Solution

Set tractor hydraulic remote oil flows to slow (20%). Engage tractor hydraulic lever slowly.

Reduce flow by screwing flow control valve R counterclockwise 2 turns.



NO MOVEMENT AT ALL

Solution

Check that hose tips are correctly engaged in tractor breakaway sockets.

Check that any shut off valves or electronic transport locks are open on the tractor. Check that hydraulic flow on the tractor is not set to very low or off.

Check tractor hydraulic pressure (should exceed 2200psi - 151 Bar).

Call service technician. Test for oil flow. If flow is present isolate cylinders one at a time to ensure integrity of cylinder piston seal. If a V12 manifold, check Appendix A for troubleshooting.

Working

WINGS “SAG” IN THE MIDDLE WHEN WORKING

Both sets of wings are locked straight in working position by the L4 and L3 over center valves. If the pressure setting on these valves is too low the wings may not be effectively locked.

Solution

Left wing sagging, increase the pressure setting on L4 by screwing it COUNTERCLOCKWISE 1/2 turn.

Right wing sagging, increase the pressure setting on L3 by screwing it COUNTERCLOCKWISE 1/2 turn.



Appendix A: Troubleshooting Guide for V12 Manifold

Tools and supplies required:

- 1/2 box end wrench
- 9/16 box end wrench
- 5/8 box end wrench
- 3/4 box end wrench
- 1 1/4 deep socket – Thin-walled socket works best
- 1 3/4 socket – Thin-walled socket works best
- SAE Allen wrenches
- Brake cleaner
- Paper towels
- Disposable gloves

Checklist for establishing hydraulic flow to the valve block.

Step 1 Adjusting the flow control valve

- Loosen jam nut.
- Increase flow by turning the **E** and **R** valves **CCW** (counterclockwise) until they stop.
- When valve stops **do not** force it further.
- Try **folding** or **unfolding** machine.
- Expected folding time should be no less than **three minutes**. It may be necessary to adjust flow control (clockwise) so that the disc chains are not swinging as they rest into the L brackets.

Step 2 Inspect the flow control valve

- If the machine will not **fold** or **unfold**, the flow control valves may be faulty and need to be removed or inspected.
- **Float** tractor hydraulics for this circuit.
- Turn tractor **off**.
- Clean area of **all** dust, mud and debris from the valve block and surrounding area.
- **DO NOT CONTAMINATE VALVE BLOCK.**
- Remove non-functioning valve.
- Inspect **port** that valve was removed from for **rubber pieces** or **other debris**.
- Inspect the **end** of the valve for **rubber pieces** or **debris**.

You should see a **shiny metal bottom** if you look down into the valve cavity.

- **NOTE**, if debris is found, **move** to **step 3**.
- If debris is **not** found, remove the other **flow control valve**, swap it with the valve that is **not functioning**.
- Tighten valve back into port.
- Try folding or unfolding machine.



- If flow control valve has malfunctioned, the problem will follow the valve. If the machine was not folding, now it will fold but will not unfold. If the machine was not unfolding, now it will unfold but will not fold.
- **Answer**, order a new **flow control valve** to replace the **failed valve**.
- **Answer**, to fold and unfold the machine until the replacement valve arrives, repeat the valve **SWAPPING PROCESS** but do not **contaminate** the **valve block**.

Step 3 removal of debris

If rubber pieces or debris are found in the **flow control valves** or **ports**, the filter needs to be **cleaned** and **inspected**.

- Remove filter from the side of the block corresponding to the non-functional flow control valve.
- Filter can be found under the large 1 ¾ cap and is under spring load.
- After removal of the nut, there will be a spring which is followed by the filter (**compressed brass BB's**) followed by an internal spring.
- Do not contaminate the **springs** or **filters**.
- Inspect filter port in block and clean.
- Inspect rubber washer that the filter is seated on internally in port. **NOTE**, this is where rubber debris is likely from.
- Remove all rubber and debris.
- Remove the rubber washer from the other flow control cartridge cavity. It will be located between the filter and the block. It is likely that the washer on the functional side is about to fail as well (if working on **E** then remove **R** if working on **R** remove from **E**)
- **NOTE**, the oil flows from the filter to the flow control at a 90-degree angle. Shine a flashlight in the filter port to see it from the other side.

Step 4. If folding out of sequence was the symptom then a small adjustment of the “S” valves should resolve the issue. Turn the relevant valve as described above, clockwise until it gently bottoms out. Then turn it counter-clockwise as per the table below. If it is possible to have someone activate the SCV, do so while making the relevant adjustment. Slowly turn the valve counter-clockwise until oil is heard to flow, continue until the relevant wing section moves then continue perhaps 1/8 turn more for optimum oil flow.

The settings listed in the table below are starting with the valve screwed all the way clockwise until it bottoms out. Once this is achieved, then screw the valve counter-clockwise the number of revolutions listed below.



Contact Details

IF THESE ADJUSTMENTS DO NOT SOLVE THE PROBLEM

Contact your service agent for assistance. There may be a fault with one of the cartridges.

The valve manifolds are tested at factory and again prior to shipping. The assembling agent will also have ensured the correct operation prior to delivery. Very rarely, but occasionally valves do fail. The usual cause is ingress of contaminant.

You may also contact Kelly Tillage for technical advice and assistance.



Notes





