

# 40

Kelly<sup>★</sup>

## Tillage System Model 40 Assembly and Parts Manual

Revision K - July 2019

Serial Number:

Kelly Engineering  
PO Box 100  
Booleroo Centre  
South Australia 5482  
P +61 8 8667 2253  
F +61 8 8667 2250  
W [kellyengineering.com.au](http://kellyengineering.com.au)

# Thank you for choosing a Kelly Engineering product

We trust that you find the following manual clear and easy to follow. If you should require additional customer support or assistance, please do not hesitate to contact us.

Spare parts can be purchased, as required, through your local dealer or by contacting Kelly Engineering Australia or in the United States, Hood & Company.

Kelly Engineering welcomes feedback. Should you have any difficulties that you wish to raise, suggestions for improvement or modifications that you feel would enhance our products we look forward to hearing from you.

## **Australia**

### **Kelly Engineering**

**PO Box 100**

**Boomeroo Centre SA 5482**

**Phone:** + 61 8 8667 2253

**Fax:** + 61 8 8667 2250

**Email:** sales@kellyengineering.com.au

**Spare Parts:** parts@kellyengineering.com.au

**Website:** www.kellyengineering.com.au

## **United States**

### **Kelly Engineering**

Website: www.kellyharrows.com

## **Spare Parts**

### **Hood & Company Inc**

**Springfield MO**

**Phone:** 417 865 2100

**Fax:** 417 865 2105

**Email:** hoodco@hoodco.com

# Contents

|                                       | Page no    |
|---------------------------------------|------------|
| <b>Section 1: Unpacking</b>           | <b>5</b>   |
| <b>Section 2: Parts</b>               | <b>8</b>   |
| <b>Section 3: Decal Placement</b>     | <b>119</b> |
| <b>Section 4: Chain Assembly</b>      | <b>142</b> |
| <b>Section 5: Diagrams and Charts</b> | <b>152</b> |
| <b>Section 6: Operation</b>           | <b>157</b> |



This symbol indicates which bag the relevant fasteners are in



This symbol indicates which bag the relevant hydraulics are in

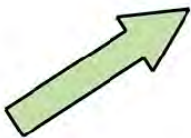

This symbol indicates which way the machine is travelling

## Bolt Torque Settings

| Bolt Type        | Wheel nut |     |      |       | U Bolt |     |     | Grade 8.8 Bolt |     |     |     |     | Grade 10.9 Bolt |     | Grade 8 Bolt |
|------------------|-----------|-----|------|-------|--------|-----|-----|----------------|-----|-----|-----|-----|-----------------|-----|--------------|
| <b>Bolt Size</b> | M18       | M20 | 1/2" | 9/16" | M10    | M12 | M16 | M10            | M12 | M16 | M20 | M24 | M20             | M24 | 1" UNF       |
| <b>Ft lb</b>     | 255       | 265 | 90   | 100   | 22     | 36  | 55  | 32             | 48  | 140 | 190 | 270 | 300             | 350 | 849          |
| <b>Nm</b>        | 345       | 360 | 125  | 140   | 30     | 50  | 75  | 44             | 65  | 190 | 260 | 370 | 406             | 475 | 1151         |

[1] When fitting a wheel & tire to a hub, tighten the wheel nuts in a star pattern to the correct tension. To achieve this choose a wheel nut & tighten, then proceed to the opposite side of the hub to the next wheel nut & tighten & so on until all wheel nuts are tight. Then repeat the procedure to check that all nuts are tight. Do not use impact tools to tighten wheel nuts. For a guide to the correct tension of the wheel nuts please use the appropriate tension for your size wheel nuts from the Bolt Torque Settings table.

Torque values are for dry threads and surfaces however it is permissible to apply a small amount of anti corrosive oil to the threads.

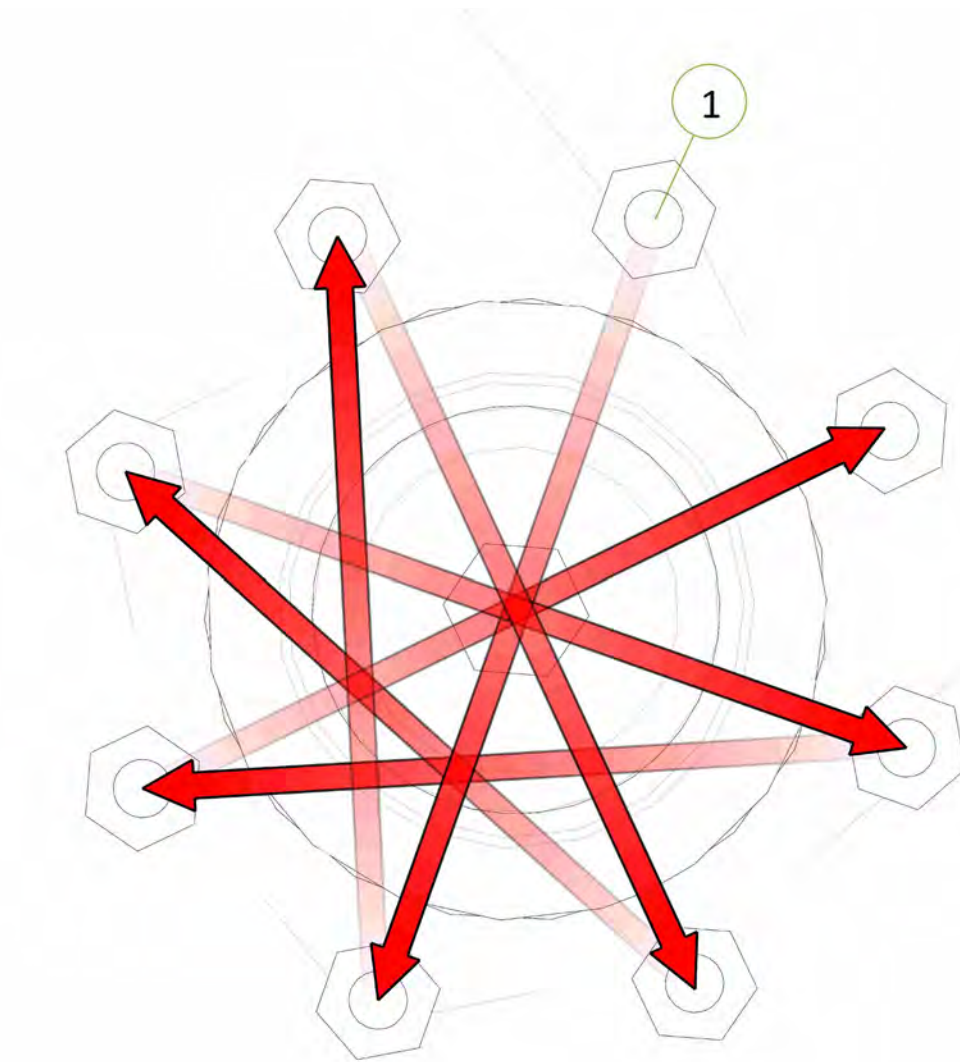



# Section 1

## Unpacking

# Unpacking

*We recommend that a crane and forklift truck be available for unloading and assembly*



- Before opening shipping container inspect exterior for any damage. Remove seal and open container doors.



## CAUTION

**Take care when opening doors as load may have shifted or restraints may have broken.**

- Remove boxes from doorway of container one at a time using a forklift truck. Each box weighs approximately 2600 lbs (1200kg)
- Check strapping on each bundle before attempting to remove
- Attach chains to the packing frame using shackles and using suitable equipment (eg. fork-lift or tractor) drag framework bundles out of container. To move bundles away from front of container lift from side with forklift. Do not lift under angle iron frame, lift only under centre frame. Each bundle weighs approximately 7000 lb (3200 kg).

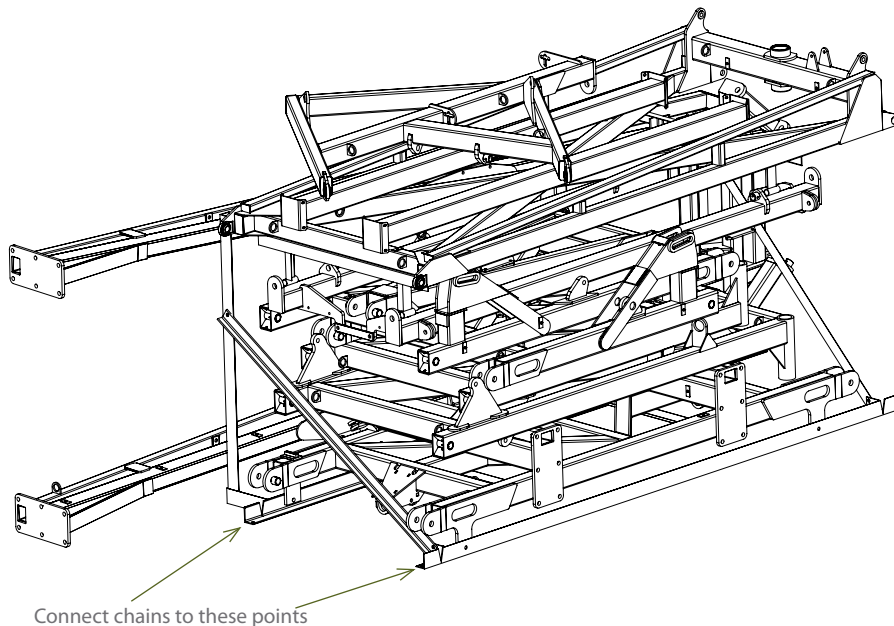

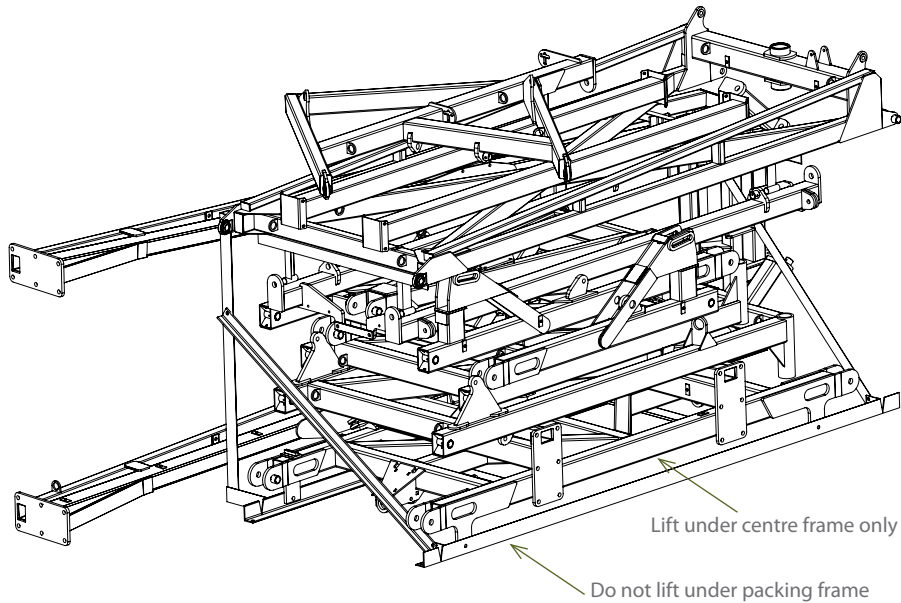

### CAUTION

Before cutting straps attach slings or chains and take the weight of the frames to avoid them slipping or falling and causing injury.



### CAUTION

Wear eye and hand protection when cutting straps. Sharp edges are exposed as straps separate and may cause injury.



### CAUTION

To avoid falling or moving components, before cutting straps attach slings or chains to individual pieces and only cut the straps holding the piece to be lifted.

- Remove boxes from rear of container one at a time using a forklift truck. Each box weighs approximately 2600 lbs (1200 kg)
- Cut straps holding bundles and separate parts and place in assembly area
- Identify parts for each machine by serial no. or description and separate. Open parts box and check that all parts are accounted for against checklist
- Once all parts have been identified machines are ready for assembly
- Read assembly instructions before proceeding.

# Section 2

Parts

| Item No. | Description                                    | Number          | Qty |
|----------|--|-----------------|-----|
| 1        | 40' Centre Frame                               | 0840-01         | 1   |
| 2        | 2.75"R 6 Tonne 8 on 8" PCD Hub & Stub Complete | 0733-SH27596880 | 2   |
| 3        | M20 x 170 grade 8.8 ZP Bolt                    | 0211-20170      | 2   |
| 4        | Nyloc Nut M20                                  | 0221-NYL20      | 2   |

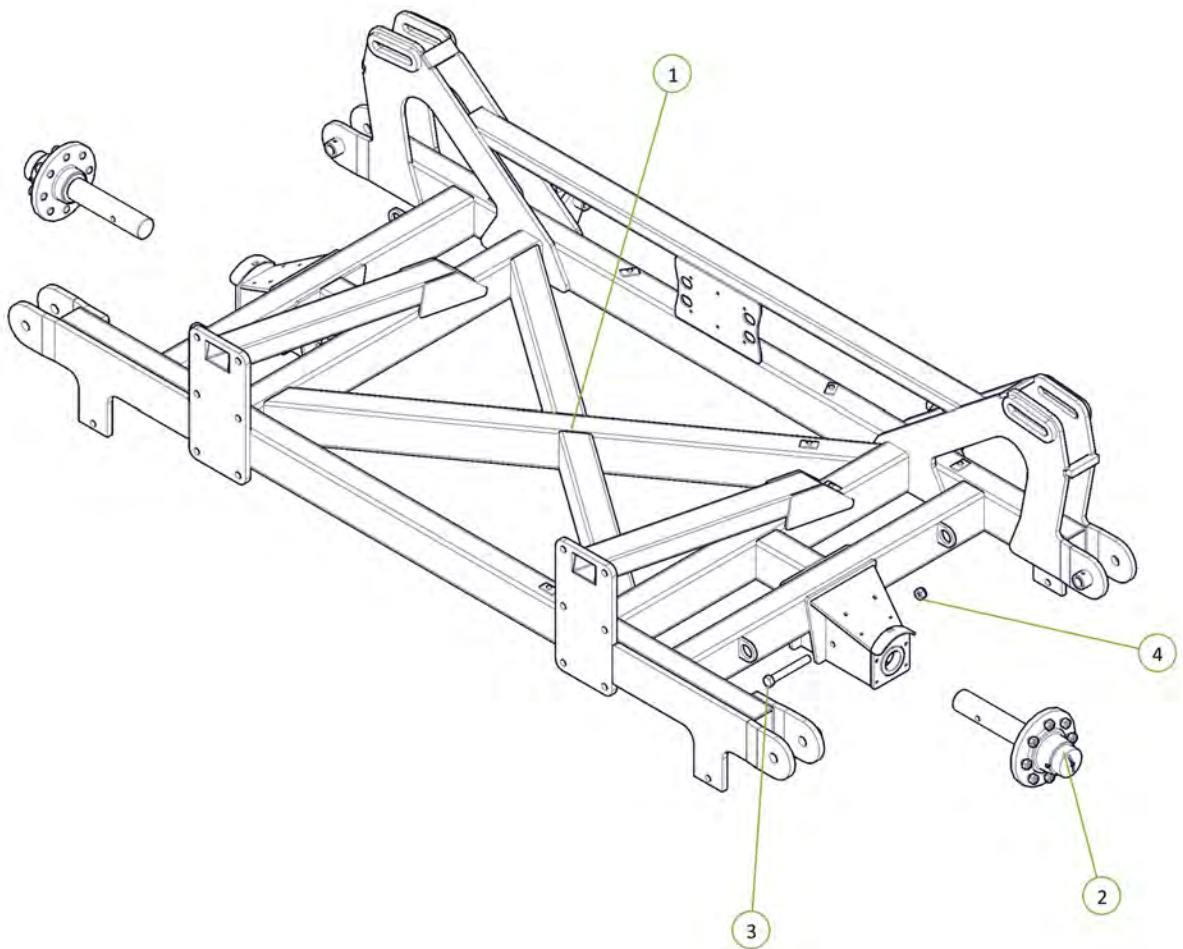

| Item No. | Description                   | Number         | Qty |
|----------|-------------------------------|----------------|-----|
| 1        | 40' LH Inner Wing Frame       | 0840-05        | 1   |
| 2        | PCH Wing Pivot Pin            | 0801-10-08-235 | 2   |
| 3        | 35 ID x 50mm DX Bush          | 0113-MB 3550DX | 4   |
| 4        | Grease Nipple 1/8" BSP 45 Deg | 0181-GN1-845   | 2   |
| 5        | Cotter Pin M13 x 63           | 0261-PINC1363  | 2   |
| 6        | M12 x 65 grade 8.8 ZP Bolt    | 0211-1265      | 2   |
| 7        | Nyloc Nut M12                 | 0221-NYL12     | 2   |

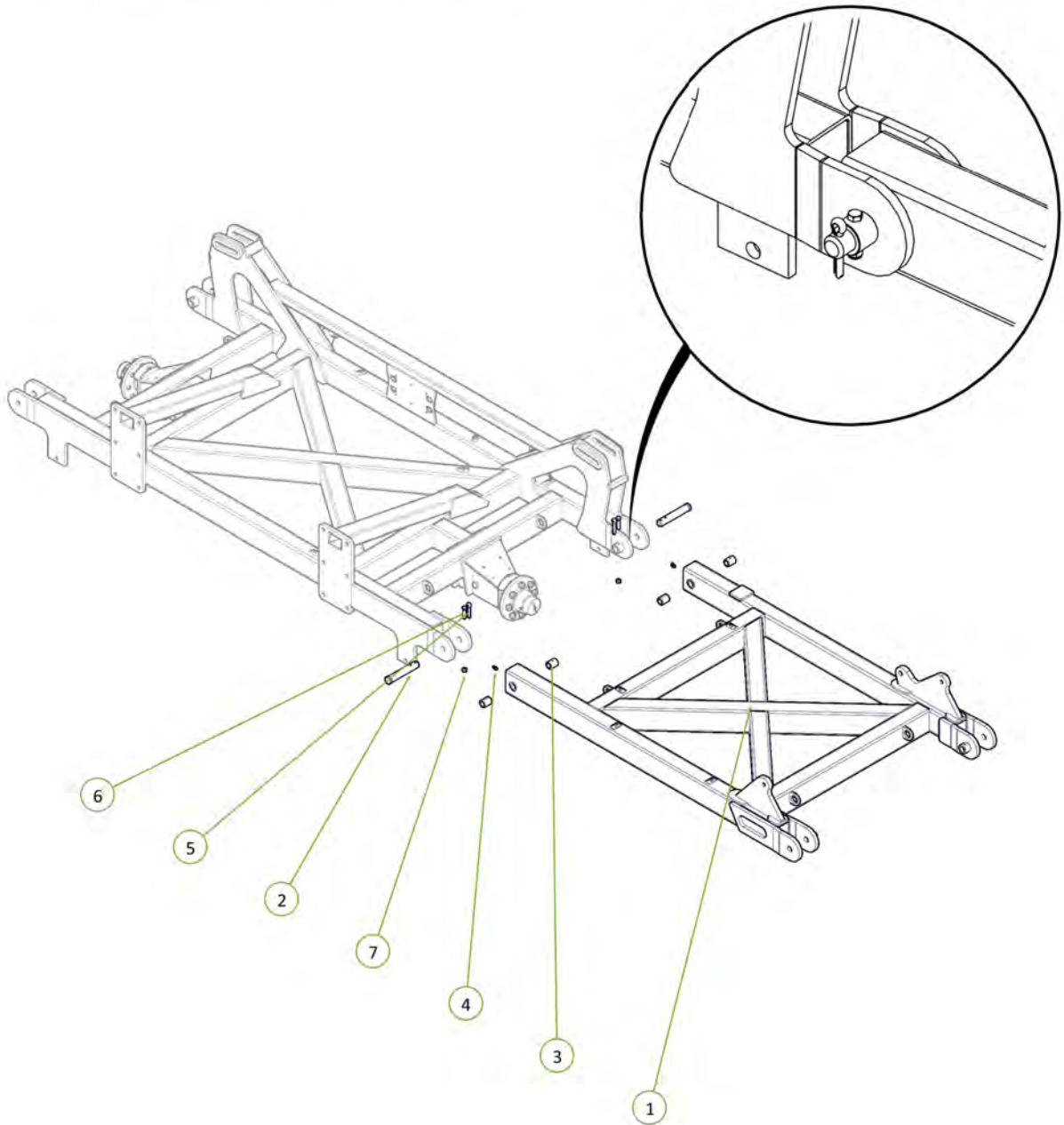
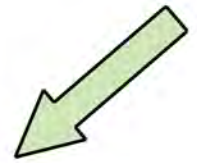



| Item No. | Description                   | Number         | Qty |
|----------|-------------------------------|----------------|-----|
| 1        | 40' LH Outer Wing Frame       | 0840-07        | 1   |
| 2        | 35 ID x 50mm DX Bush          | 0113-MB 3550DX | 4   |
| 3        | Grease Nipple 1/8" BSP 45 Deg | 0181-GN1-845   | 2   |
| 4        | PCH Wing Pivot Pin            | 0801-10-08-235 | 2   |
| 5        | Cotter Pin M13 x 63           | 0261-PINC1363  | 2   |
| 6        | Nyloc Nut M12                 | 0221-NYL12     | 2   |
| 7        | M12 x 65 grade 8.8 ZP Bolt    | 0211-1265      | 2   |

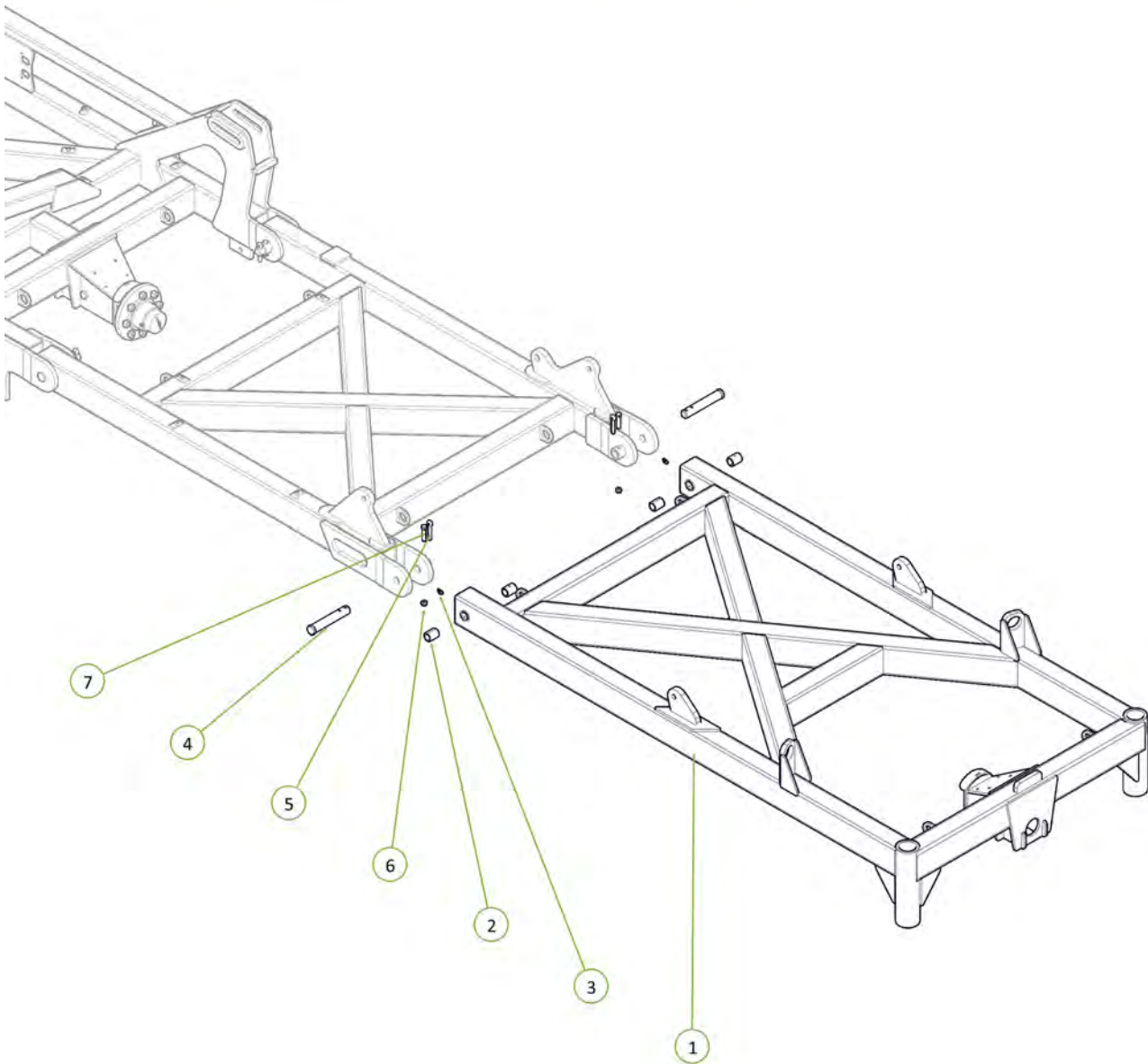
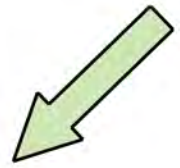



| Item No. | Description                   | Number         | Qty |
|----------|-------------------------------|----------------|-----|
| 1        | 40' RH Inner Wing Frame       | 0840-04        | 1   |
| 2        | 35 ID x 50mm DX Bush          | 0113-MB 3550DX | 4   |
| 3        | Grease Nipple 1/8" BSP 45 Deg | 0181-GN1-845   | 2   |
| 4        | PCH Wing Pivot Pin            | 0801-10-08-235 | 2   |
| 5        | Cotter Pin M13 x 63           | 0261-PINC1363  | 2   |
| 6        | M12 x 65 grade 8.8 ZP Bolt    | 0211-1265      | 2   |
| 7        | Nyloc Nut M12                 | 0221-NYL12     | 2   |

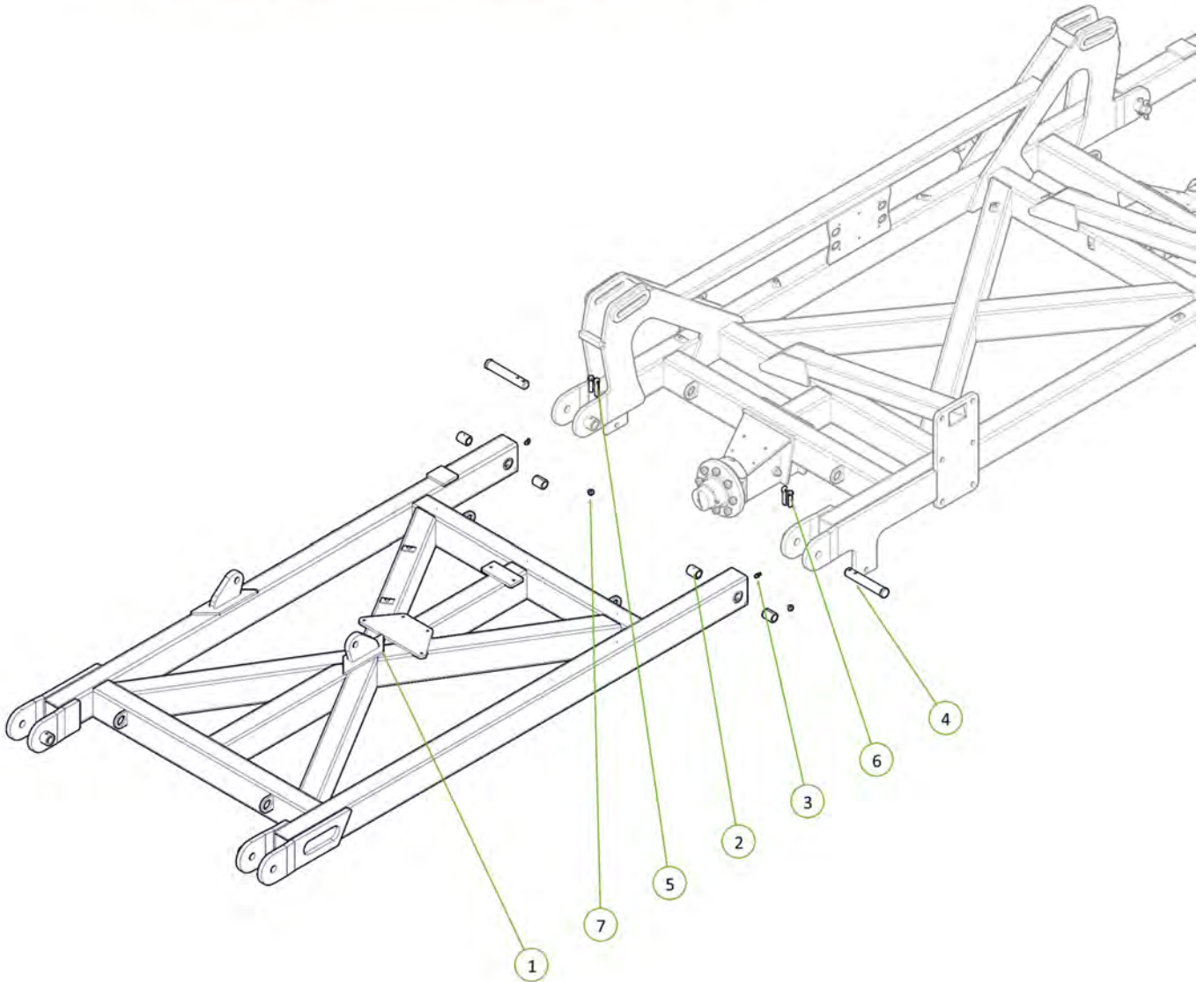
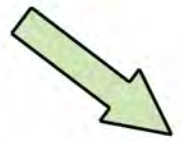

| Item No. | Description                   | Number         | Qty |
|----------|-------------------------------|----------------|-----|
| 1        | 40' RH Outer Wing Frame       | 0840-06        | 1   |
| 2        | 35 ID x 50mm DX Bush          | 0113-MB 3550DX | 4   |
| 3        | Grease Nipple 1/8" BSP 45 Deg | 0181-GN1-845   | 2   |
| 4        | PCH Wing Pivot Pin            | 0801-10-08-235 | 2   |
| 5        | Cotter Pin M13 x 63           | 0261-PINC1363  | 2   |
| 6        | M12 x 65 grade 8.8 ZP Bolt    | 0211-1265      | 2   |
| 7        | Nyloc Nut M12                 | 0221-NYL12     | 2   |

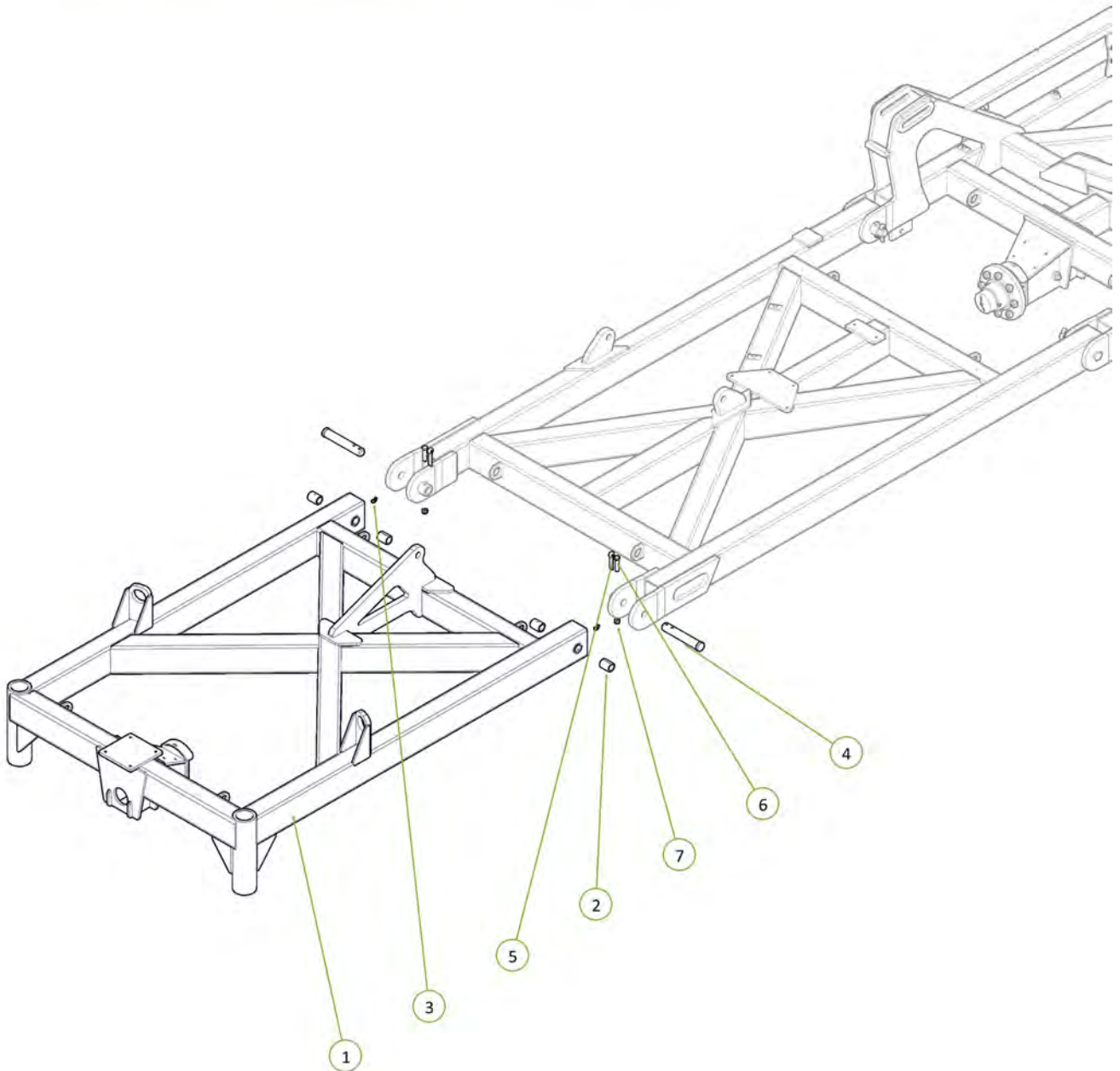
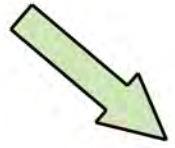

| Item No. | Description                | Number     | Qty |
|----------|----------------------------|------------|-----|
| 1        | 40' Inner Wing Post        | 0840-04P   | 1   |
| 2        | M12 x 50 grade 8.8 ZP Bolt | 0211-1250  | 6   |
| 3        | Nyloc Nut M12              | 0221-NYL12 | 6   |

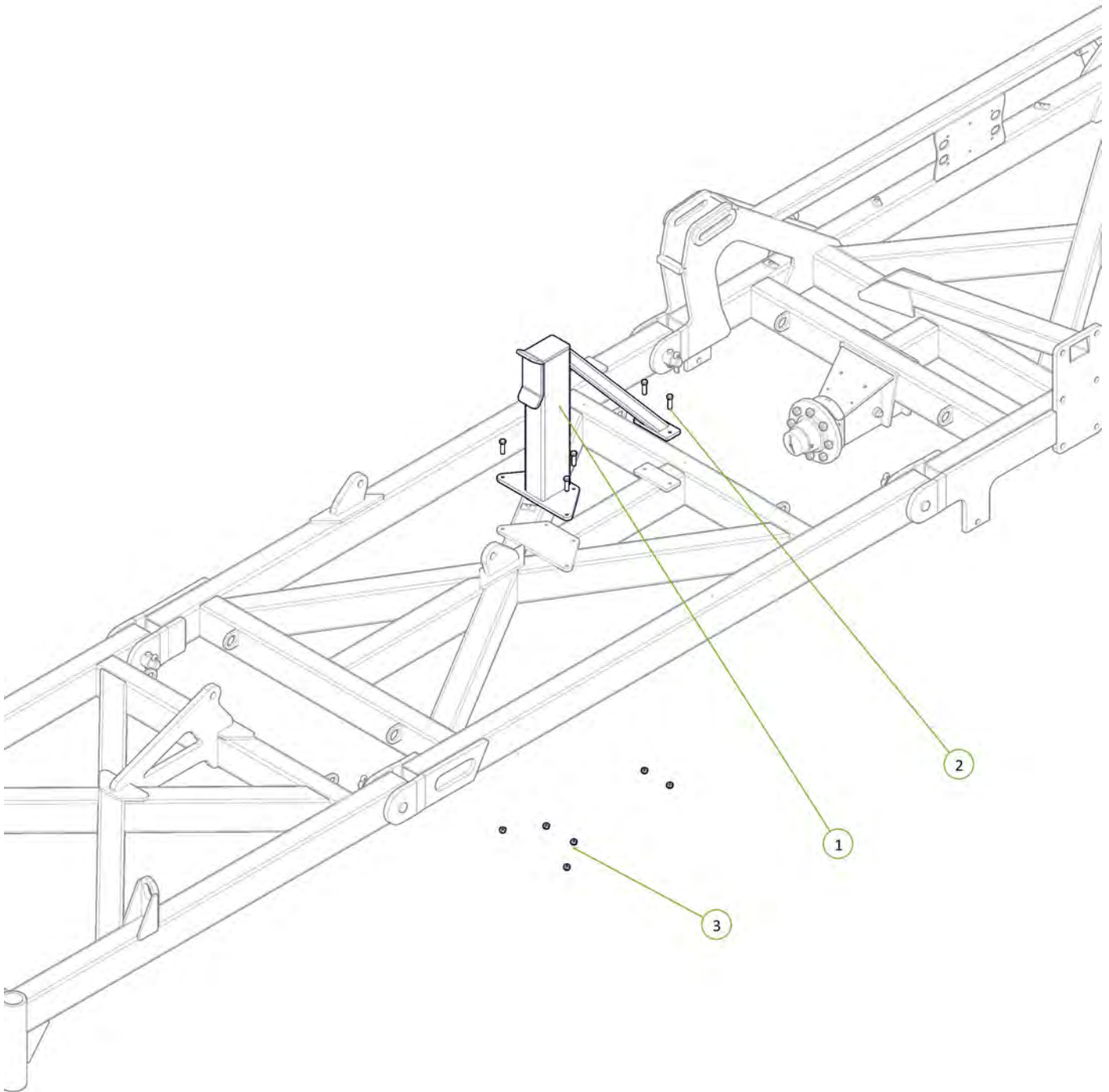
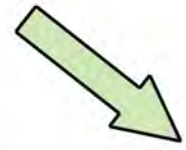

| Item No. | Description                | Number     | Qty |
|----------|----------------------------|------------|-----|
| 1        | 40' Outer Wing Post        | 0840-06P   | 1   |
| 2        | M12 x 40 grade 8.8 ZP Bolt | 0211-1240  | 4   |
| 3        | Nyloc Nut M12              | 0221-NYL12 | 4   |

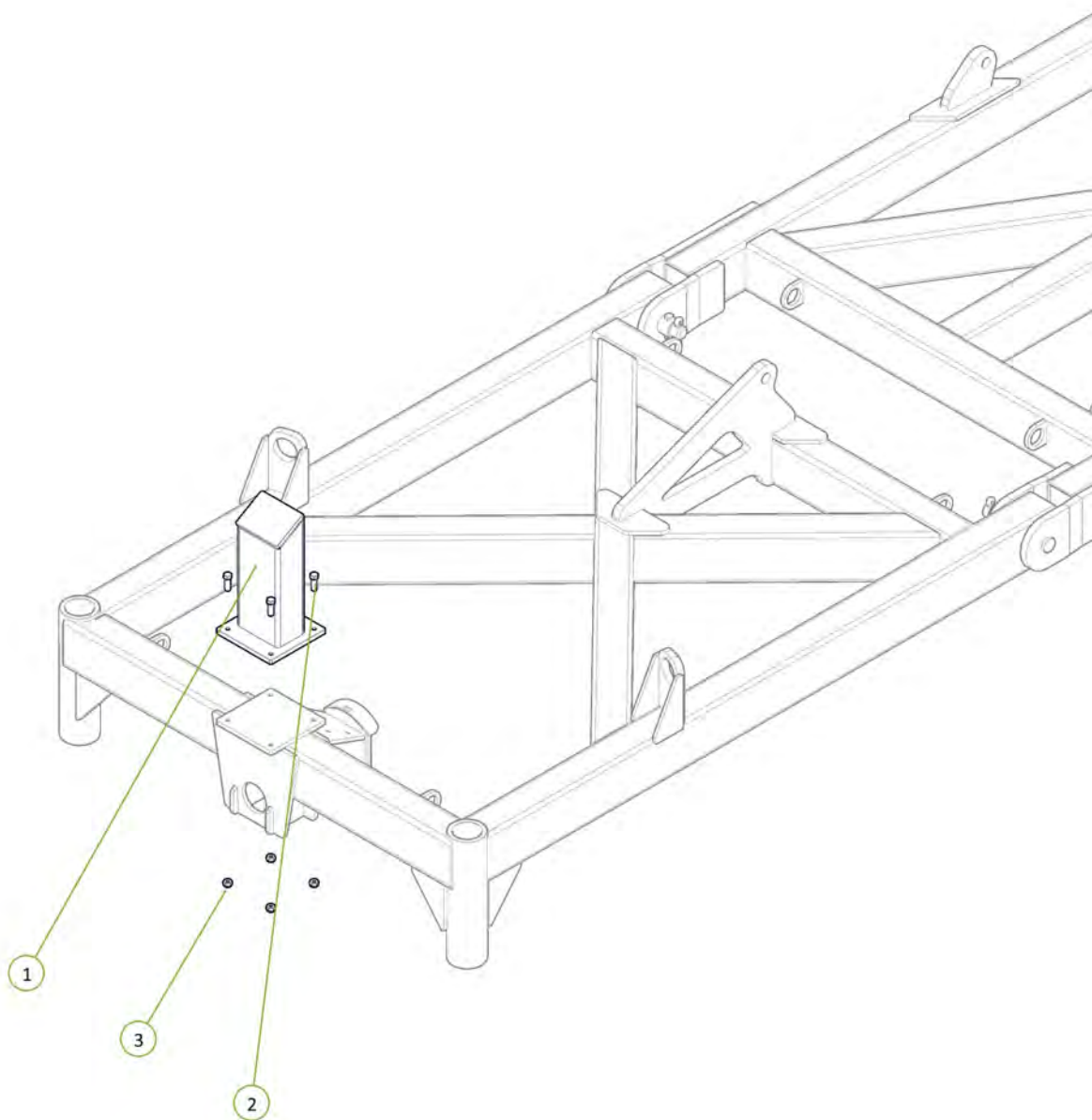
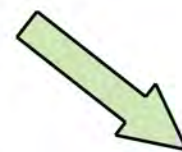



| Item No. | Description                                | Number      | Qty |
|----------|--|-------------|-----|
| 1        | Dual Circuit 3 Stage Sequence Manifold V12 | 0802-691033 | 1   |
| 2        | M10 x 25 grade 8.8 ZP Bolt                 | 0211-1025   | 6   |
| 3        | Washer Flat M10                            | 0231-F10    | 6   |
| 4        | Washer Spring M10                          | 0231-S10    | 6   |

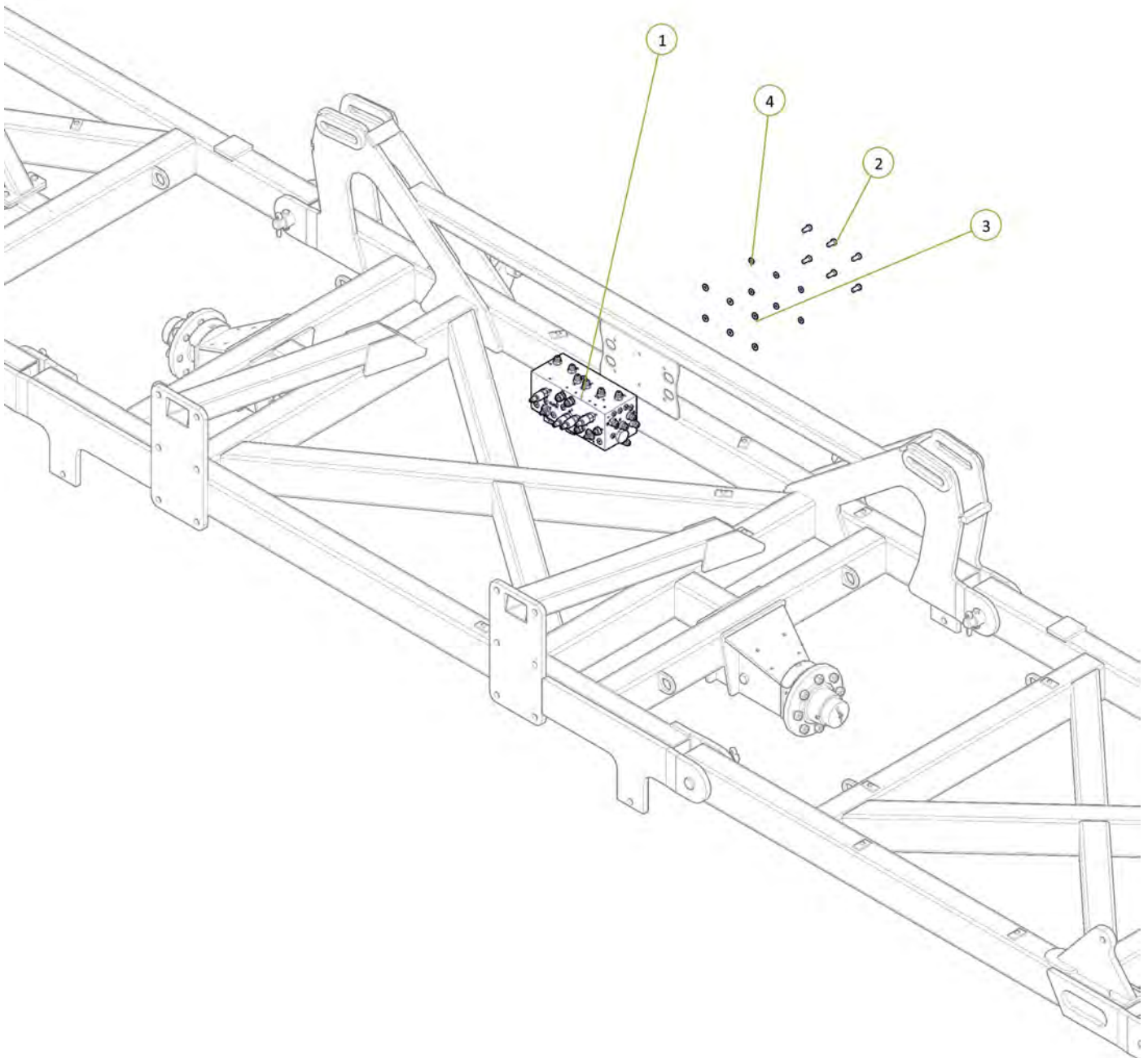

| Item No. | Description  | Number     | Qty |
|----------|--|------------|-----|
| 1        | 5" Bore 30" Stroke 3 1/8" S/Tube 2" Rod Hydraulic Cylinder | 0311-530ST | 1   |

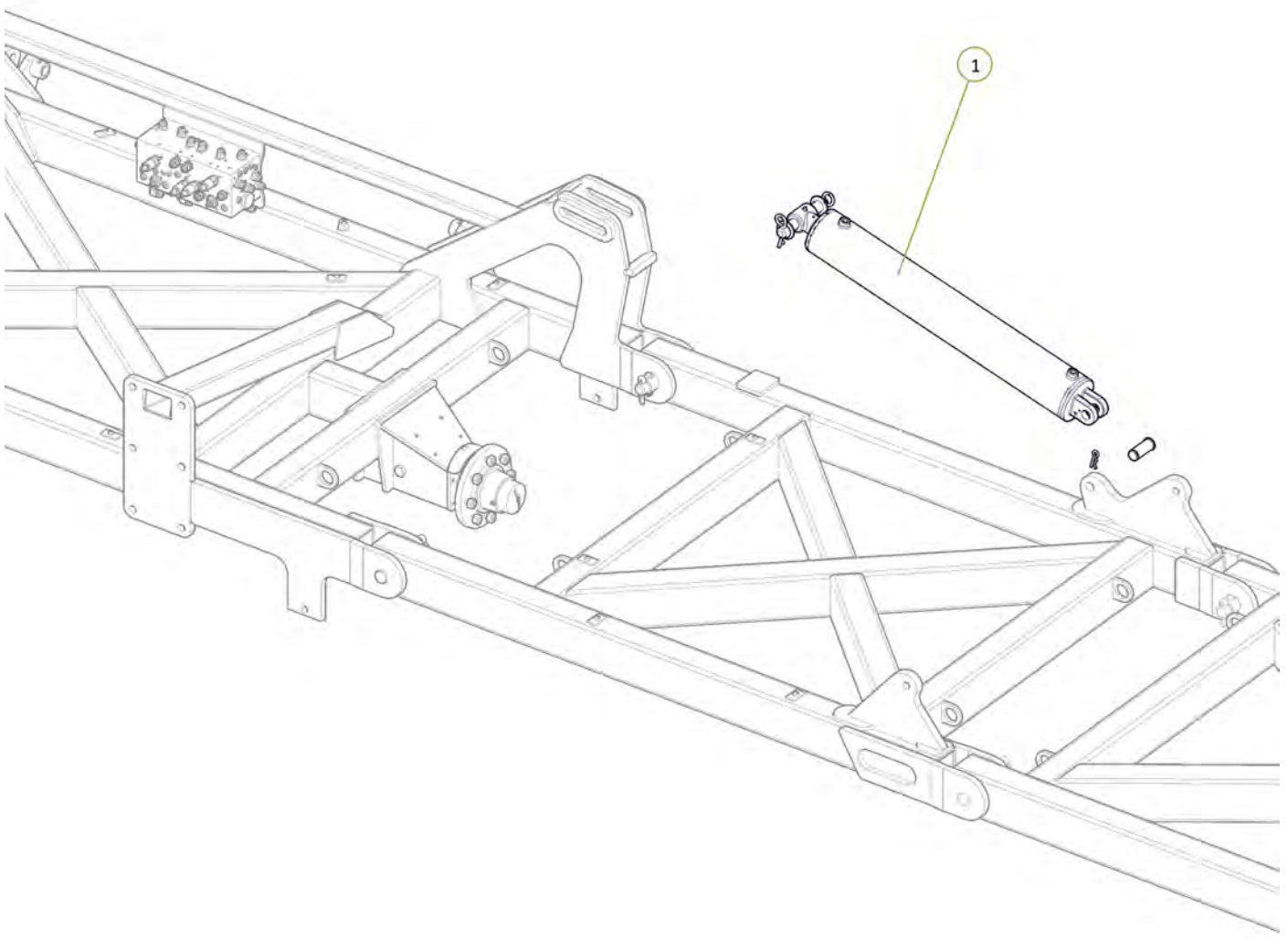
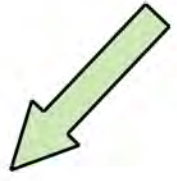

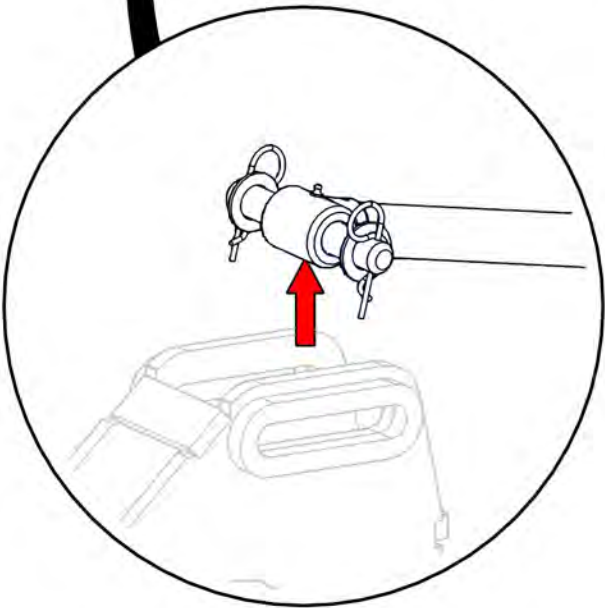
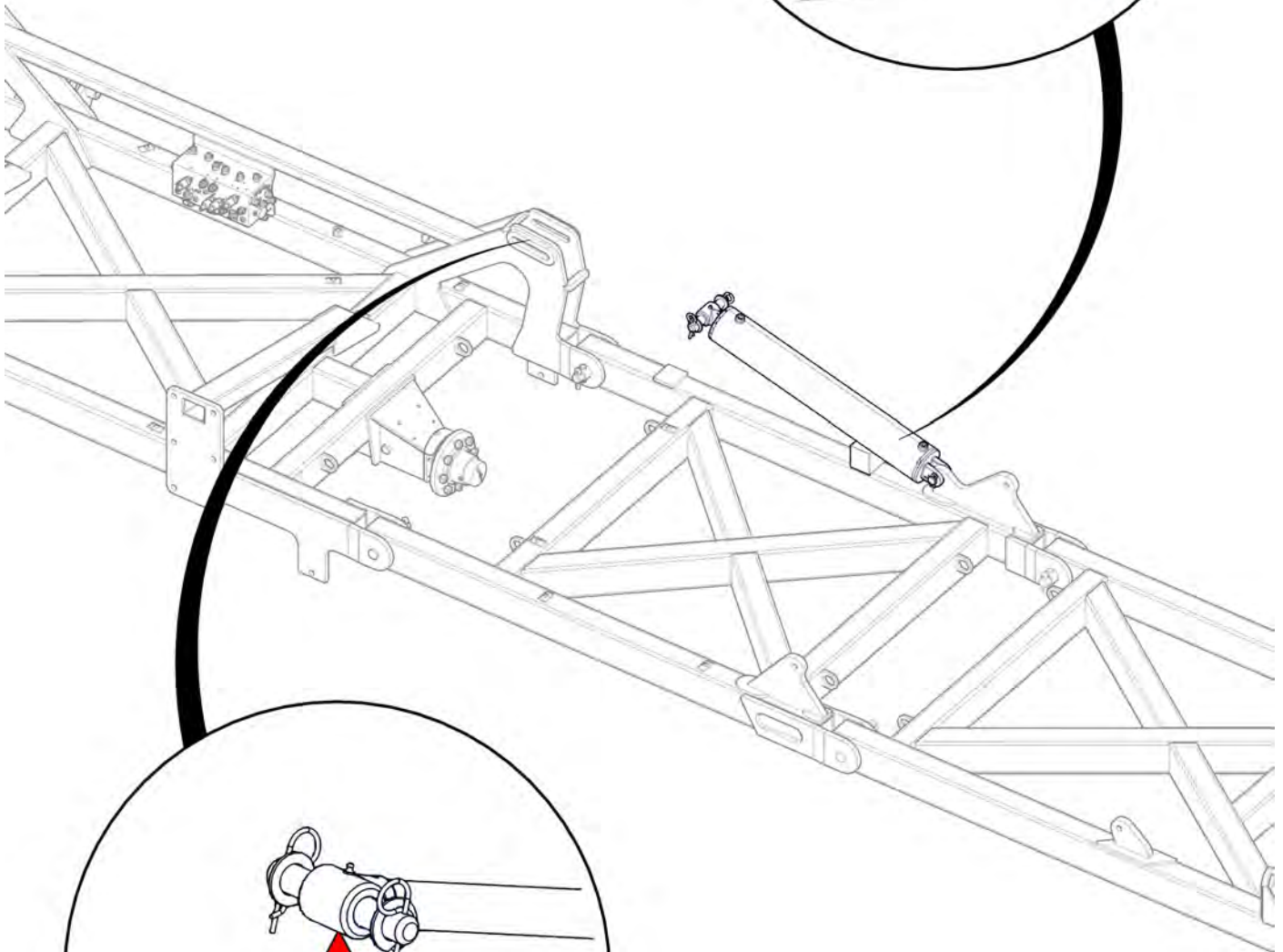
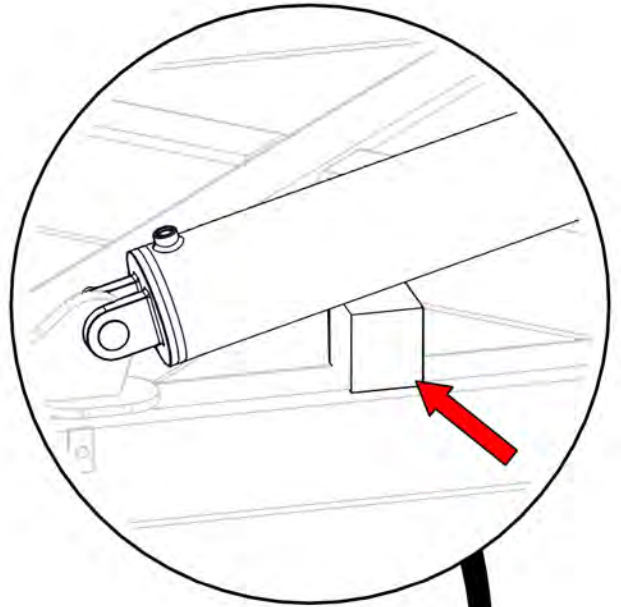



| Item No. | Description                                 | Number        | Qty |
|----------|---|---------------|-----|
| 1        | 3/4" JIC Male 3/4" UN O Ring Male 90° Elbow | 0323-S91-1212 | 2   |

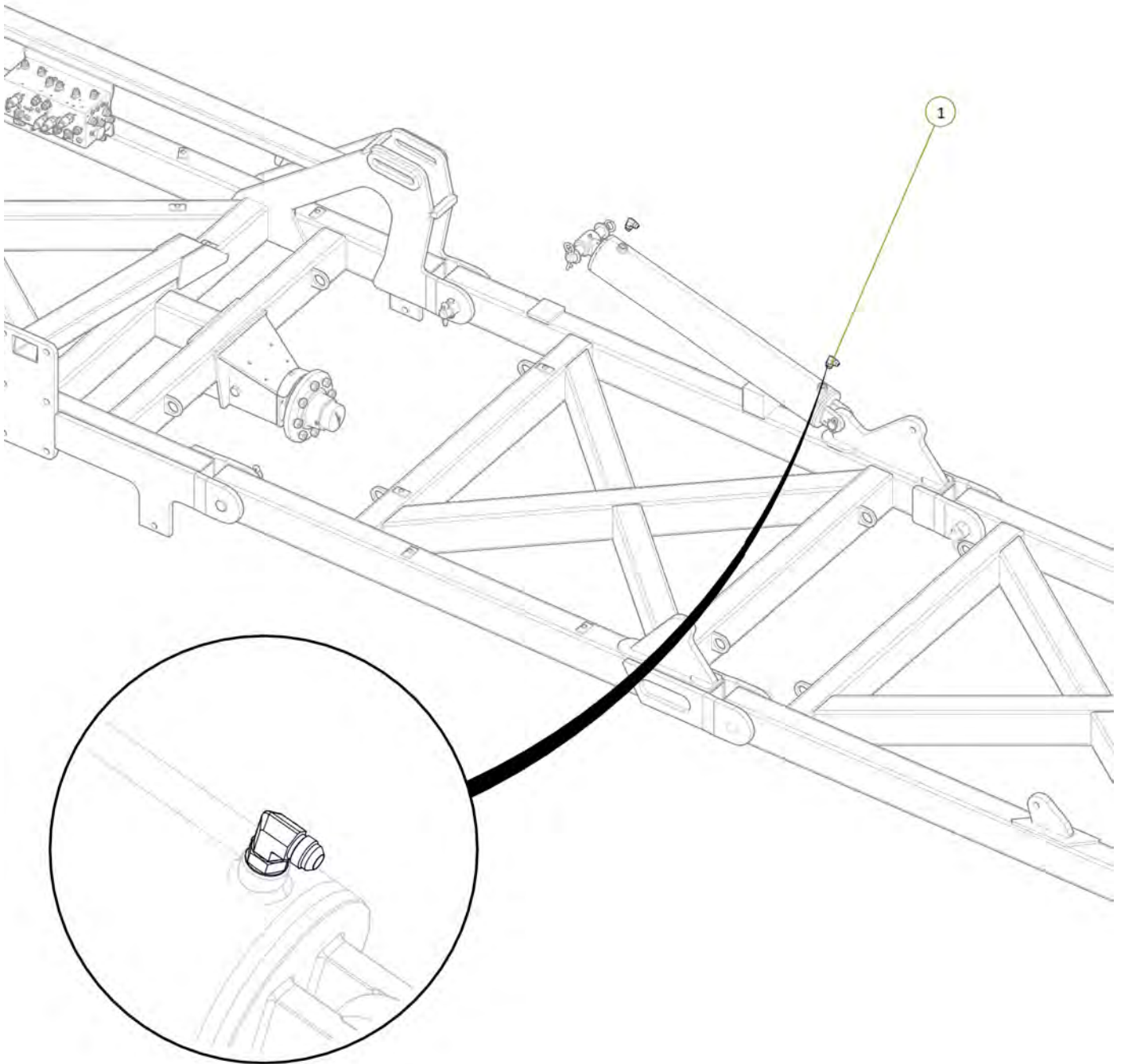
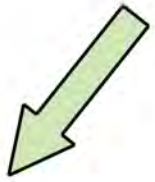

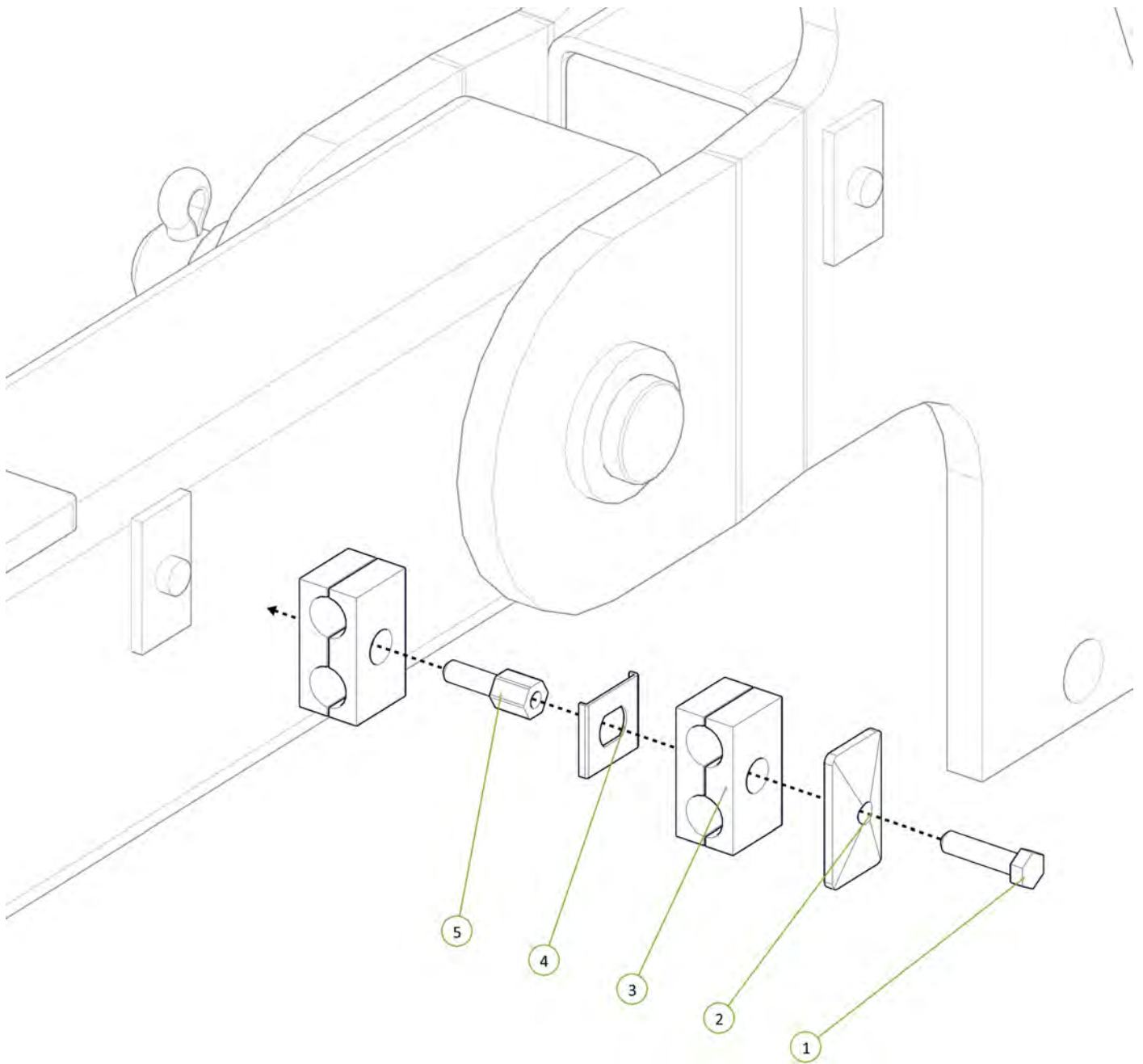

| Item No. | Description                            | Number          | Qty |
|----------|--|-----------------|-----|
| 1        | Double Clamp Bolt Group 2              | 0325-RCD-2BH    | 1   |
| 2        | Clamp top plate group 2                | 0325-RCD-2PT    | 1   |
| 3        | 17mm Clamp Jaws (Pair)                 | 0325-RCD-17J    | 2   |
| 4        | Double Clamp Stacking Plate (Non Ryco) | 0325-SI-2-5D-W3 | 1   |
| 5        | Double Clamp Stacking Bolt Group 2     | 0325-RCD-2BS    | 1   |

| Item No. | Description  | Number   | Qty |
|----------|--|----------|-----|
| 1        | Left CR Port to LH Main Wing Cylinder Retract Port | PH40-06L | 1   |
| 2        | Left CE Port to LH Main Wing Cylinder Extend Port  | PH40-07L | 1   |

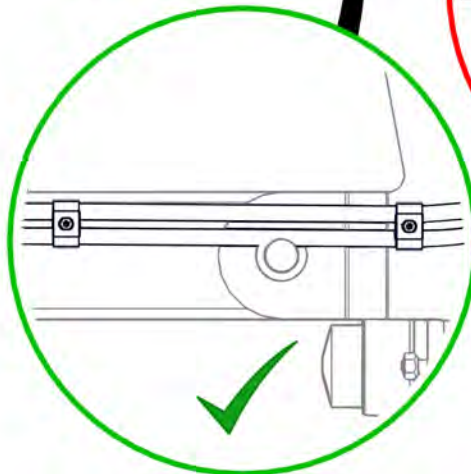
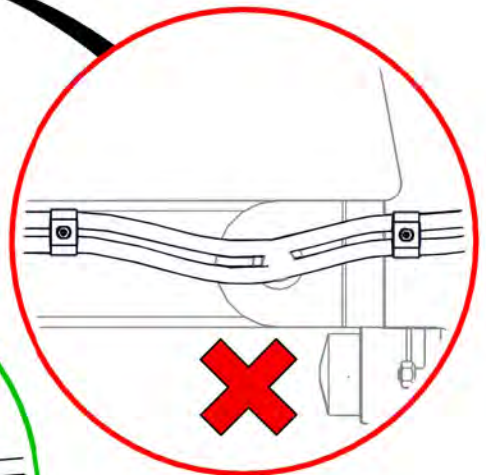
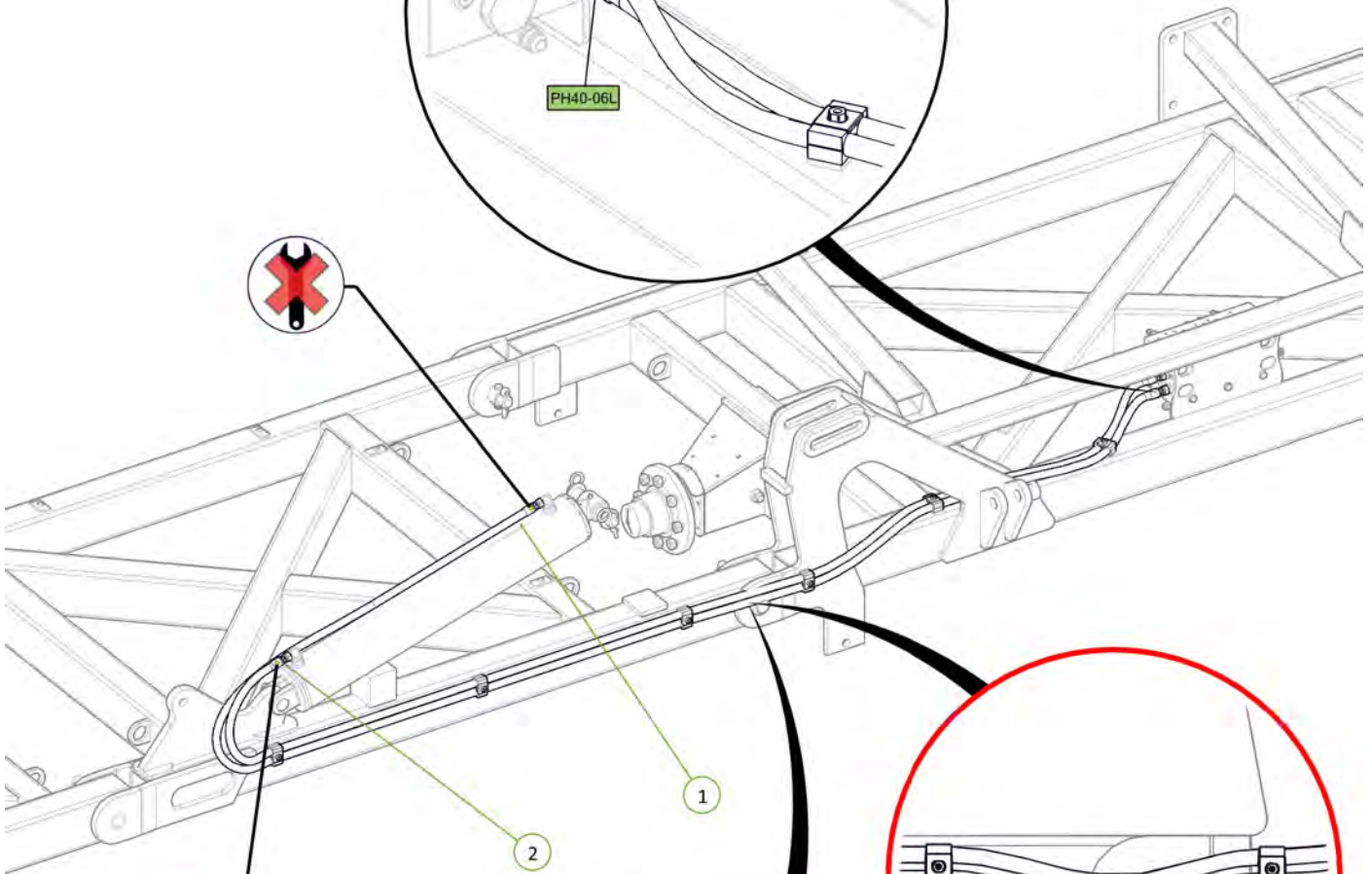
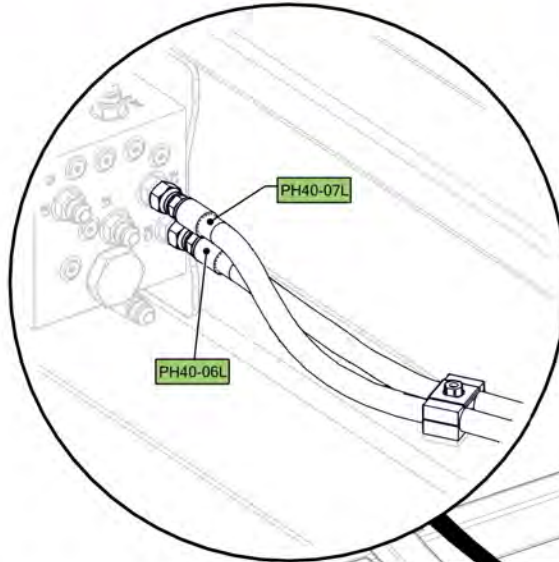

| Item No. | Description  | Number     | Qty |
|----------|--|------------|-----|
| 1        | 5" Bore 30" Stroke 3 1/8" S/Tube 2" Rod Hydraulic Cylinder | 0311-530ST | 1   |

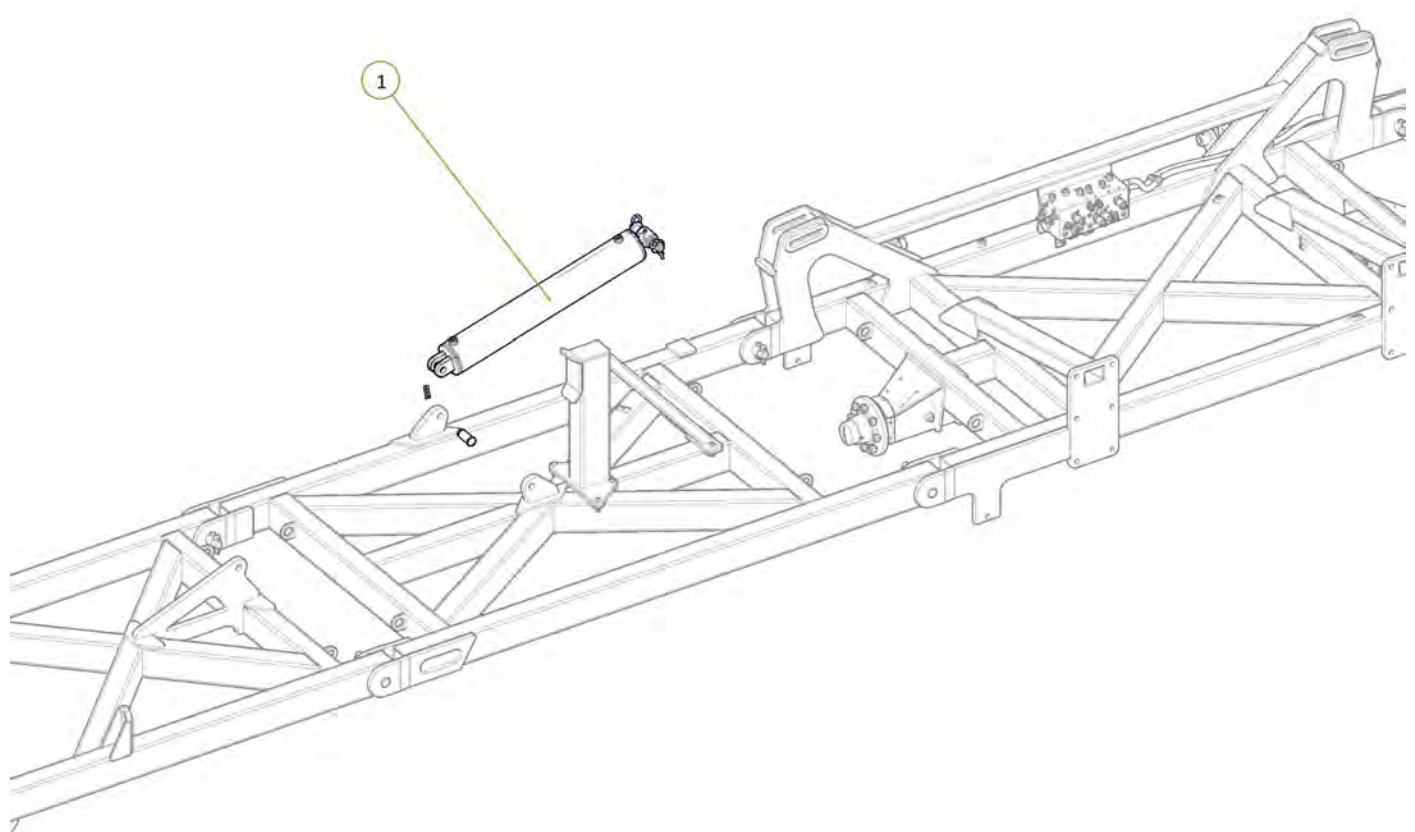



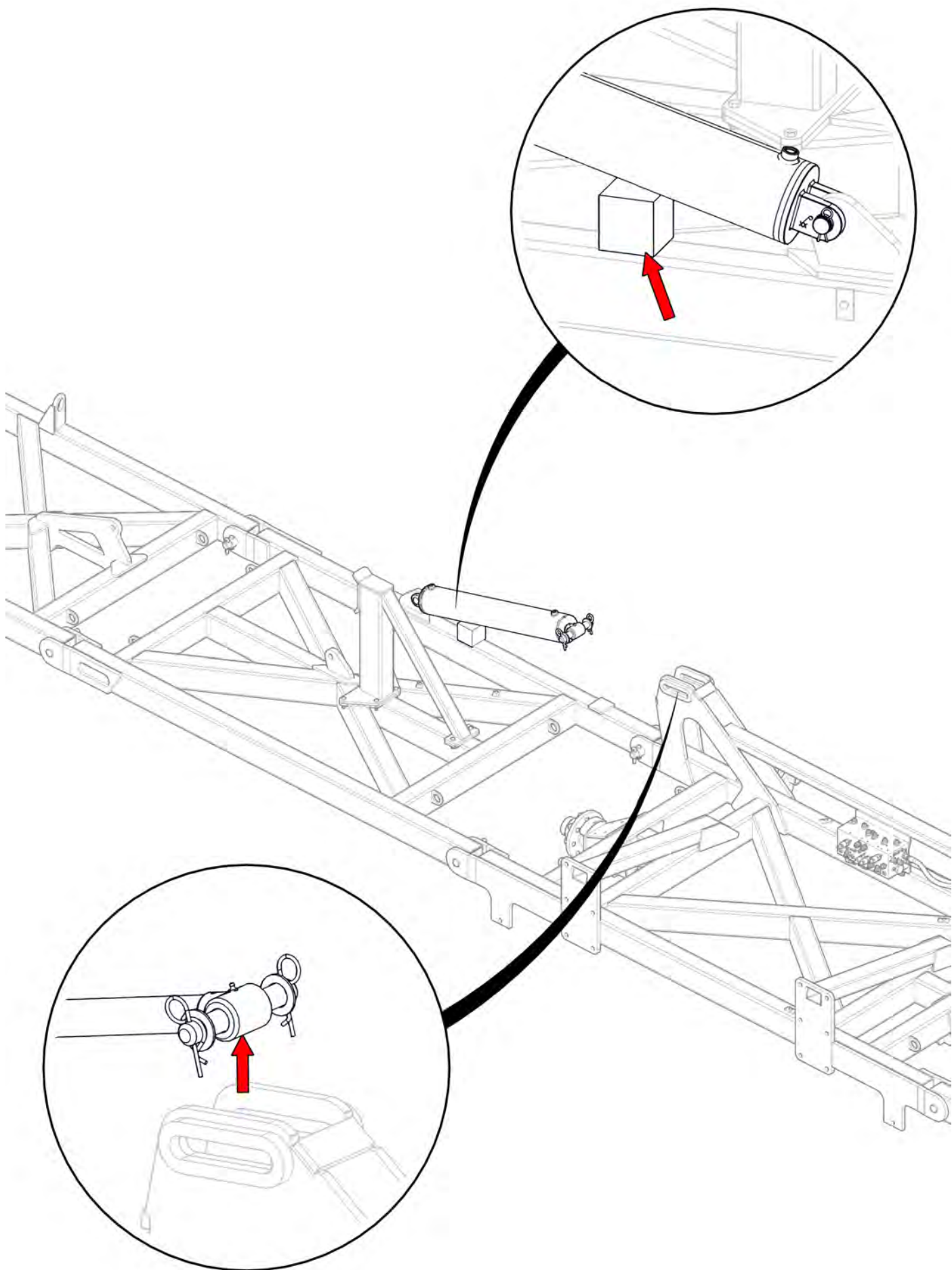

| Item No. | Description                                 | Number        | Qty |
|----------|---|---------------|-----|
| 1        | 3/4" JIC Male 3/4" UN O Ring Male 90° Elbow | 0323-S91-1212 | 2   |

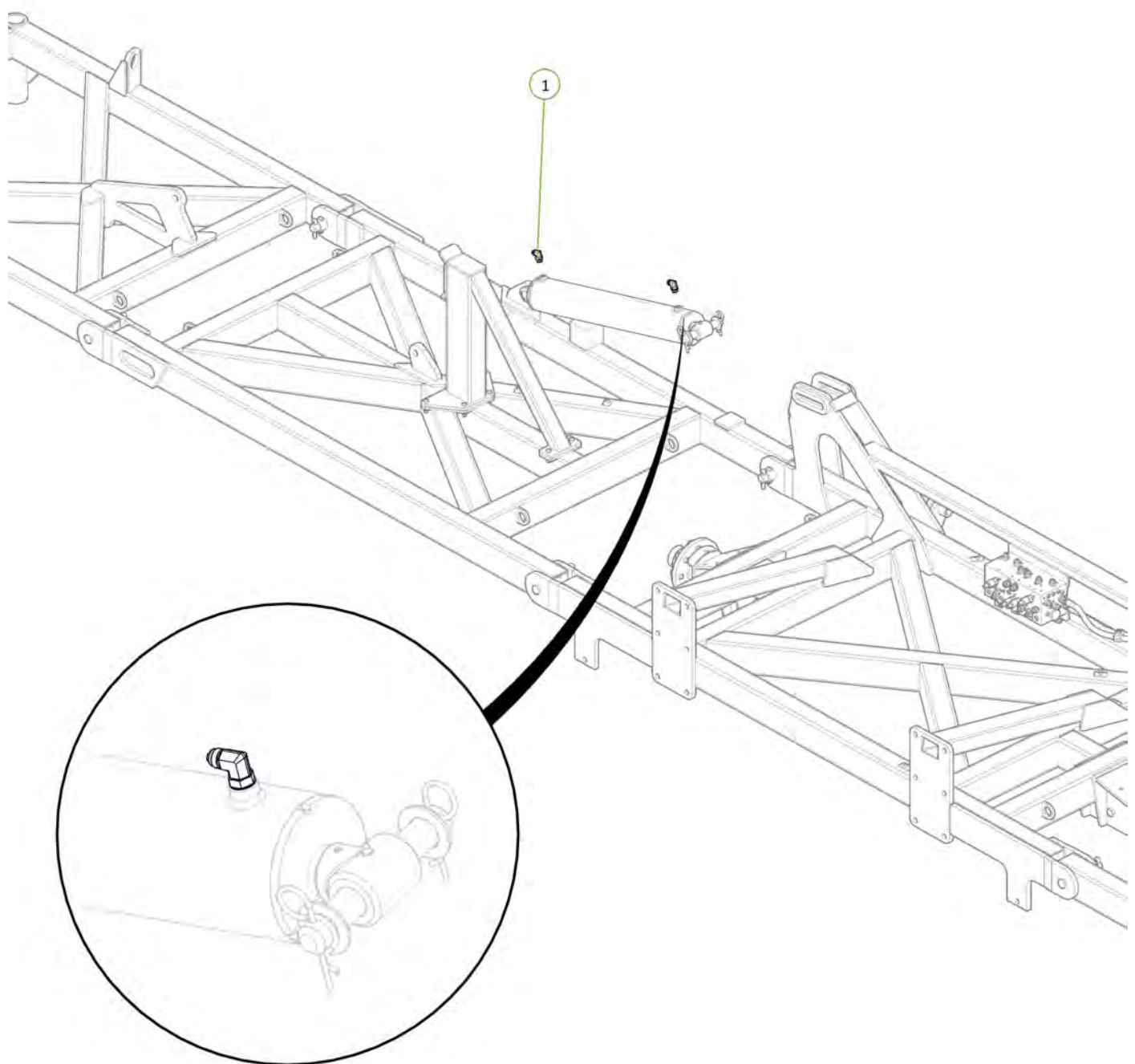

| Item No. | Description   | Number   | Qty |
|----------|---|----------|-----|
| 1        | Right CR Port to RH Main Wing Cylinder Retract Port | PH40-06R | 1   |
| 2        | Right CE Port to RH Main Wing Cylinder Extend Port  | PH40-07R | 1   |

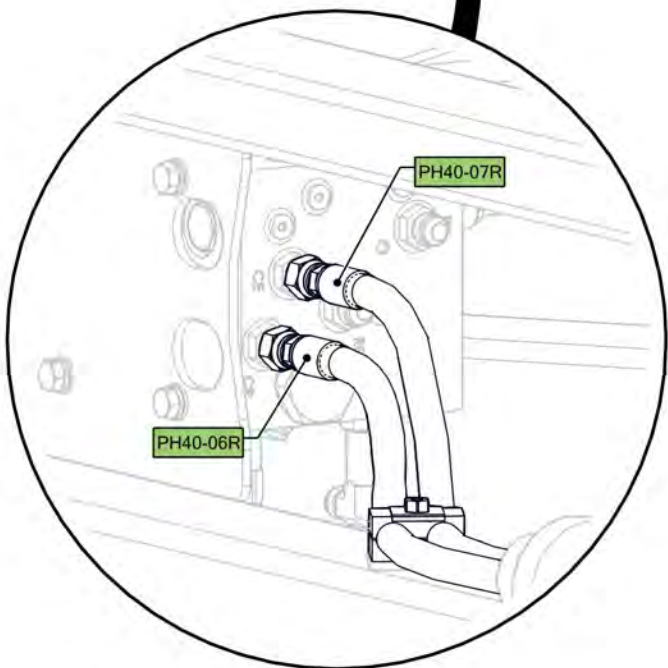
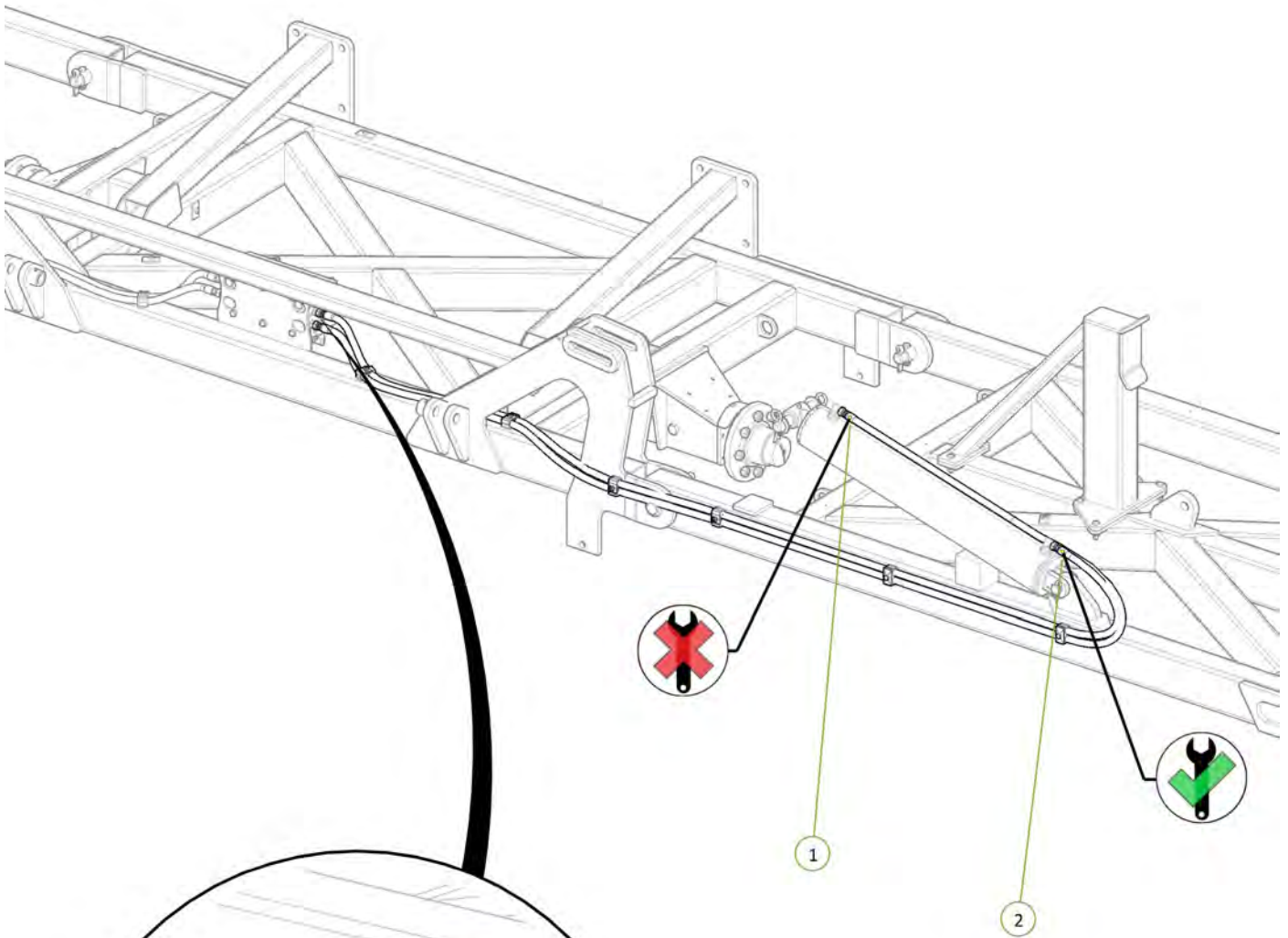



| Item No. | Description                                      | Number   | Qty |
|----------|--|----------|-----|
| 1        | 3" Bore x 24" Stroke 1.5" Rod Hydraulic Cylinder | 0311-324 | 2   |

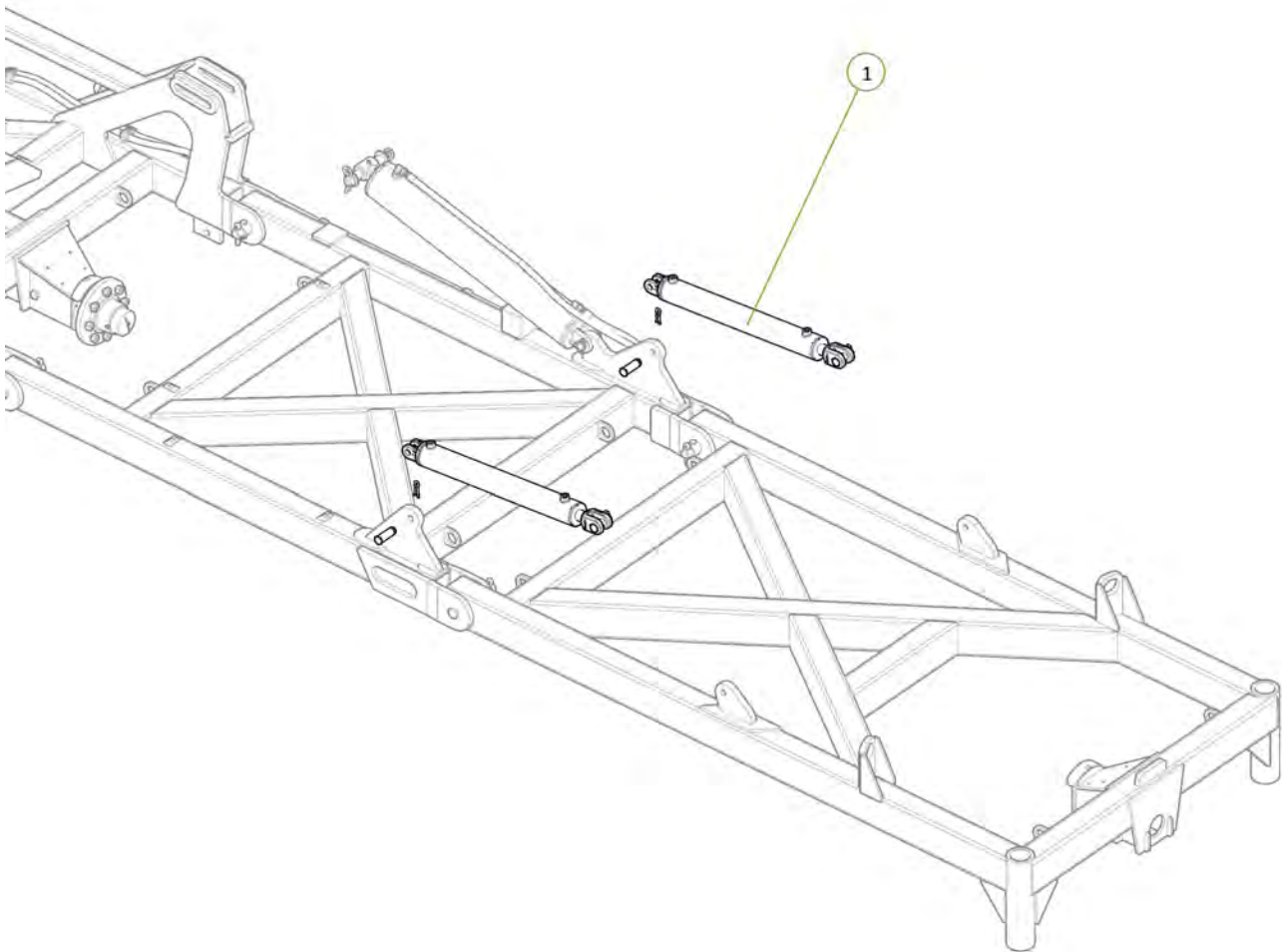

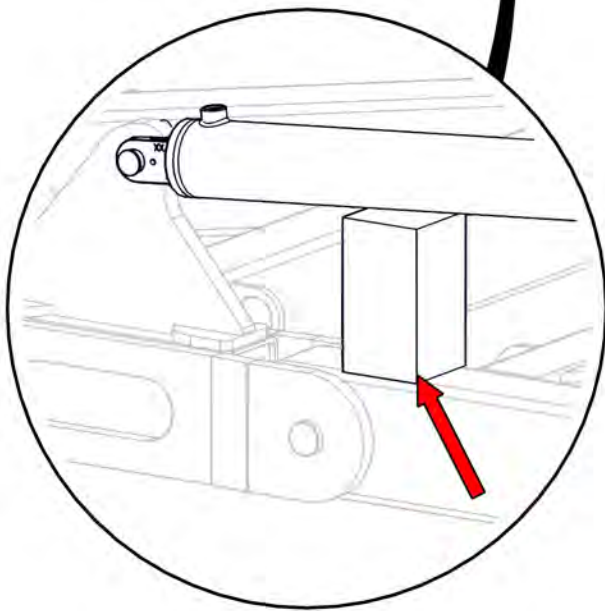
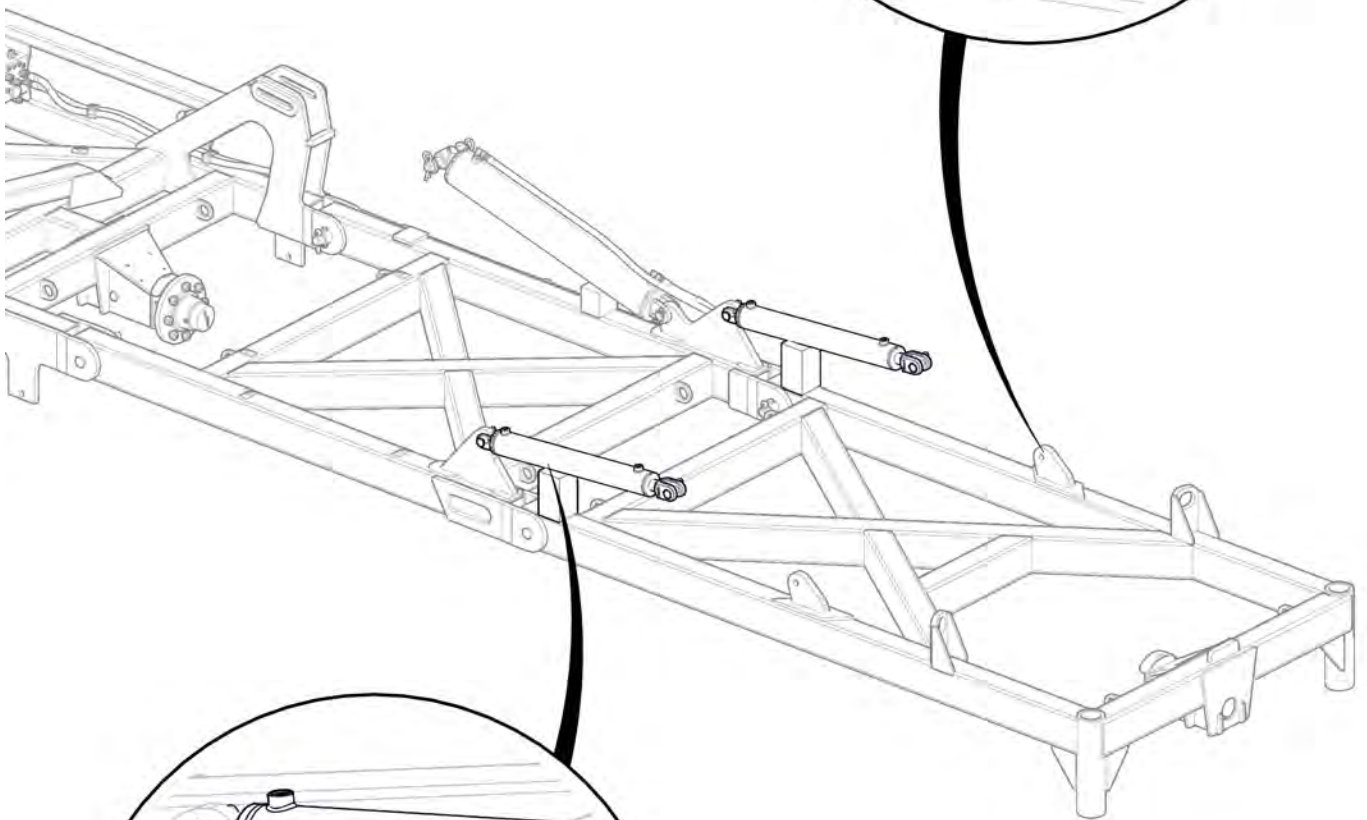
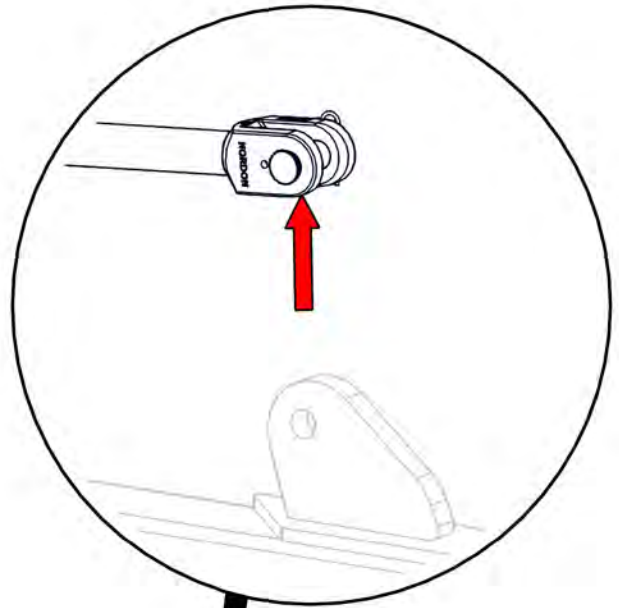

| Item No. | Description                                 | Number        | Qty |
|----------|---|---------------|-----|
| 1        | 3/4" JIC Male 3/4" UN O Ring Male 90° Elbow | 0323-S91-1212 | 4   |

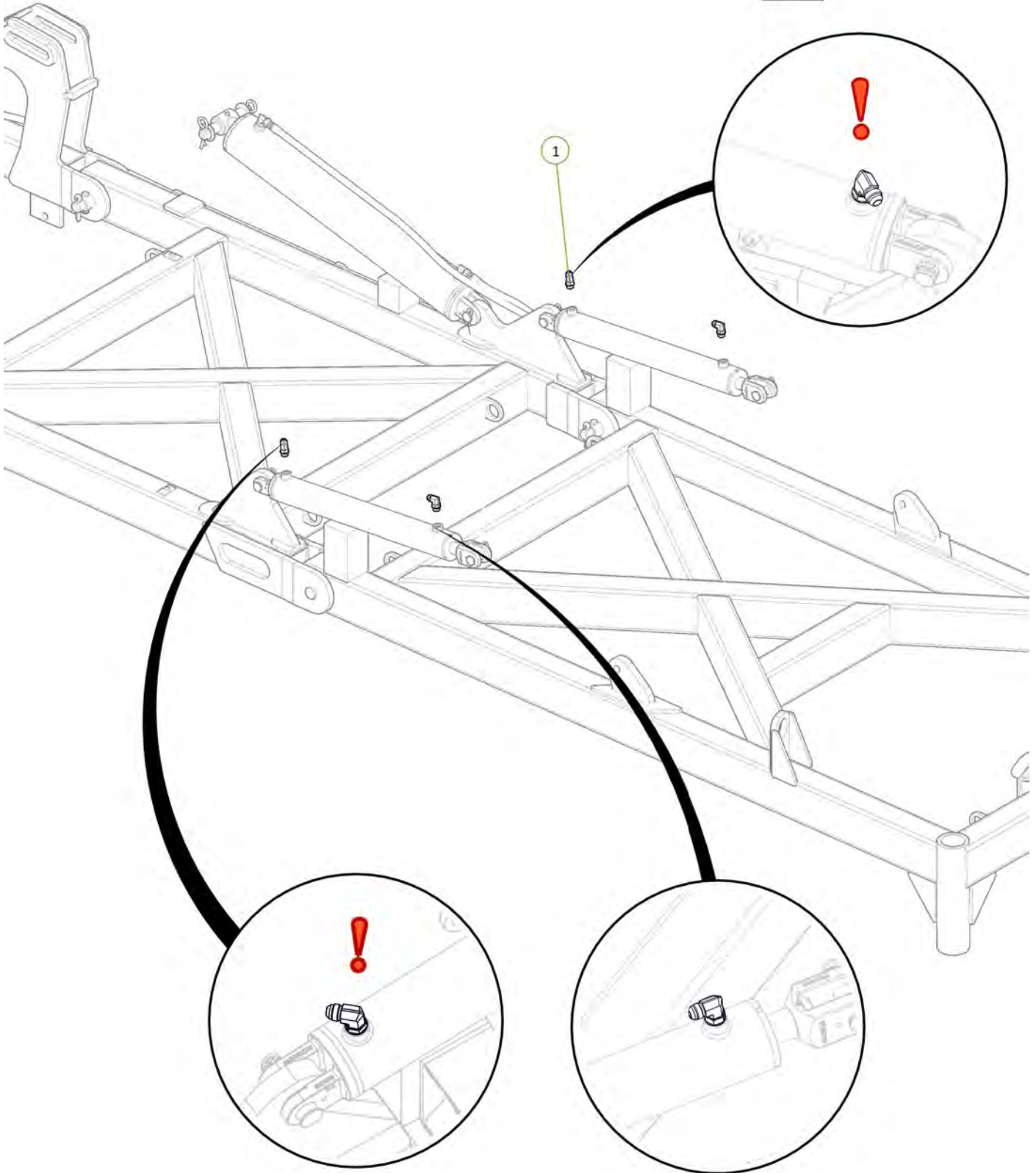

| Item No. | Description   | Number          | Qty |
|----------|---|-----------------|-----|
| 1        | LR port to LH Wing Retract Tee                        | PH40-08L        | 1   |
| 2        | LE Port to LH Wing Extend Tee                         | PH40-09L        | 1   |
| 3        | 3/4" JIC Male Tee 3/4" JIC Male Tee 3/4" JIC Male Tee | 0324-S19-121212 | 2   |
| 4        | 3/4" JIC Male 3/4" JIC Female Swivel 90° Elbow        | 0323-S15-1212   | 1   |

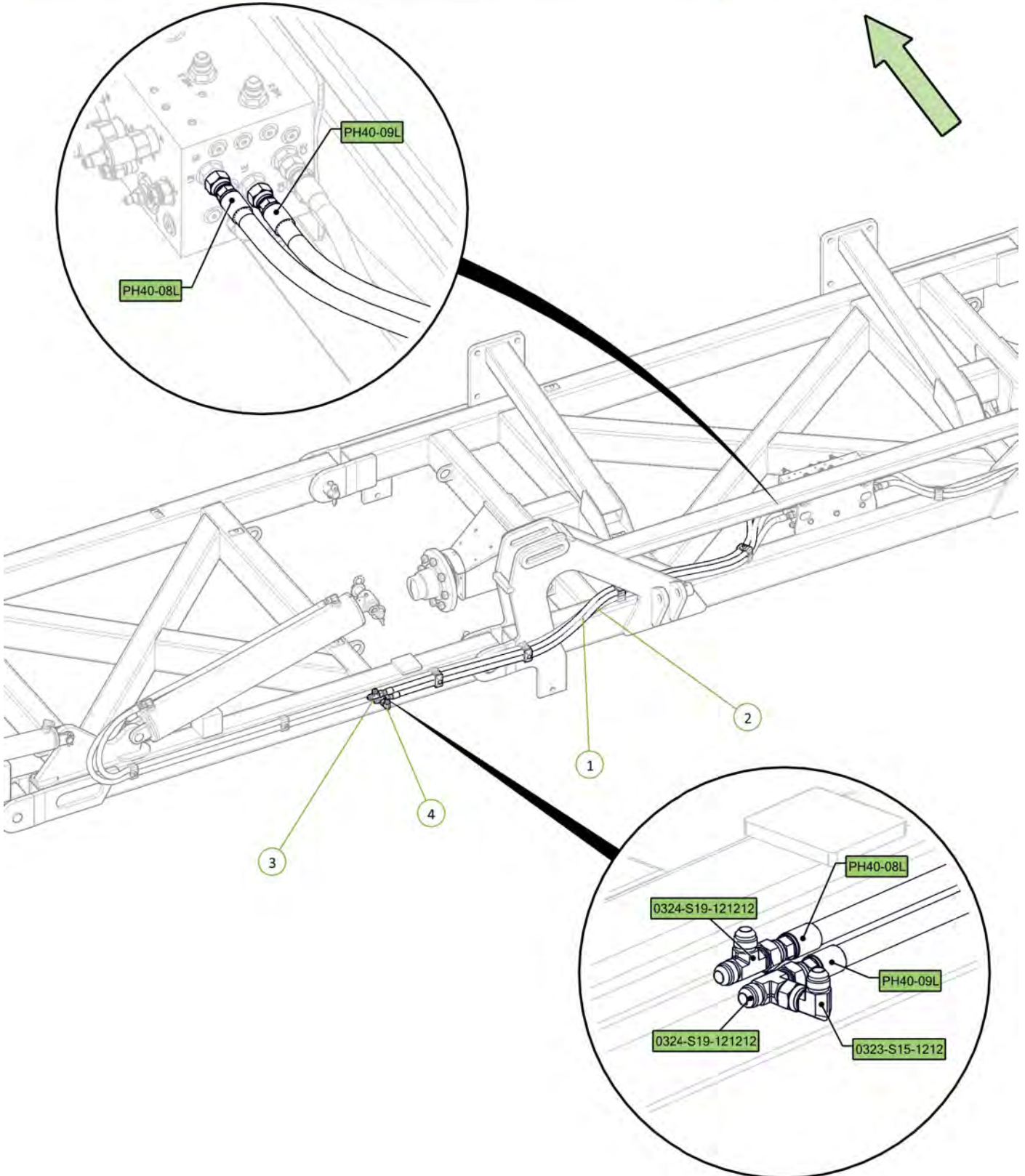



| Item No. | Description   | Number  | Qty |
|----------|---|---------|-----|
| 1        | LH Wing Extend Tee to Rear LH Outer Wing Cylinder Extend Port   | PH40-12 | 1   |
| 2        | LH Wing Retract Tee to Rear LH Outer Wing Cylinder Retract Port | PH40-13 | 1   |

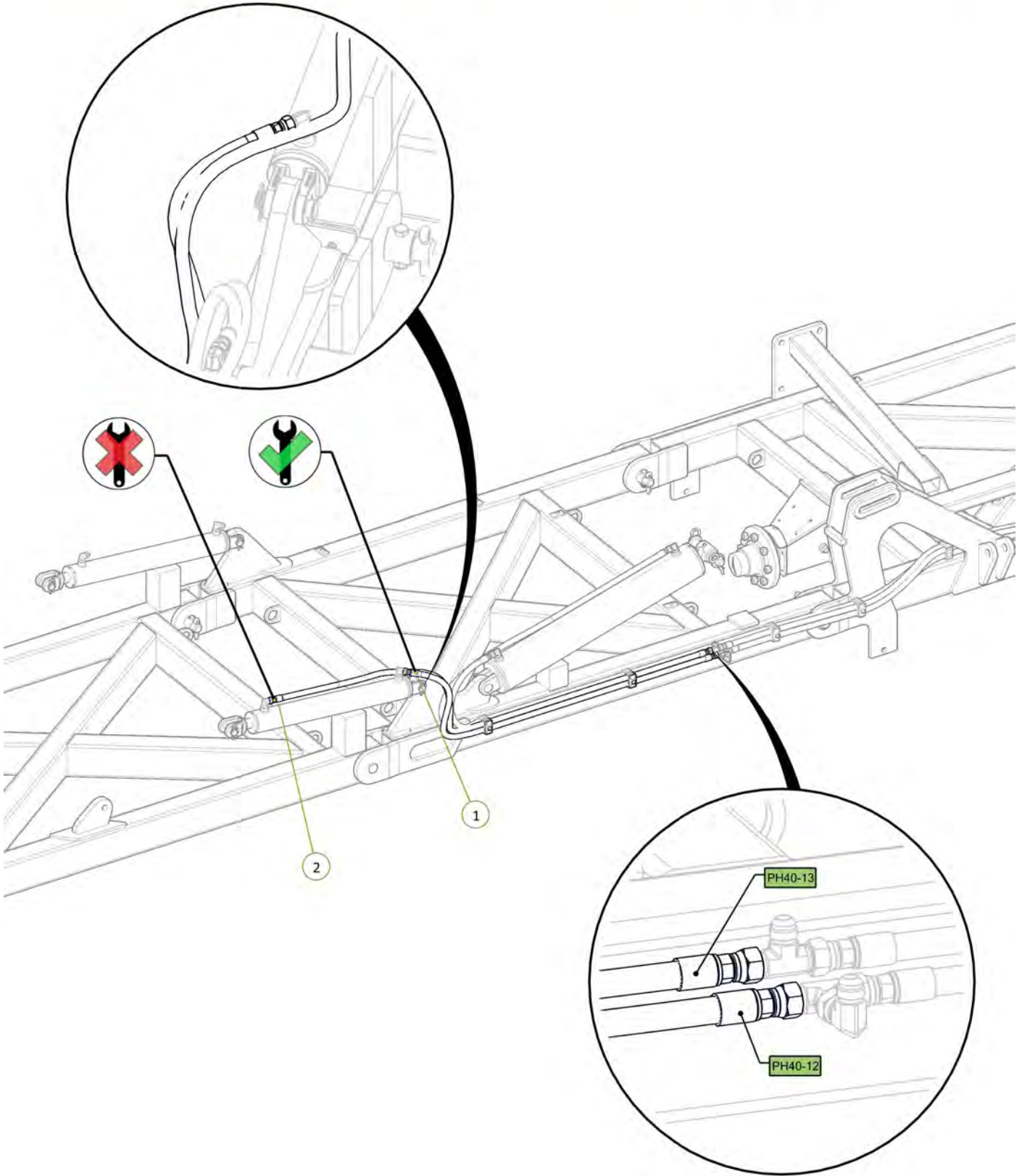

| Item No. | Description  | Number  | Qty |
|----------|--|---------|-----|
| 1        | LH Wing Extend Tee to Front LH Outer Wing Cylinder Extend Port   | PH40-10 | 1   |
| 2        | LH Wing Retract Tee to Front LH Outer Wing Cylinder Retract Port | PH40-11 | 1   |

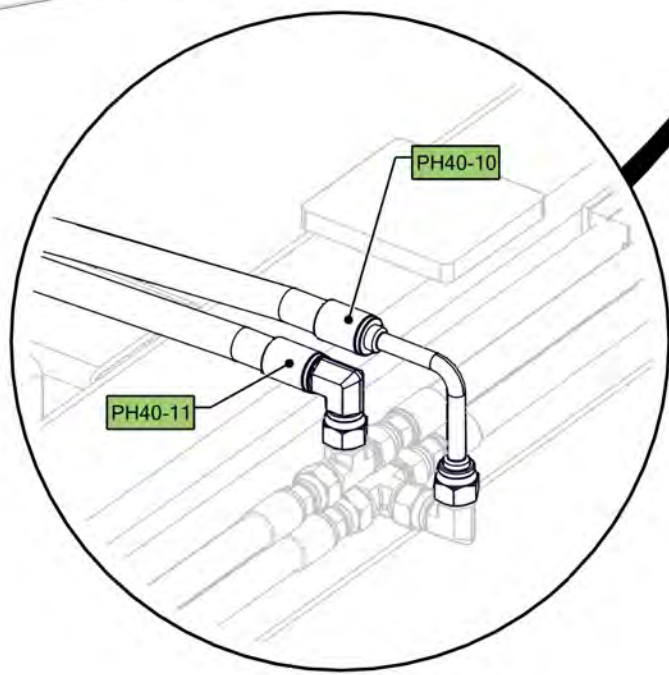
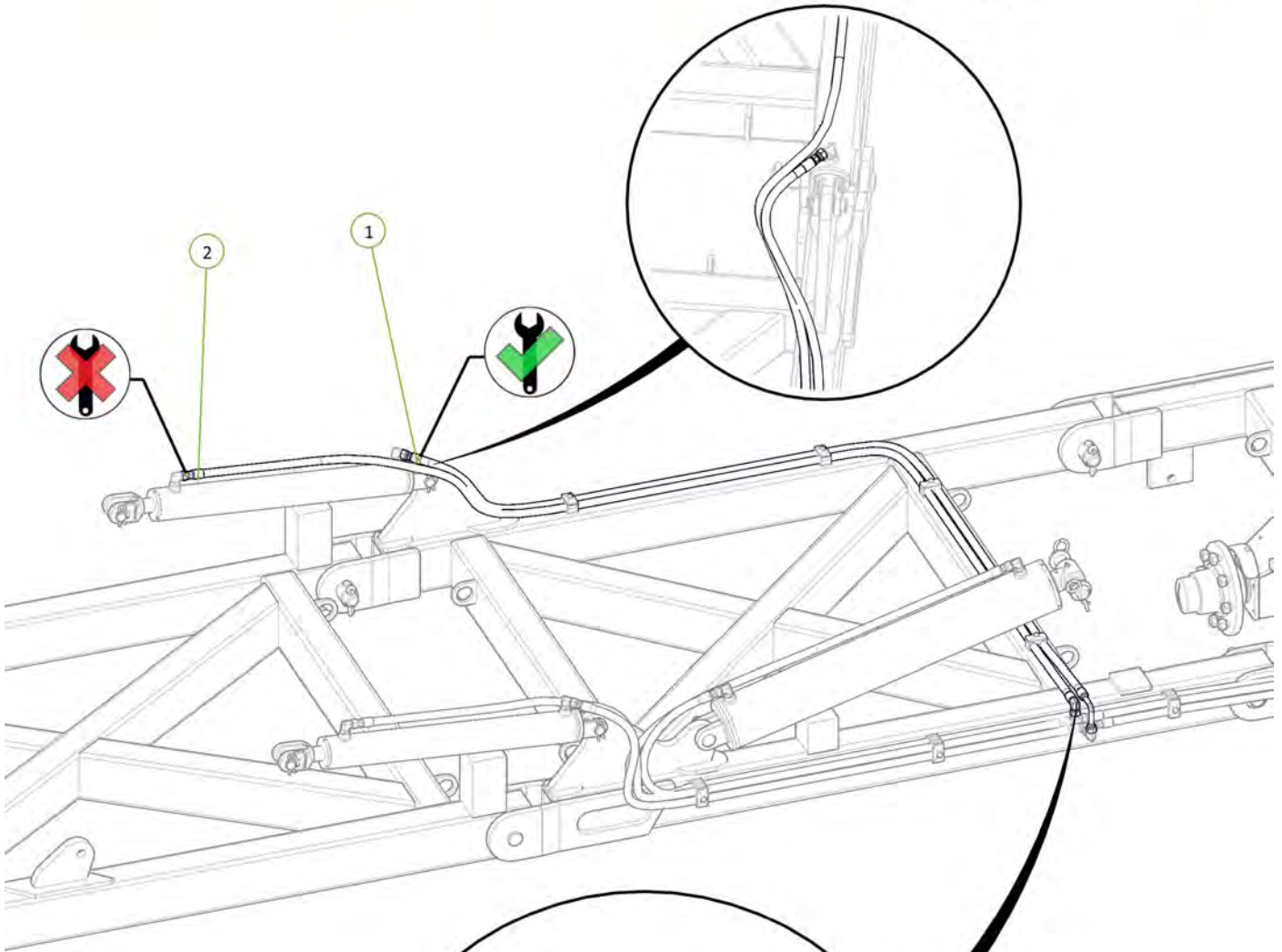

| Item No. | Description                                     | Number   | Qty |
|----------|---|----------|-----|
| 1        | 4" Bore 24" Stroke 1.75" Rod Hydraulic Cylinder | 0311-424 | 1   |

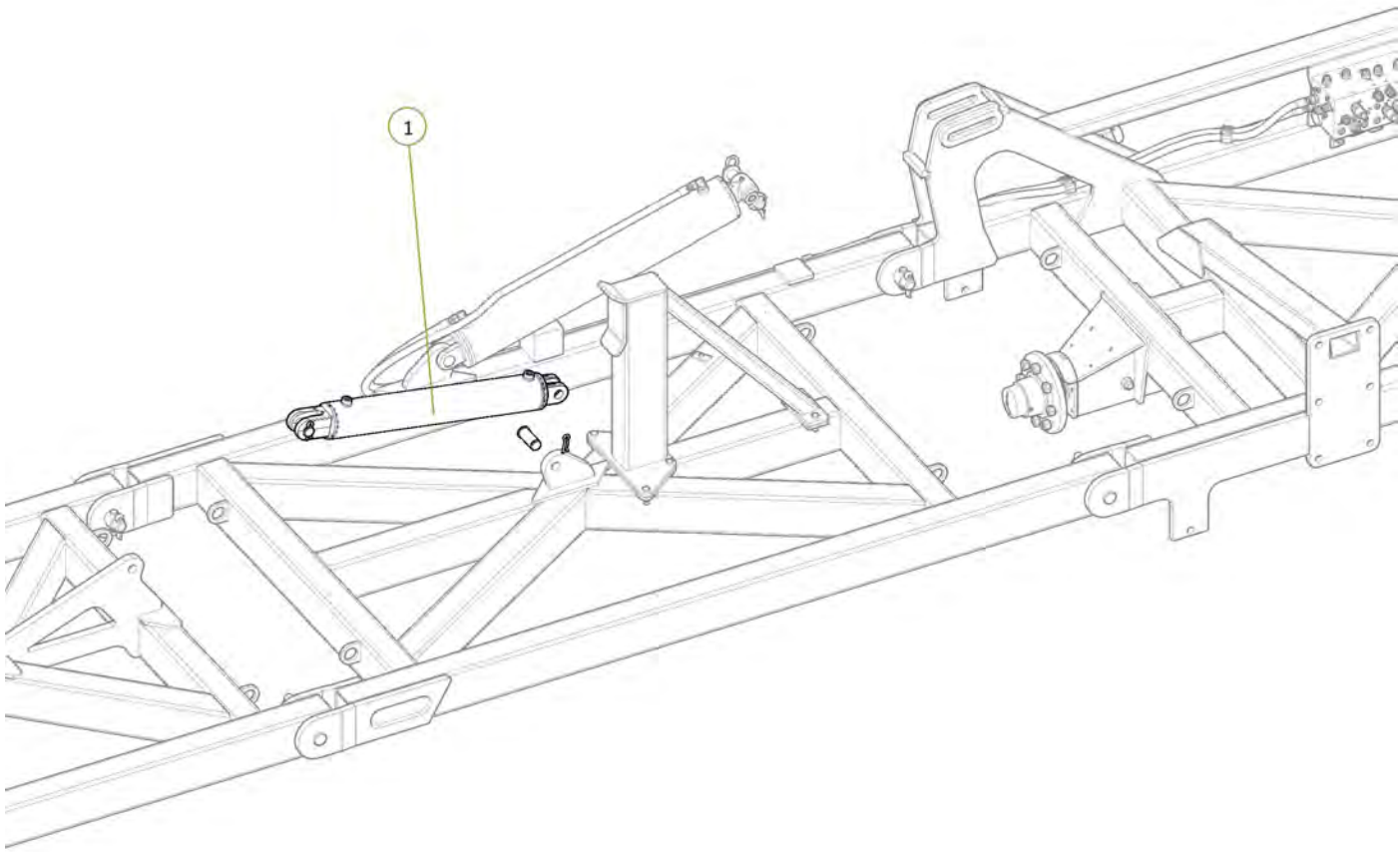



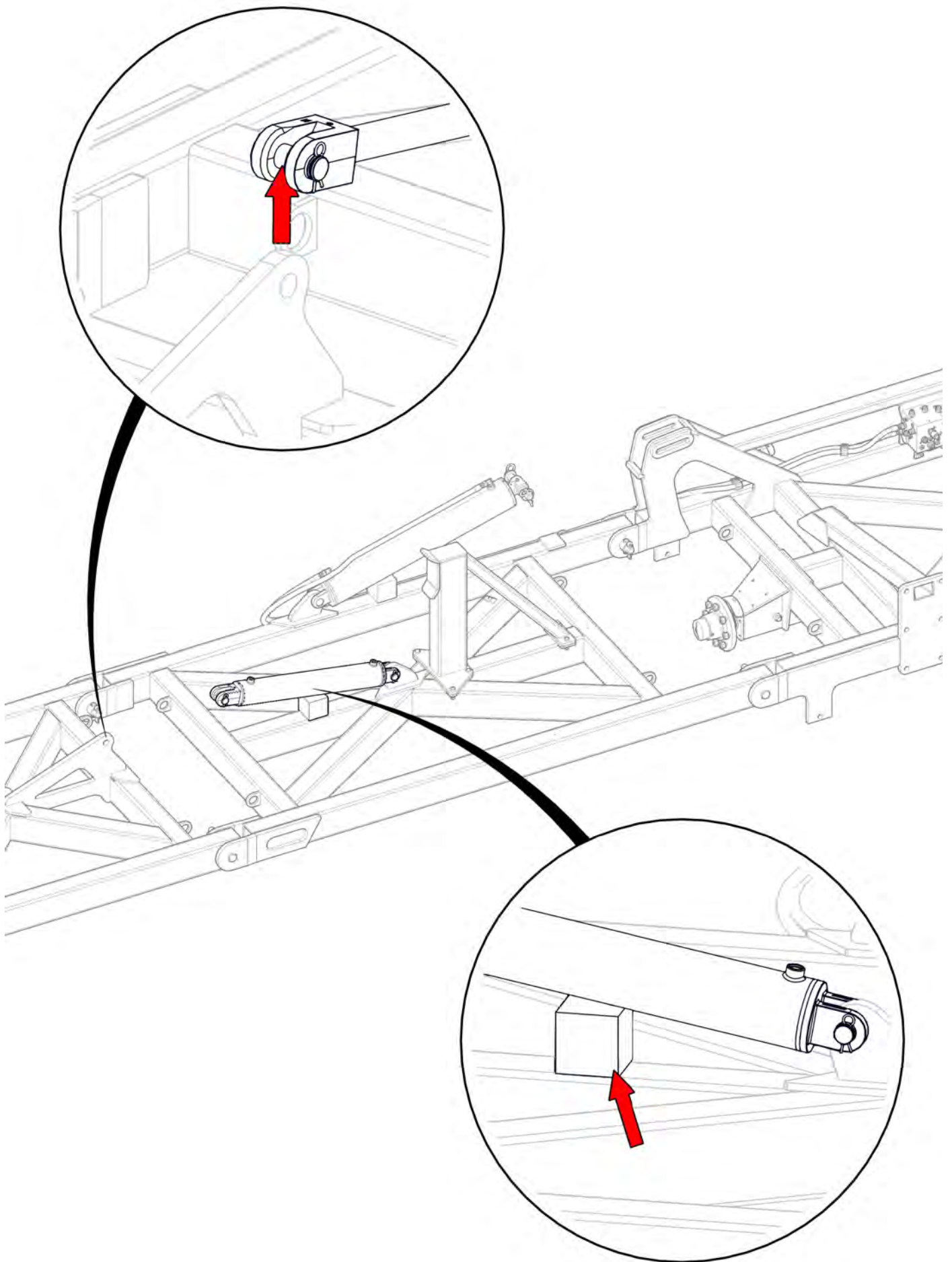

| Item No. | Description                                 | Number        | Qty |
|----------|---|---------------|-----|
| 1        | 3/4" JIC Male 3/4" UN O Ring Male 90° Elbow | 0323-S91-1212 | 2   |

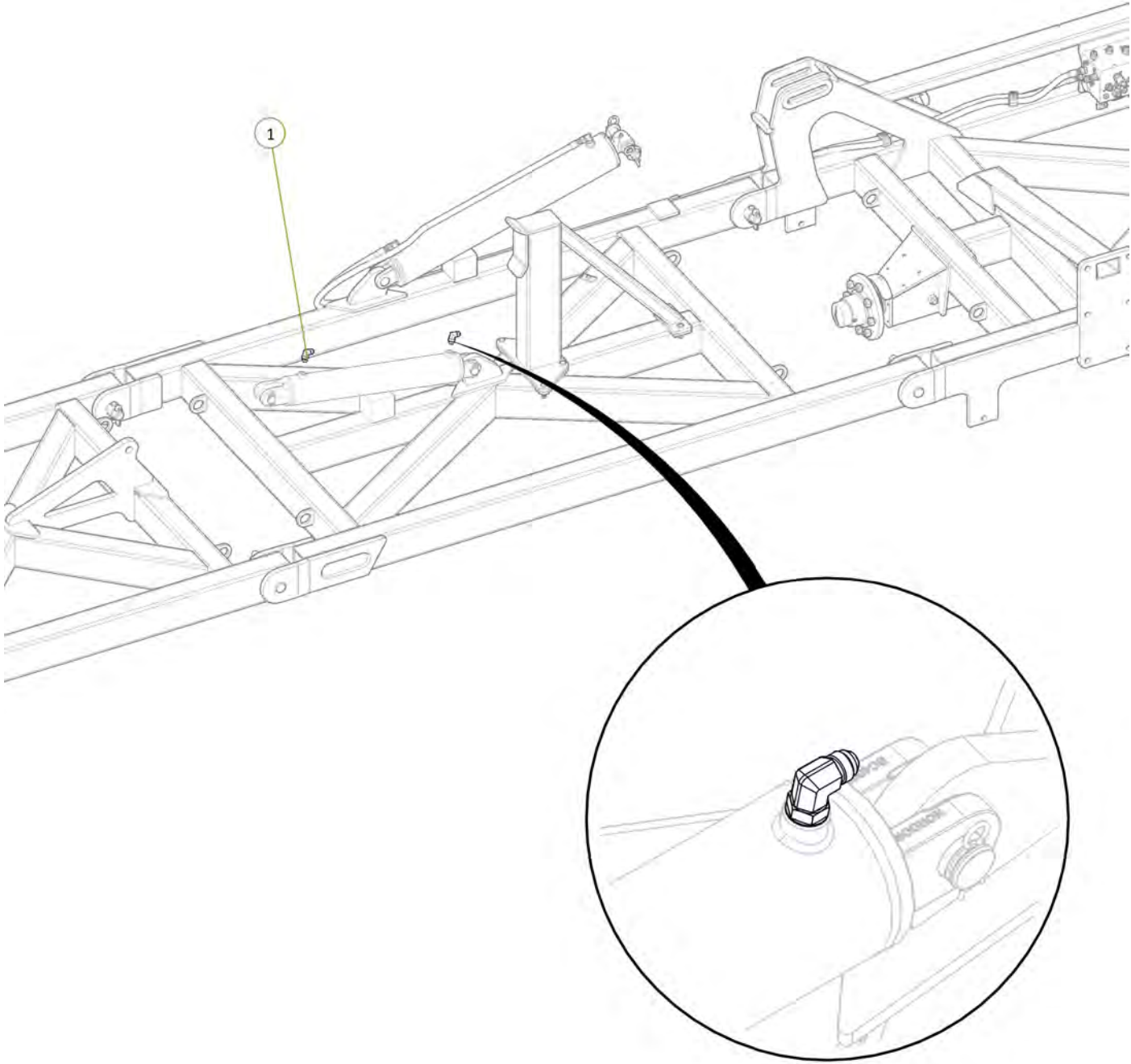

| Item No. | Description                                    | Number   | Qty |
|----------|--|----------|-----|
| 1        | RR Port to RH Outer Wing Cylinder Retract Port | PH40-08R | 1   |
| 2        | RE Port to RH Outer Wing Cylinder Extend Port  | PH40-09R | 1   |

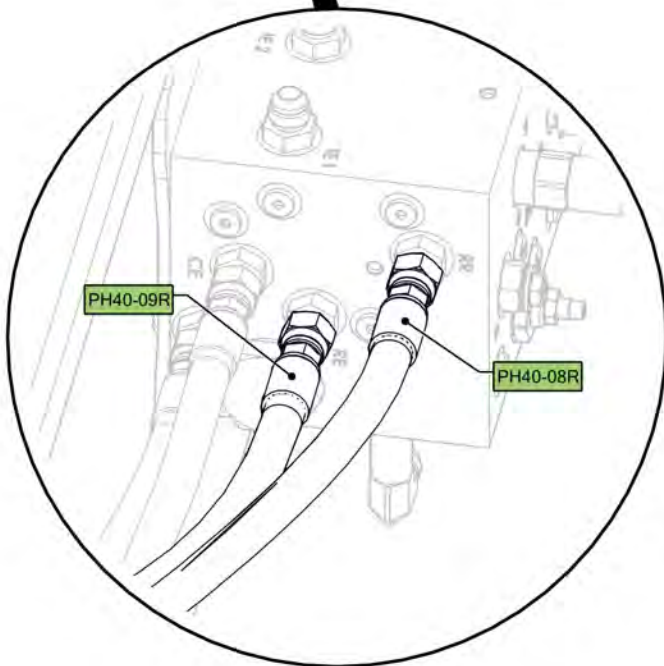
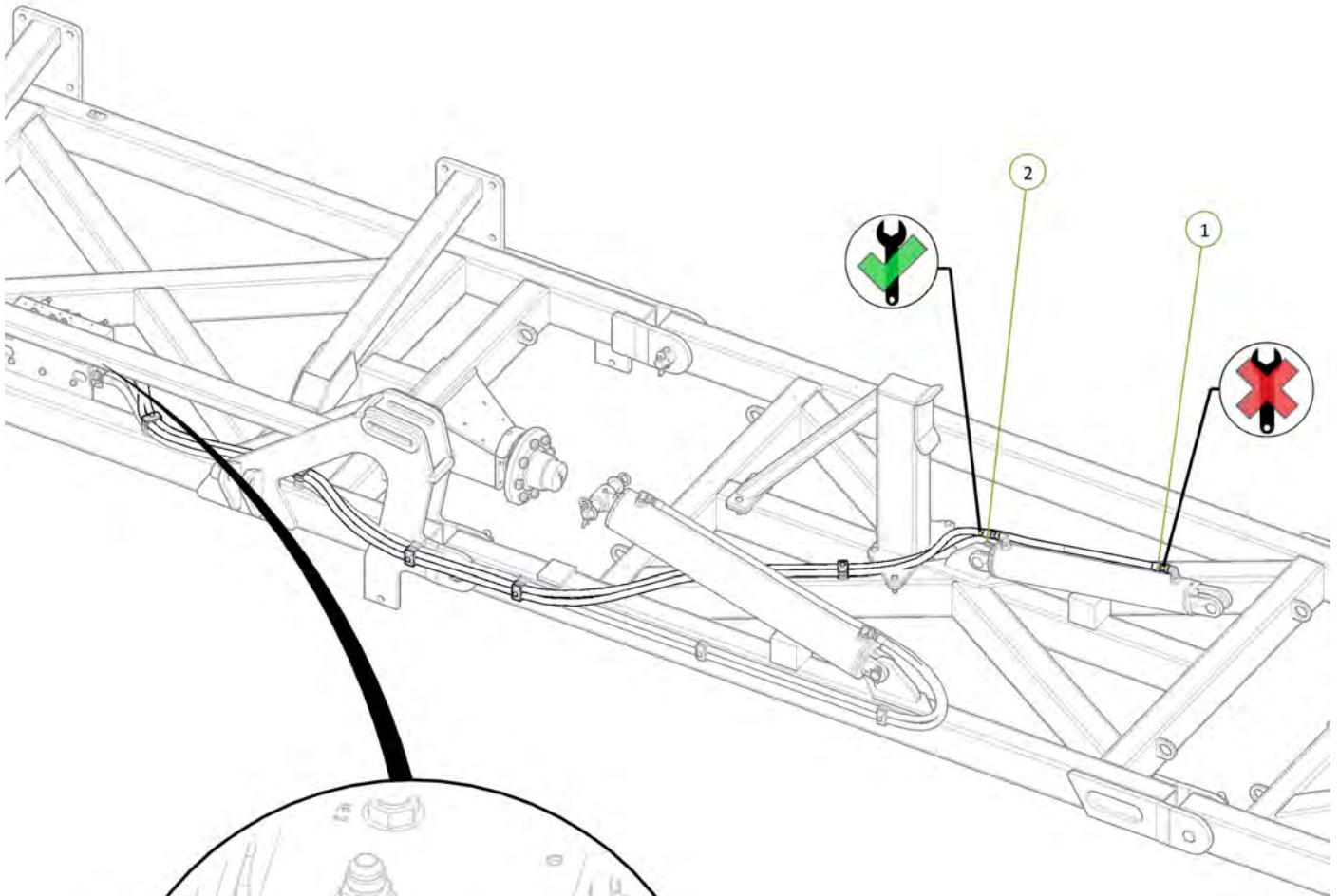



| Item No. | Description   | Number          | Qty |
|----------|---|-----------------|-----|
| 1        | Tractor to Sequence Valve EXT1 Port Fitted with Green Extend Decal  | PH40-01-GE-EXT1 | 1   |
| 2        | Tractor to Sequence Valve RCT1 Port Fitted with Green Retract Decal | PH40-01-GR-RCT1 | 1   |

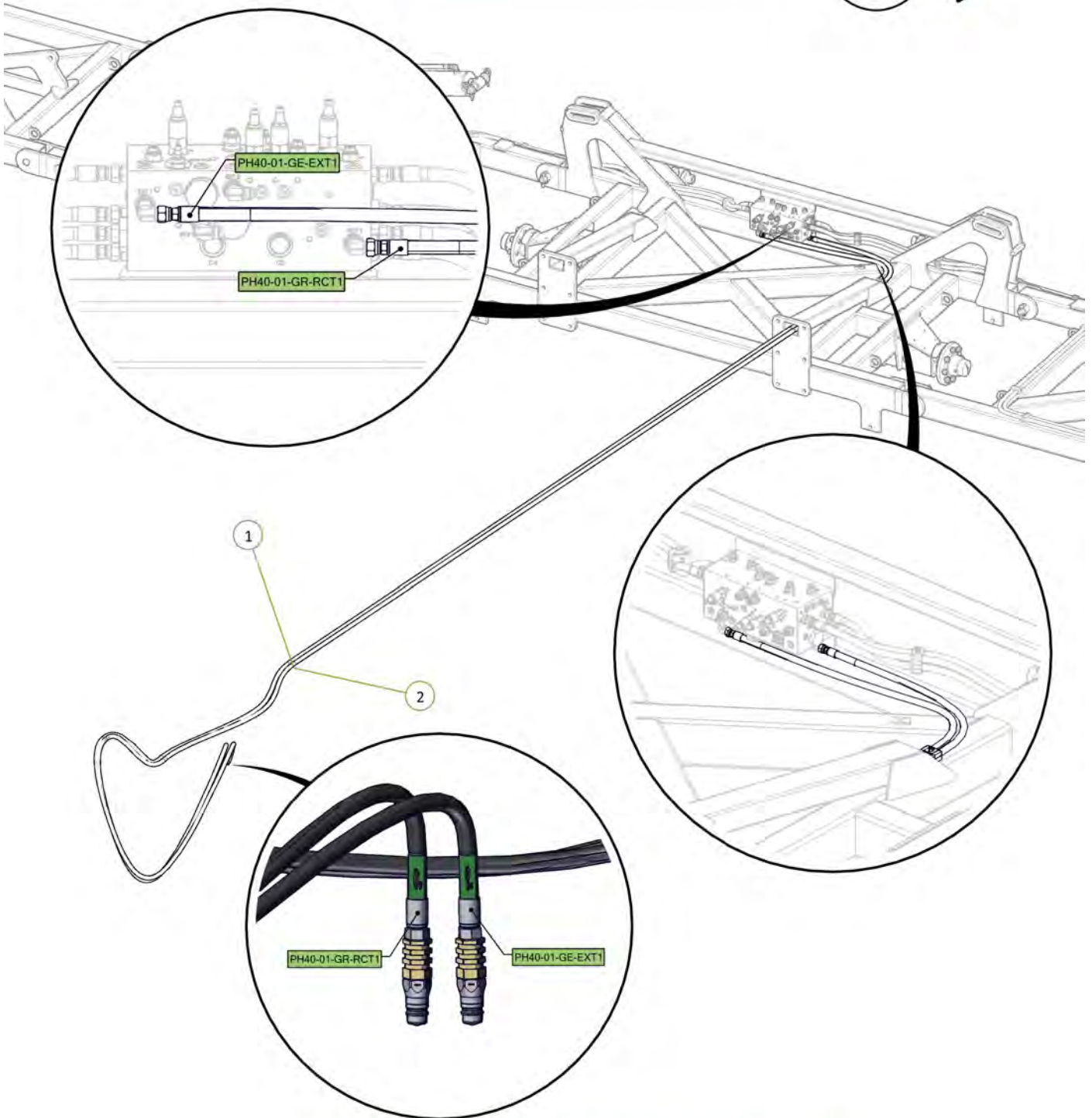

All retract hose fittings loose to allow air to escape ○

All cylinders chocked up to prevent clash during extend ○

Signed \_\_\_\_\_ Date \_\_\_\_/\_\_\_\_/\_\_\_\_  
 Unit Serial Number: \_\_\_\_\_

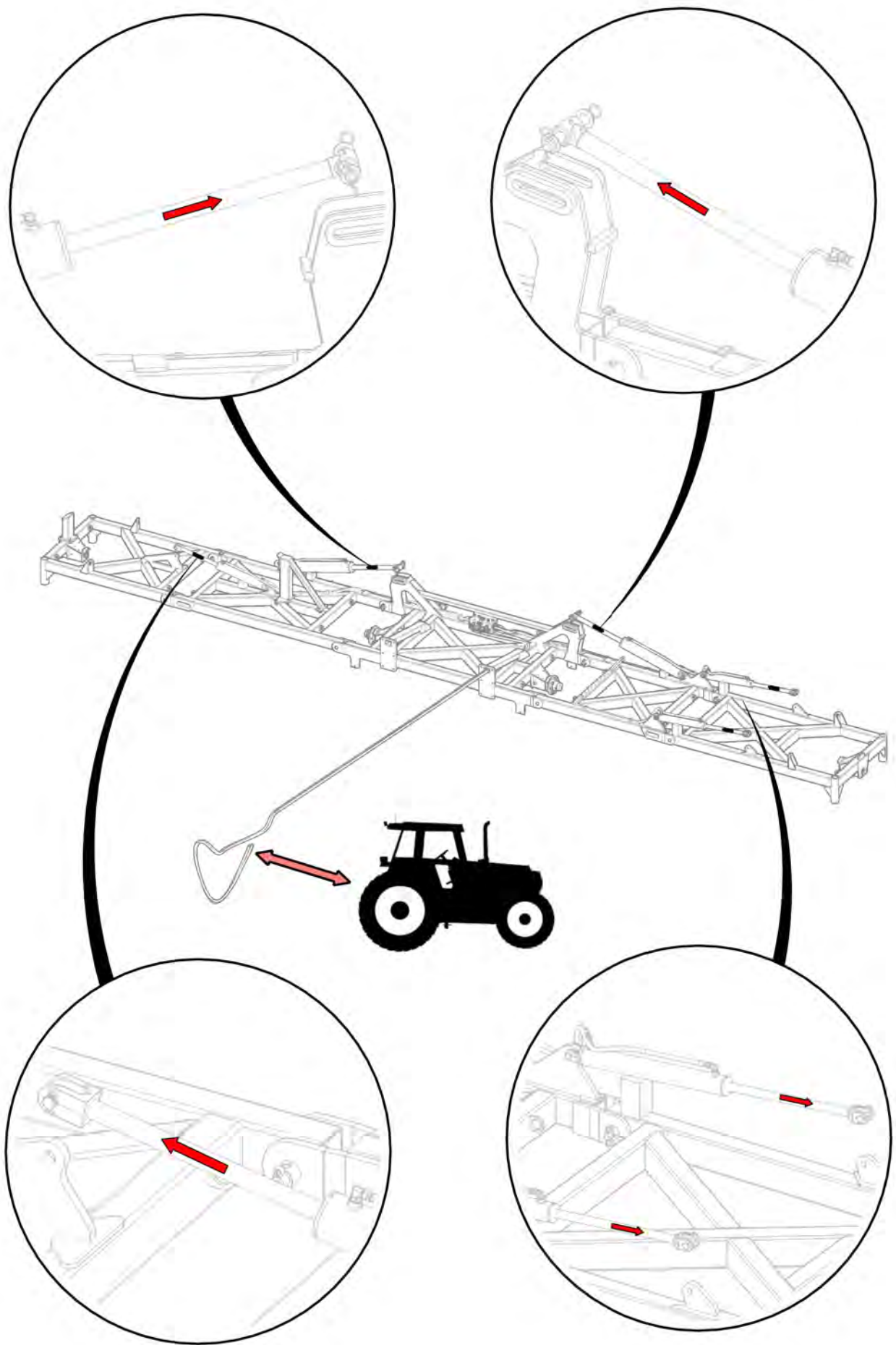



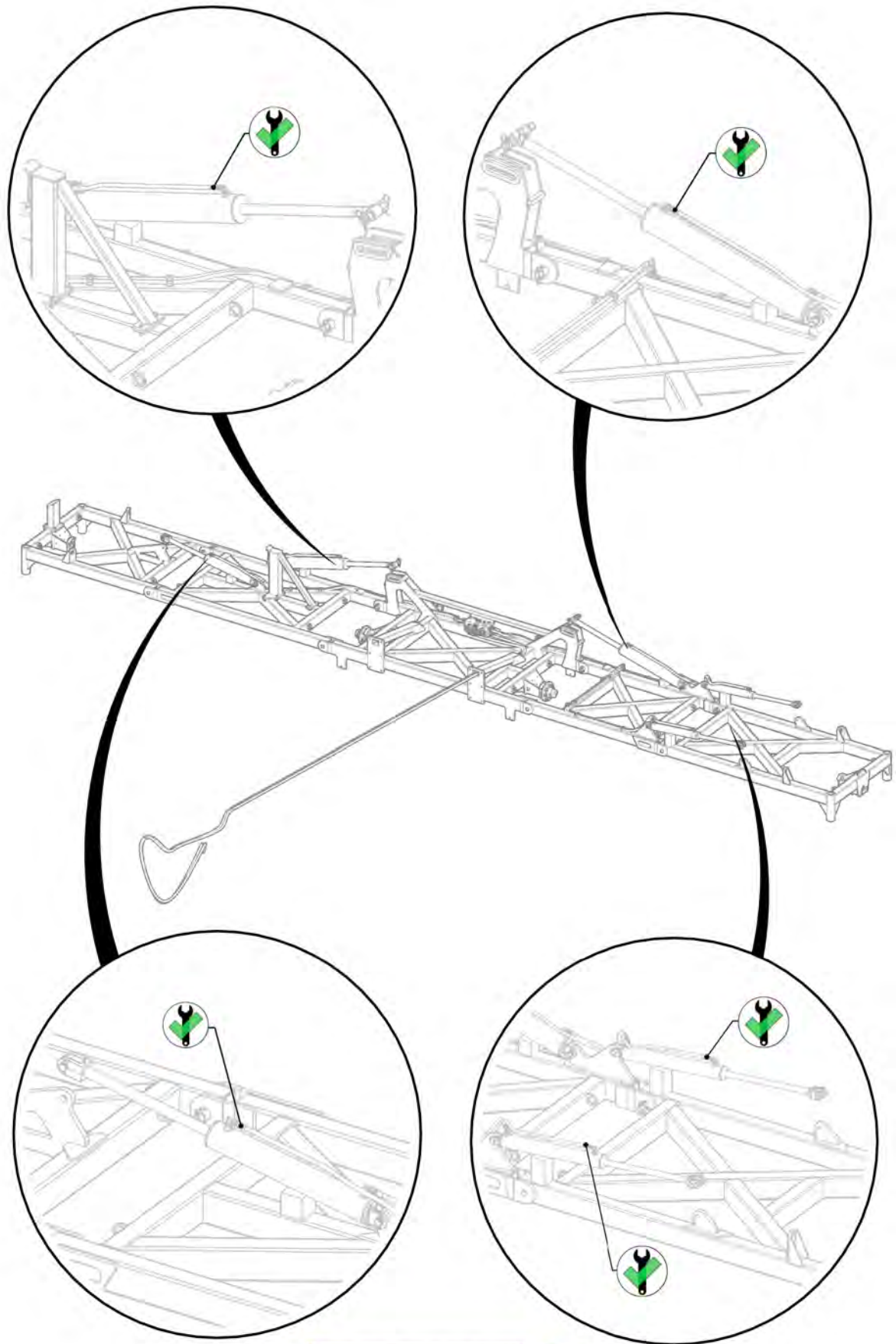

Retract fittings tightened

Signed \_\_\_\_\_ Date \_\_\_\_/\_\_\_\_/\_\_\_\_  
Unit Serial Number: \_\_\_\_\_

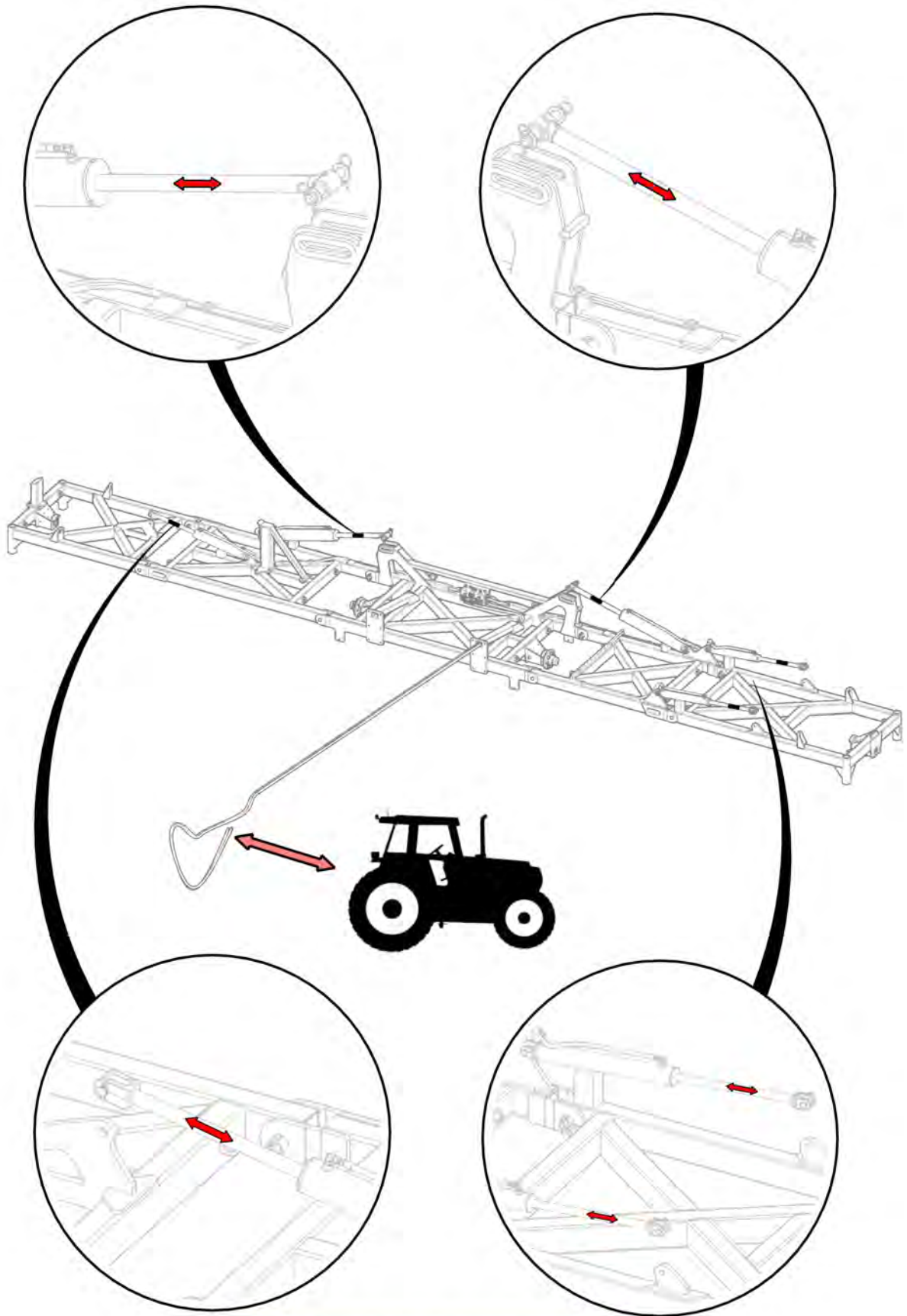

Cylinders cycled to expel air from system

Signed \_\_\_\_\_ Date \_\_\_\_/\_\_\_\_/\_\_\_\_  
 Unit Serial Number: \_\_\_\_\_

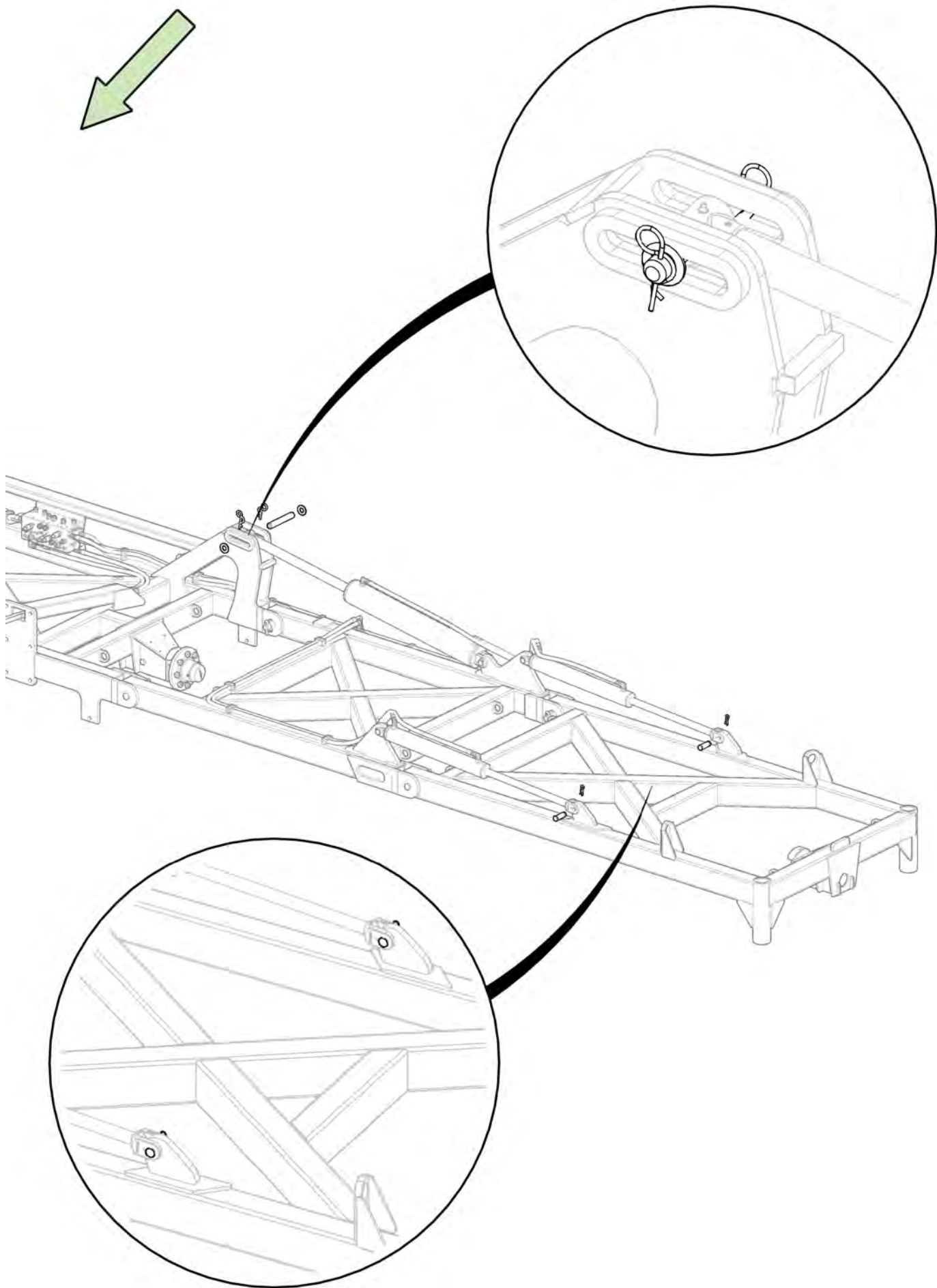

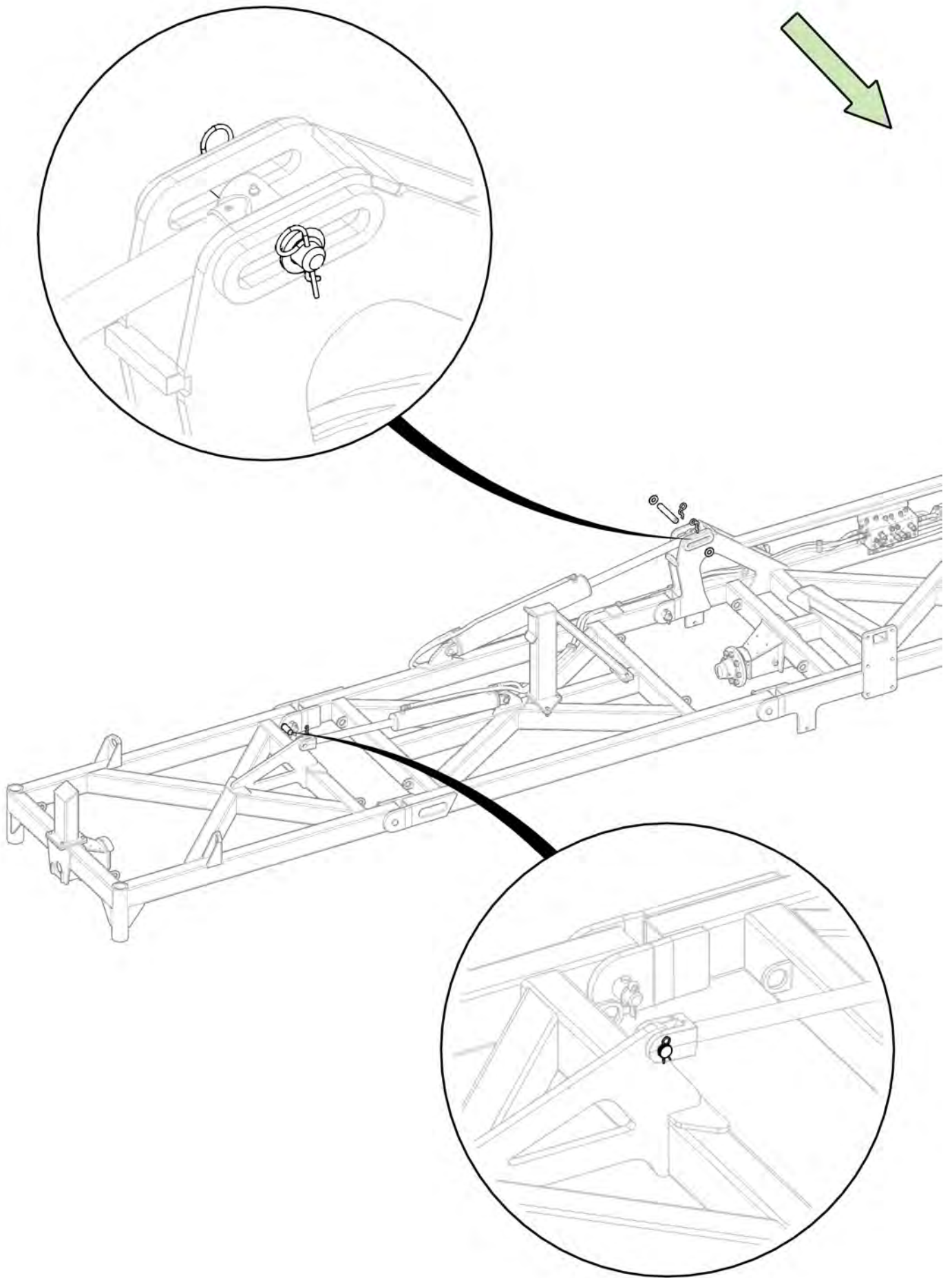



| Item No. | Description                | Number     | Qty |
|----------|----------------------------|------------|-----|
| 1        | 40' Front A Frame          | 0840-02    | 1   |
| 2        | M24 x 75 grade 8.8 zp Bolt | 0211-2475  | 12  |
| 3        | Nyloc Nut M24              | 0221-NYL24 | 12  |

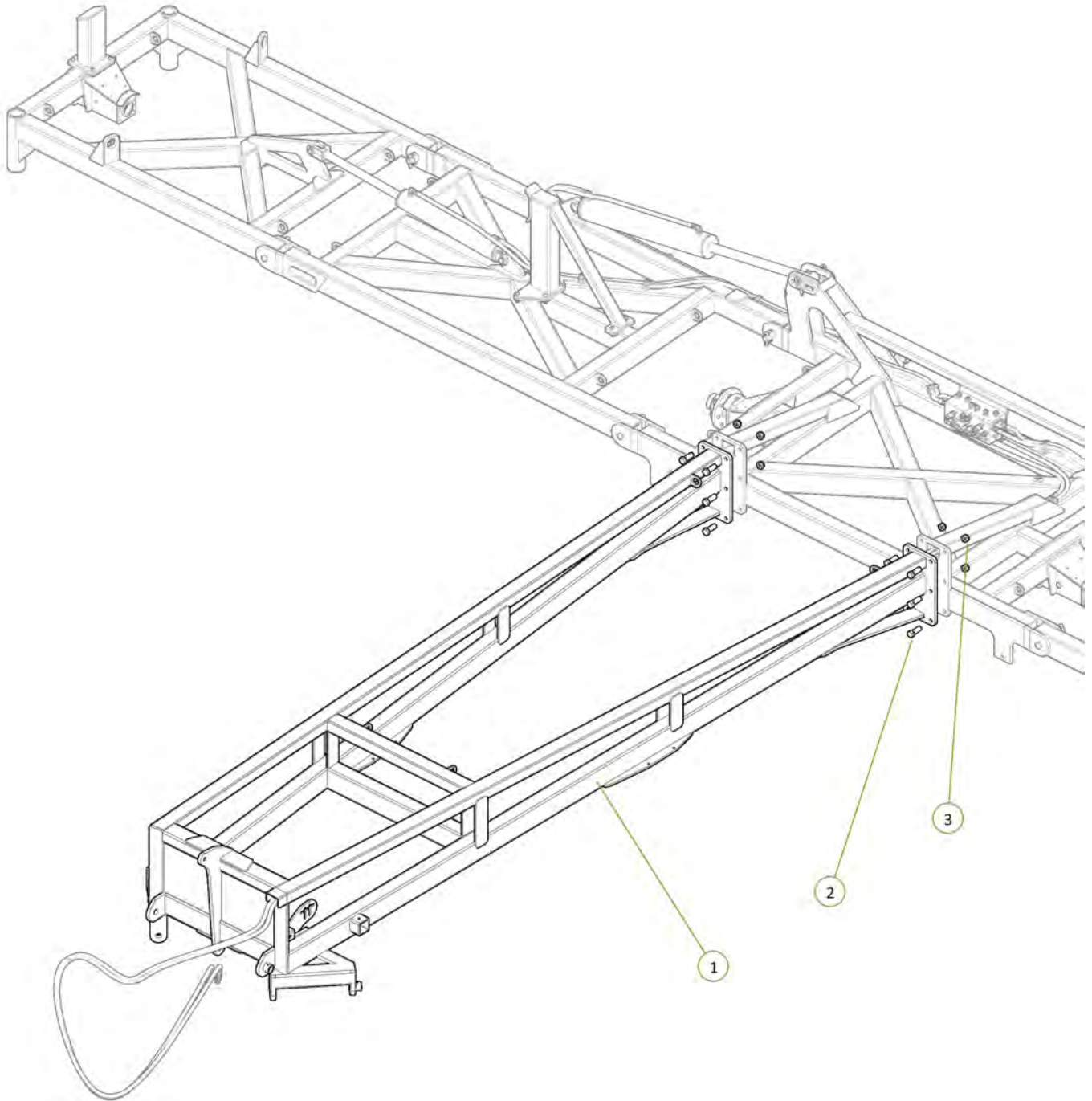

| Item No. | Description                                    | Number          | Qty |
|----------|--|-----------------|-----|
| 1        | 2.75"R 6 Tonne 8 on 8" PCD Hub & Stub Complete | 0733-SH27596880 | 1   |
| 2        | M20 x 170 grade 8.8 ZP Bolt                    | 0211-20170      | 1   |
| 3        | Nyloc Nut M20                                  | 0221-NYL20      | 1   |

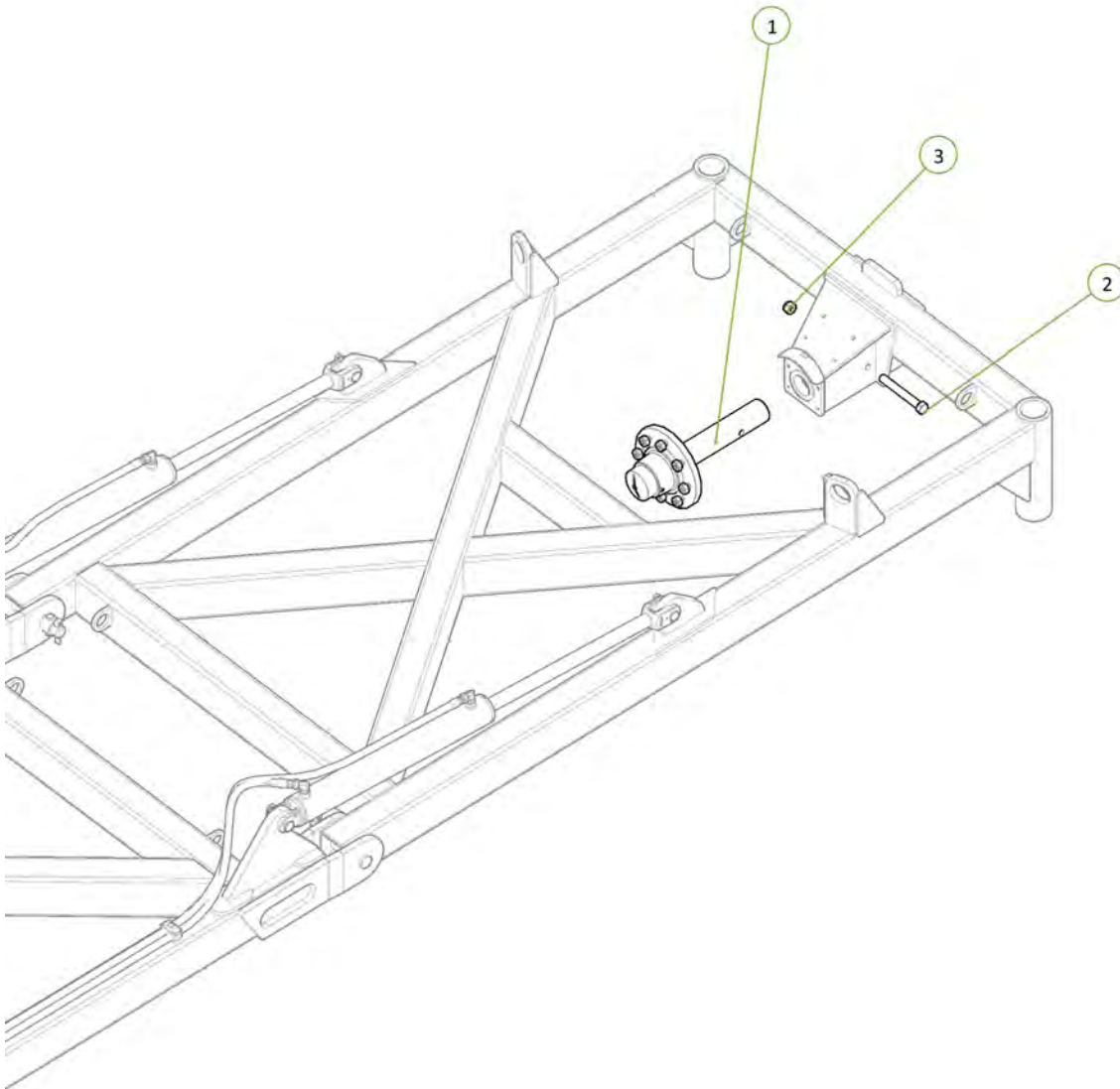
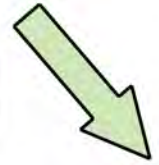

| Item No. | Description                                    | Number          | Qty |
|----------|--|-----------------|-----|
| 1        | 2.75"R 6 Tonne 8 on 8" PCD Hub & Stub Complete | 0733-SH27596880 | 1   |
| 2        | M20 x 170 grade 8.8 ZP Bolt                    | 0211-20170      | 1   |
| 3        | Nyloc Nut M20                                  | 0221-NYL20      | 1   |

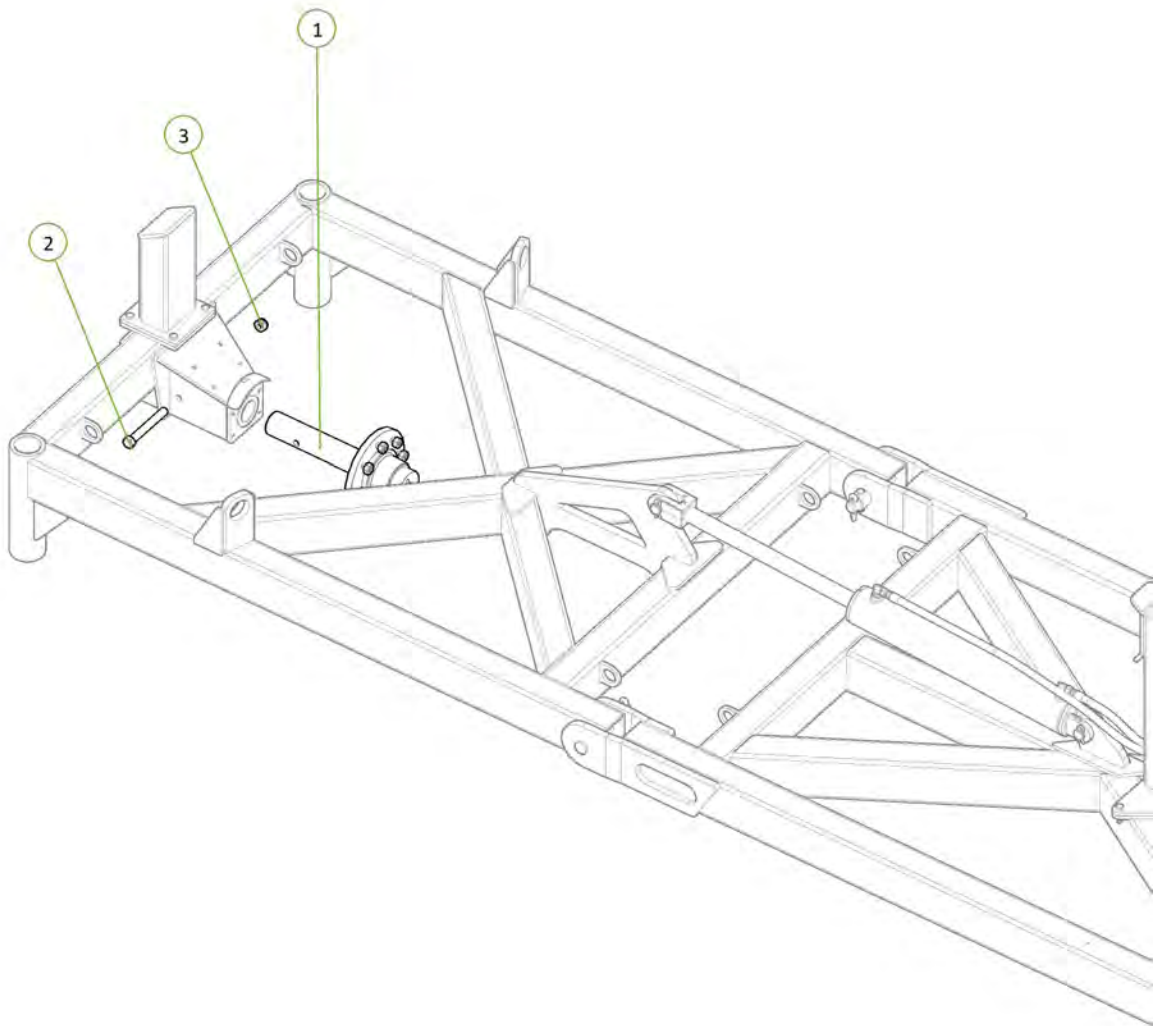

| Item No. | Description                        | Number            | Qty |
|----------|------------------------------------|-------------------|-----|
| 1        | 15.0/70-18 Tyre On 8 on 8" PCD Rim | 0751-15.0-70-18TR | 4   |

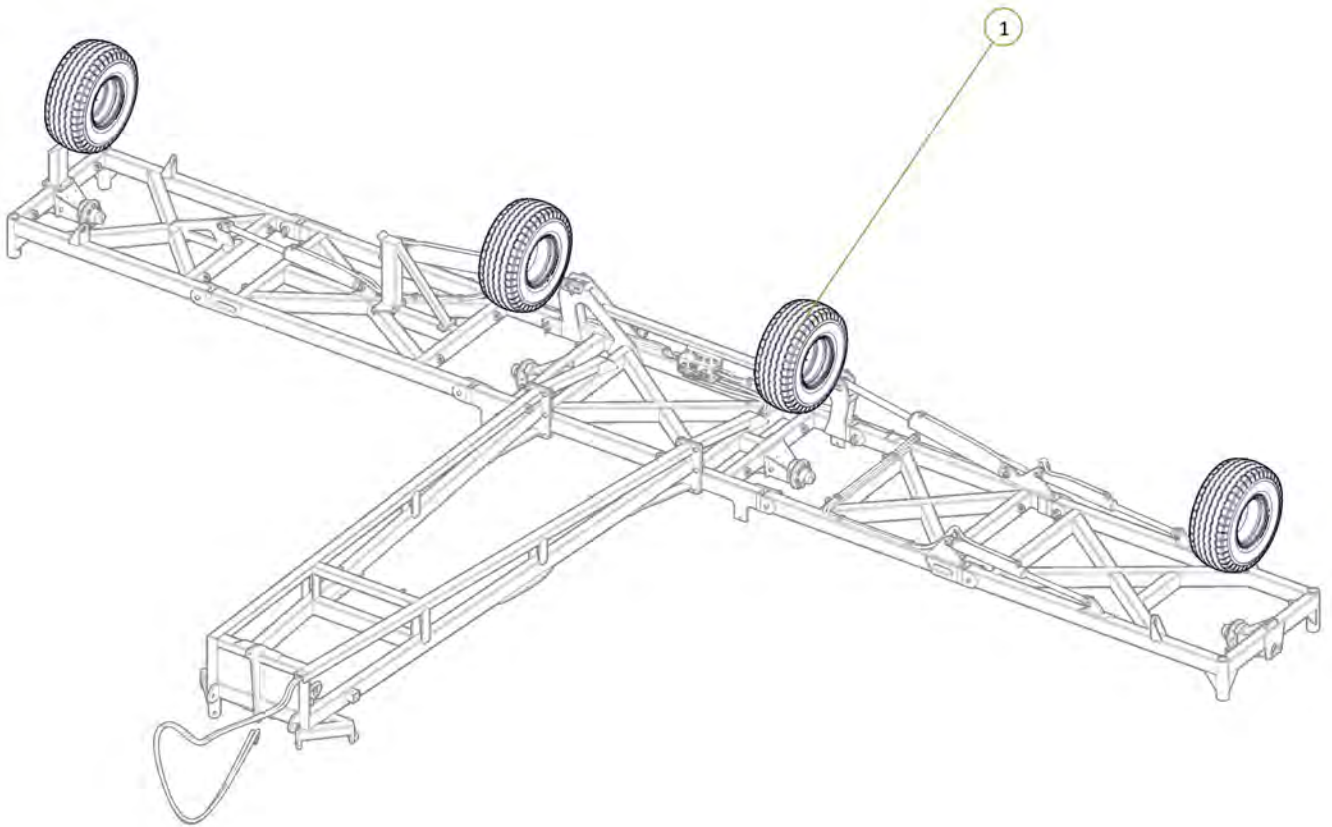

All wheel nuts tightened to 100ft-lb / 140Nm 

Signed \_\_\_\_\_ Date \_\_\_/\_\_\_/\_\_\_  
 Unit Serial Number: \_\_\_\_\_



| Item No. | Description                | Number         | Qty |
|----------|----------------------------|----------------|-----|
| 1        | T-Bar Drawbar              | 1510-08        | 1   |
| 2        | Drawbar Pivot Pin          | 0801-10-13-970 | 1   |
| 3        | Drawbar Pivot Bush         | 0801-B423838   | 4   |
| 4        | M12 x 65 grade 8.8 ZP Bolt | 0211-1265      | 1   |
| 5        | Nyloc Nut M12              | 0221-NYL12     | 1   |
| 6        | Cotter Pin M13 x 63        | 0261-PINC1363  | 1   |

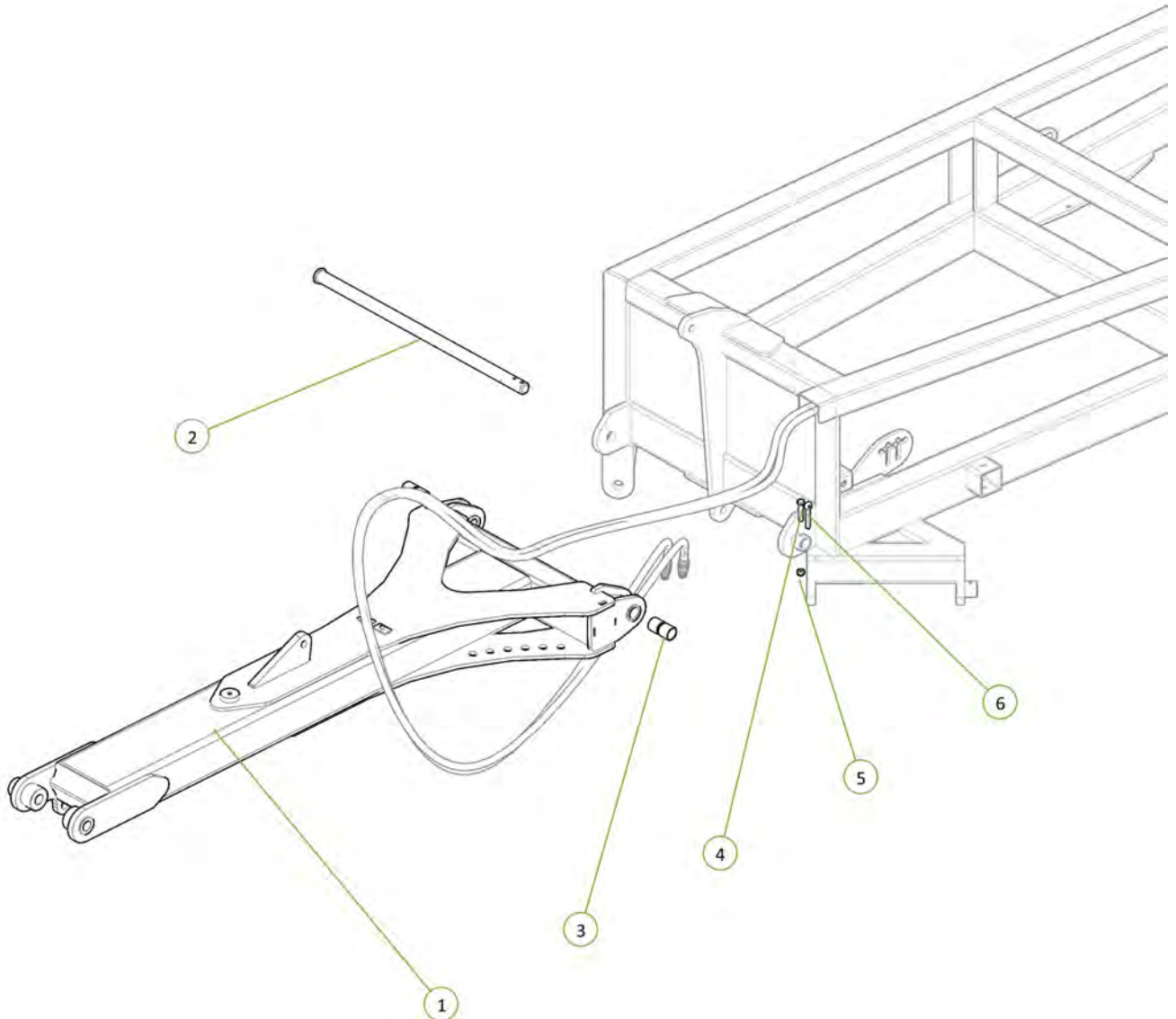
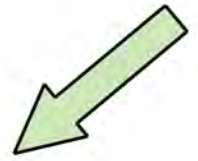

| Item No. | Description                    | Number           | Qty |
|----------|--------------------------------|------------------|-----|
| 1        | Tow Hitch                      | 0810-09          | 1   |
| 2        | Drawbar Tow Hitch Pin          | 1601-P35-370     | 1   |
| 3        | M12 x 75 grade 8.8 ZP Bolt     | 0211-1275        | 1   |
| 4        | Nyloc Nut M12                  | 0221-NYL12       | 1   |
| 5        | Cotter Pin M13 x 63            | 0261-PINC1363    | 1   |
| 6        | Hardened Tow Hitch Bush 2 1/4" | 0801-KE-0905-1-B | 1   |
| 7        | Criclip External 82mm          | 0172-D1400-0820  | 1   |

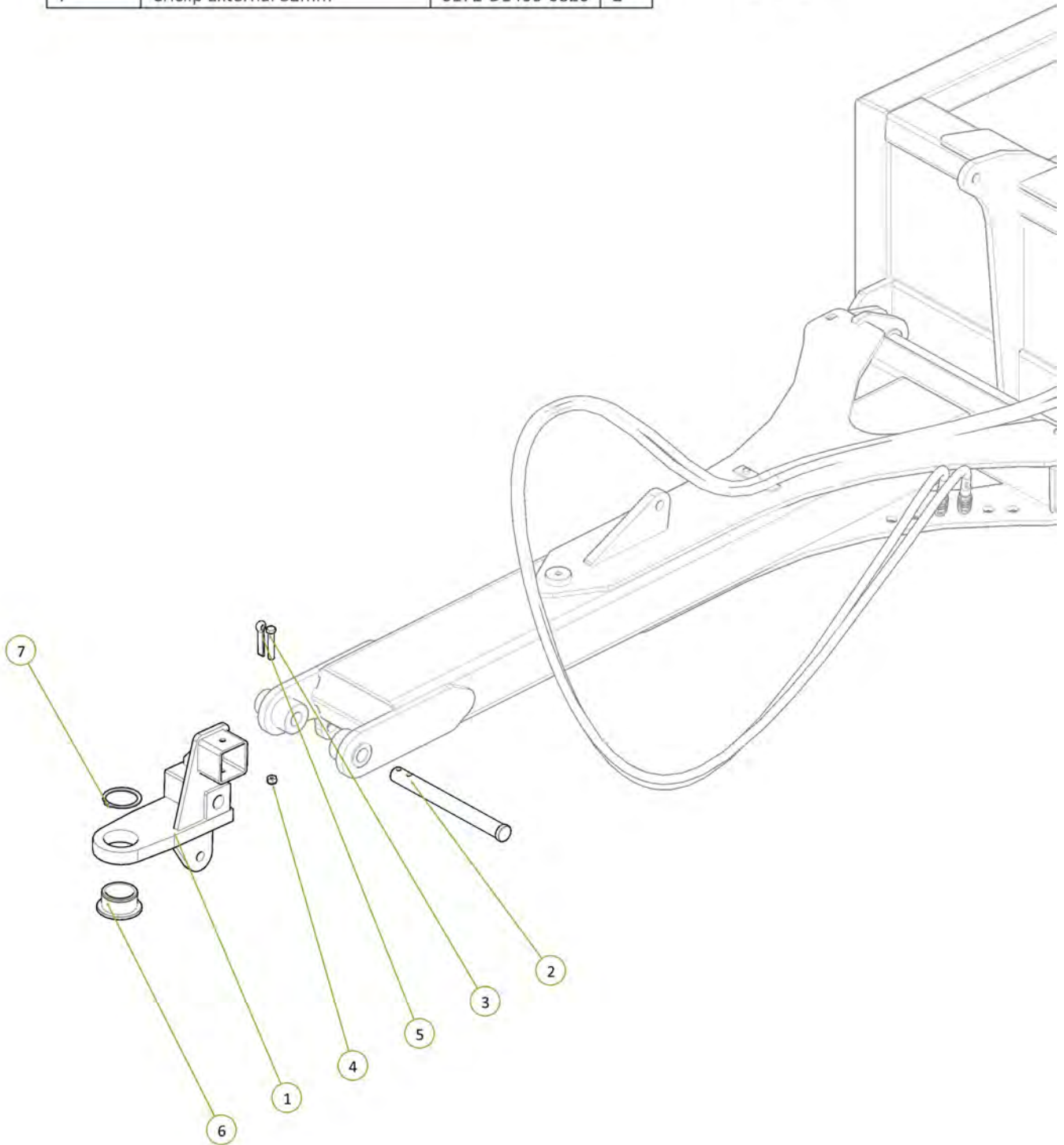
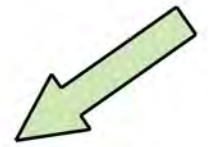

| Item No. | Description            | Number        | Qty |
|----------|------------------------|---------------|-----|
| 1        | Parallel Arm           | 0810-22       | 1   |
| 2        | Clevis Pin 25mm x 75mm | 0801-KE0307-1 | 2   |
| 3        | Washer Flat M24        | 0231-F24      | 2   |
| 4        | Cotter Pin M6 x 50mm   | 0261-PINC650  | 2   |

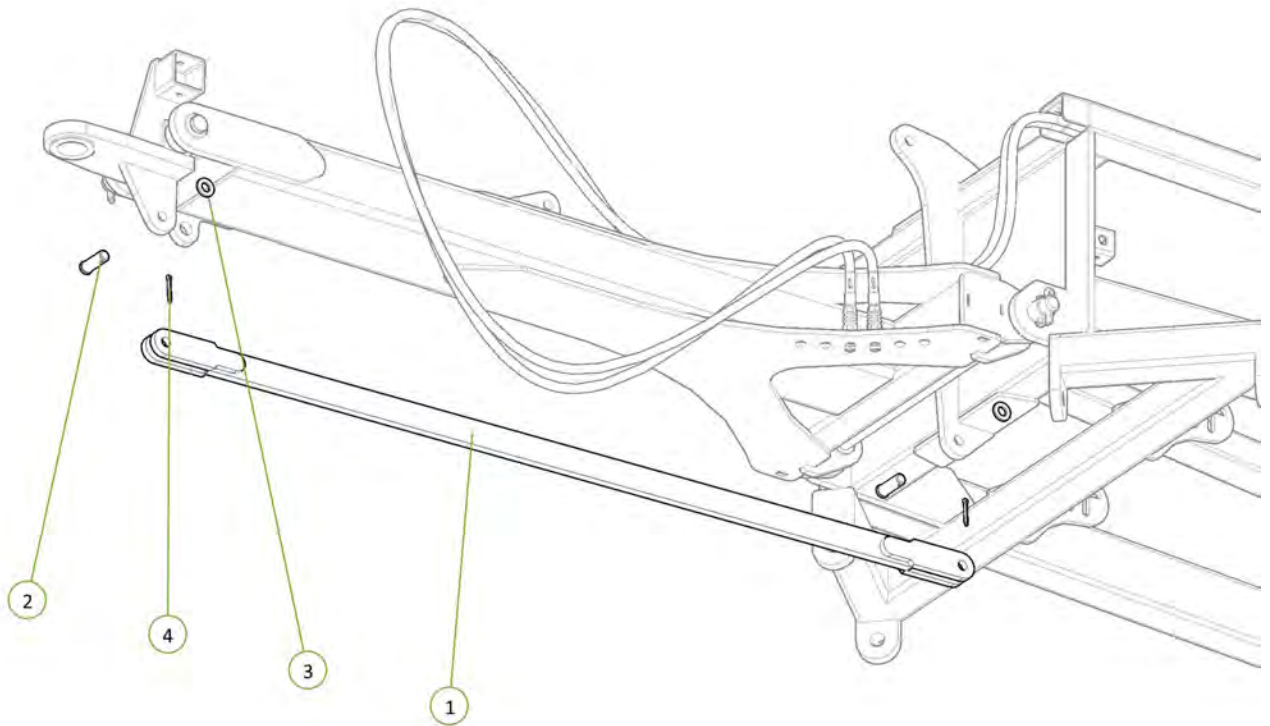
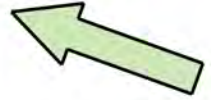

| Item No. | Description   | Number      | Qty |
|----------|---|-------------|-----|
| 1        | 3" Bore x 12" Stroke 1.5" Rod Extended Hydraulic Cylinder | 0311-312EXT | 1   |

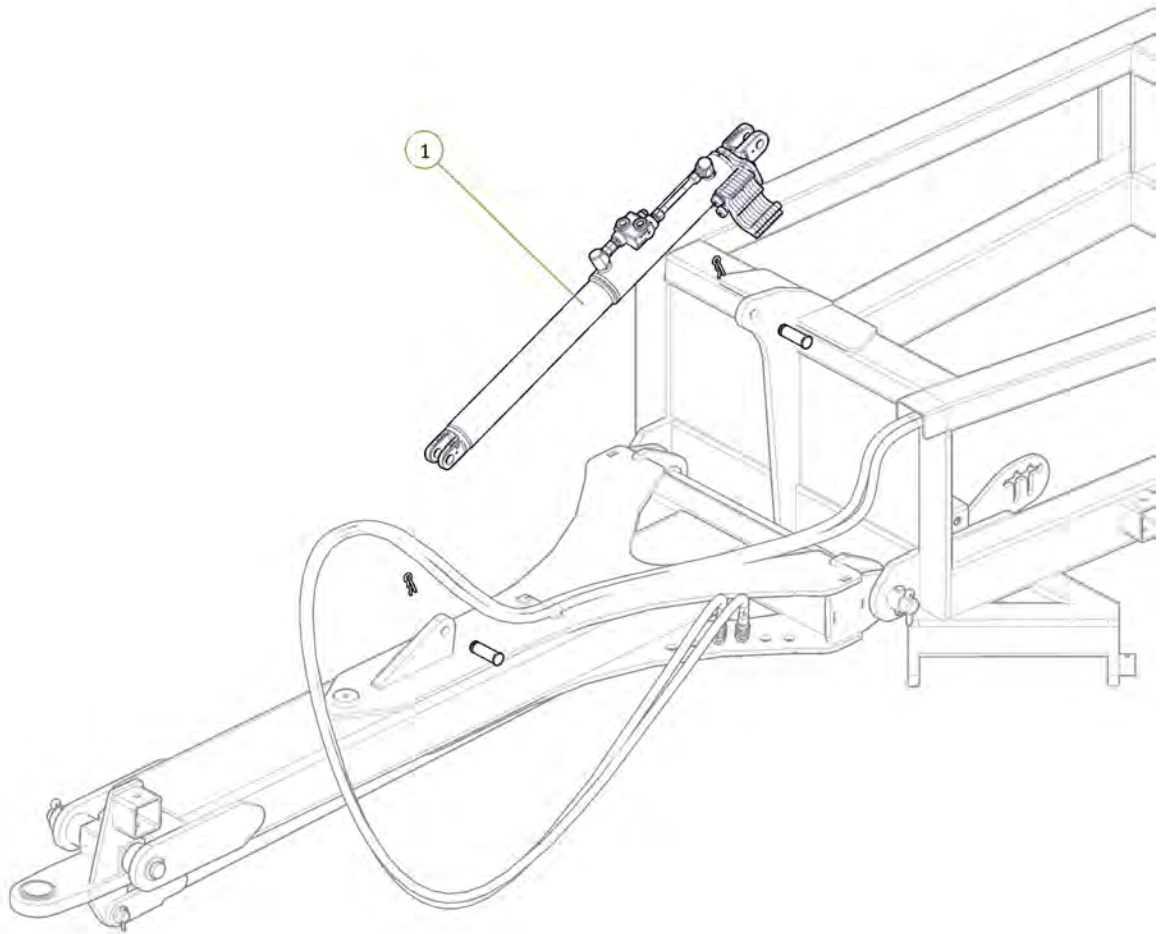
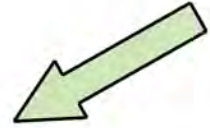



| Item No. | Description   | Number      | Qty |
|----------|---------------|-------------|-----|
| 1        | Jack Assembly | 0801-SAK45B | 1   |
| 2        | Jack Pin      | 0801-B3077  | 1   |

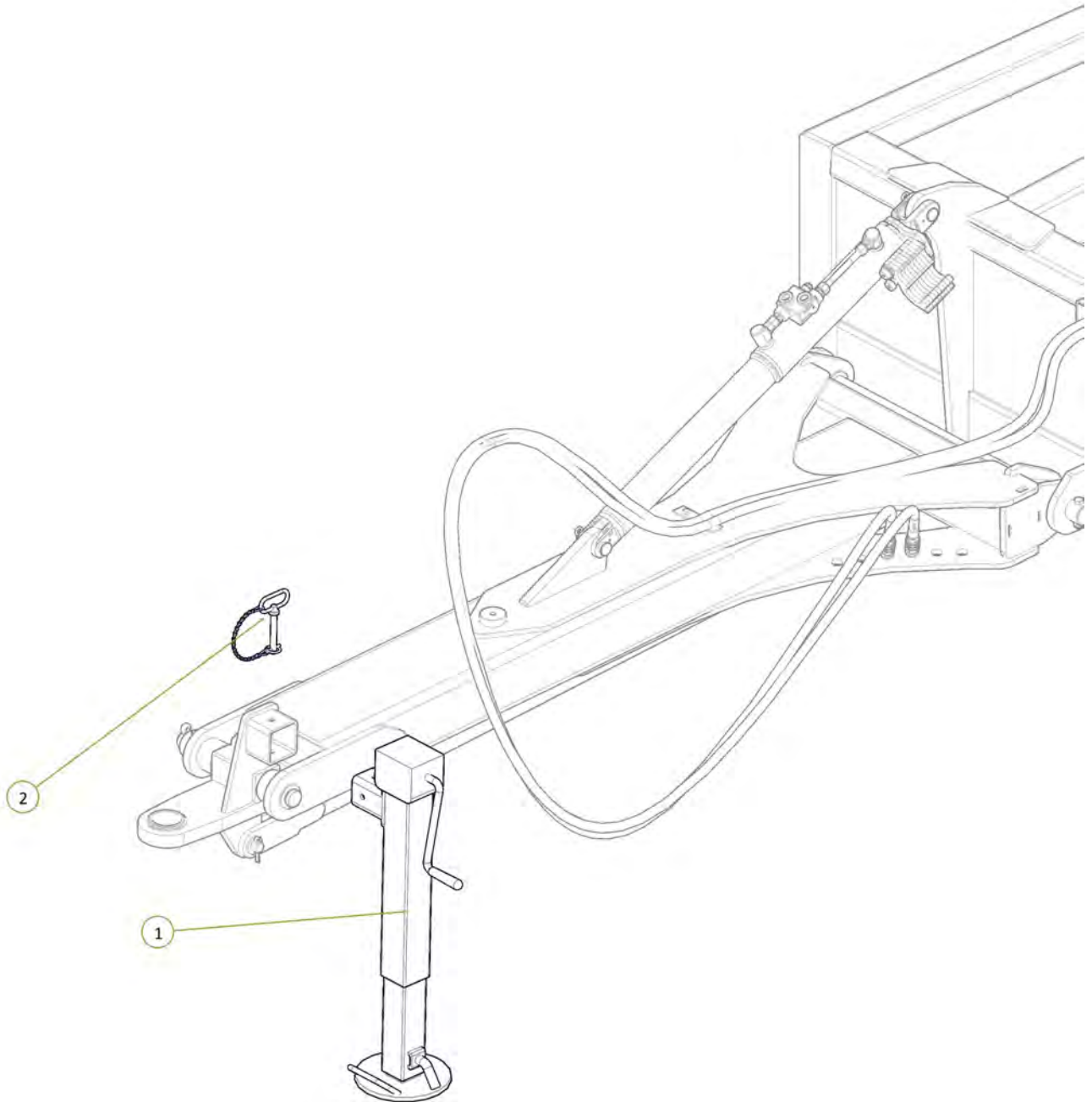
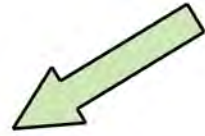

| Item No. | Description                | Number           | Qty |
|----------|----------------------------|------------------|-----|
| 1        | Hose Post Spring           | 1601-CDB-00-0012 | 1   |
| 2        | M16 x 35 grade 8.8 zp Bolt | 0211-1635        | 1   |
| 3        | Washer Spring M16          | 0231-S16         | 1   |
| 4        | Washer Flat M16            | 0231-F16         | 1   |

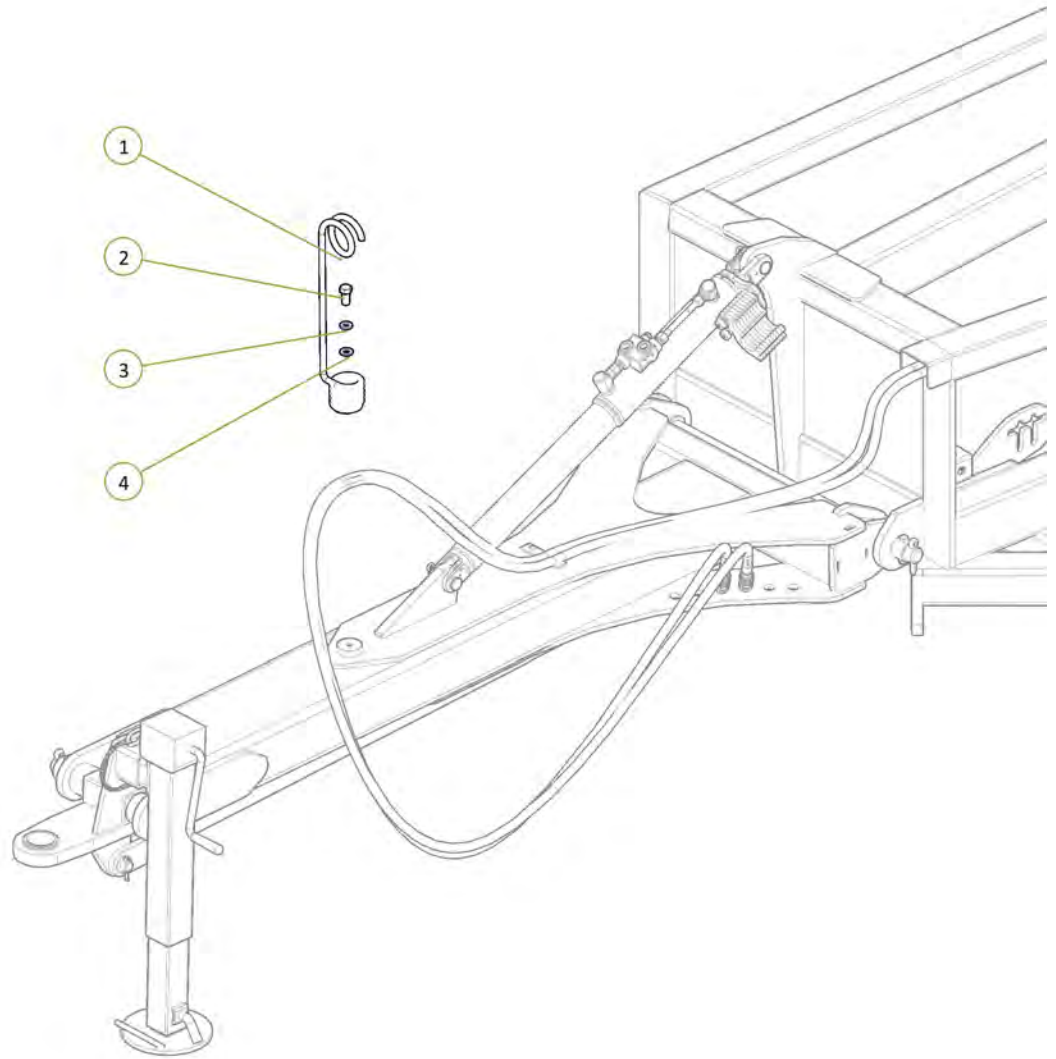
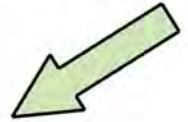

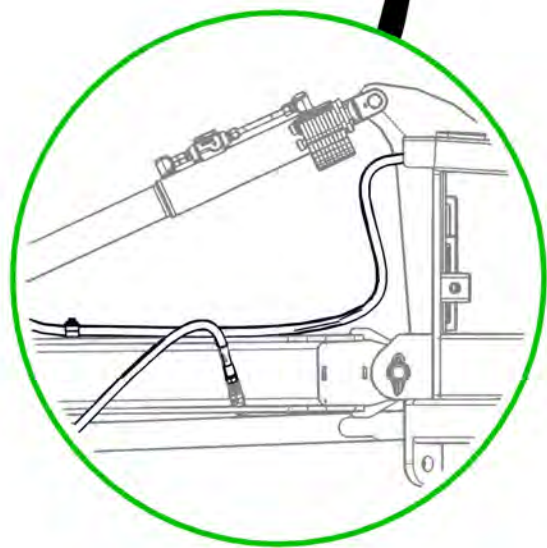
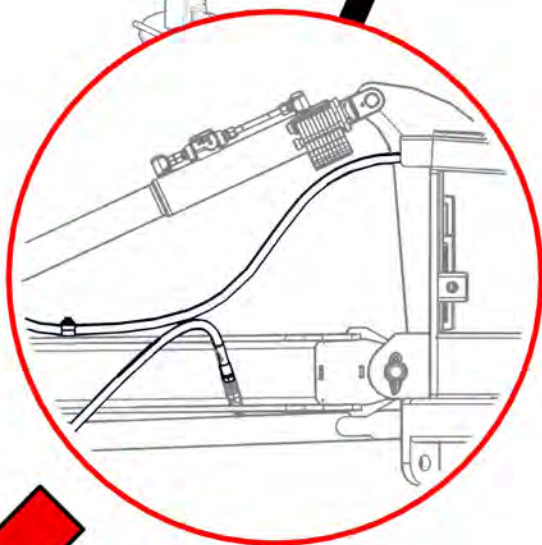
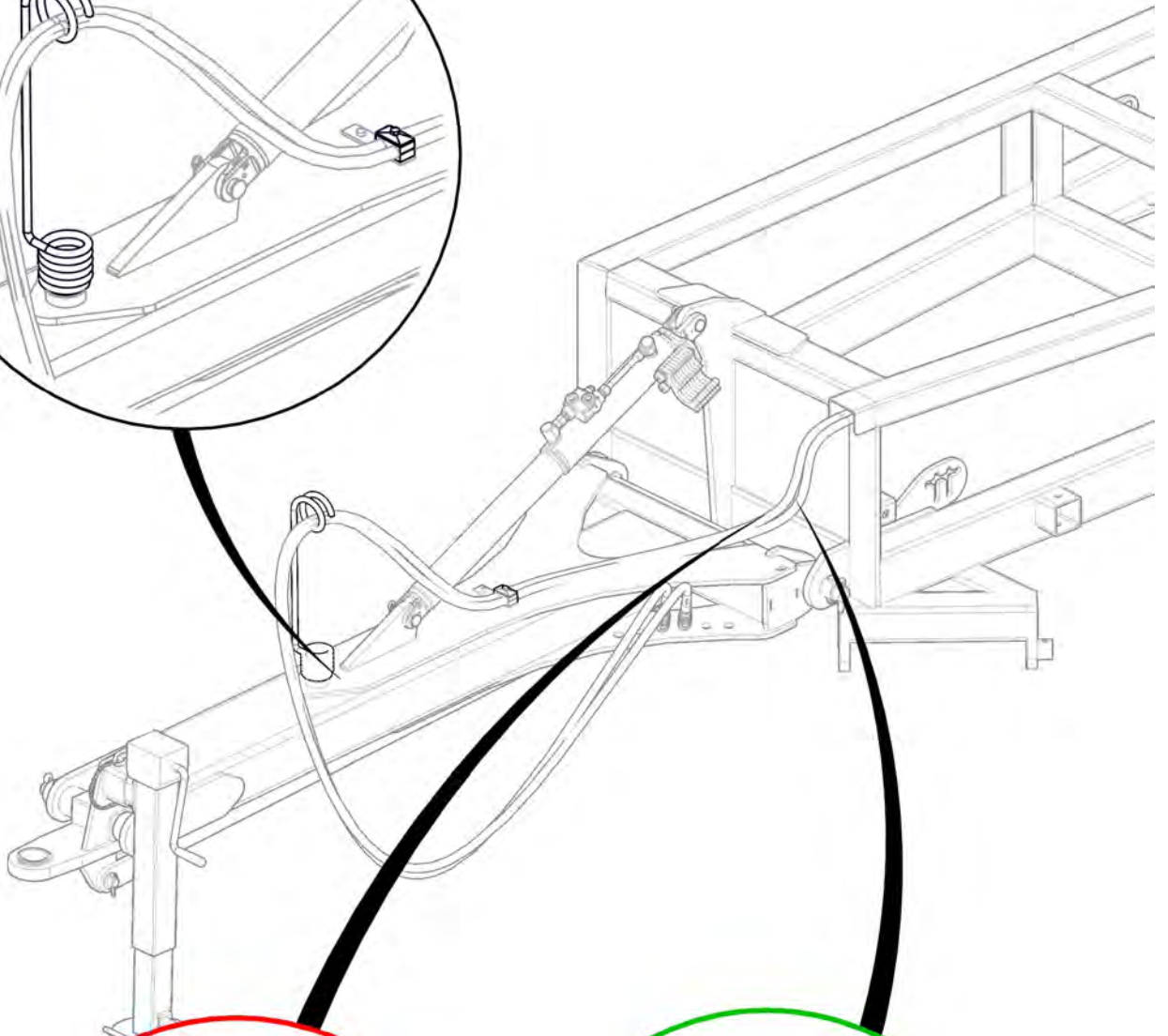
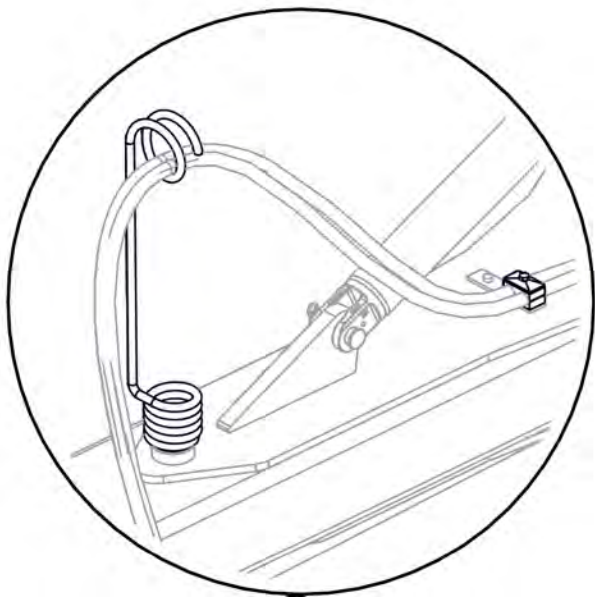



| Item No. | Description  | Number          | Qty |
|----------|--|-----------------|-----|
| 1        | Tractor to Sequence Valve EXT2 Port Fitted with Yellow Extend Decal  | PH40-01-YE-EXT2 | 1   |
| 2        | Tractor to Sequence Valve RCT2 Port Fitted with Yellow Retract Decal | PH40-01-YR-RCT2 | 1   |

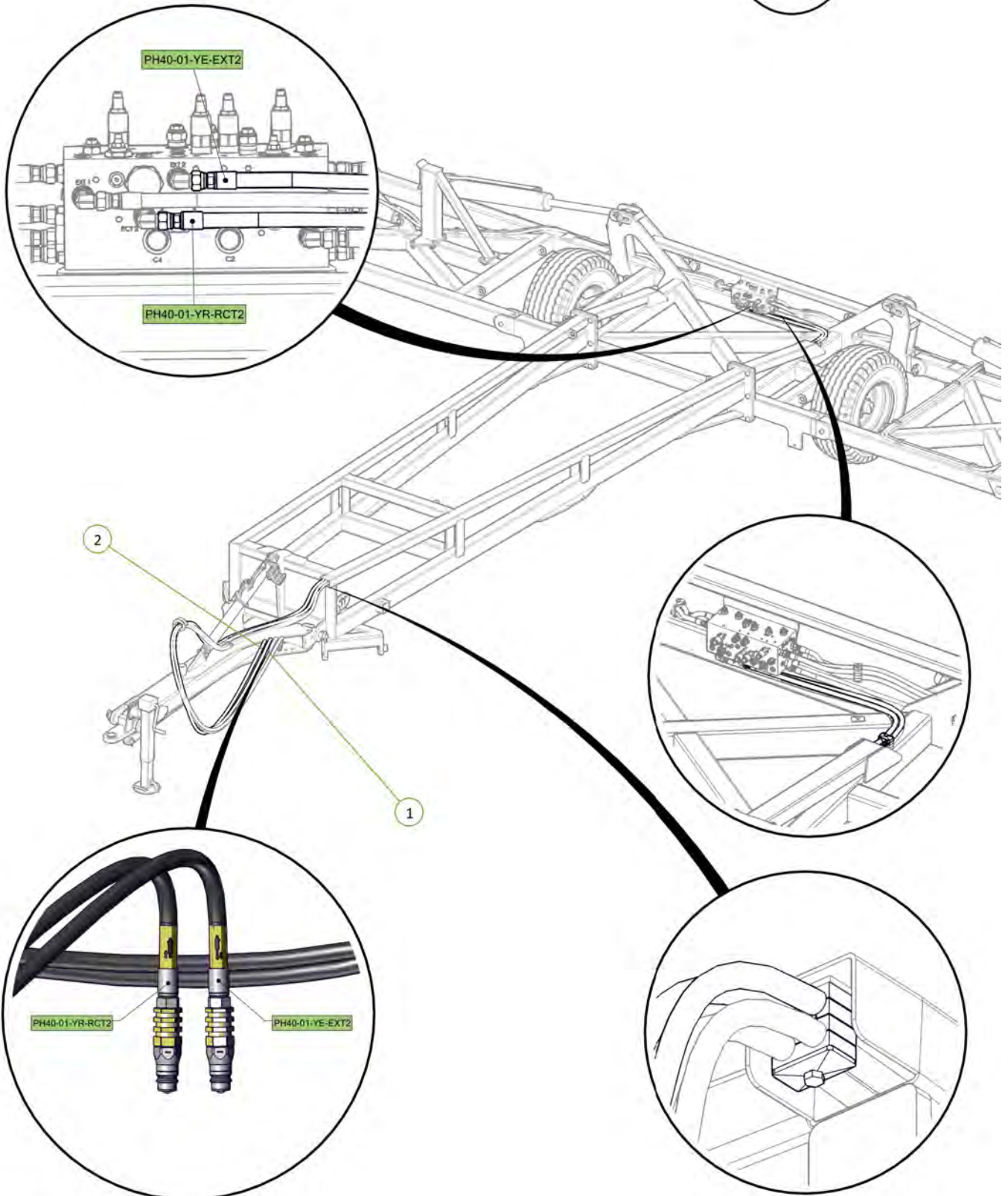
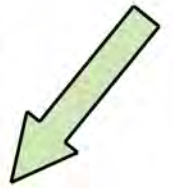



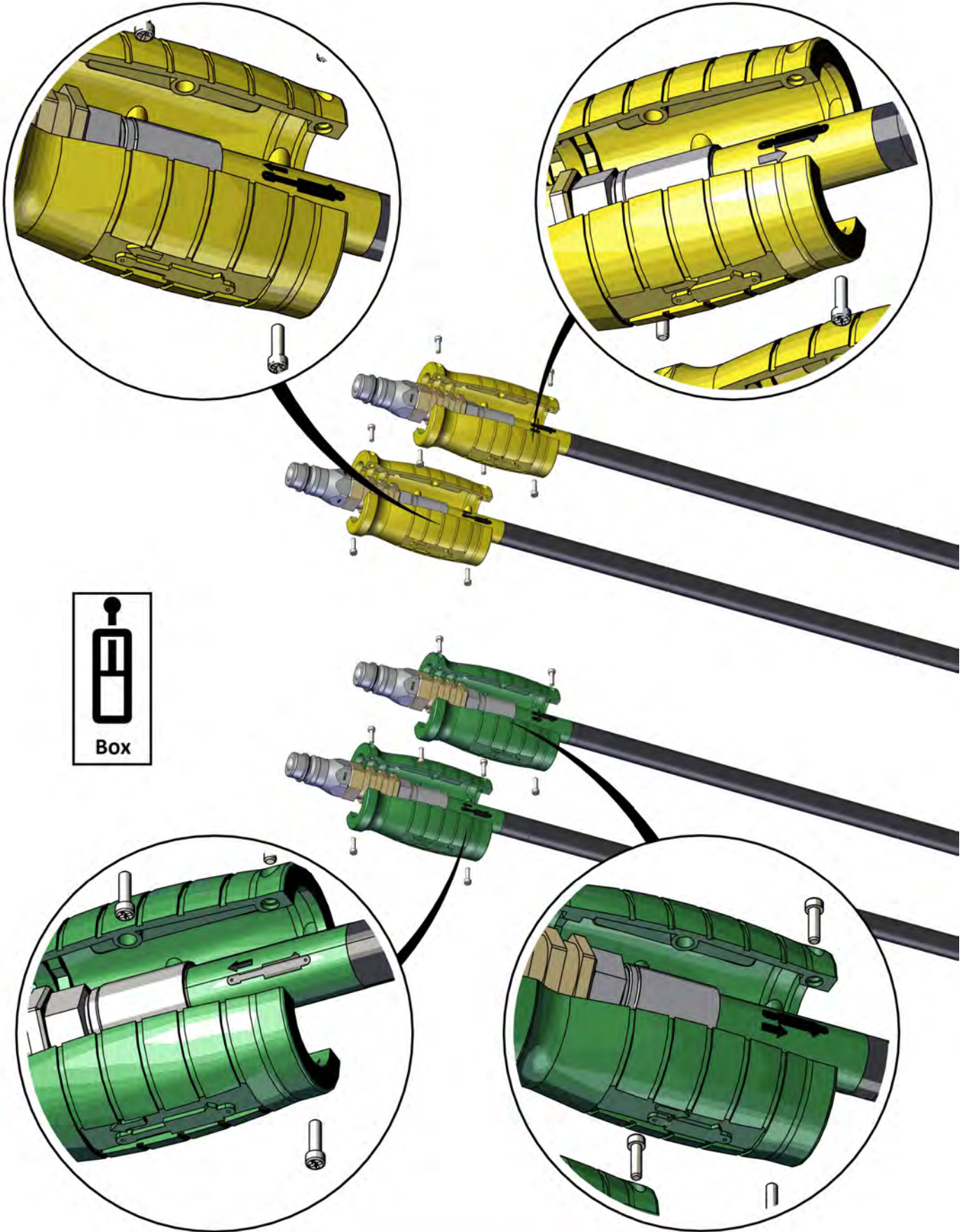

Hose grip handles fitted as per stickers on hoses



Signed \_\_\_\_\_ Date \_\_\_\_ / \_\_\_\_ / \_\_\_\_  
 Unit Serial Number \_\_\_\_\_

| Item No. | Description                                 | Number        | Qty |
|----------|---|---------------|-----|
| 1        | 3/4" JIC Male 3/4" UN O Ring Male 90° Elbow | 0323-S91-1212 | 2   |

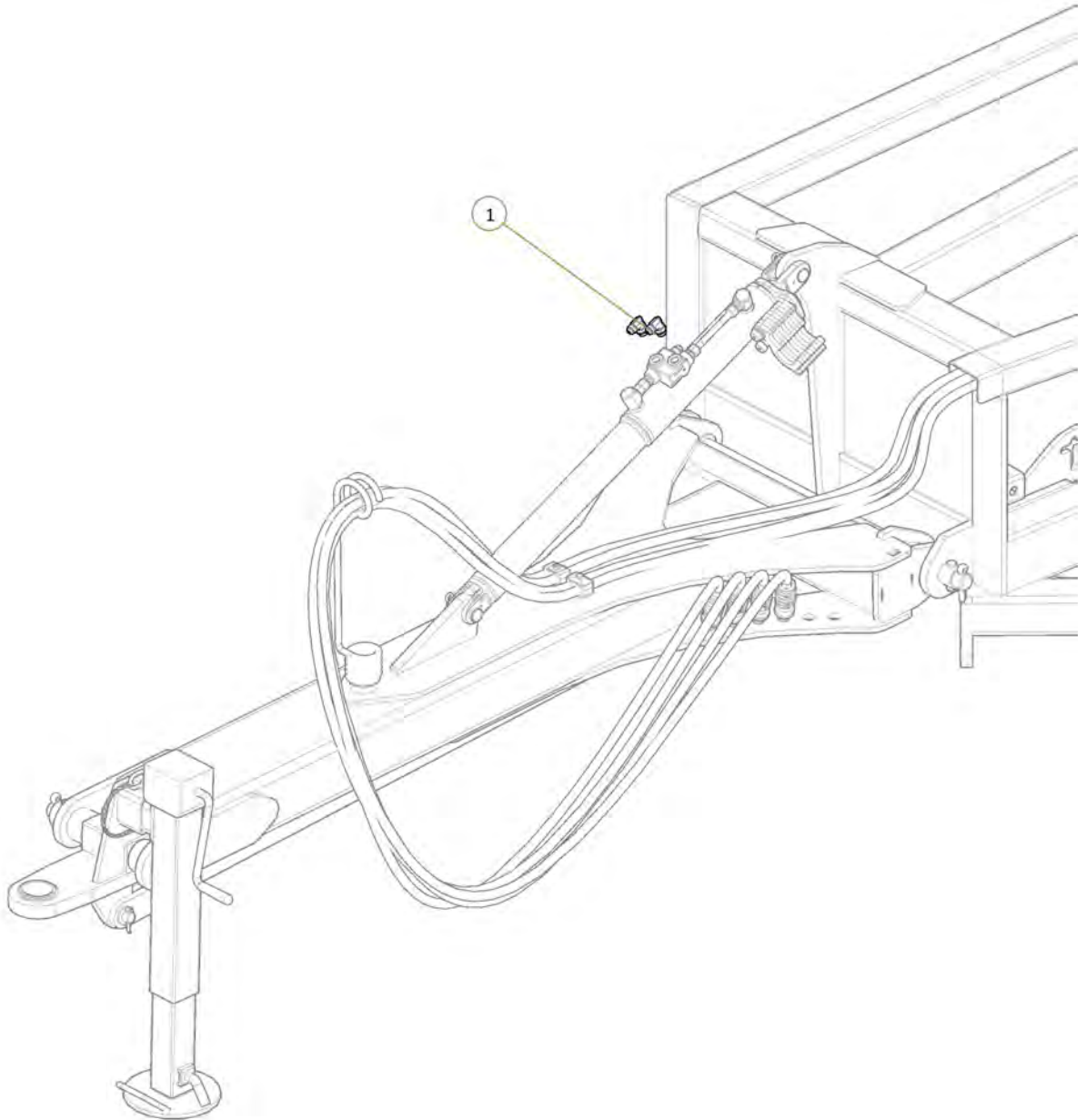
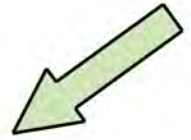



| Item No. | Description   | Number         | Qty |
|----------|---|----------------|-----|
| 1        | Tractor to Front lift Cylinder Extend Port Fitted with Blue Extend Grip   | PH40-02-BE-EXT | 1   |
| 2        | Tractor to Front Lift Cylinder Retract Port Fitted with Blue Retract Grip | PH40-03-BR-RCT | 1   |

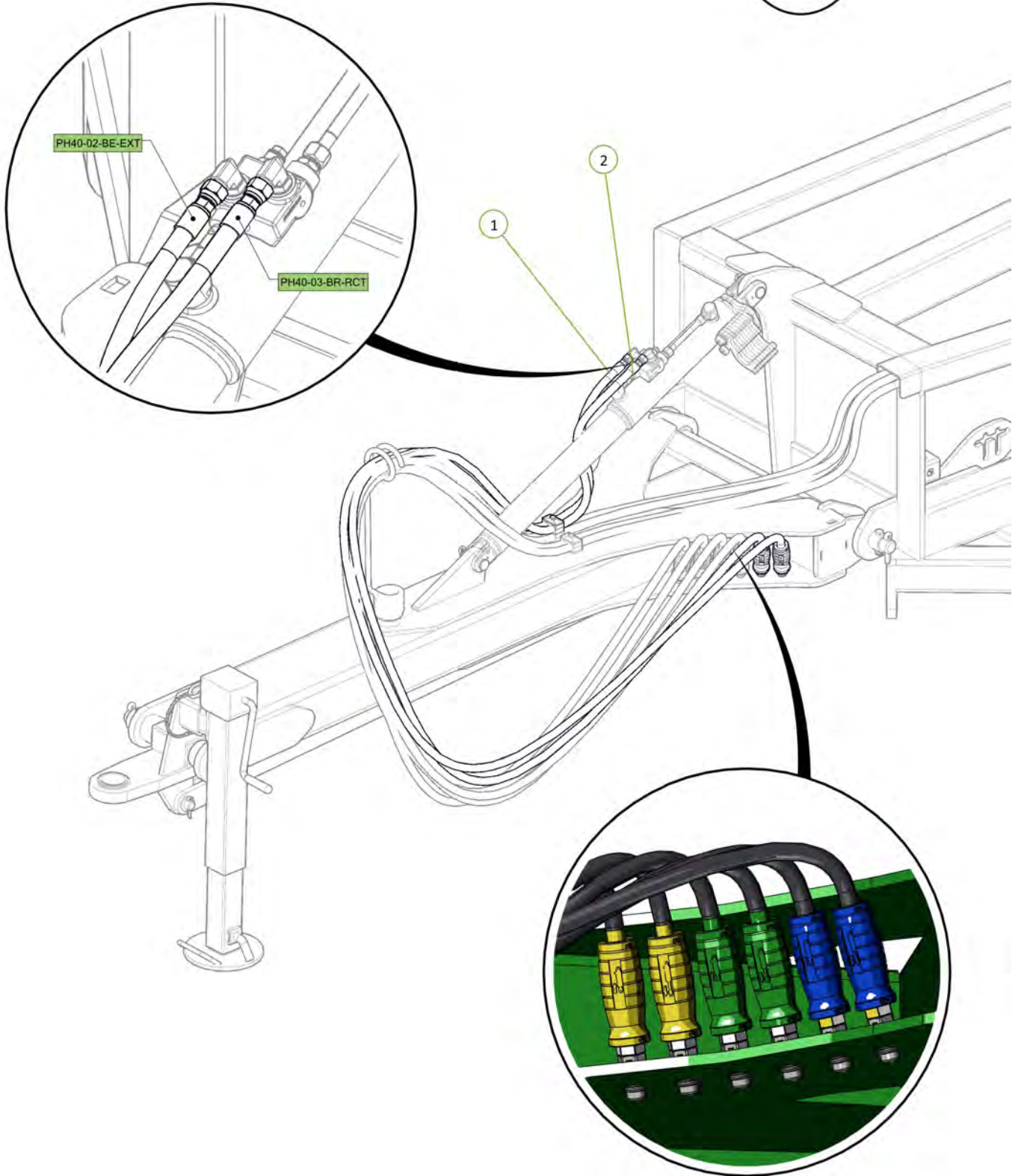

| Item No. | Description                | Number         | Qty |
|----------|----------------------------|----------------|-----|
| 1        | 40" Rear A Frame           | 0840-03        | 1   |
| 2        | Tail Frame Pivot pin       | 0801-10-08-175 | 2   |
| 3        | M12 x 65 grade 8.8 ZP Bolt | 0211-1265      | 2   |
| 4        | Nyloc Nut M12              | 0221-NYL12     | 2   |
| 5        | Cotter Pin M13 x 63        | 0261-PINC1363  | 2   |

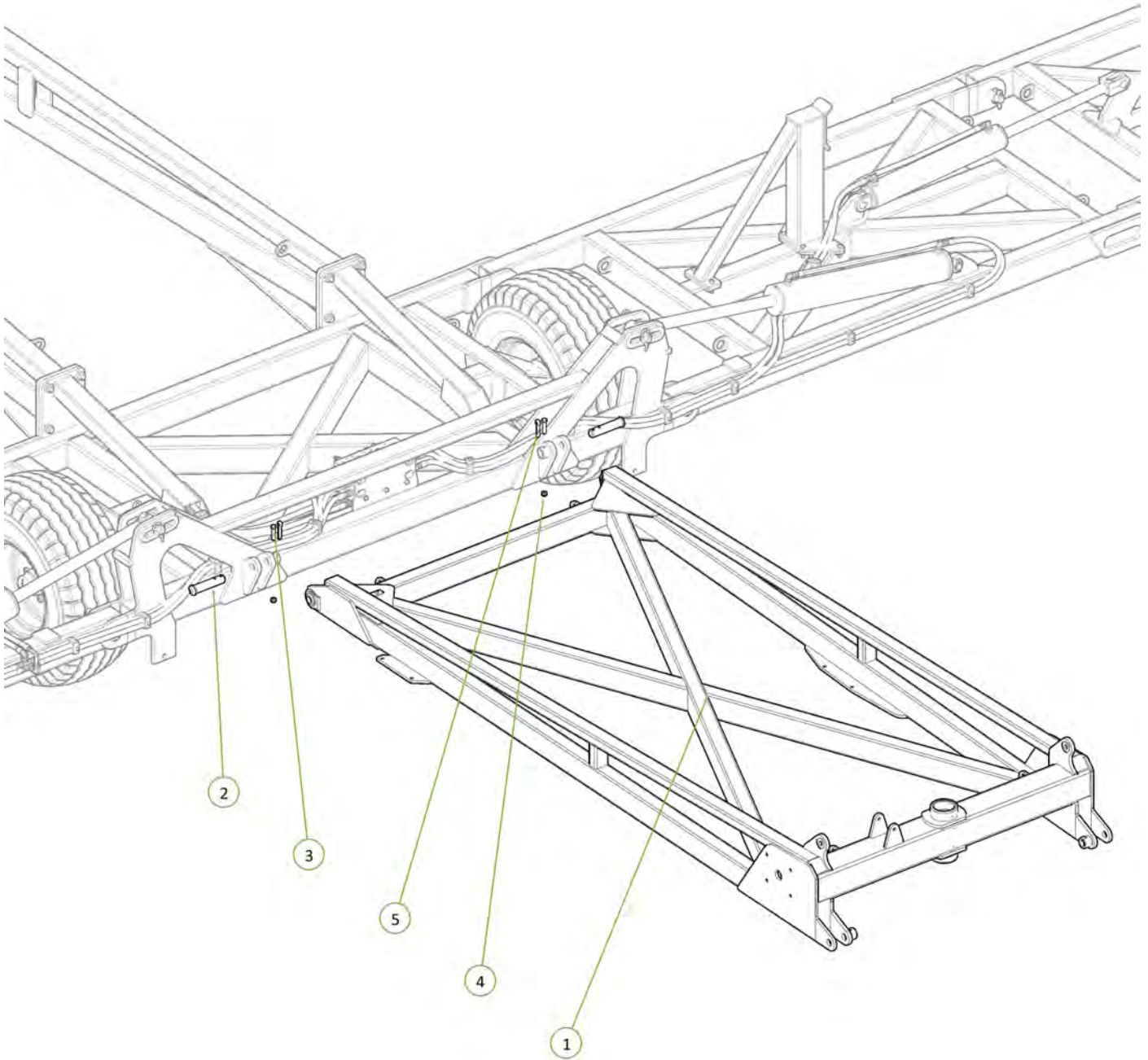



| Item No. | Description                  | Number          | Qty |
|----------|------------------------------|-----------------|-----|
| 1        | 70mm Jockey Wheel            | 0810-11-70      | 1   |
| 2        | Plain Spherical Bearing 70mm | 0113-GE70DO-2RS | 2   |
| 3        | Circlip Internal 105mm       | 0171-J105       | 2   |
| 4        | Circlip External 70mm        | 0172-D1400-70   | 1   |
| 5        | Grease Nipple 1/4" UNF       | 0181-GN1-4      | 2   |

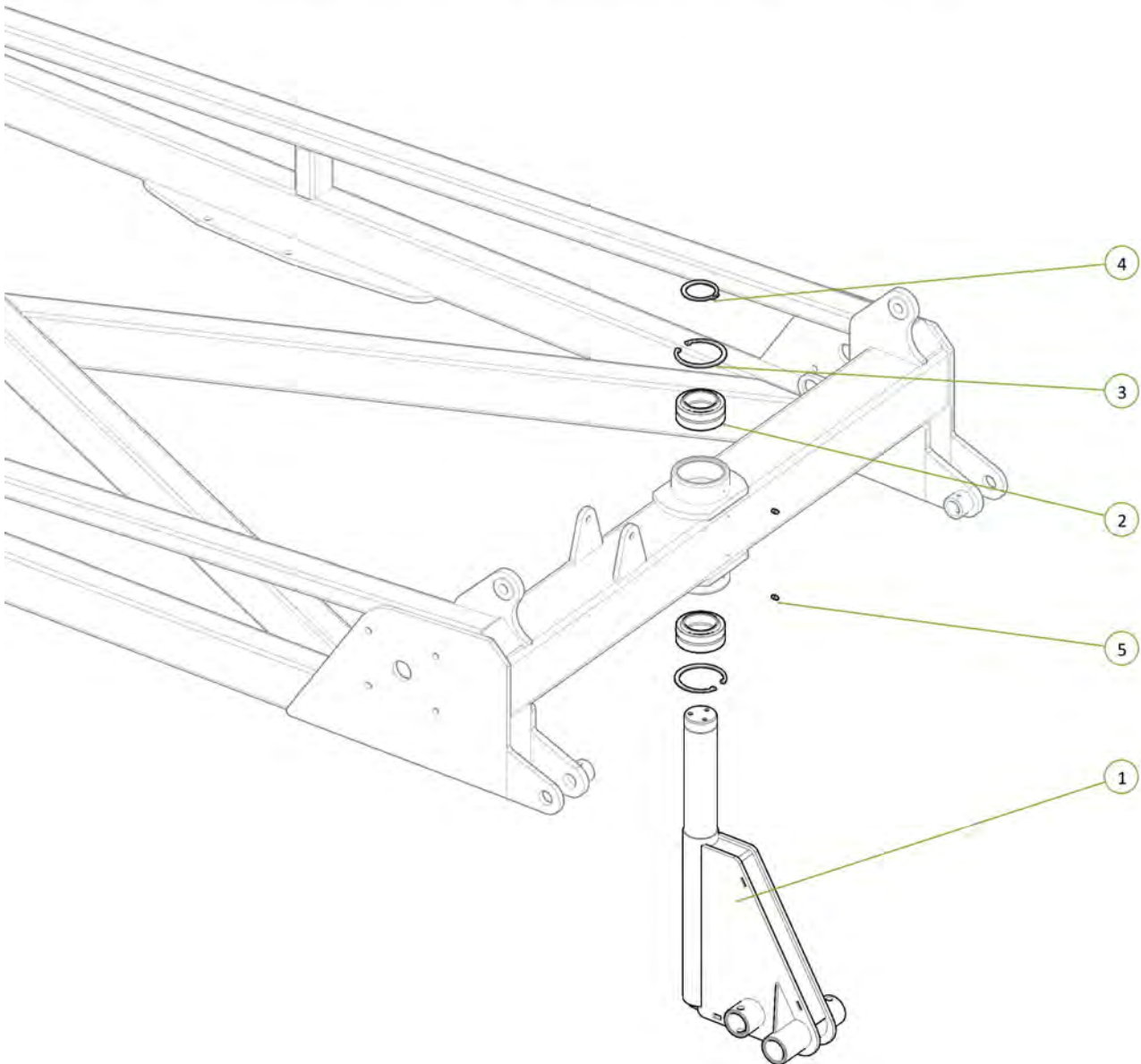
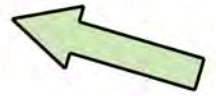



Circlip fitted to jockey Wheel shaft 

Signed \_\_\_\_\_ Date \_\_\_/\_\_\_/\_\_\_  
 Unit Serial Number: \_\_\_\_\_

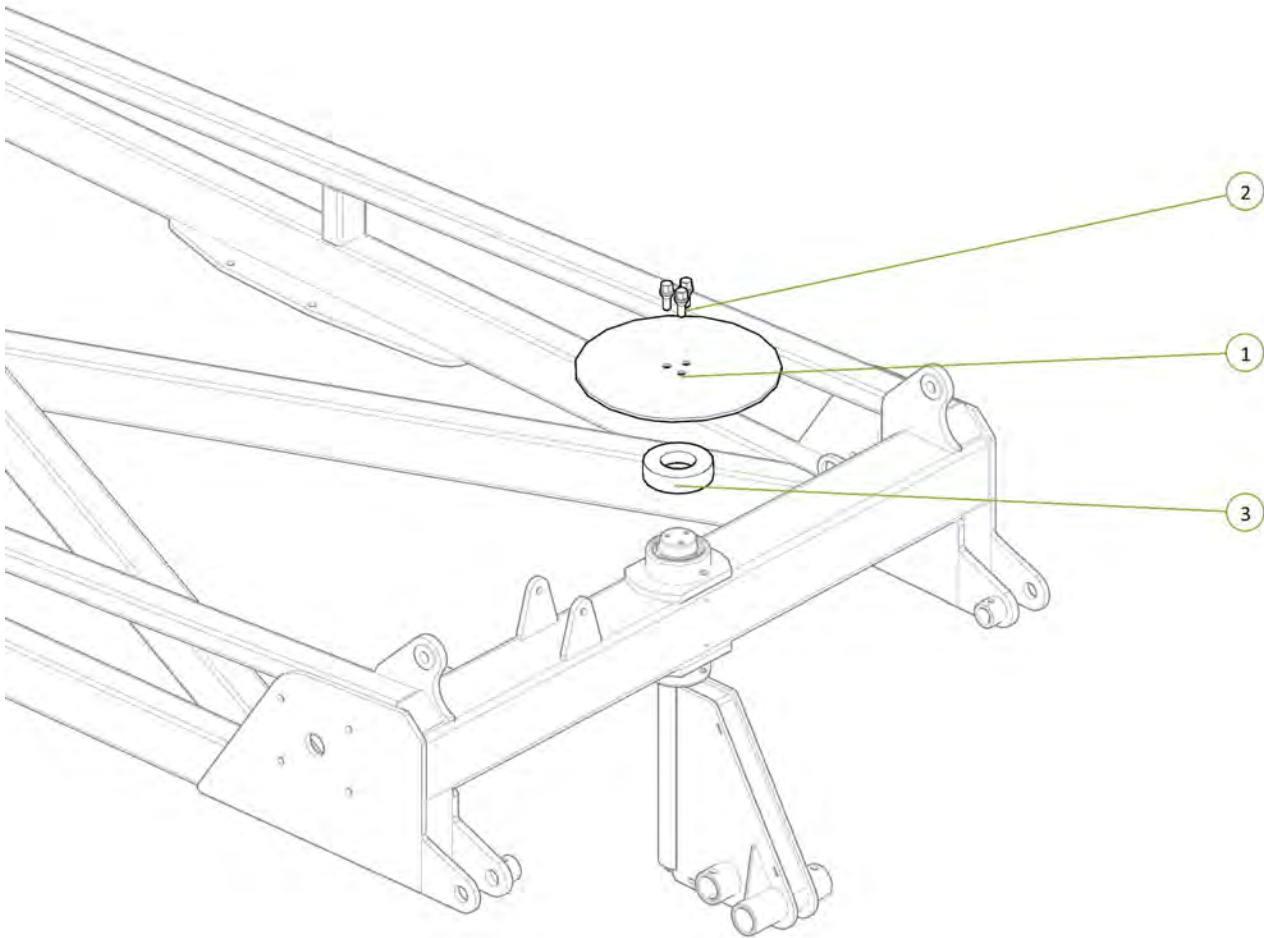
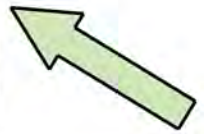

| Item No. | Description                                     | Number         | Qty |
|----------|---|----------------|-----|
| 1        | Brake Disc                                      | 1600-405       | 1   |
| 2        | M12 x 24 Wheel Bolt                             | 0216-WB1224    | 3   |
| 3        | Bolt on Brake Disc Dust Cap 70 ID x 135 OD x 35 | 1601-DC7013535 | 1   |



Wheel bolts torqued to 65ft-lb / 88nm 

Signed \_\_\_\_\_ Date \_\_\_/\_\_\_/\_\_\_  
Unit Serial Number: \_\_\_\_\_

| Item No. | Description                 | Number       | Qty |
|----------|-----------------------------|--------------|-----|
| 1        | Jockey Wheel Brake Caliper  | 0810-12CAL   | 9   |
| 2        | Brake Compression Spring    | 0801-KE009   | 1   |
| 3        | Washer Square M16 x 50 x 5  | 0231-SQ16505 | 1   |
| 4        | M16 x 150 grade 8.8 zp Bolt | 0211-16150   | 2   |
| 5        | Nyloc Nut M16               | 0221-NYL16   | 1   |

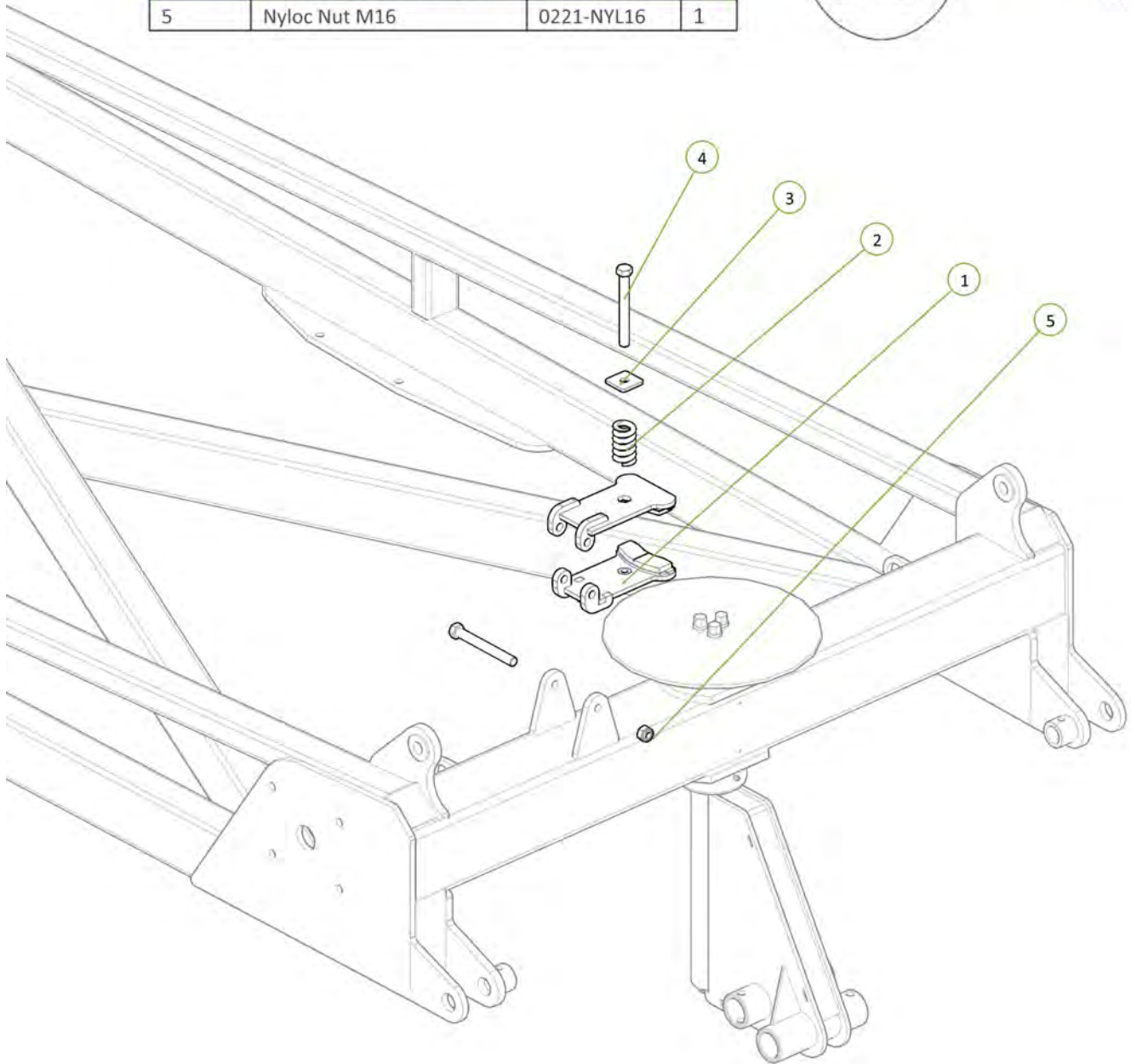
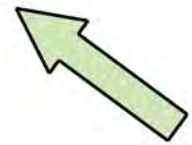

Check tension of brake caliper spring (50-63mm road transport)

Signed \_\_\_\_\_ Date \_\_\_/\_\_\_/\_\_\_  
 Unit Serial Number: \_\_\_\_\_

| Item No. | Description                     | Number         | Qty |
|----------|---------------------------------|----------------|-----|
| 1        | Axle 2"R 3T 6 on 6" PCD 330 OHF | 0733-K5083T66S | 2   |
| 2        | M16 x 90 grade 8.8 zp Bolt      | 0211-1690      | 2   |
| 3        | Nyloc Nut M16                   | 0221-NYL16     | 2   |

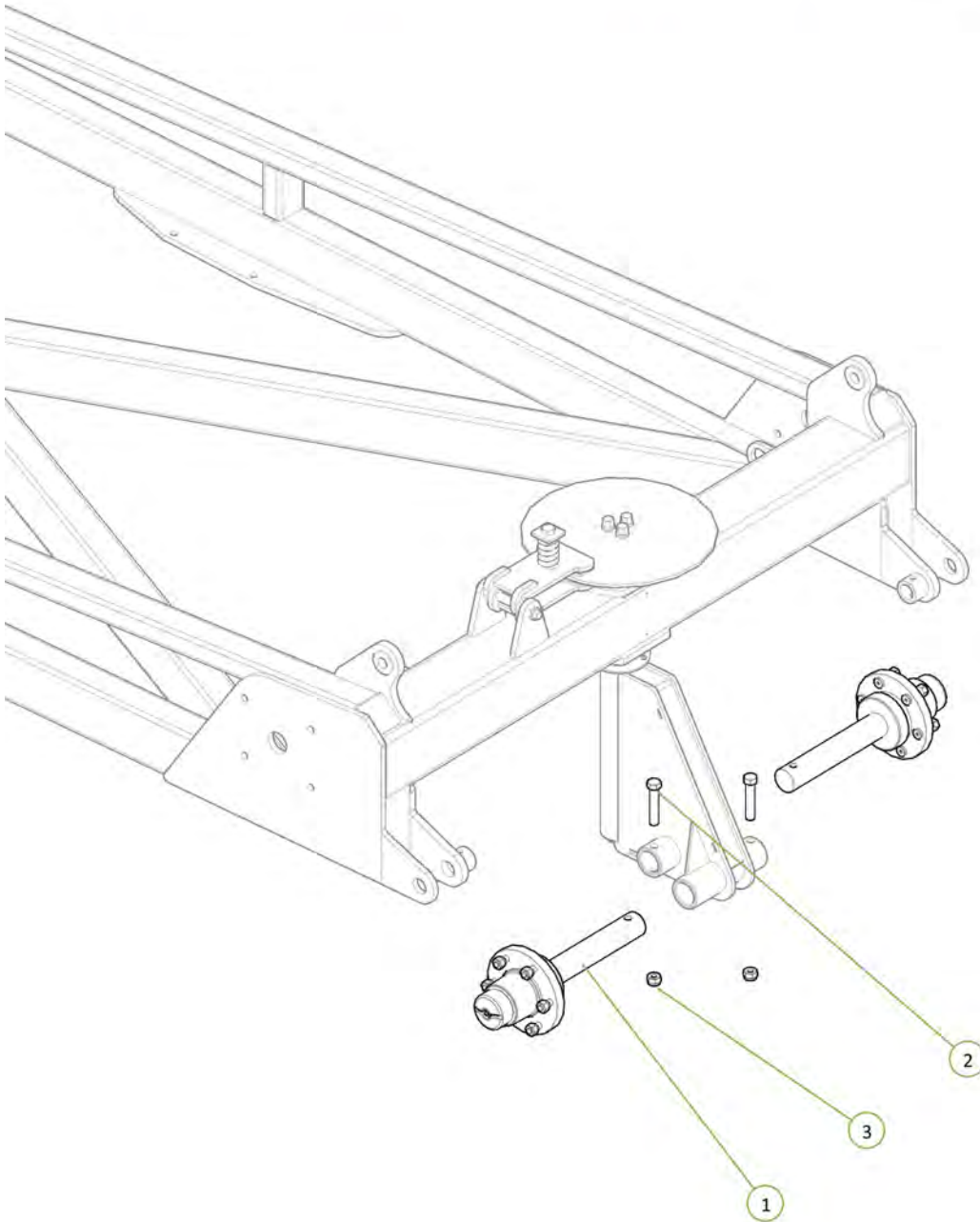
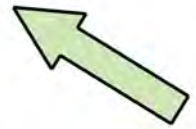



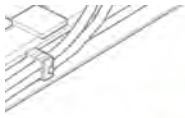

| Item No. | Description                       | Number     | Qty |
|----------|-----------------------------------|------------|-----|
| 1        | 11L15 F3 Tyre on 6 on 6" Stud Rim | 0751-11L15 | 2   |

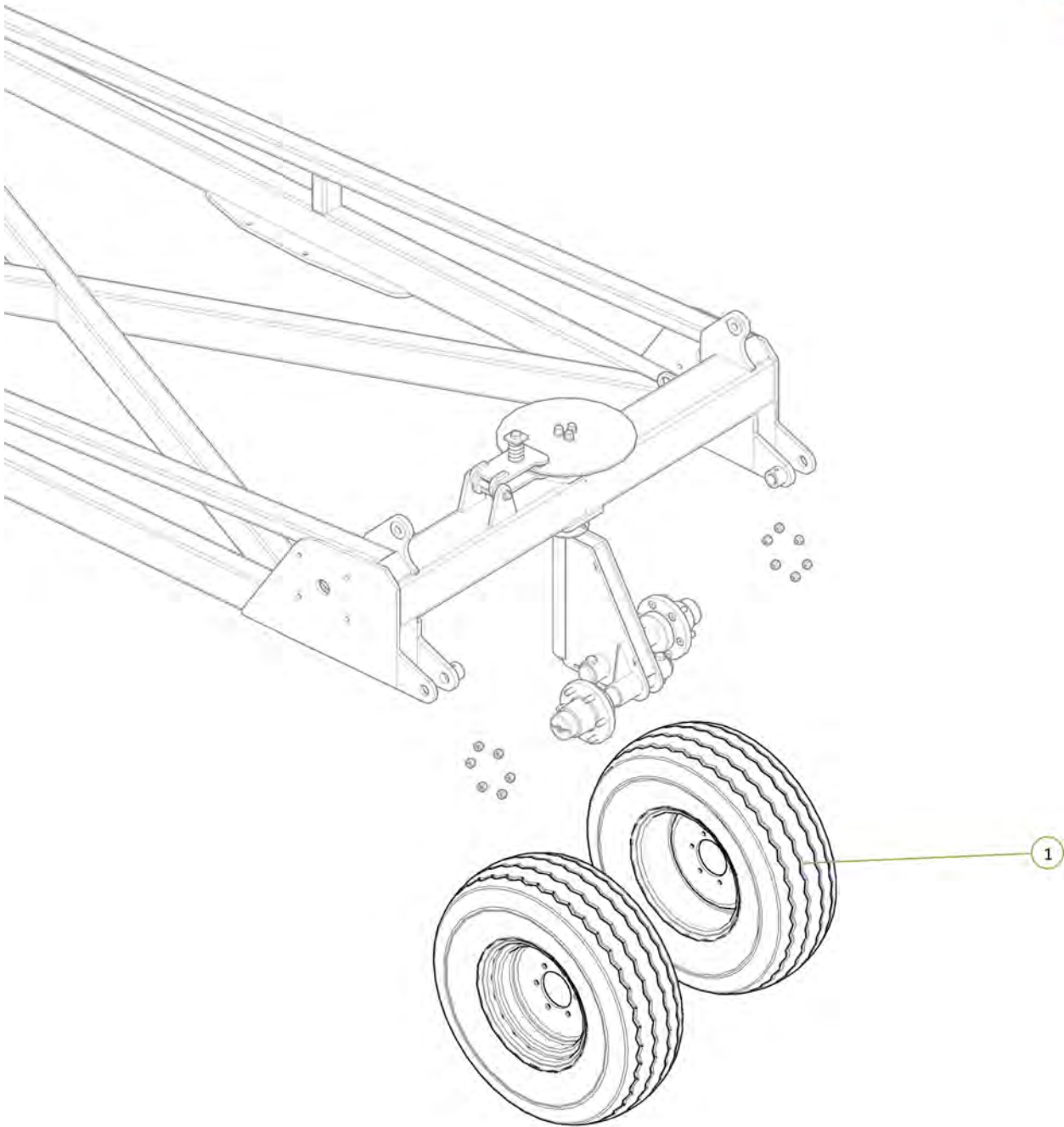
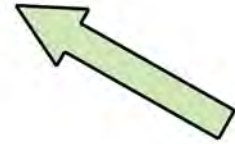

All wheel nuts tightened to 90ft-lb / 125nm 

Signed \_\_\_\_\_ Date \_\_\_ / \_\_\_ / \_\_\_  
Unit Serial Number: \_\_\_\_\_

| Item No. | Description                | Number         | Qty |
|----------|----------------------------|----------------|-----|
| 1        | Extended Tip Rear Tail     | 0810-10E       | 1   |
| 2        | Tail Frame Pivot pin       | 0801-10-08-175 | 2   |
| 3        | M12 x 65 grade 8.8 ZP Bolt | 0211-1265      | 2   |
| 4        | Nyloc Nut M12              | 0221-NYL12     | 2   |
| 5        | Cotter Pin M13 x 63        | 0261-PINC1363  | 2   |

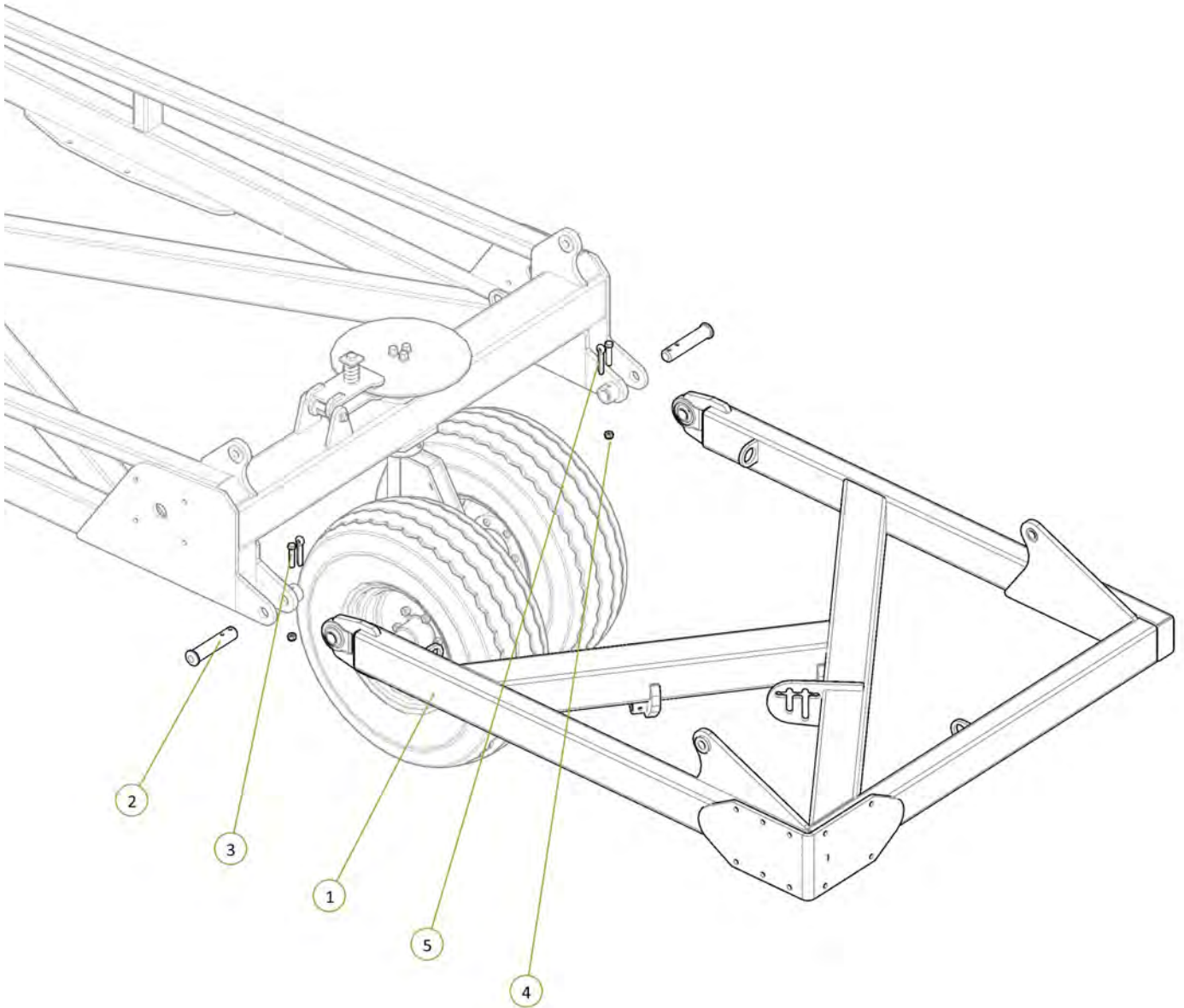
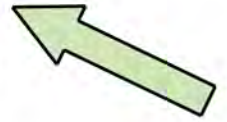

| Item No. | Description                                       | Number      | Qty |
|----------|---|-------------|-----|
| 1        | 3.5" Bore 24" Stroke 1.75" Rod Hydraulic Cylinder | 0311-3524SP | 2   |

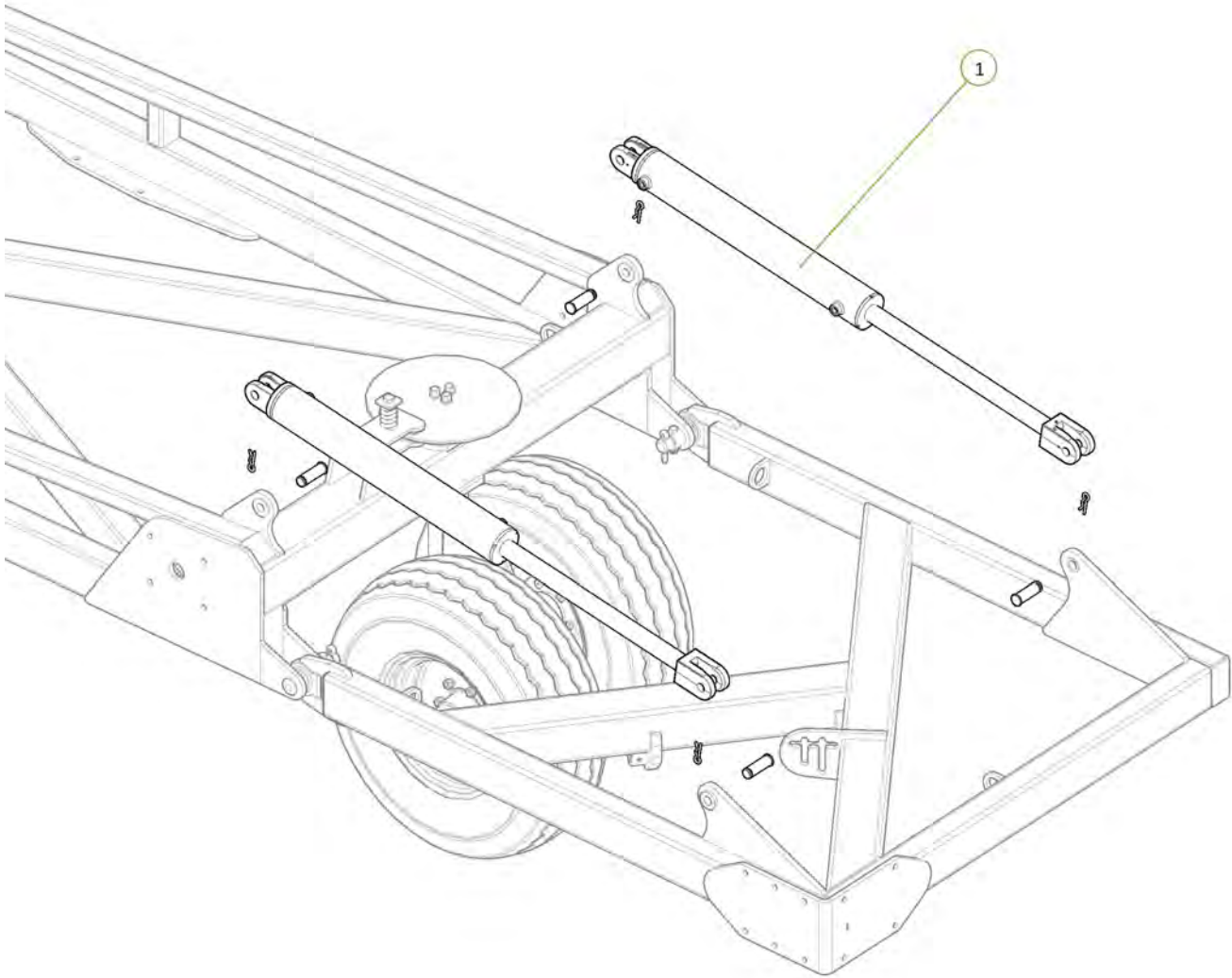
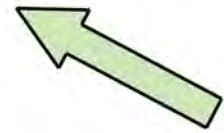

| Item No. | Description                                 | Number        | Qty |
|----------|---|---------------|-----|
| 1        | 3/4" JIC Male 3/4" UN O Ring Male 90° Elbow | 0323-S91-1212 | 4   |

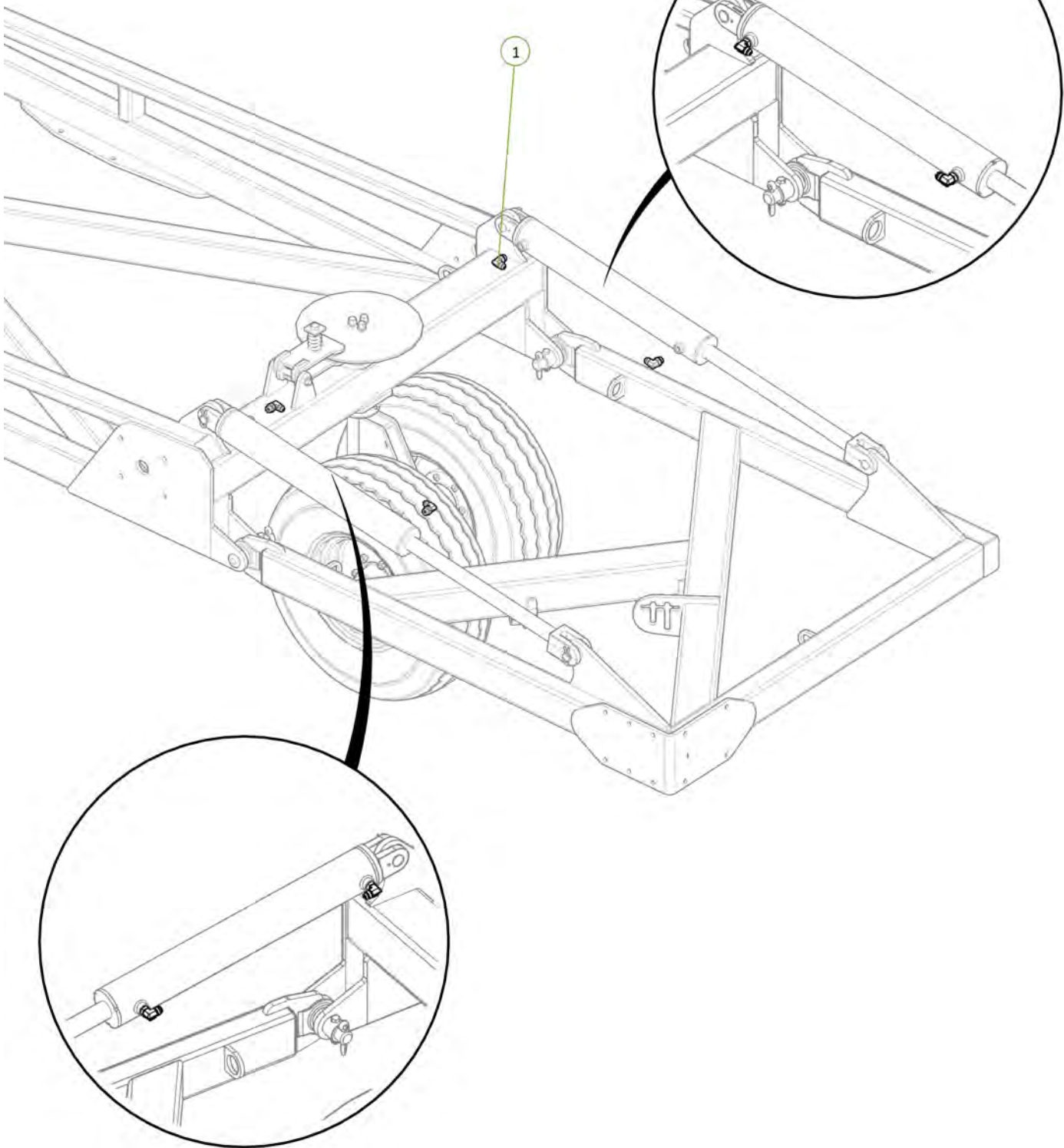
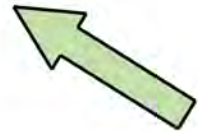



| Item No. | Description   | Number          | Qty |
|----------|---|-----------------|-----|
| 1        | TE1 Port to Tail Extend Tee                           | PH40-04         | 1   |
| 2        | TR1 Port to Tail Retract Tee                          | PH40-05         | 1   |
| 3        | 3/4" JIC Male Tee 3/4" JIC Male Tee 3/4" JIC Male Tee | 0324-S19-121212 | 2   |

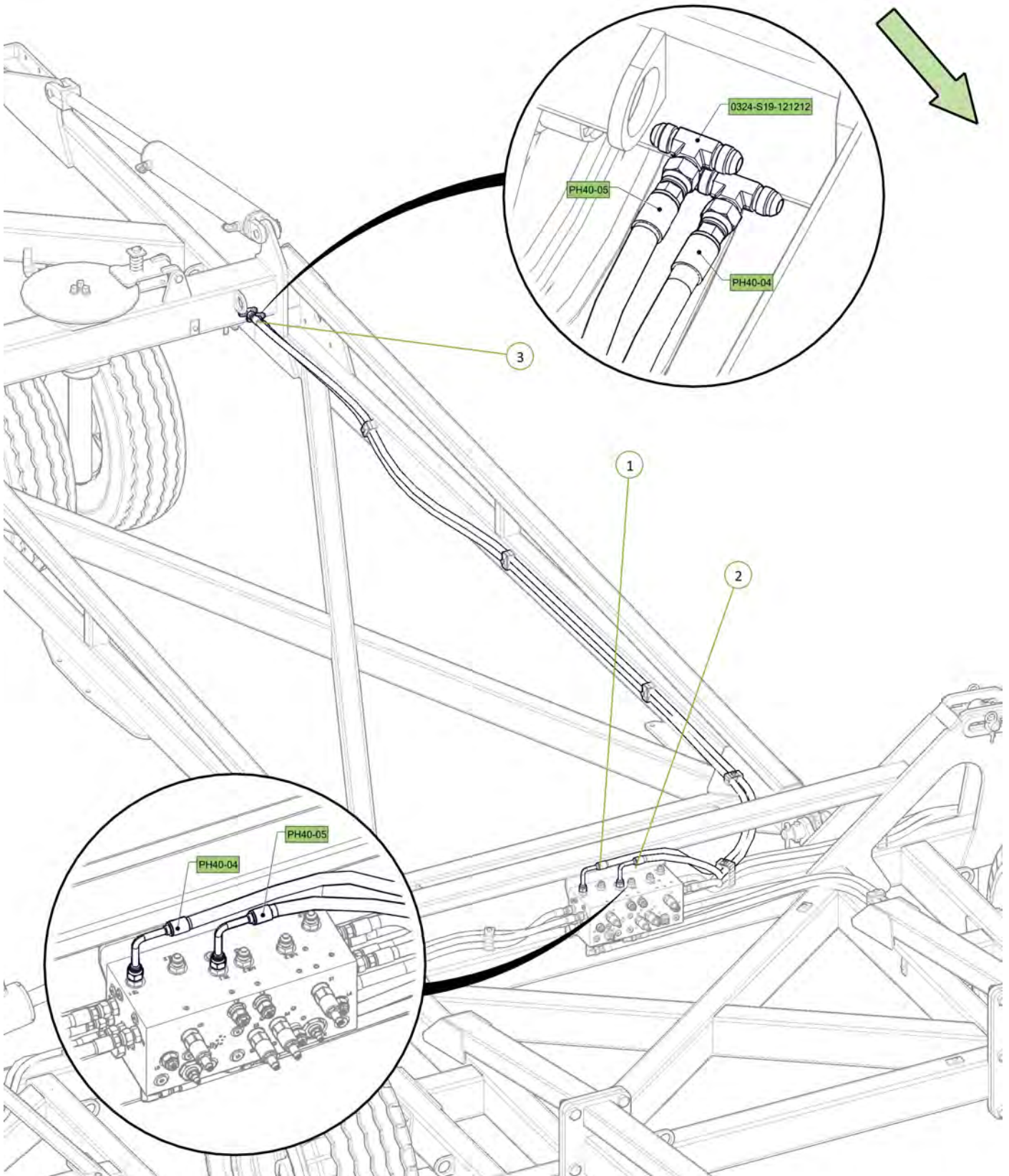

| Item No. | Description   | Number  | Qty |
|----------|---|---------|-----|
| 1        | Tail Lift Extend Tee to LH Tail Lift Extend Port            | PH40-20 | 1   |
| 2        | Tail Lift Retract Tee to LH Tail Lift Cylinder Retract Port | PH40-21 | 1   |

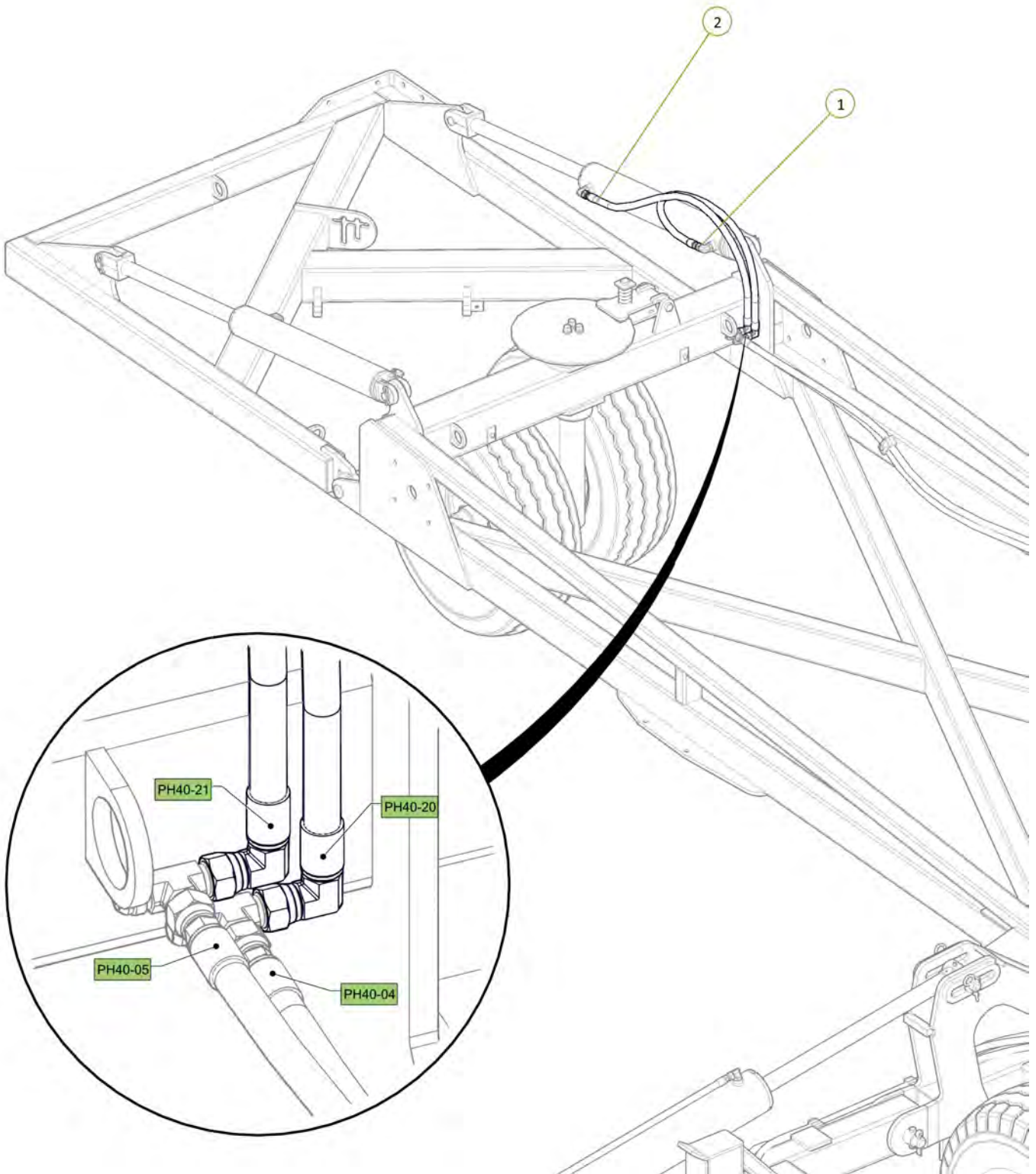
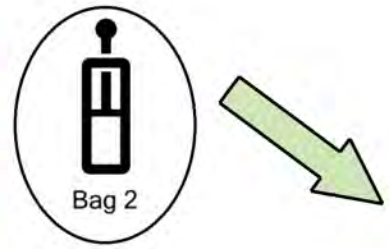



| Item No. | Description   | Number  | Qty |
|----------|---|---------|-----|
| 1        | Tail Lift Extend Tee to RH Tail Lift Cylinder Extend Port   | PH40-22 | 1   |
| 2        | Tail Lift Retract Tee to RH Tail Lift Cylinder Retract Port | PH40-23 | 1   |

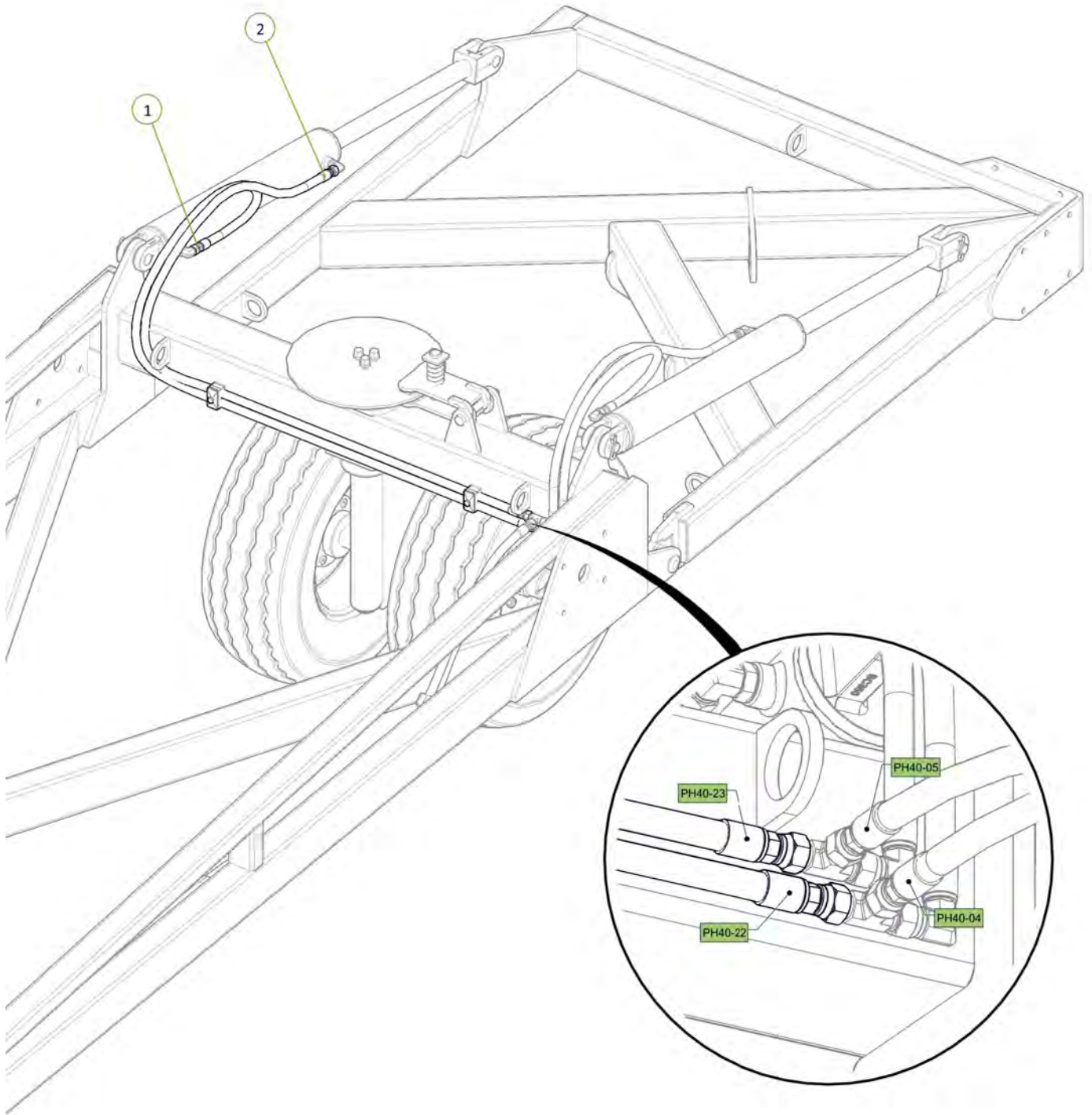

| Item No. | Description                   | Number     | Qty |
|----------|-------------------------------|------------|-----|
| 1        | Extended Tip Tail Bolt On Tip | 0810-10ET  | 1   |
| 2        | M16 x 50 grade 8.8 zp Bolt    | 0211-1650  | 10  |
| 3        | Nyloc Nut M16                 | 0221-NYL16 | 10  |
| 4        | Washer Flat M16               | 0231-F16   | 20  |

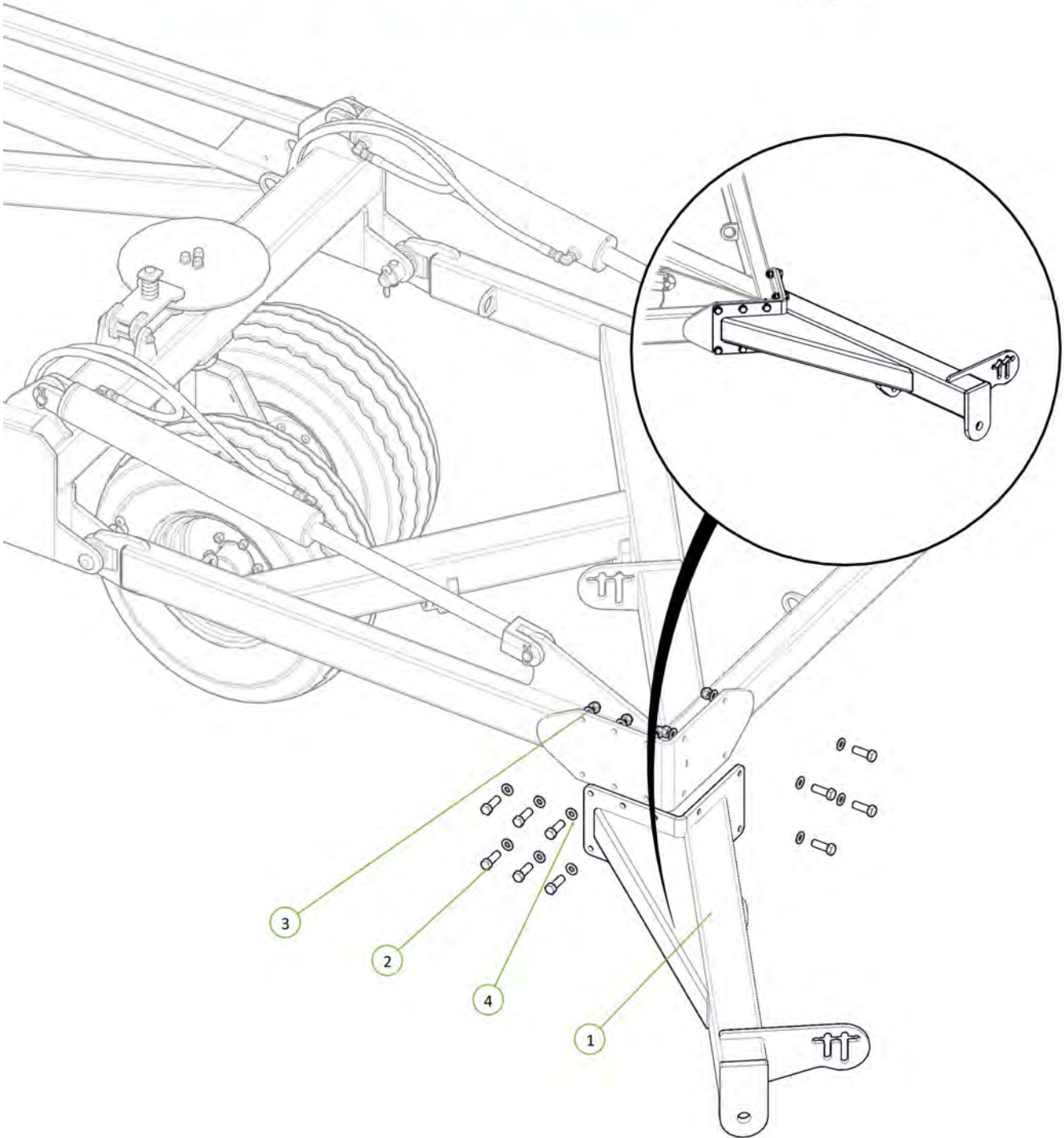
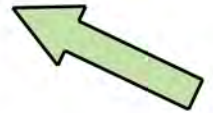



| Item No. | Description                | Number     | Qty |
|----------|----------------------------|------------|-----|
| 1        | 40' Front Module           | 0810-28-40 | 1   |
| 2        | M16 x 45 grade 8.8 zp Bolt | 0211-1645  | 8   |
| 3        | Nyloc Nut M16              | 0221-NYL16 | 8   |

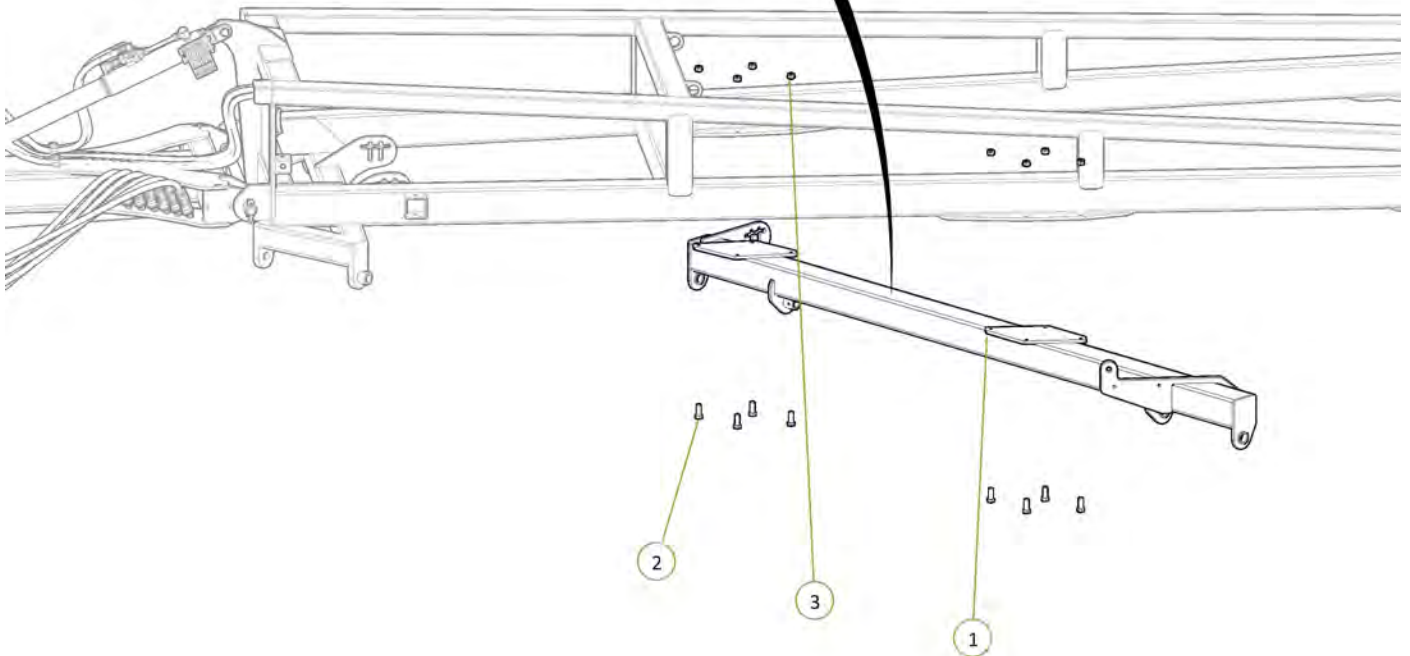
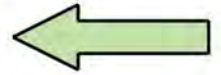

| Item No. | Description                | Number     | Qty |
|----------|----------------------------|------------|-----|
| 1        | 40' Rear Module            | 0810-29-40 | 1   |
| 2        | M16 x 45 grade 8.8 zp Bolt | 0211-1645  | 8   |
| 3        | Nyloc Nut M16              | 0221-NYL16 | 8   |

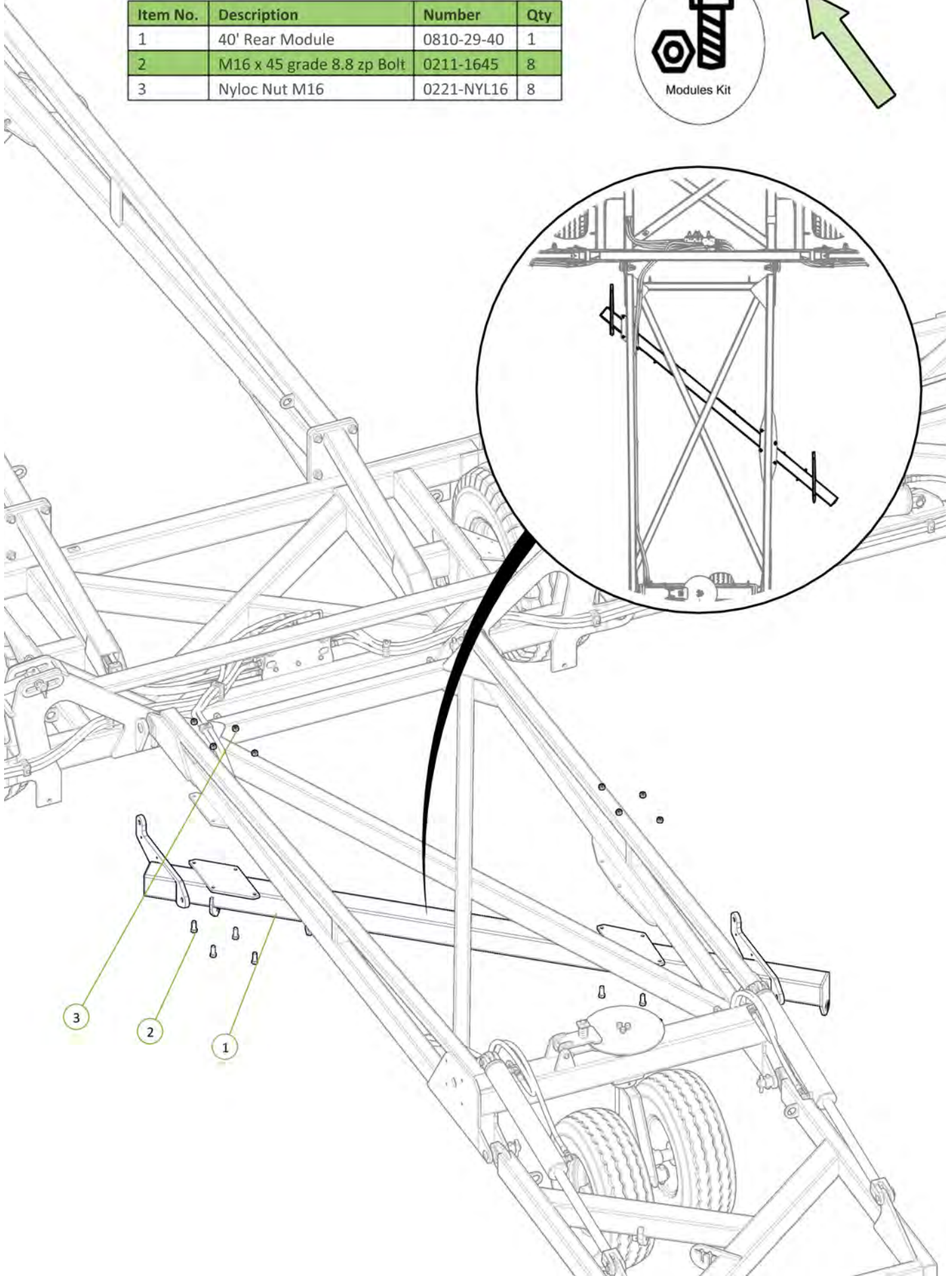
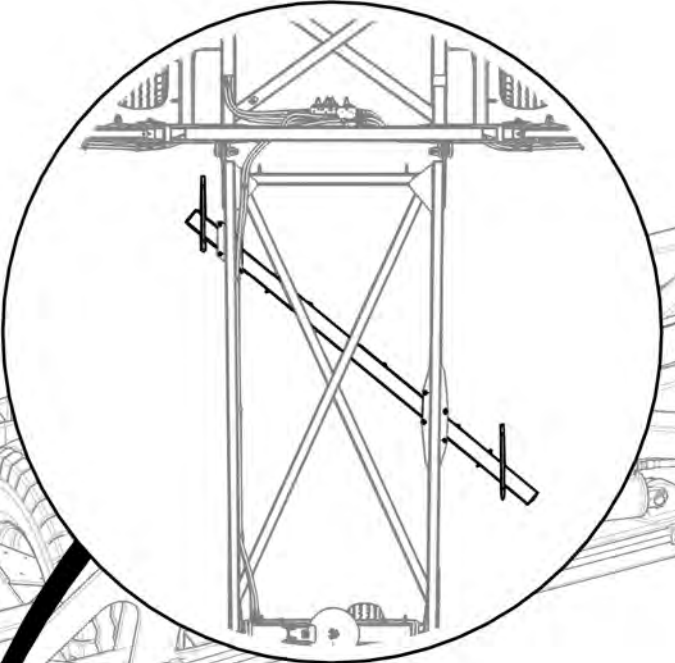

| Item No. | Description                  | Number         | Qty |
|----------|------------------------------|----------------|-----|
| 1        | LH Dropleg No Clevis         | 0810-24F       | 1   |
| 2        | RH Dropleg No Clevis         | 0810-25F       | 1   |
| 3        | LH Chain Adjusting Lug       | 0810-26        | 1   |
| 4        | RH Chain Adjusting Lug       | 0810-27        | 1   |
| 5        | Forged Clevis 21mm Bolt Hole | 0801-FC21      | 2   |
| 6        | Stainless Steel Wear Bush    | 1501-365033-SS | 2   |
| 7        | M24 x 140 grade 8.8 zp Bolt  | 0211-24140     | 2   |
| 8        | Nyloc Nut M24                | 0221-NYL24     | 2   |
| 9        | M36 x 105 grade 8.8 zp Bolt  | 0211-36105     | 2   |
| 10       | Nyloc Nut M36                | 0221-NYL36     | 2   |

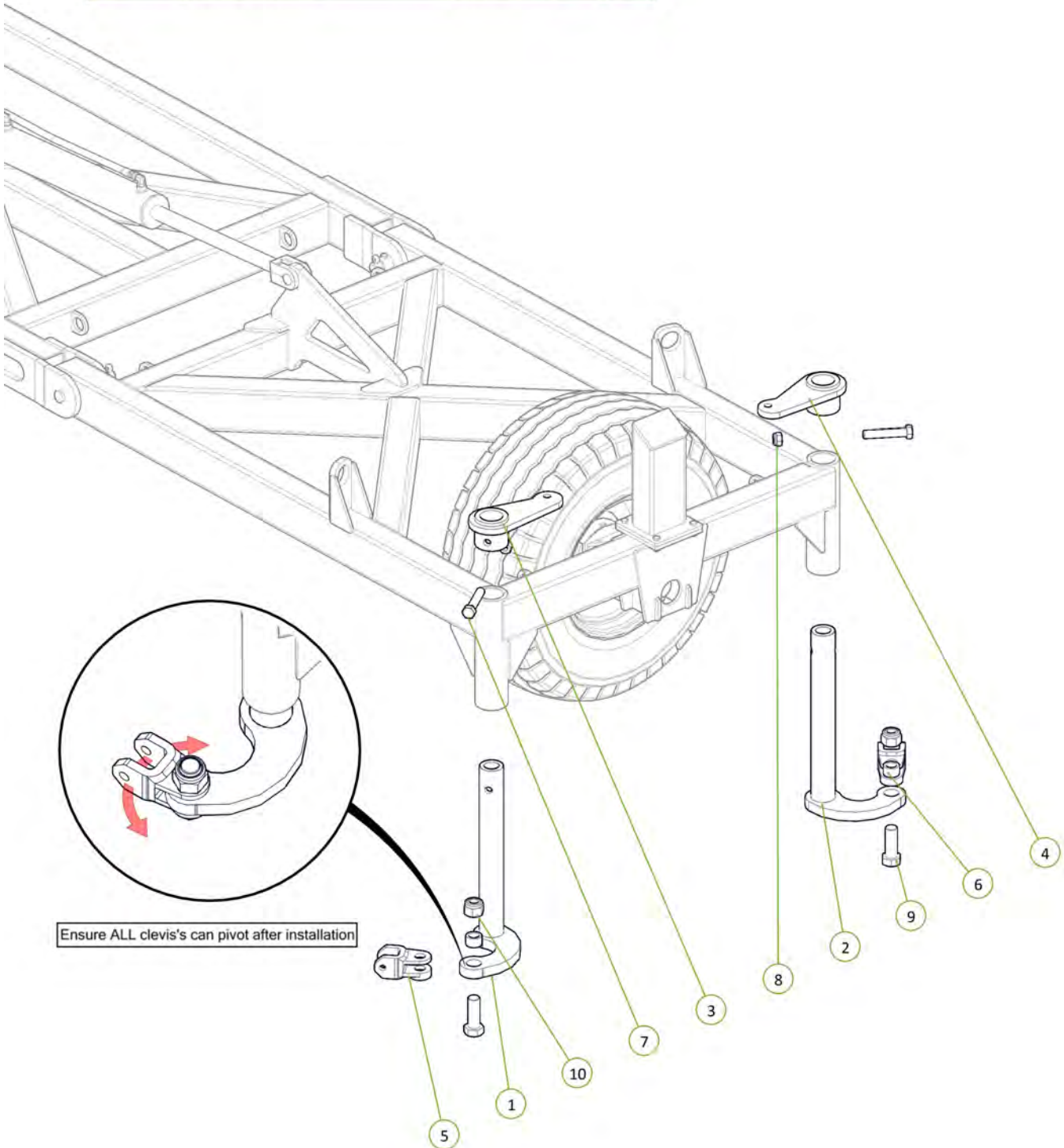
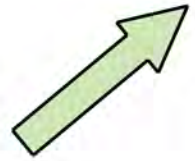



| Item No. | Description                | Number     | Qty |
|----------|----------------------------|------------|-----|
| 1        | Cast 25mm Spacing          | 0801-CS25  | 16  |
| 2        | M10 x 30 grade 8.8 ZP Bolt | 0211-1030  | 16  |
| 3        | Nyloc Nut M10              | 0221-NYL10 | 16  |

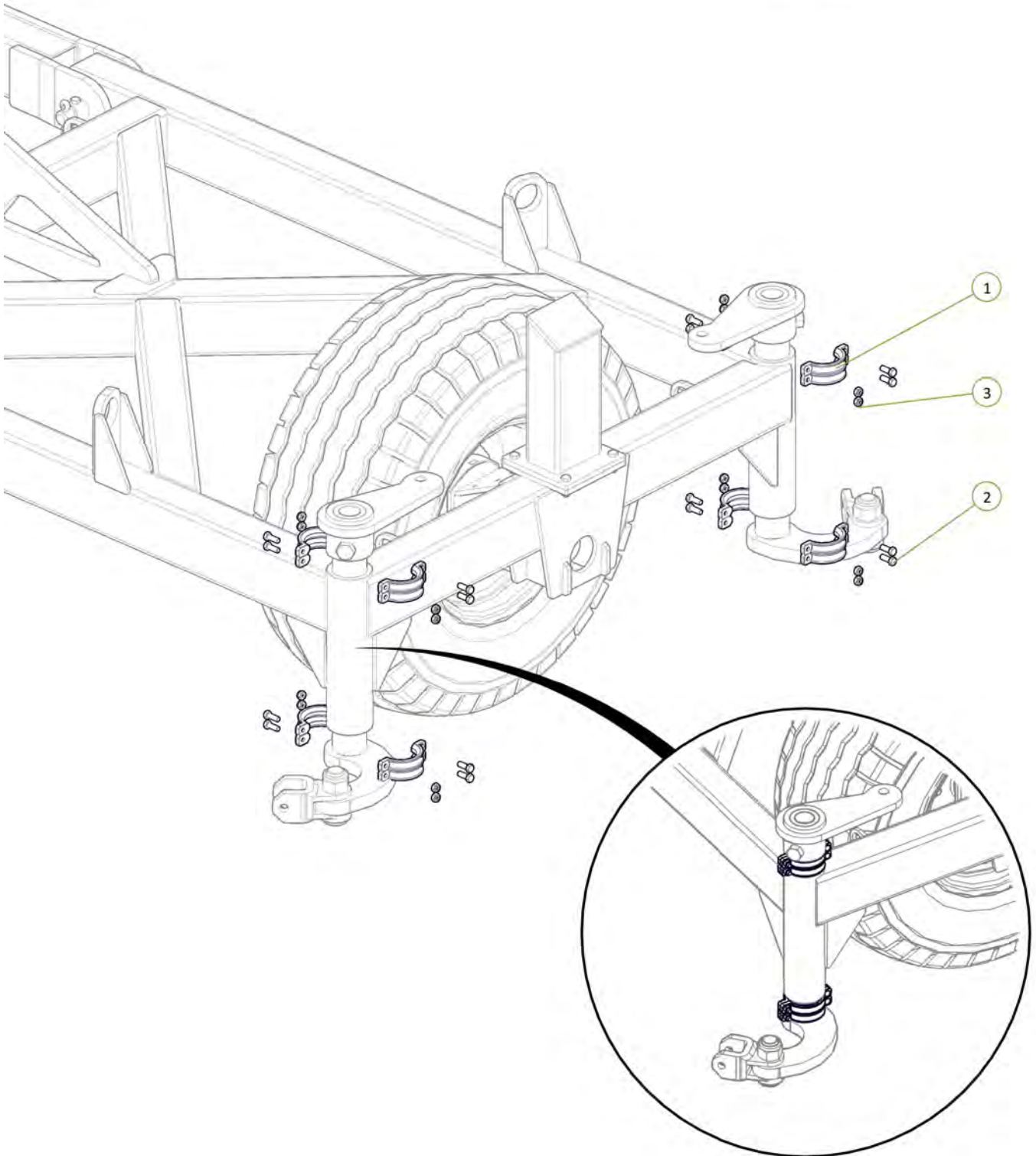
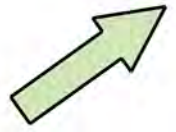



| Item No. | Description                | Number        | Qty |
|----------|----------------------------|---------------|-----|
| 1        | Chain Tension Adjustor     | 0802-PCHTA    | 2   |
| 2        | Washer High Tensile 1 1/4" | 0232-HT11-4   | 2   |
| 3        | 20mm Compression Spring    | 0801-XK9261S  | 2   |
| 4        | Tensioner Cup - Male       | 0801-KE0805-3 | 2   |
| 5        | Female Spring Locator      | 0801-KE0805-4 | 2   |

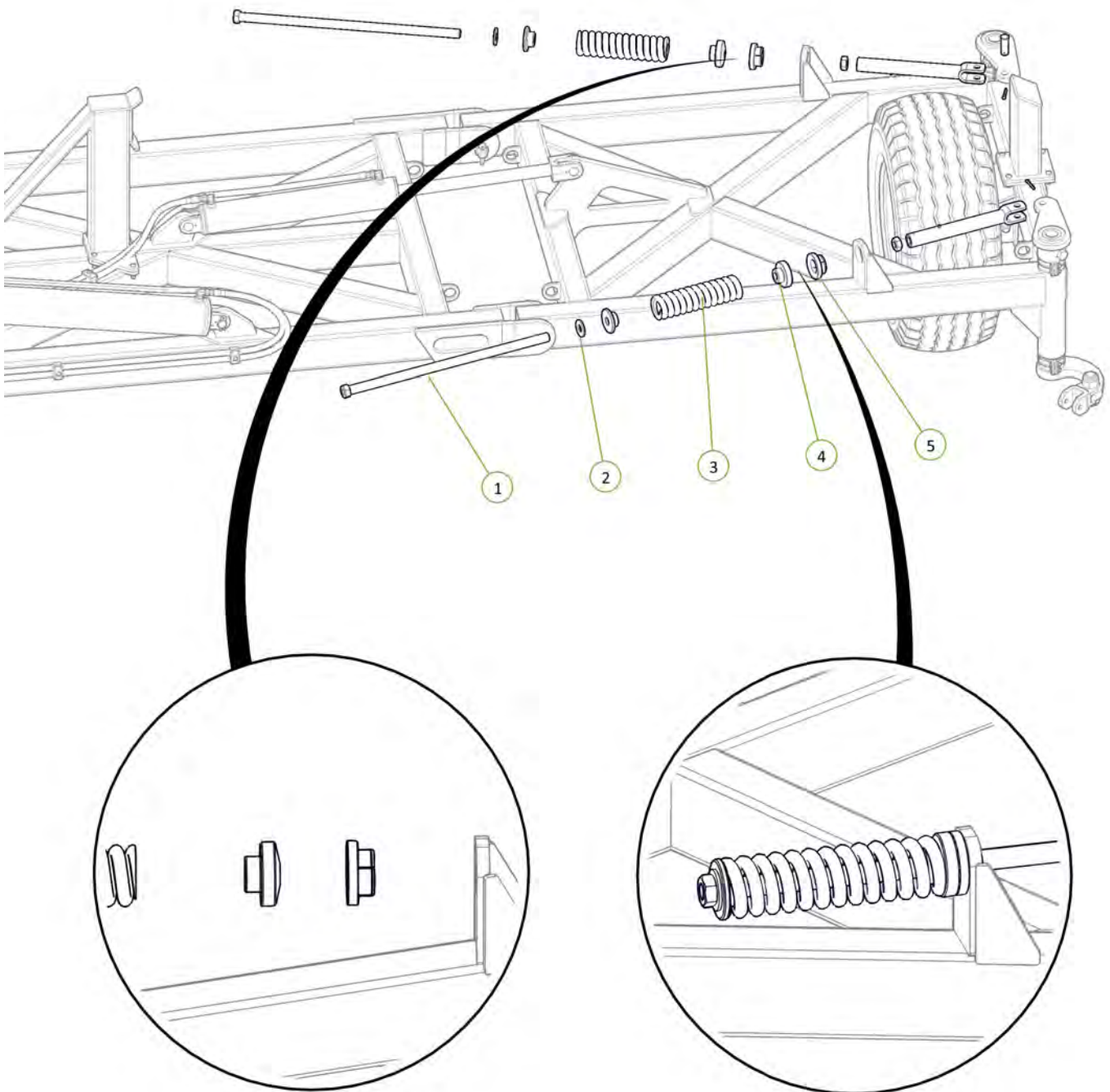

| Item No. | Description                  | Number         | Qty |
|----------|------------------------------|----------------|-----|
| 1        | LH Dropleg No Clevis         | 0810-24F       | 1   |
| 2        | RH Dropleg No Clevis         | 0810-25F       | 1   |
| 3        | LH Chain Adjusting Lug       | 0810-26        | 1   |
| 4        | RH Chain Adjusting Lug       | 0810-27        | 1   |
| 5        | Stainless Steel Wear Bush    | 1501-365033-SS | 2   |
| 6        | Forged Clevis 21mm Bolt Hole | 0801-FC21      | 2   |
| 7        | M36 x 105 grade 8.8 zp Bolt  | 0211-36105     | 2   |
| 8        | Nyloc Nut M36                | 0221-NYL36     | 2   |
| 9        | M24 x 140 grade 8.8 zp Bolt  | 0211-24140     | 2   |
| 10       | Nyloc Nut M24                | 0221-NYL24     | 2   |

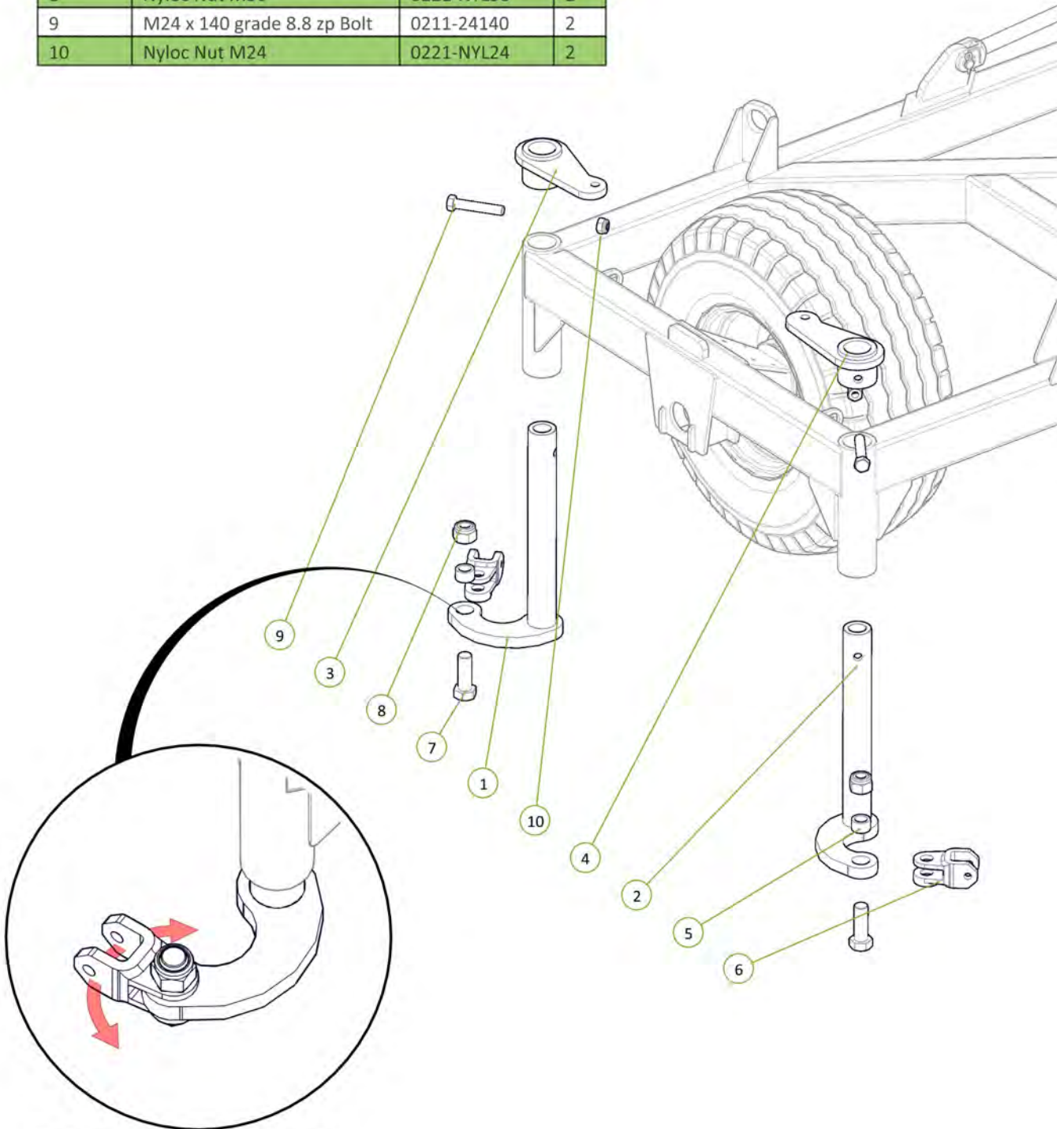

Ensure ALL clevis's can pivot after installation

| Item No. | Description                | Number     | Qty |
|----------|----------------------------|------------|-----|
| 1        | Cast 25mm Spacing          | 0801-CS25  | 16  |
| 2        | M10 x 30 grade 8.8 ZP Bolt | 0211-1030  | 16  |
| 3        | Nyloc Nut M10              | 0221-NYL10 | 16  |

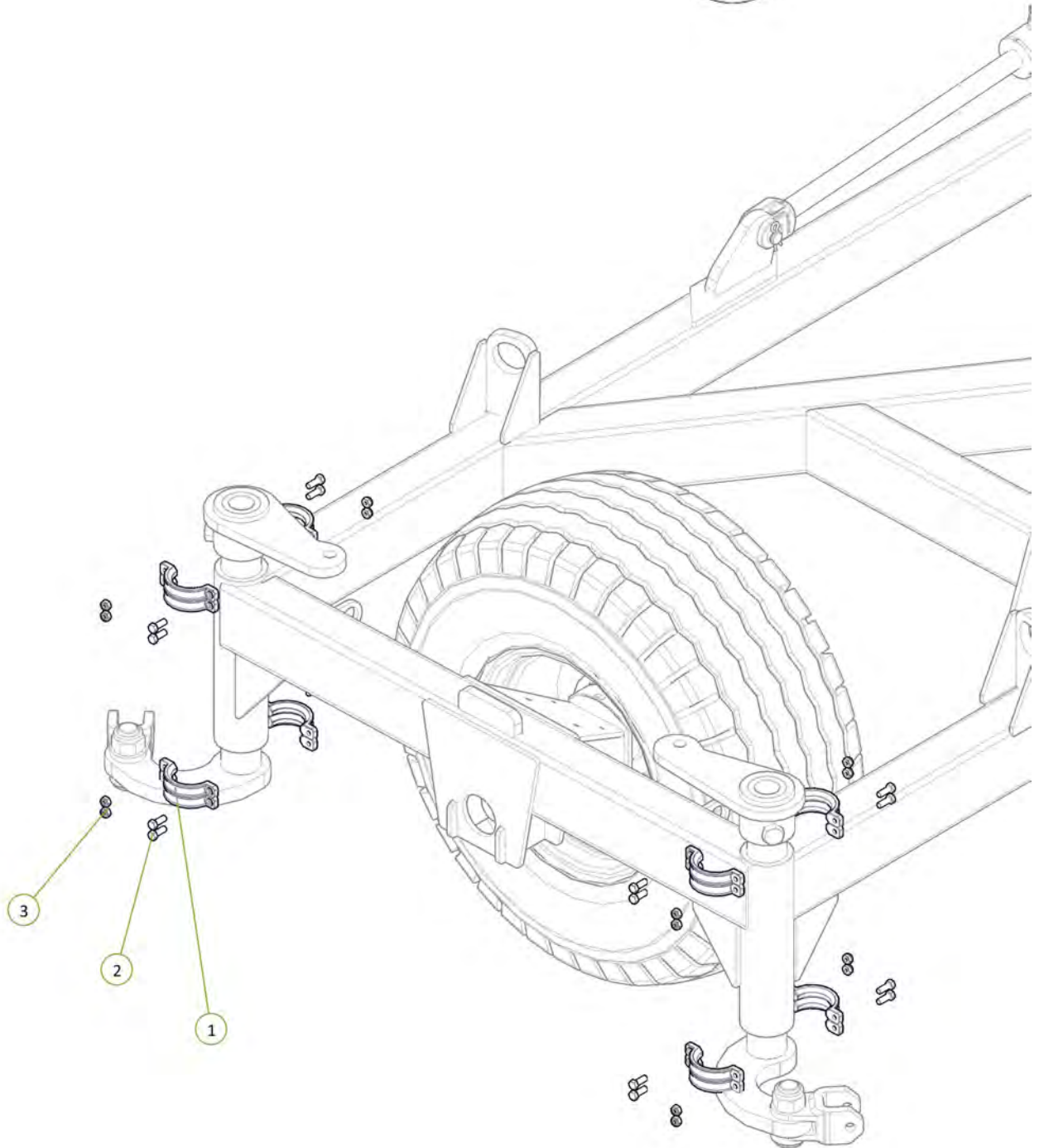
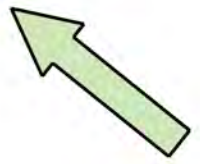



| Item No. | Description                | Number        | Qty |
|----------|----------------------------|---------------|-----|
| 1        | Chain Tension Adjustor     | 0802-PCHTA    | 2   |
| 2        | Washer High Tensile 1 1/4" | 0232-HT11-4   | 2   |
| 3        | 20mm Compression Spring    | 0801-XK9261S  | 2   |
| 4        | Tensioner Cup - Male       | 0801-KE0805-3 | 2   |
| 5        | Female Spring Locator      | 0801-KE0805-4 | 2   |

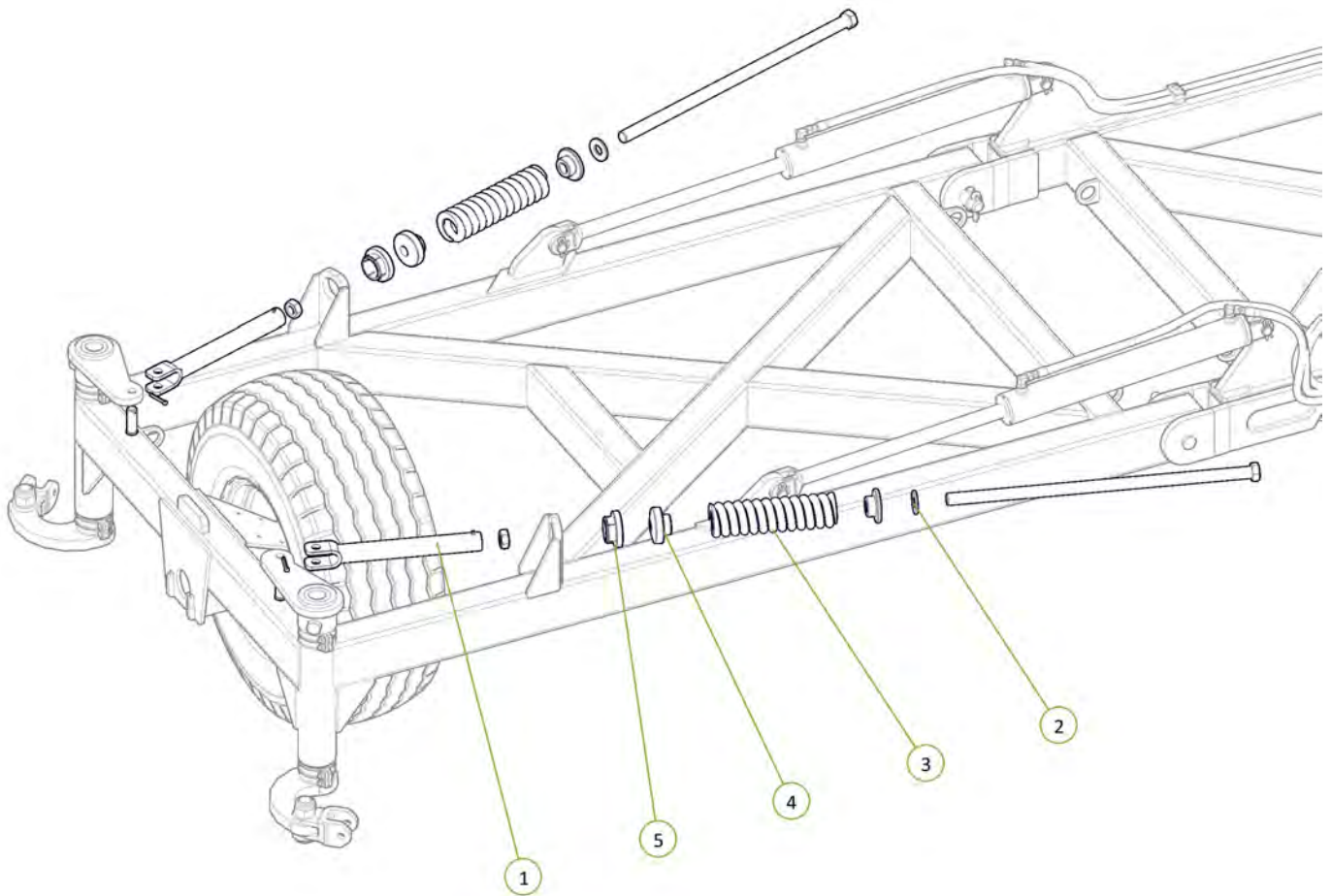



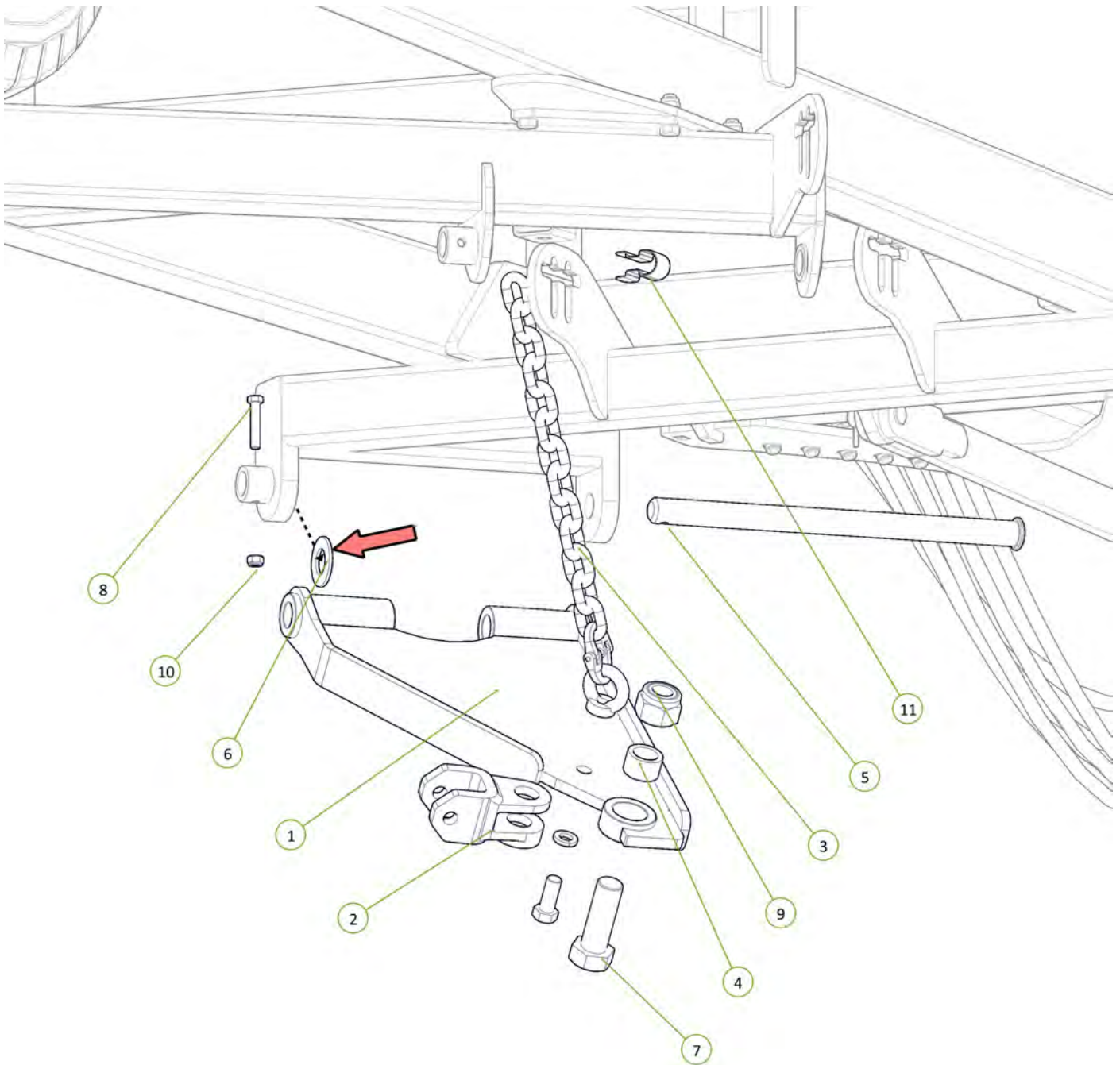

| Item No. | Description                     | Number         | Qty |
|----------|---------------------------------|----------------|-----|
| 1        | Standard Chain Mount Plate      | 0810-20        | 1   |
| 2        | Forged Clevis 21mm Bolt Hole    | 0801-FC21      | 1   |
| 3        | Height Adjusting Chain Assembly | 0801-20MCA     | 1   |
| 4        | Stainless Steel Wear Bush       | 1501-365033-SS | 1   |
| 5        | Chain Mount Pivot Pin           | 0801-10-51     | 1   |
| 6        | Washer High Tensile 1 3/8"      | 0232-HT13-8    | 1   |
| 7        | M36 x 105 grade 8.8 zp Bolt     | 0211-36105     | 1   |
| 8        | M12 x 65 grade 8.8 ZP Bolt      | 0211-1265      | 1   |
| 9        | Nyloc Nut M36                   | 0221-NYL36     | 1   |
| 10       | Nyloc Nut M12                   | 0221-NYL12     | 1   |
| 11       | Height Adjustor Retaining Clip  | 0801-KE014     | 1   |



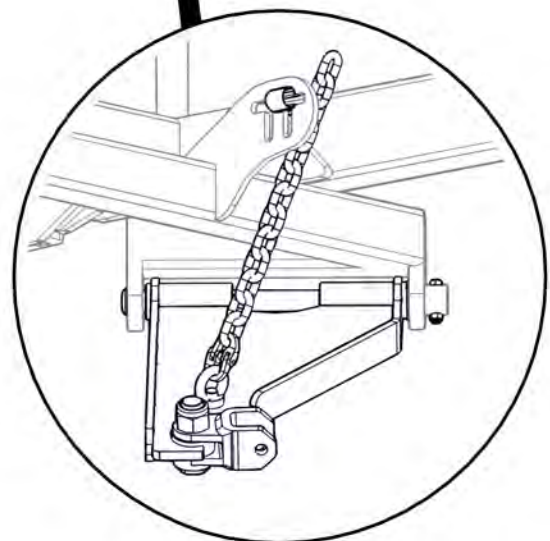
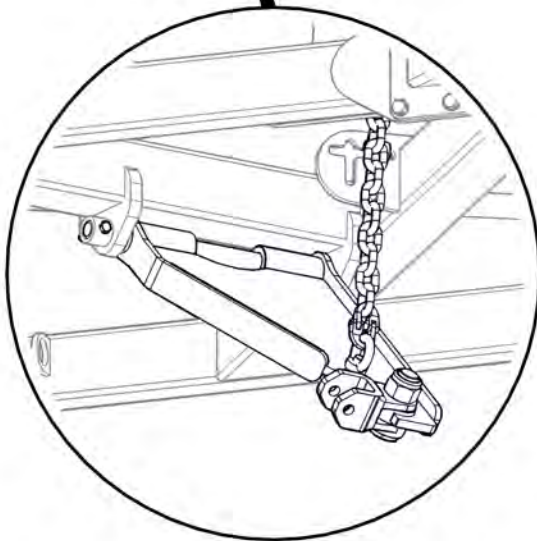
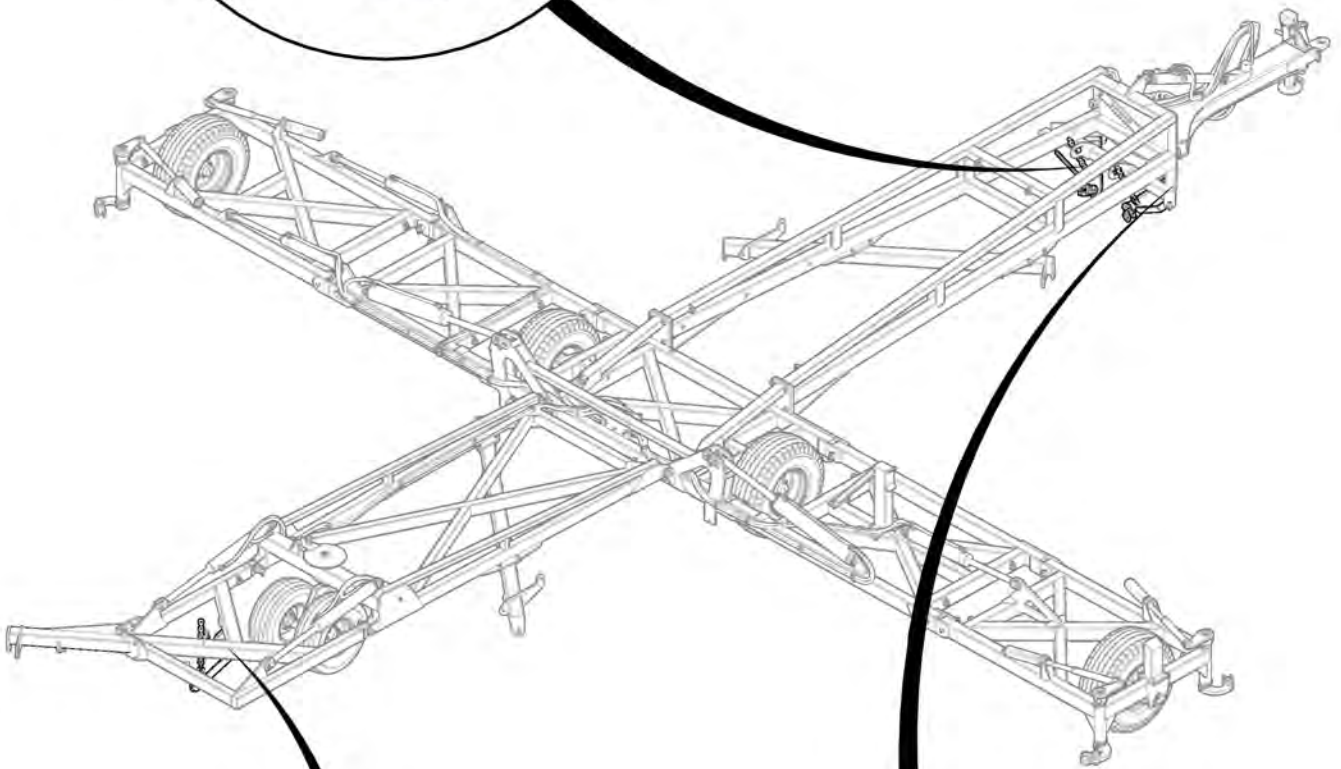
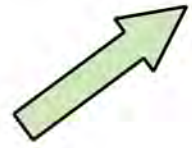
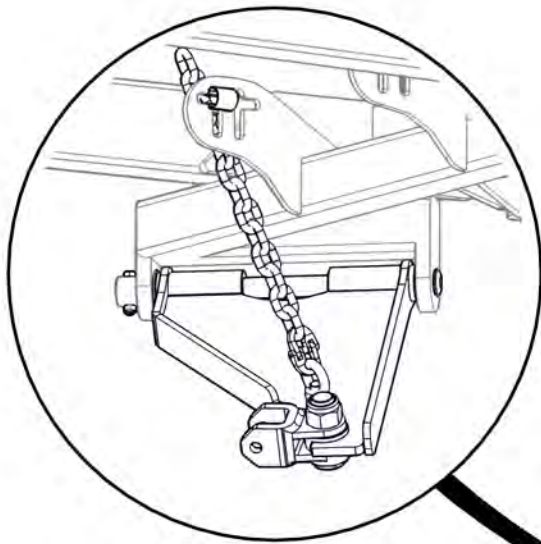

| Item No. | Description                     | Number         | Qty |
|----------|---------------------------------|----------------|-----|
| 1        | Extended Chain Mount Plate      | 0810-21        | 1   |
| 2        | Forged Clevis 21mm Bolt Hole    | 0801-FC21      | 1   |
| 3        | Height Adjusting Chain Assembly | 0801-20MCA     | 1   |
| 4        | Stainless Steel Wear Bush       | 1501-365033-SS | 1   |
| 5        | Chain Mount Pivot Pin           | 0801-10-51     | 1   |
| 6        | M36 x 105 grade 8.8 zp Bolt     | 0211-36105     | 1   |
| 7        | Nyloc Nut M36                   | 0221-NYL36     | 1   |
| 8        | Washer High Tensile 1 3/8"      | 0232-HT13-8    | 1   |
| 9        | M12 x 65 grade 8.8 ZP Bolt      | 0211-1265      | 1   |
| 10       | Nyloc Nut M12                   | 0221-NYL12     | 1   |
| 11       | Height Adjustor Retaining Clip  | 0801-KE014     | 1   |

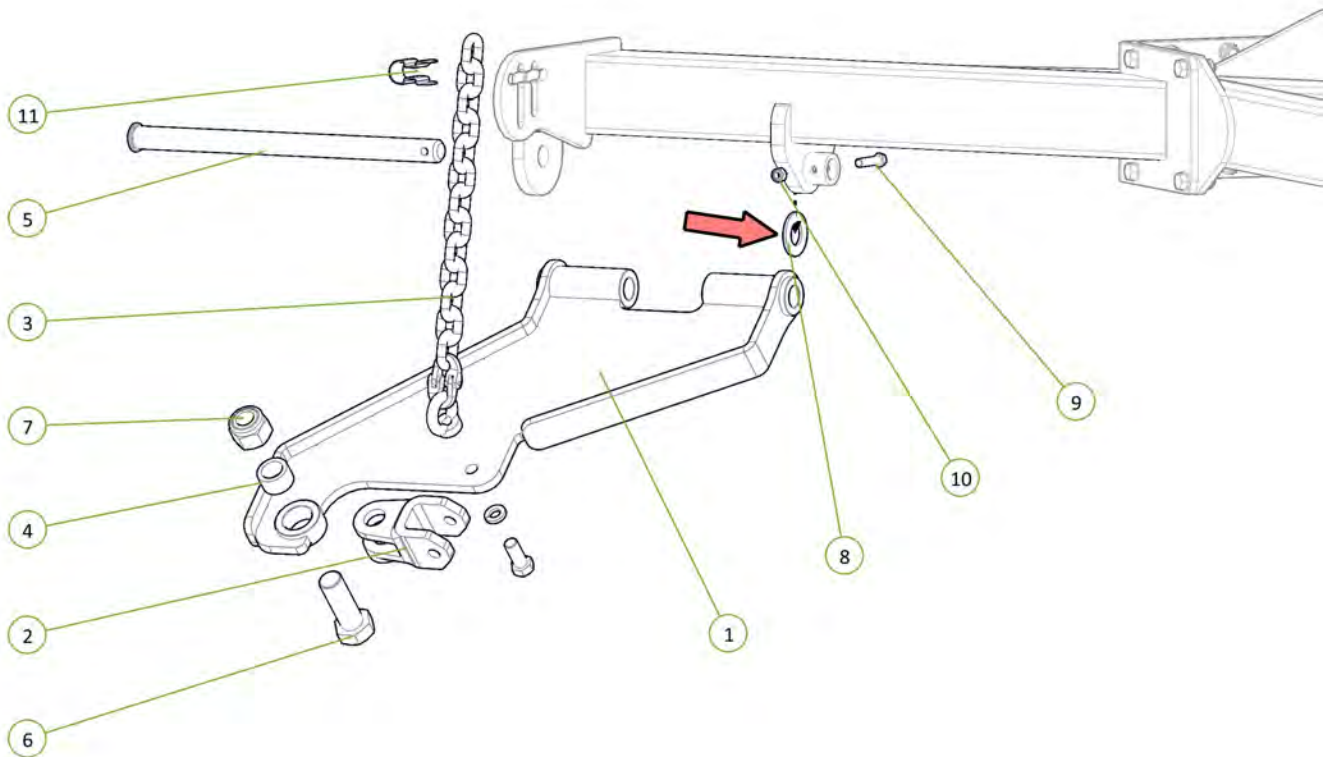
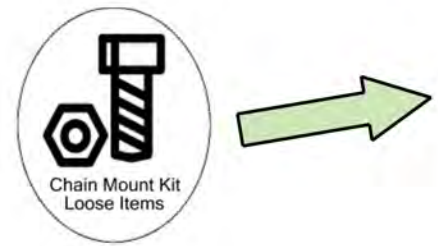



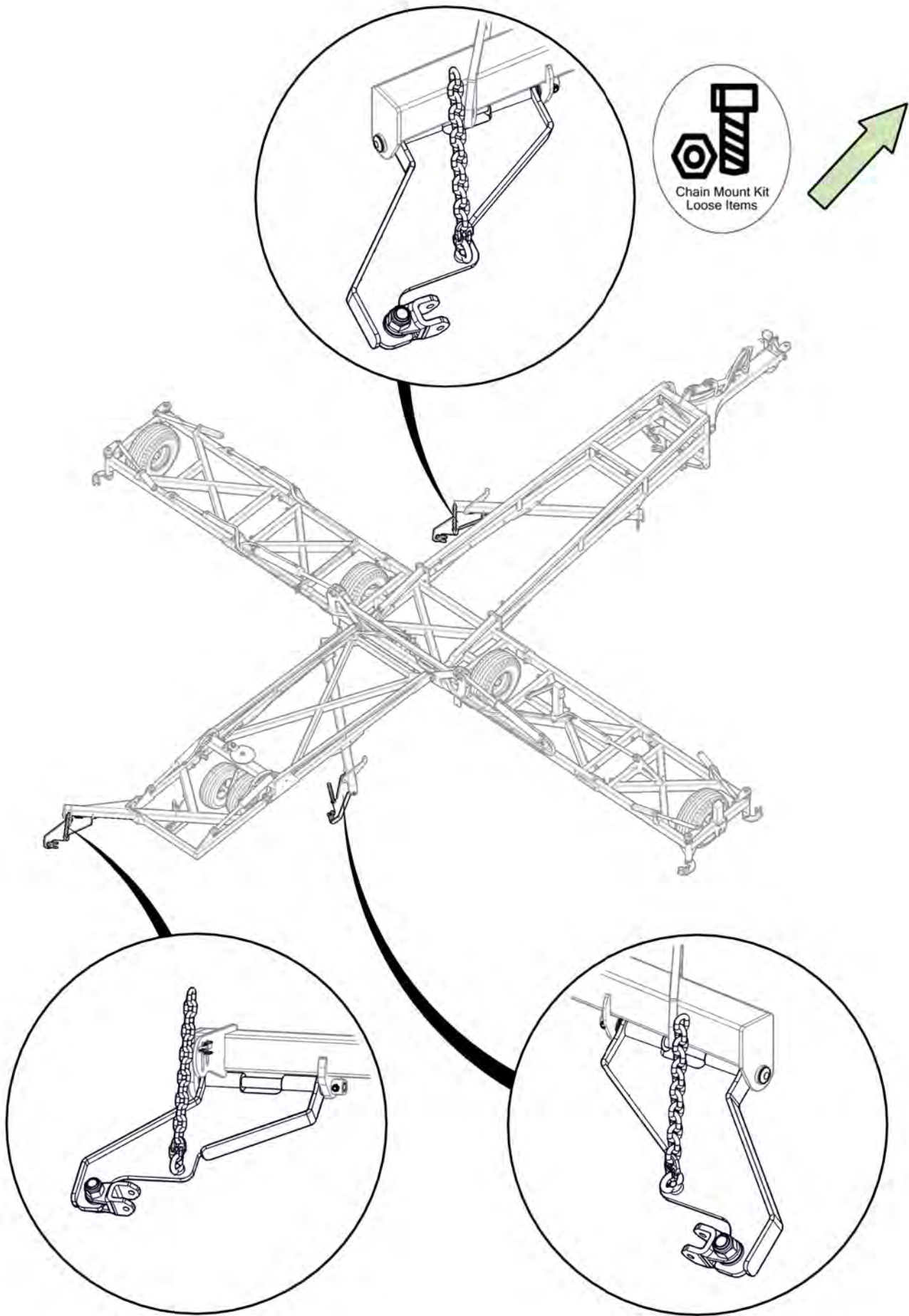



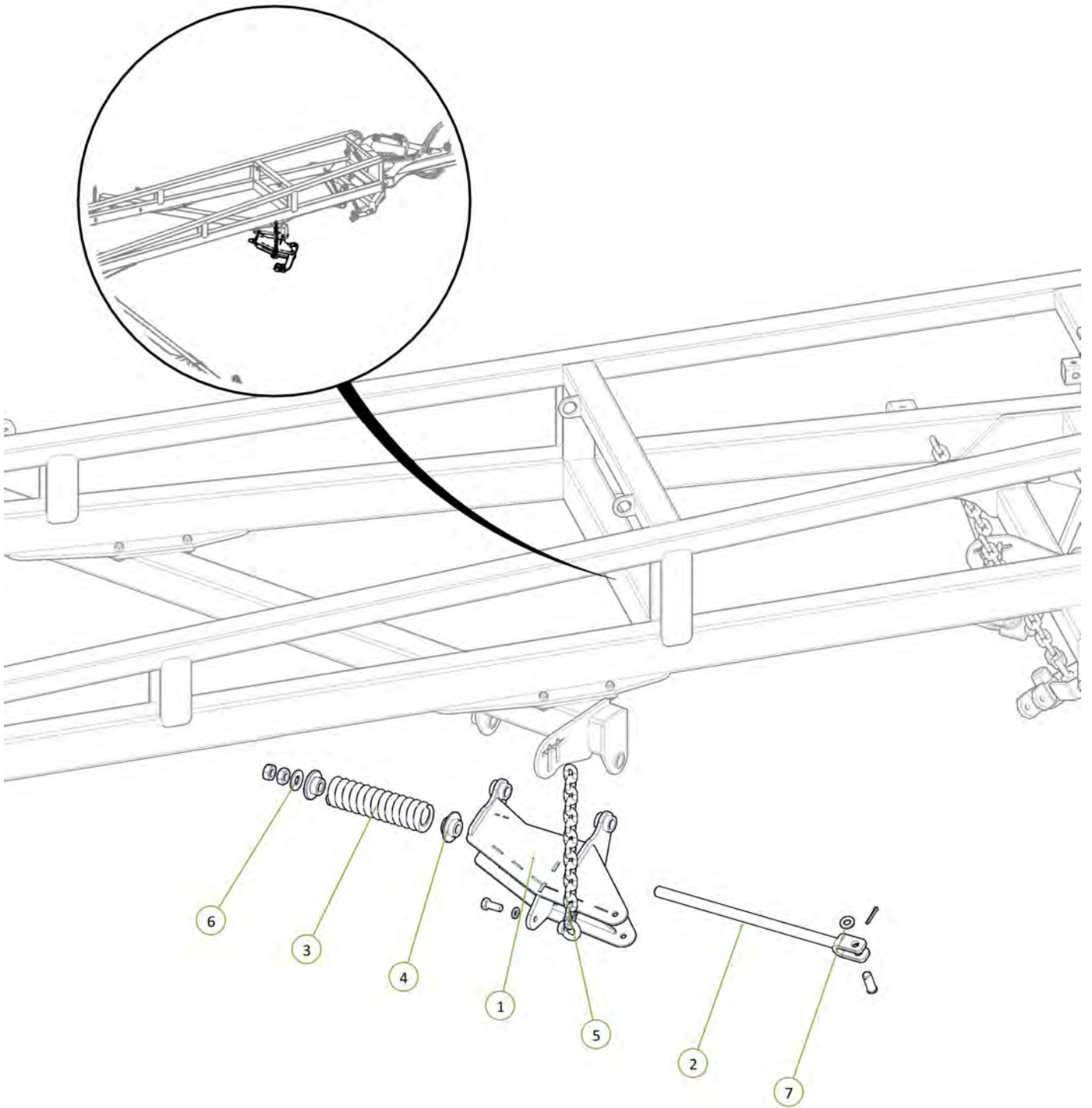

| Item No. | Description                     | Number       | Qty |
|----------|---------------------------------|--------------|-----|
| 1        | Rear Module Tension Body        | 0810-103R    | 1   |
| 2        | Module Tension Rod Assembly     | 0810-105A    | 1   |
| 3        | 20mm Compression Spring         | 0801-XK9261S | 1   |
| 4        | Rigid Spring Locator            | 0801-10-S2L  | 1   |
| 5        | Height Adjusting Chain Assembly | 0801-20MCA   | 1   |
| 6        | Washer High Tensile 1 1/4"      | 0232-HT11-4  | 1   |
| 7        | Washer Flat M24                 | 0231-F24     | 1   |



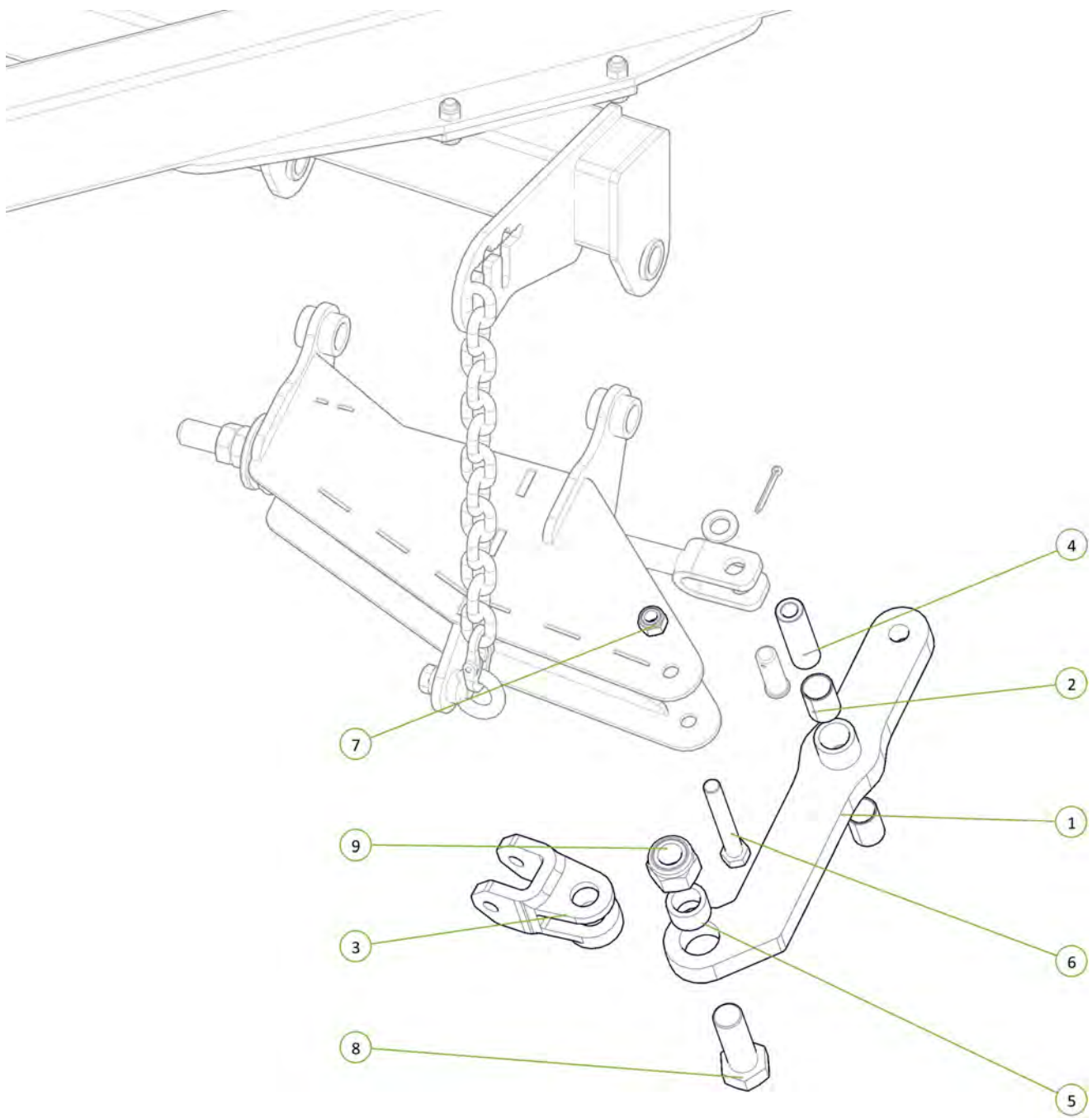

| Item No. | Description                  | Number         | Qty |
|----------|------------------------------|----------------|-----|
| 1        | Module Tension Arm           | 0810-104F      | 1   |
| 2        | 35 ID x 50mm DU Bush         | 0113-MB 3550DU | 2   |
| 3        | Forged Clevis 21mm Bolt Hole | 0801-FC21      | 1   |
| 4        | Module Pivot Arm Bush        | 0801-10-110    | 1   |
| 5        | Stainless Steel Wear Bush    | 1501-365033-SS | 1   |
| 6        | M20 x 150 grade 8.8 ZP Bolt  | 0211-20150     | 1   |
| 7        | Nyloc Nut M20                | 0221-NYL20     | 1   |
| 8        | M36 x 105 grade 8.8 zp Bolt  | 0211-36105     | 1   |
| 9        | Nyloc Nut M36                | 0221-NYL36     | 1   |

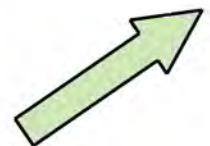

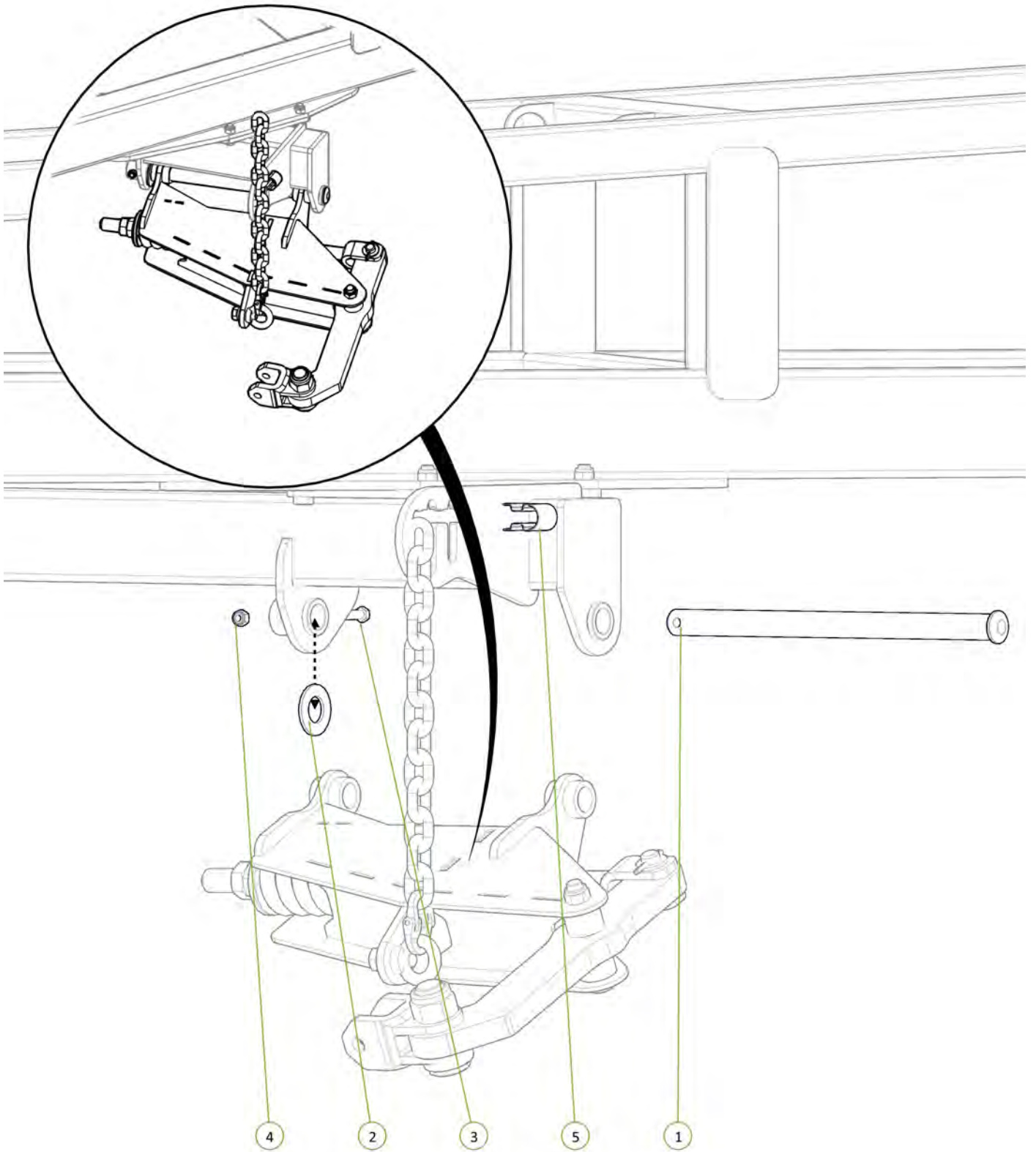

| Item No. | Description                    | Number      | Qty |
|----------|--------------------------------|-------------|-----|
| 1        | Chain Mount Pivot Pin          | 0801-10-51  | 1   |
| 2        | Washer High Tensile 1 3/8"     | 0232-HT13-8 | 1   |
| 3        | M12 x 65 grade 8.8 ZP Bolt     | 0211-1265   | 1   |
| 4        | Nyloc Nut M12                  | 0221-NYL12  | 1   |
| 5        | Height Adjustor Retaining Clip | 0801-KE014  | 1   |





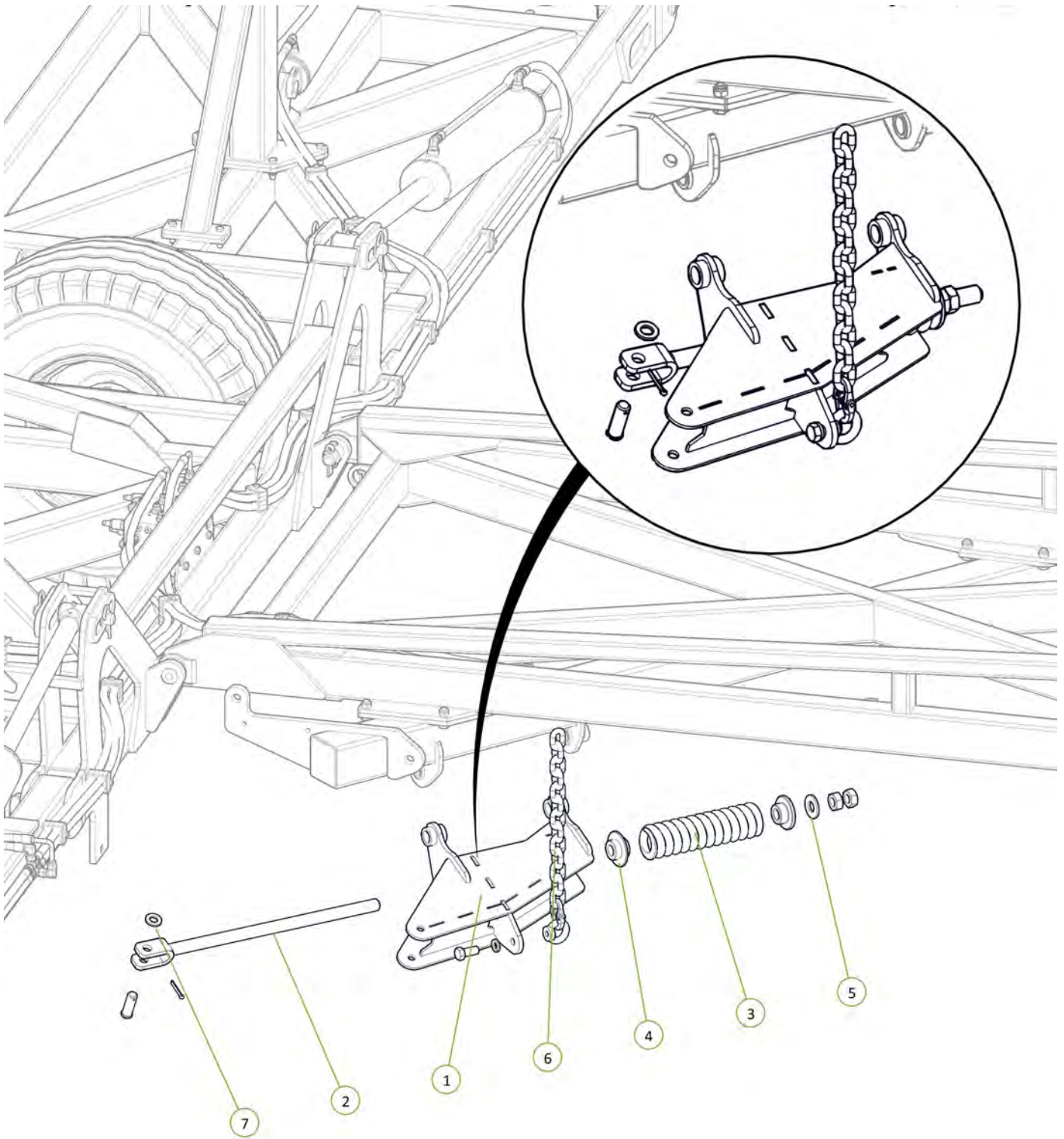

| Item No. | Description                     | Number       | Qty |
|----------|---------------------------------|--------------|-----|
| 1        | Front Module Tension Body       | 0810-103F    | 1   |
| 2        | Module Tension Rod Assembly     | 0810-105A    | 1   |
| 3        | 20mm Compression Spring         | 0801-XK9261S | 1   |
| 4        | Rigid Spring Locator            | 0801-10-S2L  | 1   |
| 5        | Washer High Tensile 1 1/4"      | 0232-HT11-4  | 1   |
| 6        | Height Adjusting Chain Assembly | 0801-20MCA   | 1   |
| 7        | Washer Flat M24                 | 0231-F24     | 1   |





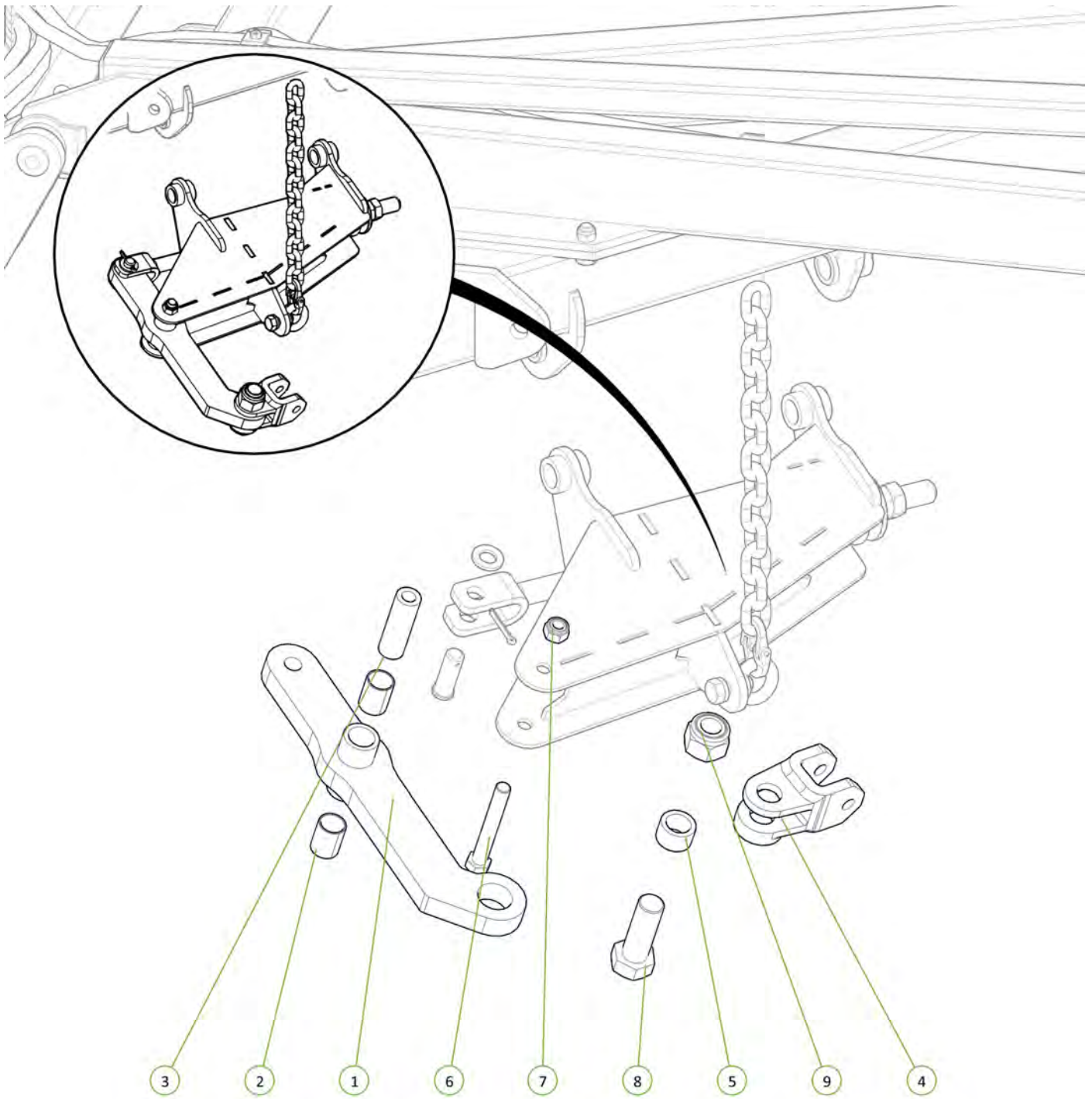

| Item No. | Description                  | Number         | Qty |
|----------|------------------------------|----------------|-----|
| 1        | Module Tension Arm           | 0810-104F      | 1   |
| 2        | 35 ID x 50mm DU Bush         | 0113-MB 3550DU | 2   |
| 3        | Module Pivot Arm Bush        | 0801-10-110    | 1   |
| 4        | Forged Clevis 21mm Bolt Hole | 0801-FC21      | 1   |
| 5        | Stainless Steel Wear Bush    | 1501-365033-SS | 1   |
| 6        | M20 x 150 grade 8.8 ZP Bolt  | 0211-20150     | 1   |
| 7        | Nyloc Nut M20                | 0221-NYL20     | 1   |
| 8        | M36 x 105 grade 8.8 zp Bolt  | 0211-36105     | 1   |
| 9        | Nyloc Nut M36                | 0221-NYL36     | 1   |

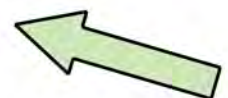

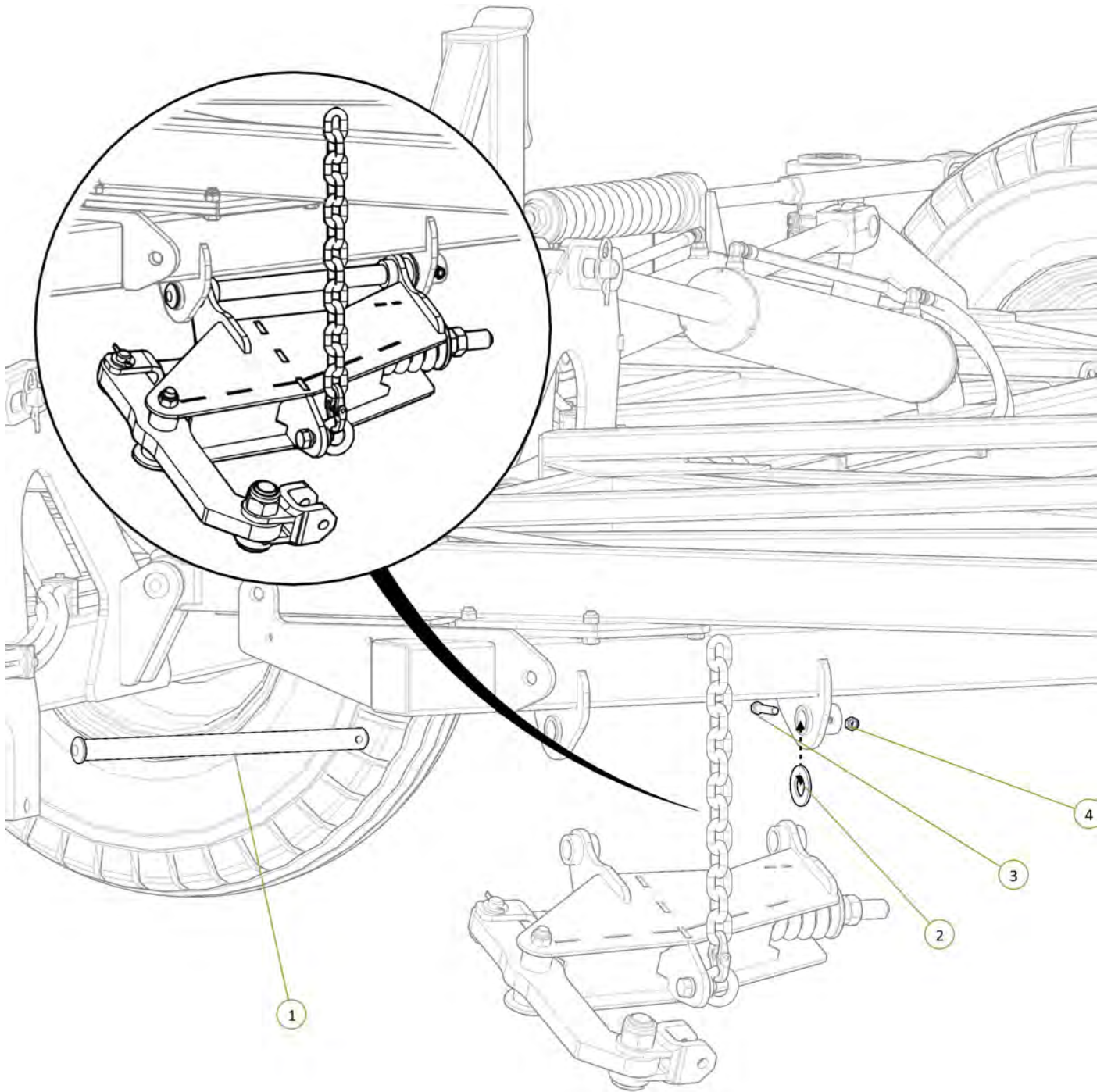

| Item No. | Description                | Number      | Qty |
|----------|----------------------------|-------------|-----|
| 1        | Chain Mount Pivot Pin      | 0801-10-51  | 1   |
| 2        | Washer High Tensile 1 3/8" | 0232-HT13-8 | 1   |
| 3        | M12 x 65 grade 8.8 ZP Bolt | 0211-1265   | 1   |
| 4        | Nyloc Nut M12              | 0221-NYL12  | 1   |



| Item No. | Description                    | Number        | Qty |
|----------|--------------------------------|---------------|-----|
| 1        | 30' Module Lift Plate          | 0810-106      | 1   |
| 2        | Clevis Pin 25mm x 75mm         | 0801-KE0307-1 | 1   |
| 3        | Height Adjustor Retaining Clip | 0801-KE014    | 1   |
| 4        | Washer Flat M24                | 0231-F24      | 1   |
| 5        | Cotter Pin M5 x 50             | 0261-PINC550  | 1   |

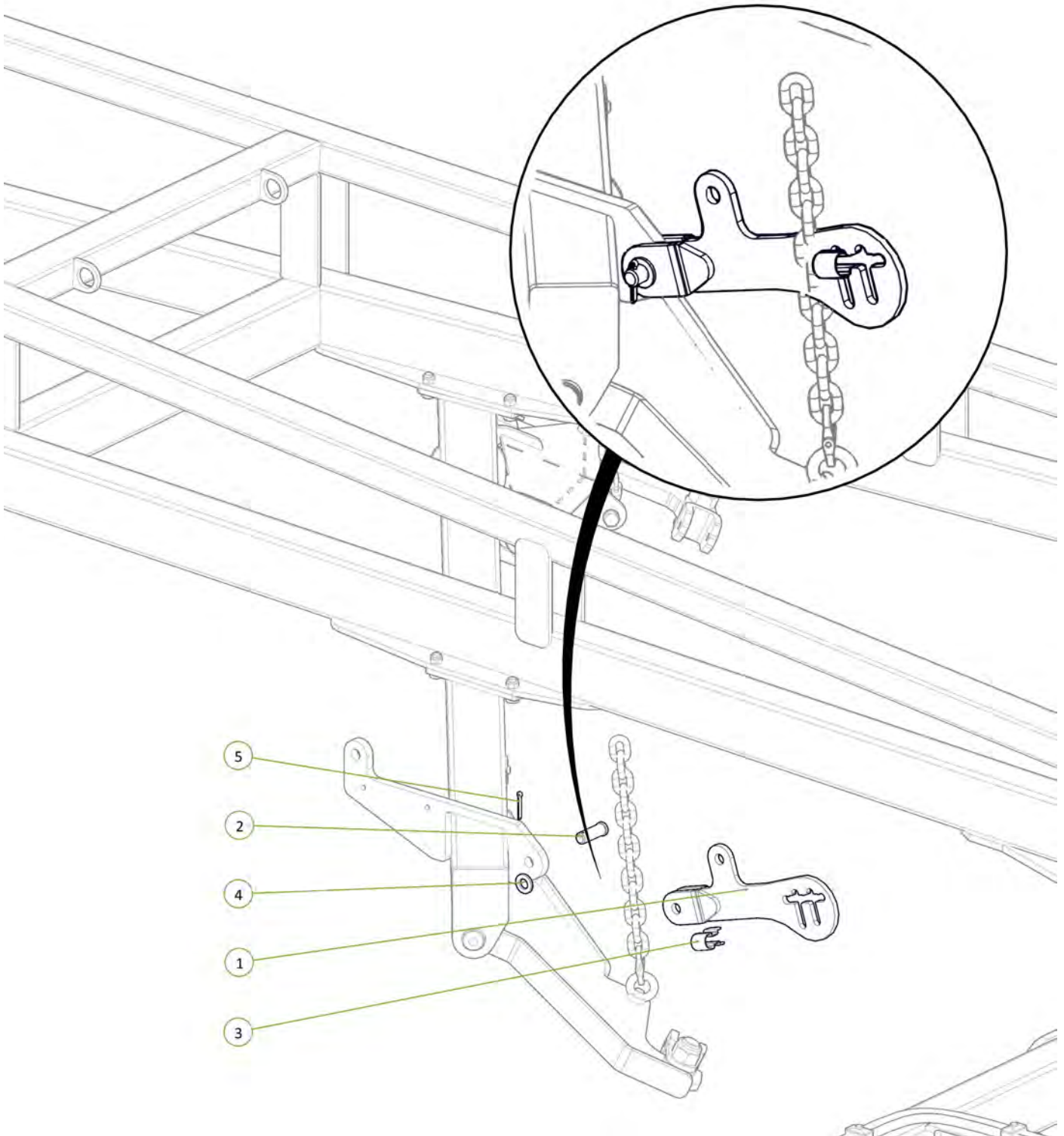
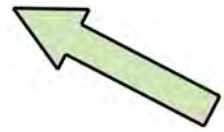



| Item No. | Description                                       | Number     | Qty |
|----------|---|------------|-----|
| 1        | 2.5" Bore x 6" Stroke 1.5" Rod Side Port Cylinder | 0311-256SP | 1   |

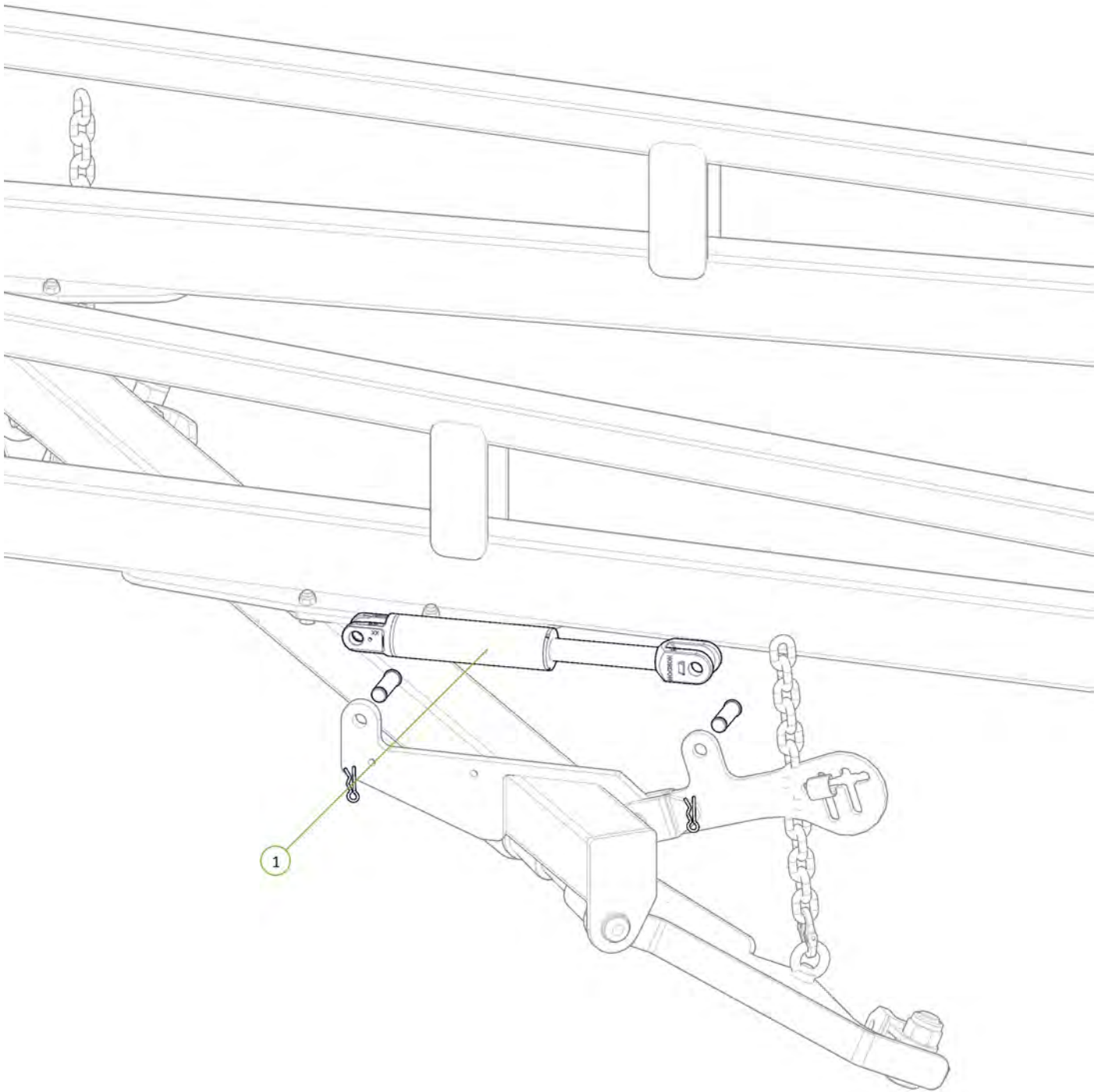



| Item No. | Description                                 | Number        | Qty |
|----------|---|---------------|-----|
| 1        | 3/4" JIC Male 3/4" UN O Ring Male 45° Elbow | 0323-S88-1212 | 2   |

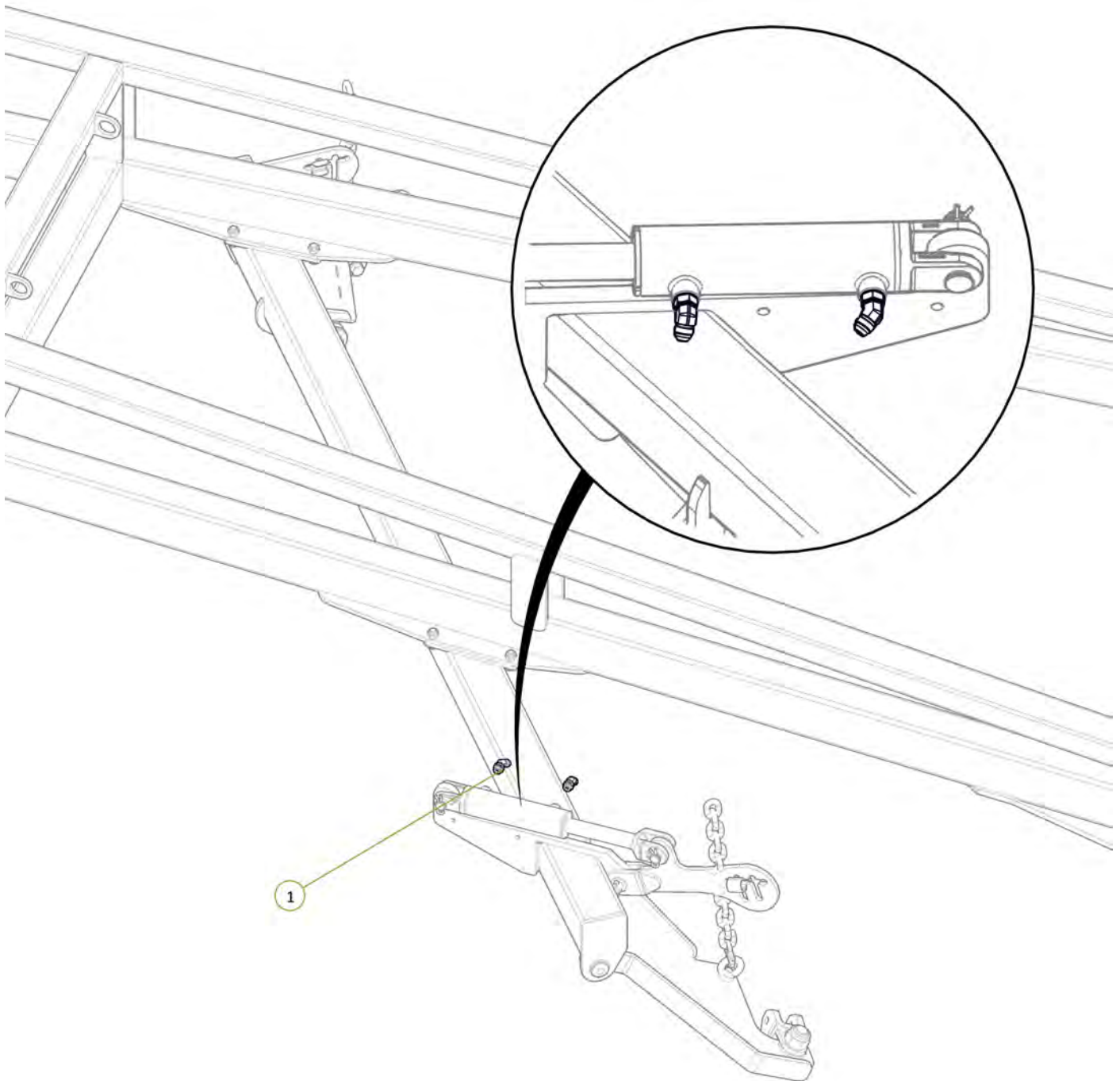

| Item No. | Description   | Number  | Qty |
|----------|---|---------|-----|
| 1        | ME2 Port to Front Module Lift Cylinder Extend Port  | PH40-14 | 1   |
| 2        | MR2 Port to Front Module Lift Cylinder Retract Port | PH40-15 | 1   |

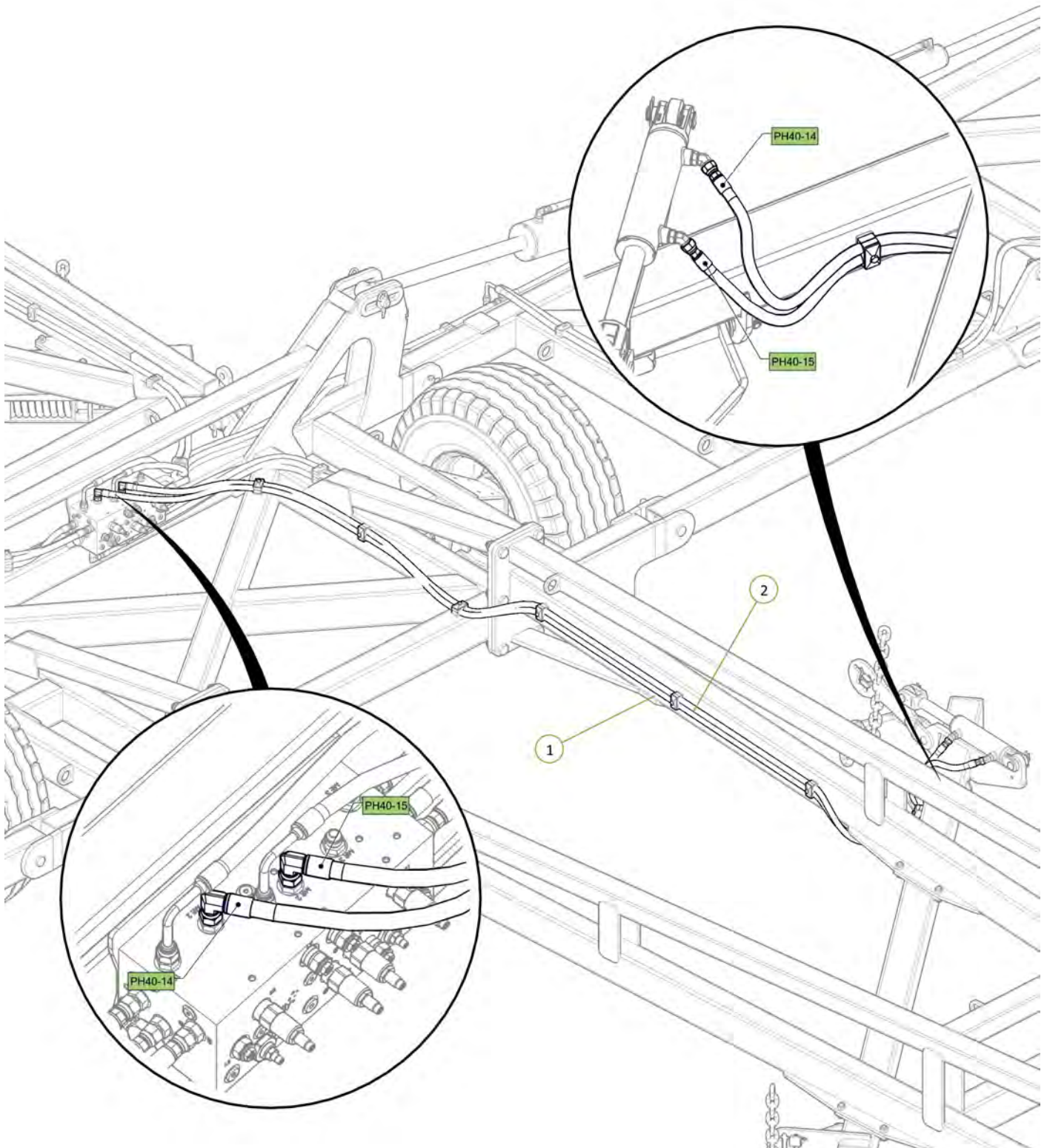



| Item No. | Description                    | Number        | Qty |
|----------|--------------------------------|---------------|-----|
| 1        | 30' Module Lift Plate          | 0810-106      | 1   |
| 2        | Clevis Pin 25mm x 75mm         | 0801-KE0307-1 | 1   |
| 3        | Washer Flat M24                | 0231-F24      | 1   |
| 4        | Height Adjustor Retaining Clip | 0801-KE014    | 1   |
| 5        | Cotter Pin M5 x 50             | 0261-PINC550  | 1   |

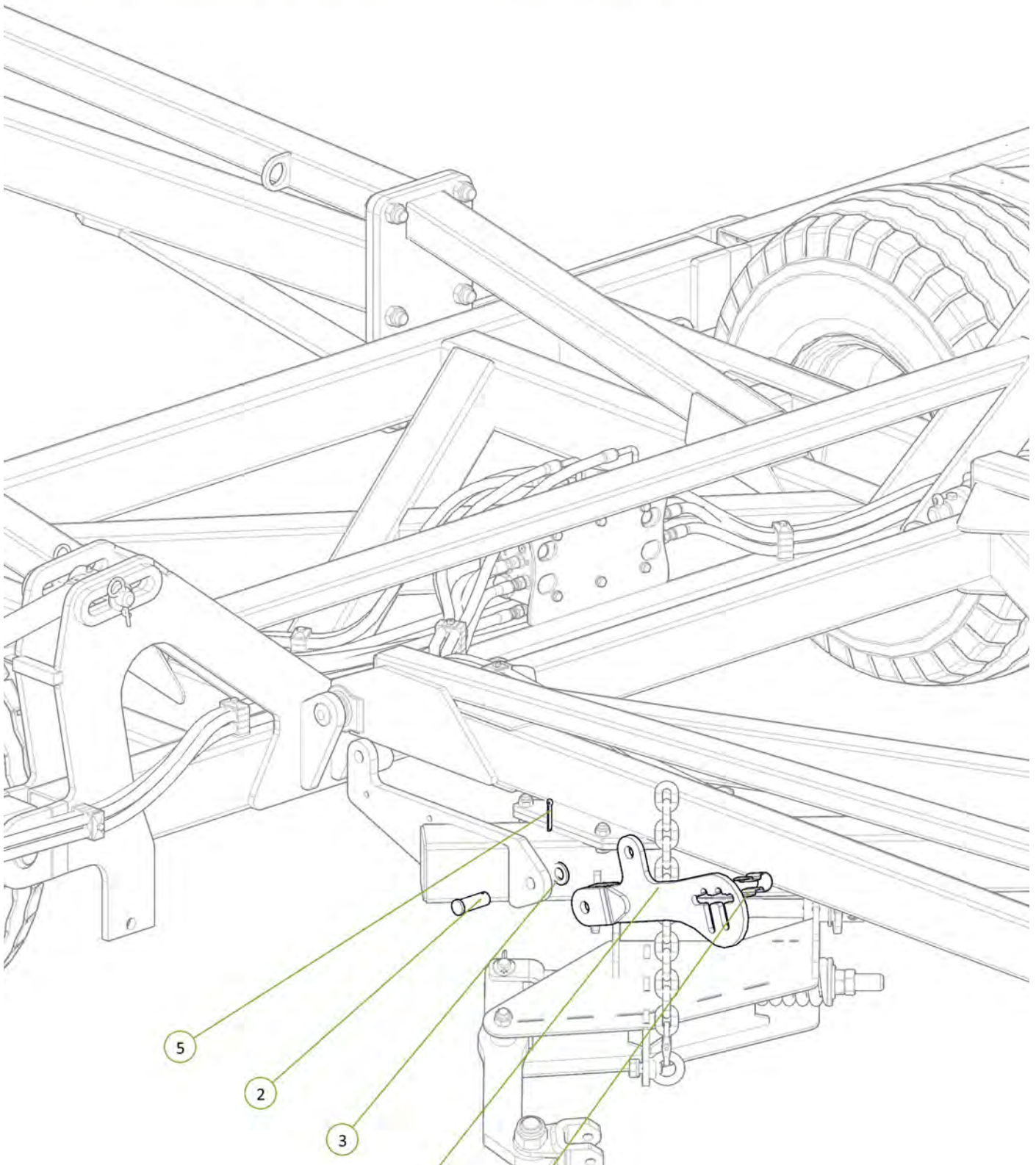

| Item No. | Description                                       | Number     | Qty |
|----------|---|------------|-----|
| 1        | 2.5" Bore x 6" Stroke 1.5" Rod Side Port Cylinder | 0311-256SP | 1   |

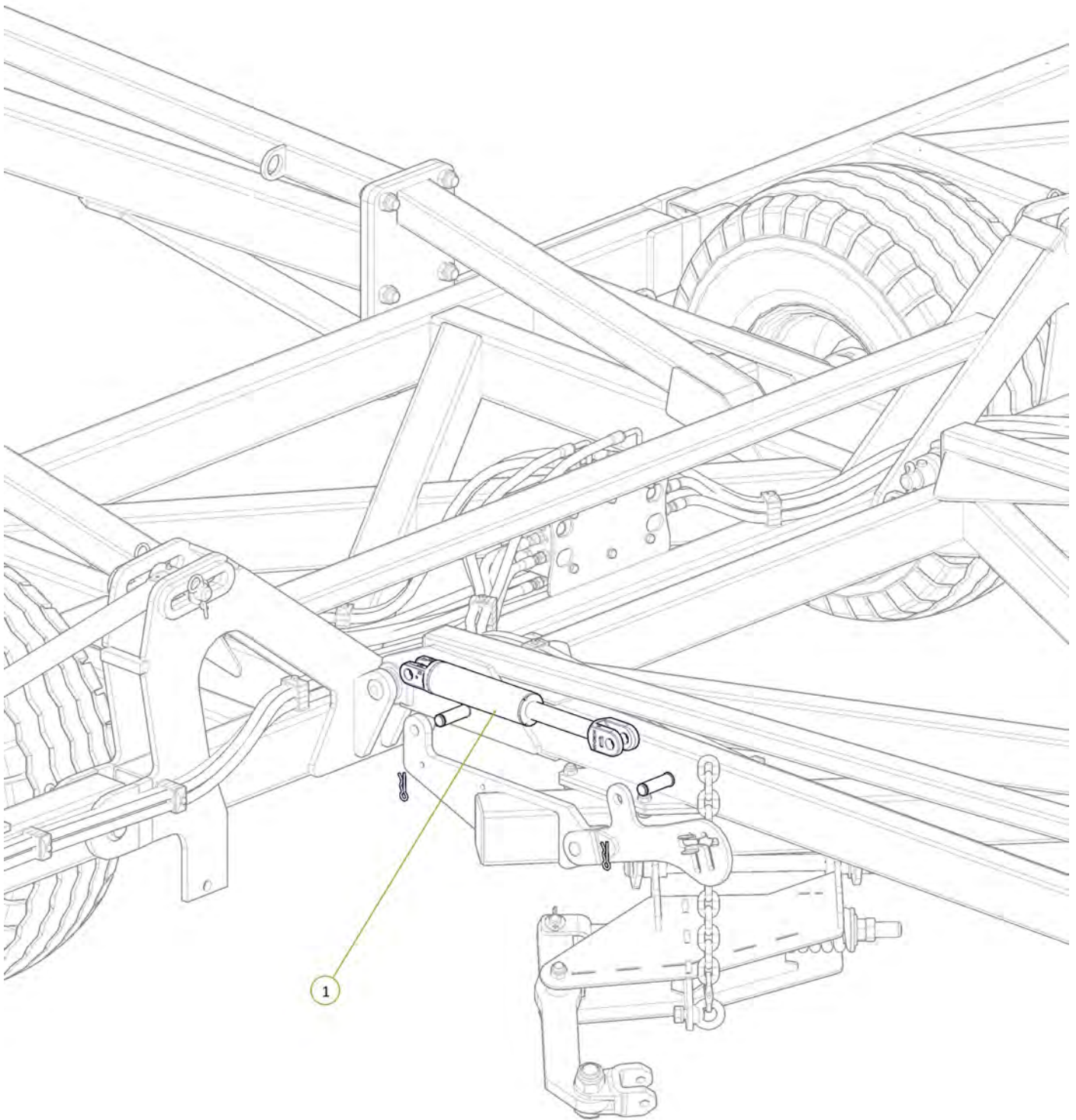
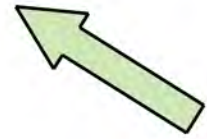



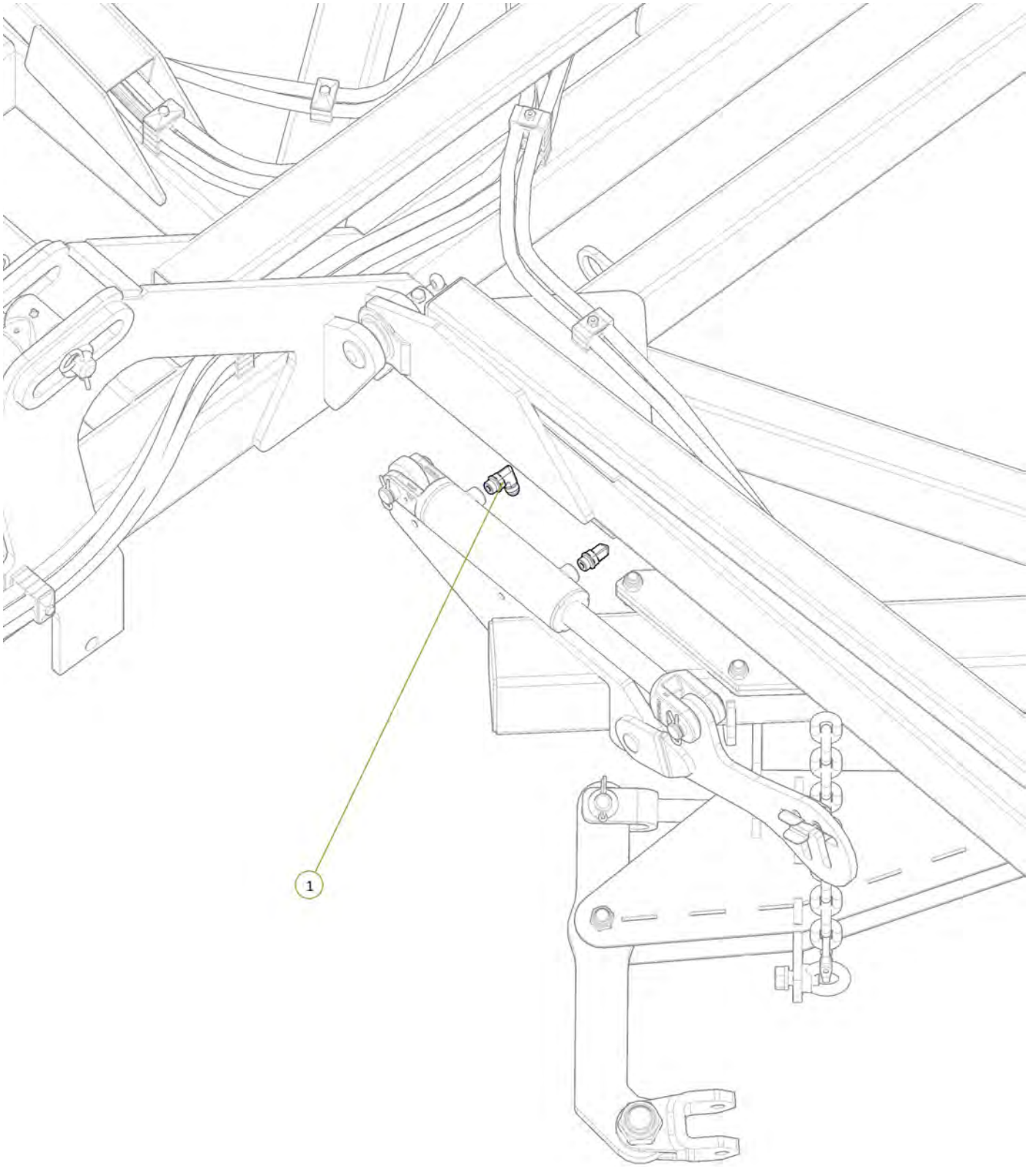

| Item No. | Description                                 | Number        | Qty |
|----------|---|---------------|-----|
| 1        | 3/4" JIC Male 3/4" UN O Ring Male 90° Elbow | 0323-S91-1212 | 2   |



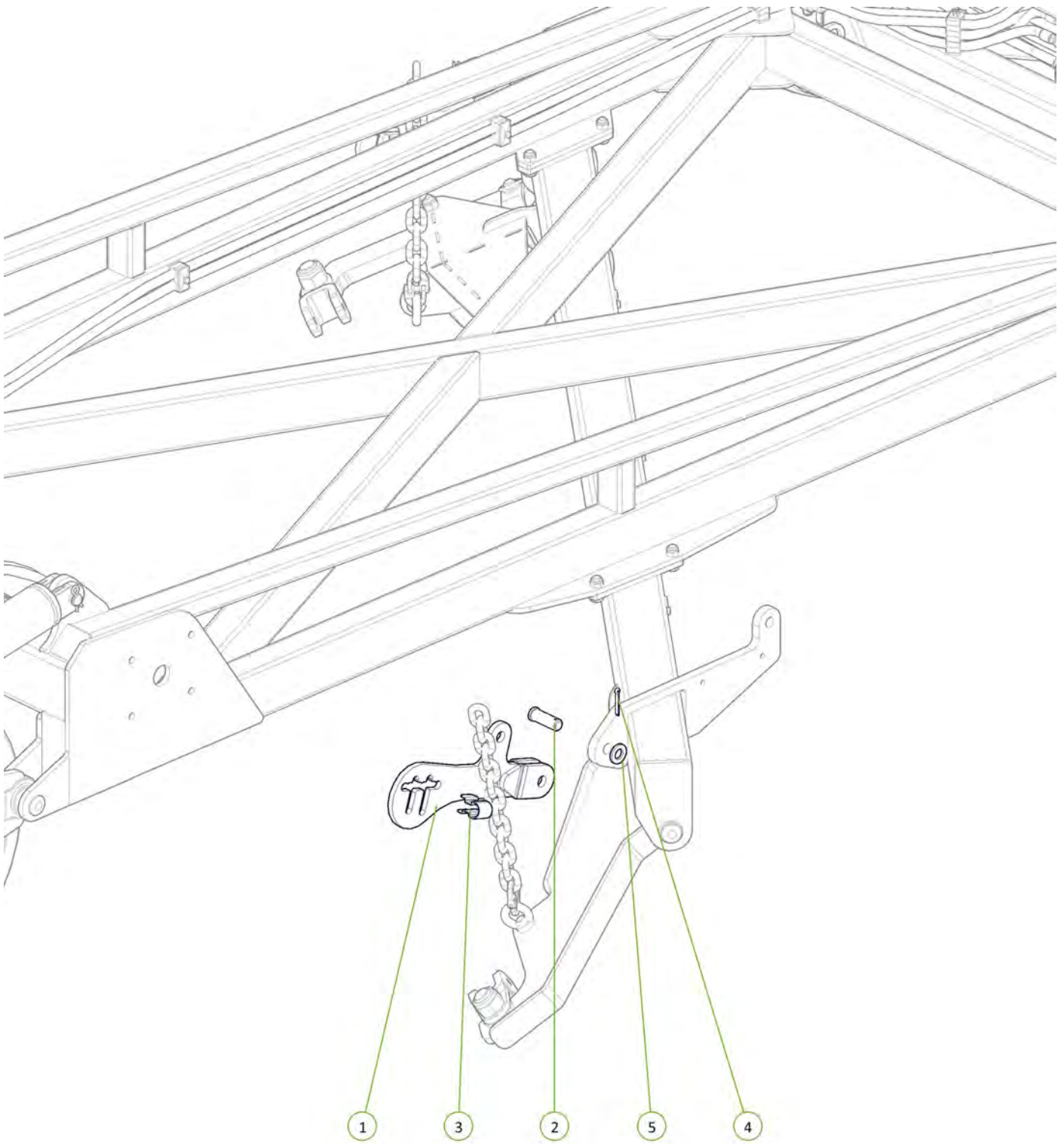

| Item No. | Description                    | Number        | Qty |
|----------|--------------------------------|---------------|-----|
| 1        | 30' Module Lift Plate          | 0810-106      | 1   |
| 2        | Clevis Pin 25mm x 75mm         | 0801-KE0307-1 | 1   |
| 3        | Height Adjustor Retaining Clip | 0801-KE014    | 1   |
| 4        | Cotter Pin M5 x 50             | 0261-PINC550  | 1   |
| 5        | Washer Flat M24                | 0231-F24      | 1   |

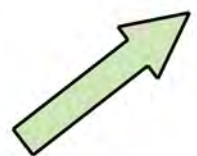

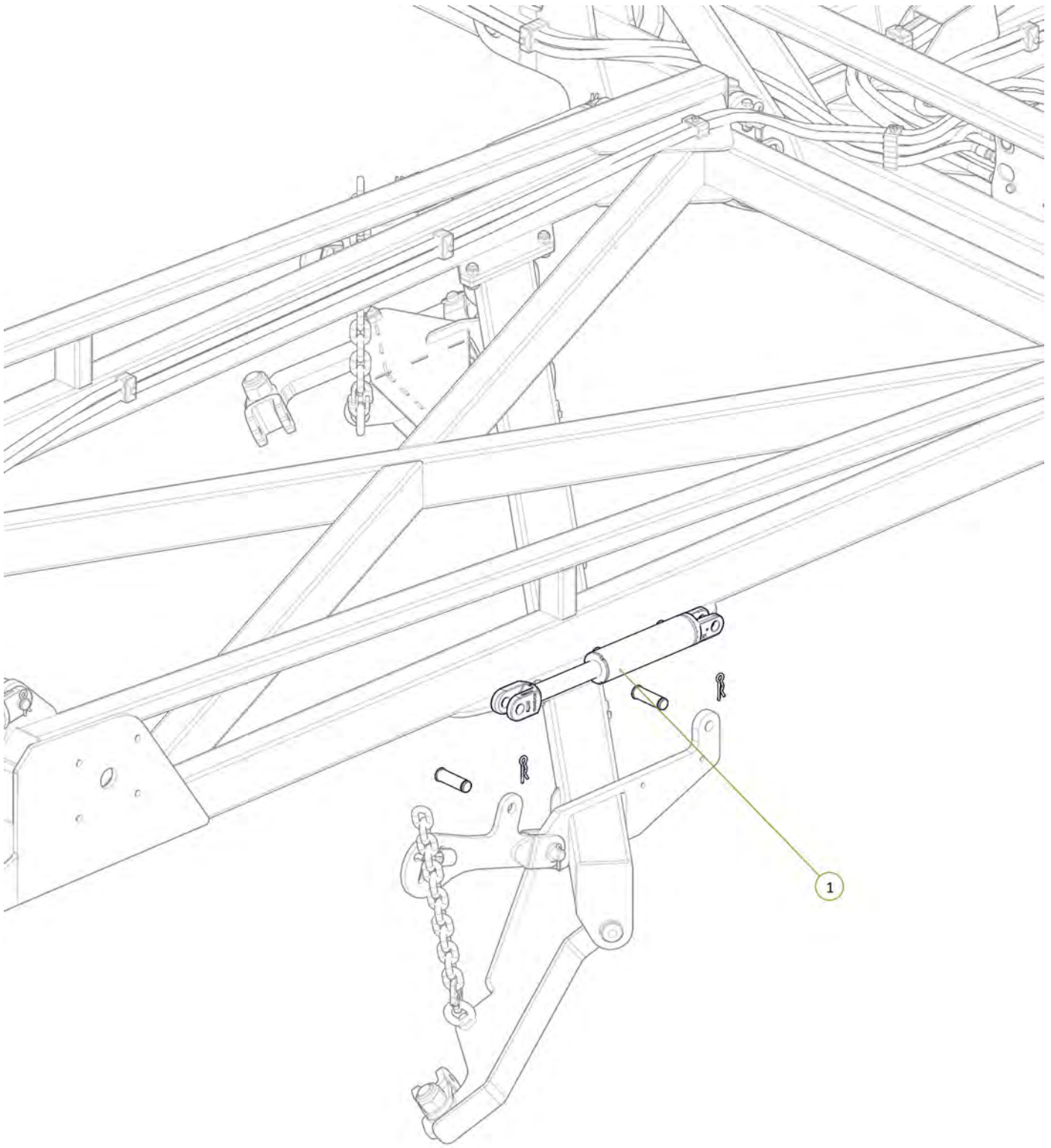

| Item No. | Description                                       | Number     | Qty |
|----------|---|------------|-----|
| 1        | 2.5" Bore x 6" Stroke 1.5" Rod Side Port Cylinder | 0311-256SP | 1   |

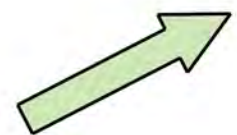



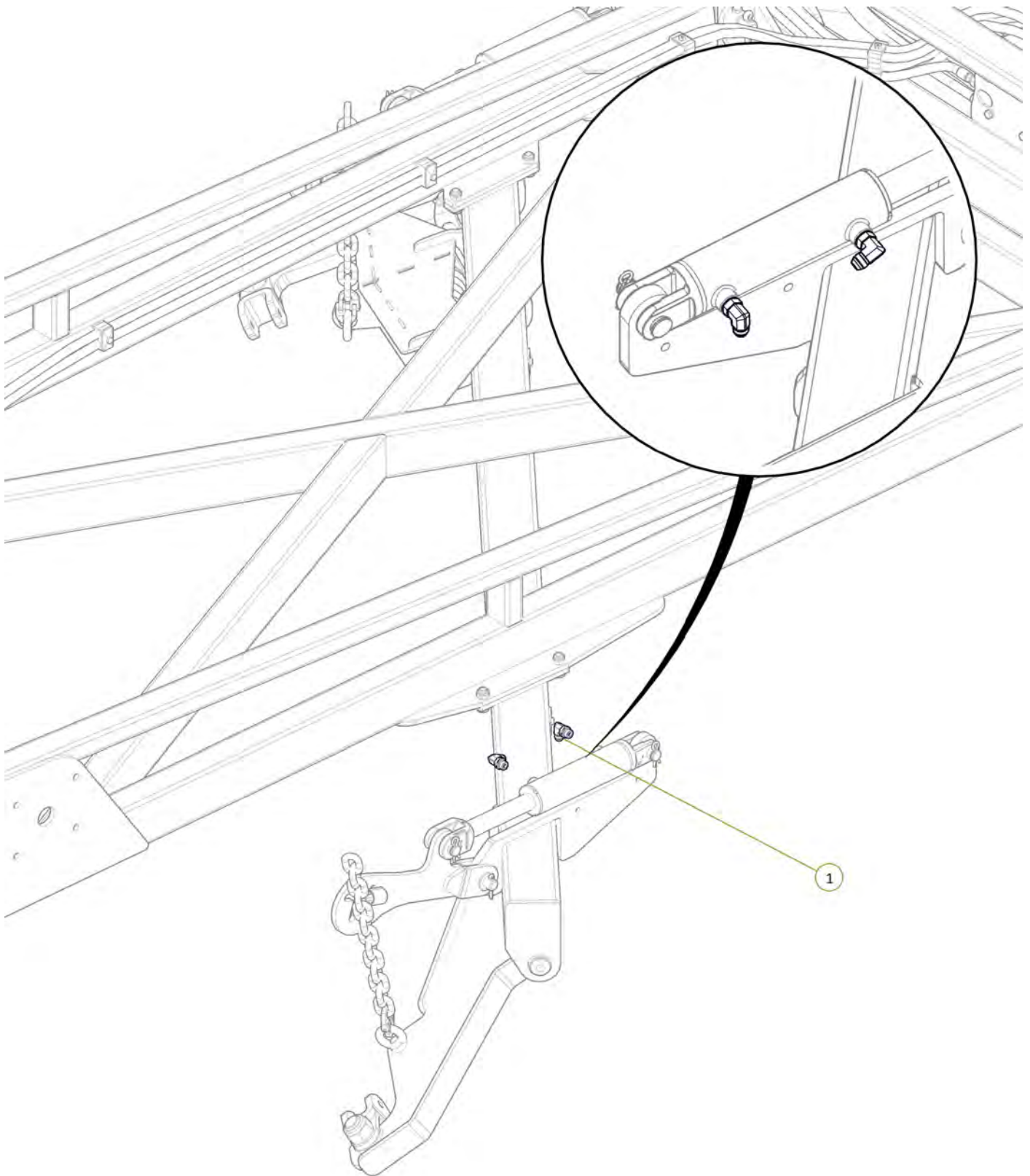

| Item No. | Description                                 | Number        | Qty |
|----------|---|---------------|-----|
| 1        | 3/4" JIC Male 3/4" UN O Ring Male 90° Elbow | 0323-S91-1212 | 2   |

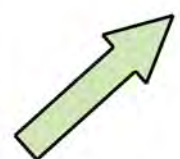

| Item No. | Description   | Number          | Qty |
|----------|---|-----------------|-----|
| 1        | ME3 Port to Rear Module Extend Tee                    | PH40-24         | 1   |
| 2        | MR3 Port to Rear Module Retract Tee                   | PH40-25         | 1   |
| 3        | 3/4" JIC Male Tee 3/4" JIC Male Tee 3/4" JIC Male Tee | 0324-S19-121212 | 2   |

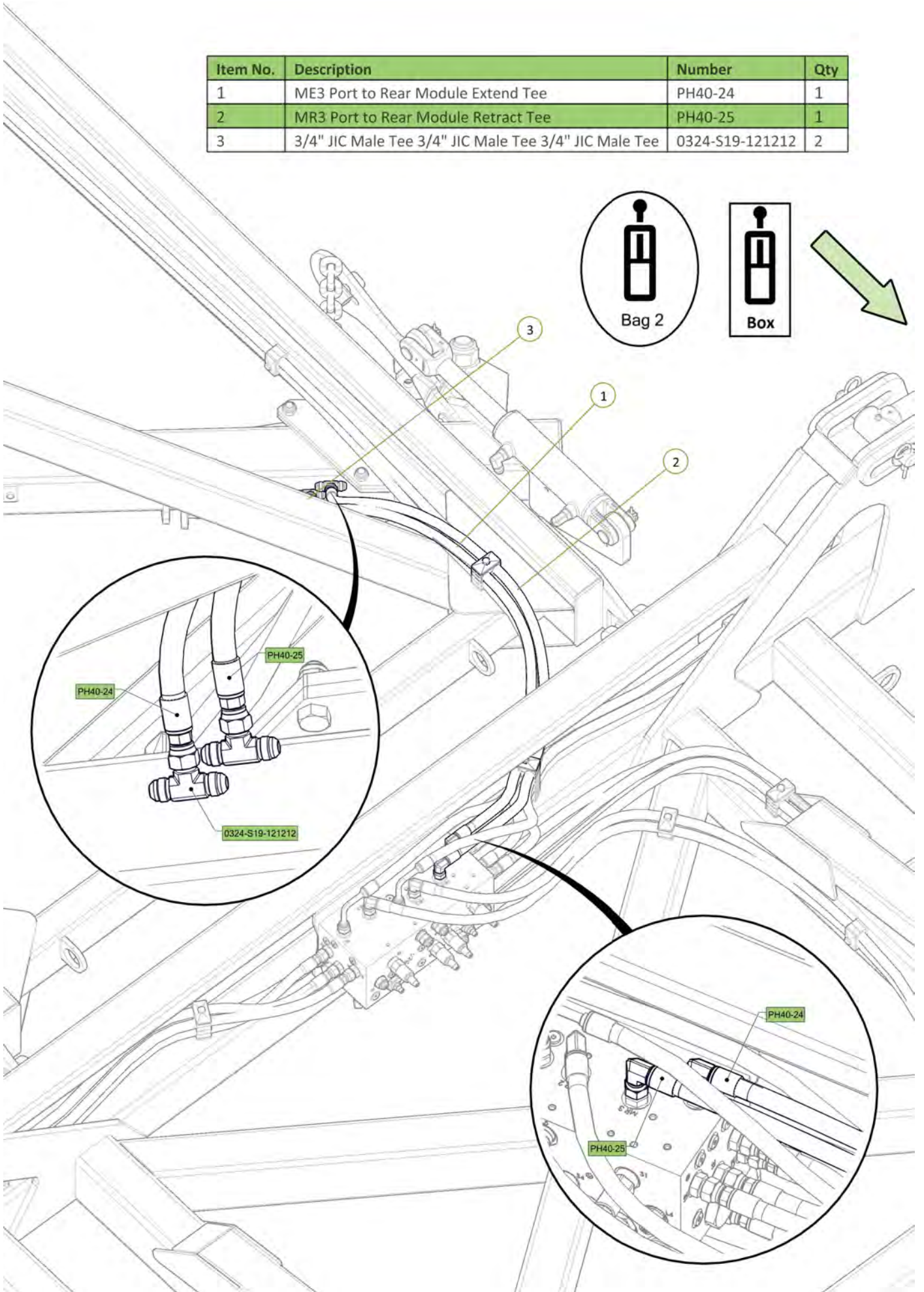



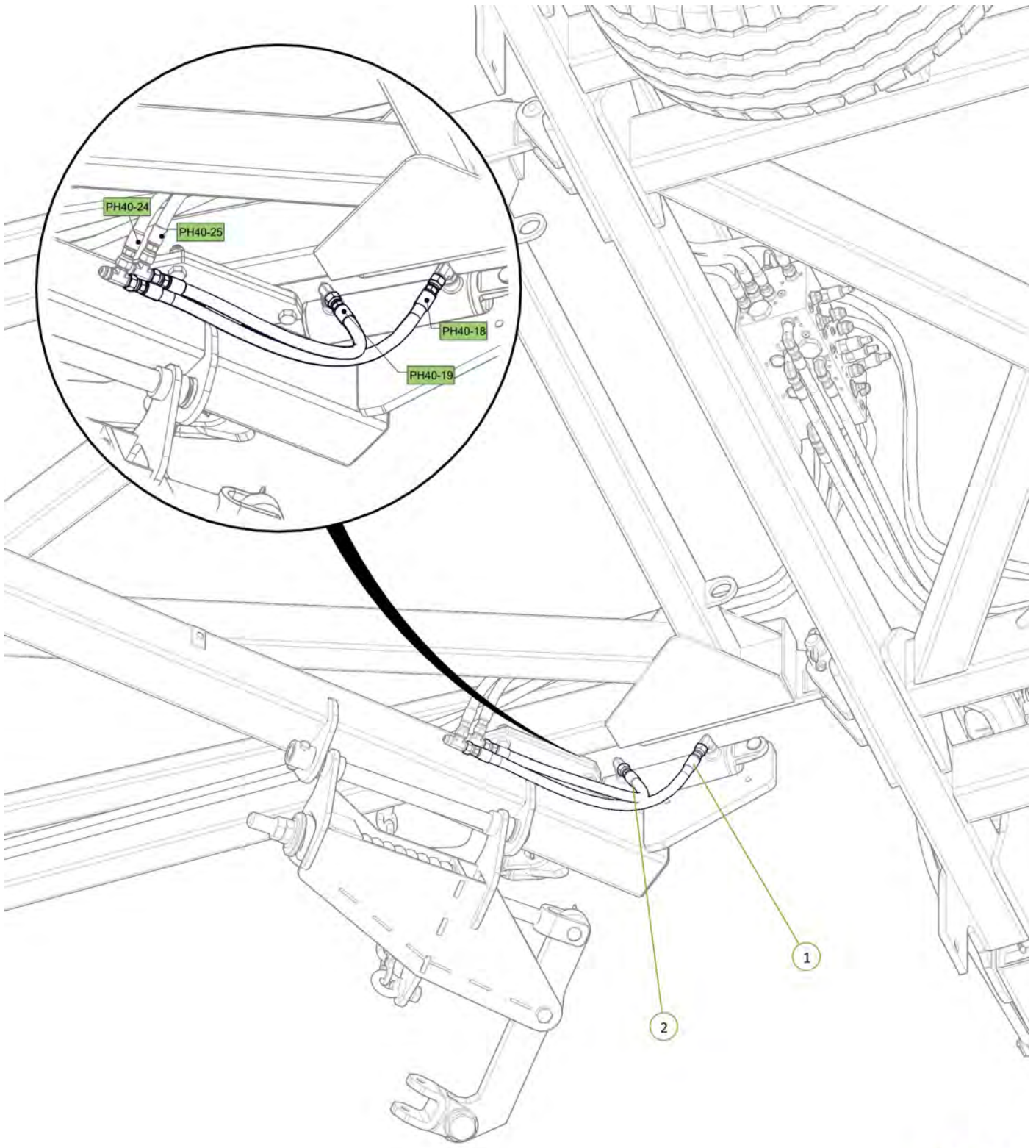

| Item No. | Description   | Number  | Qty |
|----------|---|---------|-----|
| 1        | Rear Module Extend Tee to LH Module Lift Cylinder Extend Port   | PH40-18 | 1   |
| 2        | Rear Module Retract Tee to LH Module Lift Cylinder Retract Port | PH40-19 | 1   |





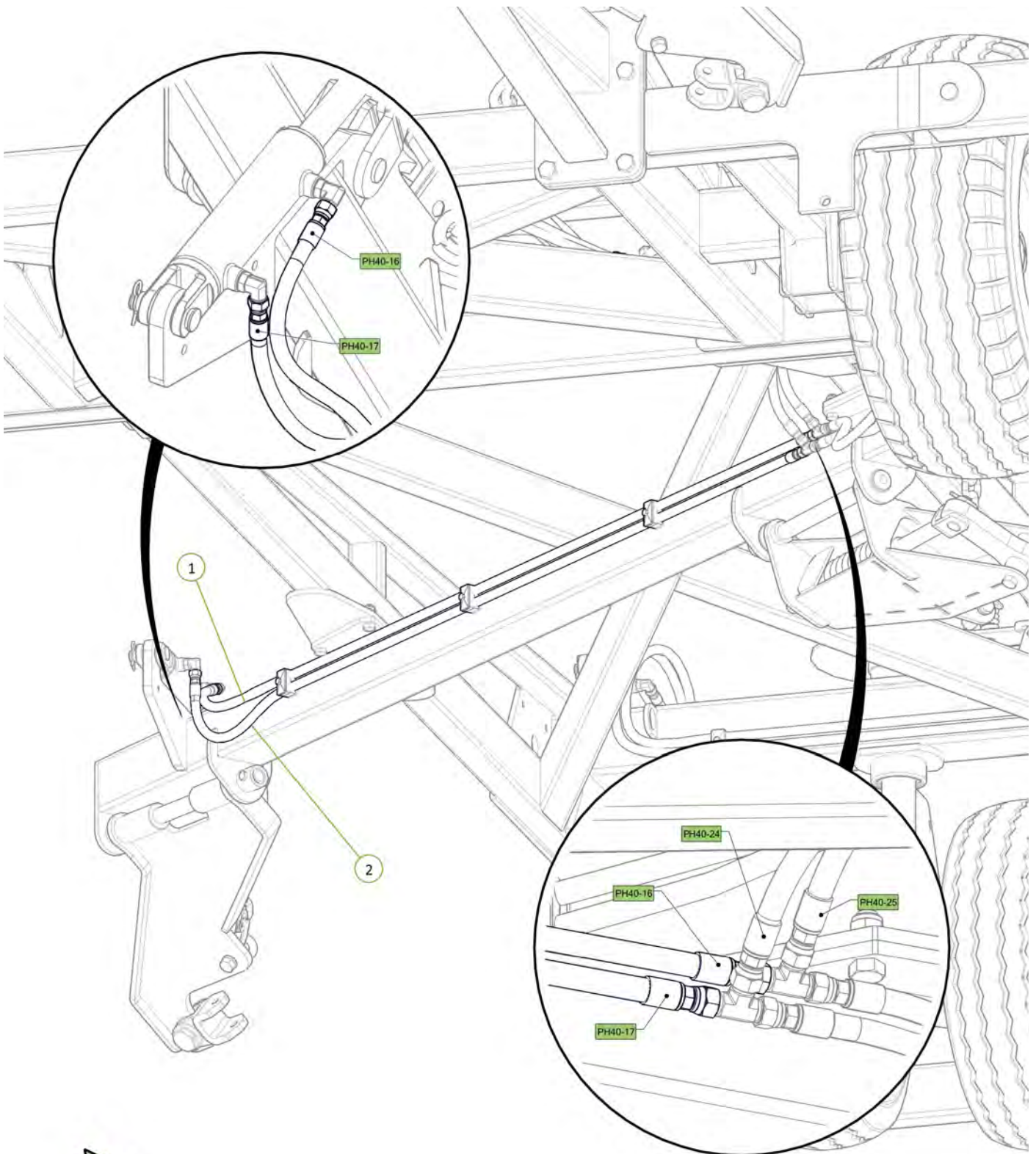

| Item No. | Description   | Number  | Qty |
|----------|---|---------|-----|
| 1        | Rear Module Retract Tee to Right Rear Module Lift Cylinder Retract Port | PH40-16 | 1   |
| 2        | Rear Module Extend Tee to Right Rear Module Lift Cylinder Extend Port   | PH40-17 | 1   |



| Item No. | Description                      | Number        | Qty |
|----------|----------------------------------|---------------|-----|
| 1        | 40' Chain Carrier Beam           | 0810-17-40    | 1   |
| 2        | Chain Carrier Mount Plate        | 0800-139.1    | 2   |
| 3        | U-Bolt M16 x 112 Deep x 104 Wide | 0271-16112104 | 4   |
| 4        | U-Bolt M16 x 160 Deep x 127 Wide | 0271-16160127 | 4   |
| 5        | Washer Flat M16                  | 0231-F16      | 16  |
| 6        | Nyloc Nut M16                    | 0221-NYL16    | 16  |

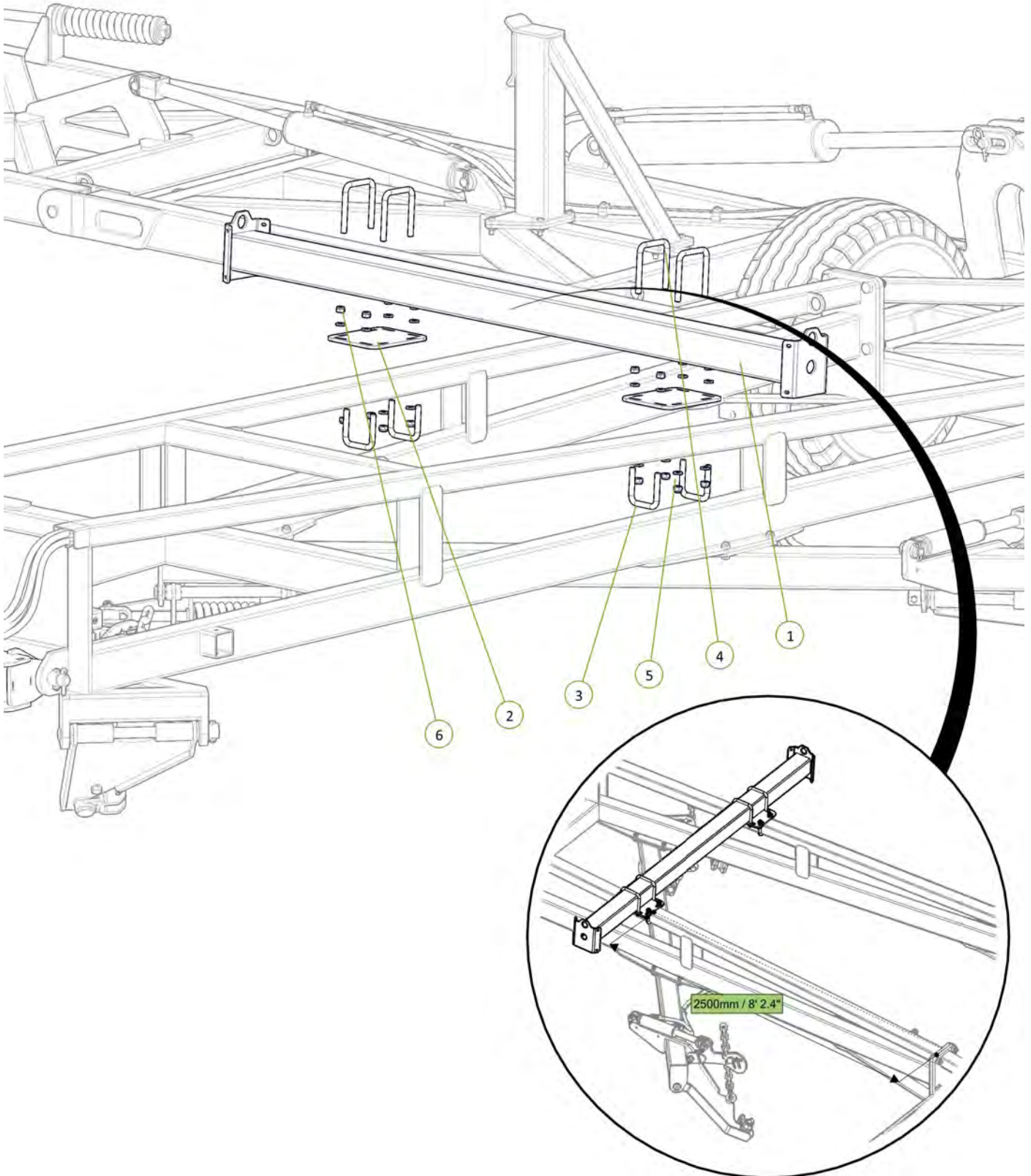
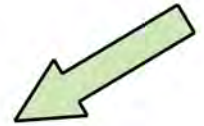



| Item No. | Description               | Number      | Qty |
|----------|---------------------------|-------------|-----|
| 1        | Chain Carrier Bolt on End | 0810-17L    | 2   |
| 2        | M12 x 40 Coach Head Bolt  | 0215-CH1240 | 8   |
| 3        | Washer Flat M12           | 0231-F12    | 8   |
| 4        | Nyloc Nut M12             | 0221-NYL12  | 8   |

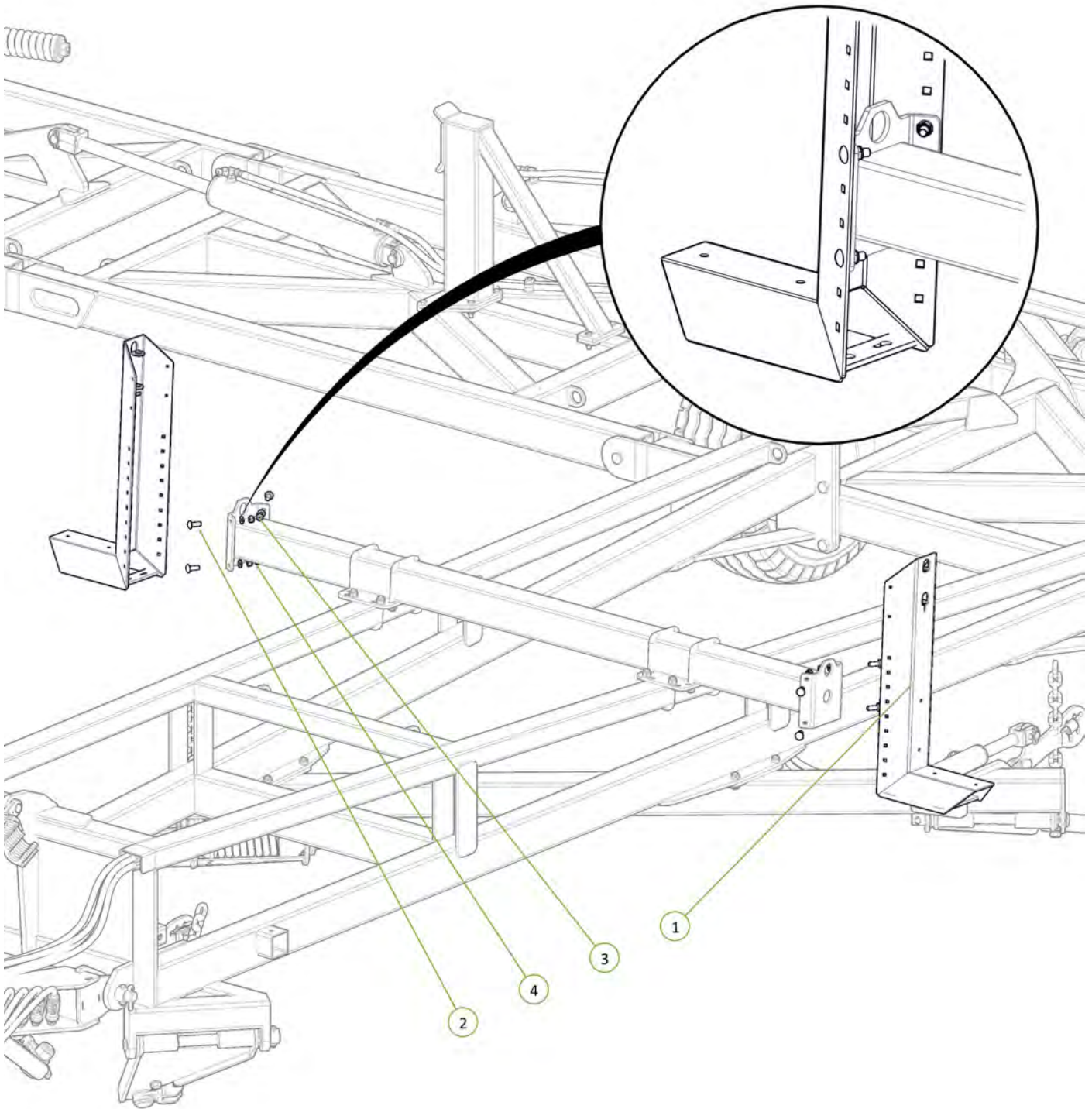
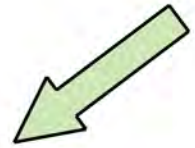



| Item No. | Description                      | Number        | Qty |
|----------|----------------------------------|---------------|-----|
| 1        | 40' Chain Carrier Beam           | 0810-17-40    | 1   |
| 2        | Chain Carrier Mount Plate        | 0800-139.1    | 2   |
| 3        | U-Bolt M16 x 85 Deep X 77 Wide   | 0271-168577   | 4   |
| 4        | U-Bolt M16 x 160 Deep x 127 Wide | 0271-16160127 | 4   |
| 5        | Washer Flat M16                  | 0231-F16      | 16  |
| 6        | Nyloc Nut M16                    | 0221-NYL16    | 16  |

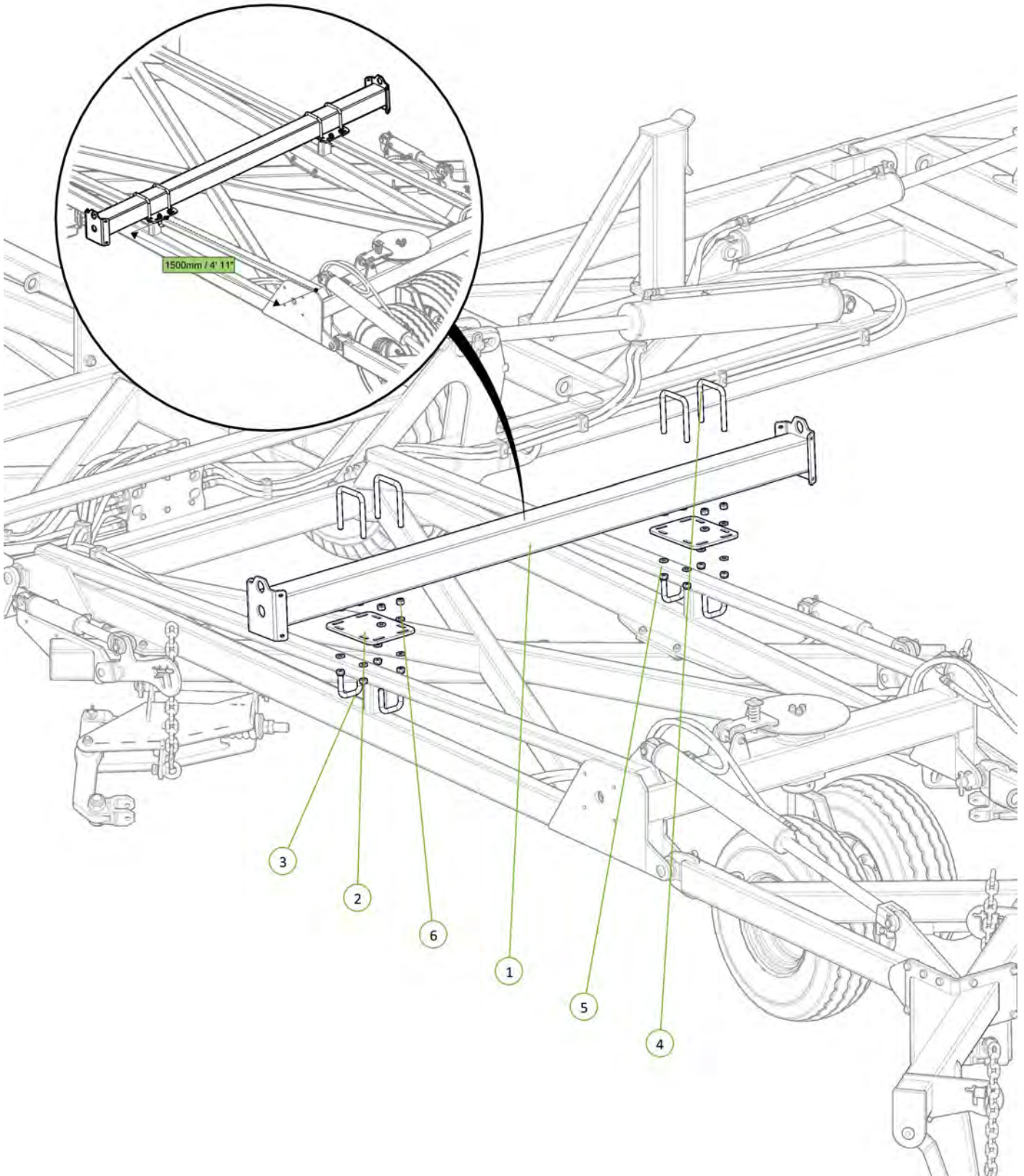

| Item No. | Description               | Number      | Qty |
|----------|---------------------------|-------------|-----|
| 1        | Chain Carrier Bolt on End | 0810-17L    | 2   |
| 2        | M12 x 40 Coach Head Bolt  | 0215-CH1240 | 8   |
| 3        | Washer Flat M12           | 0231-F12    | 8   |
| 4        | Nyloc Nut M12             | 0221-NYL12  | 8   |

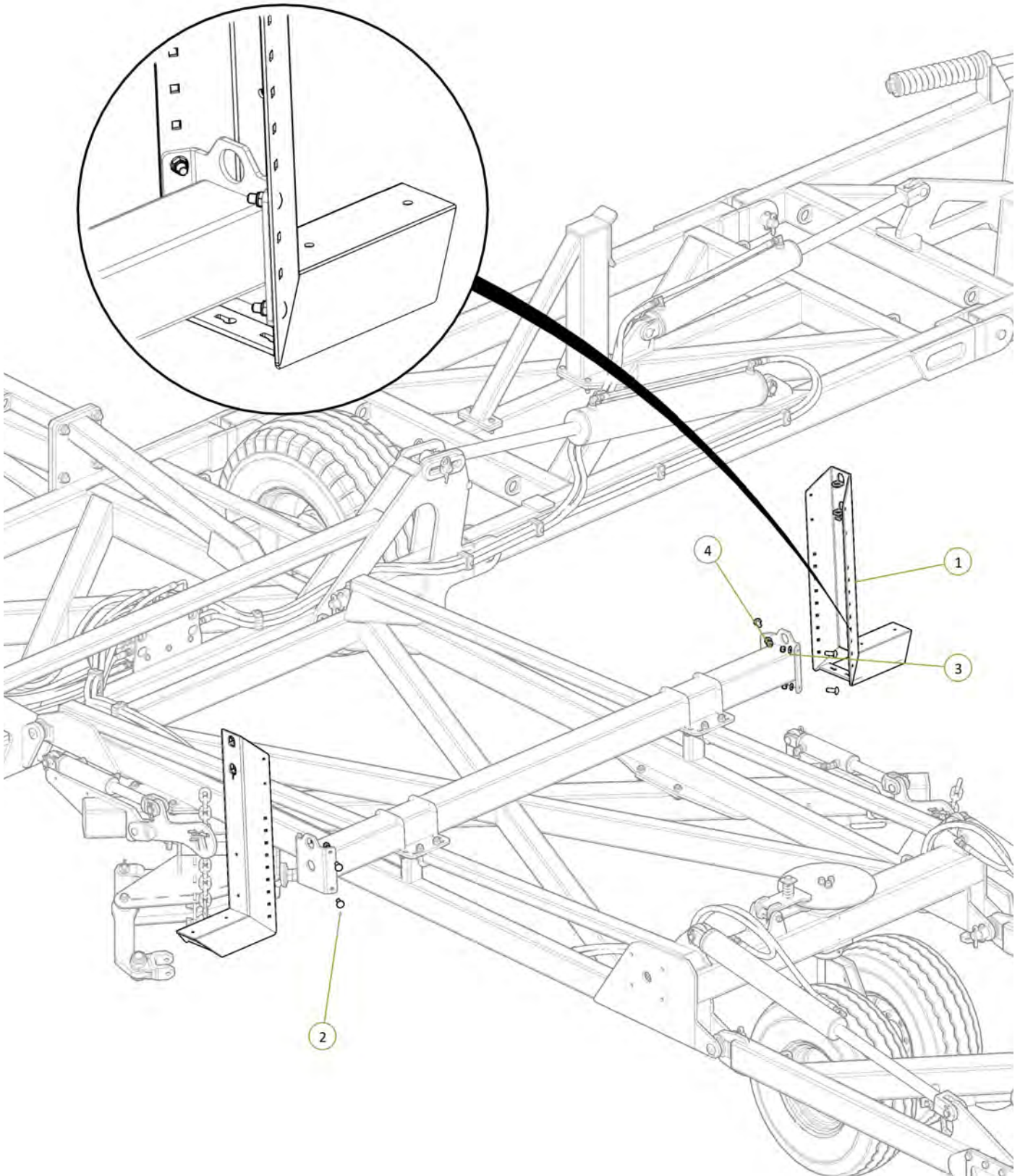
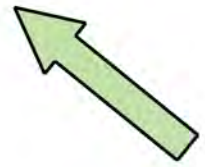



| Item No. | Description                | Number     | Qty |
|----------|----------------------------|------------|-----|
| 1        | Outrigger                  | 0810-109   | 2   |
| 2        | M16 x 50 grade 8.8 zp Bolt | 0211-1650  | 8   |
| 3        | Nyloc Nut M16              | 0221-NYL16 | 8   |

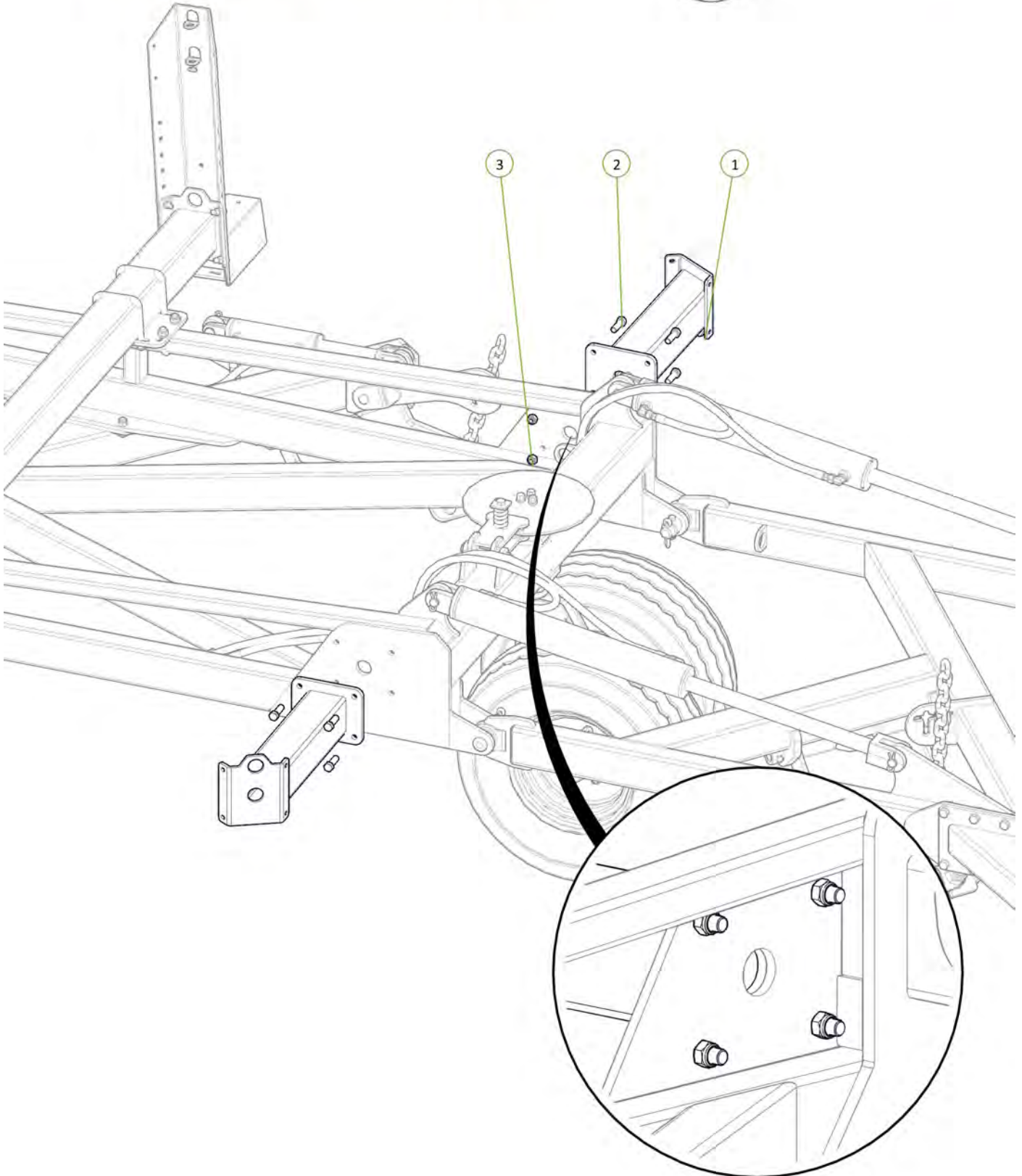



| Item No. | Description               | Number      | Qty |
|----------|---------------------------|-------------|-----|
| 1        | Chain Carrier Bolt on End | 0810-17L    | 2   |
| 2        | M12 x 40 Coach Head Bolt  | 0215-CH1240 | 8   |
| 3        | Washer Flat M12           | 0231-F12    | 8   |
| 4        | Nyloc Nut M12             | 0221-NYL12  | 8   |

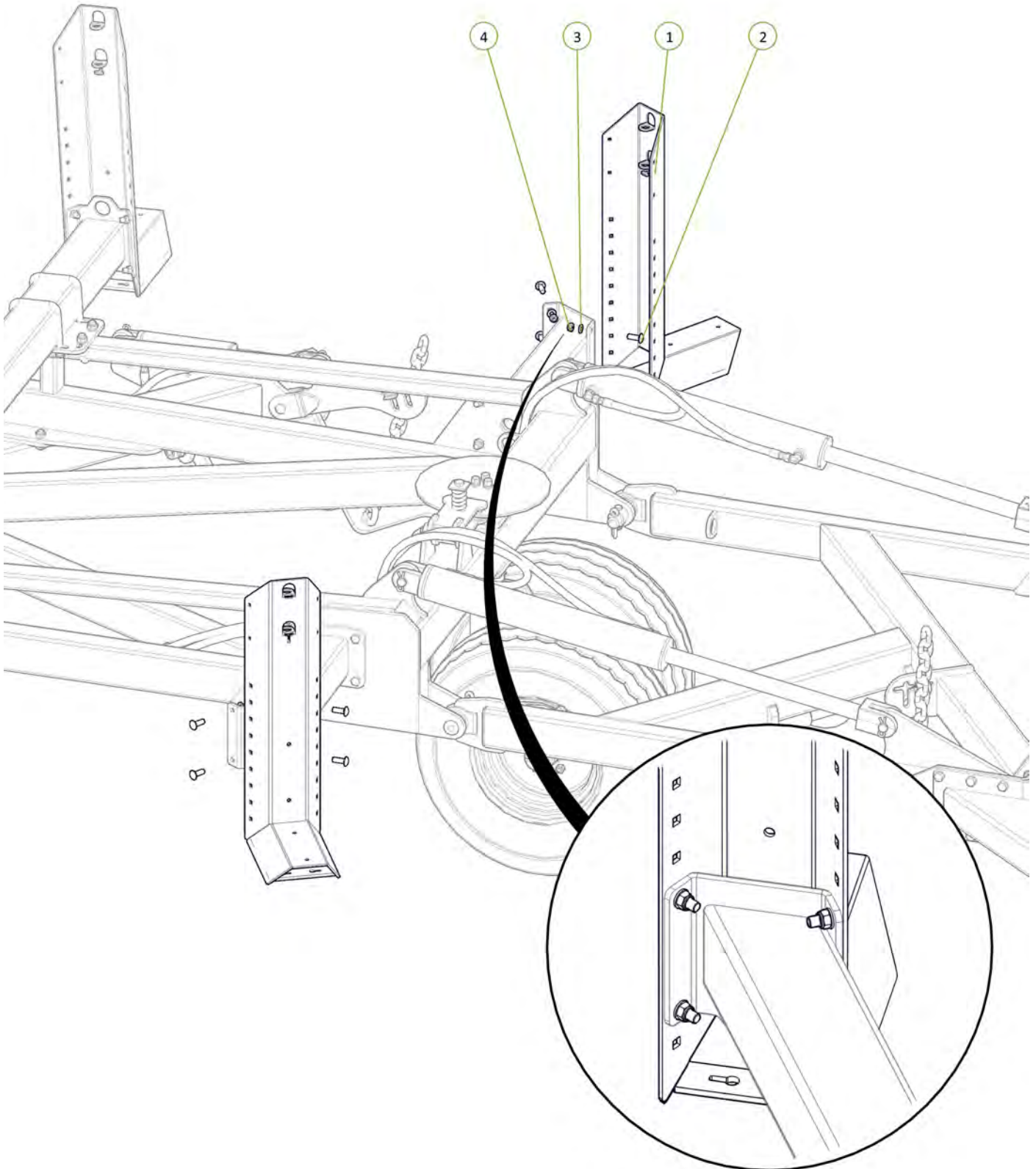
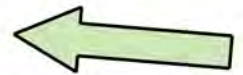

| Item No. | Description                      | Number         | Qty |
|----------|----------------------------------|----------------|-----|
| 1        | Right Hand Off Set M             | 0810-18R       | 1   |
| 2        | Left Hand Off Set M              | 0810-19L       | 1   |
| 3        | U-Bolt M12 x 107 Deep x 106 Wide | 0271-12105104  | 4   |
| 4        | Round Tube Insert 60.3 x 3.2-5mm | 0264-RTRi-5584 | 4   |
| 5        | Washer Flat M12                  | 0231-F12       | 8   |
| 6        | Nyloc Nut M12                    | 0221-NYL12     | 8   |

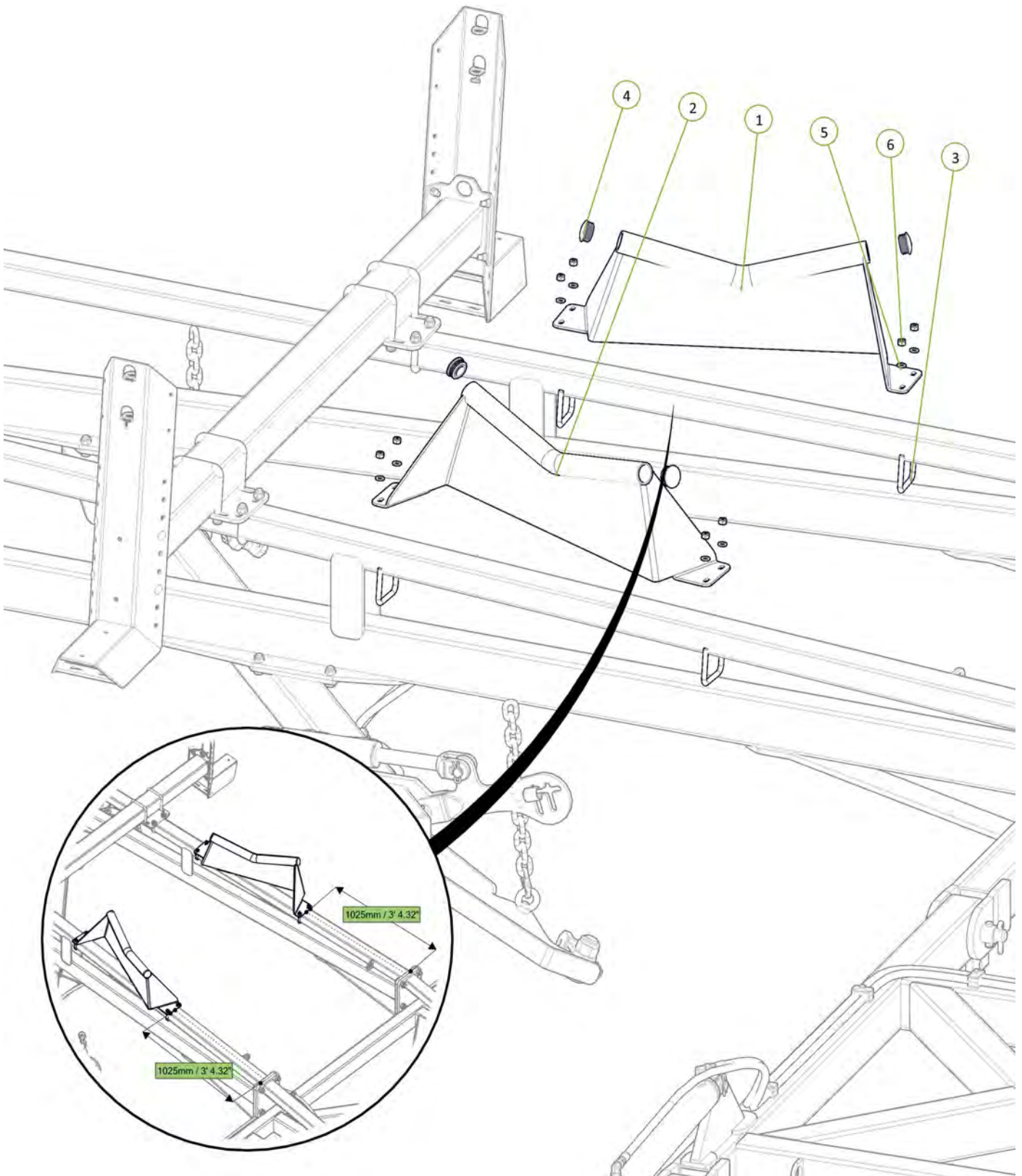
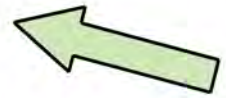



| Item No. | Description                      | Number         | Qty |
|----------|----------------------------------|----------------|-----|
| 1        | Right Hand Off Set M             | 0810-18R       | 1   |
| 2        | Left Hand Off Set M              | 0810-19L       | 1   |
| 3        | Straight Chain Carrier M         | 0810-19        | 1   |
| 4        | Round Tube Insert 60.3 x 3.2-5mm | 0264-RTRI-5584 | 6   |
| 5        | U-Bolt M12 x 80 Deep x 77 Wide   | 0271-128077    | 4   |
| 6        | U-Bolt M12 x 157 Deep x 79 Wide  | 0271-1215577   | 2   |
| 7        | Washer Flat M12                  | 0231-F12       | 12  |
| 8        | Nyloc Nut M12                    | 0221-NYL12     | 12  |

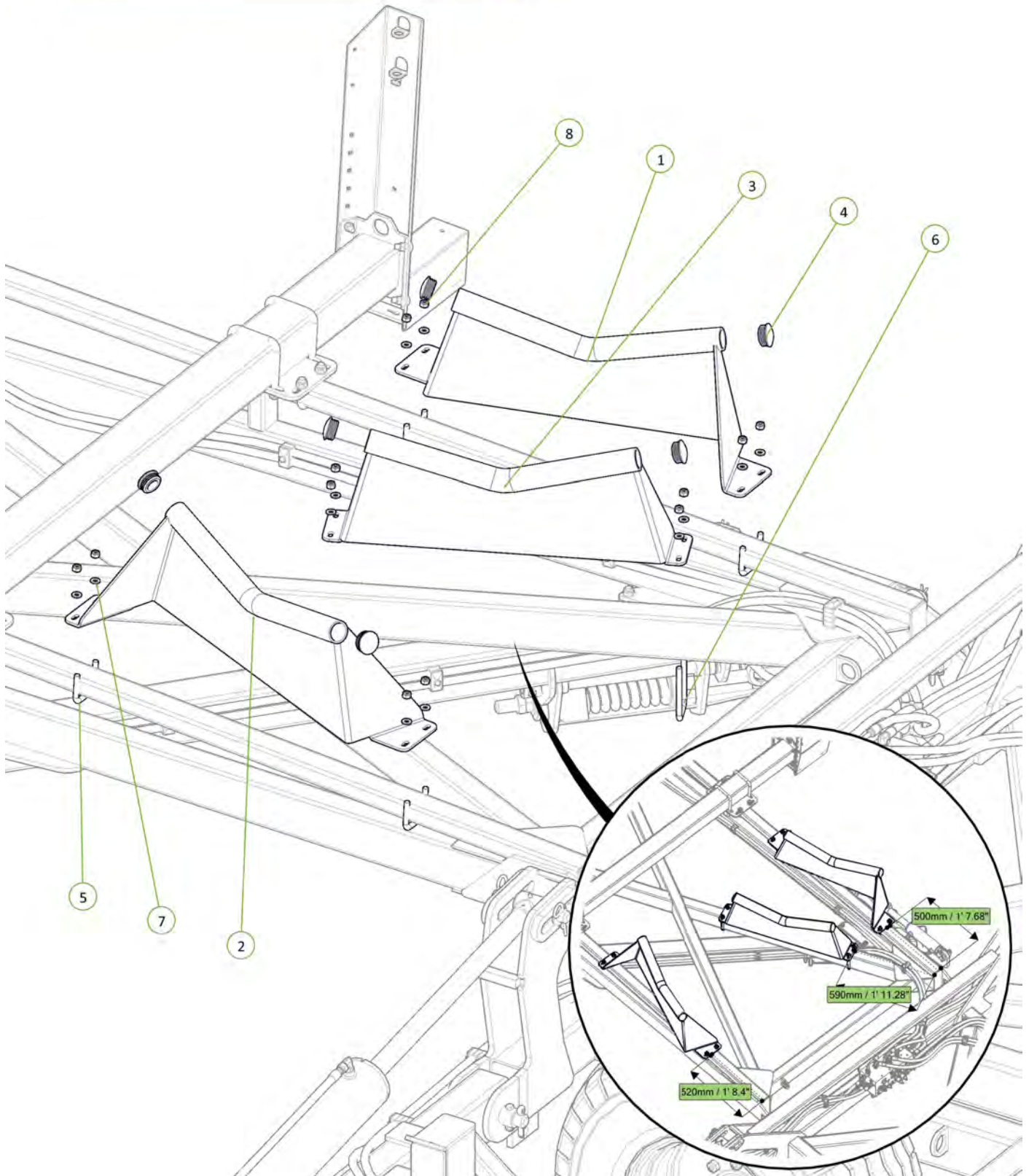
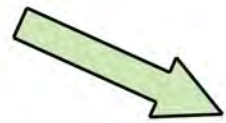



| Item No. | Description                      | Number          | Qty |
|----------|----------------------------------|-----------------|-----|
| 1        | LH Oversize Sign Frame           | 0810-110        | 1   |
| 2        | RH Oversize Sign Frame           | 0810-111        | 1   |
| 3        | Oversize Sign Left Hand          | 0801-SIGNOSL    | 1   |
| 4        | Oversize Sign Right Hand         | 0801-SIGNOSR    | 1   |
| 5        | U-Bolt M12 x 155 Deep x 127 Wide | 0271-12155127   | 4   |
| 6        | TEK Screw 10g 16 x 16            | 0241-TEK10-1616 | 20  |
| 7        | Washer Flat M12                  | 0231-F12        | 8   |
| 8        | Nyloc Nut M12                    | 0221-NYL12      | 8   |

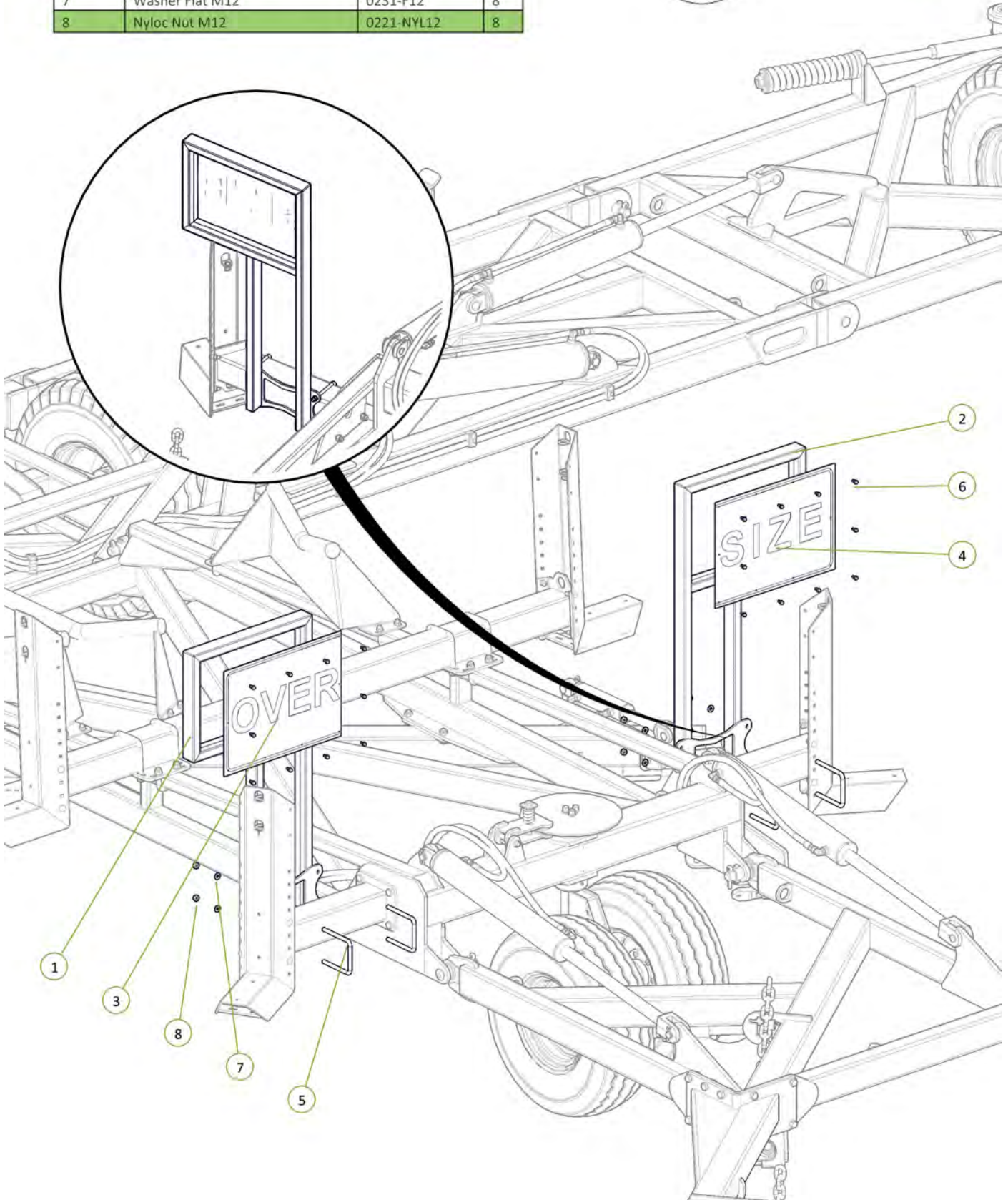
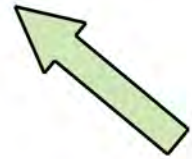

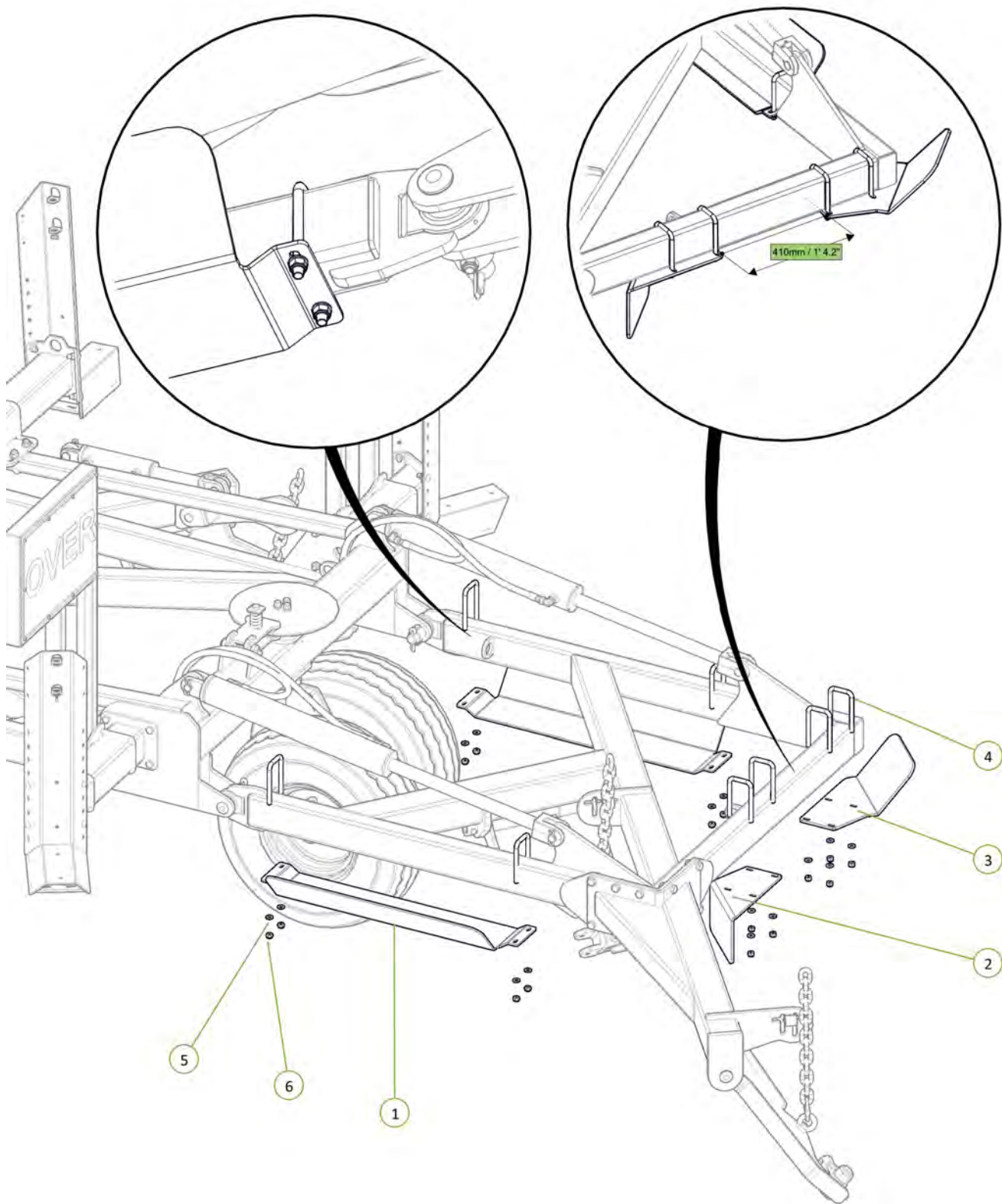

| Item No. | Description                     | Number       | Qty |
|----------|---------------------------------|--------------|-----|
| 1        | Rear Tail Guard                 | 0800-235     | 2   |
| 2        | Tail Chain Stop Guard           | 0800-220.1   | 1   |
| 3        | Angled Chain Gaurd              | 0800-498     | 1   |
| 4        | U-Bolt M12 x 157 Deep x 79 Wide | 0271-1215577 | 8   |
| 5        | Washer Flat M12                 | 0231-F12     | 16  |
| 6        | Nyloc Nut M12                   | 0221-NYL12   | 16  |





| Item No. | Description                     | Number       | Qty |
|----------|---------------------------------|--------------|-----|
| 1        | Rear A-Frame Chain Shield       | 0800-230     | 1   |
| 2        | U-Bolt M12 x 157 Deep x 79 Wide | 0271-1215577 | 2   |
| 3        | Washer Flat M12                 | 0231-F12     | 4   |
| 4        | Nyloc Nut M12                   | 0221-NYL12   | 4   |

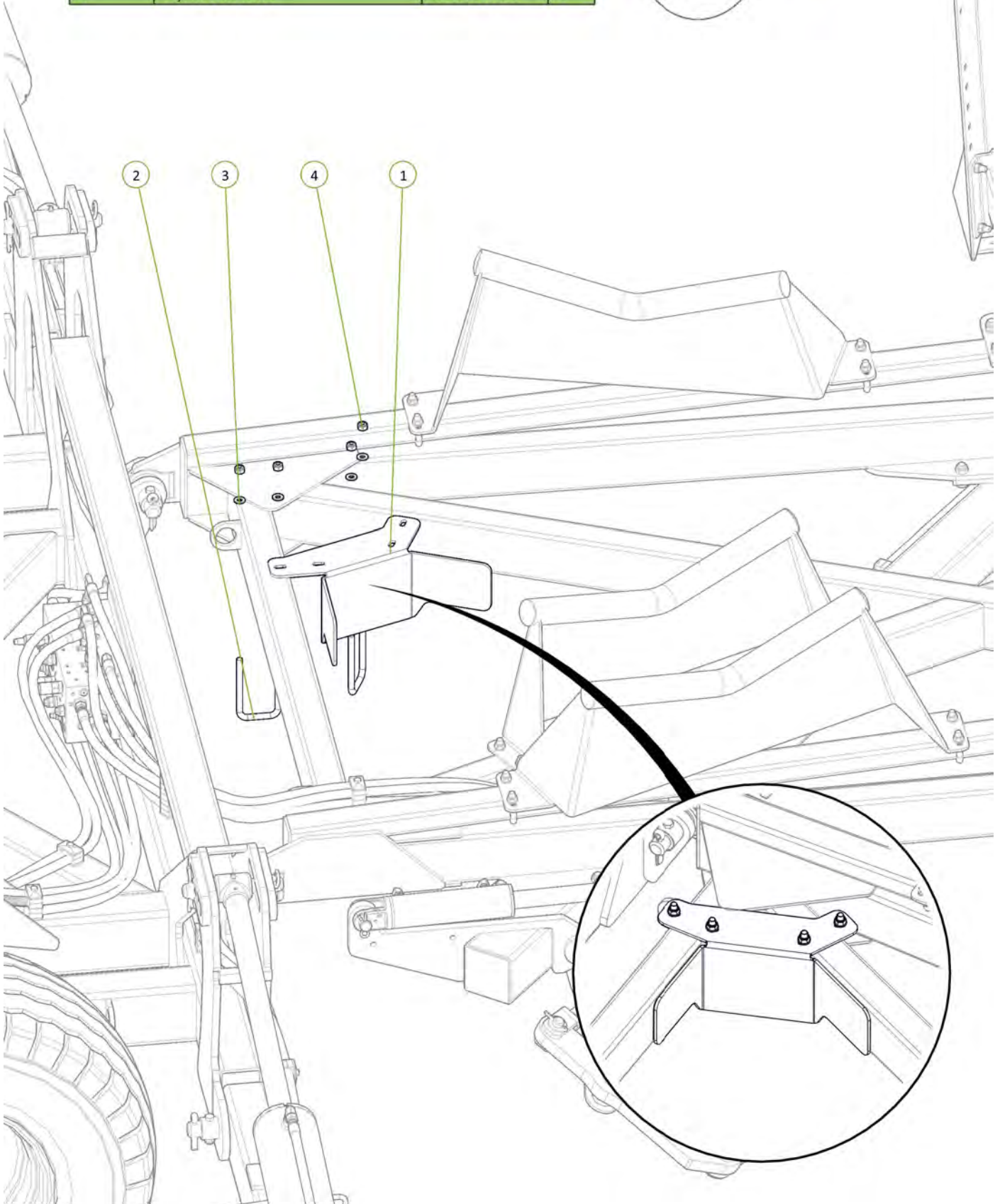



| Item No. | Description                | Number     | Qty |
|----------|----------------------------|------------|-----|
| 1        | Module Cylinder Guard      | 0800-167.3 | 1   |
| 2        | M12 x 50 grade 8.8 ZP Bolt | 0211-1250  | 2   |
| 3        | Nyloc Nut M12              | 0221-NYL12 | 2   |

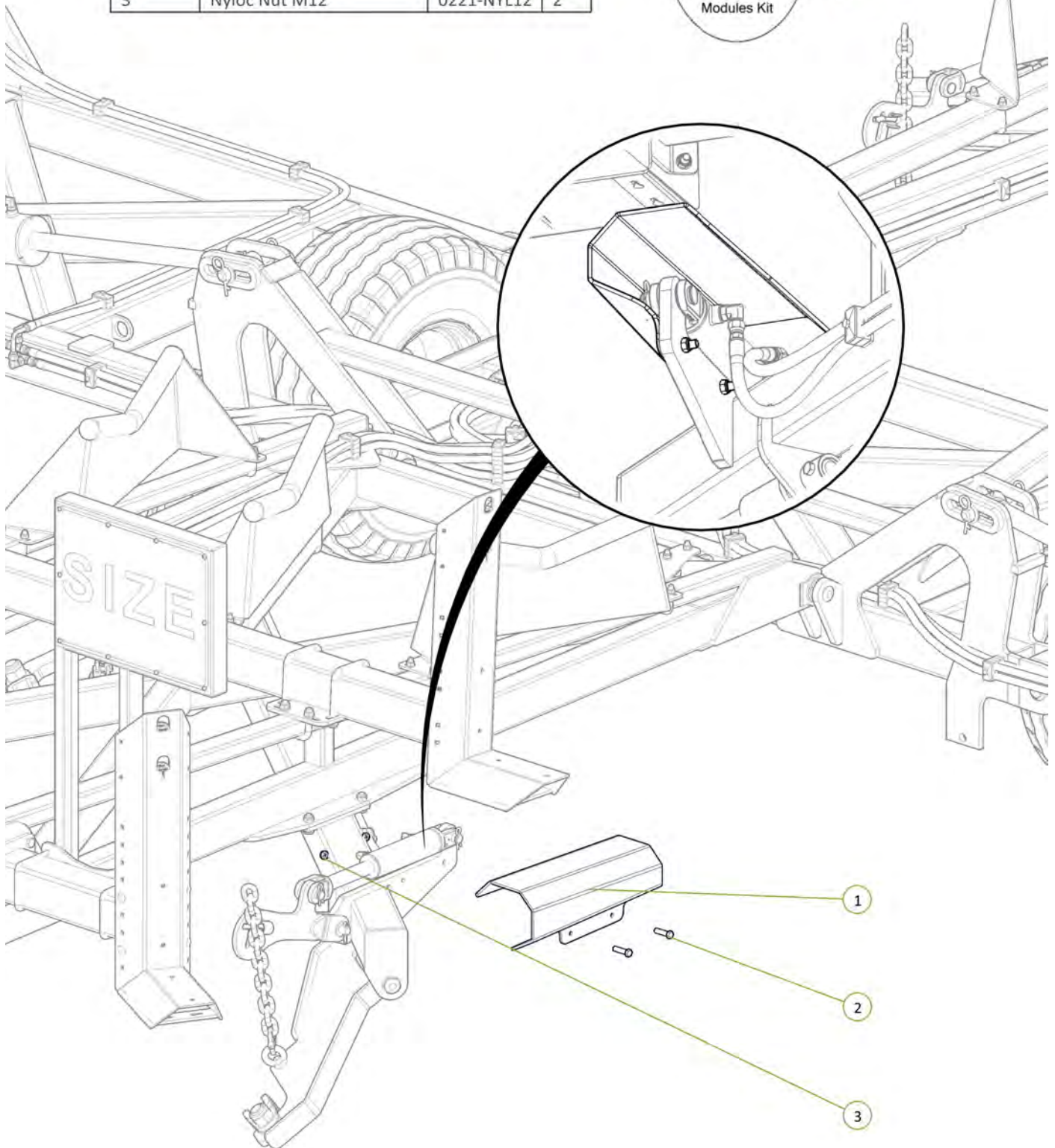
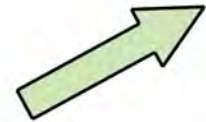

| Item No. | Description           | Number  | Qty |
|----------|-----------------------|---------|-----|
| 1        | Safety Chain Assembly | 0810-16 | 1   |

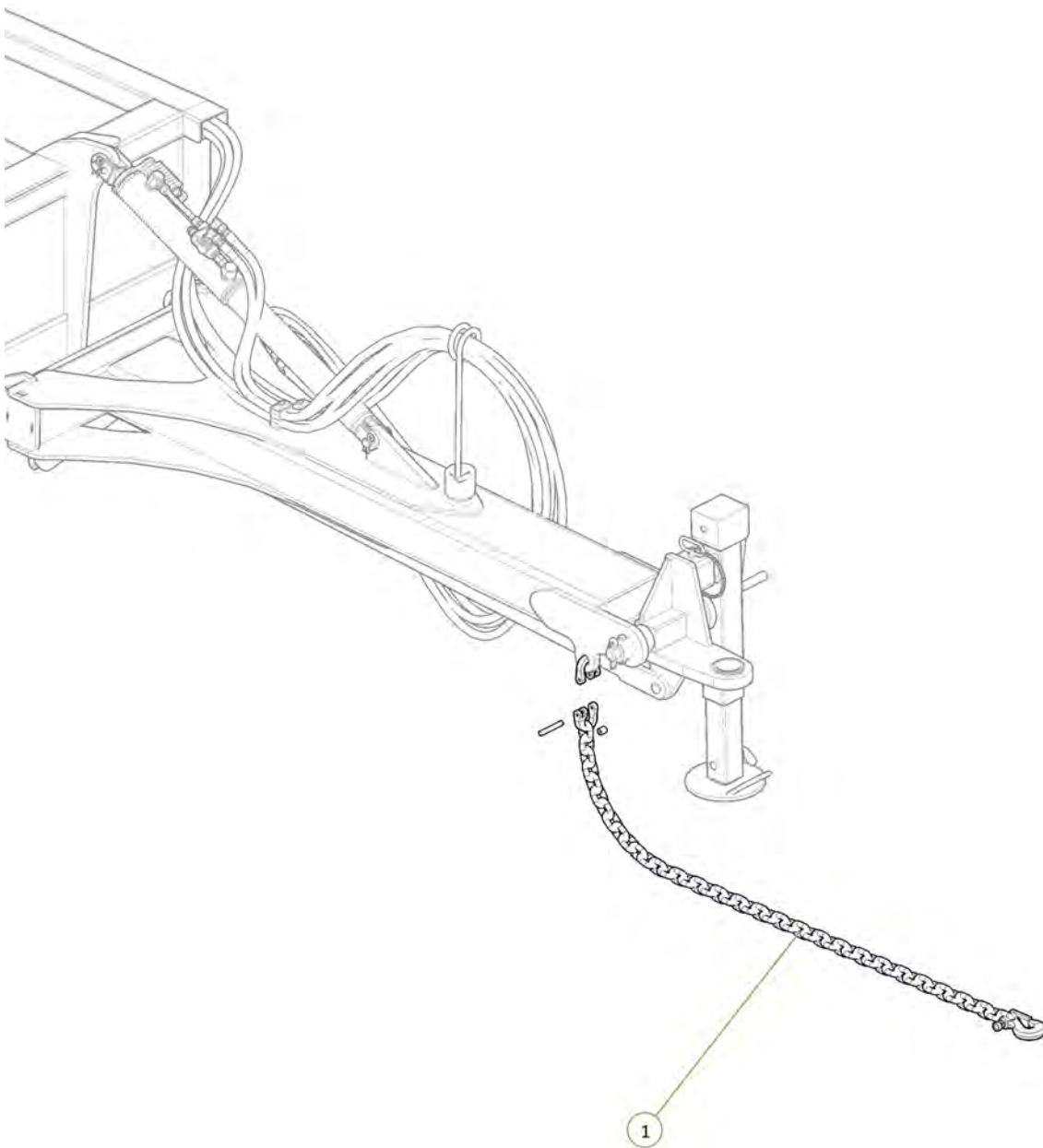

| Item No. | Description                               | Number          | Qty |
|----------|---|-----------------|-----|
| 1        | Operator Manual Cannister                 | 0801-OMC-1      | 1   |
| 2        | Ratcheting Gear Wrench 1 3/4"             | 0802-GW1 3-4    | 1   |
| 3        | 20mm Bolt Swivel Unit                     | 0802-PCHB55     | 1   |
| 4        | M20 x 110 grade 10.9 ZP Short Thread Bolt | 0211-20110ST    | 1   |
| 5        | Nyloc Nut M20                             | 0221-NYL20      | 1   |
| 6        | M6 x 20 Trilobe self tapping ScREW        | 0211-M620MZPHTF | 3   |

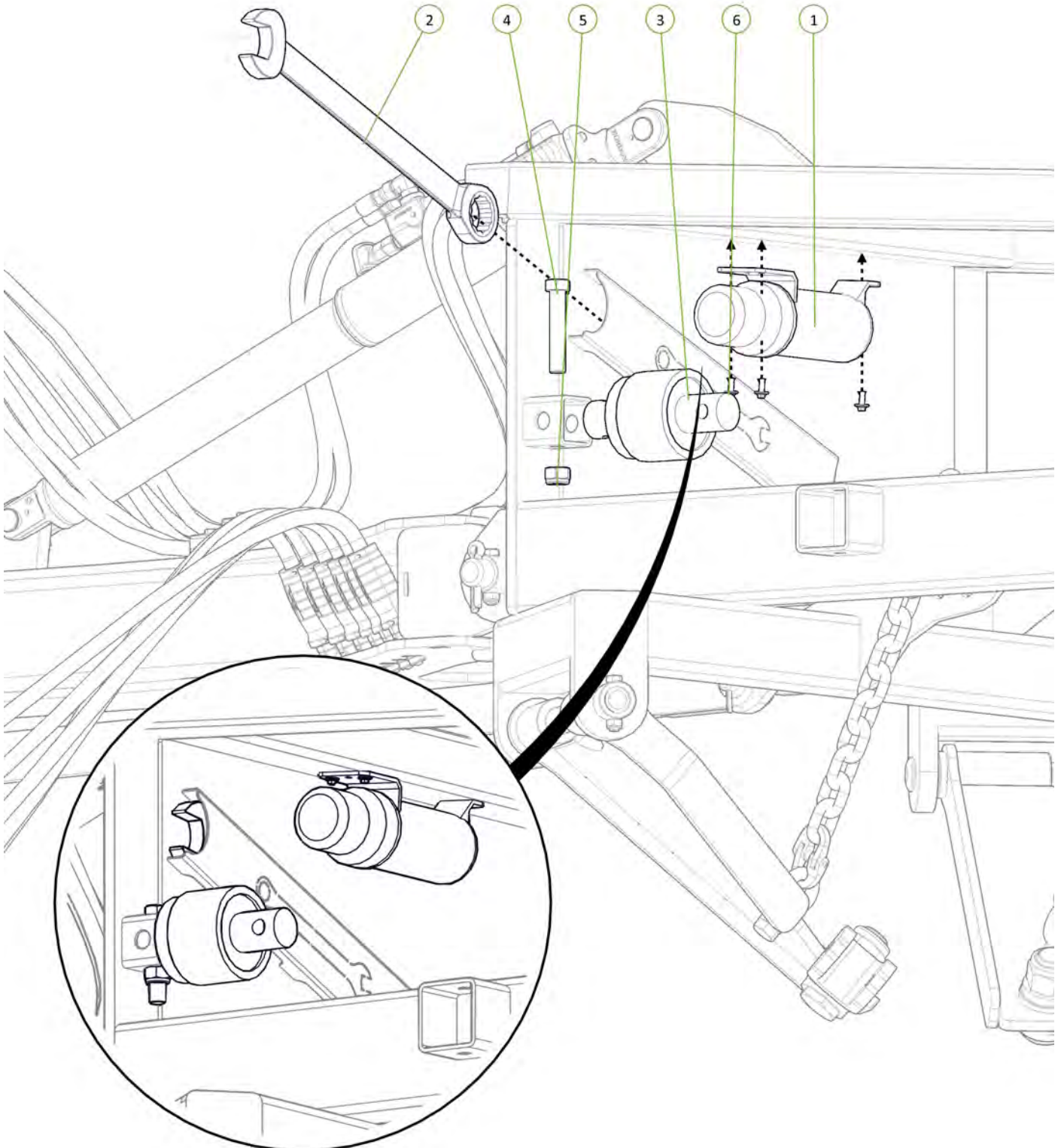



| Item No. | Description             | Number            | Qty |
|----------|-------------------------|-------------------|-----|
| 1        | Cylinder Safety Stop    | 0800-212.1        | 1   |
| 2        | Square Loop Pin M8 x 63 | 0511-PINLOOPSQ863 | 1   |

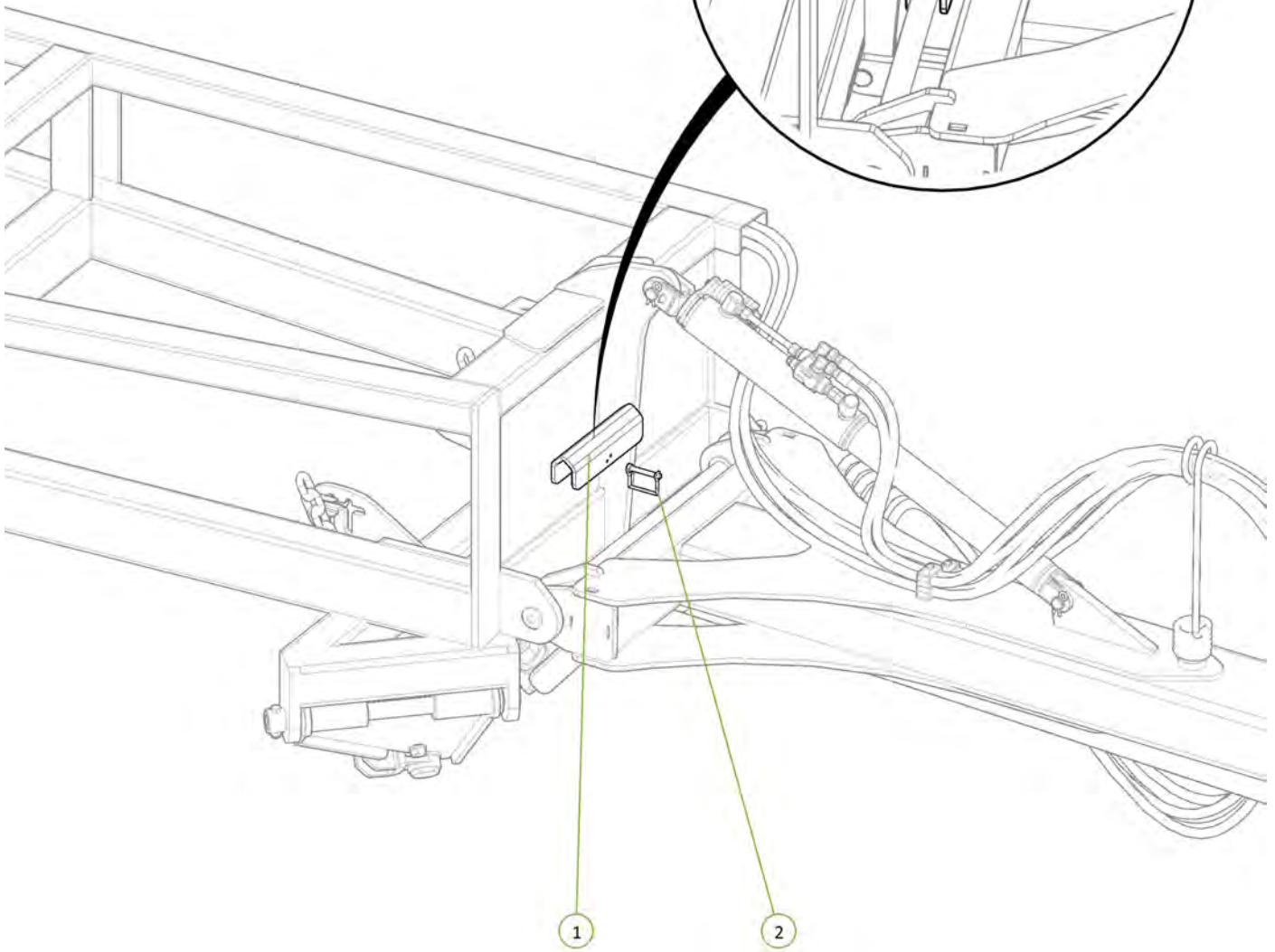
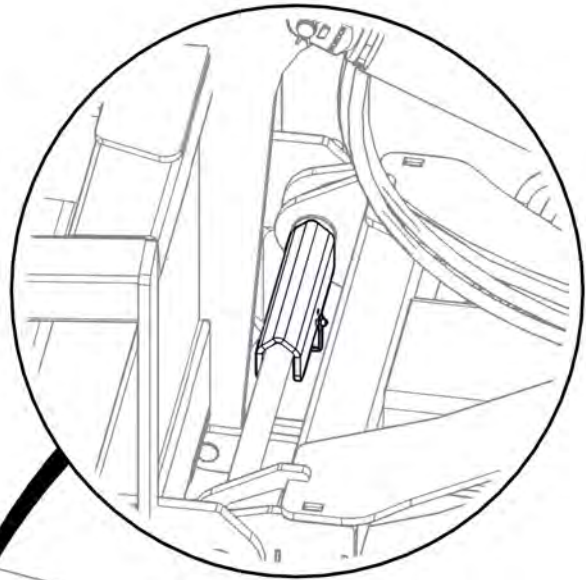

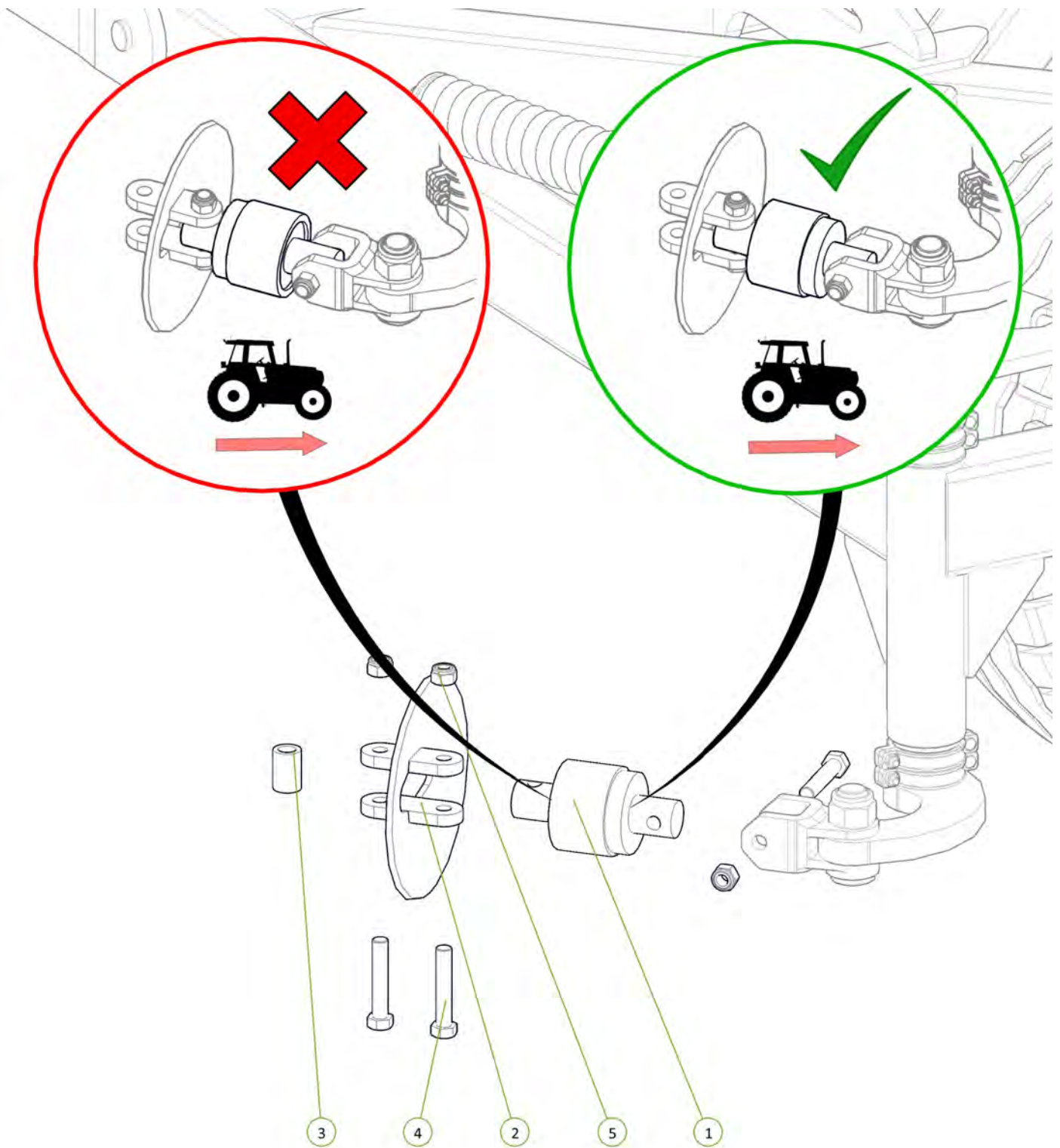

| Item No. | Description                               | Number       | Qty |
|----------|---|--------------|-----|
| 1        | 20mm Bolt Swivel Unit                     | 0802-PCHB55  | 1   |
| 2        | Disc Chain Tie Plate Link 20mm            | 0802-DCTP-20 | 1   |
| 3        | Tie Plate Bush                            | 0801-PCDCS55 | 1   |
| 4        | M20 x 110 grade 10.9 ZP Short Thread Bolt | 0211-20110ST | 3   |
| 5        | Nyloc Nut M20                             | 0221-NYL20   | 3   |

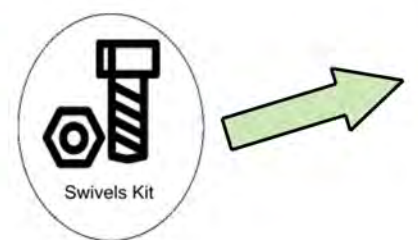

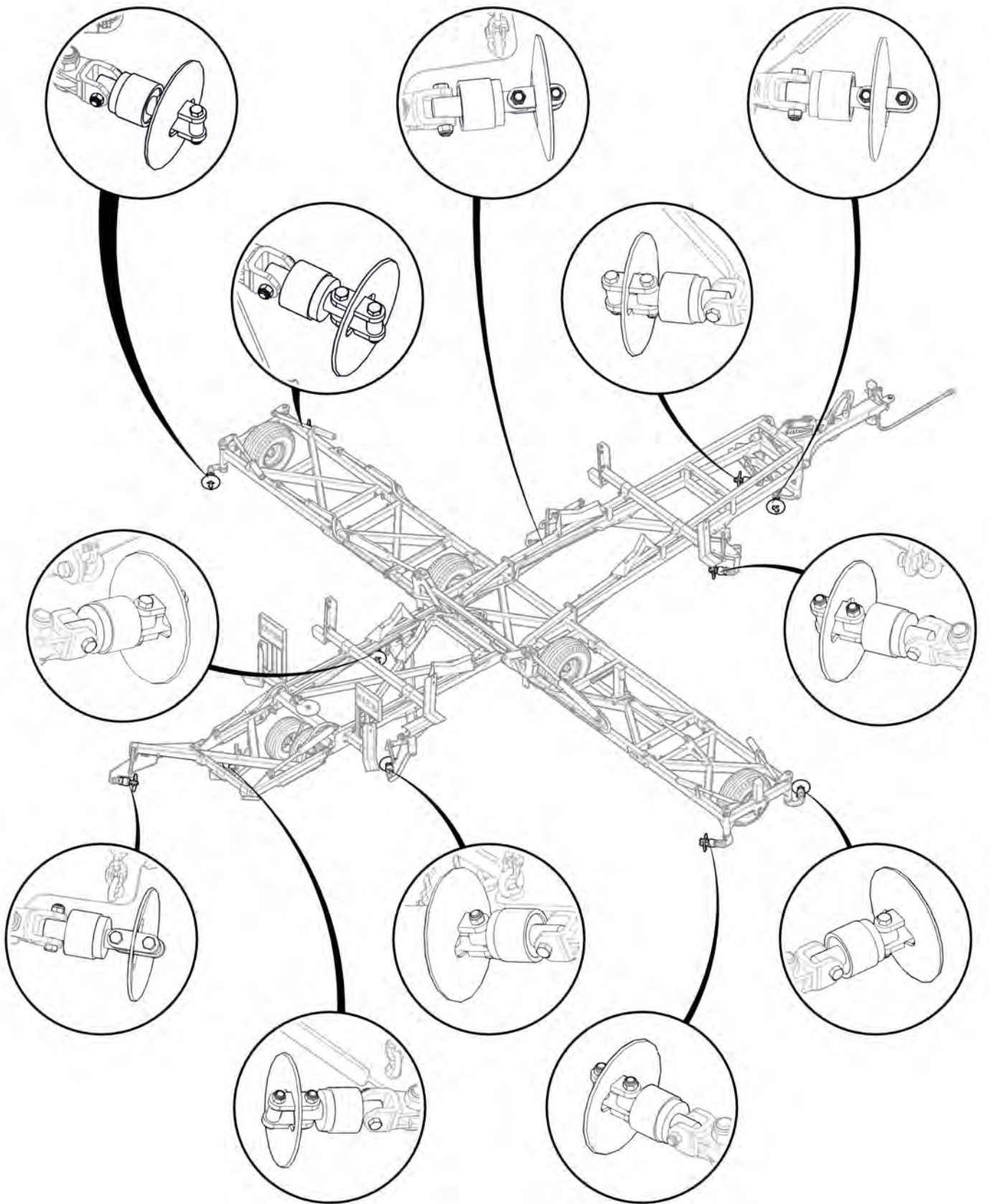

All bearings correctly orientated with seal facing the rear of the machine 

Signed \_\_\_\_\_ Date \_\_\_\_ / \_\_\_\_ / \_\_\_\_  
Unit Serial Number: \_\_\_\_\_



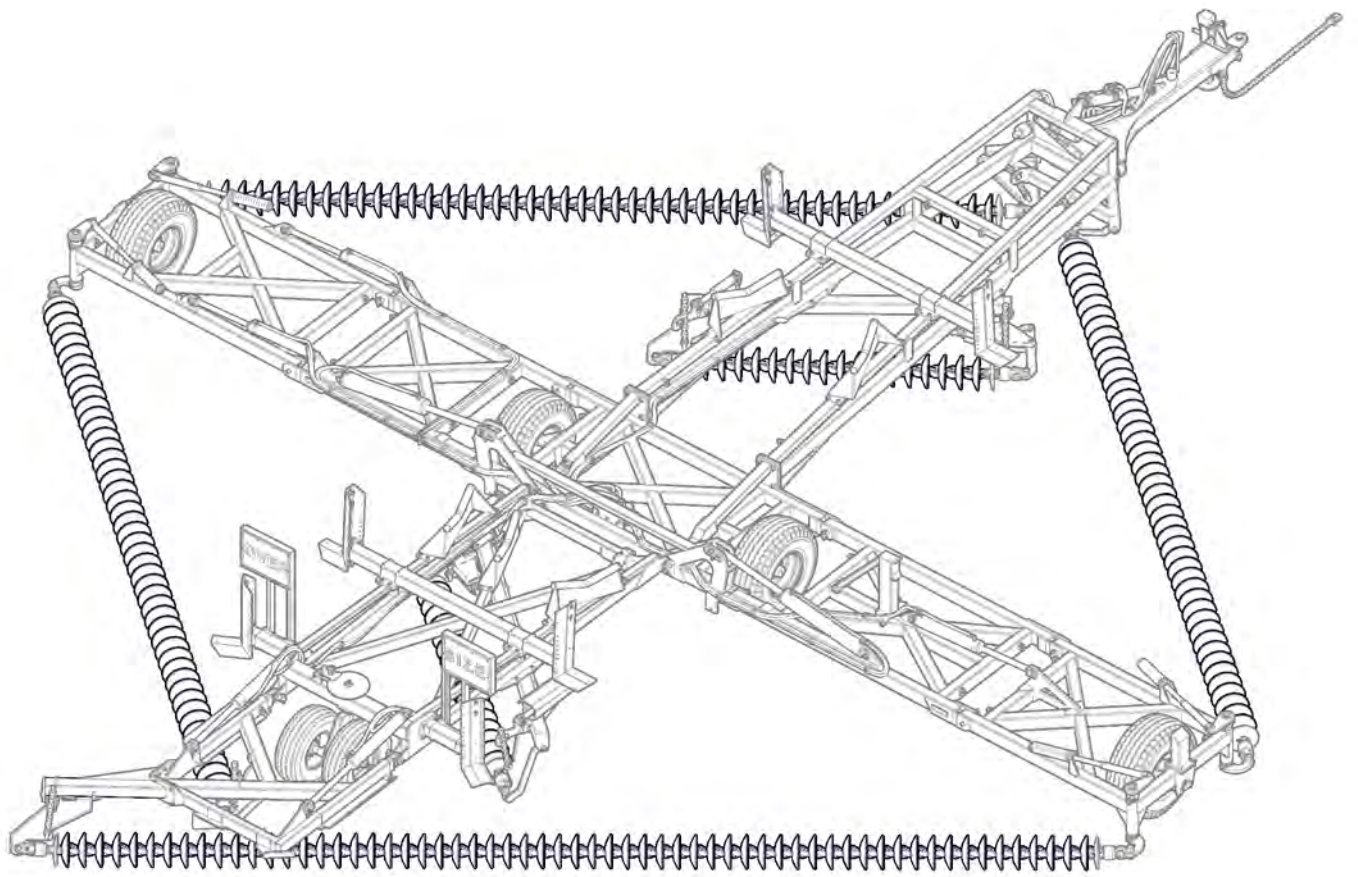

# Section 3

## Decal Placement

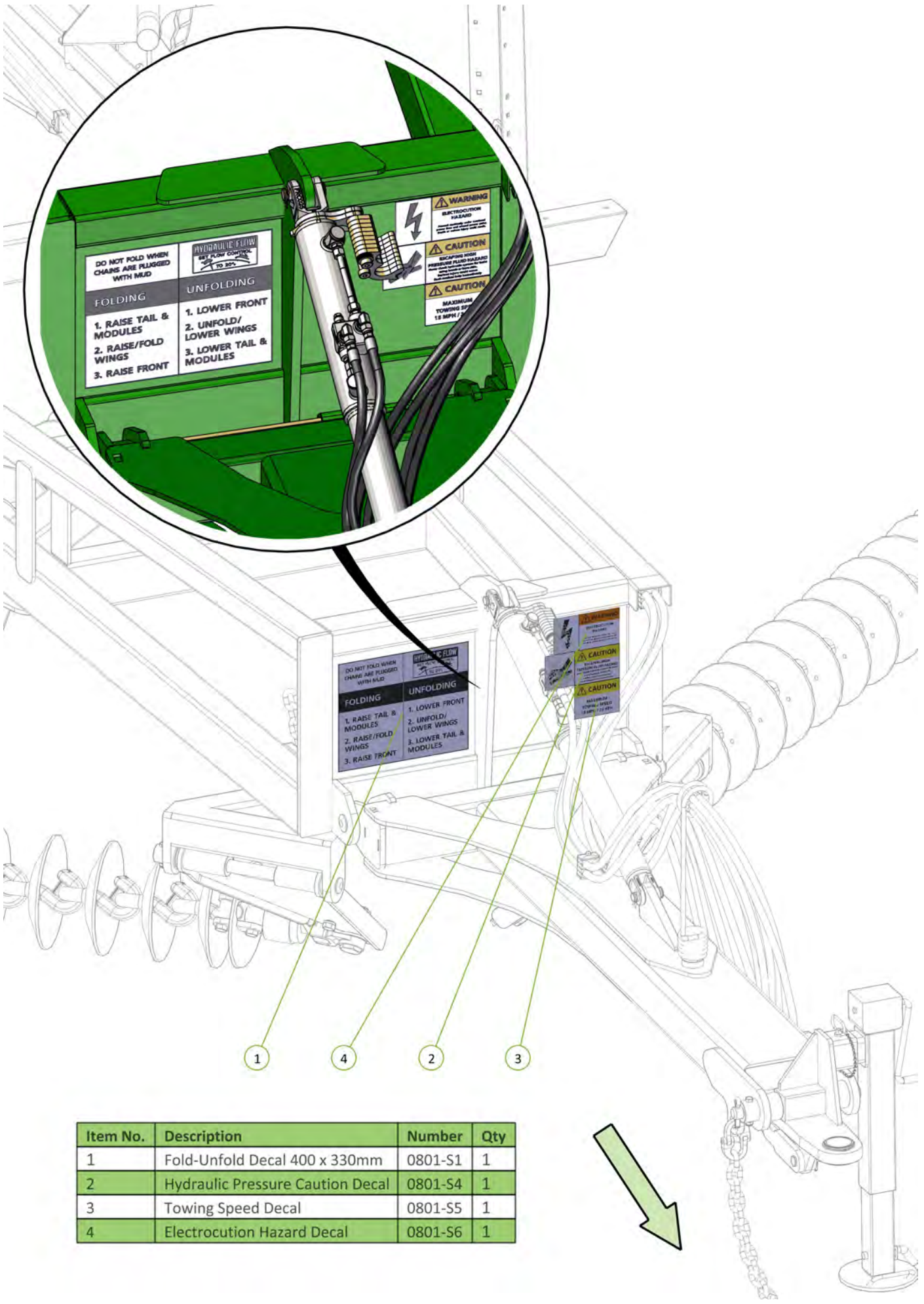

| Item No. | Description                      | Number  | Qty |
|----------|----------------------------------|---------|-----|
| 1        | Fold-Unfold Decal 400 x 330mm    | 0801-S1 | 1   |
| 2        | Hydraulic Pressure Caution Decal | 0801-S4 | 1   |
| 3        | Towing Speed Decal               | 0801-S5 | 1   |
| 4        | Electrocution Hazard Decal       | 0801-S6 | 1   |



| Item No. | Description | Number   | Qty |
|----------|-------------|----------|-----|
| 1        | Data Plate  | 0801-SDP | 1   |

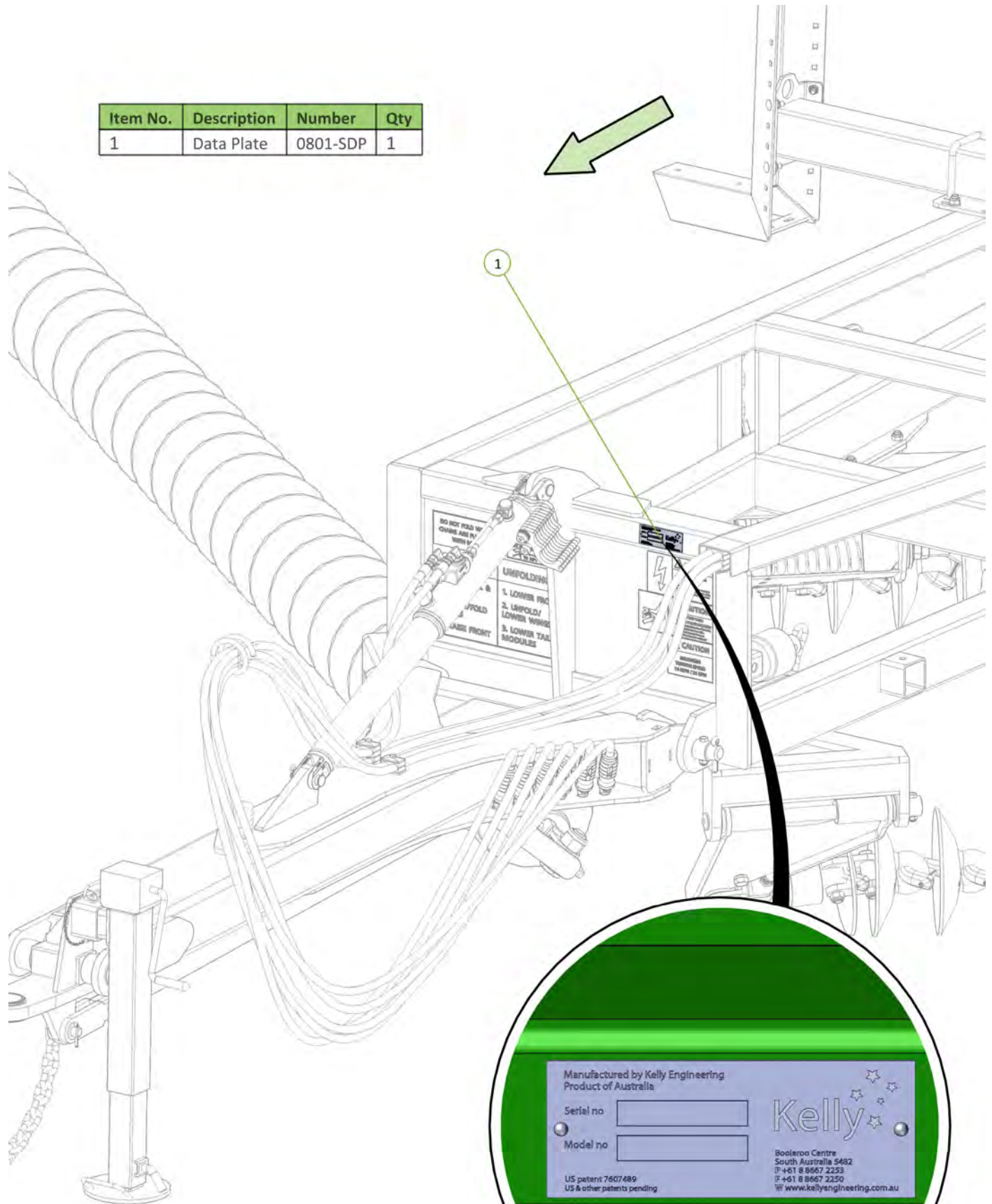

| Item No. | Description             | Number   | Qty |
|----------|-------------------------|----------|-----|
| 1        | Kelly Engineering Decal | 0801-S12 | 2   |

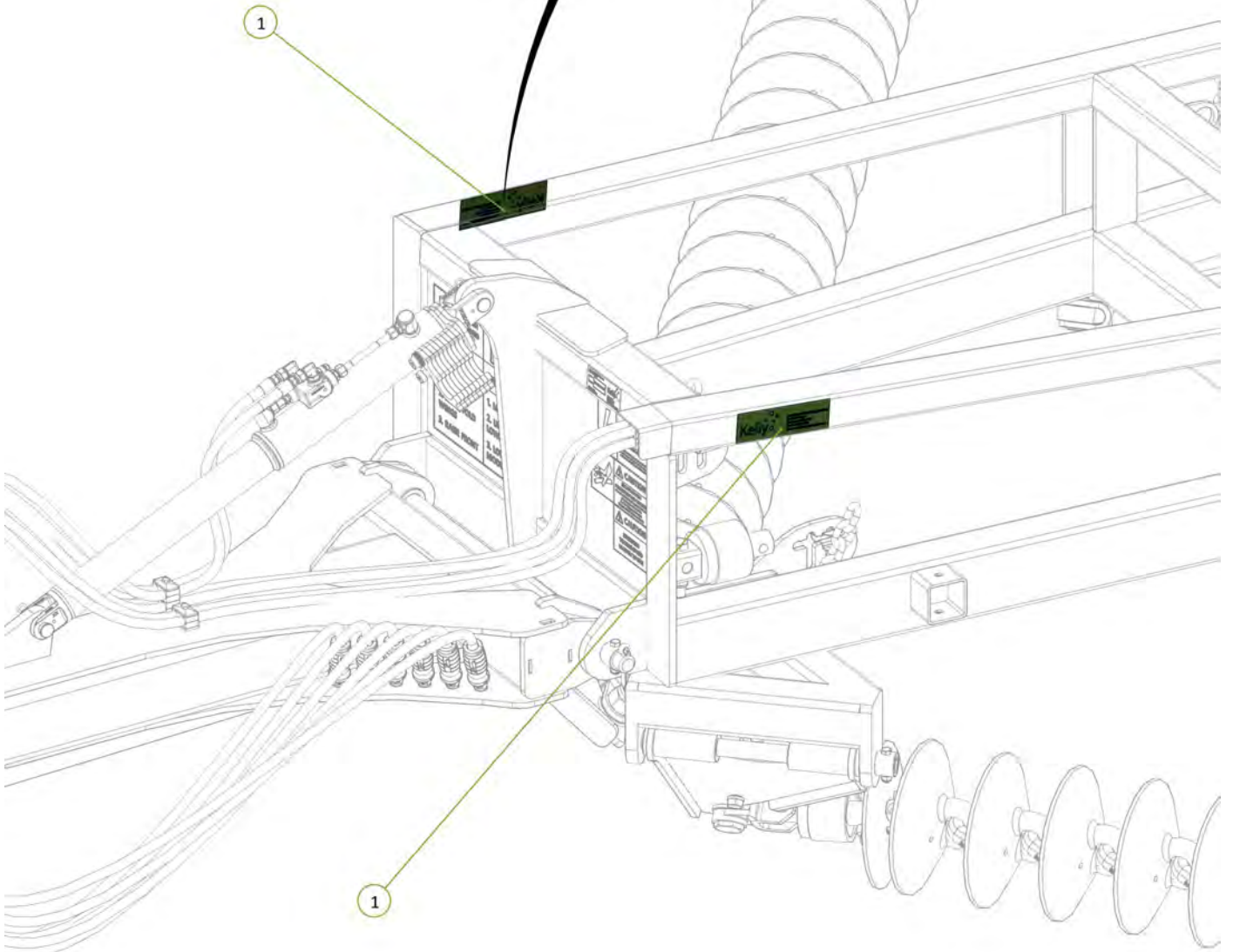
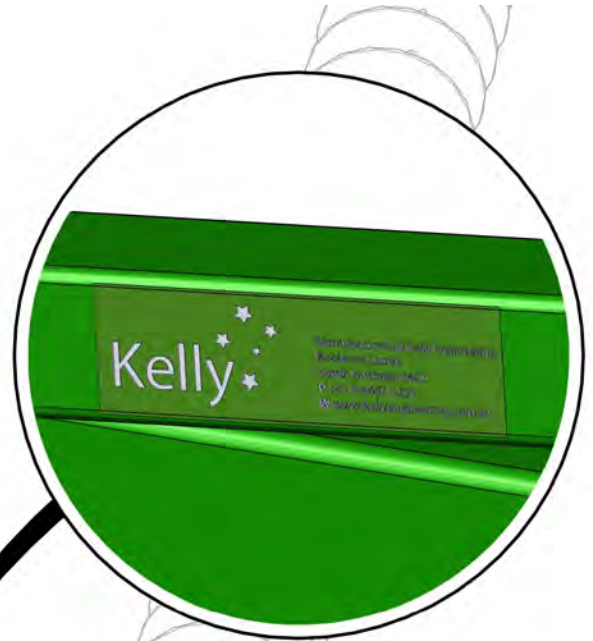

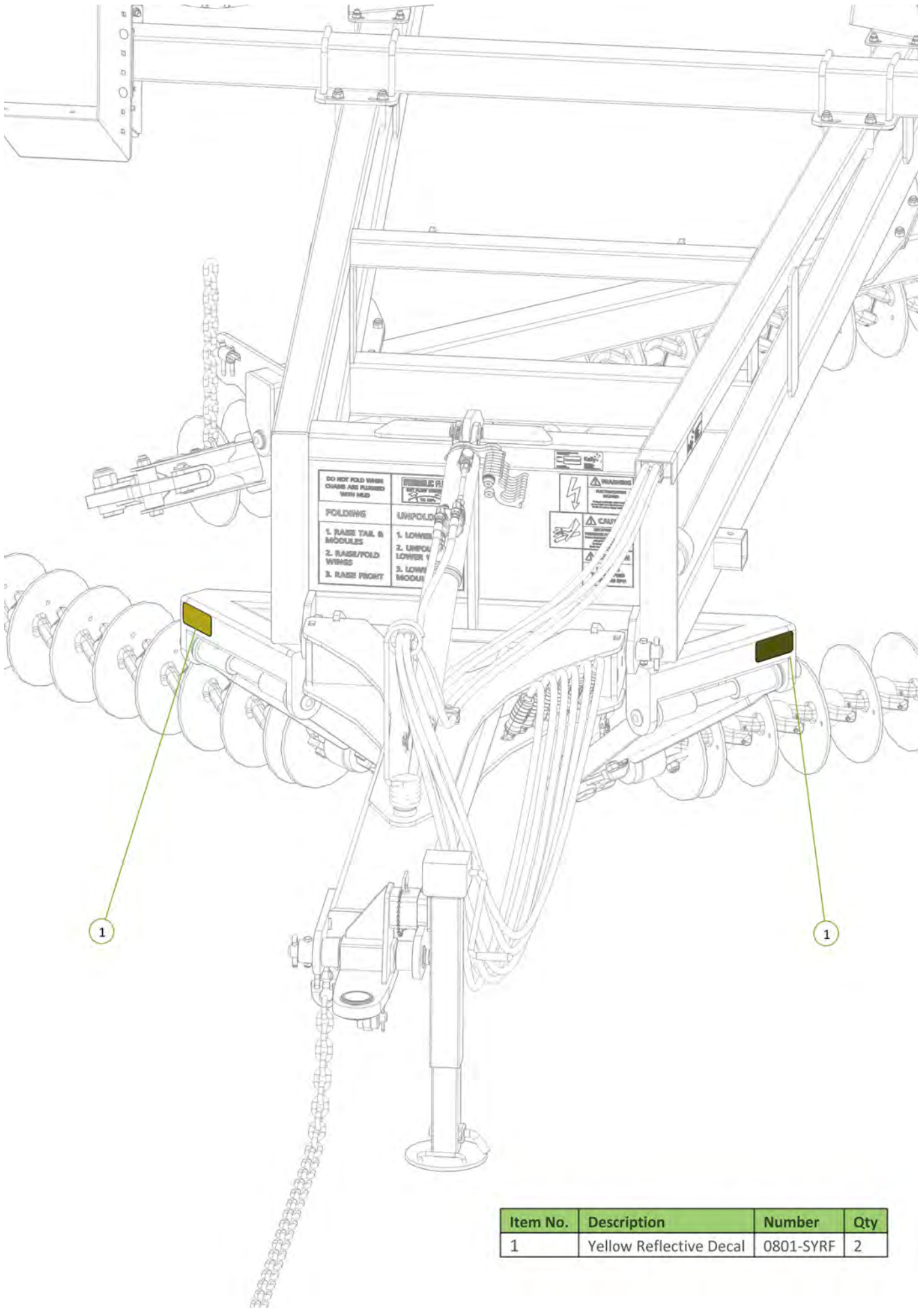

| Item No. | Description             | Number    | Qty |
|----------|-------------------------|-----------|-----|
| 1        | Yellow Reflective Decal | 0801-SYRF | 2   |



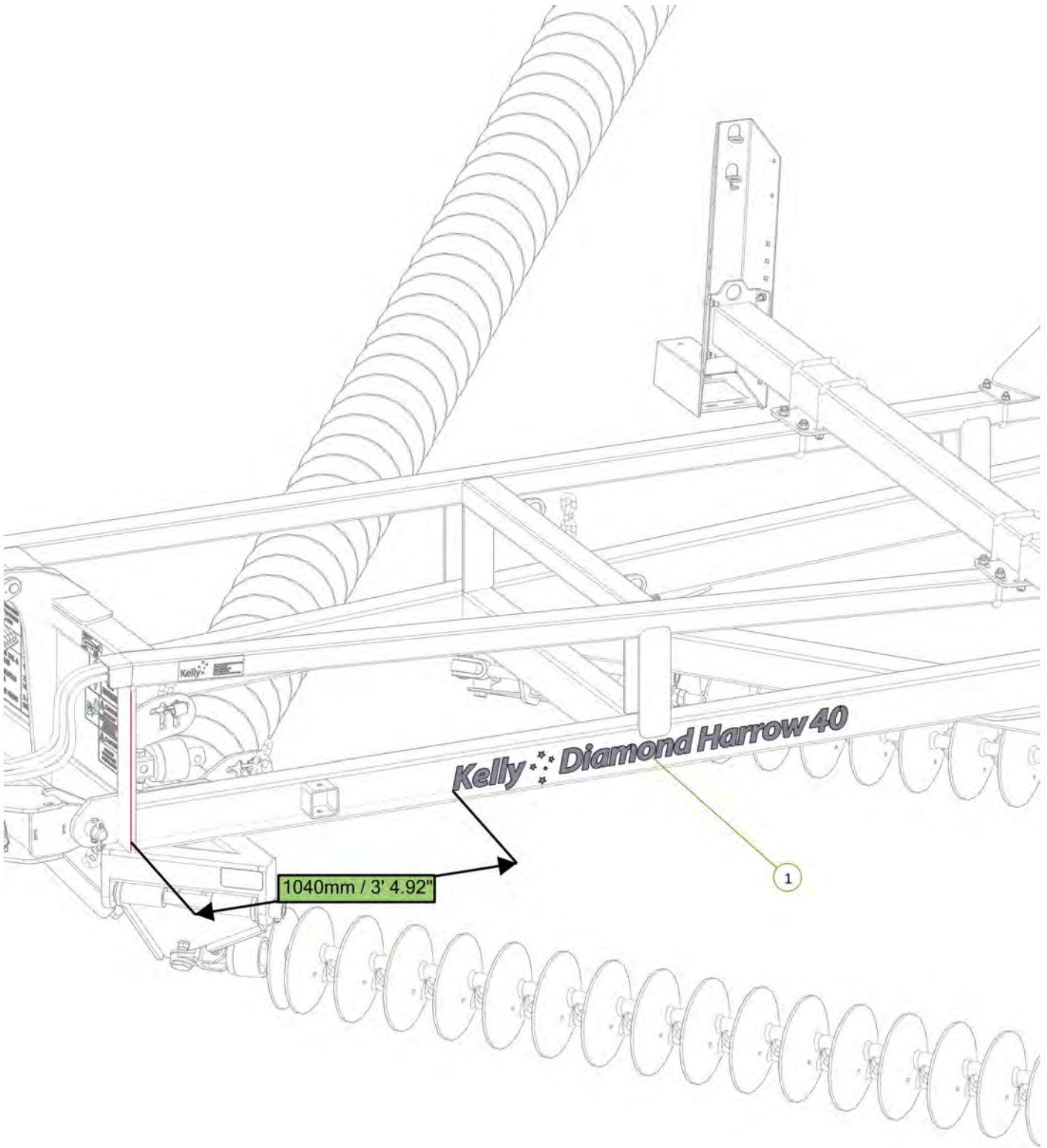

| Item No. | Description             | Number      | Qty |
|----------|-------------------------|-------------|-----|
| 1        | Diamond Harrow 40 Decal | 0801-SKDH40 | 1   |



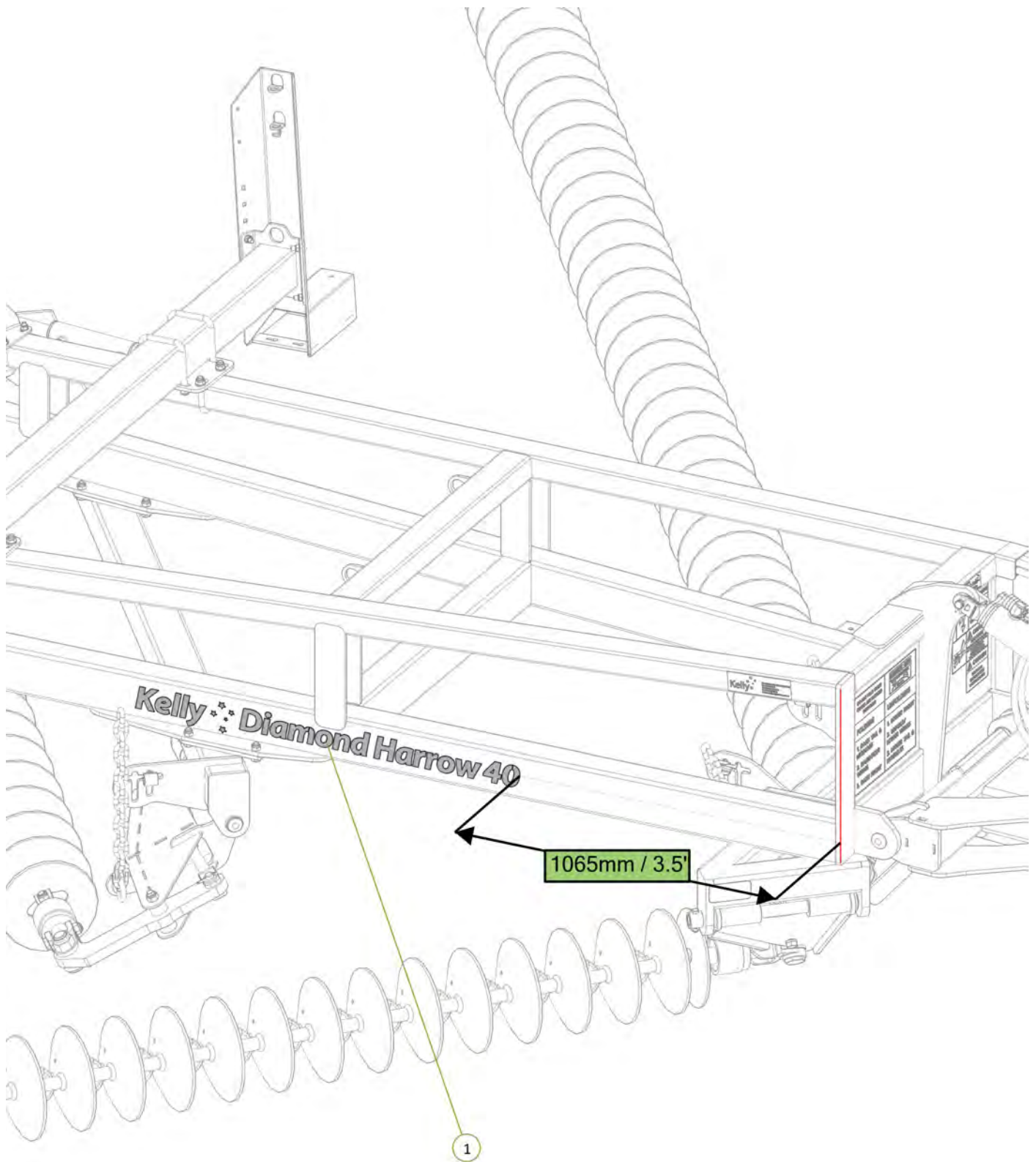

| Item No. | Description             | Number      | Qty |
|----------|-------------------------|-------------|-----|
| 1        | Diamond Harrow 40 Decal | 0801-SKDH40 | 1   |

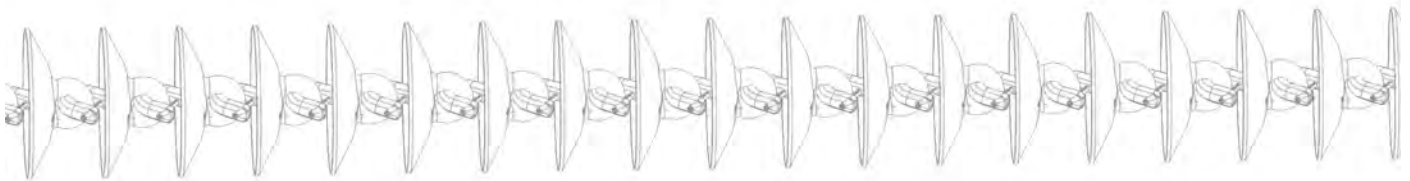
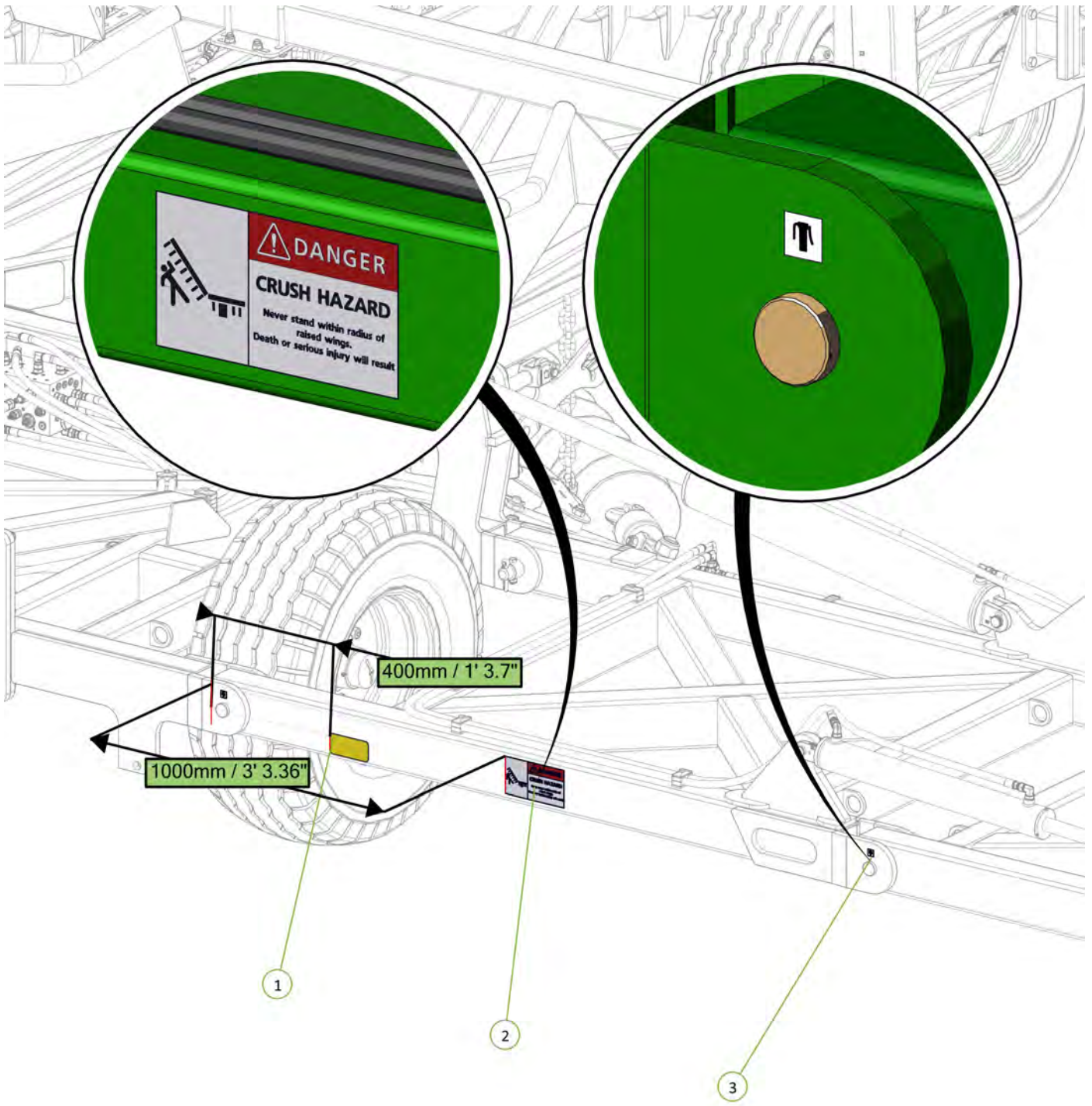

| Item No. | Description               | Number    | Qty |
|----------|---------------------------|-----------|-----|
| 1        | Yellow Reflective Decal   | 0801-SYRF | 1   |
| 2        | Danger Crush Hazard Decal | 0801-S3   | 1   |
| 3        | Grease Decal              | 0801-S10  | 2   |





| Item No. | Description             | Number    | Qty |
|----------|-------------------------|-----------|-----|
| 1        | Yellow Reflective Decal | 0801-SYRF | 1   |

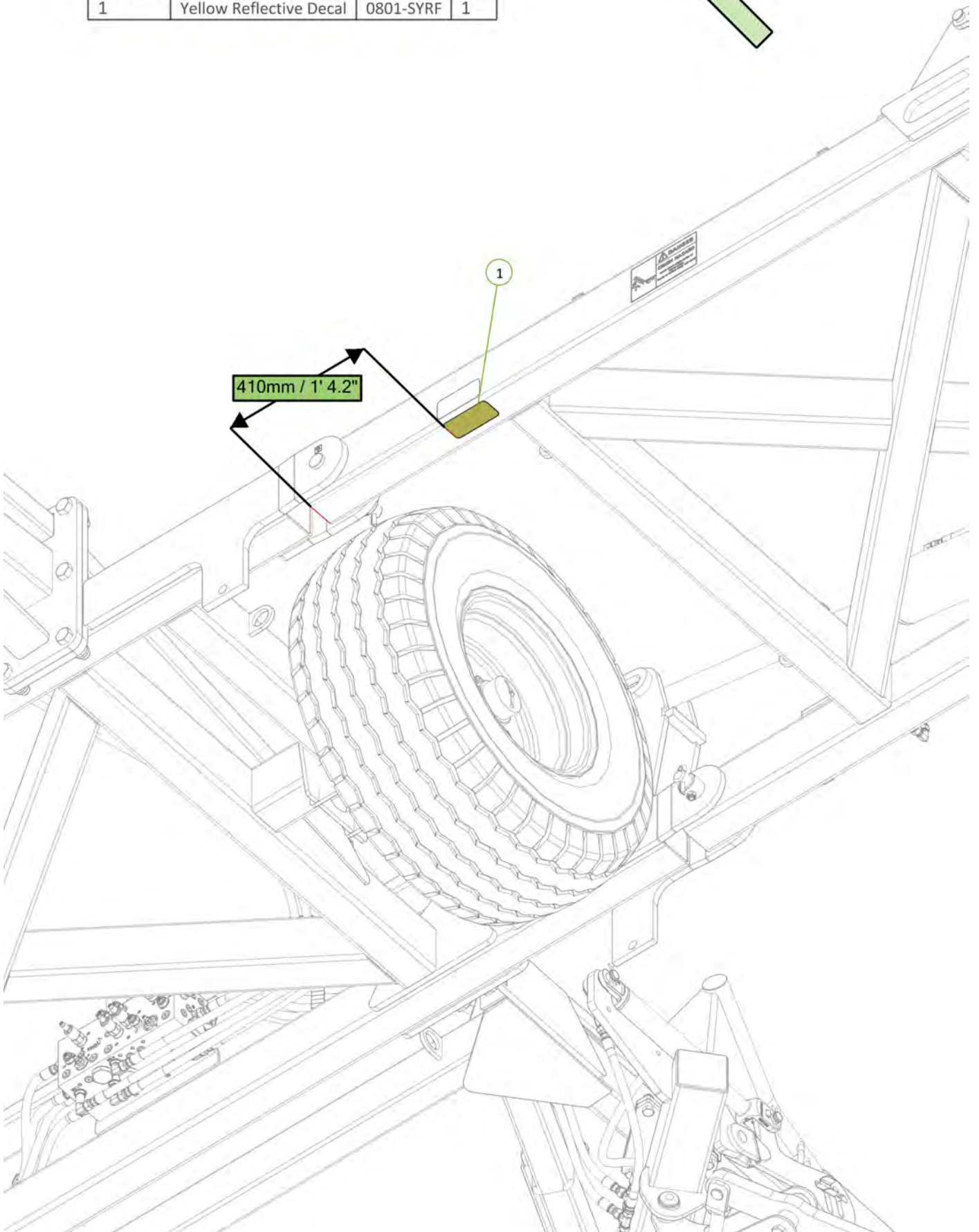
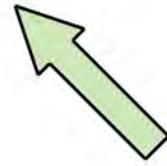

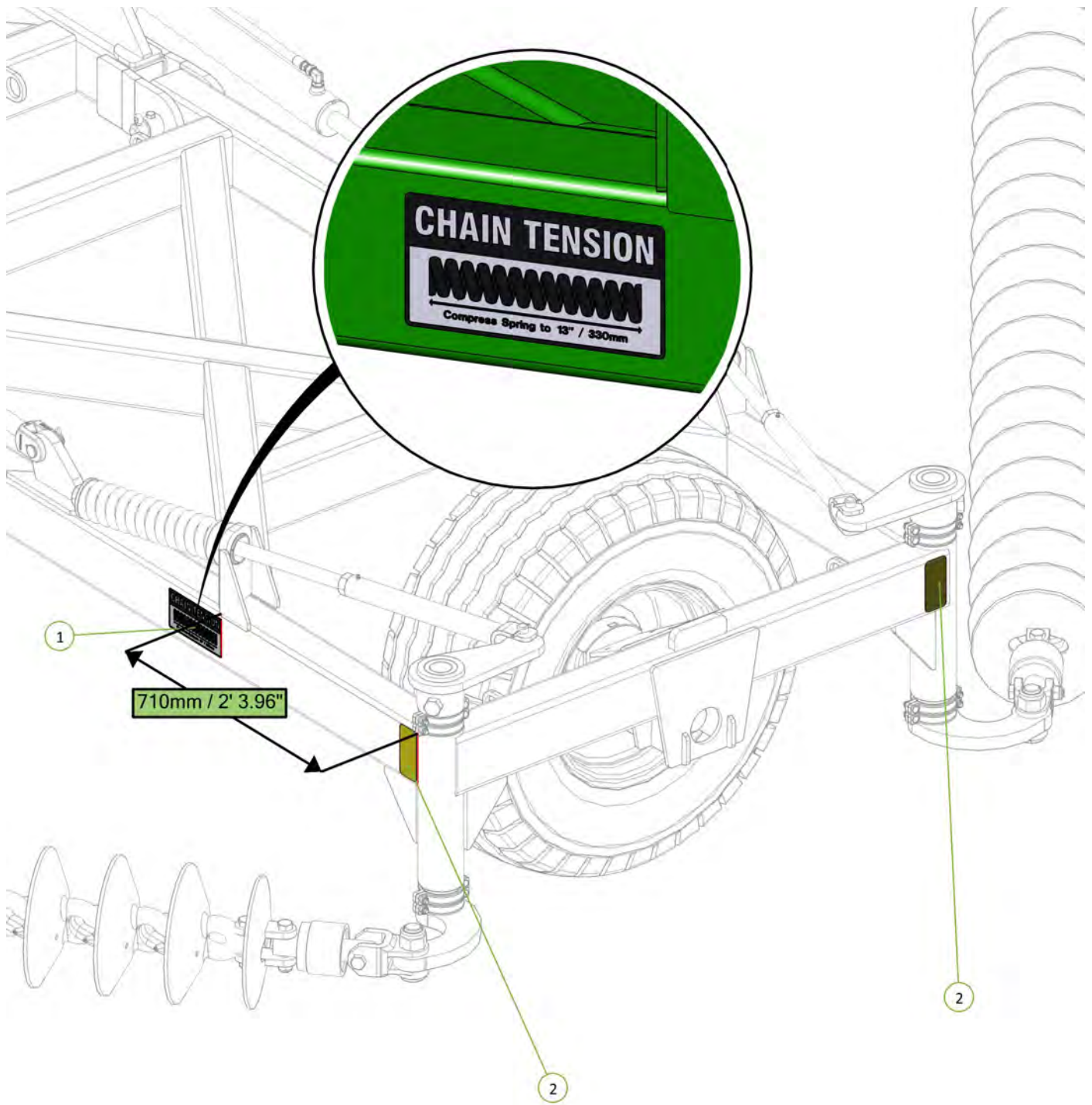

| Item No. | Description               | Number    | Qty |
|----------|---------------------------|-----------|-----|
| 1        | Chain Tension 330mm Decal | 0801-S15  | 1   |
| 2        | Yellow Reflective Decal   | 0801-SYRF | 2   |

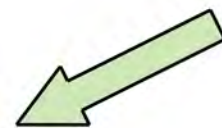

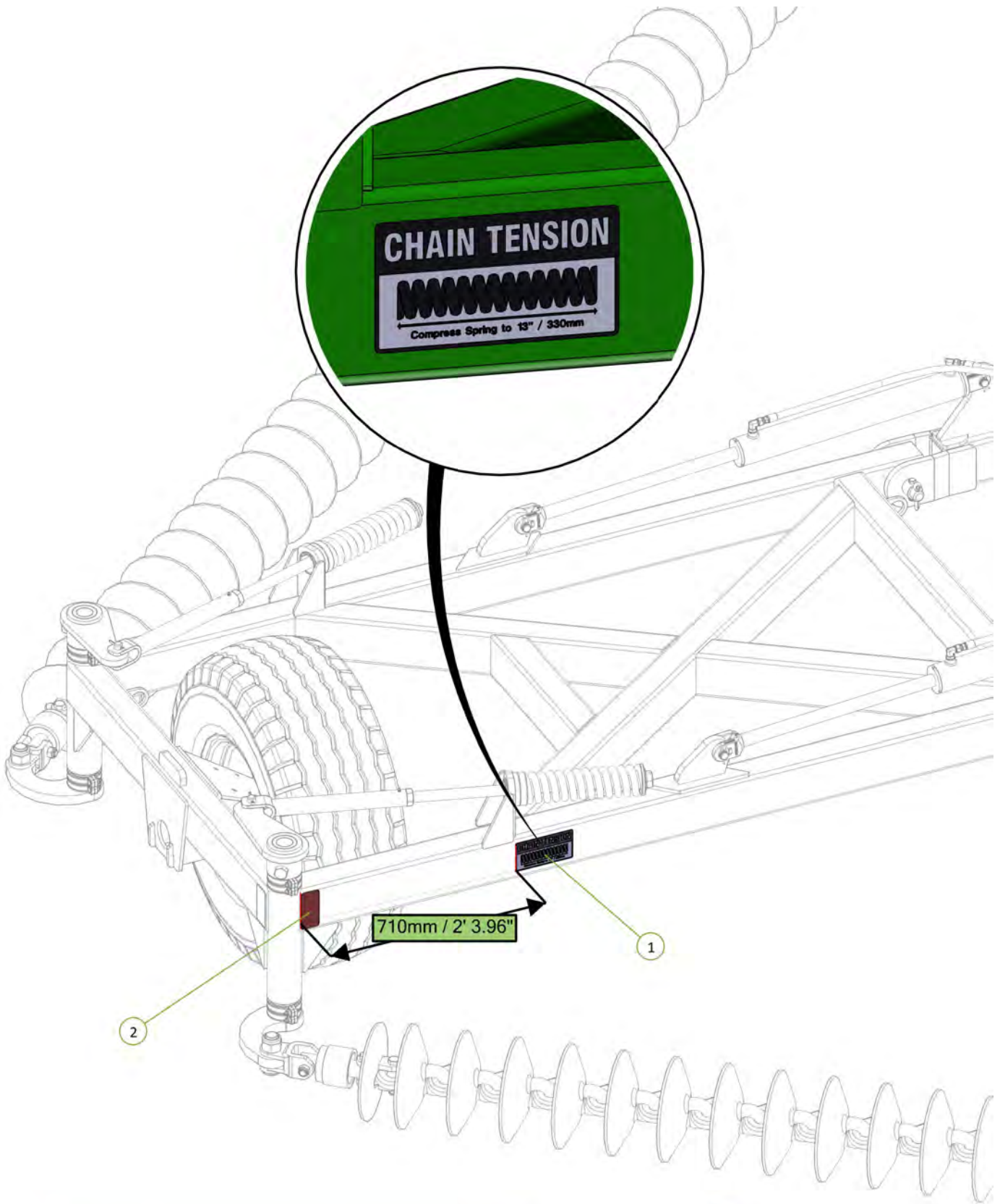

| Item No. | Description               | Number    | Qty |
|----------|---------------------------|-----------|-----|
| 1        | Chain Tension 330mm Decal | 0801-S15  | 1   |
| 2        | Red Reflective Decal      | 0801-SRRF | 1   |





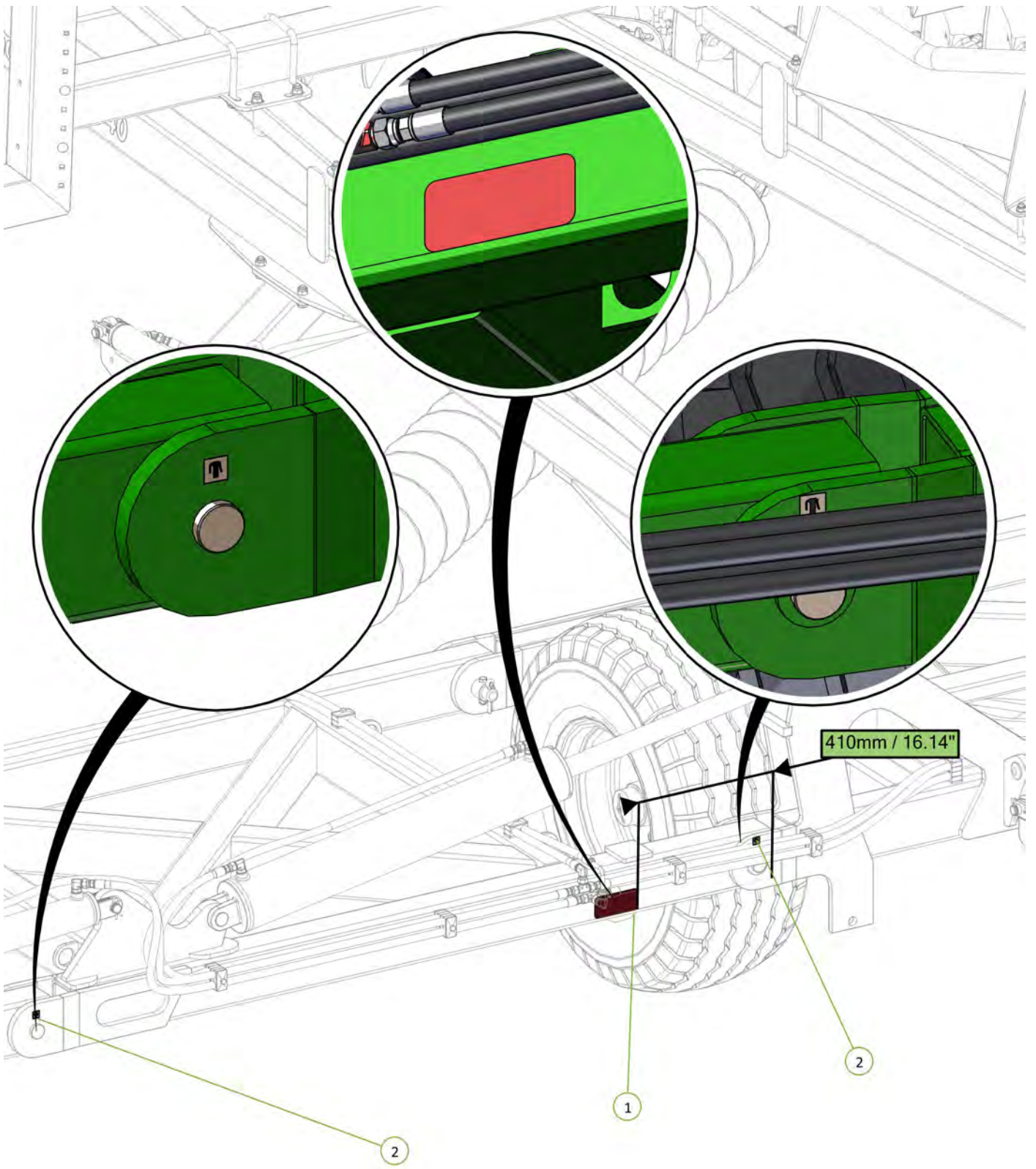

| Item No. | Description          | Number    | Qty |
|----------|----------------------|-----------|-----|
| 1        | Red Reflective Decal | 0801-SRRF | 1   |
| 2        | Grease Decal         | 0801-S10  | 2   |



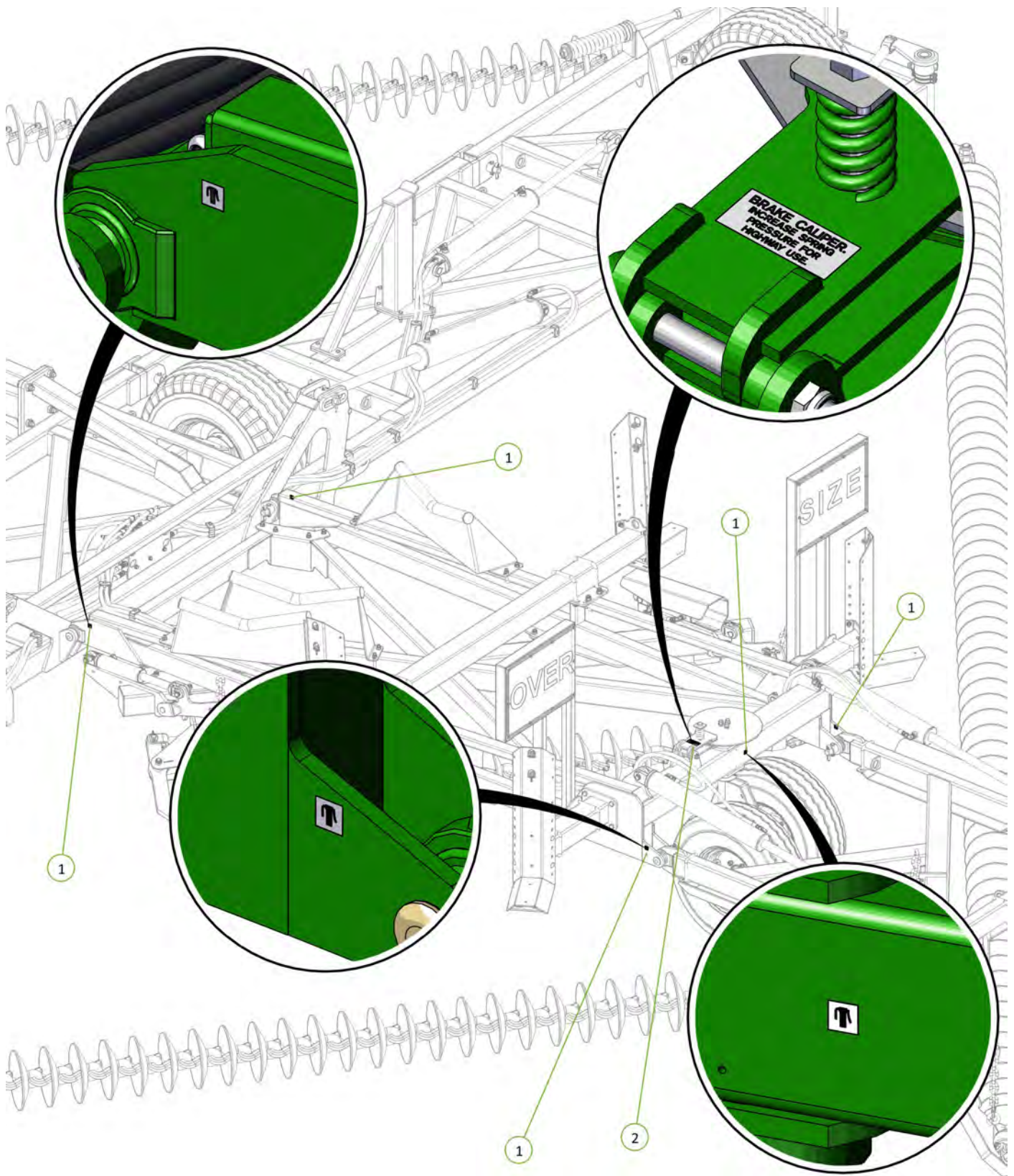

| Item No. | Description         | Number   | Qty |
|----------|---------------------|----------|-----|
| 1        | Grease Decal        | 0801-S10 | 5   |
| 2        | Brake Caliper Decal | 0801-S11 | 1   |



| Item No. | Description             | Number    | Qty |
|----------|-------------------------|-----------|-----|
| 1        | Yellow Reflective Decal | 0801-SYRF | 1   |

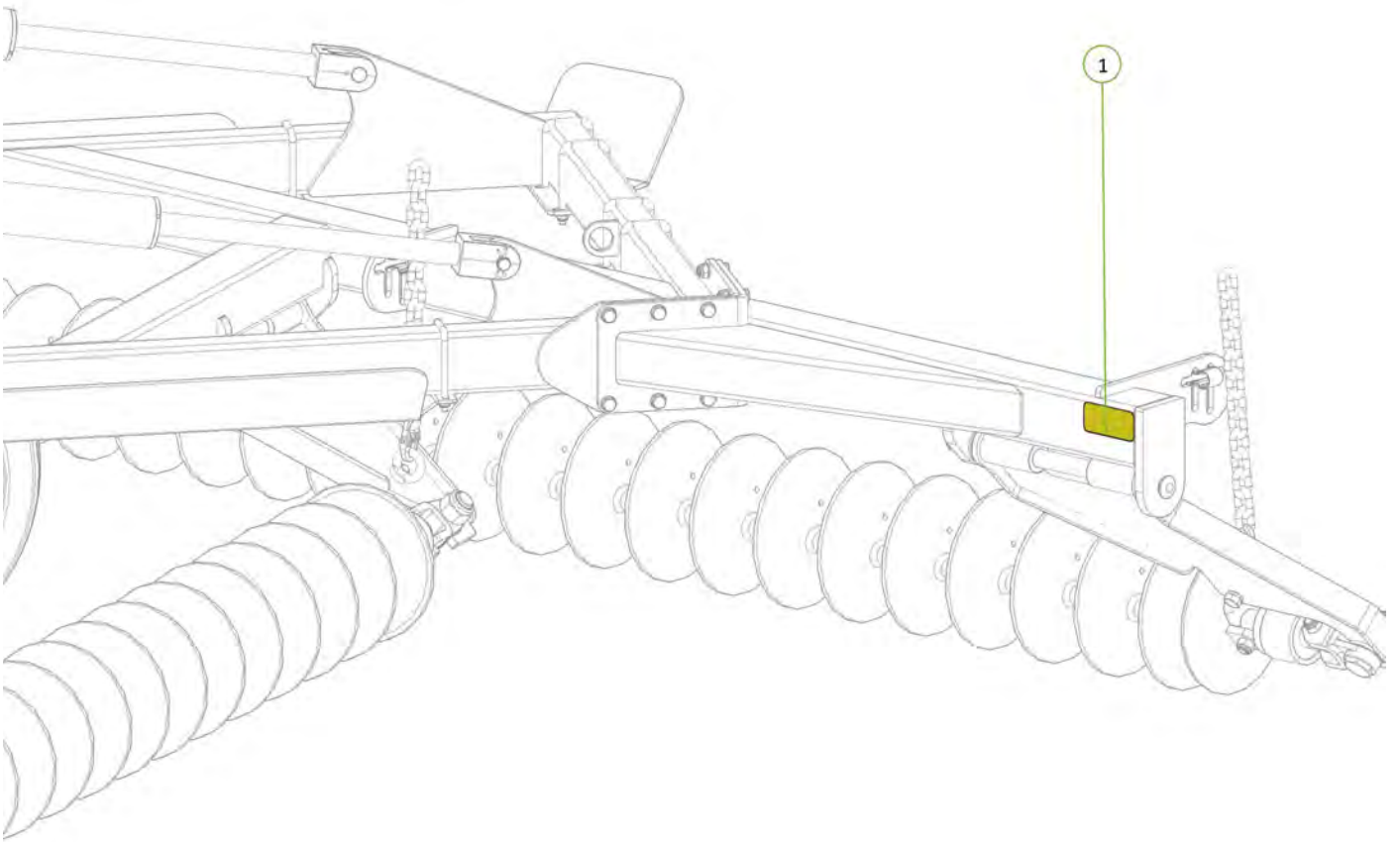



| Item No. | Description             | Number    | Qty |
|----------|-------------------------|-----------|-----|
| 1        | Yellow Reflective Decal | 0801-SYRF | 1   |

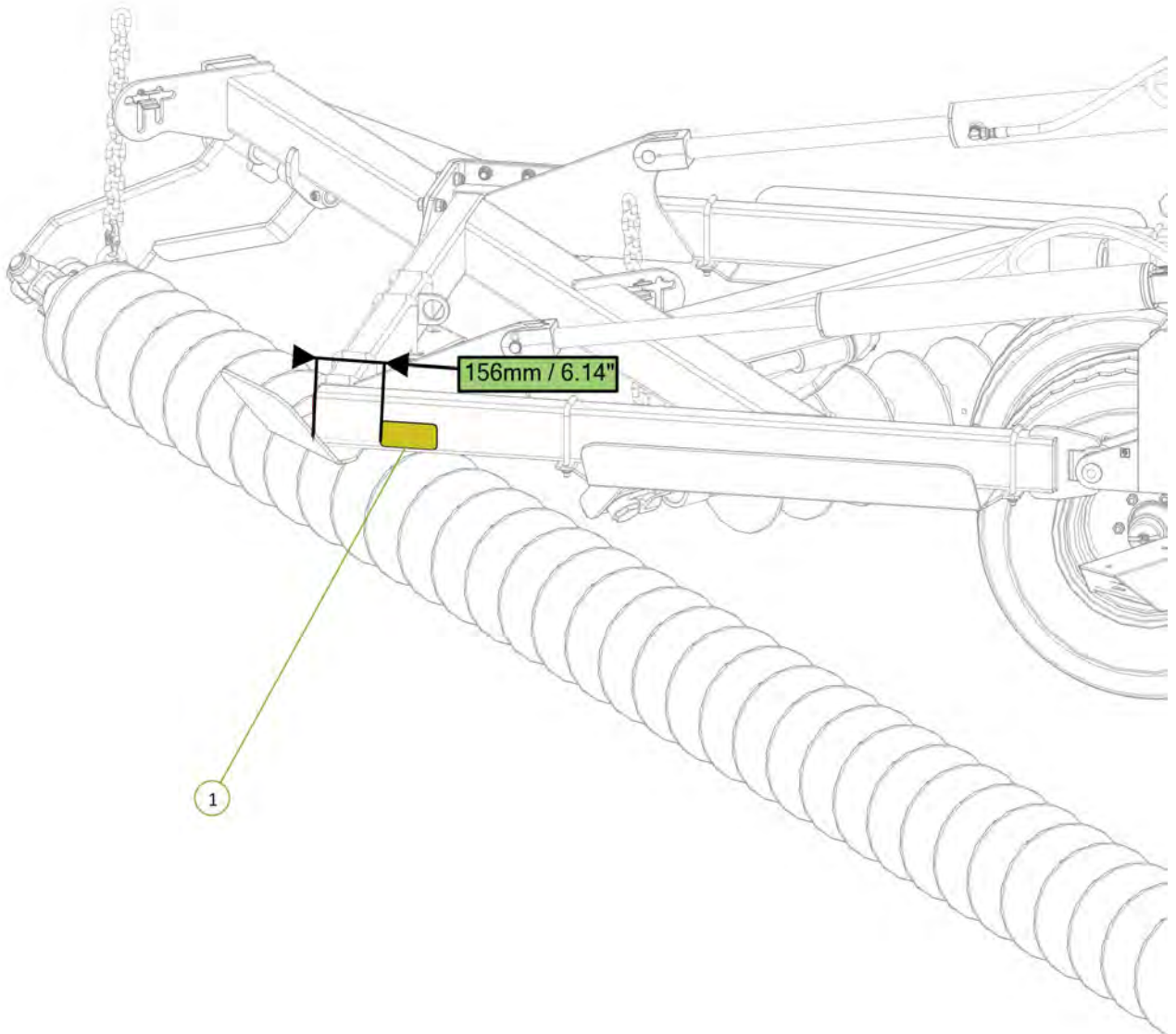

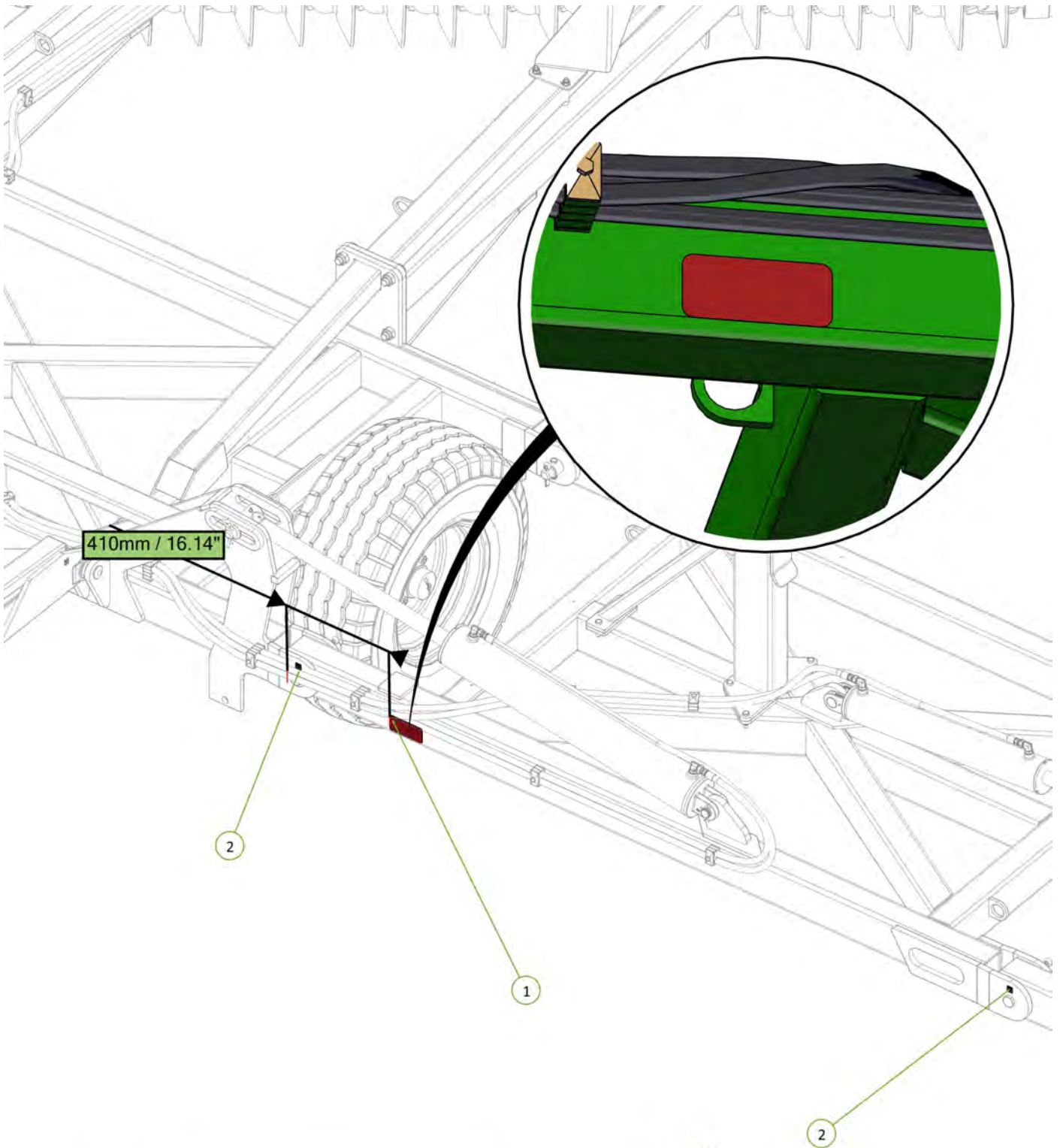

| Item No. | Description          | Number    | Qty |
|----------|----------------------|-----------|-----|
| 1        | Red Reflective Decal | 0801-SRRF | 1   |
| 2        | Grease Decal         | 0801-S10  | 2   |

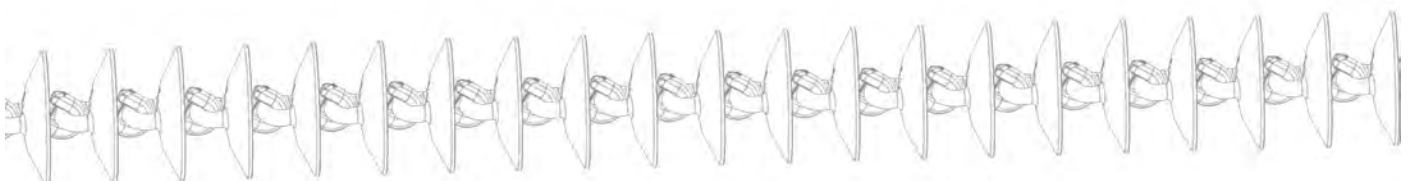

| Item No. | Description               | Number    | Qty |
|----------|---------------------------|-----------|-----|
| 1        | Chain Tension 330mm Decal | 0801-S15  | 1   |
| 2        | Red Reflective Decal      | 0801-SRRF | 1   |
| 3        | Yellow Reflective Decal   | 0801-SYRF | 1   |

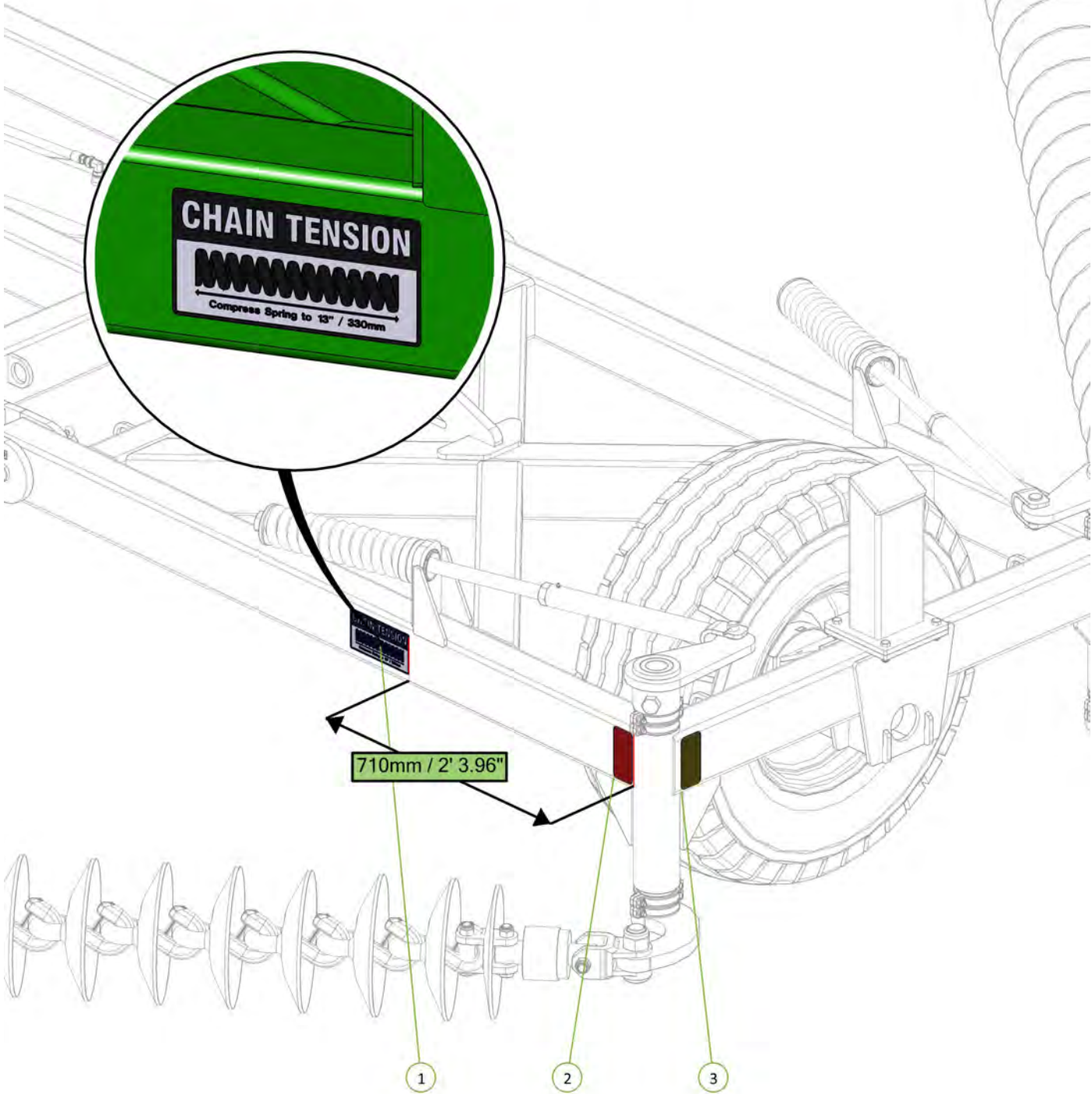



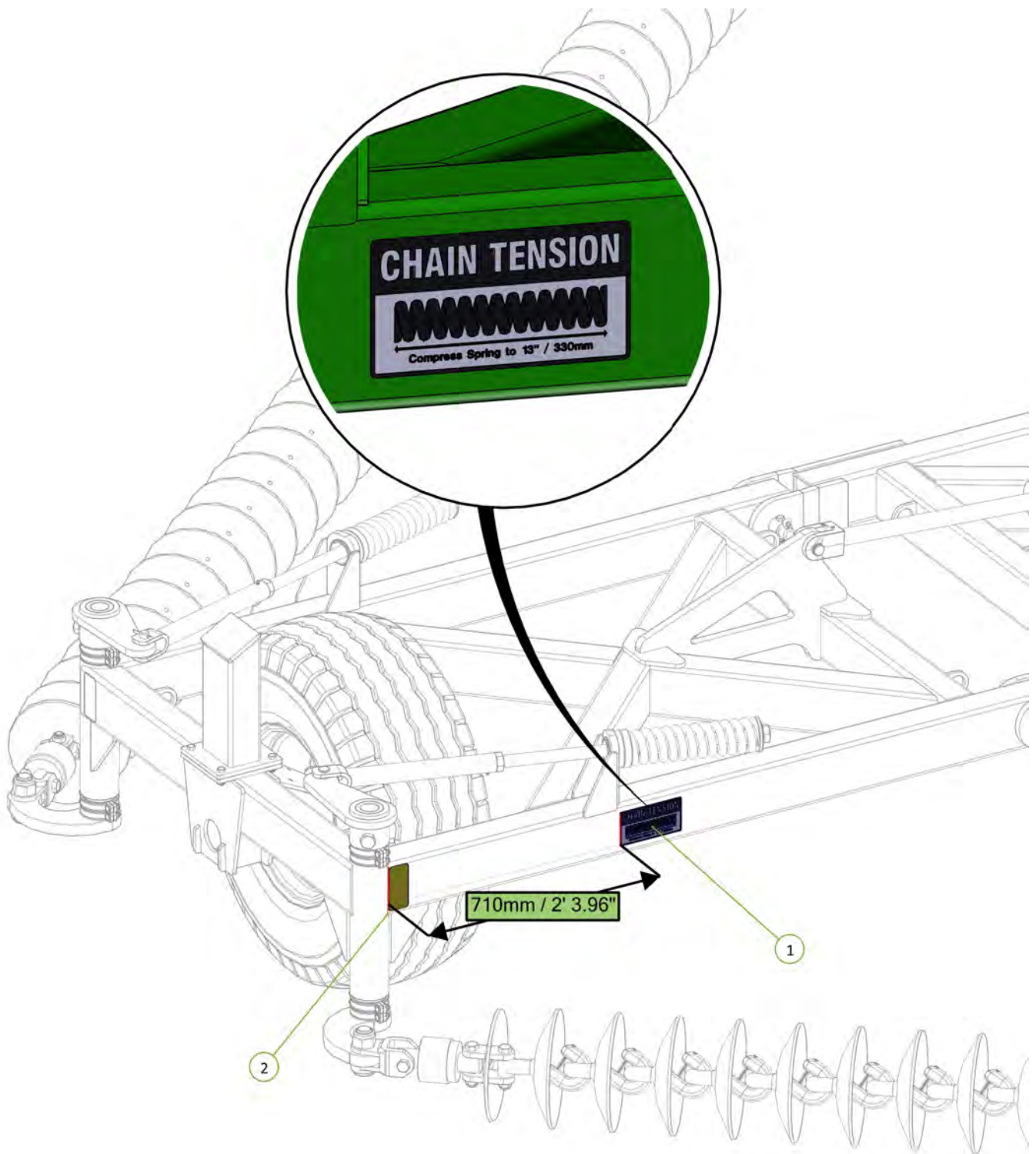

| Item No. | Description               | Number    | Qty |
|----------|---------------------------|-----------|-----|
| 1        | Chain Tension 330mm Decal | 0801-S15  | 1   |
| 2        | Yellow Reflective Decal   | 0801-SYRF | 1   |

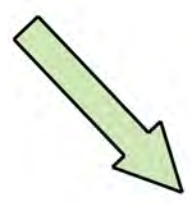

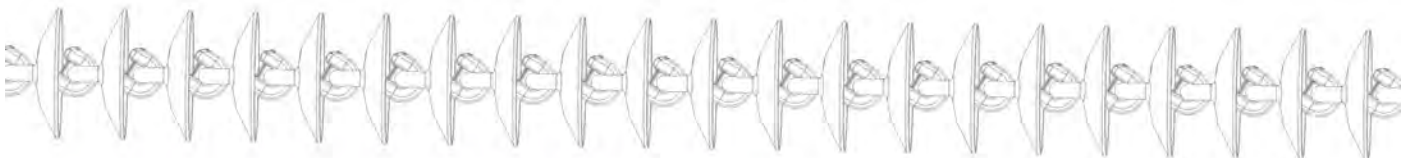
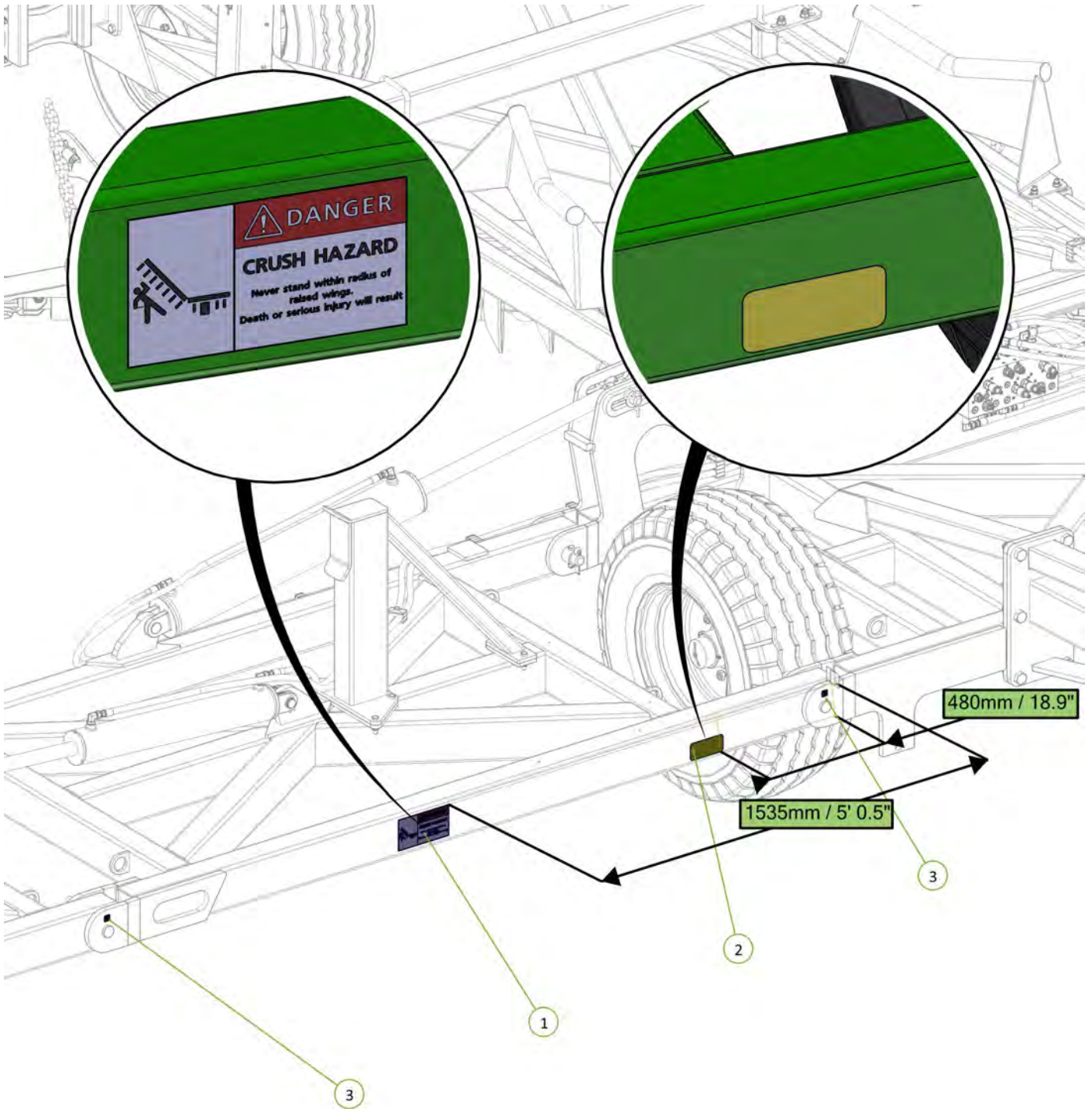

| Item No. | Description               | Number    | Qty |
|----------|---------------------------|-----------|-----|
| 1        | Danger Crush Hazard Decal | 0801-S3   | 1   |
| 2        | Yellow Reflective Decal   | 0801-SYRF | 1   |
| 3        | Grease Decal              | 0801-S10  | 2   |

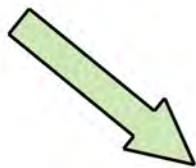

| Item No. | Description             | Number    | Qty |
|----------|-------------------------|-----------|-----|
| 1        | Yellow Reflective Decal | 0801-SYRF | 1   |

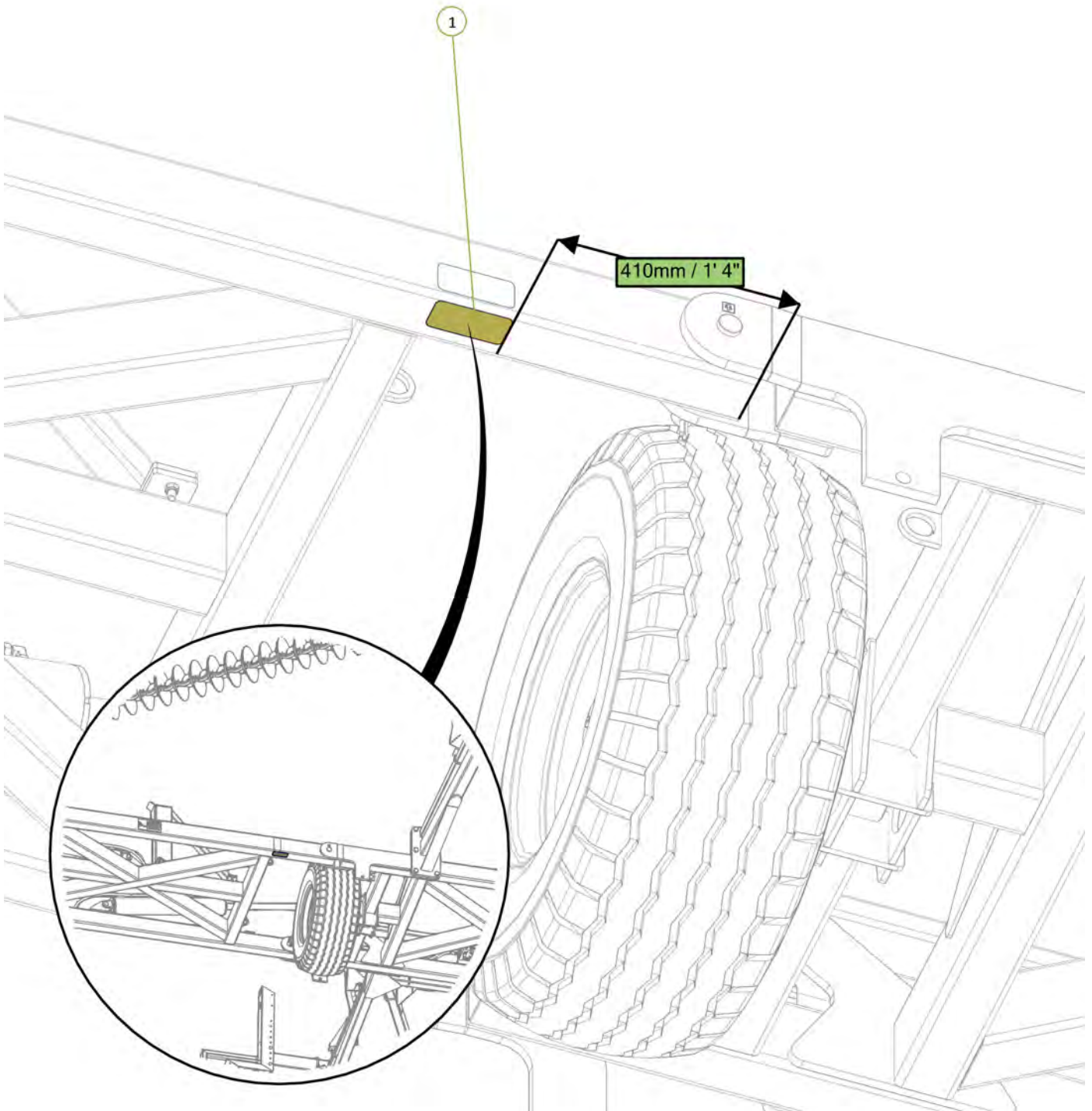



| Item No. | Description                      | Number             | Qty |
|----------|----------------------------------|--------------------|-----|
| 1        | Wheel Nut Decal                  | 0801-S9            | 4   |
| 2        | Decal, 15.0/70/18 Tyre Inflation | 0801-S8-15.5-70-18 | 4   |

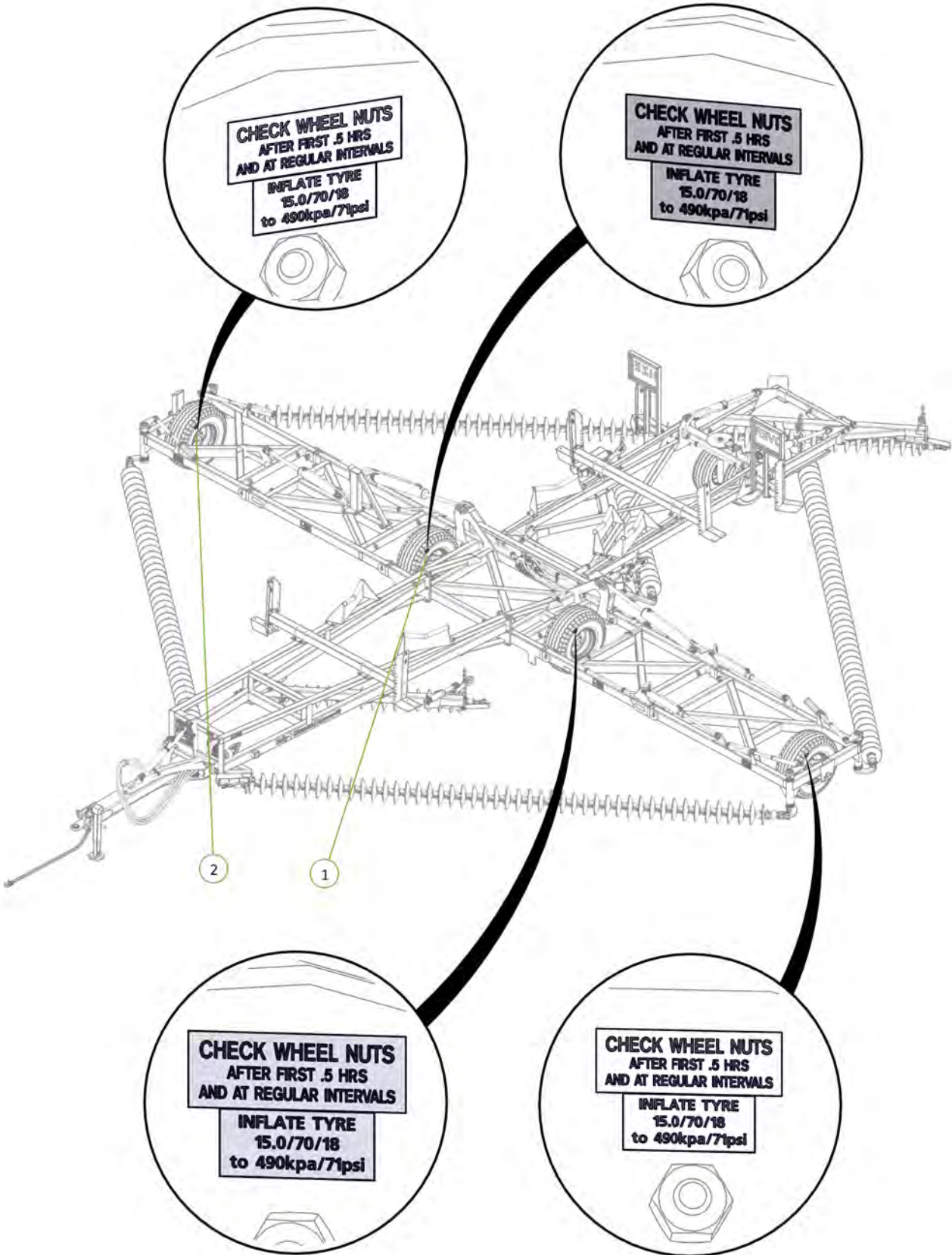

| Item No. | Description                  | Number             | Qty |
|----------|------------------------------|--------------------|-----|
| 1        | Decal, 11L-15 Tyre Inflation | 0801-S8-11L-15.JPG | 2   |
| 2        | Wheel Nut Decal              | 0801-S9            | 2   |

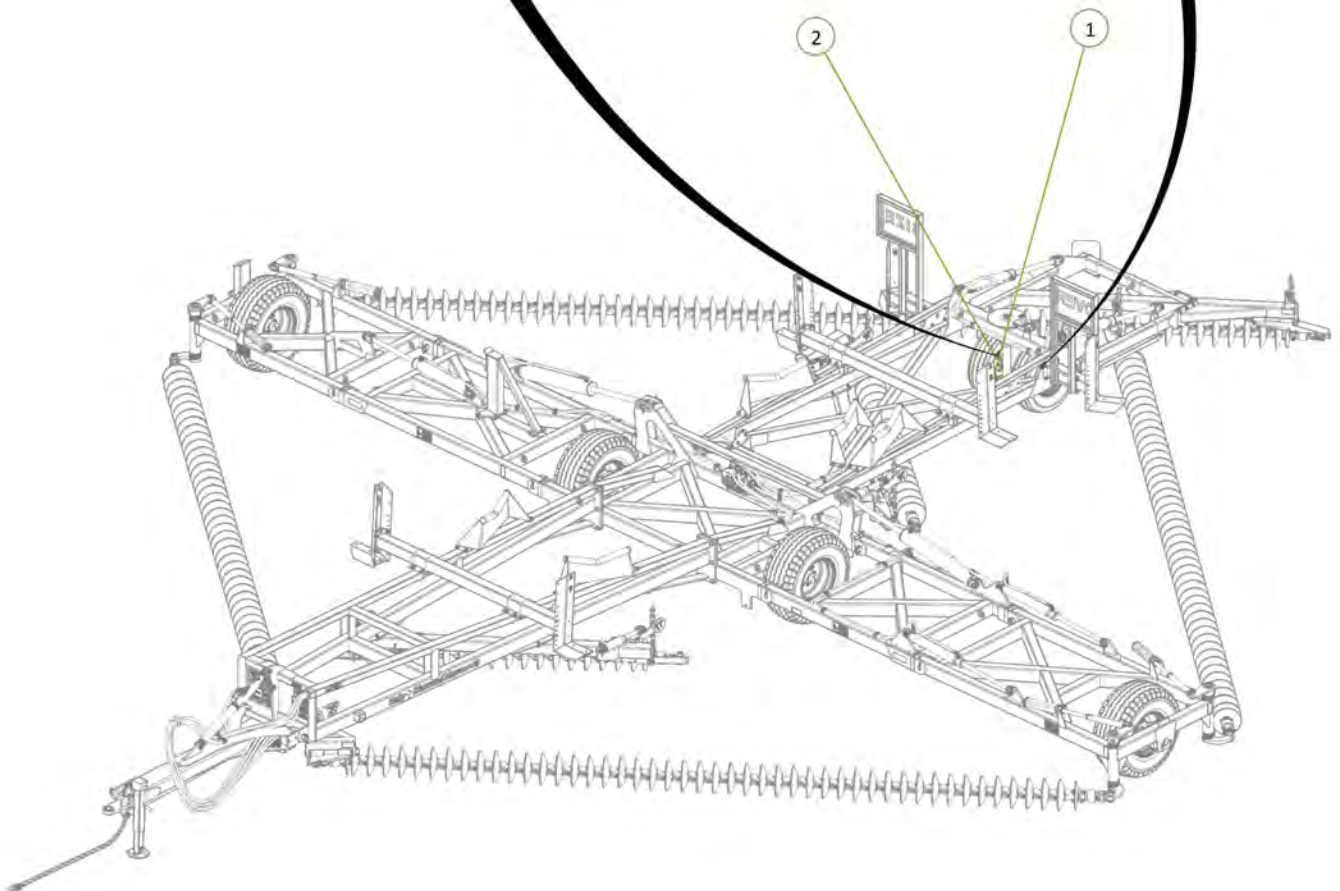
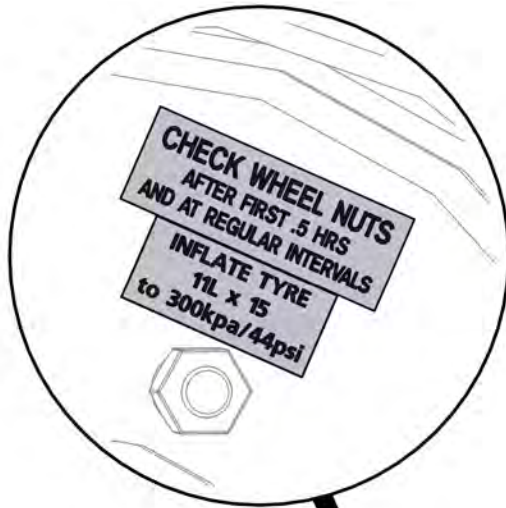

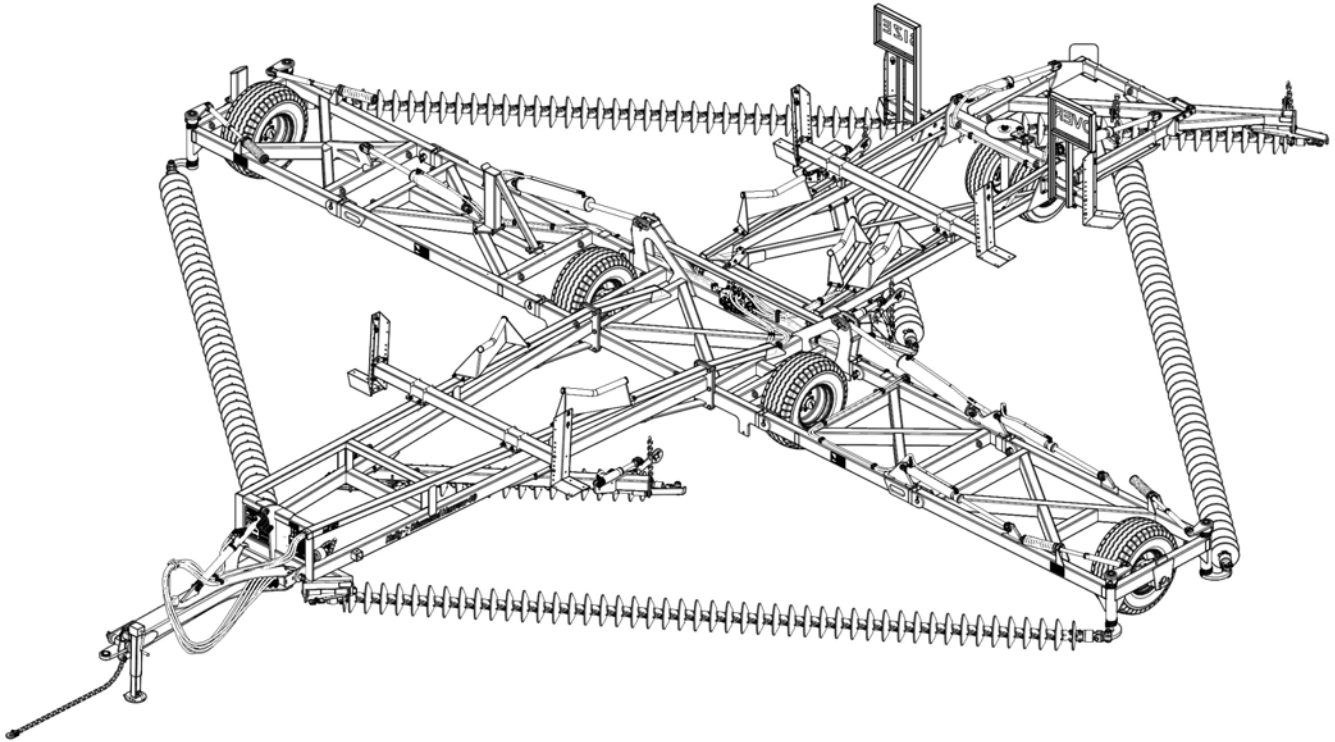



# Section 4

## Chain Assembly

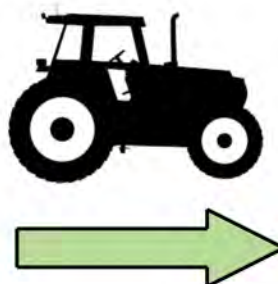
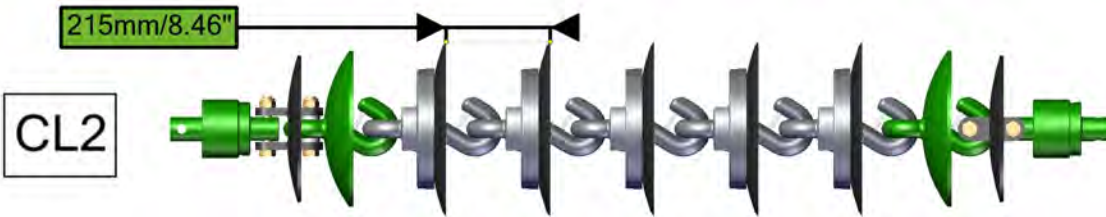

| Item No. | Description   | Number                      | Qty |
|----------|---|-----------------------------|-----|
| 1        | Nyloc Nut M20/24                                      | 0221-NYL20/24               | 4   |
| 2        | M20 x 110 / M24 x 120 grade 10.9 ZP Short Thread Bolt | 0211-20110ST/0211-24120ST   | 4   |
| 3        | 20/24mm Bolt Swivel Unit                              | 0802-PCHB55 / 0802-PCHB553  | 2   |
| 4        | Disc Chain Tie Plate Link 20mm / 24mm                 | 0802-DCTP-20 / 0802-DCTP-24 | 2   |
| 5        | Tie Plate Bush  | 0801-PCDCS55                | 2   |
| 6        | Roll Pin Zinc Plated 3/8" x 3"                        | 0262-3-8X3                  | 1   |
| 7        | CL1-B Chain Disc Link                                 | 0803-CL1                    | 1   |

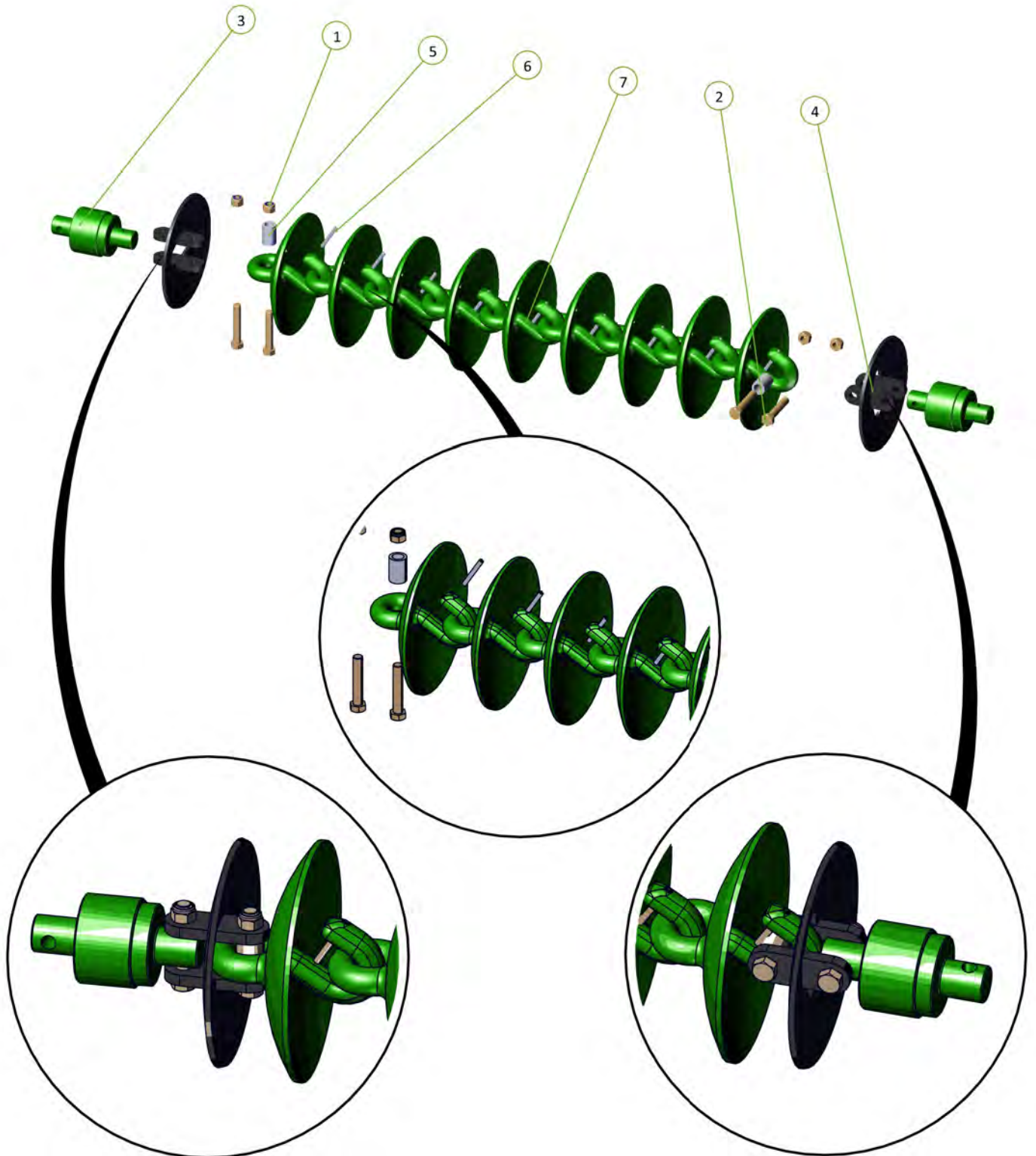
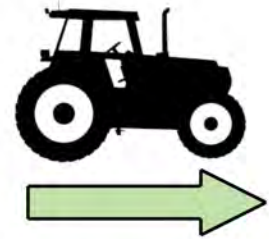



## Fitting Cast Link Pins

Please install cast link retaining Pins (3/8" x 3" Roll Pin, part number 0262-3-8X3) on all cast disc links. Failure to do this could lead to the discs becoming dislodged during transport causing severe damage or injury.

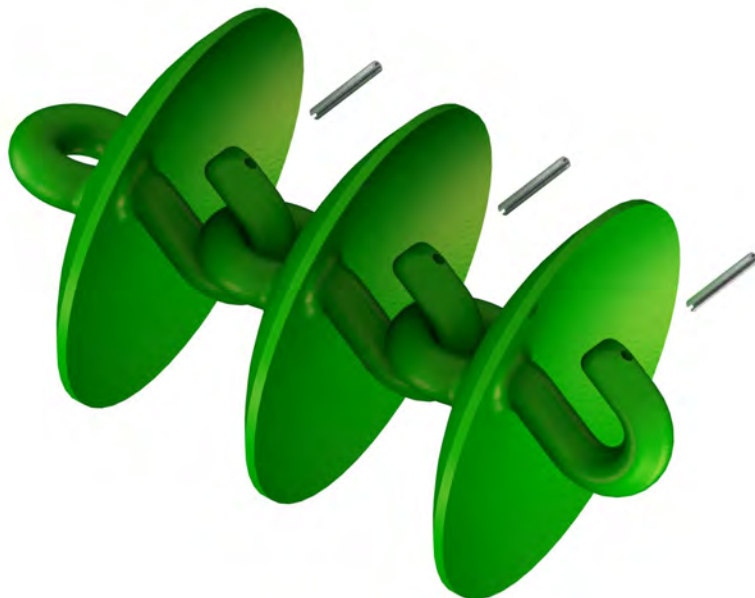
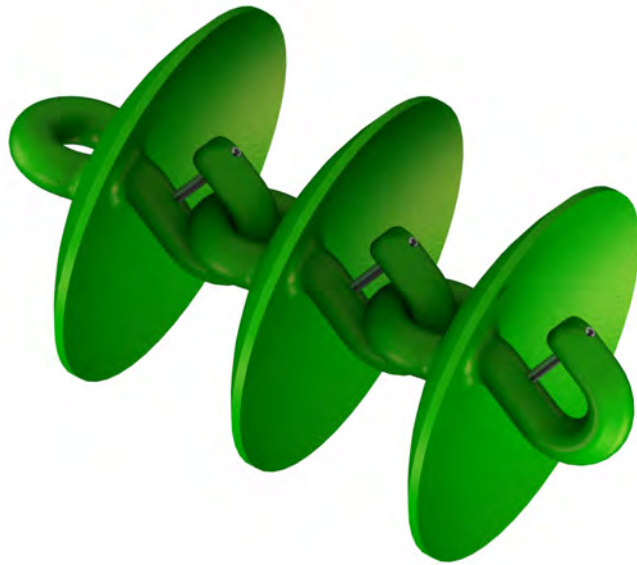

| Item No. | Description            | Number   | Qty |
|----------|------------------------|----------|-----|
| 1        | 0803-CL2-Link Assembly | 0803-CL2 | 1   |
| 2        | CL1-B Chain Disc Link  | 0803-CL1 | 1   |

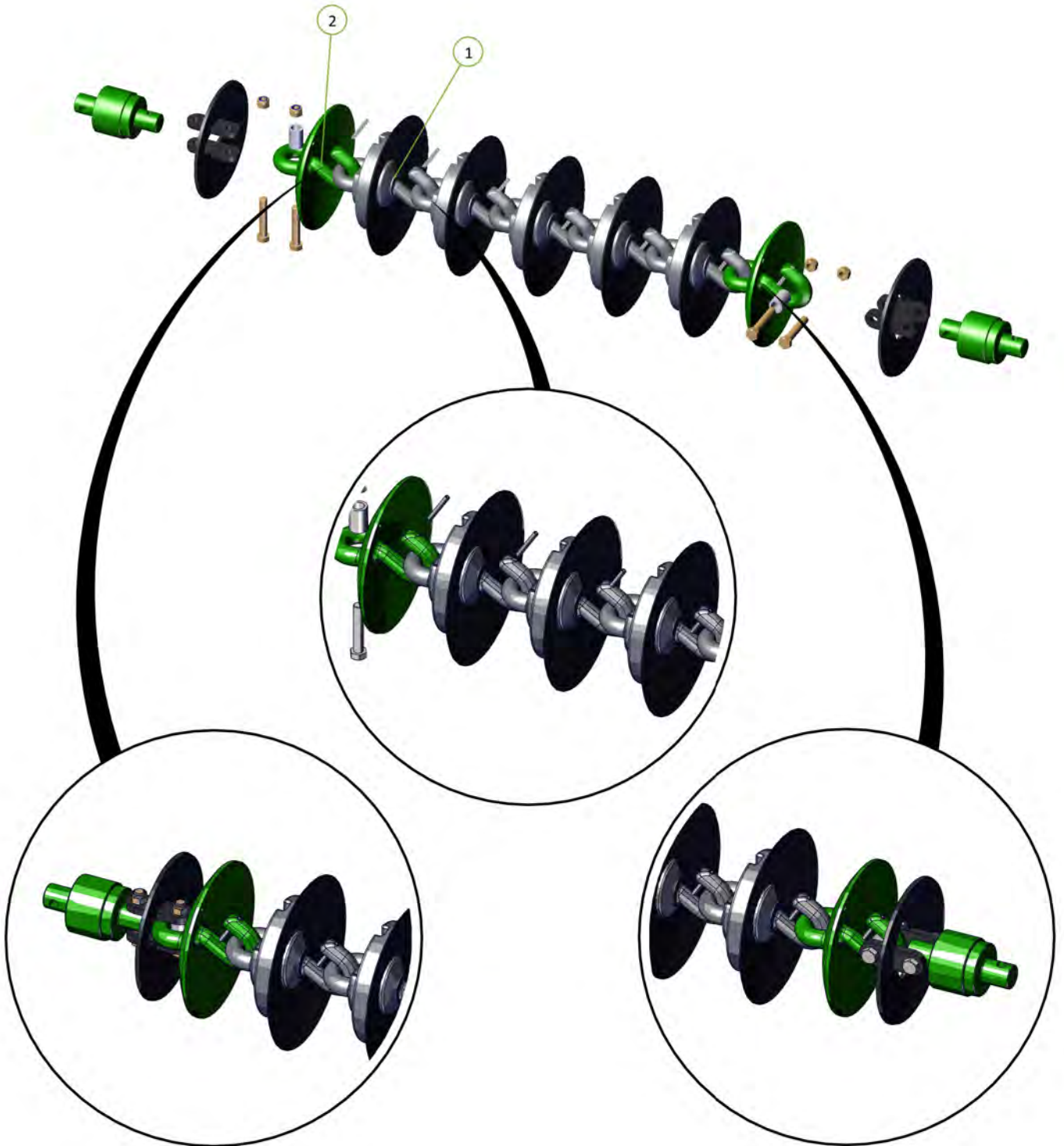

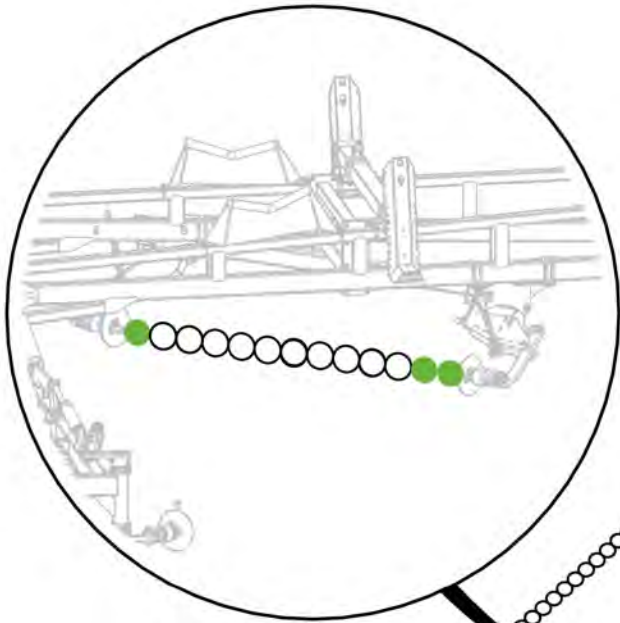

| Set           | CL2 | CL1 |
|---------------|-----|-----|
| Front Left    | 35  | 2   |
| Front Right   | 35  | 2   |
| Front Modules | 10  | 3   |
| Front Set     | 80  | 7   |
| Rear Right    | 34  | 14  |
| Rear Left     | 35  | 2   |
| Rear Modules  | 11  | 2   |
| Rear Set      | 80  | 18  |
| Total         | 160 | 25  |

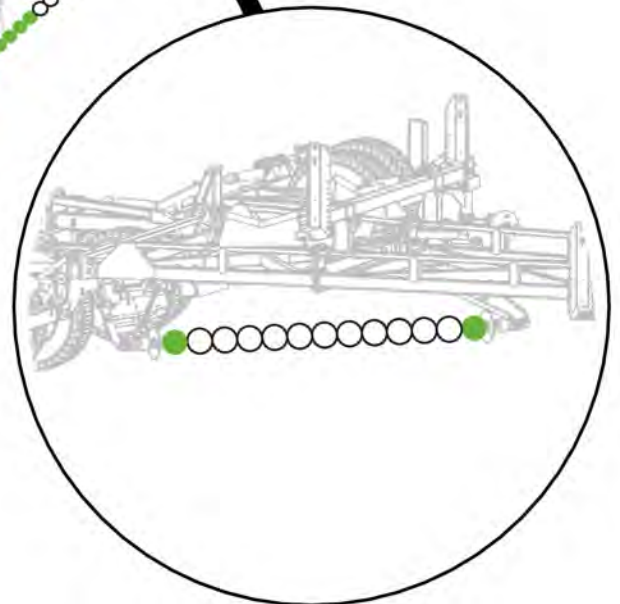
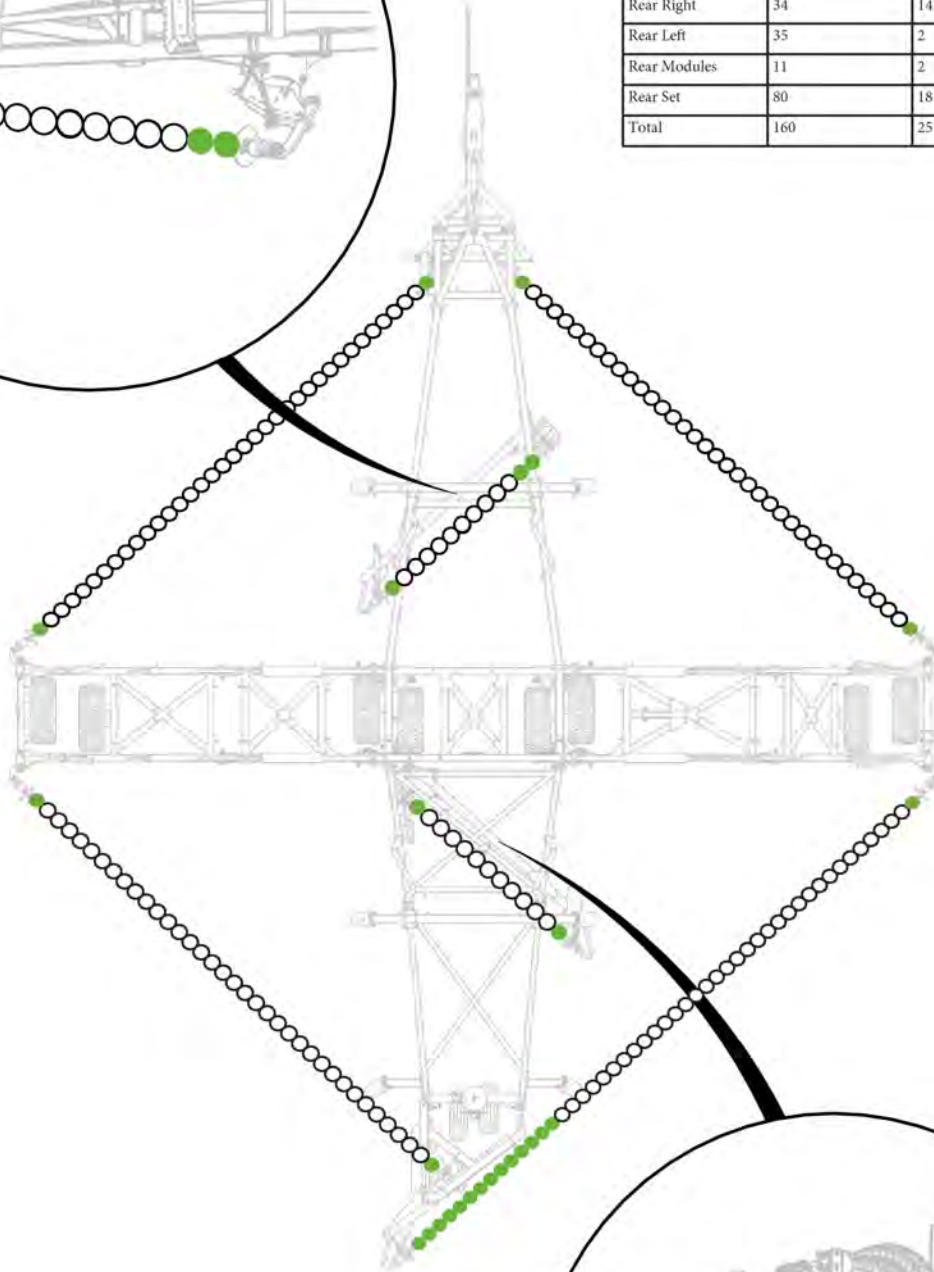



| Item No. | Description     | Number    | Qty |
|----------|-----------------|-----------|-----|
| 1        | R300 Chain Link | 0803-R300 | 1   |

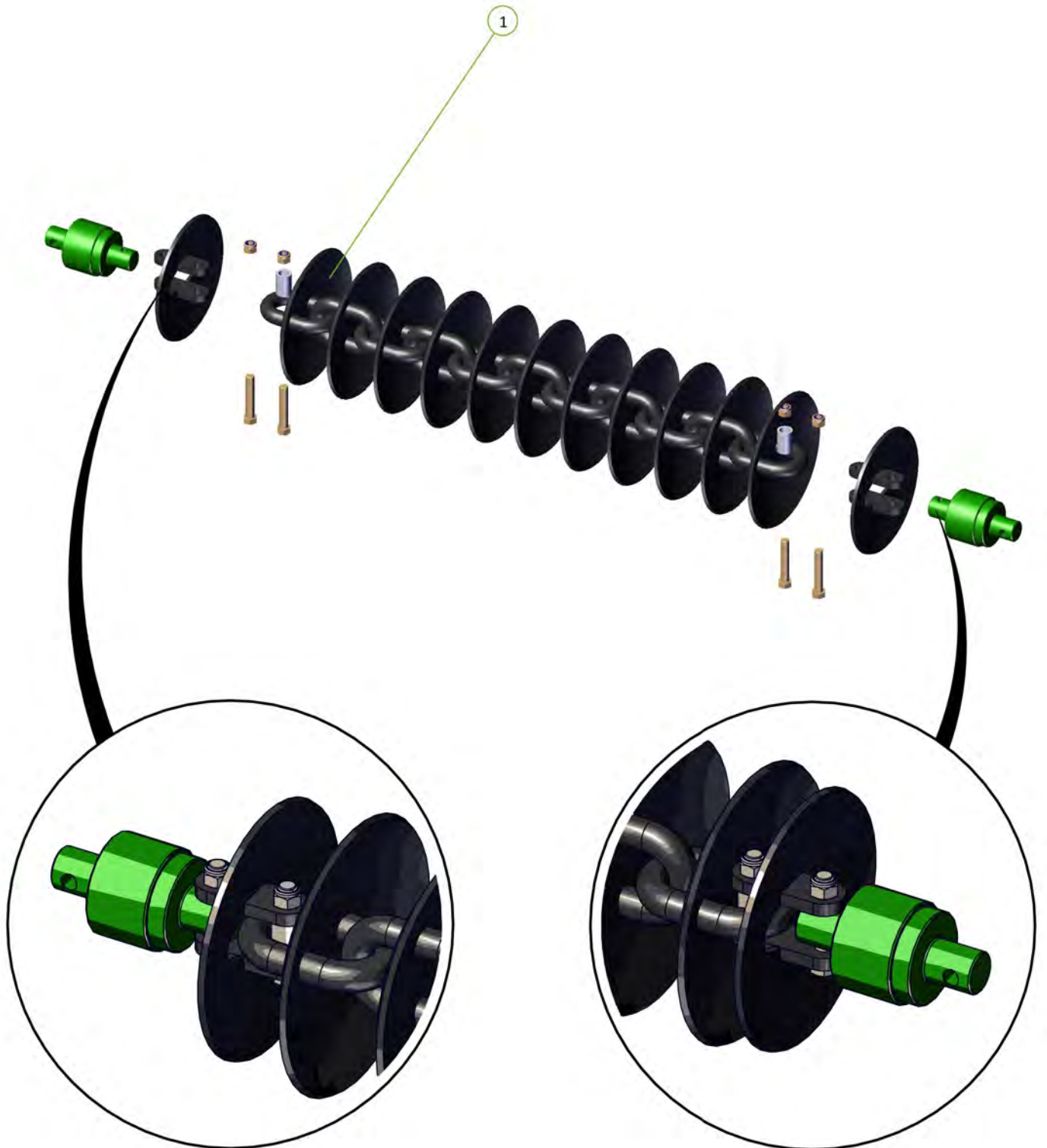
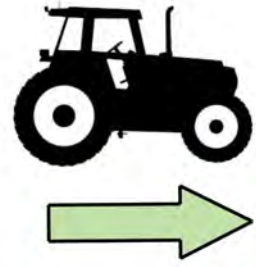

| Item No. | Description       | Number   | Qty |
|----------|-------------------|----------|-----|
| 1        | W36/25 Chain Link | 0803-W36 | 1   |

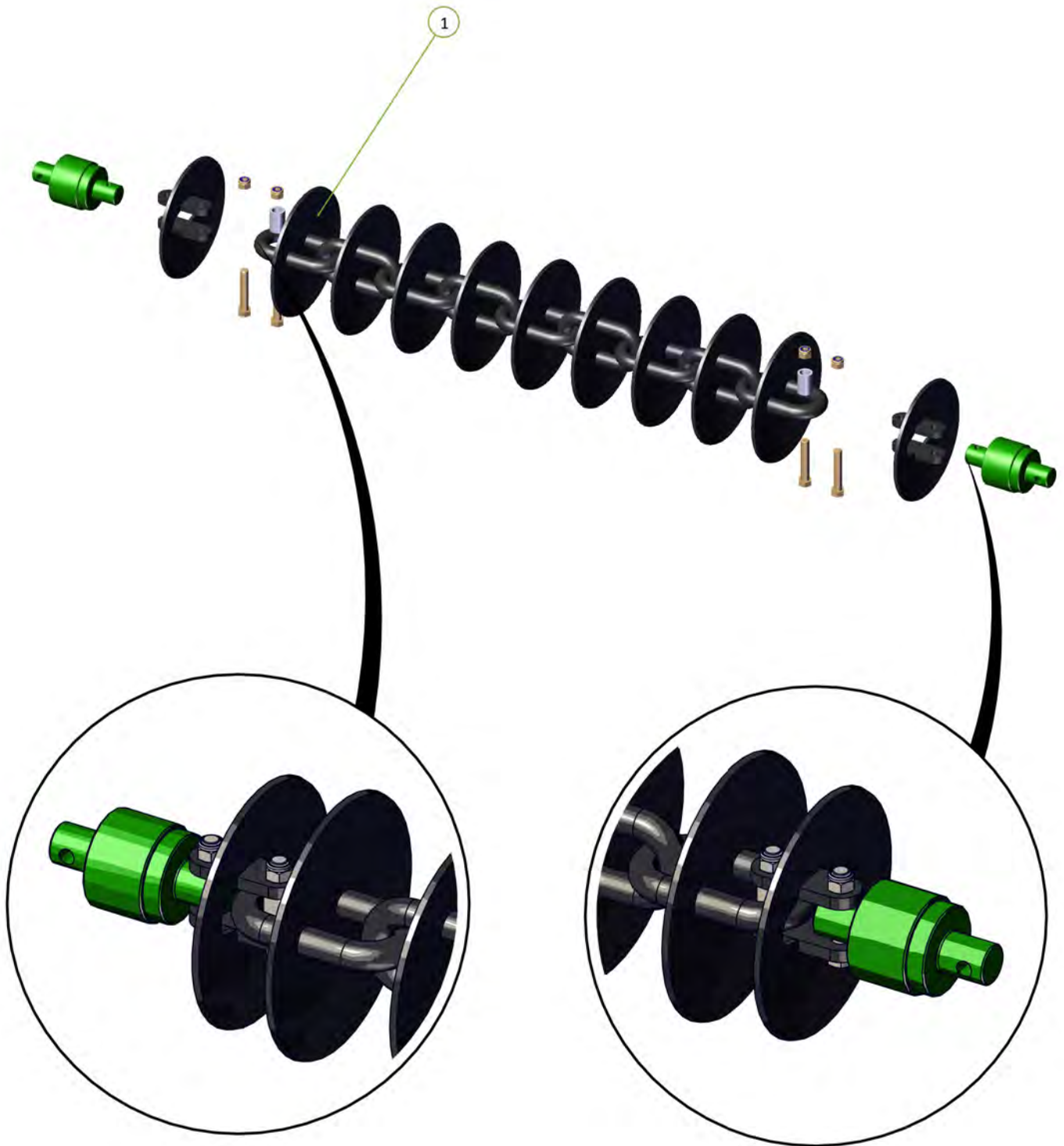
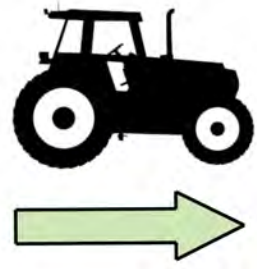

| Item No. | Description                                      | Number                | Qty |
|----------|--|-----------------------|-----|
| 1        | 10 Spike Disc Chain 49/27/5                      | 0803-SD49             | 1   |
| 2        | Tie Plate For 20mm Bolt/ Tie Plate For 24mm Bolt | 0800-83.2 / 0800-83.3 | 4   |

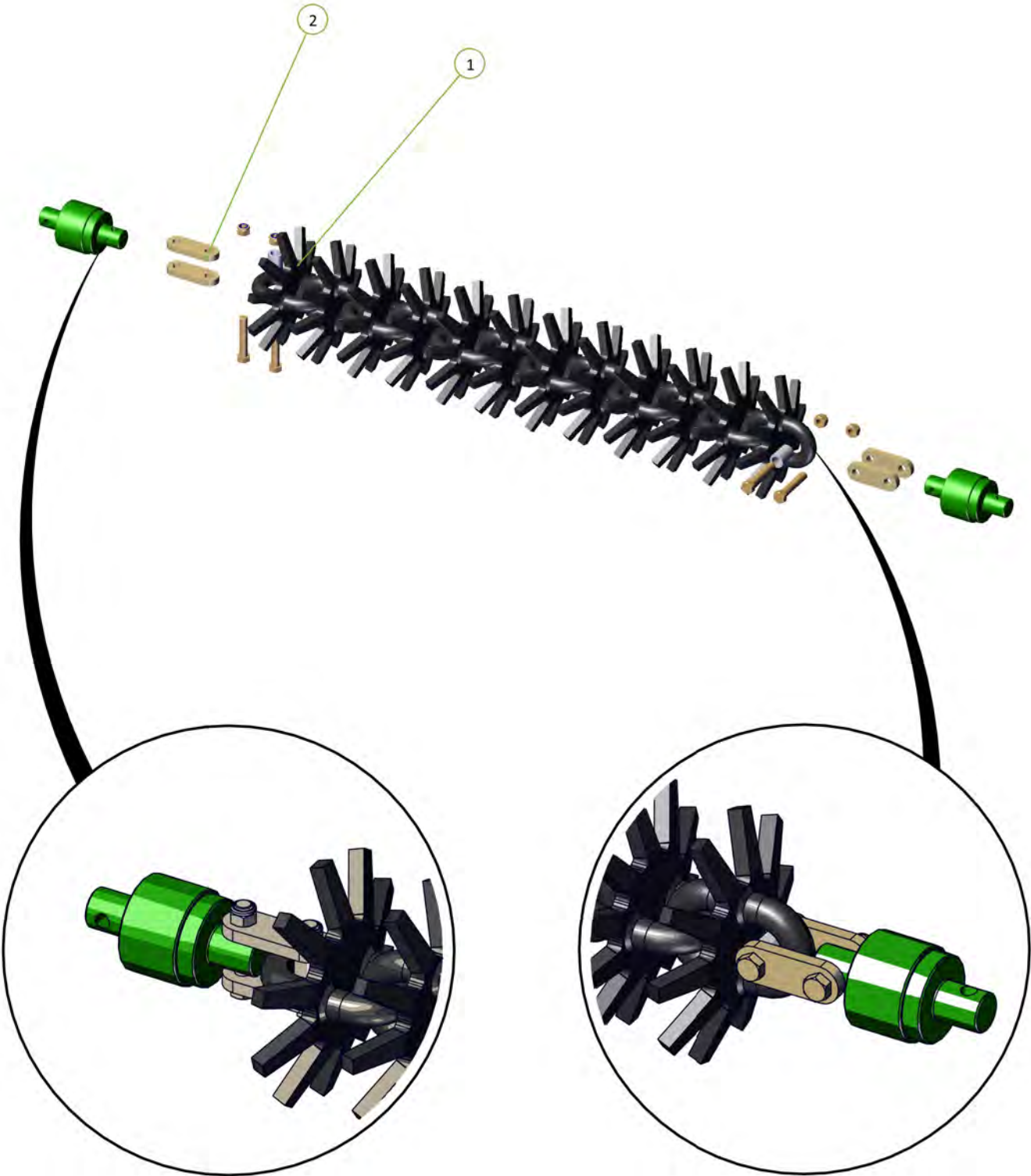



| Item No. | Description        | Number   | Qty |
|----------|--------------------|----------|-----|
| 1        | Prickle Chain Link | 0803-PCH | 1   |

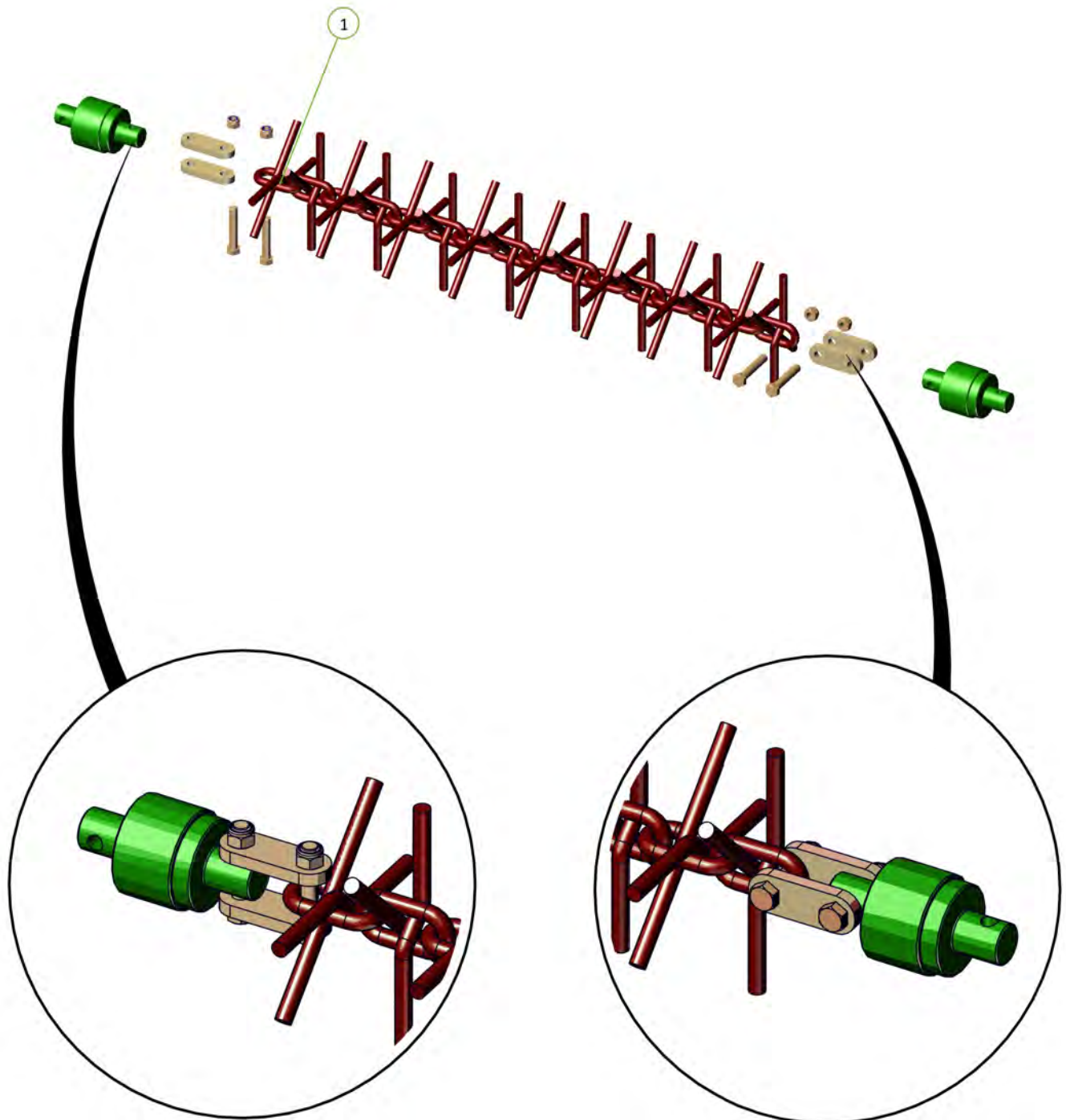

# Section 5

Diagrams and Charts

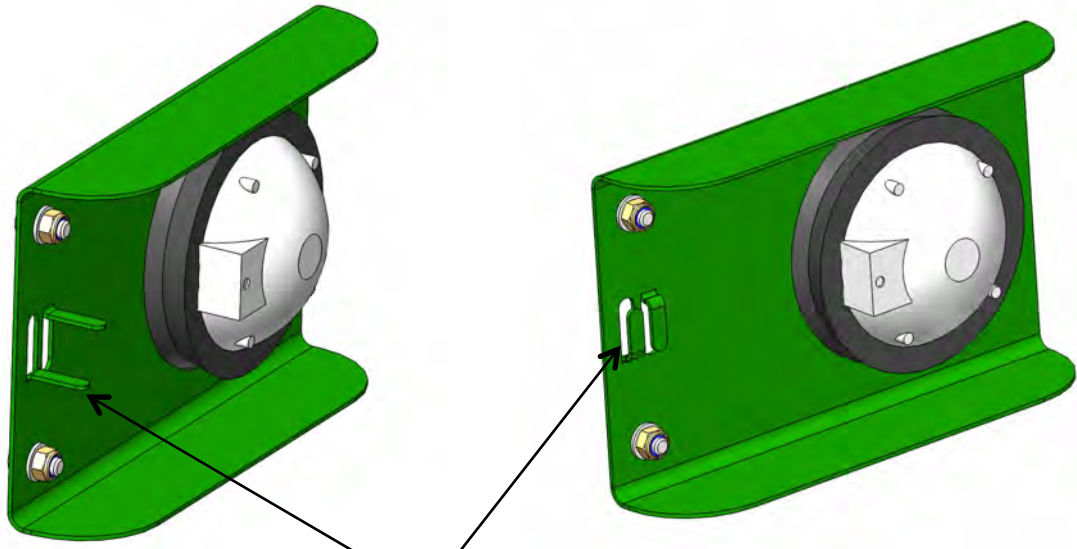

Please ensure to bend tabs up and feed wire through, so the light cable is secure

Mount to chain carrier with 2x M8x20 cup head bolts, Flat washer and Nylon nut

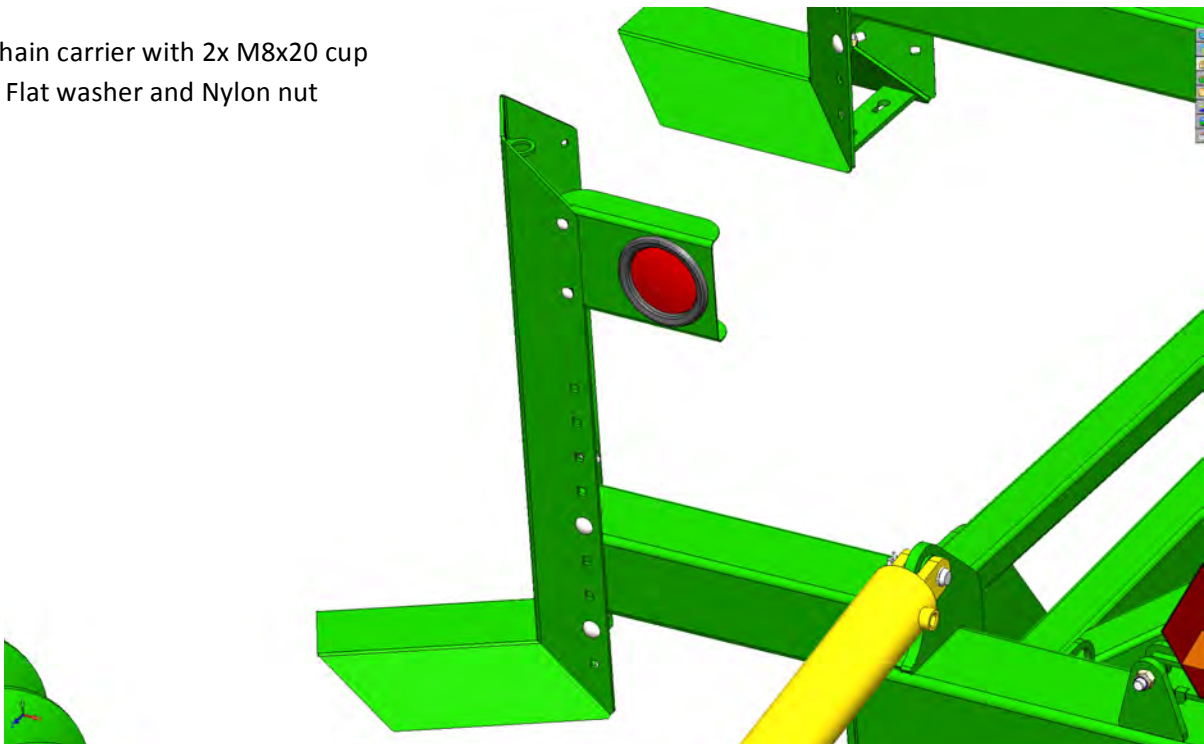



# Wiring Diagram

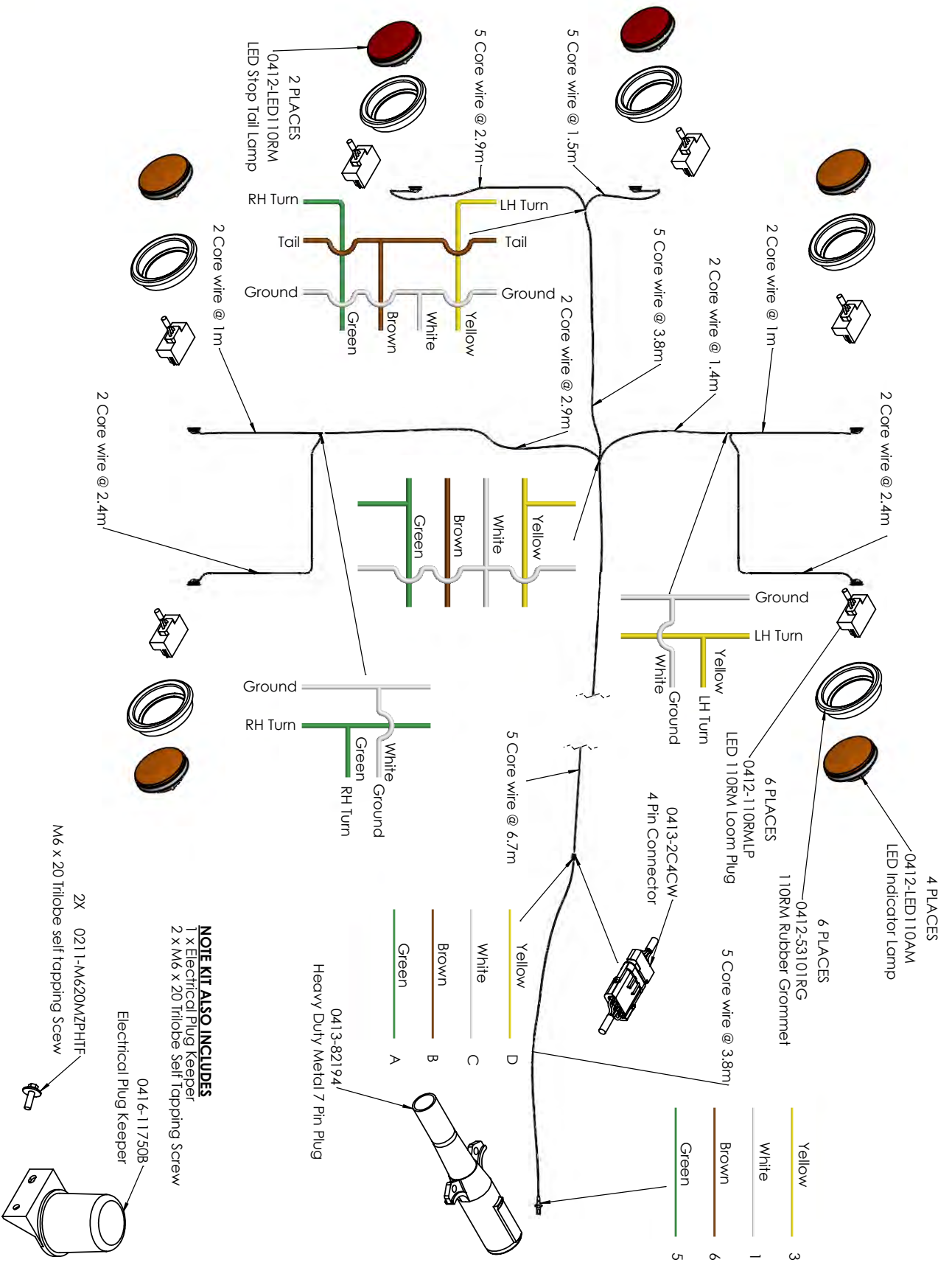

## Operating speeds

| Operating speeds for normal conditions |                       |
|--|-----------------------|
| Chain type                             | Speed                 |
| Prickle Chain                          | 6-10 Mph / 10-16 kmph |
| Disc Mulch Chain                       | 6-8 Mph / 10-12 kmph  |
| Transport / towing on roads            | 15 Mph / 25 kmph      |

## Tire pressure

| Tire size     | Ply | PSI | KPA |
|---------------|-----|-----|-----|
| 16.5L x 16.1  | 14  | 36  | 250 |
| H40 x 14.5-19 | 26  | 60  | 410 |
| 11L - 15      | 10  | 44  | 300 |
| 15.5/80/24    | 16  | 58  | 400 |
| 16.5/85/24    | 16  | 55  | 380 |
| 550/60/22.5   | 16  | 40  | 280 |
| 400/60/22.5   | 16  | 50  | 350 |
| 12.5/80/18    | 14  | 85  | 590 |
| 15.0/70/18    | 14  | 71  | 490 |

## Chain Harrow specifications

|                         |                |
|-------------------------|----------------|
| <b>Model</b>            | <b>40'/12m</b> |
| <b>Working width</b>    | 43'4"/13.2m    |
| <b>Transport width</b>  | 11'6"/3.5m     |
| <b>Transport height</b> | 12'2"/3.7m     |
| <b>Transport length</b> | 52'6"/14.3m    |

## Disc Chain lengths

| Model 40ft |               | Length     | CL2   | CL1 | W36 | R300 | SD49 | Prickle chain |
|------------|---------------|------------|---|-----|-----|------|------|---------------|
|            |               |            | CL2 disc chain also requires CL1 disc chain |     |     |      |      |               |
| <b>40'</b> | Front right   | 25'/7.6m   | CL2 - 32<br>CL1 - 2                         | 46  | 46  | 60   | 60   | 84            |
|            | Front left    | 25'/7.6m   | CL2 - 32<br>CL1 - 2                         | 46  | 46  | 60   | 60   | 84            |
|            | Rear right    | 29.8'/9.1m | CL2 - 32<br>CL1 - 14                        | 57  | 60  | 79   | 79   | 109           |
|            | Rear left     | 25'/7.6m   | CL2 - 33<br>CL1 - 2                         | 45  | 47  | 62   | 62   | 87            |
|            | Modules front | 8.9'/2.7m  | CL2 - 10<br>CL1 - 2                         | 17  | 17  | 22   | 22   | 31            |
|            | Modules rear  | 8.9'/2.7m  | CL2 - 11<br>CL1 - 2                         | 16  | 17  | 22   | 22   | 31            |



# Section 6

Operation

## Basic Operation

### Unfolding:

1. Walk around and inspect the machine.
  - a. Check that chains are not hooked on framework
  - b. Check swivel bolts are in place and not broken
  - c. Check th at height adjusting chains have not fallen out of their slotted plates during transport.
  - d. Ensure front lift cylinder depth stops are fully engaged on cylinder shaft.
2. Lower front A frame to working height.
3. Unfold wings holding the hydraulic lever until both the main center cylinder pins have centered in their slots. (If chain pulls tight during unfold, stop and inspect if chain is hooked)
4. Lower rear tail by holding hydraulic lever until tail and modules are completely lowered to working position.
5. Walk around and check that all chain links are straight and that working height of all swivels is correct for field conditions. Adjust if necessary.
6. Move off with all chains in working position. If necessary it is acceptable to raise front A pull to transport height. This will lift the front chains off the ground and reduce the load on the tractor. Lower the front A pull once moving satisfactorily.

### Folding:

1. Lower the front A frame to working height. (This is important to ensure that all chains locate correctly in their transport rests).
2. Raise the Rear Tail and modules by holding the hydraulic lever until they come to a complete stop.
3. Fold the wings. They should move as follows; main center cylinders will retract, one or both, until the wings stand vertically. The left outer wing then the right outer wing will fold down.
4. Raise front A frame to transport height.
5. Walk around and check that chains have located correctly in transport rests.

**(30' only, close wing transport lock valves).**

## Setting for correct chain tension

### Wings

Use the spanner supplied. Loosen the lock nut adjacent to the tensioner assembly body. Turn the tension bolt clockwise to compress the coil spring. Correct tension is achieved when spring retains its set length when operator rolls the chain fore and aft on the ground. Retighten the lock nut.

See table below

### Spring Compression Length

| Model | inches | mm  |
|-------|--------|-----|
| 40    | 12.4   | 330 |

When less than 4" (100mm) of thread remains visible on the adjustor bolt then a link must be removed from the chain



## Modules

Loosen the lock nut on the draw bolt.

Tighten the adjusting nut clockwise until the outer face of the spring retaining washer is flush with the body of the module tensioning unit.

Retighten the lock nut.

If more than 8" (200mm) of thread is exposed then a link should be removed to maintain correct adjustment.



## Importance of chain tension

### Operational

It is imperative that the correct adjustment be maintained. Only through correct adjustment can a smooth and level finish be achieved in field working.

Loose chains lead to :

- Uneven performance across the width of the machine
- Uneven weed control
- Unsatisfactory incorporation
- Ineffective levelling
- Accelerated or premature chain wear
- Chains failing to engage with transport locators when folded
- Machine damage when folding or unfolding
- Uneven field surface with ridges and furrows being created. The leading 1/3rd of a loose chain is much more aggressive than the trailing 1/3rd and the center. This will mean that middle of the machine's front pair of chains will aggressively move soil outwards. The machine's rear pair of chains, if loose, have their aggressive 1/3rd near the wing extremity. It follows then that as the front discs push soil outwards, the least aggressive portion of the rear chain follows them and does not balance the soil movement. This is exacerbated at the wings, effectively creating a broad ridge about halfway out each wing. It won't be evident in one pass, but is possible if care is not taken over time.

**A correctly adjusted machine will not cause this phenomenon.**



## Settings for correct working height

To adjust the swivel height at the wings, relocate one of the polyurethane spacers either above or below the fixed mounting tube.

### Adjustment

|   |   |
|---|---|
| 1 | Loosen chain tension completely   |
| 2 | Undo 2 x M10 bolts from corresponding spacer set and take the two halves off of the drop leg tube |
| 3 | Replace it in the selected position after raising or lowering the drop leg                        |
| 4 | Reinstall the M10 bolts and re-tension the chain  |

It is possible to install all spacers either above or below the mounting tube giving a maximum of 4" (100mm) of adjustment.

