

# 46

Kelly 

## Tillage System Model 46 Assembly Manual

Revision D - May 2018

Serial Number:



Kelly Engineering  
PO Box 100  
Booloroo Centre  
South Australia 5482  
P +61 8 8667 2253  
F +61 8 8667 2250  
W [kellyengineering.com.au](http://kellyengineering.com.au)

# Thank you for choosing a Kelly Engineering product

We trust that you find the following manual clear and easy to follow. If you should require additional customer support or assistance, please do not hesitate to contact us.

Spare parts can be purchased, as required, through your local dealer or by contacting Kelly Engineering Australia or in the United States, Hood & Company.

Kelly Engineering welcomes feedback. Should you have any difficulties that you wish to raise, suggestions for improvement or modifications that you feel would enhance our products we look forward to hearing from you.

## **Australia**

### **Kelly Engineering**

**PO Box 100**

**Boomeroo Centre SA 5482**

**Phone:** + 61 8 8667 2253

**Fax:** + 61 8 8667 2250

**Email:** [sales@kellyengineering.com.au](mailto:sales@kellyengineering.com.au)

**Spare Parts:** [parts@kellyengineering.com.au](mailto:parts@kellyengineering.com.au)

**Website:** [www.kellyengineering.com.au](http://www.kellyengineering.com.au)

## **United States**

### **Kelly Engineering**

**Website:** [www.kellyharrows.com](http://www.kellyharrows.com)

## **Spare Parts**

### **Hood & Company Inc**

**Springfield MO**

**Phone:** 417 865 2100

**Fax:** 417 865 2105

**Email:** [hoodco@hoodco.com](mailto:hoodco@hoodco.com)

# Contents

	Page no
<b>Section 1: Unpacking</b>	<b>6</b>
<b>Section 2: Parts and Assembly</b>	<b>8</b>
<b>Section 3: Hydraulics Setup</b>	<b>86</b>
<b>Section 4: Light Kit</b>	<b>113</b>
<b>Section 5: Diagrams &amp; Charts</b>	<b>125</b>
<b>Section 6: Operation &amp; Assembly Updates</b>	<b>130</b>



This symbol indicates which bag the relevant fasteners are in



This symbol indicates which bag the relevant hydraulics are in

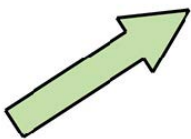

This symbol indicates which way the machine is travelling

This document highlights the part numbers and locations of U-bolts to suit machines constructed of imperial sized steel tube.

**Note: New machines will be supplied with the specific imperial sized U-bolt. Please use the specific imperial sized part number when ordering U-bolts as a spare part.**

0271-12105104	0271-12107106U	U-Bolt M12 x 107 Deep x 106 Wide
0271-128077	0271-1287279U	U-Bolt M12 x 82 Deep x 76 Wide
0271-16112104	0271-16114106U	U-Bolt M16 x 114 Deep x 106 Wide
0271-16160127	0271-16162129U	U-Bolt M16 x 162 Deep x 129 Wide
0271-1616077	0271-1616779U	U-Bolt M16 x 190 Deep x 106 Wide
0271-16185104	0271-16190106U	U-Bolt M16 x 190 Deep x 106 Wide
0271-168577	0271-168779U	U-Bolt M16 x 87 Deep x 79 Wide

## Bolt Torque Settings

Bolt Type	Wheel nut				U Bolt			Grade 8.8 Bolt					Grade 10.9 Bolt		Grade 8 Bolt
	M18	M20	1/2"	9/16"	M10	M12	M16	M10	M12	M16	M20	M24	M20	M24	1" UNF
<b>Ft lb</b>	255	265	90	100	22	36	55	32	48	140	190	270	300	350	849
<b>Nm</b>	345	360	125	140	30	50	75	44	65	190	260	370	406	475	1151

[1] When fitting a wheel & tire to a hub, tighten the wheel nuts in rotation to the correct tension. To achieve this choose a wheel nut & tighten, then proceed clockwise to the next wheel nut & tighten & so on until all wheel nuts are tight. Then repeat the procedure to check that all nuts are tight. Do not use impact tools to tighten wheel nuts. For a guide to the correct tension of the wheel nuts please use the appropriate tension for your size wheel nuts from the Bolt Torque Settings table.

Torque values are for dry threads and surfaces however it is permissible to apply a small amount of anti corrosive oil to the threads.

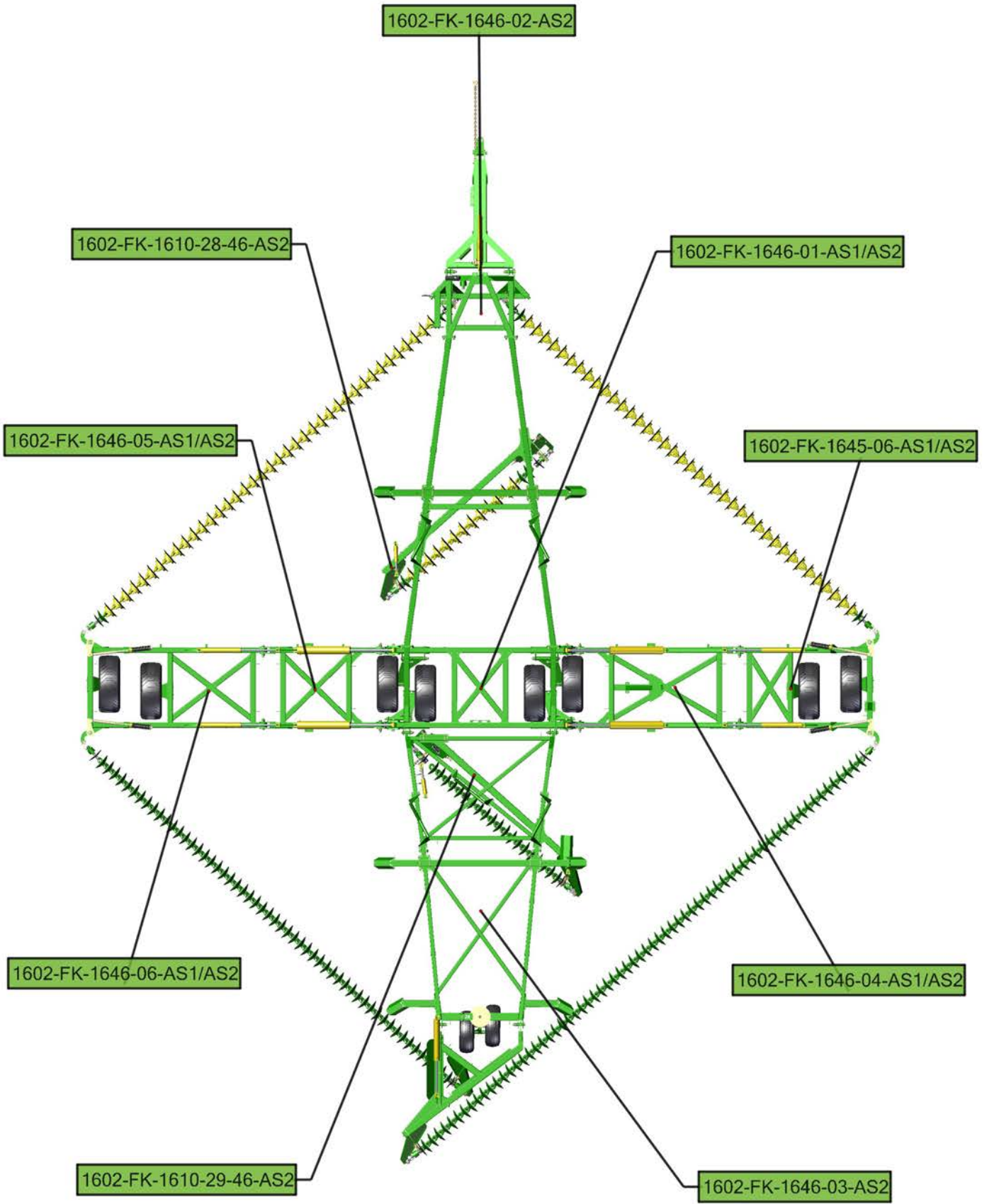

# Section 1

## Unpacking



### **CAUTION**

Before cutting straps attach slings or chains and take the weight of the frames to avoid them slipping or falling and causing injury.



### **CAUTION**

Wear eye and hand protection when cutting straps. Sharp edges are exposed as straps separate and may cause injury.



### **CAUTION**

To avoid falling or moving components, before cutting straps attach slings or chains to individual pieces and only cut the straps holding the piece to be lifted.

- Remove boxes from rear of container one at a time using a forklift truck. Each box weighs approximately 2600 lbs (1200 kg)
- Cut straps holding bundles and separate parts and place in assembly area
- Identify parts for each machine by serial no. or description and separate. Open parts box and check that all parts are accounted for against checklist
- Once all parts have been identified machines are ready for assembly
- Read assembly instructions before proceeding.

# Section 2

Parts & Assembly



Please note -  
Start at page 22 for machines that are  
part assembled on delivery

Item No.	Description	Qty	Number
1	46' Centre Frame	1	1646-01
2	LH Walking Axle Arm	2	1610-30
3	RH Walking Axle Arm	2	1610-31
4	1-1/2 ID x 2" DU Bush	8	0113-MB 24DU32

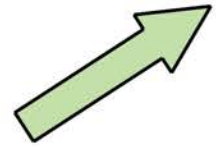

Please note bushes are factory inserted

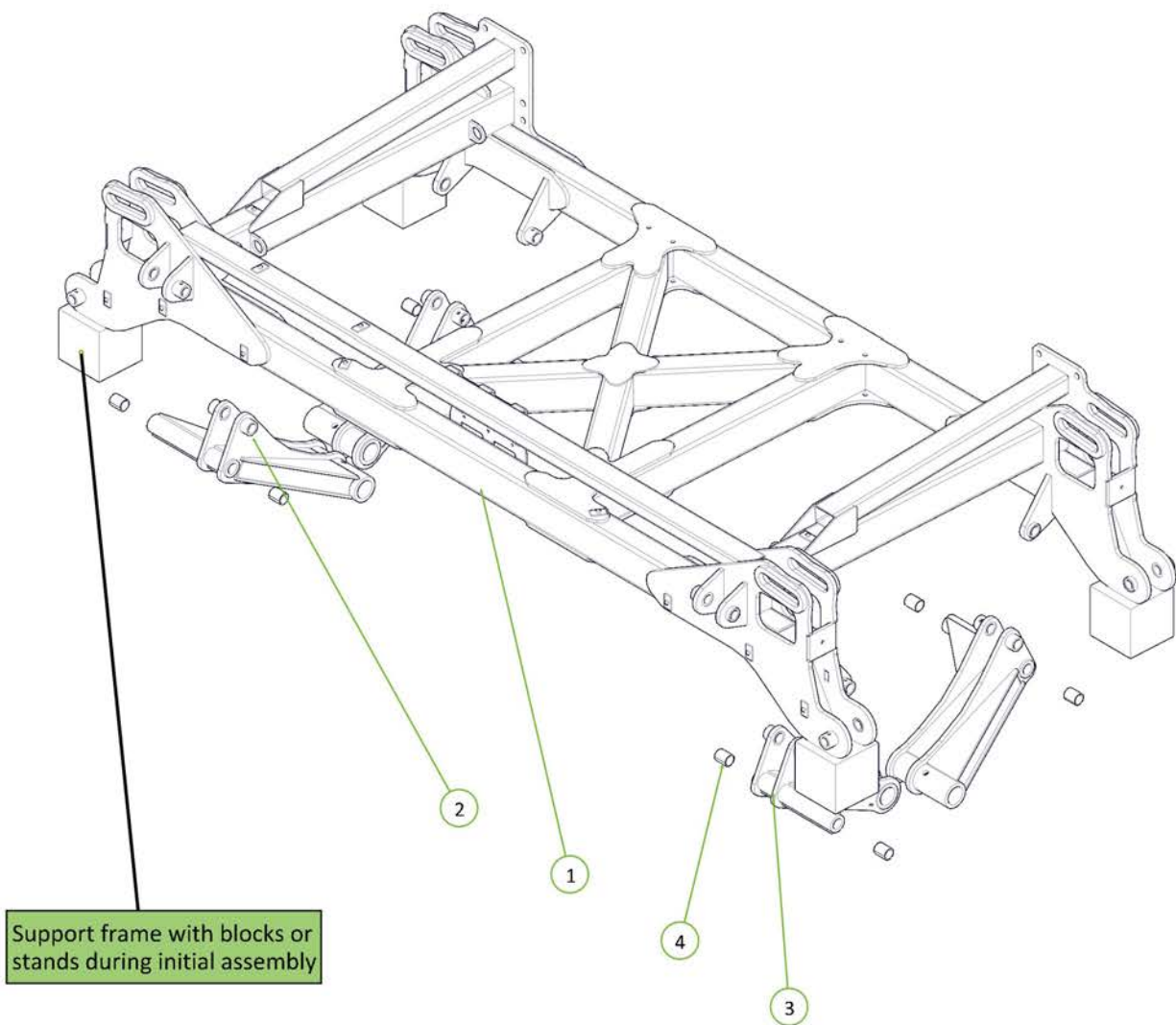

Item No.	Description	Qty	Number
1	Cotter Pin M13 x 63	4	0261-PINC1363
2	Walking Axle Pivot Pin	4	1601-P38-525
3	Nyloc Nut M12	4	0221-NYL12
4	M12 x 65 grade 8.8 ZP Bolt	4	0211-1265
5	Washer High Tensile 1 3/8"	8	0232-HT11-2

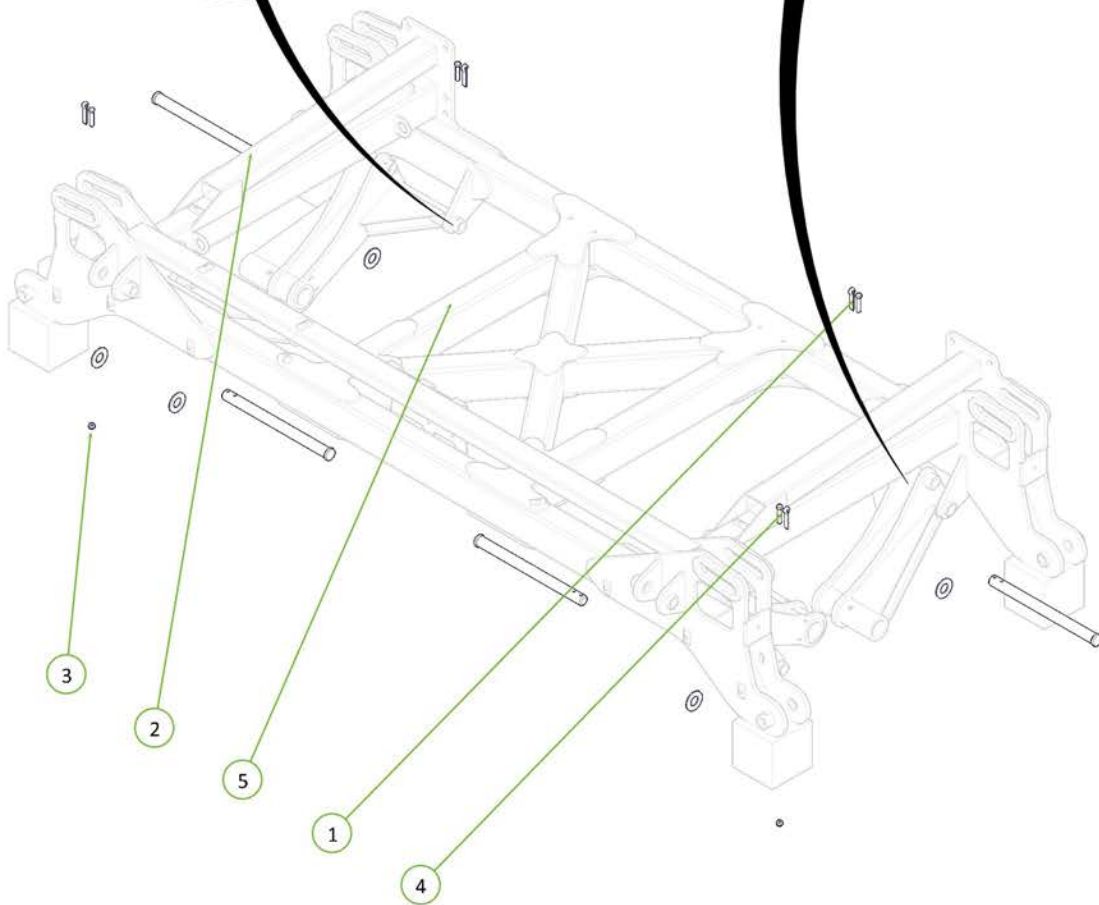
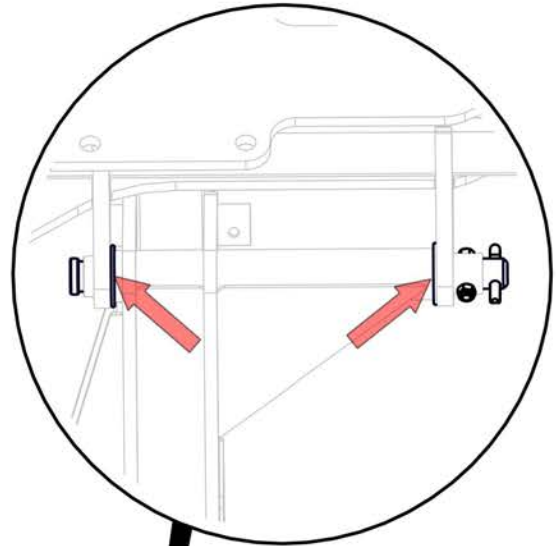
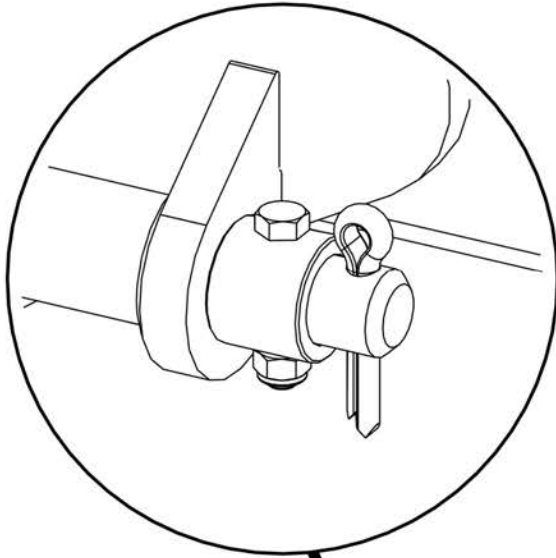
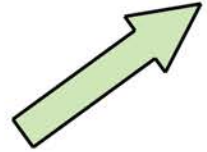

Item No.	Description	Qty	Number
1	Walking Axle Linkage	2	1610-33
2	1-1/2 ID x 1-1/4mm DU Bush	8	0113-MB 24DU20
3	Walking Axle Linkage Pivot Pin	4	1601-P38-220
4	Cotter Pin M13 x 63	4	0261-PINC1363
5	M12 x 65 grade 8.8 ZP Bolt	4	0211-1265
6	Nyloc Nut M12	4	0221-NYL12

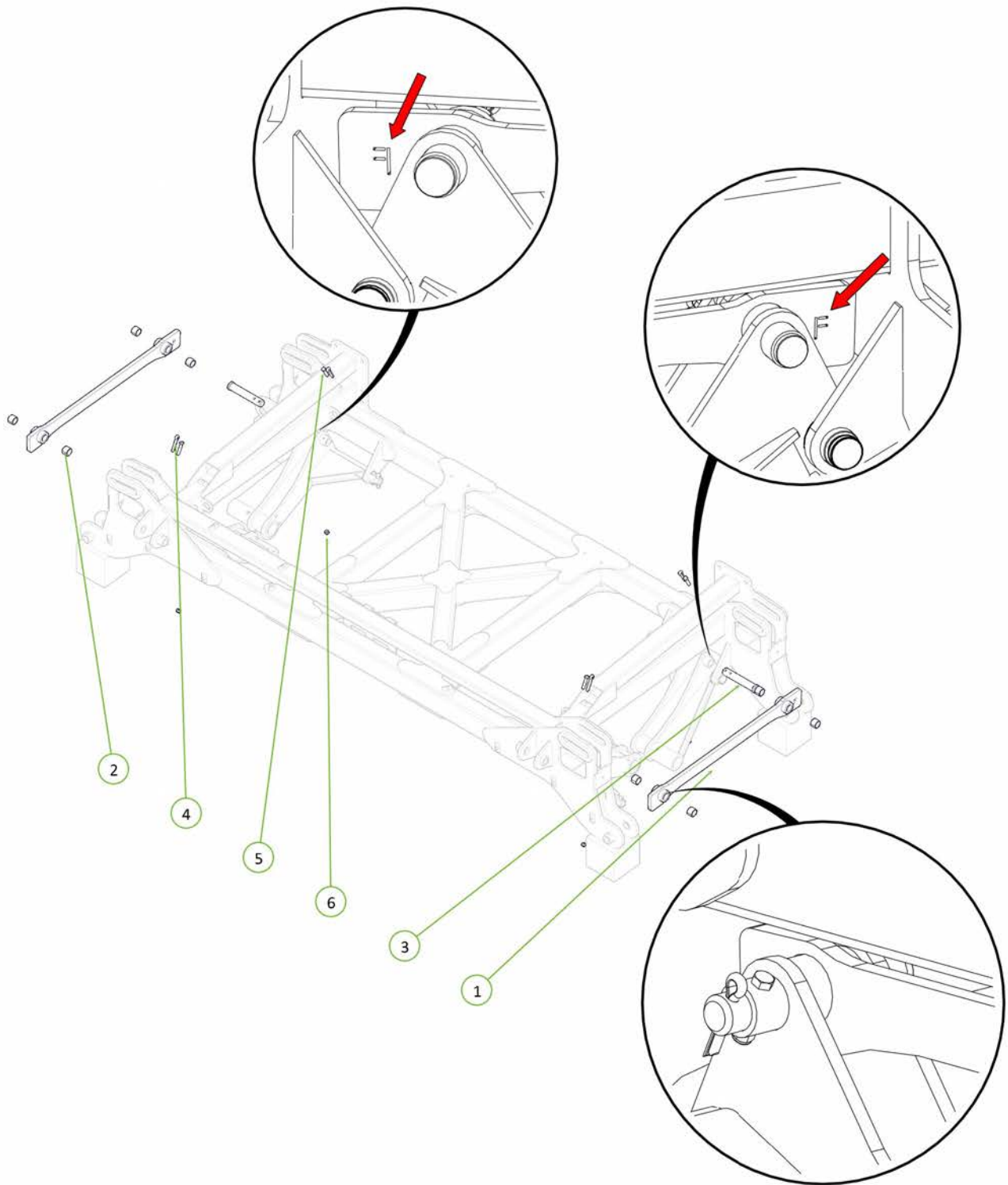

Item No.	Description	Qty	Number
1	2.75"R C/W 6 tonne 8 on 8" PCD Complete Assembly	4	0733-SH27596880
2	M20 x 120 grade 8.8 ZP Bolt	4	0211-20120
3	Nyloc Nut M20	4	0221-NYL20

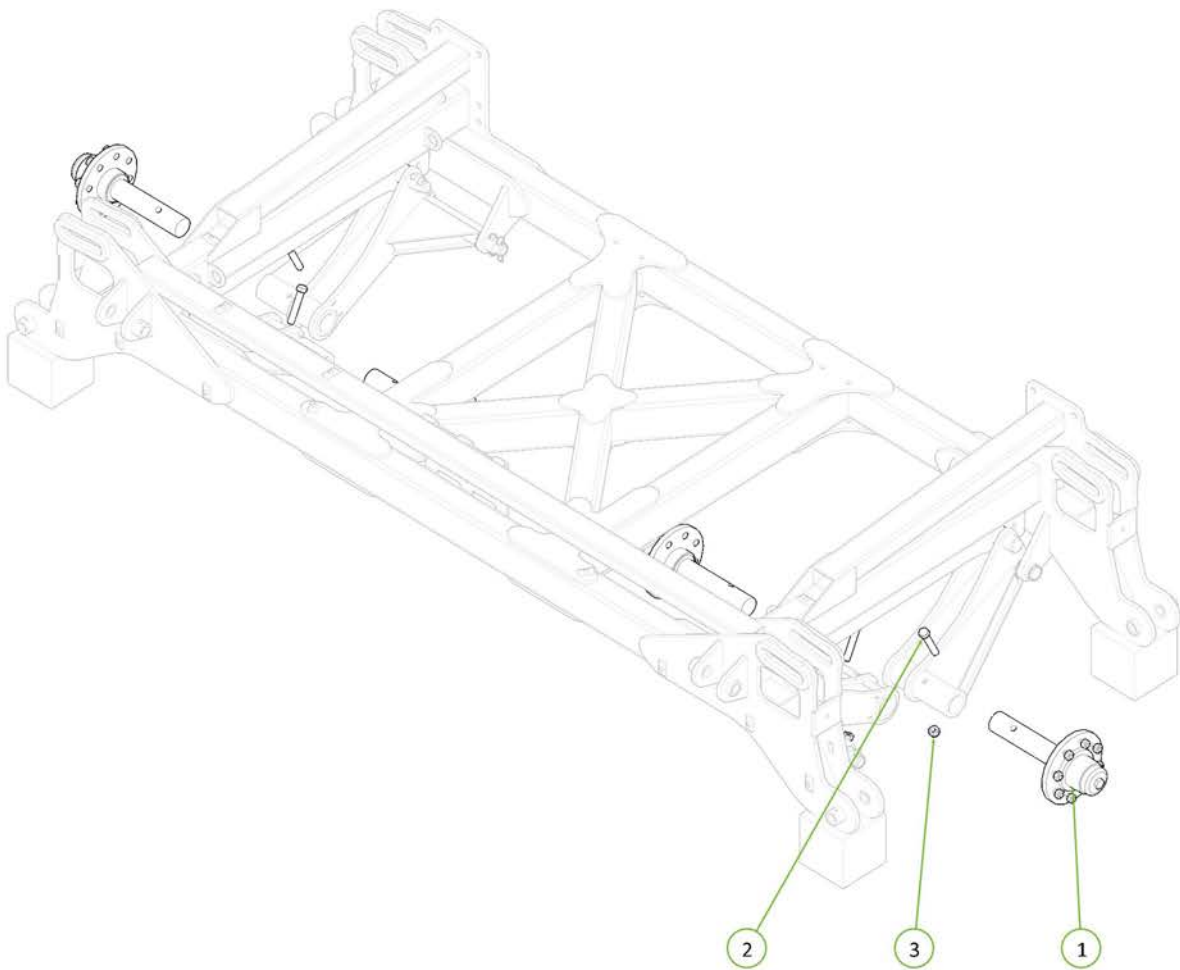
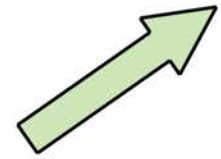

Item No.	Description	Qty	Number
1	Wing Folding Buffer	4	1201-12
2	M16 x 55 grade 8.8 zp Bolt	4	0211-1655
3	Washer Flat M16	4	0231-F16
8	Nyloc Nut M16	4	0221-NYL16

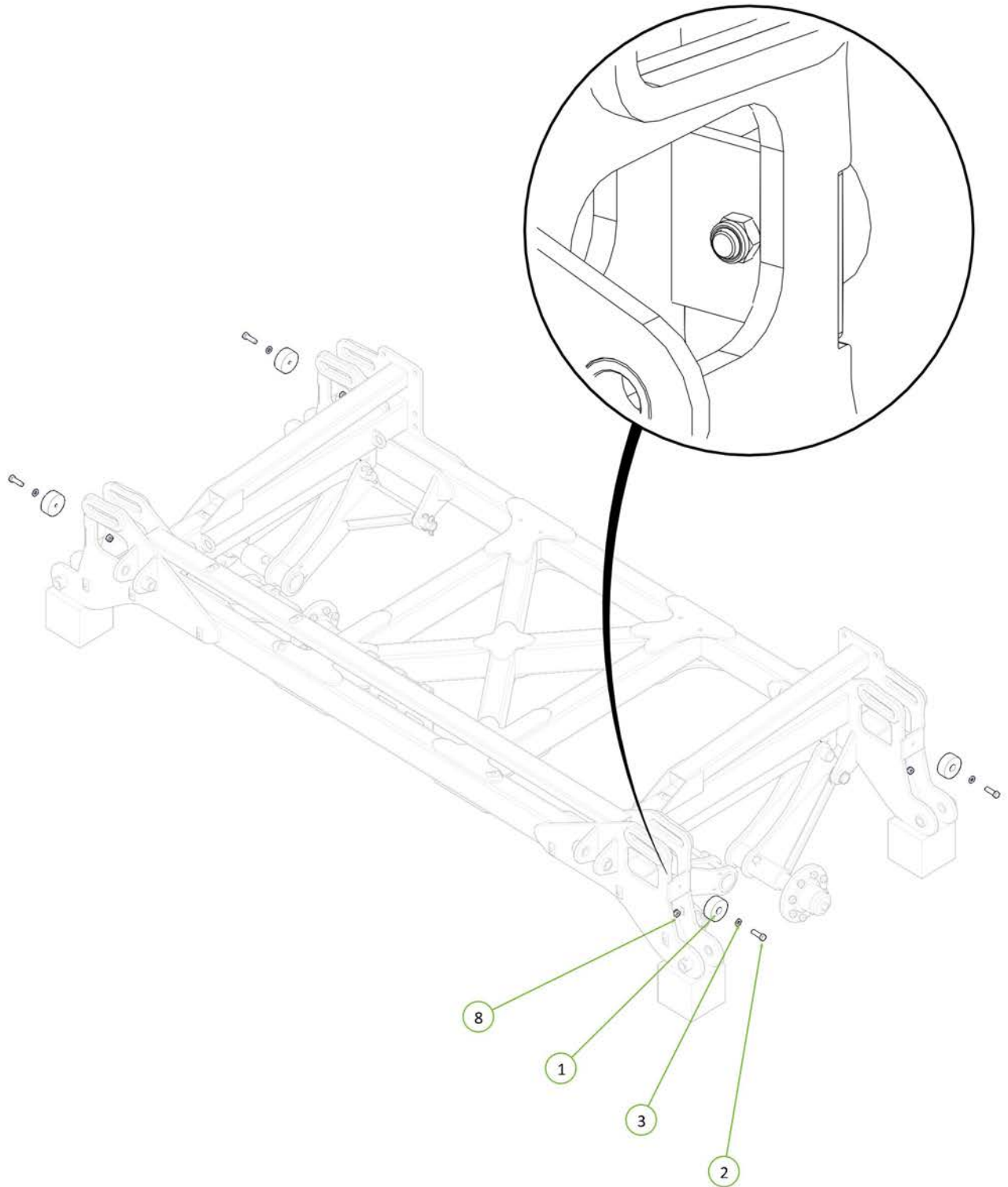
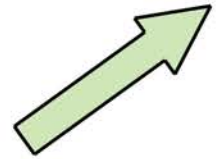

Item No.	Description	Qty	Number
1	46' RH Inner Wing Frame	1	1646-04
2	35 ID x 30mm DU Bush	4	0113-MB 3530DU
3	PCH Wing Pivot Pin	2	0801-10-08-235
4	COTTER PIN M13 X 63mm	2	0261-PINC1363
5	M12 x 65 grade 8.8 ZP Bolt	2	0211-1265
6	Nyloc Nut M12	2	0221-NYL12

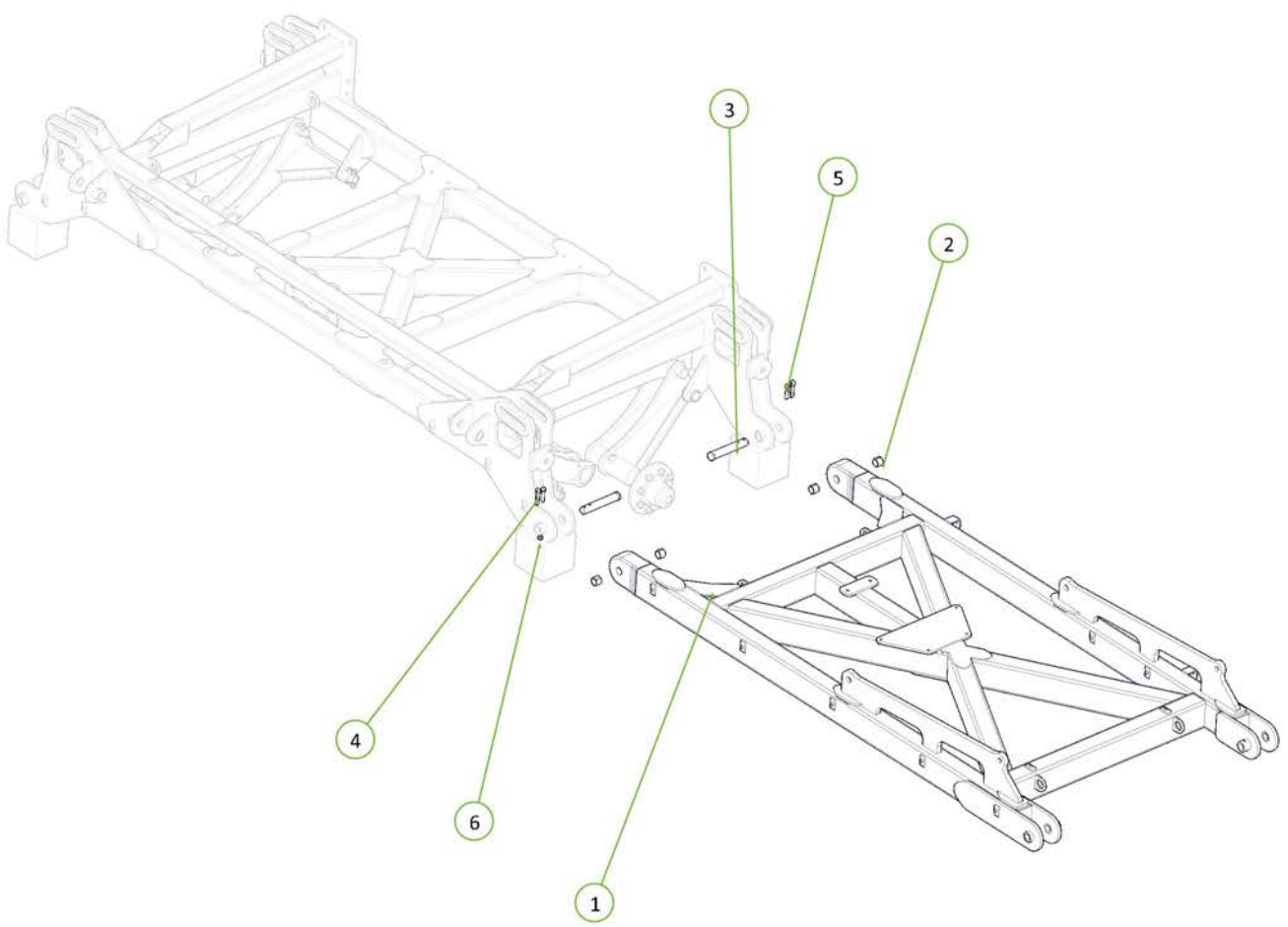
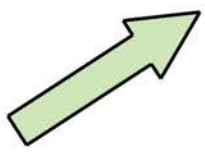

Item No.	Description	Qty	Number
1	46' RH Outer Wing Frame	1	1646-06
2	35 ID x 30mm DU Bush	4	0113-MB 3530DU
3	PCH Wing Pivot Pin	2	0801-10-08-235
4	COTTER PIN M13 X 63mm	2	0261-PINC1363
5	Nyloc Nut M12	2	0221-NYL12
6	M12 x 65 grade 8.8 ZP Bolt	2	0211-1265

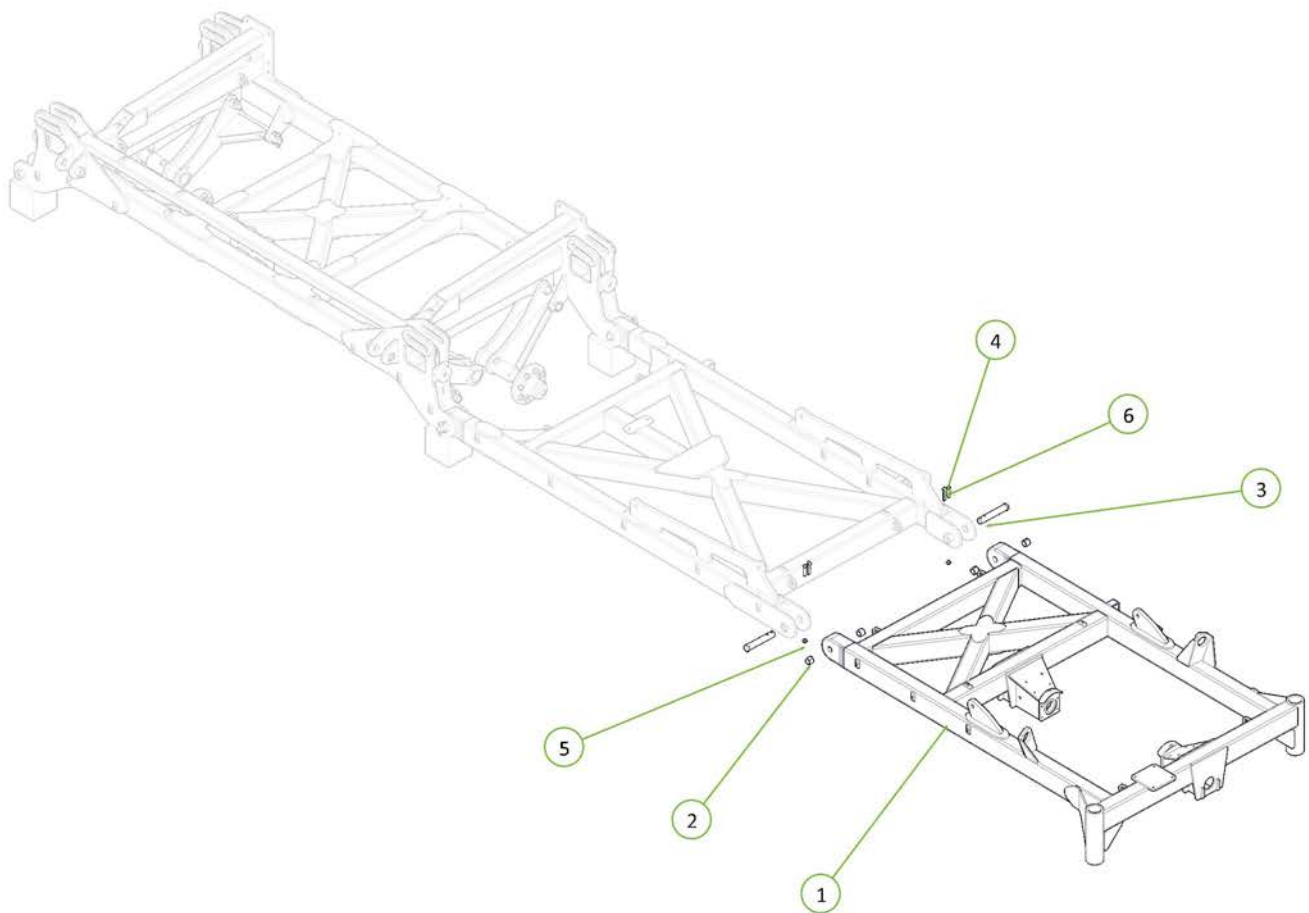



Item No.	Description	Qty	Number
1	2.75"R C/W 6 tonne 8 on 8" PCD Complete Assembly	2	0733-SH27596880
2	M20 x 170 grade 8.8 ZP Bolt	2	0211-20170
3	Nyloc Nut M20	2	0221-NYL20

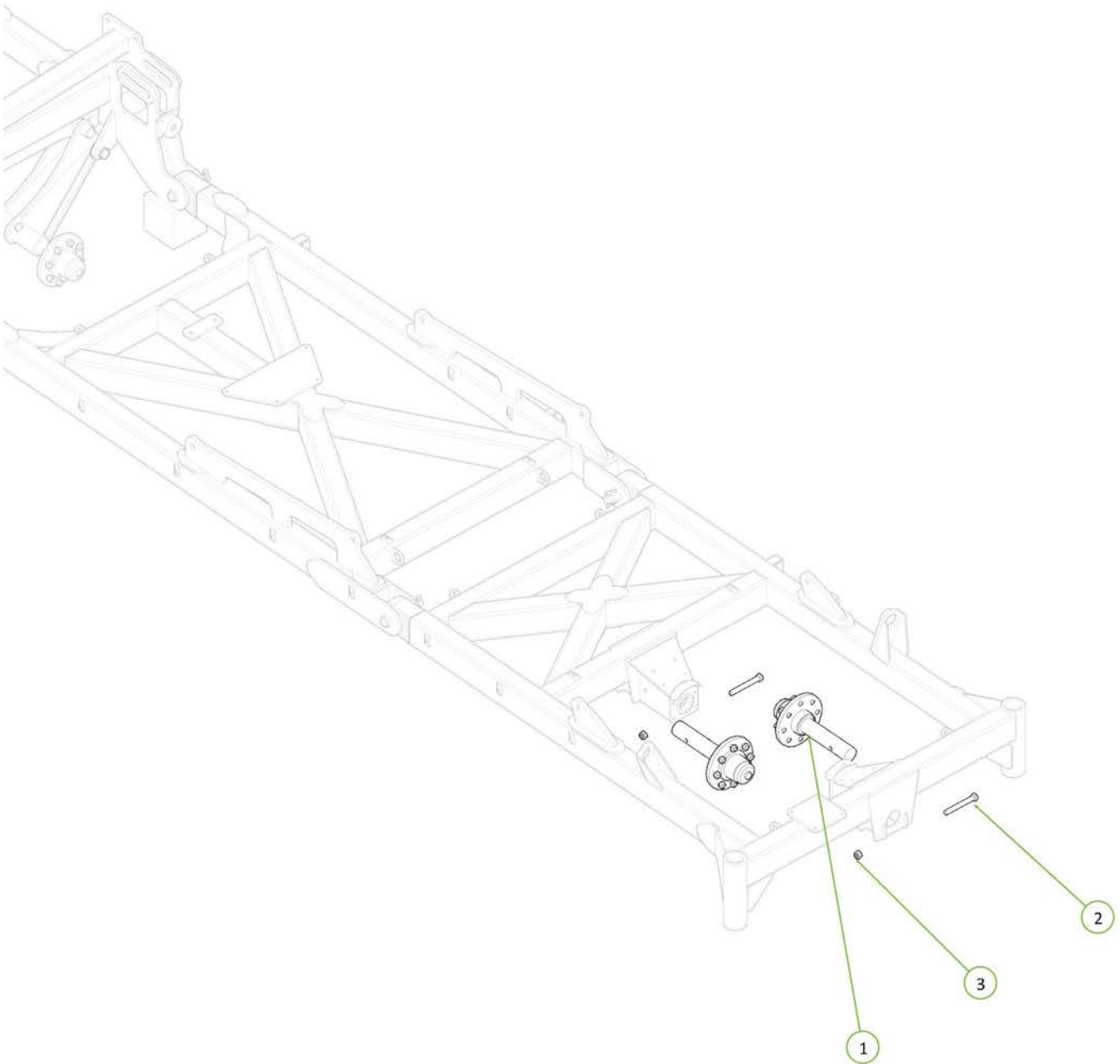
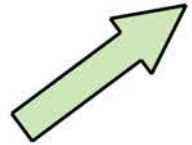

Item No.	Description	Qty	Number
1	46' LH Inner Wing Frame	1	1646-05
2	Cotter Pin M13 x 63	2	0261-PINC1363
3	35 ID x 30mm DU Bush	4	0113-MB 3530DU
4	PCH Wing Pivot Pin	2	0801-10-08-235
5	Nyloc Nut M12	2	0221-NYL12
6	M12 x 65 grade 8.8 ZP Bolt	2	0211-1265

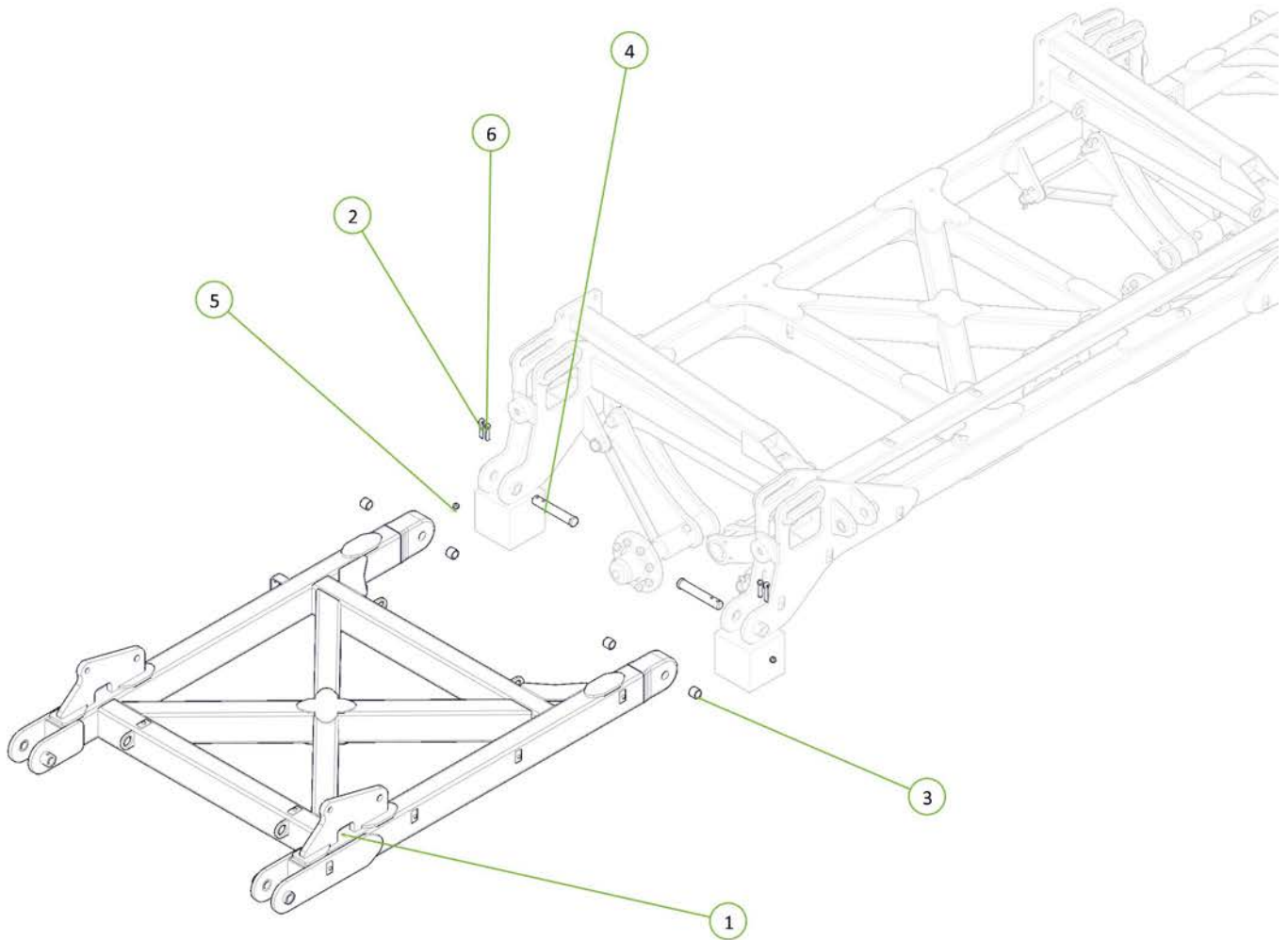

Item No.	Description	Qty	Number
1	46' LH Outer Wing Frame	1	1646-07
2	35 ID x 30mm DU Bush	4	0113-MB 3530DU
3	PCH Wing Pivot Pin	2	0801-10-08-235
4	COTTER PIN M13 X 63mm	2	0261-PINC1363
5	M12 x 65 grade 8.8 ZP Bolt	2	0211-1265
6	Nyloc Nut M12	2	0221-NYL12

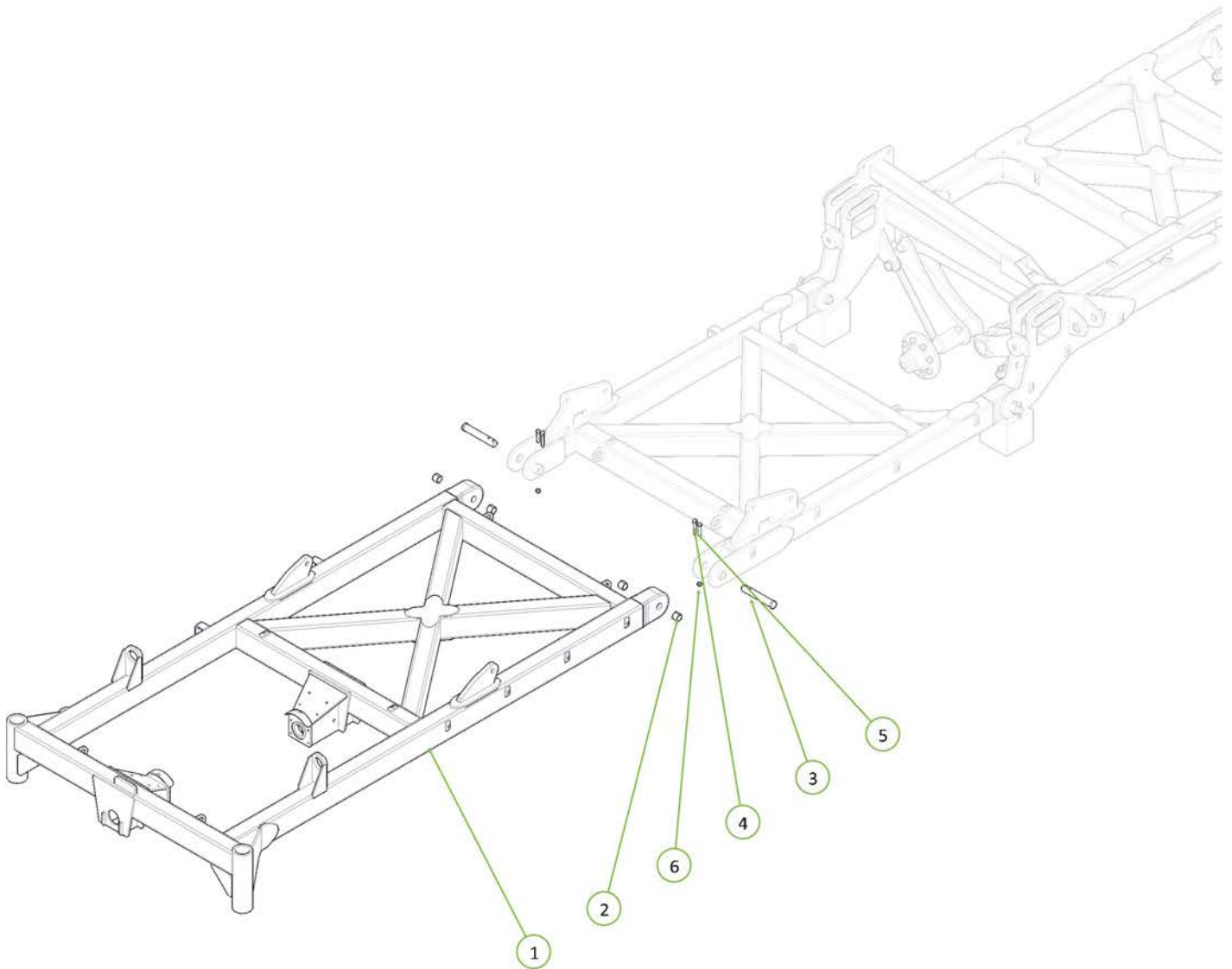

Item No.	Description	Qty	Number
1	2.75"R C/W 6 tonne 8 on 8" PCD Complete Assembly	2	0733-SH27596880
2	Nyloc Nut M20	2	0221-NYL20
3	M20 x 170 grade 8.8 ZP Bolt	2	0211-20170

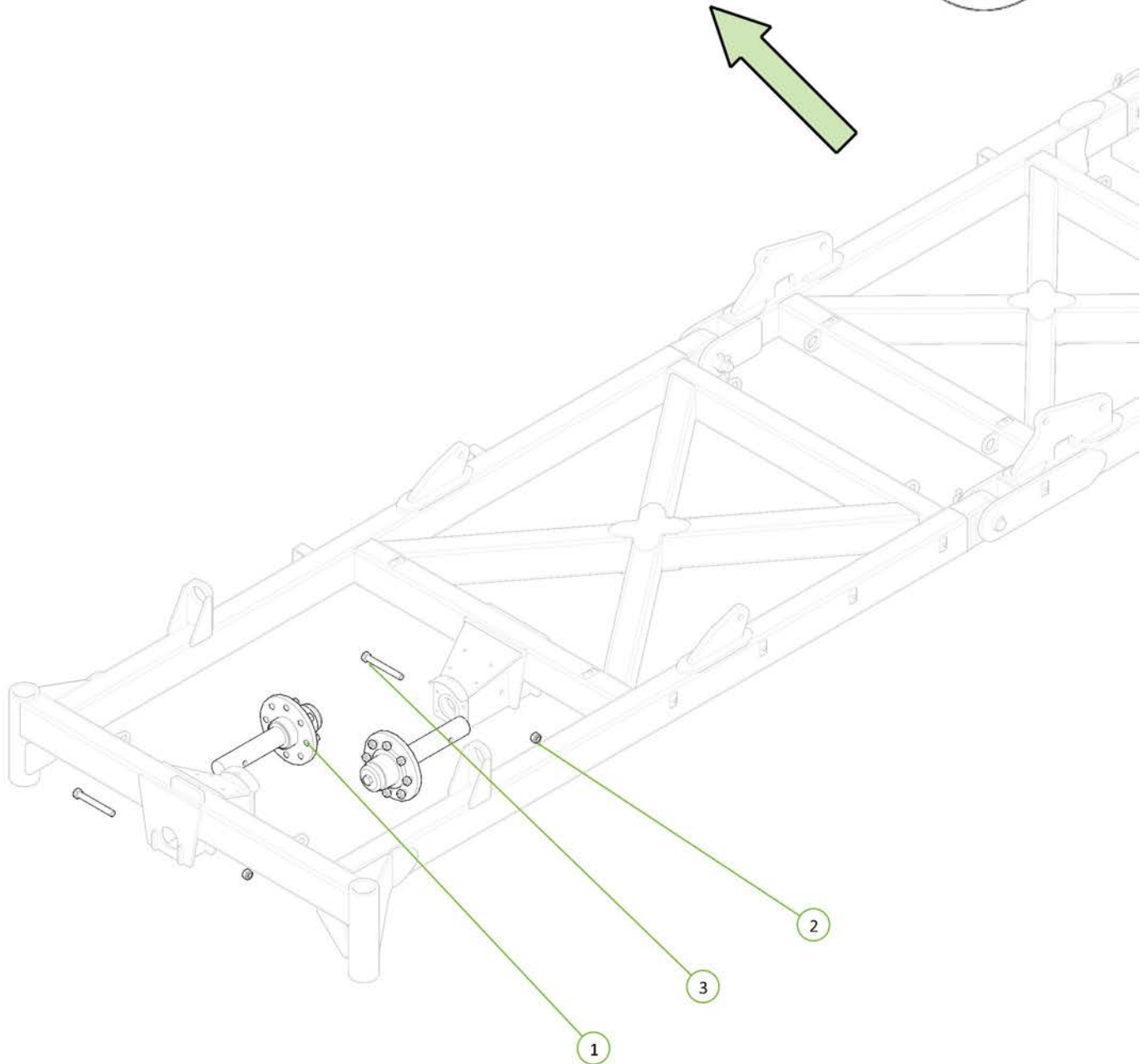

Item No.	Description	Qty	Number
1	5" Bore 30" Stroke 3 1/8" S/Tube 2" Rod Hydraulic Cylinder	4	0311-530STSP
2	Long Cylinder Pin Bearing Bush	8	1201-19

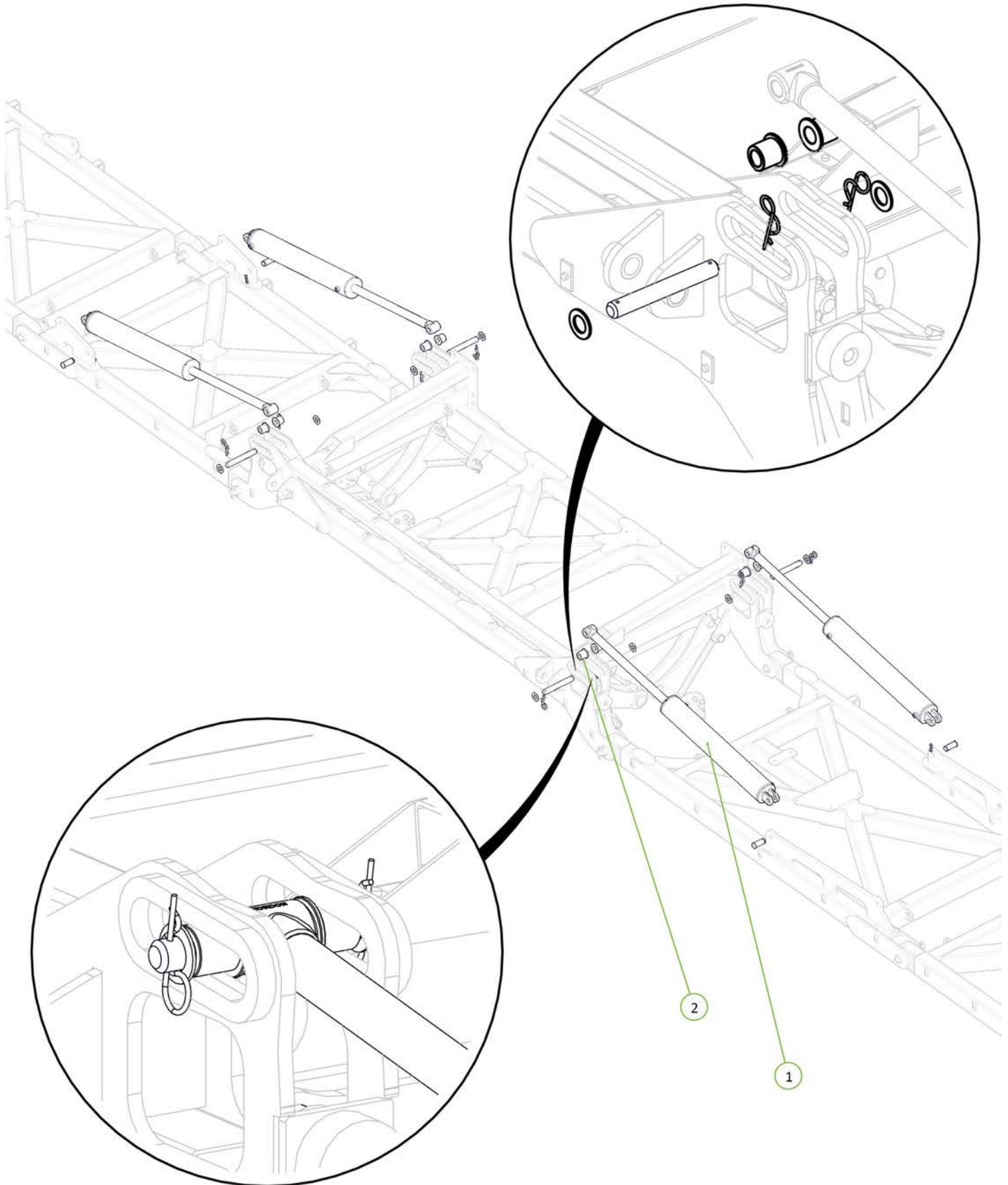
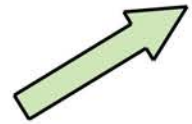

Item No.	Description	Qty	Number
1	3" Bore x 24" Stroke 1.5" Rod Cylinder Side Port	2	0311-324SP

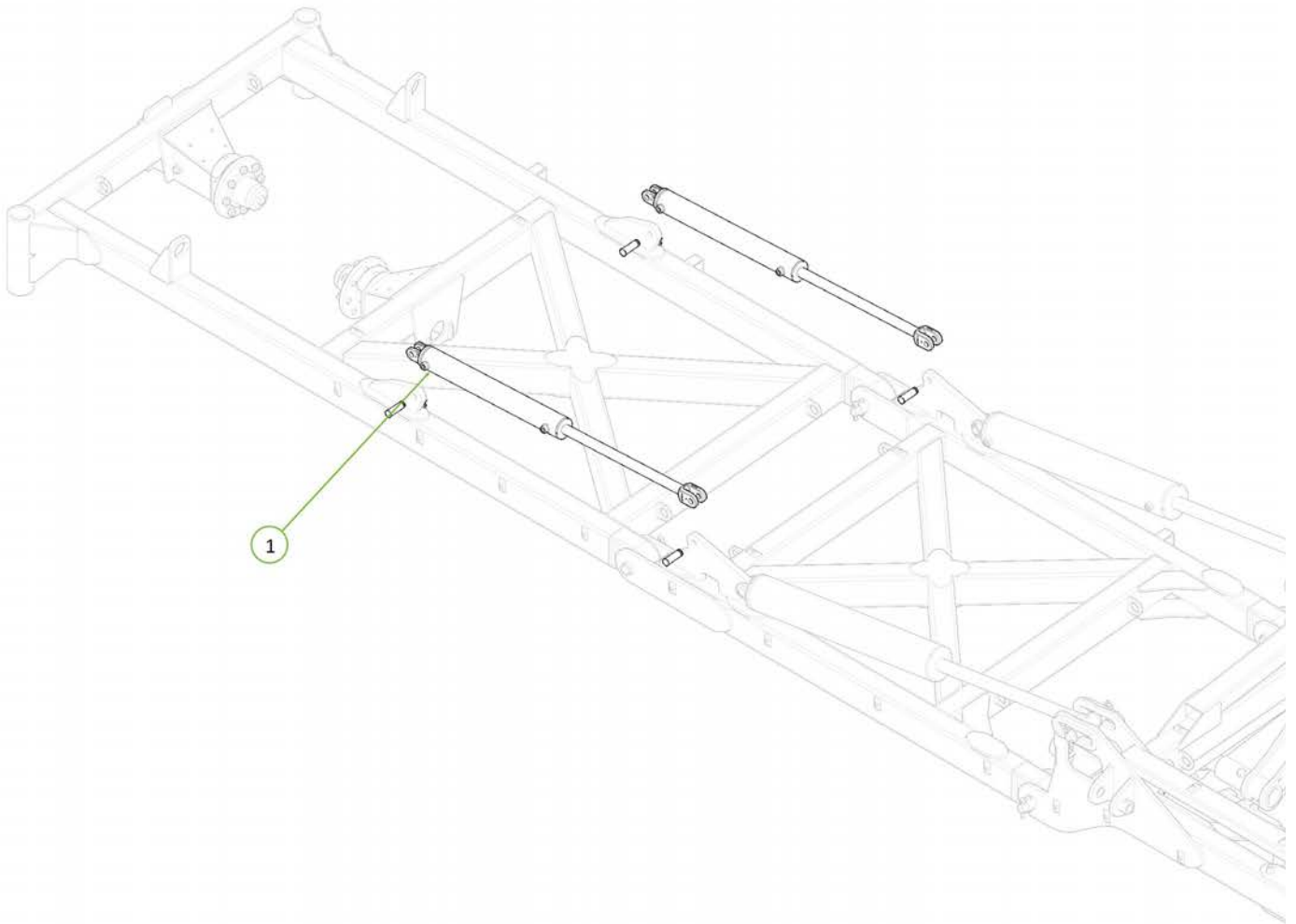
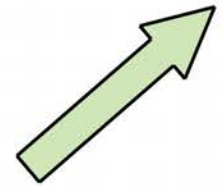

Item No.	Description	Qty	Number
1	3" Bore x 24" Stroke 1.5" Rod Cylinder Side Port	2	0311-324SP

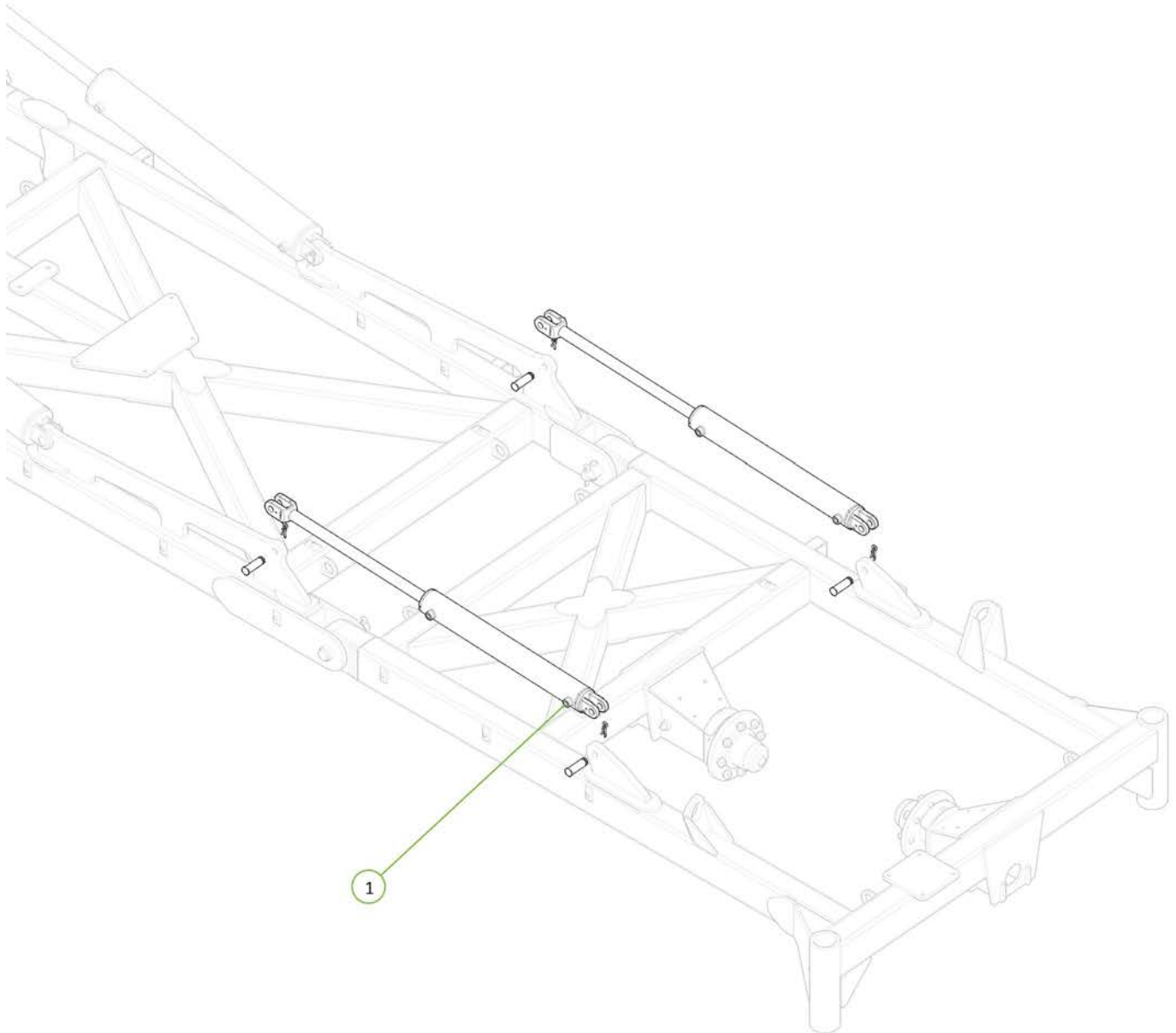
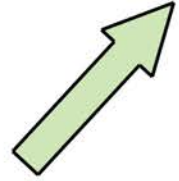

Item No.	Description	Qty	Number
1	46' Front A-Frame Front Section Frame	1	1646-02F
2	46' Front A-Frame Brace Section Frame	1	1646-02B
3	46' Front A-Frame LH Section Frame	1	1646-02L
4	46' Front A-Frame RH Section Frame	1	1646-02R
5	M24 x 75 grade 8.8 zp Bolt	20	0211-2475
6	Nyloc Nut M24	20	0221-NYL24
7	M16 x 55 grade 8.8 zp Bolt	16	0211-1655
8	Nyloc Nut M16	16	0221-NYL16

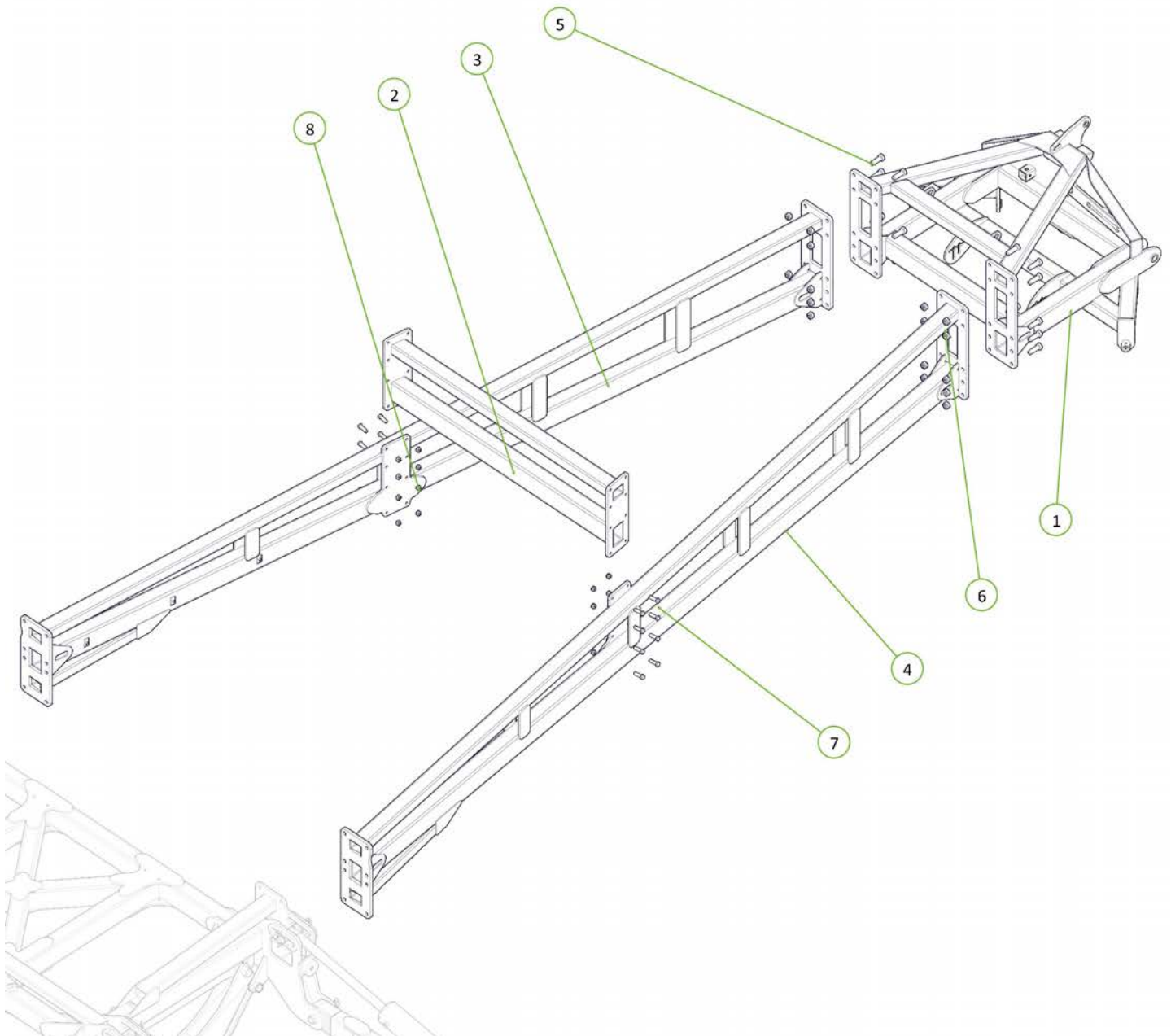
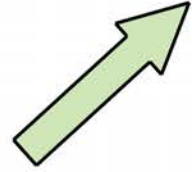



Item No.	Description	Qty	Number
1	Nyloc Nut M24	16	0221-NYL24
2	M24 x 65 grade 8.8 zp Bolt	16	0211-24

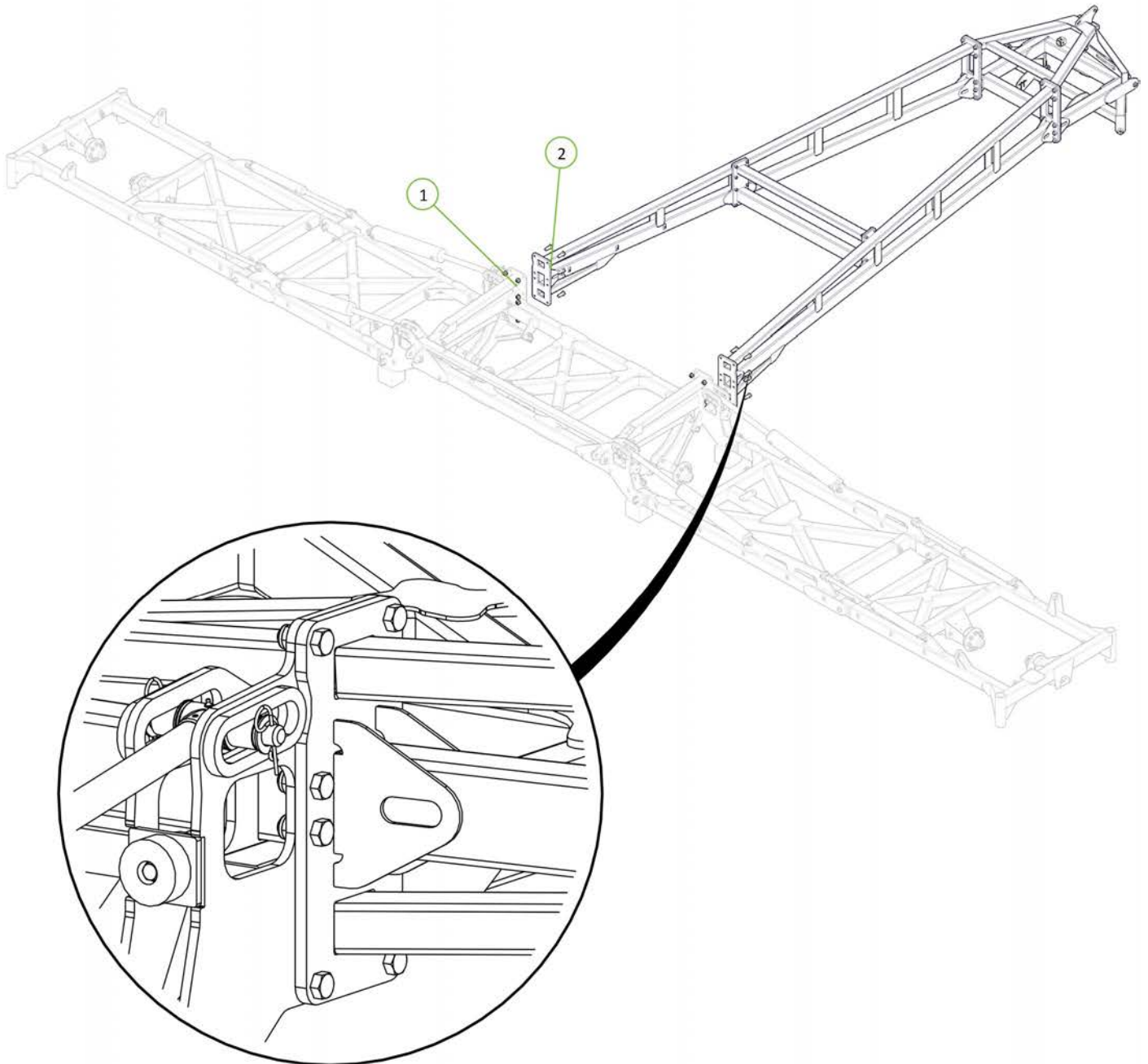
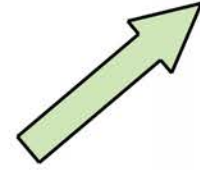

Item No.	Description	Qty	Number
1	400/60-22.5 Tyre on 8 on 8" PCD Rim	8	0751-400-60-22.5TR

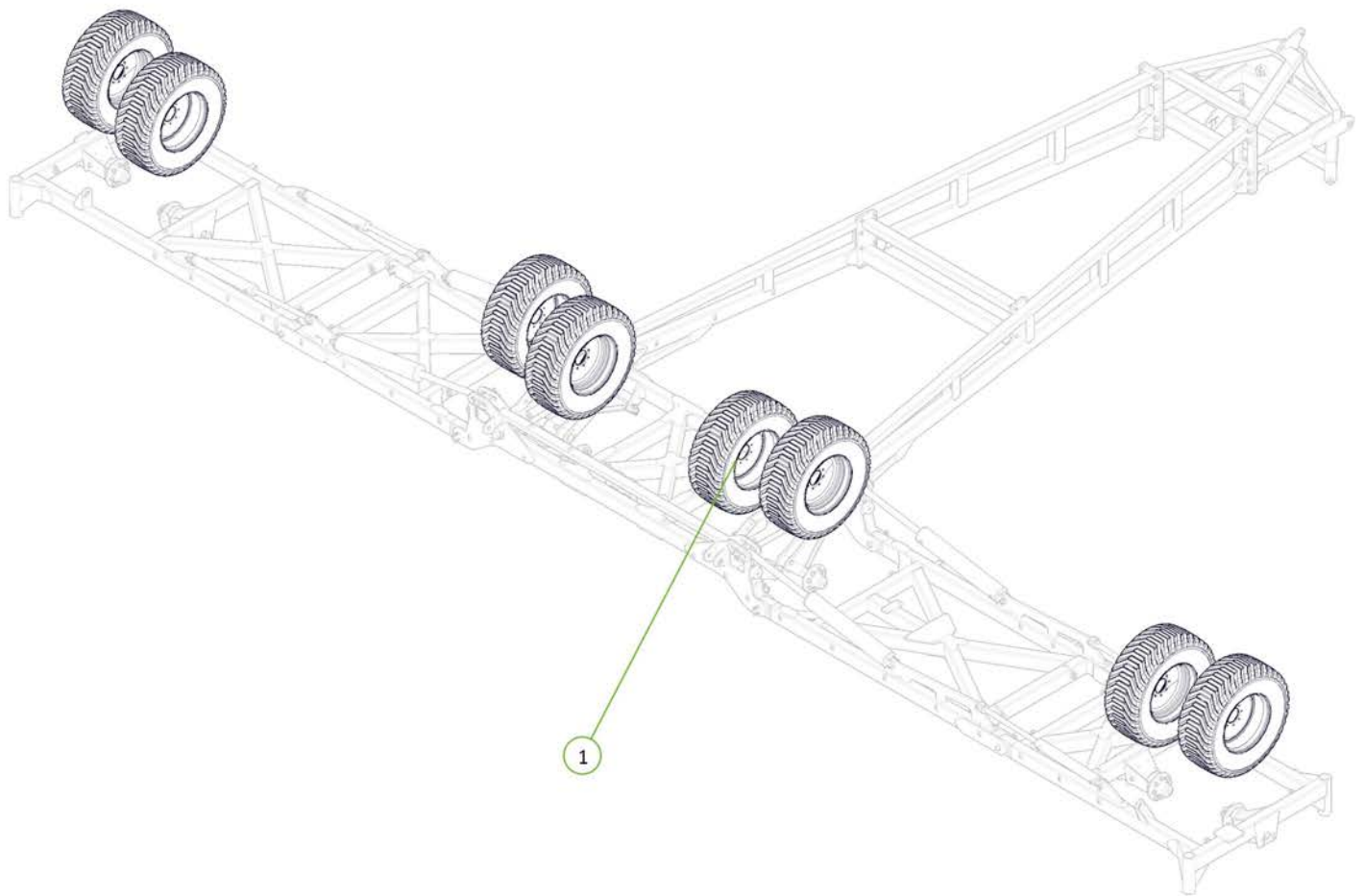
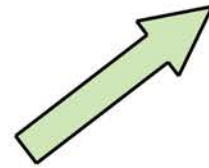

Item No.	Description	Qty	Number
1	Drawbar	1	1610-08
2	35 ID x 30mm DU Bush	4	0113-MB 3530DU
3	PCH Wing Pivot Pin	2	0801-10-08-235
4	Cotter Pin M13 x 63	2	0261-PINC1363
5	M12 x 65 grade 8.8 ZP Bolt	2	0211-1265
6	Nyloc Nut M12	2	0221-NYL12

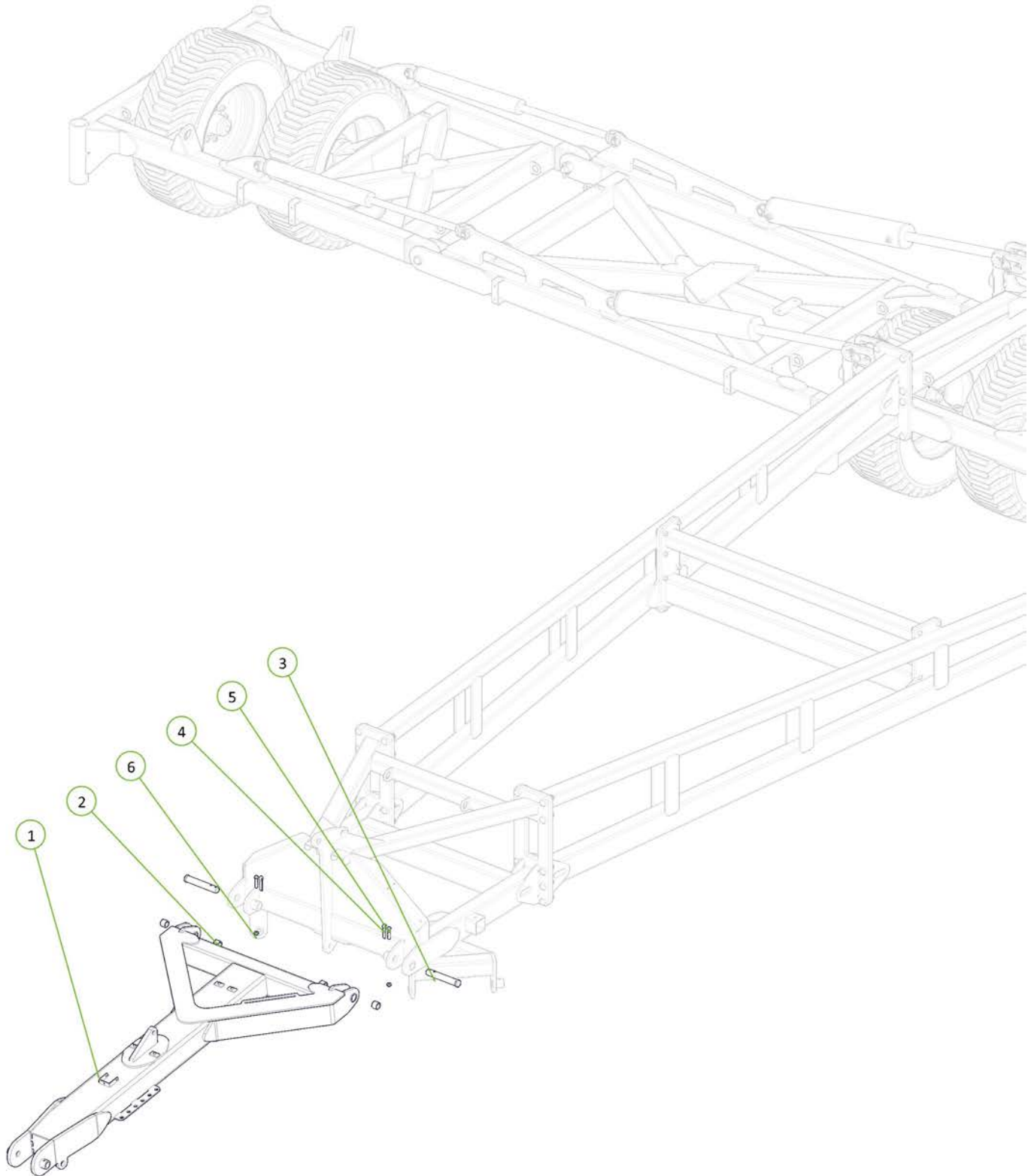
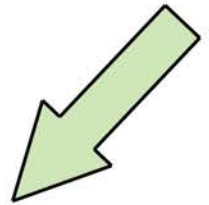

Item No.	Description	Qty	Number
1	Tow Hitch For Bull Pull Swivel Hitch	1	0810-09-BP
2	Swivel Hitch Assy CAT 5 (2-1/2" to 2-3/4" Pin)	1	0801-HITCHCAT5
3	Tow Hitch Pivot Pin	1	0801-10-06
4	1" UNF Grade 8 ZP Bolt	3	0213-1 51-2
5	Nyloc Nut 1" UNF	3	0223-NYL1
6	M12 x 65 grade 8.8 ZP Bolt	2	0211-1265
7	Nyloc Nut M12	2	0221-NYL12

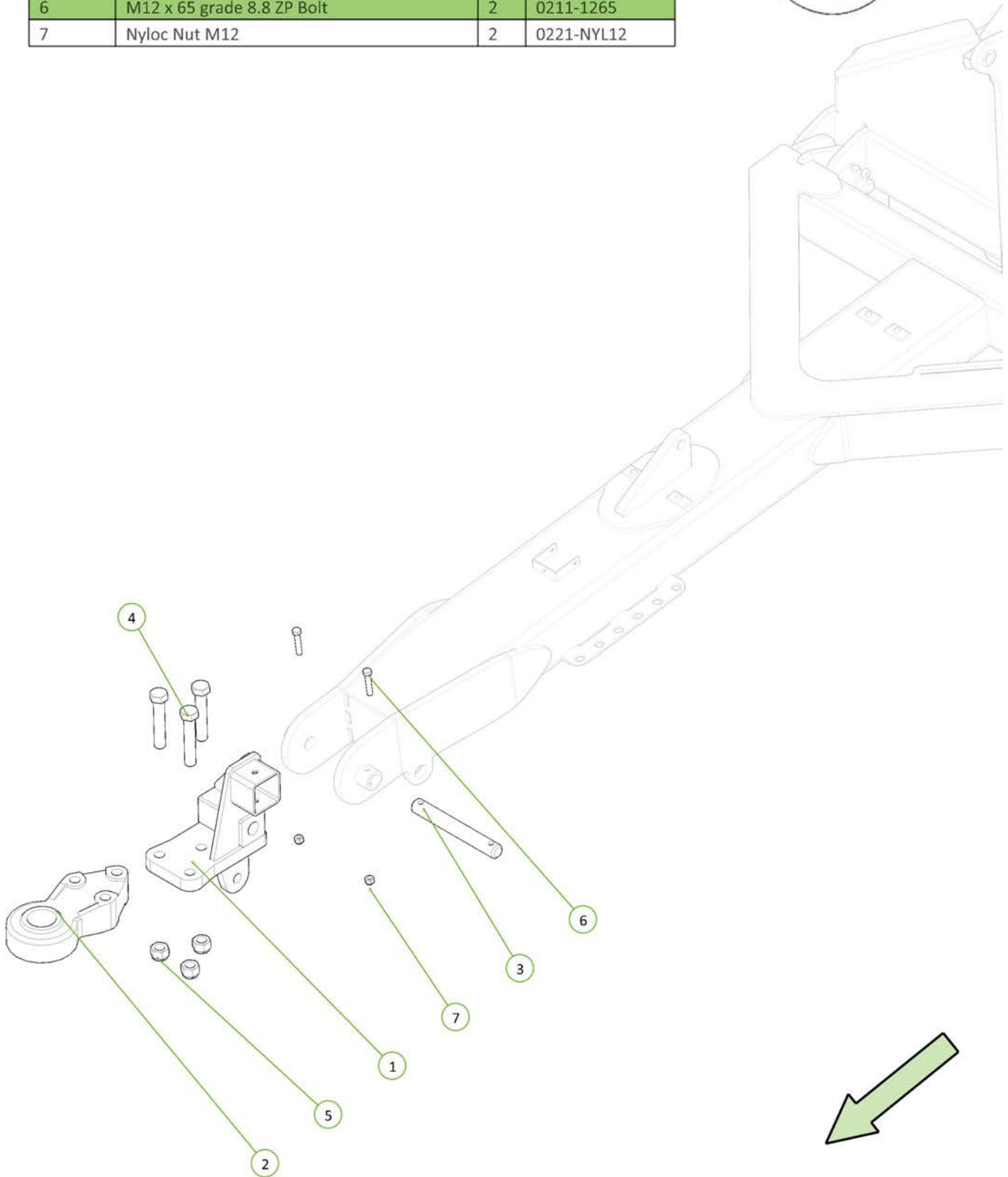

Item No.	Description	Qty	Number
1	Parallel Arm	1	1610-22
2	Clevis Pin 25mm x 75mm	2	0801-KE0307-1
3	Washer Flat M24	2	0231-F24
4	Cotter Pin M6 x 50mm	2	0261-PINC650

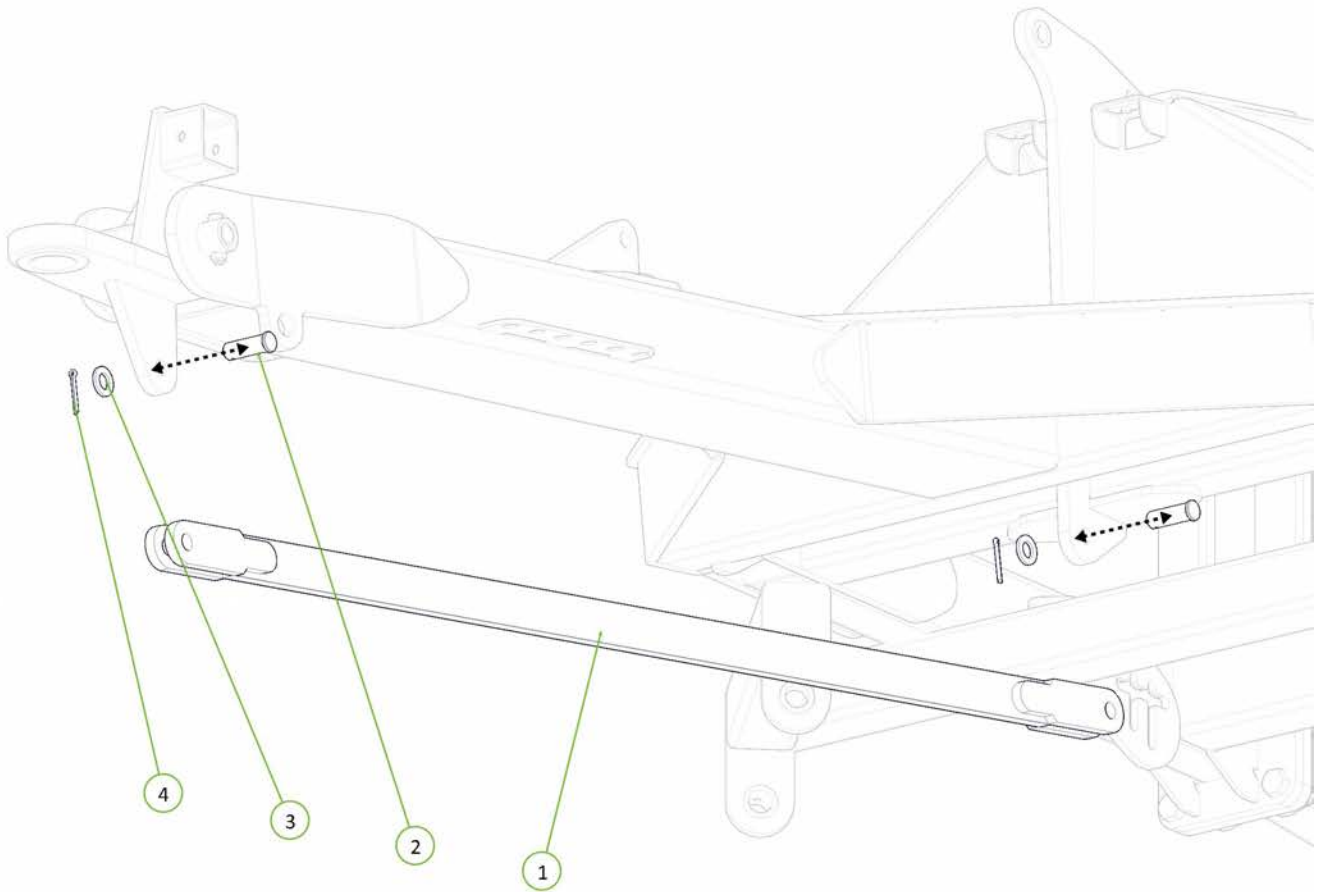

Item No.	Description	Qty	Number
1	4" Bore 12" Stroke 1.75" Rod Extended Hydraulic Cylinder	1	0311-412EXT

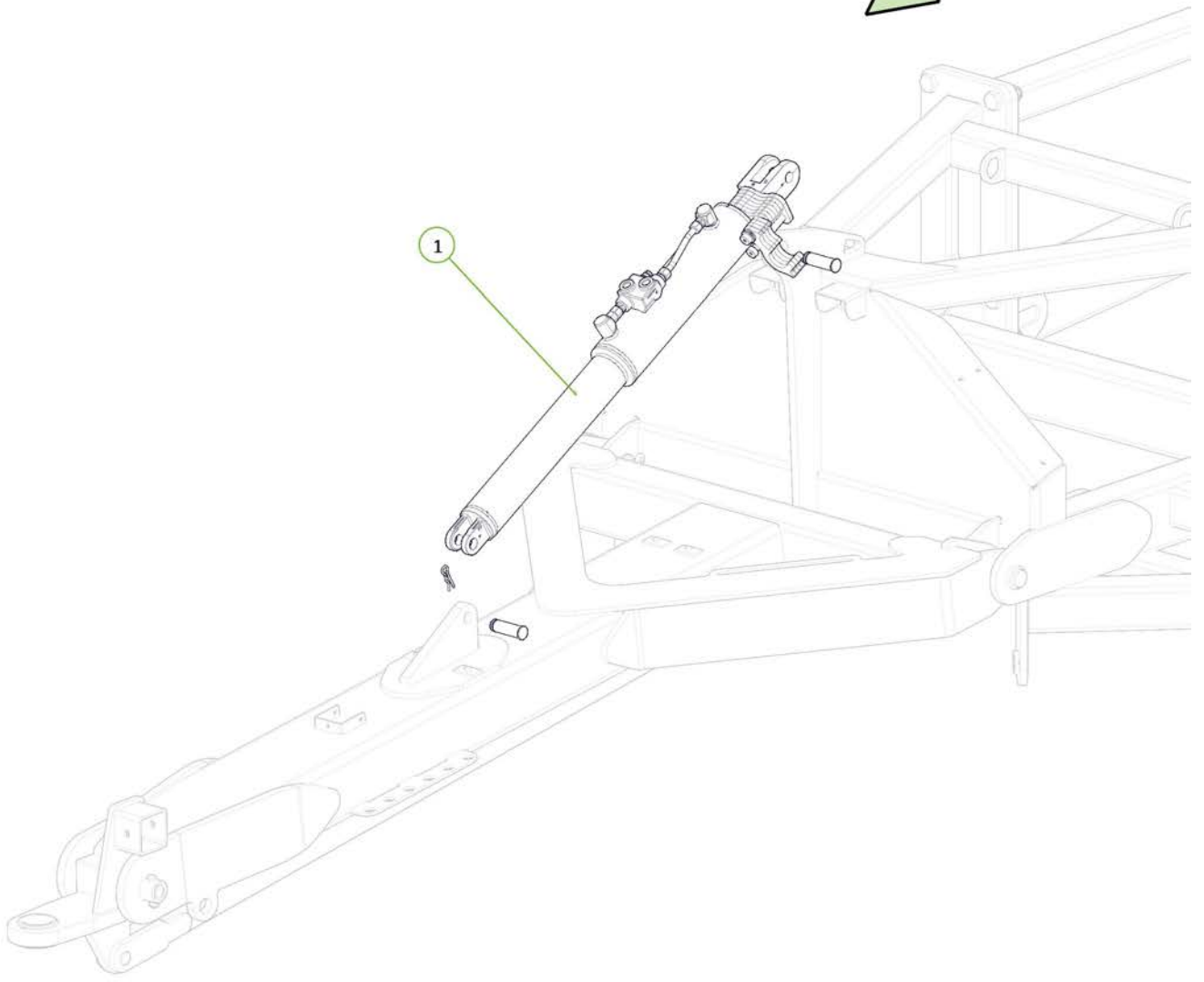
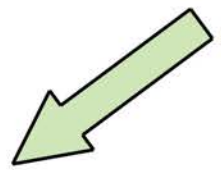

Item No.	Description	Qty	Number
1	Rear A-Frame Front Section	1	1646-03-1
2	Rear A-Frame Rear Section Single King Pin	1	1646-03S-2
3	M20 x 60 grade 8.8 ZP Bolt	16	0211-2060
4	Nyloc Nut M20	16	0221-NYL20

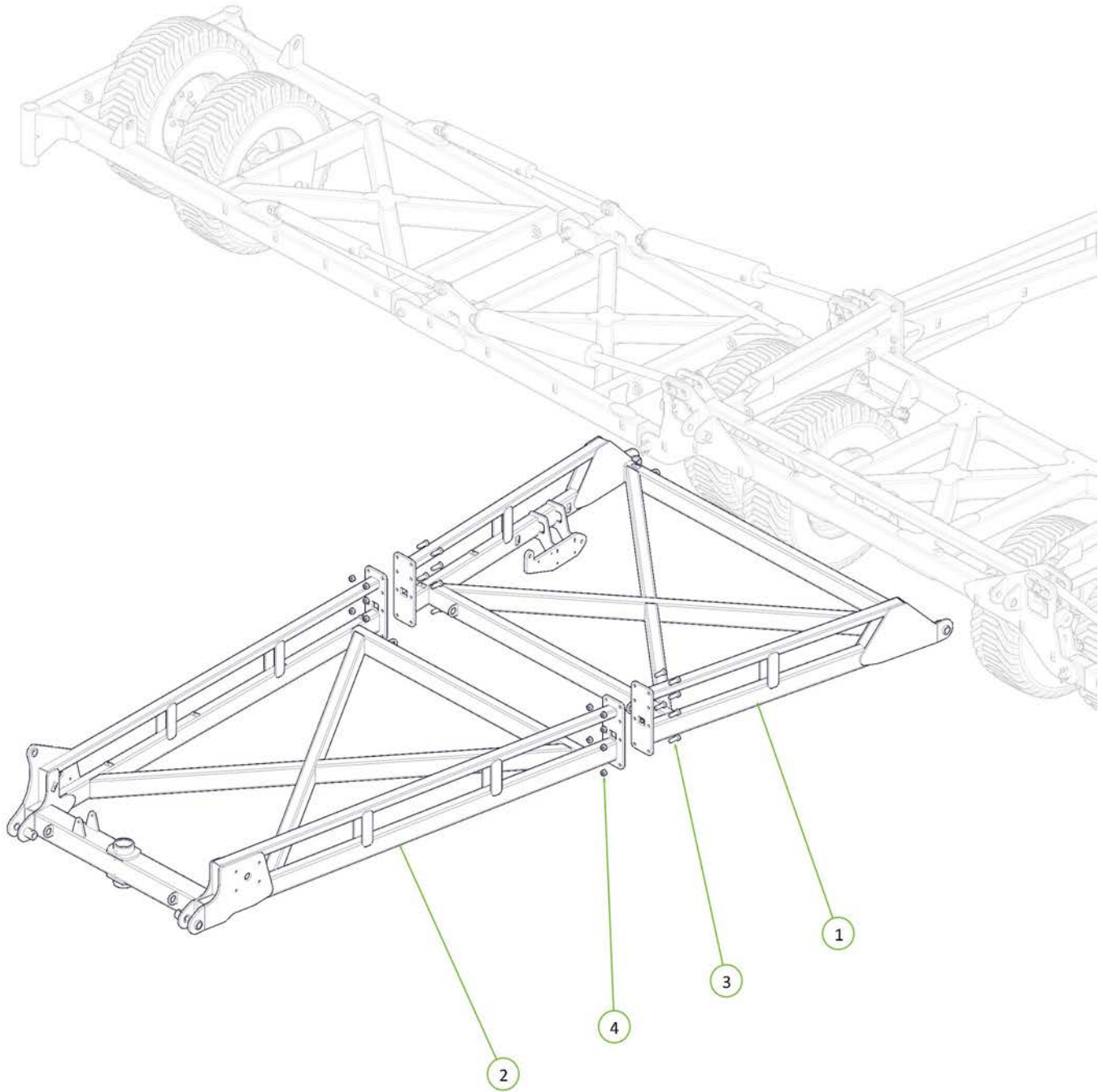
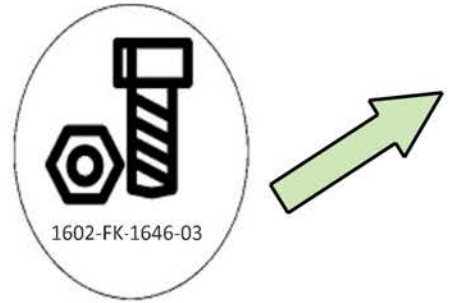

Item No.	Description	Qty	Number
1	35 ID x 30mm DU Bush	4	0113-MB 3530DU
2	PCH Wing Pivot Pin	2	0801-10-08-235
3	Cotter Pin M13 x 63	2	0261-PINC1363
4	M12 x 65 grade 8.8 ZP Bolt	2	0211-1265
5	Nyloc Nut M12	2	0221-NYL12

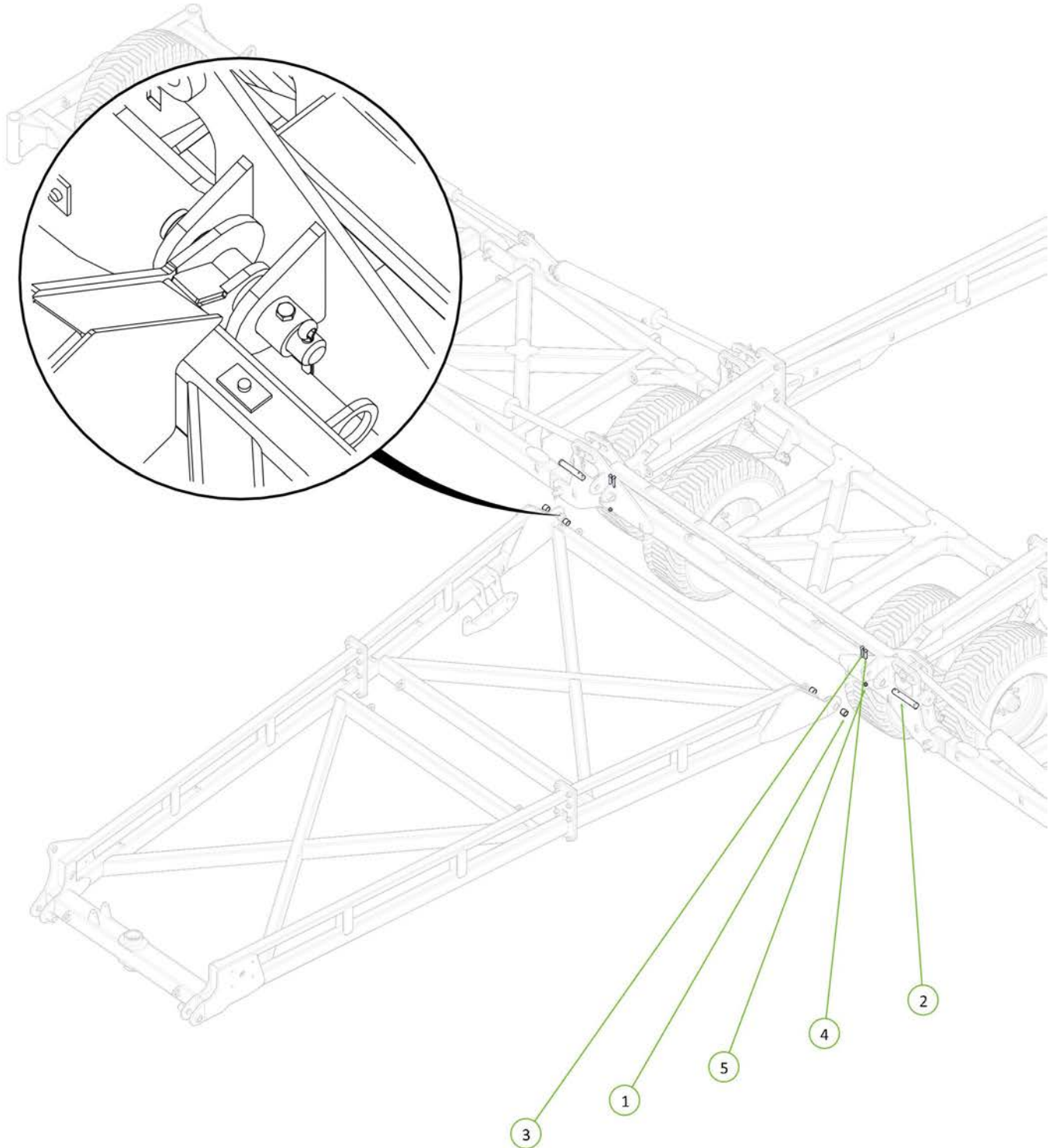



Item No.	Description	Qty	Number
1	Jockey Wheel	1	1610-11-70
2	Plain Spherical Bearing 70mm	2	0113-GE70DO-2RS
3	Circlip Internal 105mm	2	0171-J105
4	35mm Shaft Lock Clamping Element 01	1	0801-LOCK01-35
5	Brake Disc	1	0800-02.1
6	70mm Polymer dust cap	1	0801-KE0705-13
7	Grease Nipple 1/4" UNF	2	0181-GN1-4

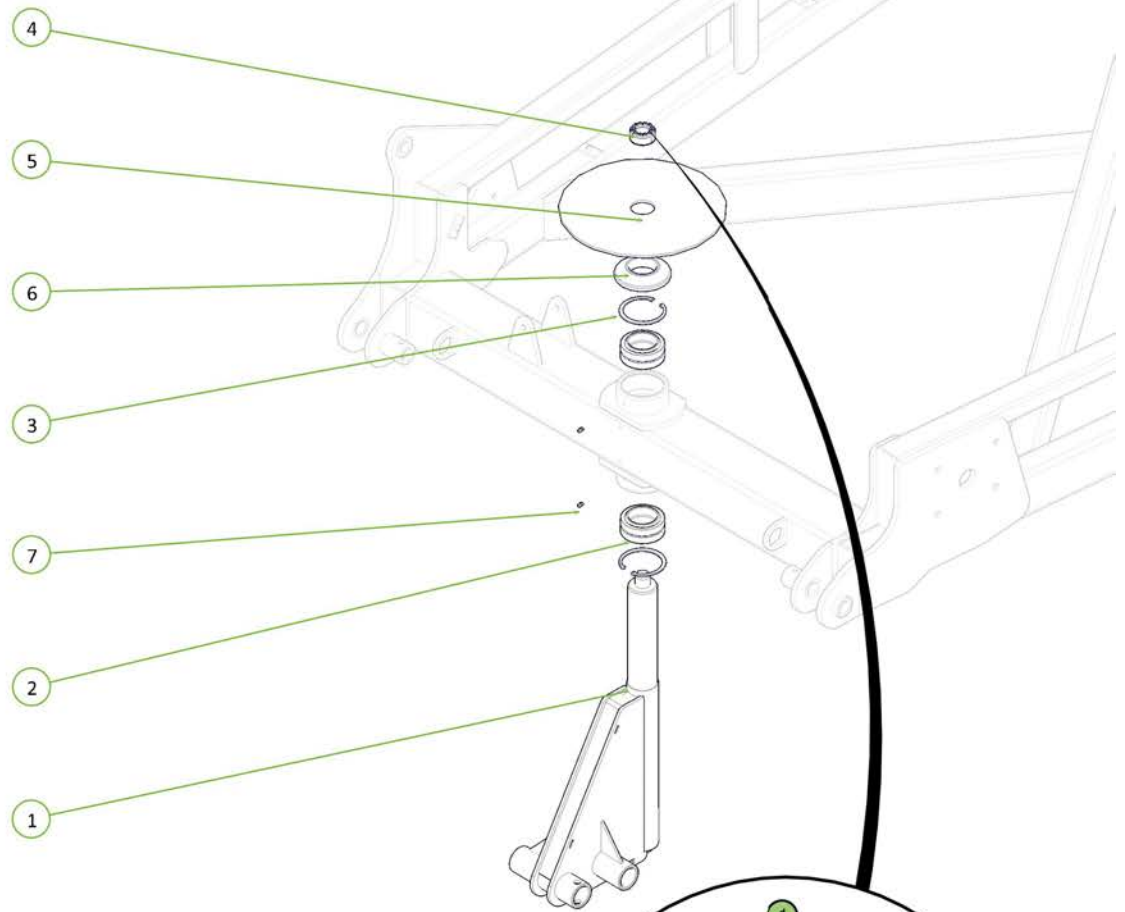

Tighten in a cross pattern,  
 Bring all bolts up equally to 17Nm (12.54 Ft/Lbs)  
 (CAUTION if a single bolt is done up to tension there  
 is a risk of the bolt breaking)

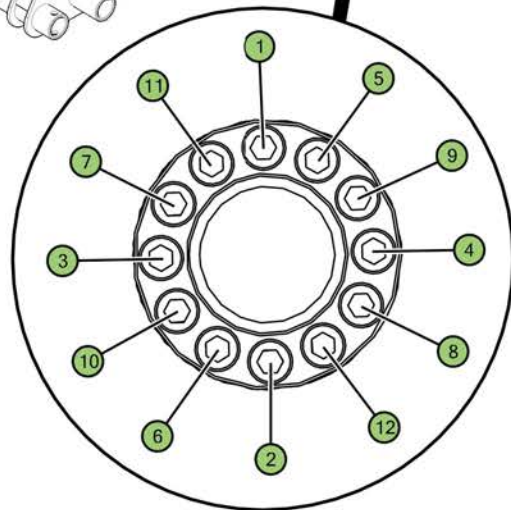
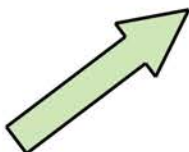

Item No.	Description	Qty	Number
1	Nyloc Nut M16	2	0221-NYL16
2	Axle 2"R 3T 6 on 6"PCD 330 OHF Complete Assembly	2	0733-K5083T66S
3	M16 x 90 grade 8.8 zp Bolt	2	0211-1690

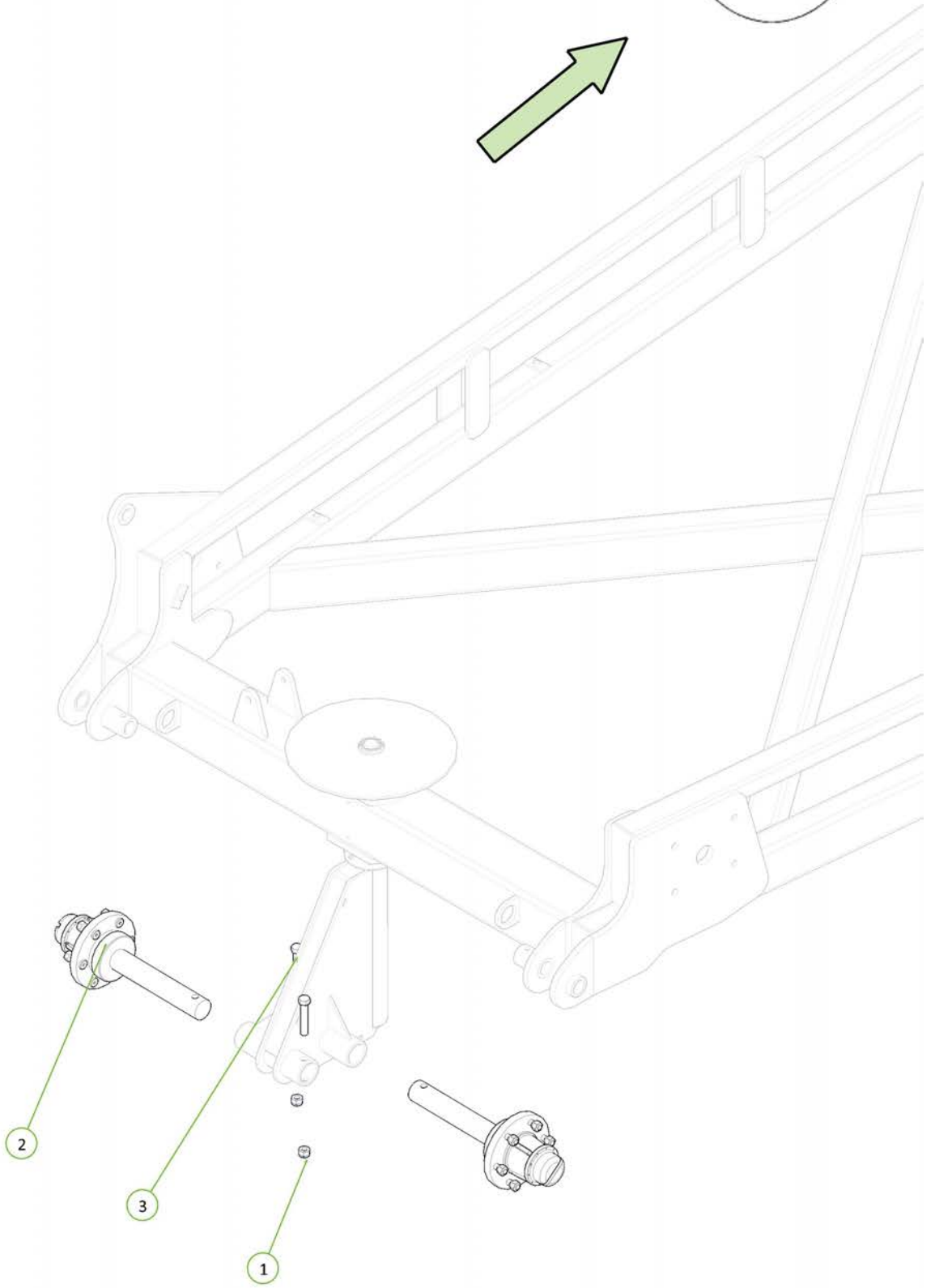

Item No.	Description	Qty	Number
1	11L15 F3 Tyre on 6 on 6" Stud Rim	2	0751-11L15

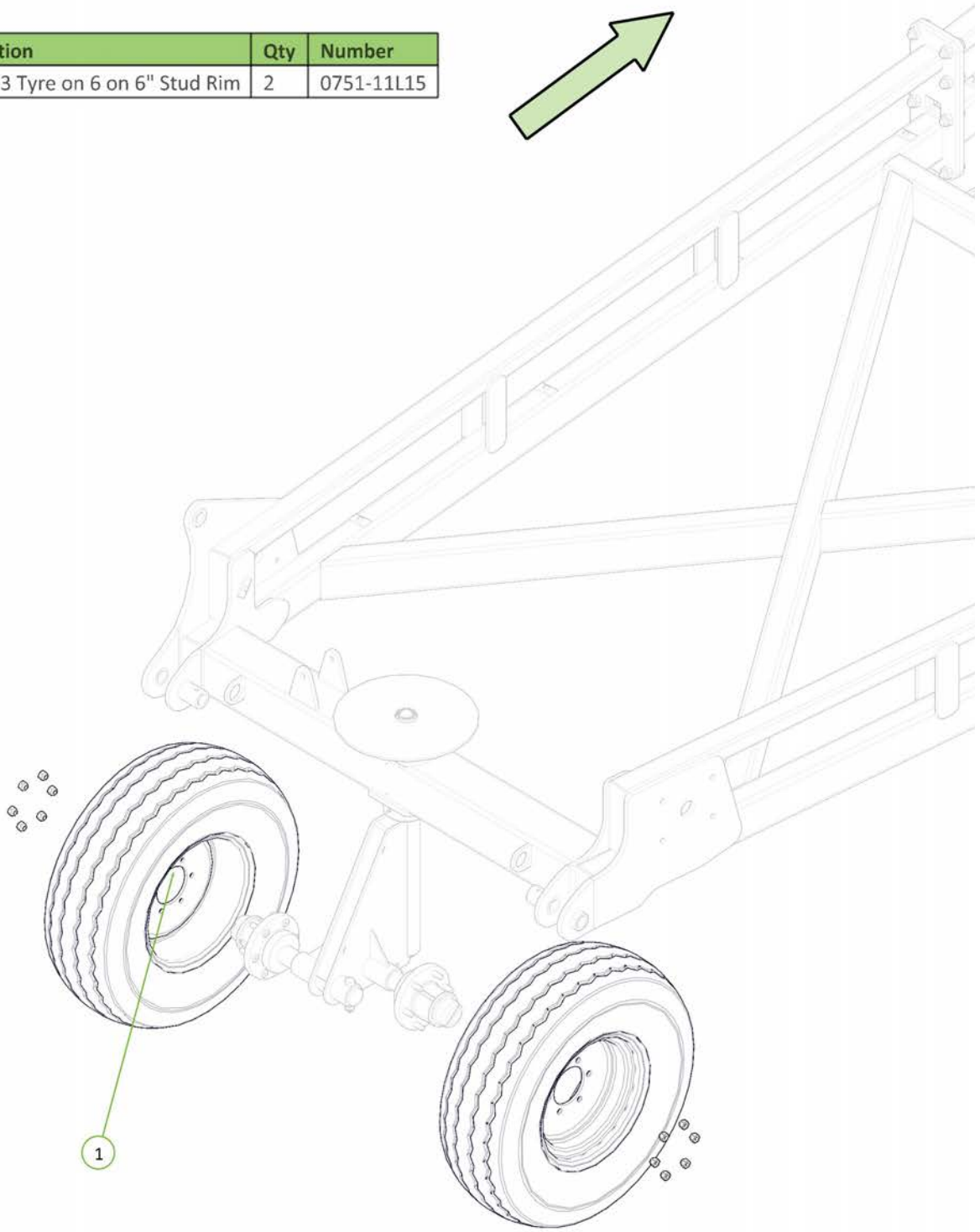
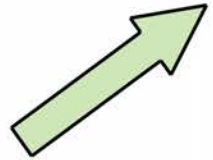

Item No.	Description	Qty	Number
1	Jockey Wheel Brake Caliper	1	0810-12CAL
2	M16 x 150 grade 8.8 zp Bolt	2	0211-16150
3	Nyloc Nut M16	1	0221-NYL16
4	Brake Compression Spring	1	0801-KE009
5	Washer Square M16 x 50 x 5	1	0231-SQ16505

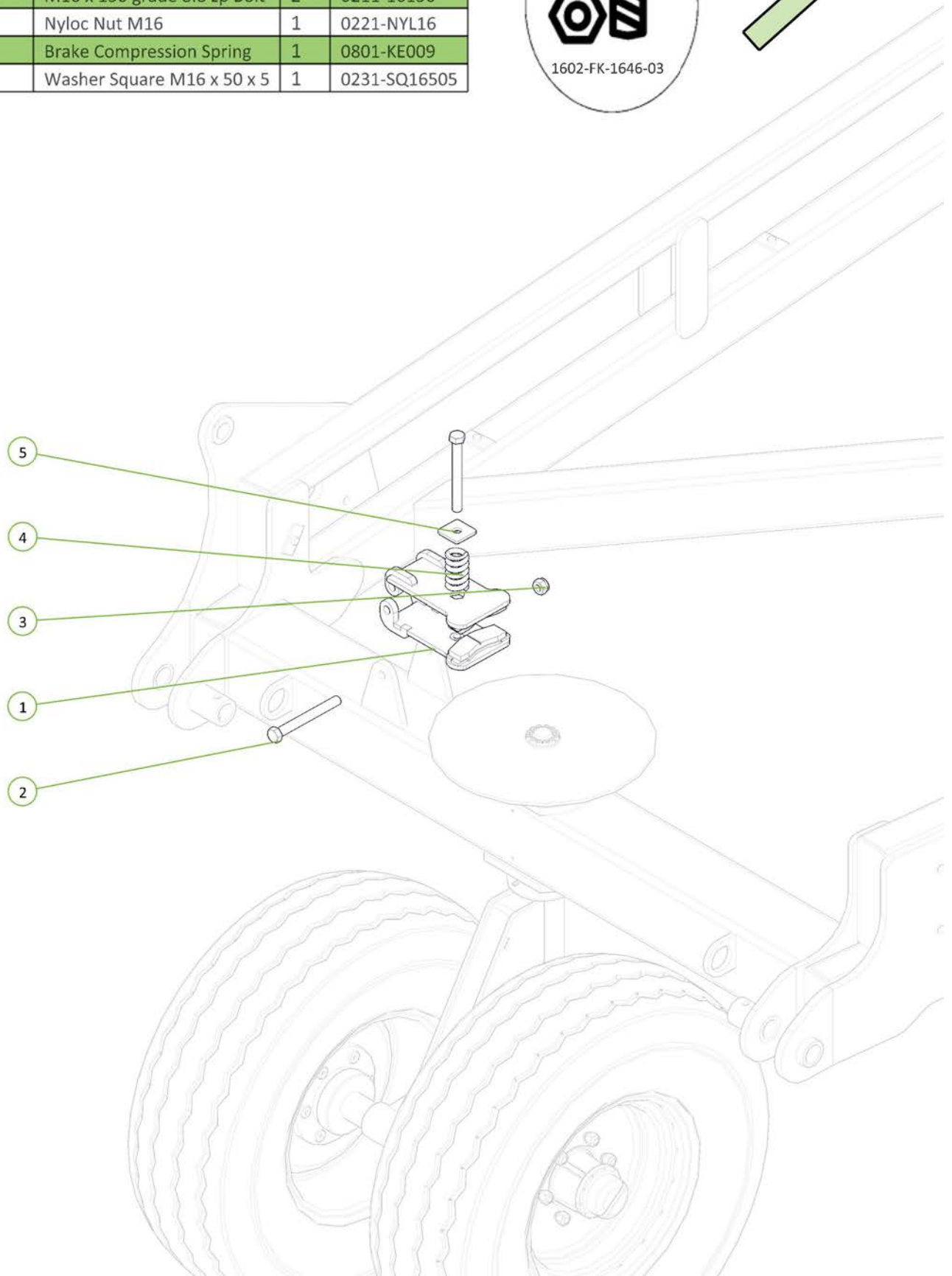
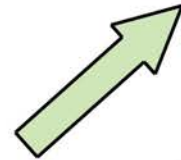

Item No.	Description	Qty	Number
1	Rear Tail	1	1610-10S
2	35 ID x 30mm DU Bush	4	0113-MB 3530DU
3	PCH Wing Pivot Pin	2	0801-10-08-235
4	Cotter Pin M13 x 63	2	0261-PINC1363
5	M12 x 65 grade 8.8 ZP Bolt	2	0211-1265
6	Nyloc Nut M12	2	0221-NYL12

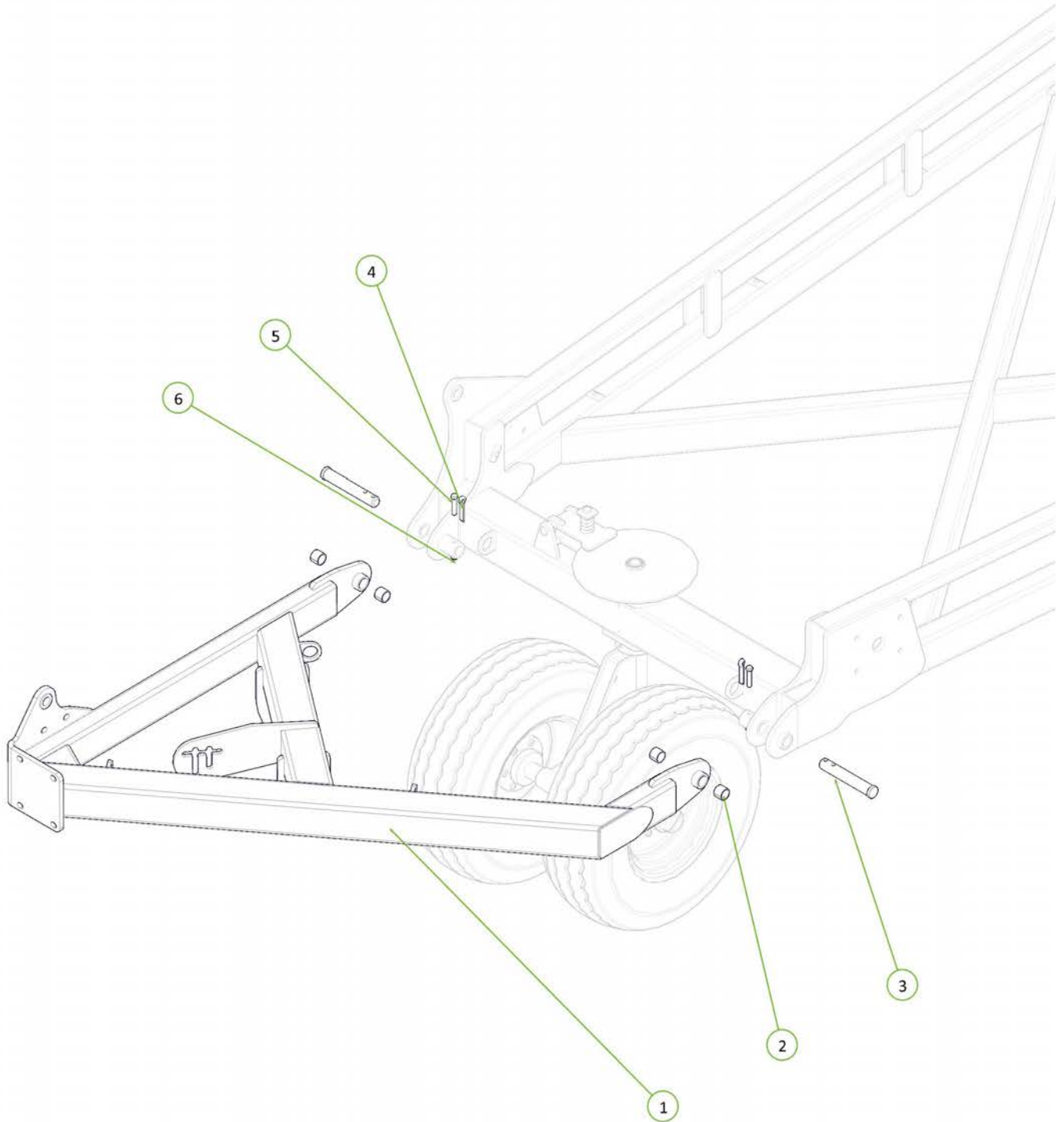
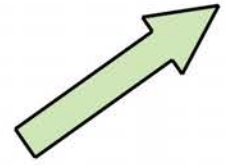

Item No.	Description	Qty	Number
1	4" Bore 24" Stroke 1.75" Rod Hydraulic Cylinder	1	0311-424

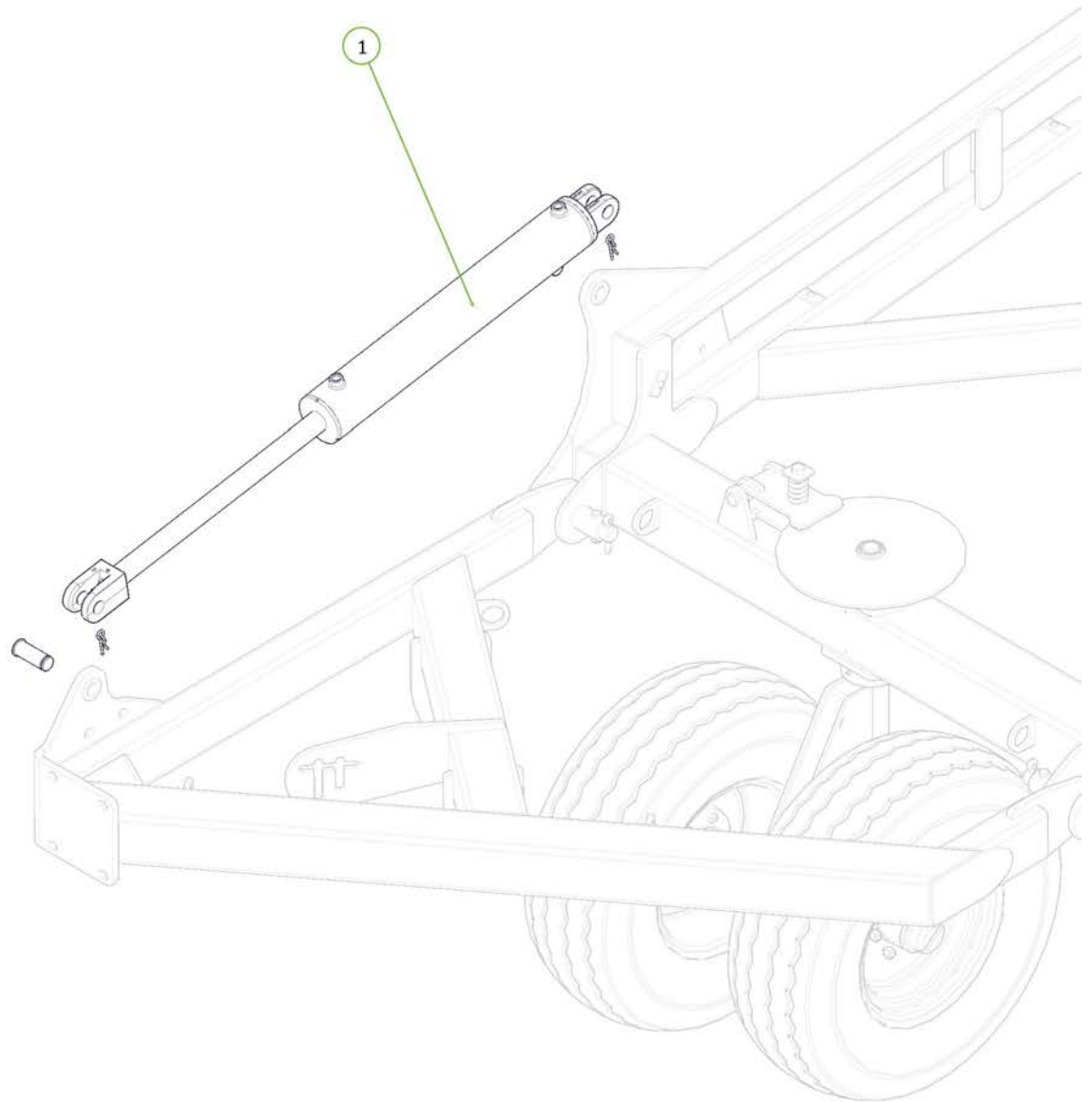
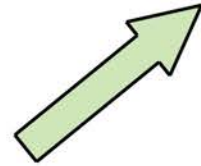

Item No.	Description	Qty	Number
1	Rear Tail Tip	1	1610-10SE
2	M20 x 60 grade 8.8 ZP Bolt	8	0211-2060
3	Nyloc Nut M20	8	0221-NYL20
4	Washer Flat M20	16	0231-F20

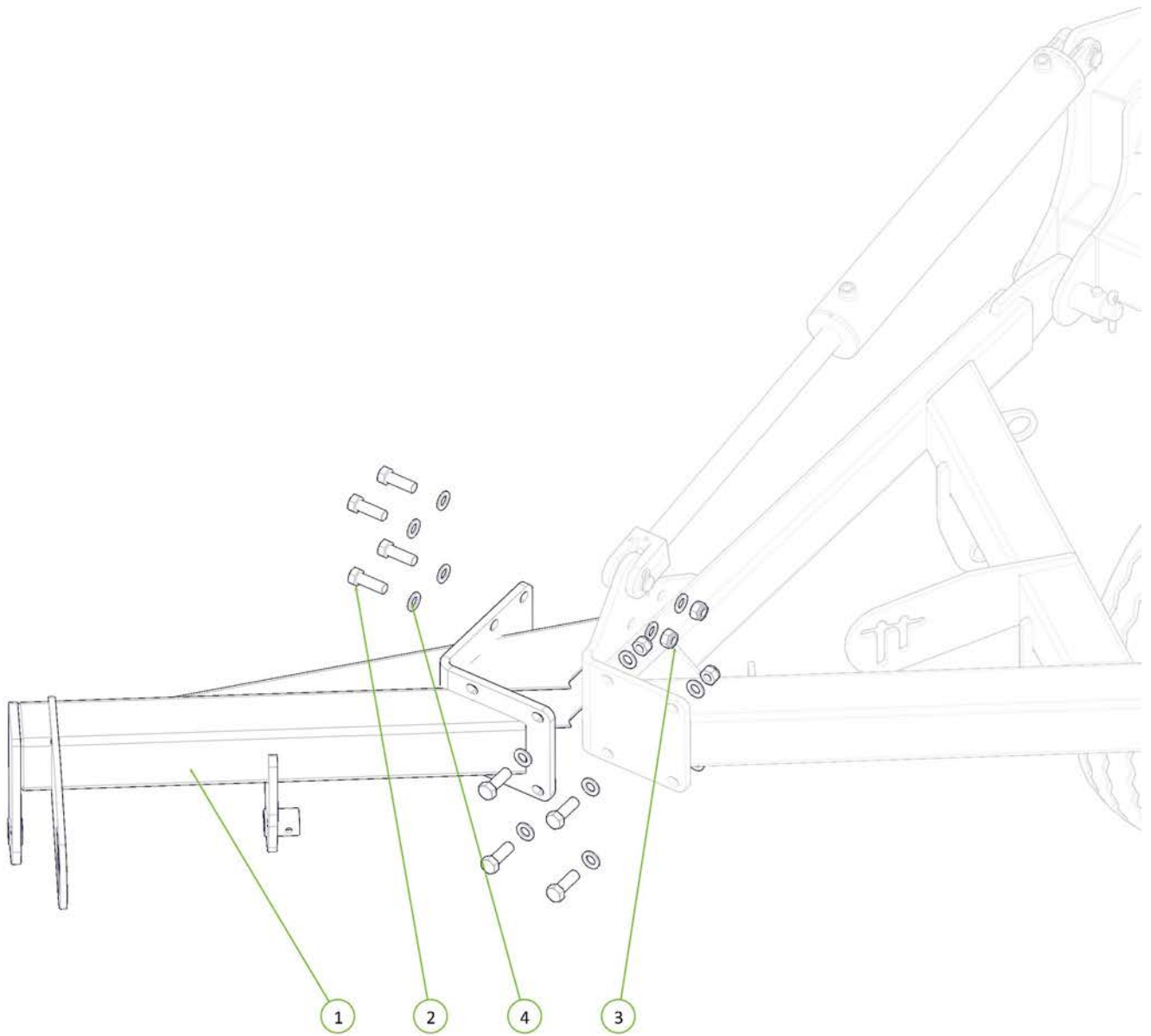
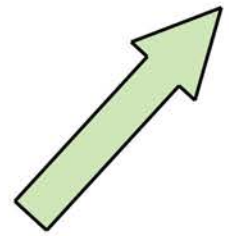

Item No.	Description	Qty	Number
1	46' Front Module Frame	1	1610-28-46
2	U-Bolt M16 x 185 Deep X 104 Wide	8	0271-16185104
3	Washer Flat M16	16	0231-F16
4	Nyloc Nut M16	16	0221-NYL16



**Metric PN - 0271-16185104**  
**Imperial PN - 0271-16190106U**  
**Imperial Description - U-Bolt M16 x 190 Deep x 106 Wide**

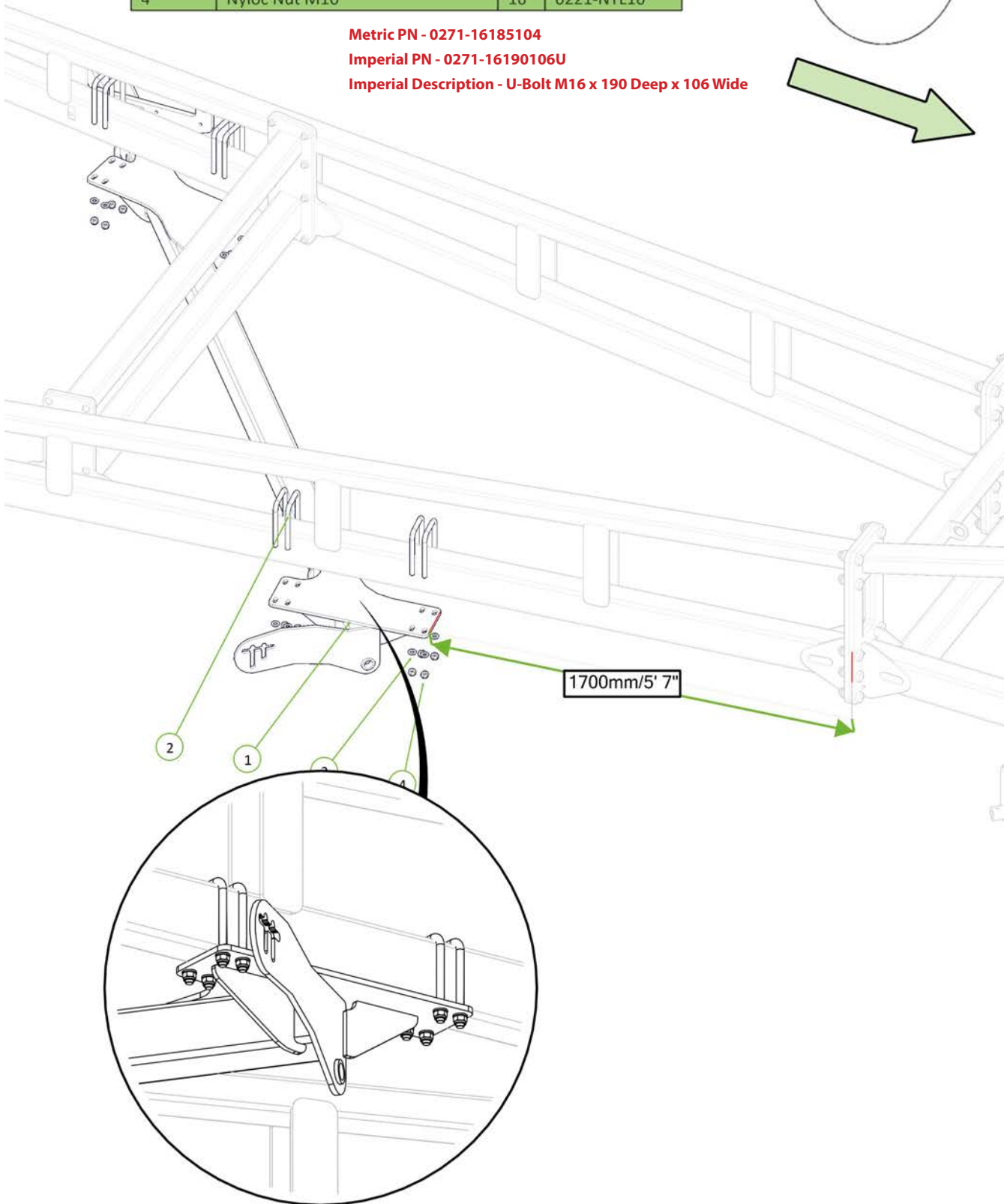
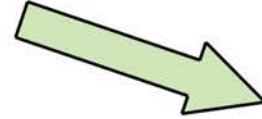



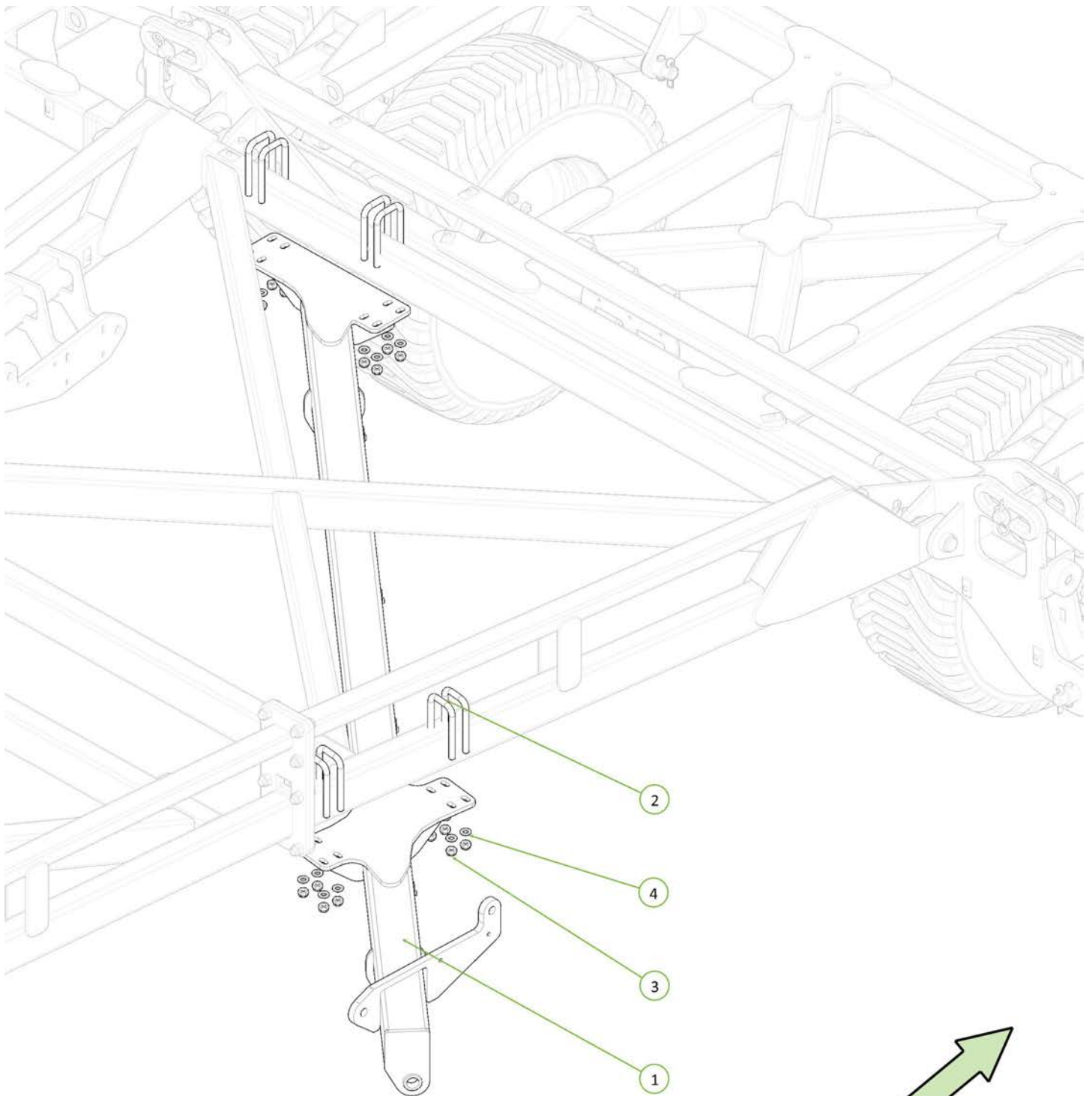

**Metric PN - 0271-1616077**  
**Imperial PN - 0271-161679U**  
**Imperial Description - U-Bolt M16 x 167 Deep X 79 Wide**

Item No.	Description	Qty	Number
1	46' Rear Module Frame	1	1610-29-46
2	U-Bolt M16 x 160 Deep X 77 Wide	8	0271-1616077
3	Nyloc Nut M16	16	0221-NYL16
4	Washer Flat M16	16	0231-F16

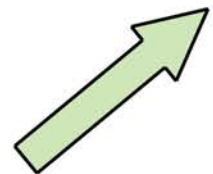

Item No.	Description	Qty	Number
1	46' Inner Wing Post	1	1646-04P
2	M12 x 45 grade 8.8 ZP Bolt	6	0211-1245
3	Nyloc Nut M12	6	0221-NYL12
4	Washer Flat M12	4	0231-F12

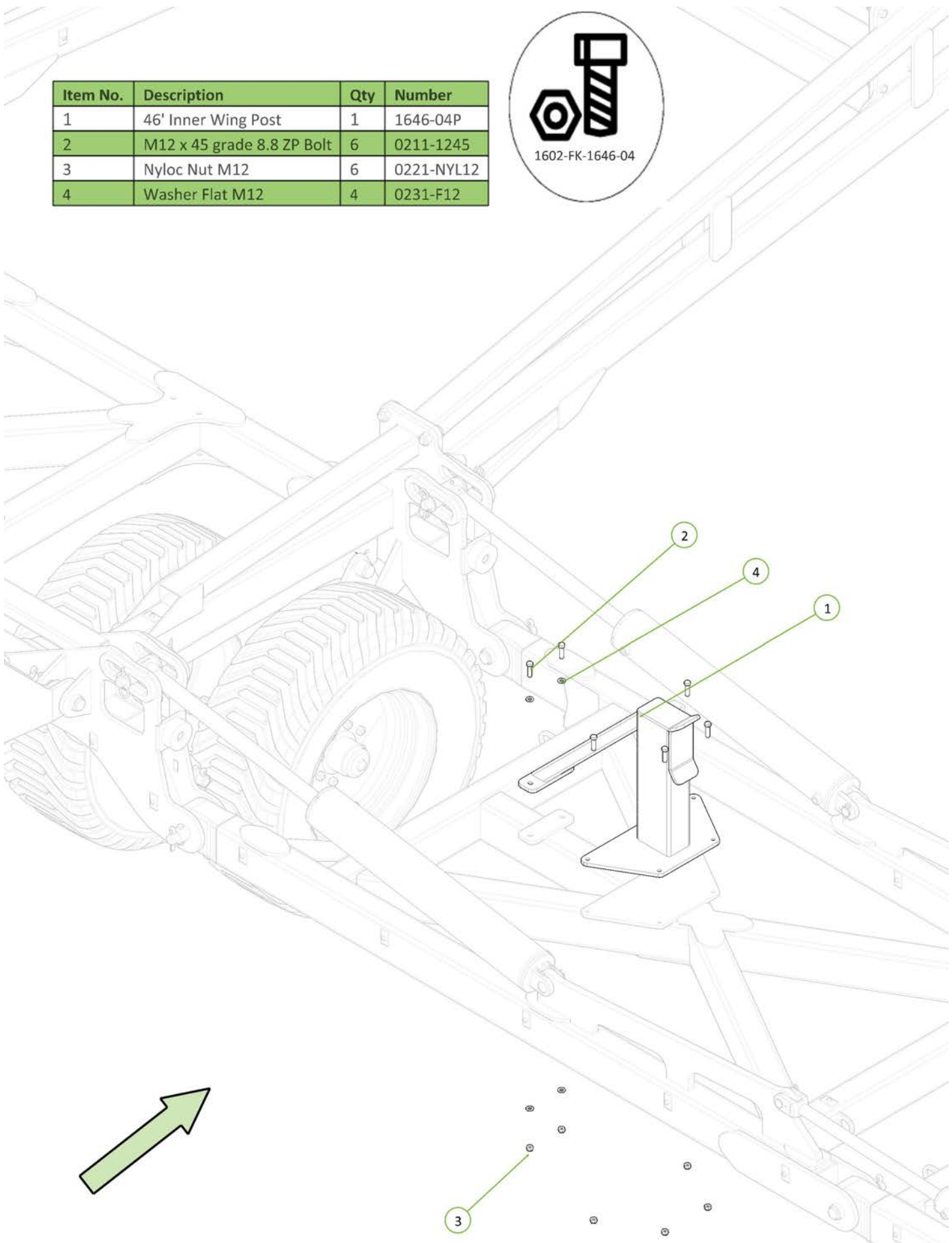

Item No.	Description	Qty	Number
1	46' Outer Wing Post	1	1646-06P
2	M12 x 40 grade 8.8 ZP Bolt	4	0211-1240
3	Nyloc Nut M12	4	0221-NYL12

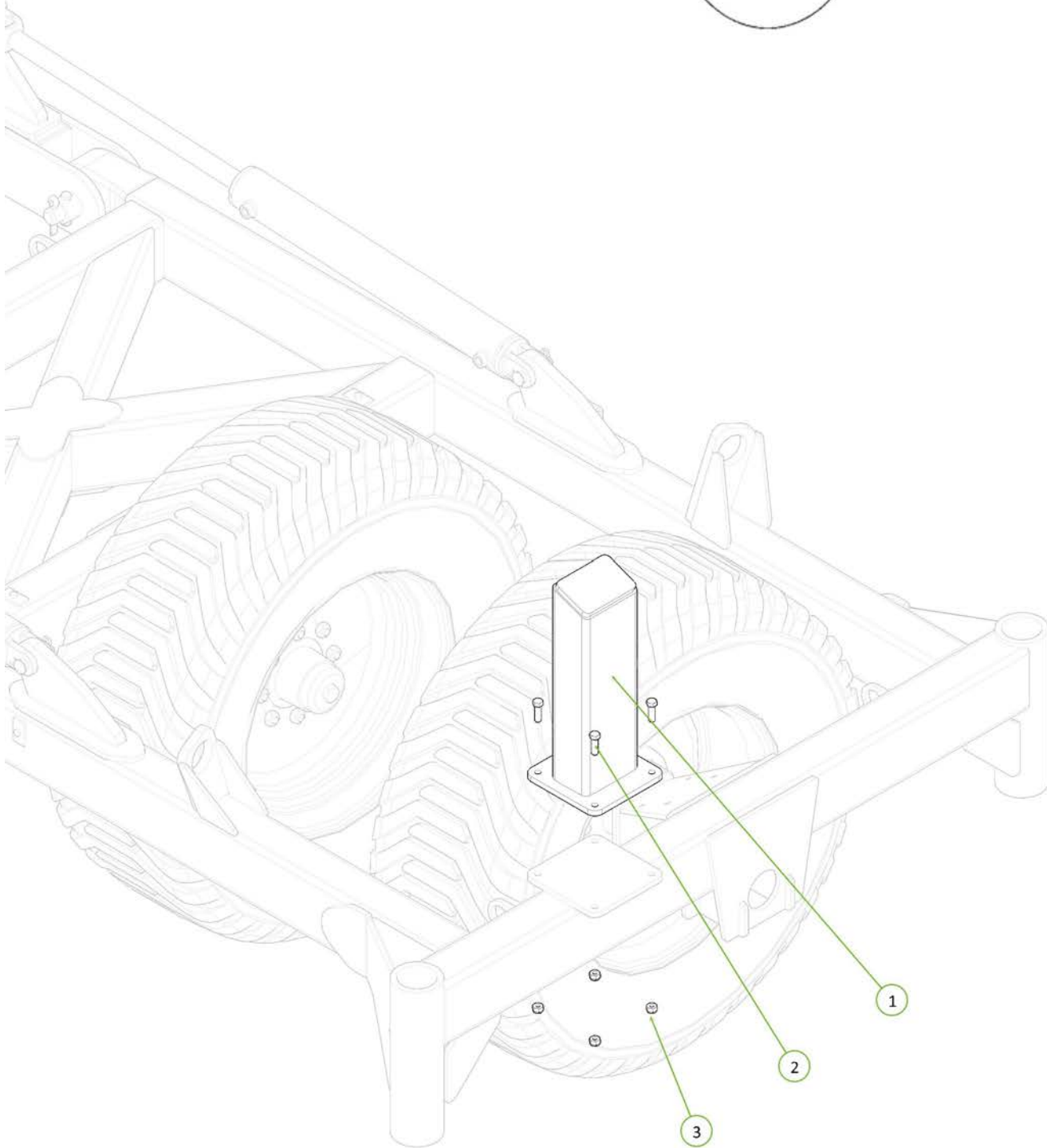
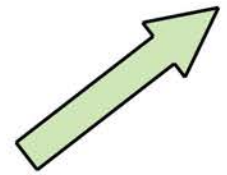

Item No.	Description	Qty	Number
1	Drawbar Post Assy	1	1610-370
2	M8 x 20 grade 8.8 ZP Bolt	3	0211-820
3	Nyloc Nut M8	3	0221-NYL8

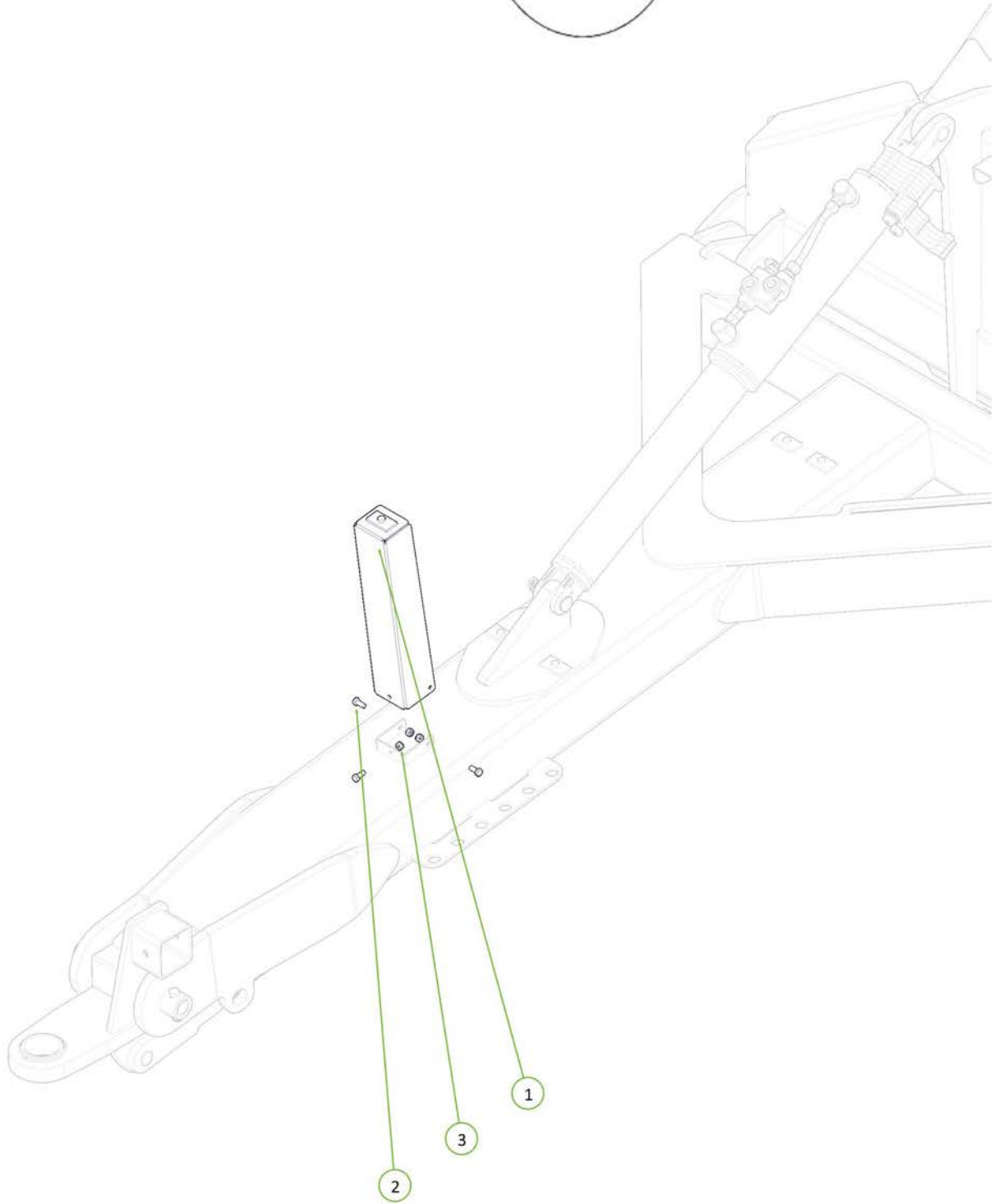
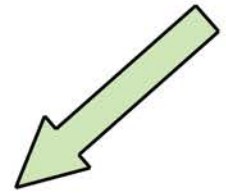

Item No.	Description	Qty	Number
1	LH Dropleg No Clevis	1	0810-24F
2	RH Dropleg No Clevis	1	0810-25F
3	LH Chain Adjusting Lug	1	0810-26
4	RH Chain Adjusting Lug	1	0810-27
5	Forged Clevis 21mm Bolt Hole	2	0801-FC21
6	Stainless Steel Wear Bush	2	1501-365033-SS
7	M36 x 105 grade 8.8 ZP Bolt	2	0211-36105
8	M24 x 140 grade 8.8 zp Bolt	2	0211-24140
9	Nyloc Nut M24	2	0221-NYL24
10	Nyloc Nut M36	2	0221-NYL36

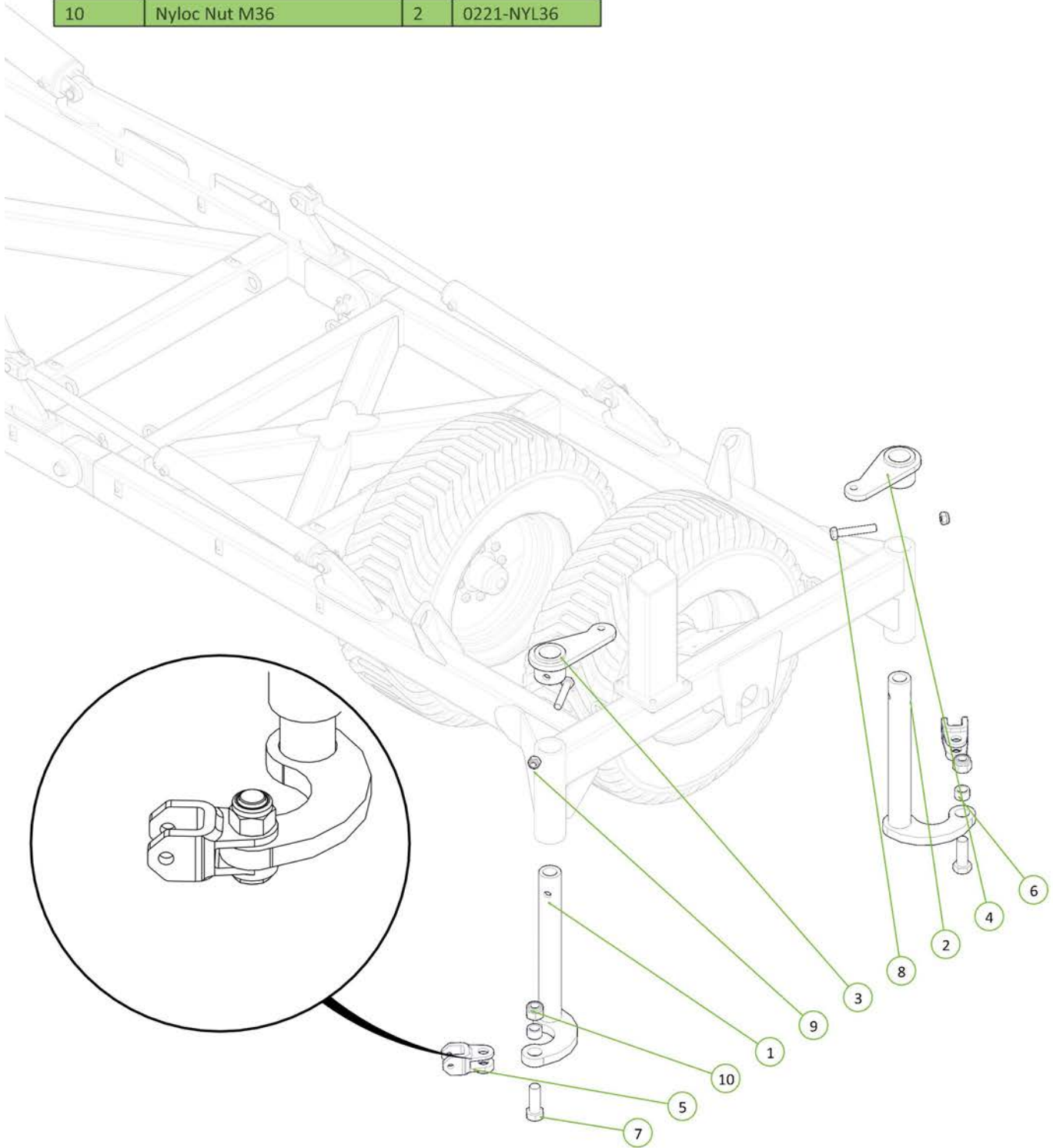
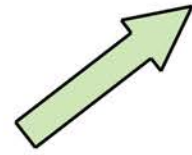

Item No.	Description	Qty	Number
1	25mm Drop Leg Spacer Half	20	0801-CS25
2	M10 x 30 grade 8.8 ZP Bolt	20	0211-1030
3	Nyloc Nut M10	20	0221-NYL10

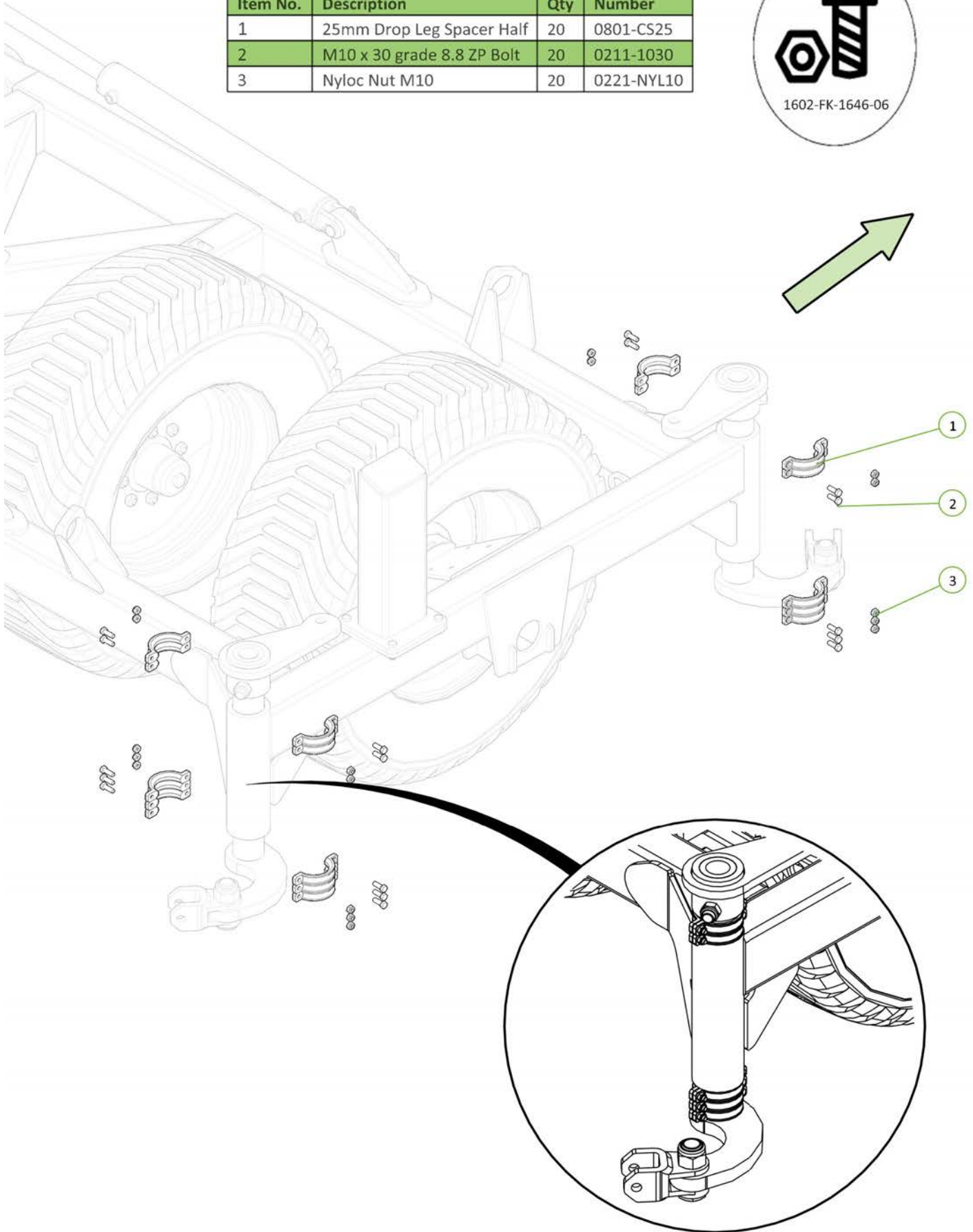

Item No.	Description	Qty	Number
1	Chain Tension Adjustor	2	0802-PCHTA
2	WASHER HIGH TENSILE 1 1/4"	2	0232-HT11-4
3	20mm Compression Spring, Black	2	0801-XK9261S
4	Tensioner Cup - Male	2	0801-KE0805-3
5	Tensioner Cup-Female	2	0801-KE0805-4

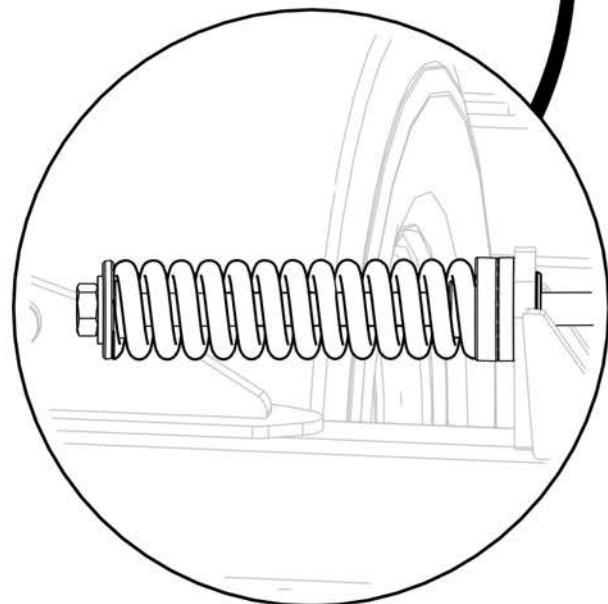
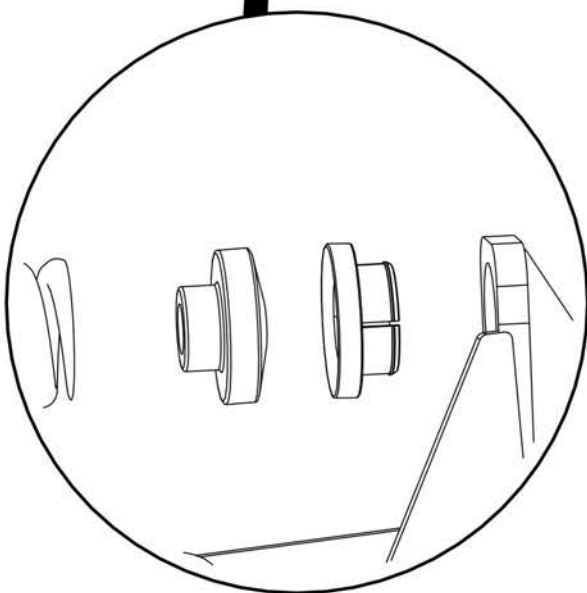
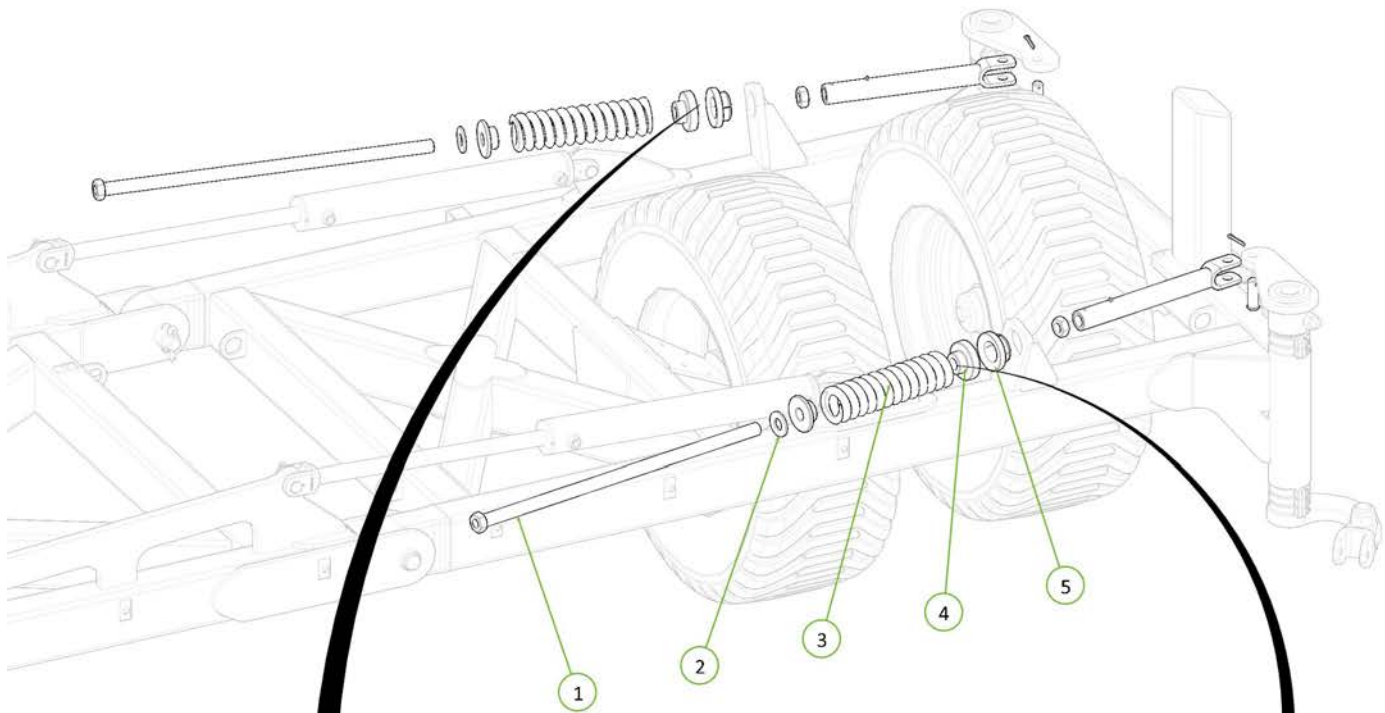
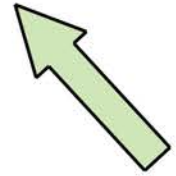

Item No.	Description	Qty	Number
1	LH Dropleg No Clevis	1	0810-24F
2	RH Dropleg No Clevis	1	0810-25F
3	RH Chain Adjusting Lug	1	0810-27
4	LH Chain Adjusting Lug	1	0810-26
5	Stainless Steel Wear Bush	2	1501-365033-SS
6	Forged Clevis 21mm Bolt Hole	2	0801-FC21
7	M36 x 105 grade 8.8 ZP Bolt	2	0211-36105
8	M24 x 140 grade 8.8 zp Bolt	2	0211-24140
9	Nyloc Nut M24	2	0221-NYL24
10	Nyloc Nut M36	2	0221-NYL36

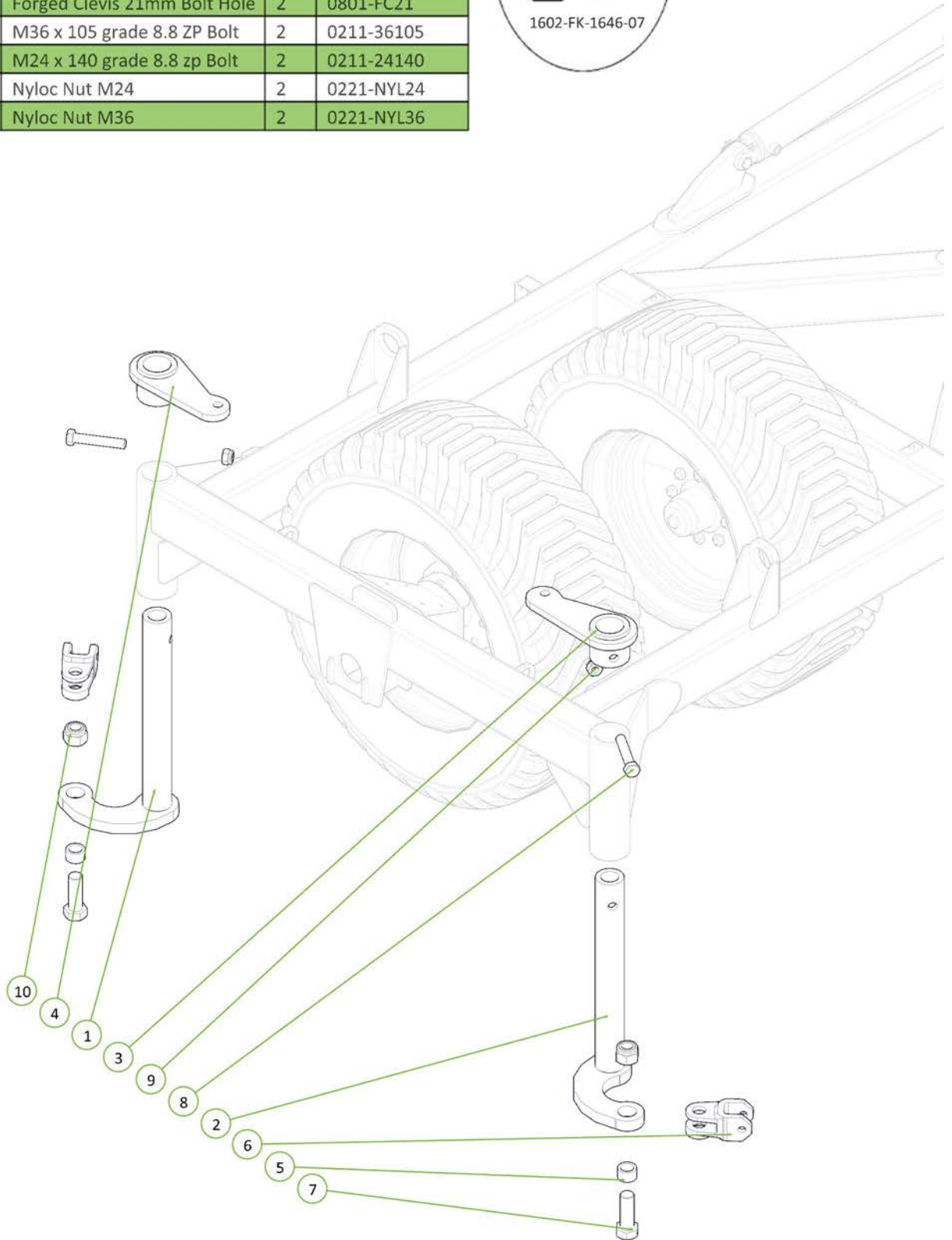
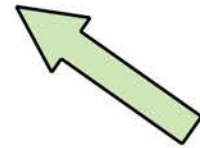



Item No.	Description	Qty	Number
1	25mm Drop Leg Spacer Half	20	0801-CS25
2	M10 x 30 grade 8.8 ZP Bolt	20	0211-1030
3	Nyloc Nut M10	20	0221-NYL10

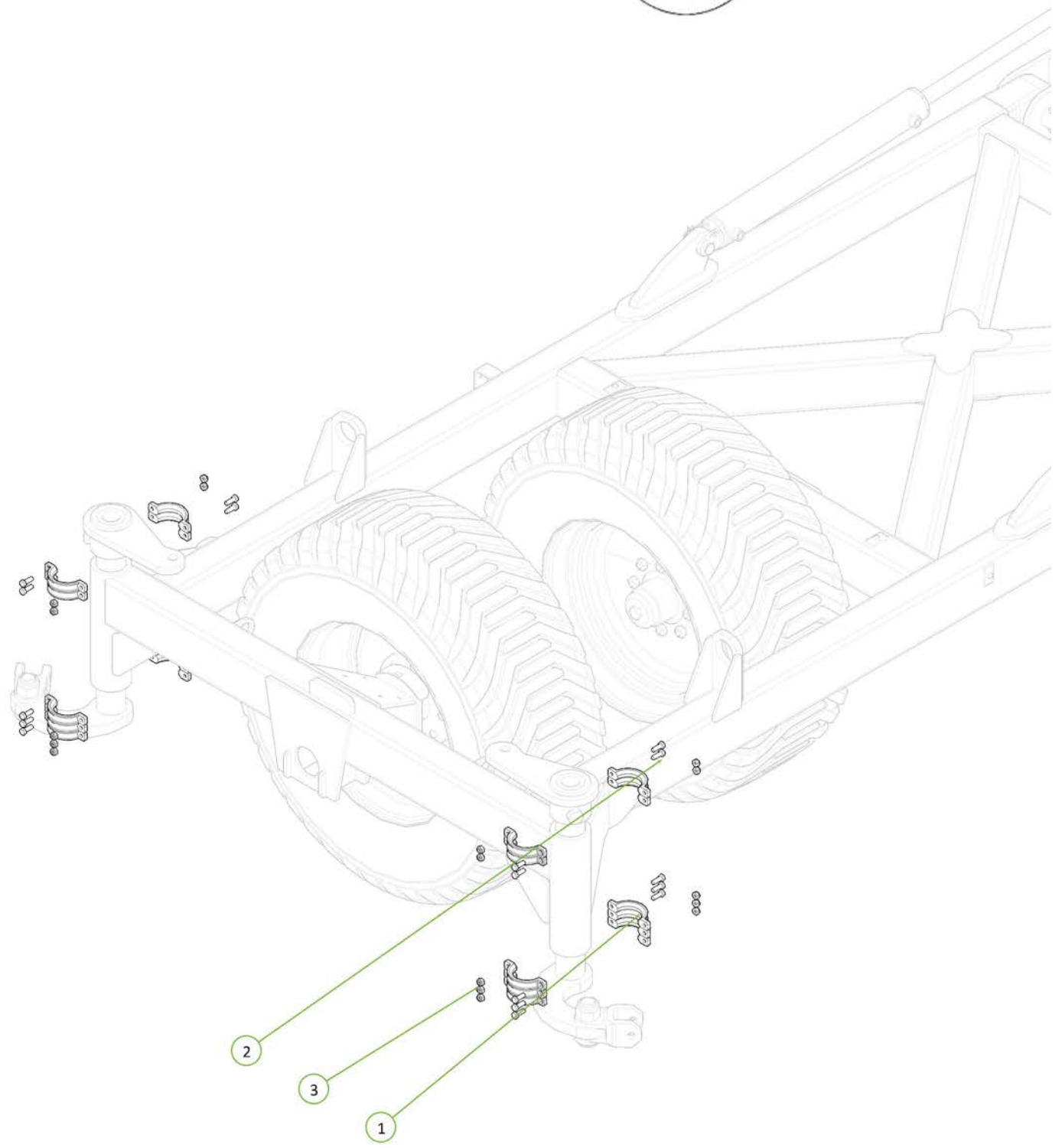
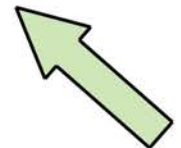

Item No.	Description	Qty	Number
1	Chain Tension Adjustor	2	0802-PCHTA
2	WASHER HIGH TENSILE 1 1/4"	2	0232-HT11-4
3	20mm Compression Spring, Black	2	0801-XK9261S
4	Tensioner Cup - Male	2	0801-KE0805-3
5	Tensioner Cup-Female	2	0801-KE0805-4

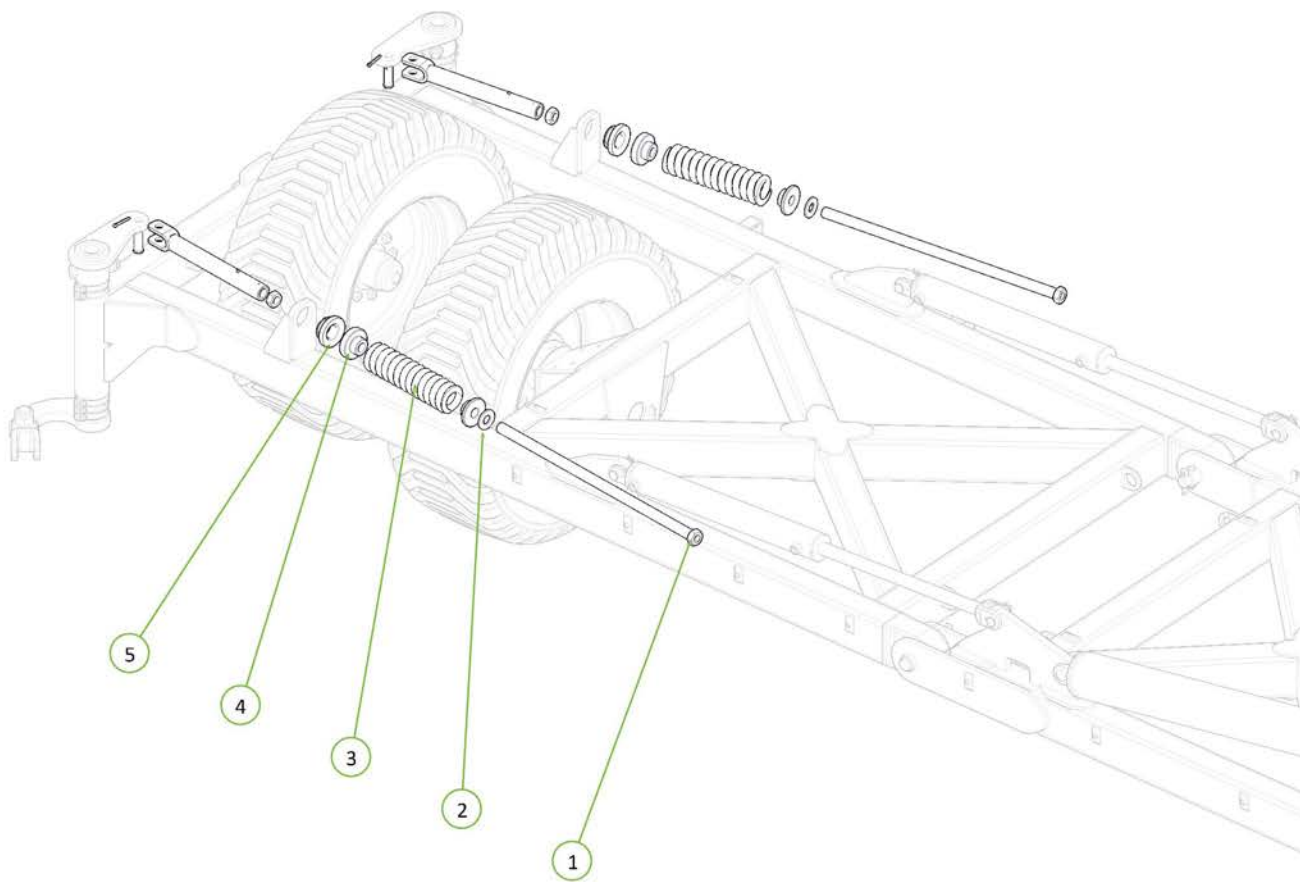
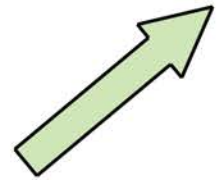

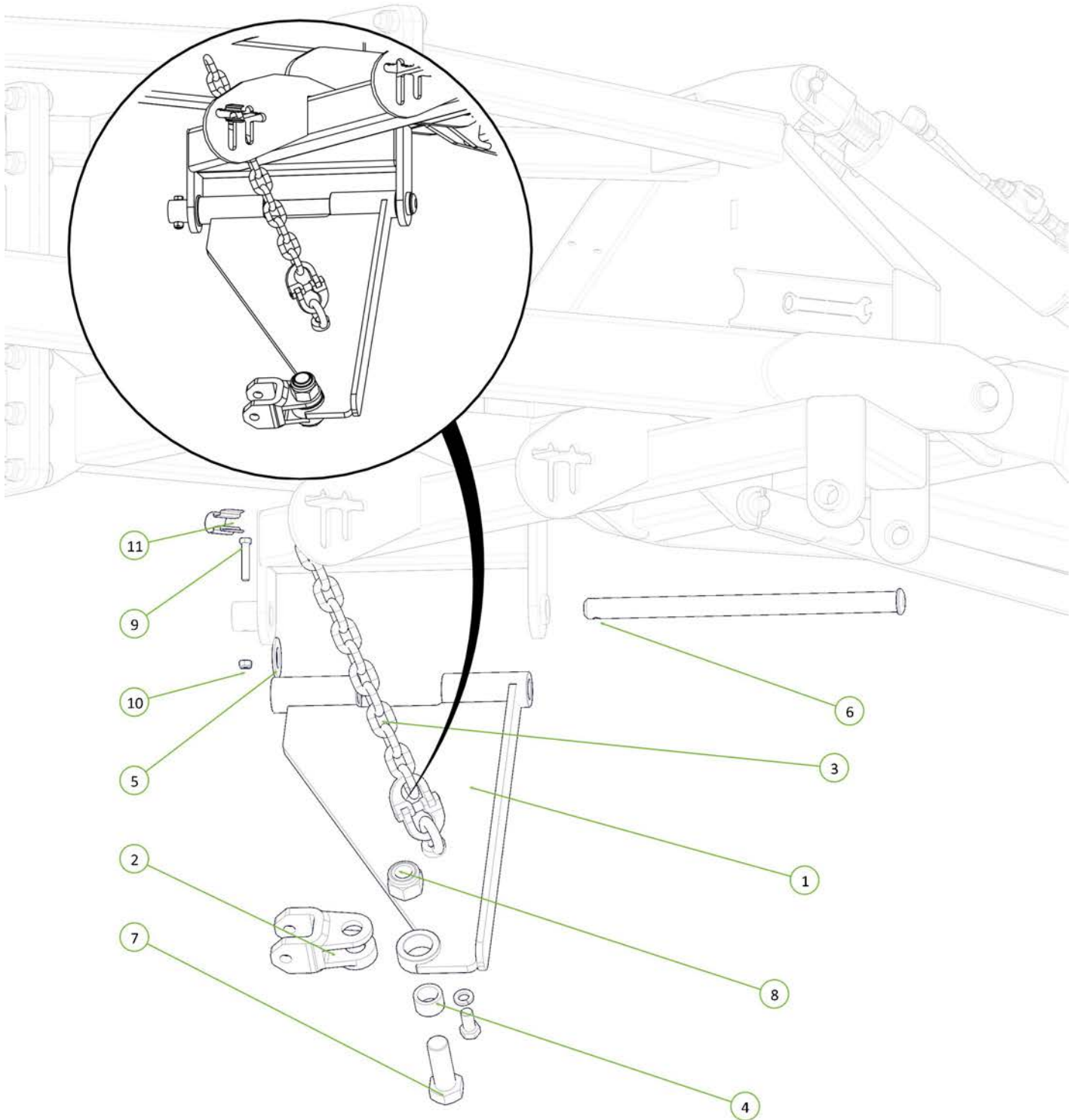

Item No.	Description	Qty	Number
1	Standard Chain Mount Plate	1	1610-20
2	Forged Clevis 21mm Bolt Hole	1	0801-FC21
3	Height Adjusting Chain Assembly 13 Link	1	0801-20MCA
4	Stainless Steel Wear Bush	1	1501-365033-SS
5	Washer High Tensile 1 3/8"	1	0232-HT13-8
6	Chain Mount Pivot Pin	1	0801-10-51
7	M36 Grade 8.8 ZP Bolt	1	0211-36105
8	Nyloc Nut M36	1	0221-NYL36
9	M12 x 65 grade 8.8 ZP Bolt	1	0211-1265
10	Nyloc Nut M12	1	0221-NYL12
11	Height Adjustor Retaining Clip	1	0801-KE014

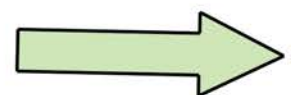

High tensile washer to load side

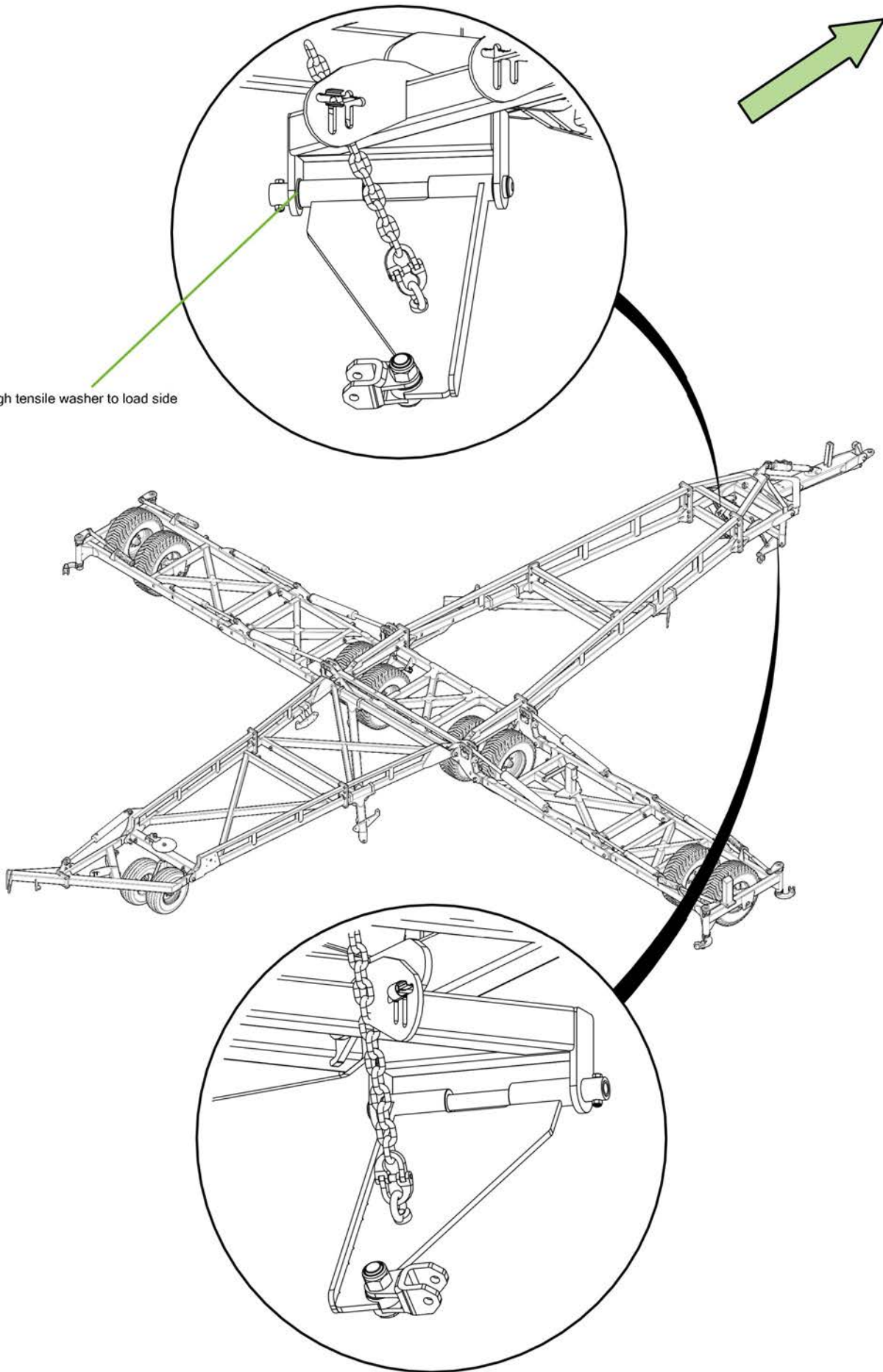

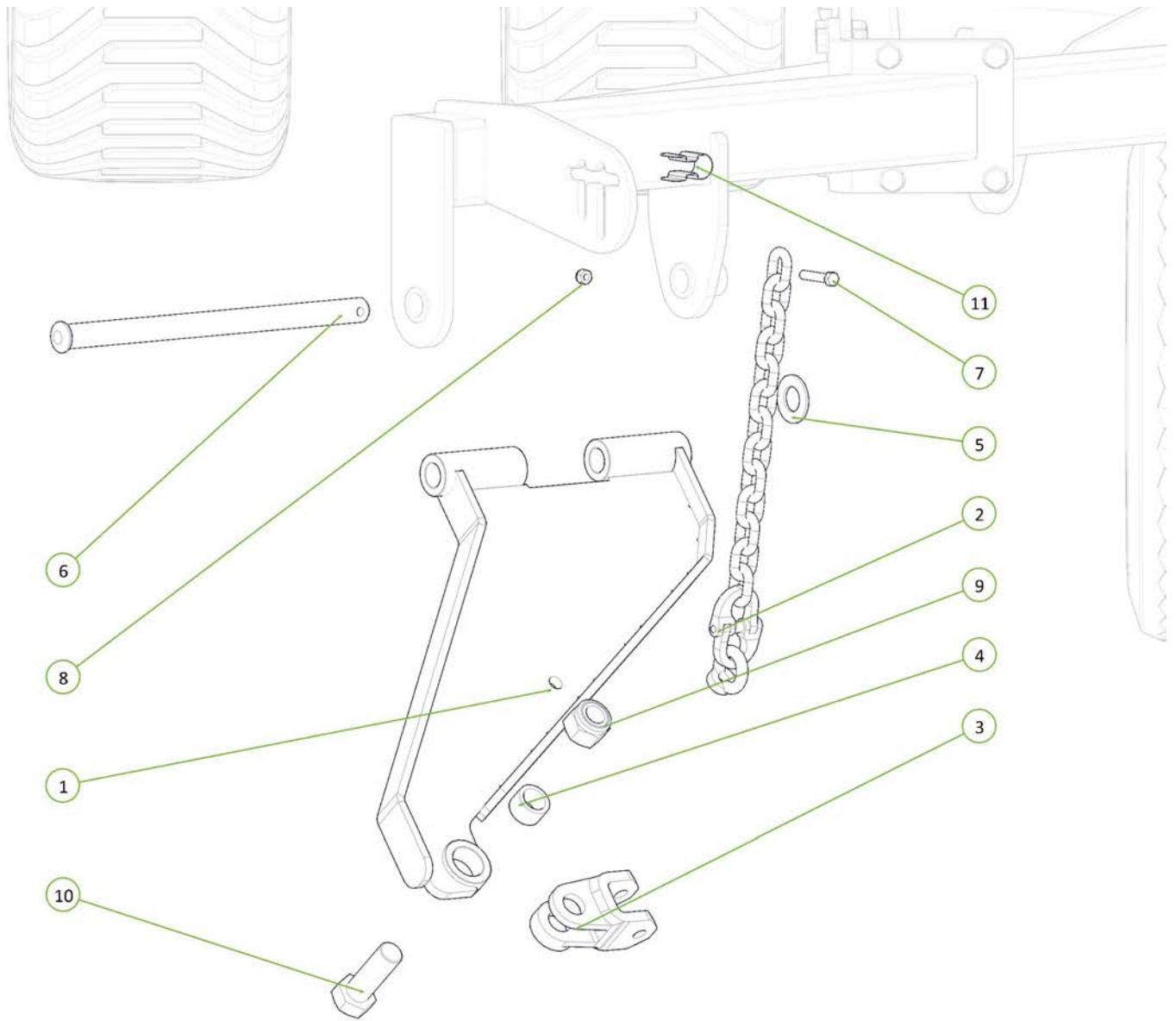

Item No.	Description	Qty	Number
1	Extended Chain Mount Plate	1	1610-21
2	Height Adjusting Chain Assembly 13 Link	1	0801-20MCA
3	Forged Clevis 21mm Bolt Hole	1	0801-FC21
4	Stainless Steel Wear Bush	1	1501-365033-SS
5	Washer High Tensile 1 3/8"	1	0232-HT13-8
6	Chain Mount Pivot Pin	1	0801-10-51
7	M12 x 65 grade 8.8 ZP Bolt	1	0211-1265
8	Nyloc Nut M12	1	0221-NYL12
9	Nyloc Nut M36	1	0221-NYL36
10	M36 x 105 grade 8.8 zp Bolt	1	0211-36105
11	Height Adjustor Retaining Clip	1	0801-KE014

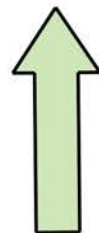

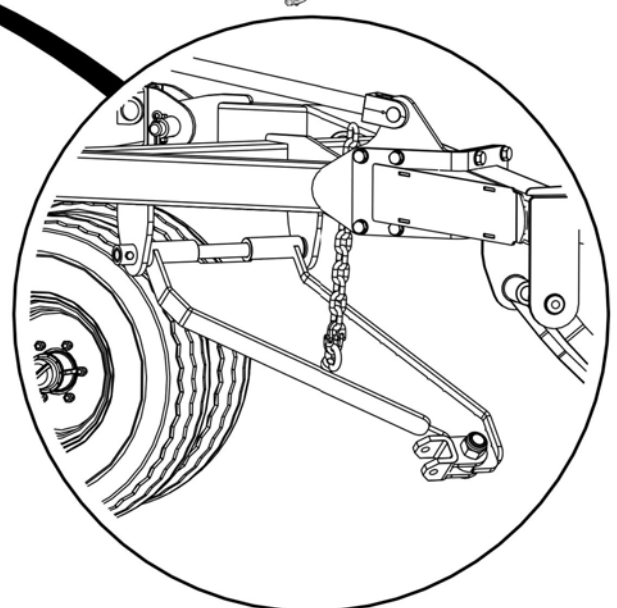
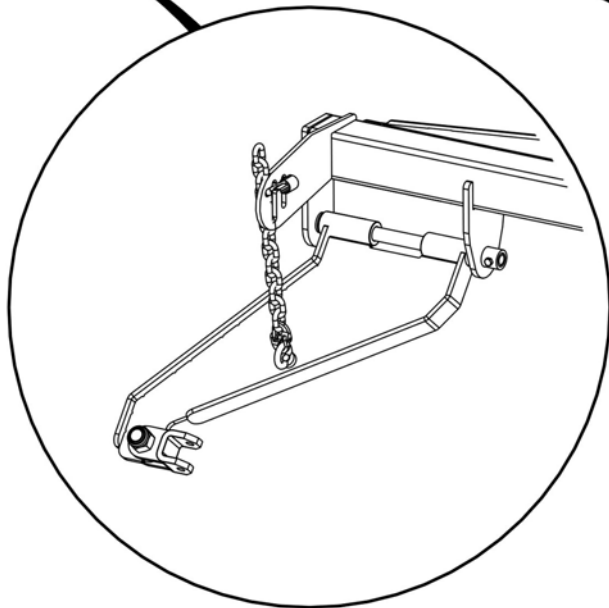
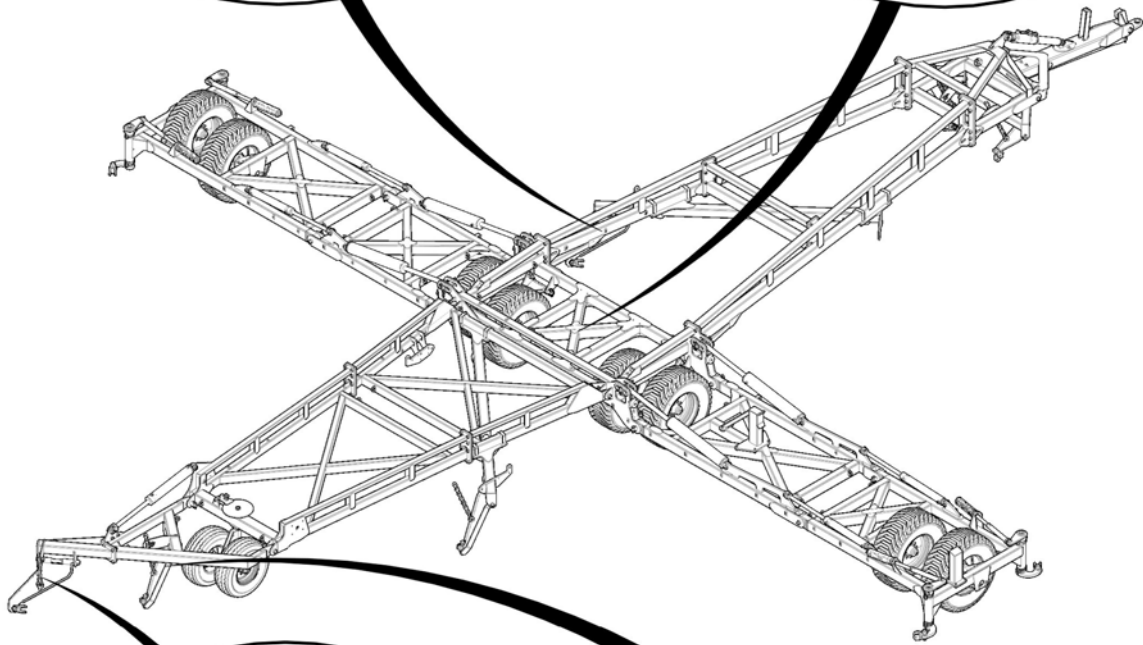
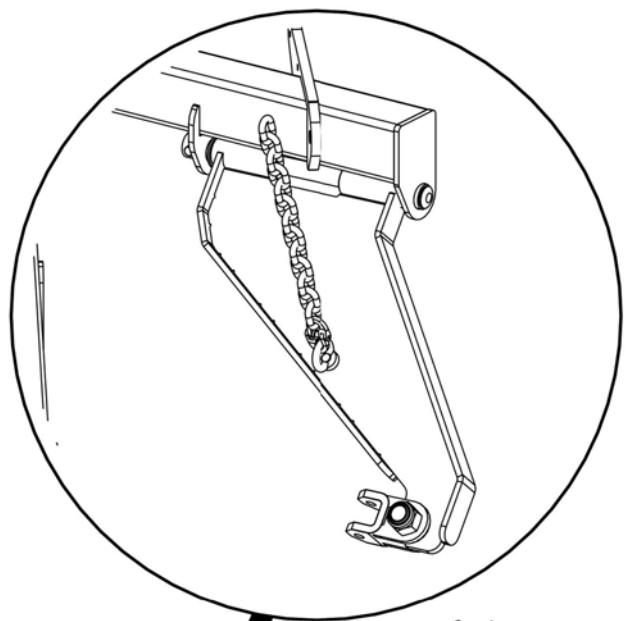
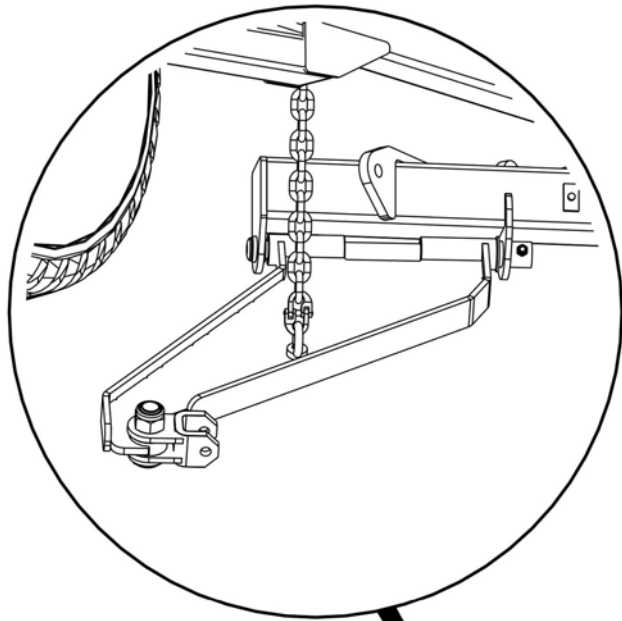

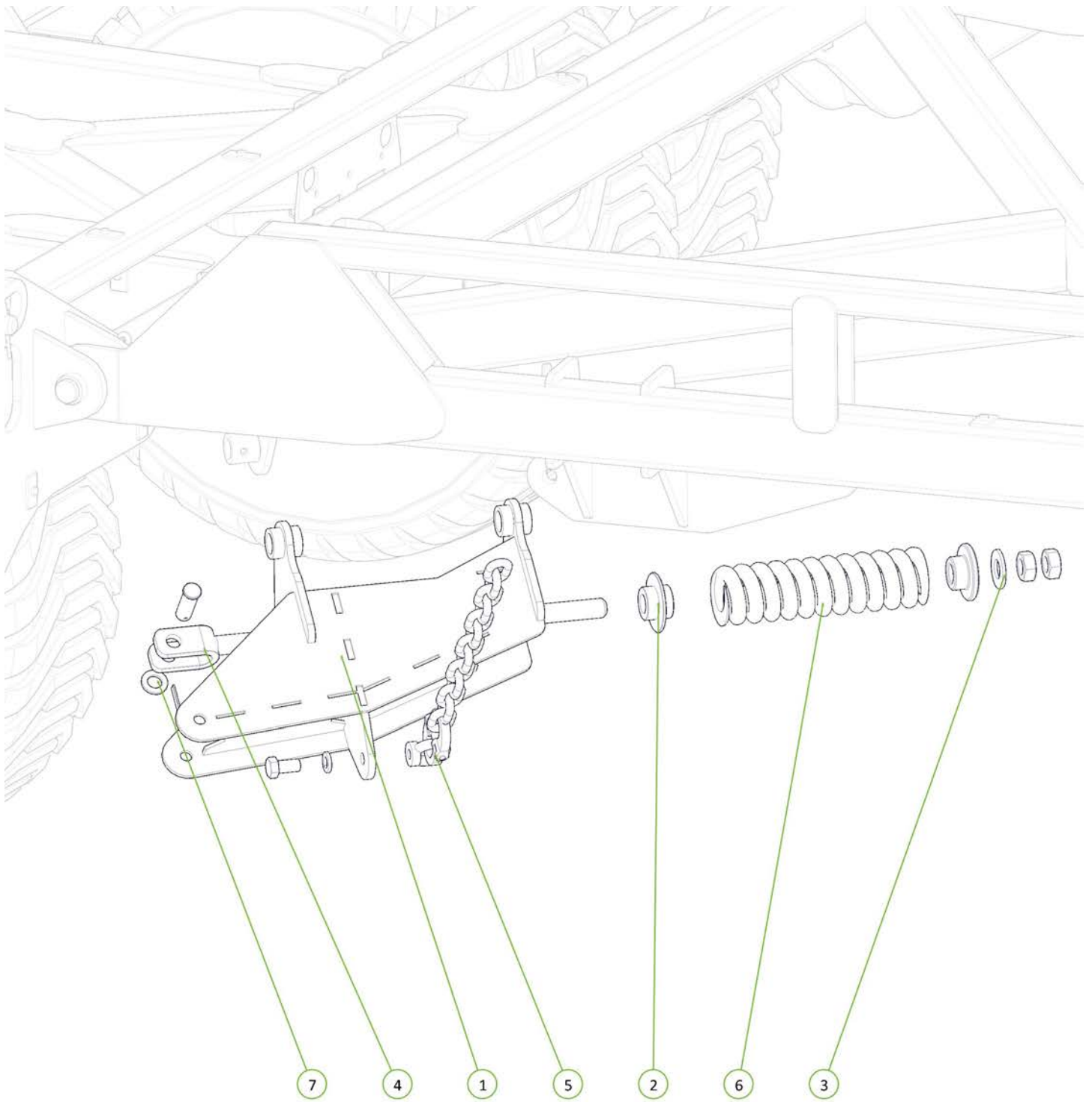

Item No.	Description	Qty	Number
1	Front Module Tension Body	1	0810-103F
2	Rigid Spring Locator	1	0801-10-S2L
3	Washer High Tensile 1 1/4"	1	0232-HT11-4
4	Module Tension Rod Assembly	1	0810-105A
5	Height Adjusting Chain Assembly 13 Link	1	0801-20MCA
6	Heavy Duty Coil Spring 24mm	1	0801-K2455350
7	Washer Flat M24	1	0231-F24

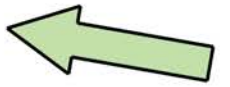

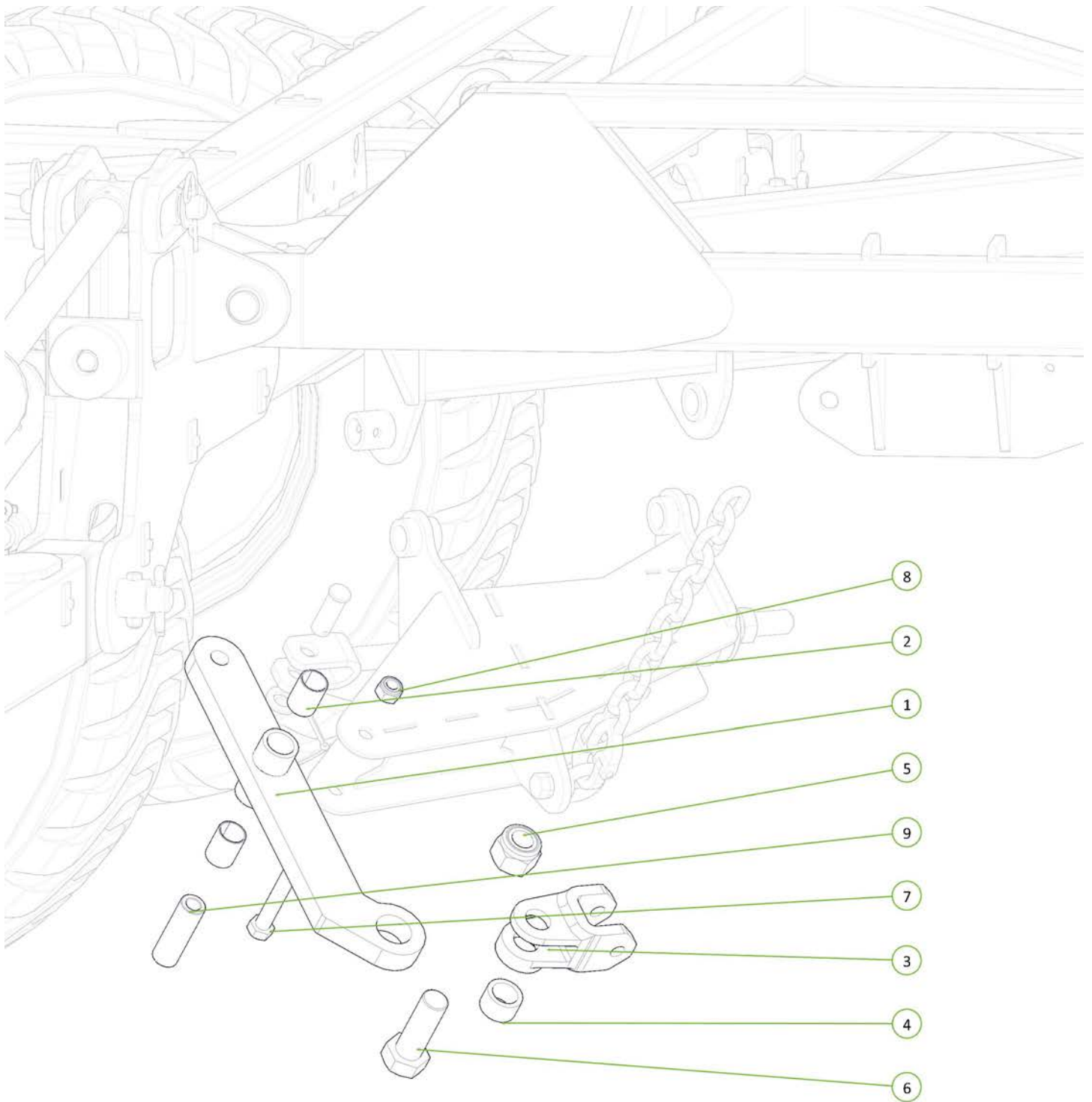

Item No.	Description	Qty	Number
1	Module Tension Arm	1	0810-104
2	35 ID x 50mm DU Bush	2	0113-MB 3550DU
3	Forged Clevis 21mm Bolt Hole	1	0801-FC21
4	Stainless Steel Wear Bush	1	1501-365033-SS
5	Nyloc Nut M36	1	0221-NYL36
6	M36 x 105 grade 8.8 zp Bolt	1	0211-36105
7	M20 x 150 grade 8.8 ZP Bolt	1	0211-20150
8	Nyloc Nut M20	1	0221-NYL20
9	Module Pivot Arm Bush	1	0801-10-110

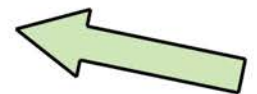



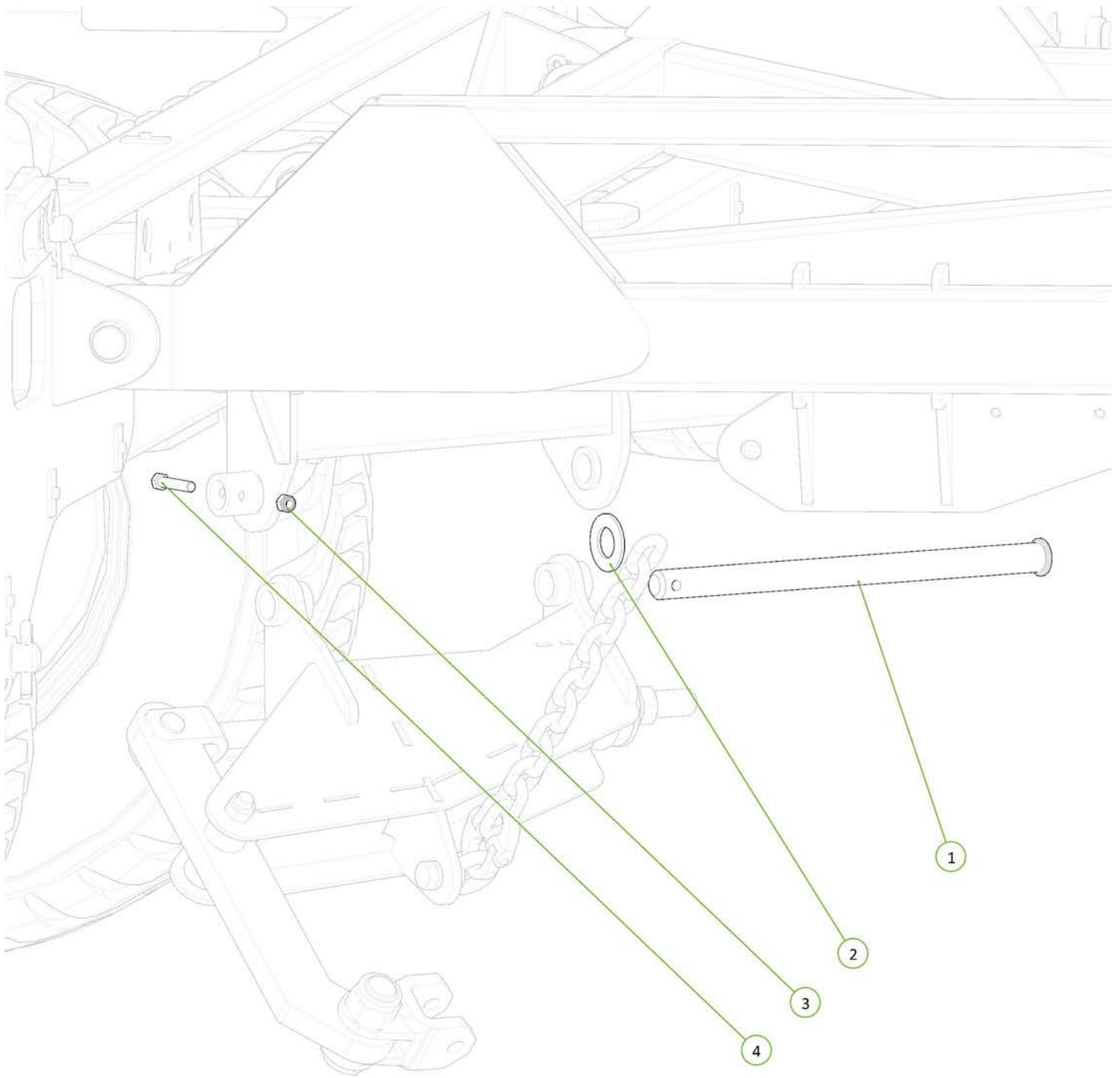

Item No.	Description	Qty	Number
1	Chain Mount Pivot Pin	1	0801-10-51
2	Washer High Tensile 1 3/8"	1	0232-HT13-8
3	Nyloc Nut M12	1	0221-NYL12
4	M12 x 65 grade 8.8 ZP Bolt	1	0211-1265

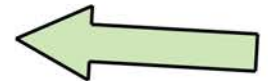

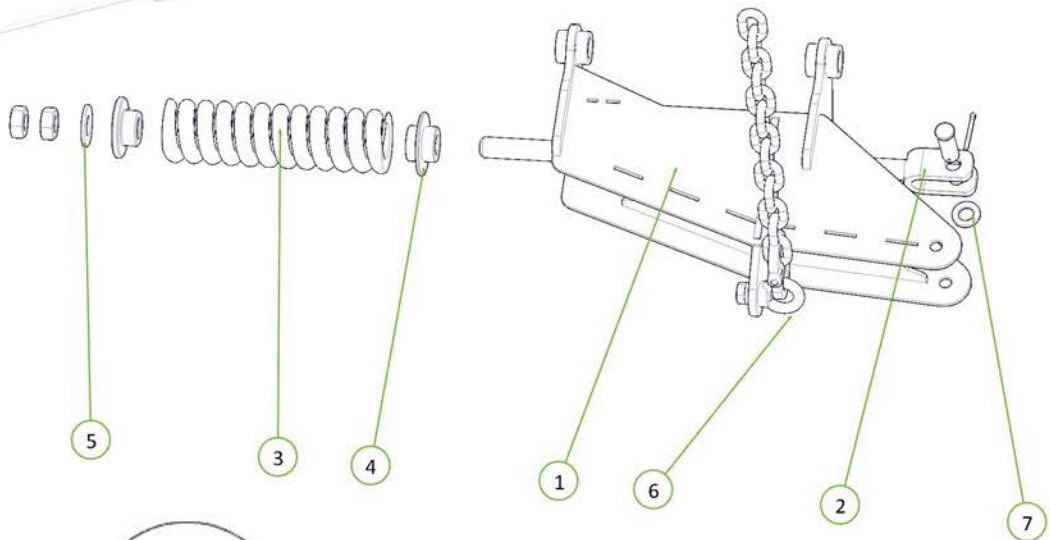
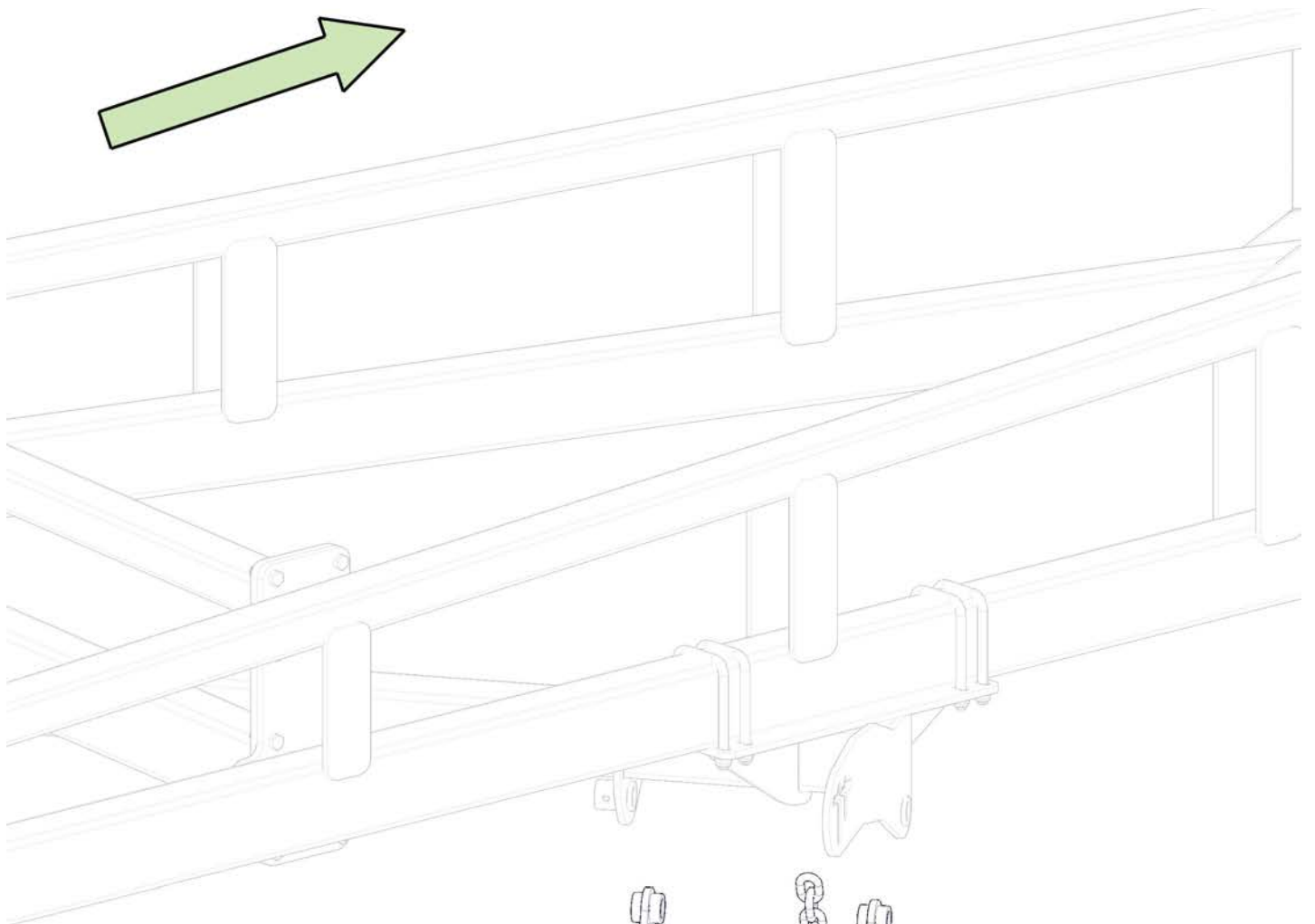

Item No.	Description	Qty	Number
1	Rear Module Tension Body	1	0810-103R
2	Module Tension Rod Assembly	1	0810-105
3	Heavy Duty Coil Spring 24mm	1	0801-K2455350
4	Rigid Spring Locator	1	0801-10-S2L
5	Washer High Tensile 1 1/4"	1	0232-HT11-4
6	Height Adjusting Chain Assembly 13 Link	1	0801-20MCA
7	Washer Flat M24	1	0231-F24

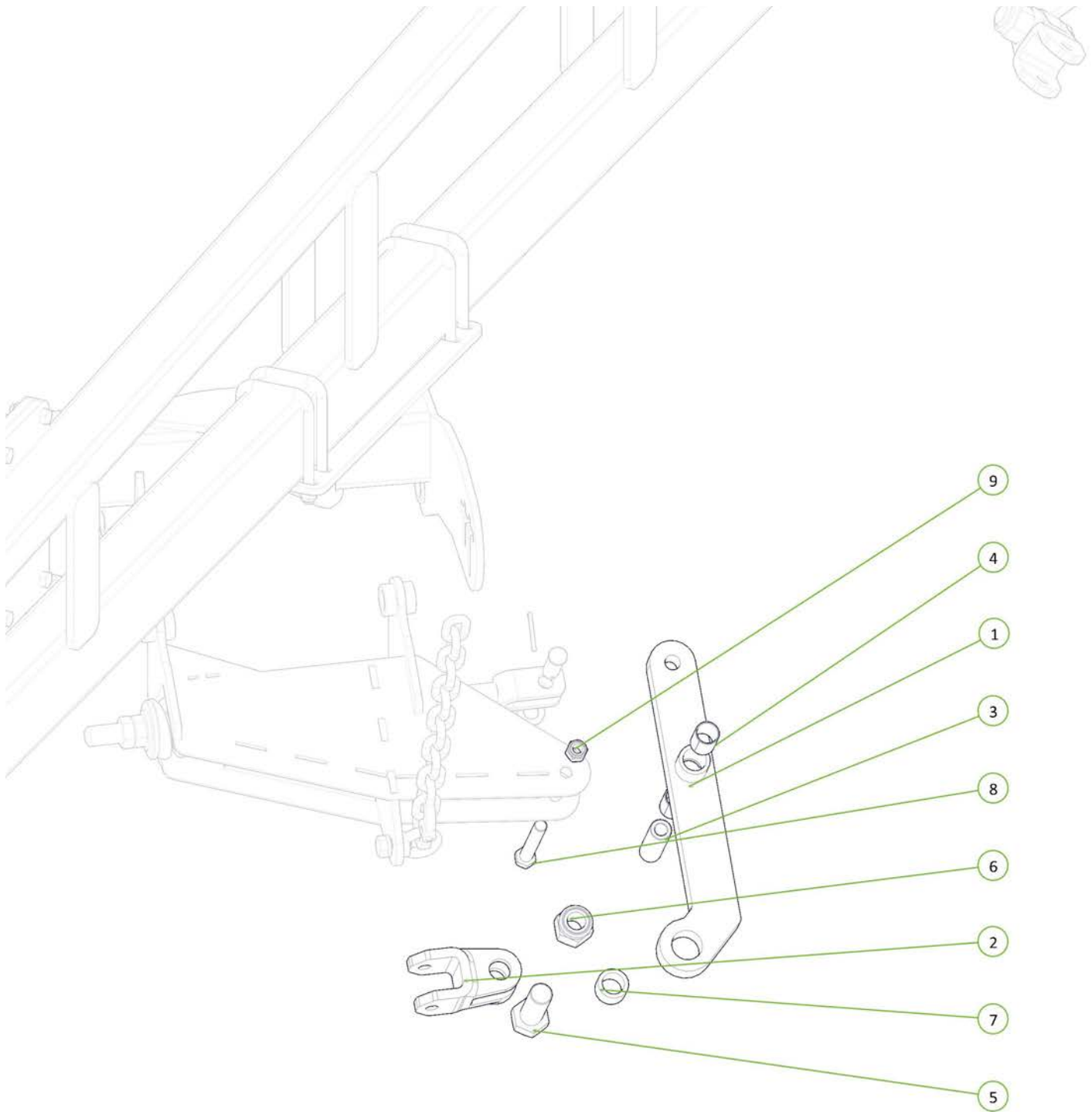

Item No.	Description	Qty	Number
1	Module Tension Arm	1	0810-104
2	Forged Clevis 21mm Bolt Hole	1	0801-FC21
3	Module Pivot Arm Bush	1	0801-10-110
4	35 ID x 50mm DU Bush	2	0113-MB 3550DU
5	M36 x 105 grade 8.8 zp Bolt	1	0211-36105
6	Nyloc Nut M36	1	0221-NYL36
7	Stainless Steel Wear Bush	1	1501-365033-SS
8	M20 x 150 grade 8.8 ZP Bolt	1	0211-20150
9	Nyloc Nut M20	1	0221-NYL20

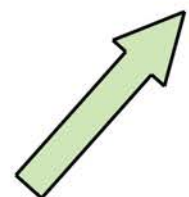

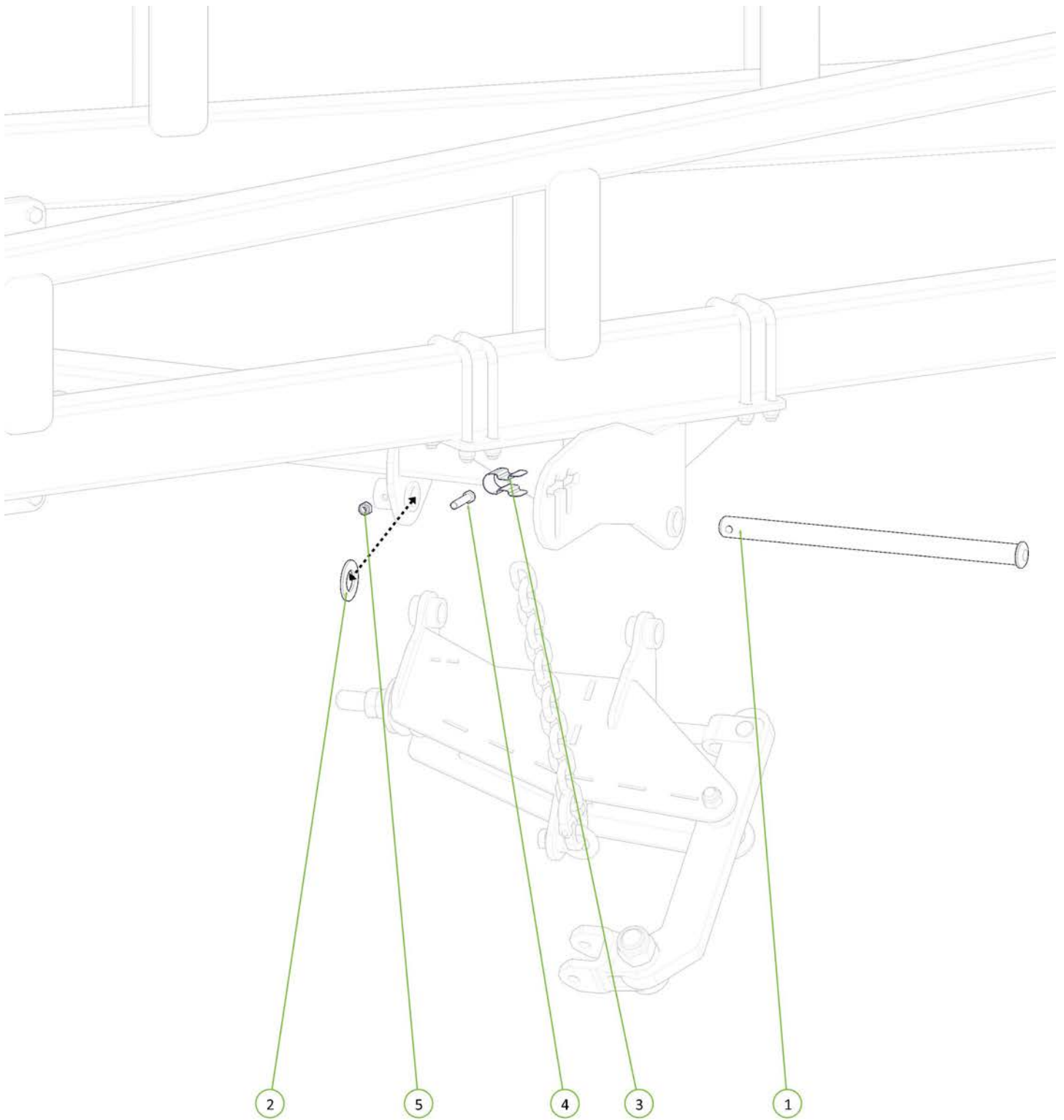

Item No.	Description	Qty	Number
1	Chain Mount Pivot Pin	1	0801-10-51
2	Washer High Tensile 1 3/8"	1	0232-HT13-8
3	Height Adjustor Retaining Clip	1	0801-KE014
4	M12 x 65 grade 8.8 ZP Bolt	1	0211-1265
5	Nyloc Nut M12	1	0221-NYL12

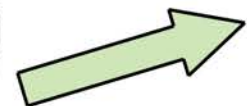

Item No.	Description	Qty	Number
1	Long Module Lift Arm	1	1610-106
2	Height Adjustor Retaining Clip	1	0801-KE014
3	Clevis Pin 25mm x 75mm	1	0801-KE0307-1
4	Cotter Pin M5 x 50	1	0261-PINC550
5	Washer Flat M24	1	0231-F24

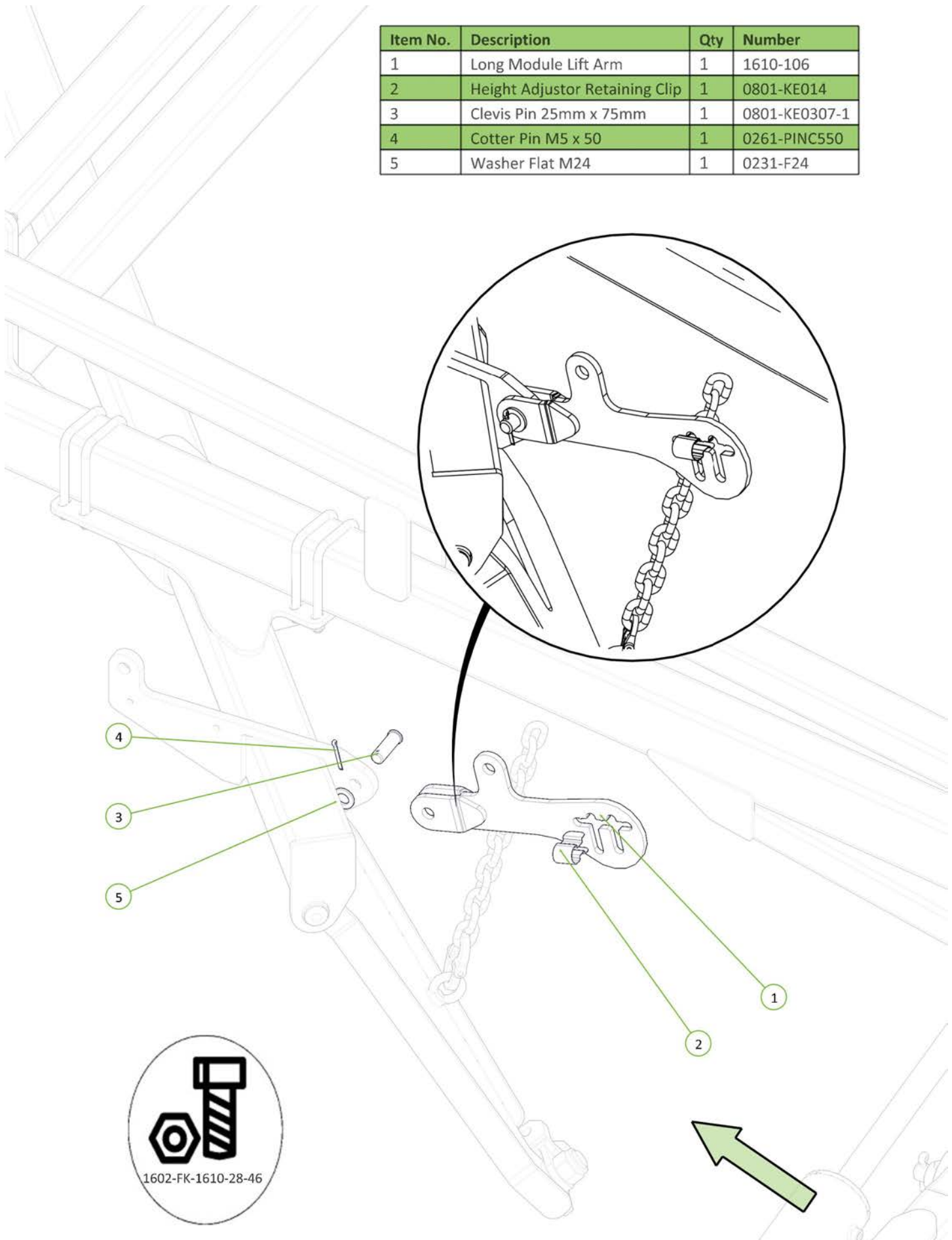

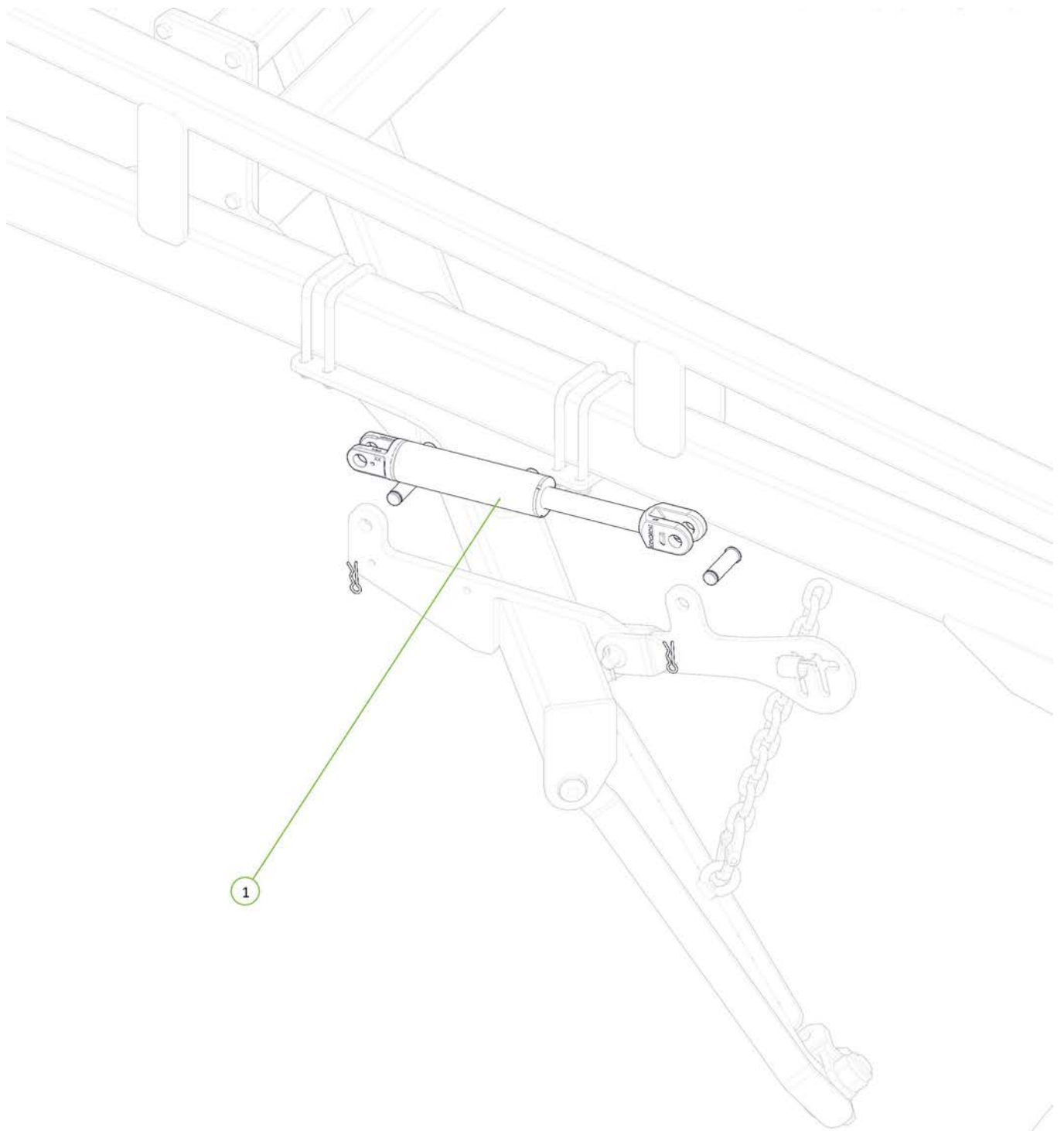

Item No.	Description	Qty	Number
1	2.5" Bore x 6" Stroke 1.5" Rod Side Port Cylinder	1	0311-256SP

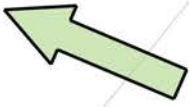

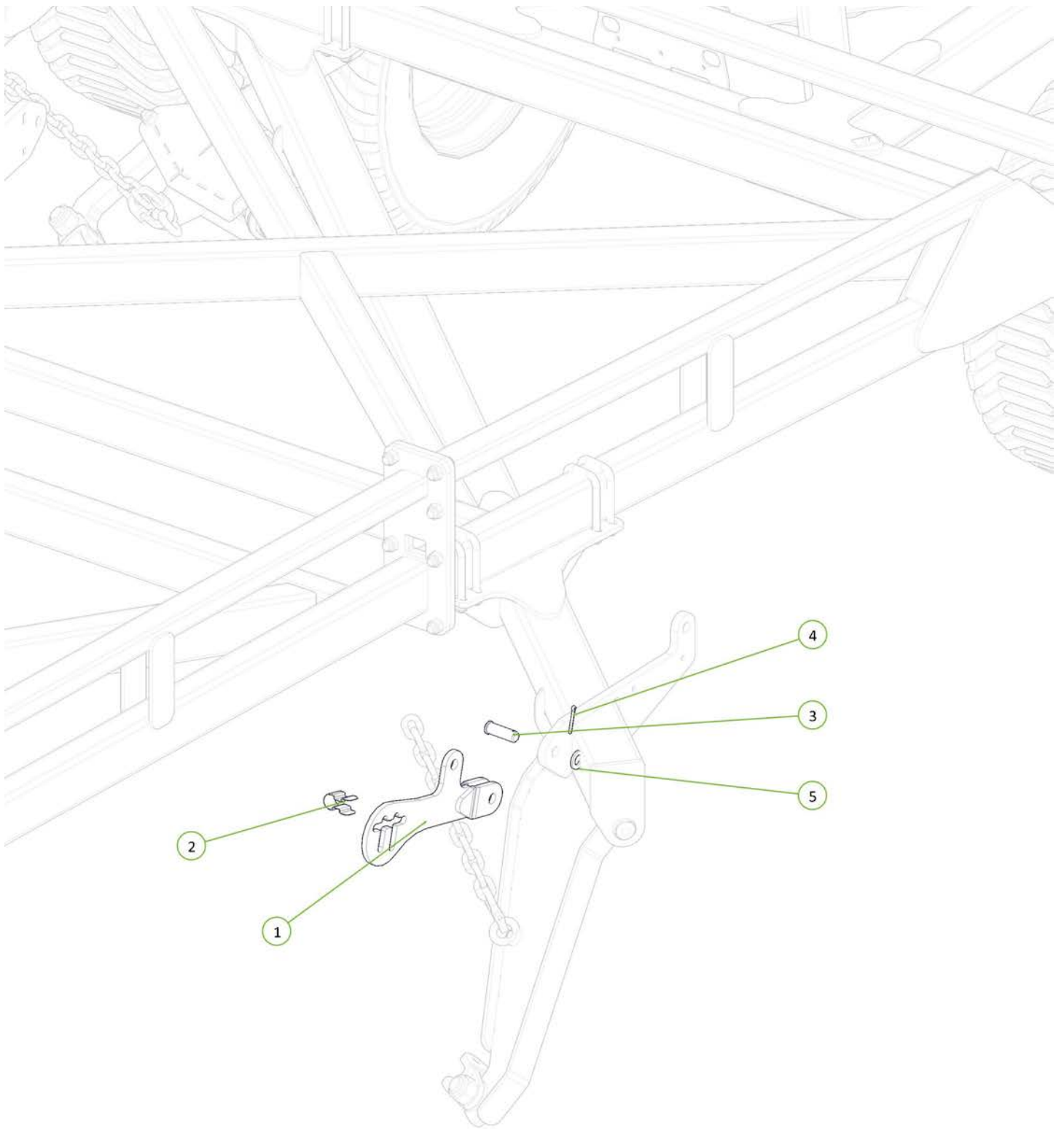

Item No.	Description	Qty	Number
1	Long Module Lift Arm	1	1610-106
2	Height Adjustor Retaining Clip	1	0801-KE014
3	Clevis Pin 25mm x 75mm	1	0801-KE0307-1
4	Cotter Pin M5 x 50	1	0261-PINC550
5	Washer Flat M24	1	0231-F24

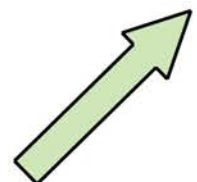

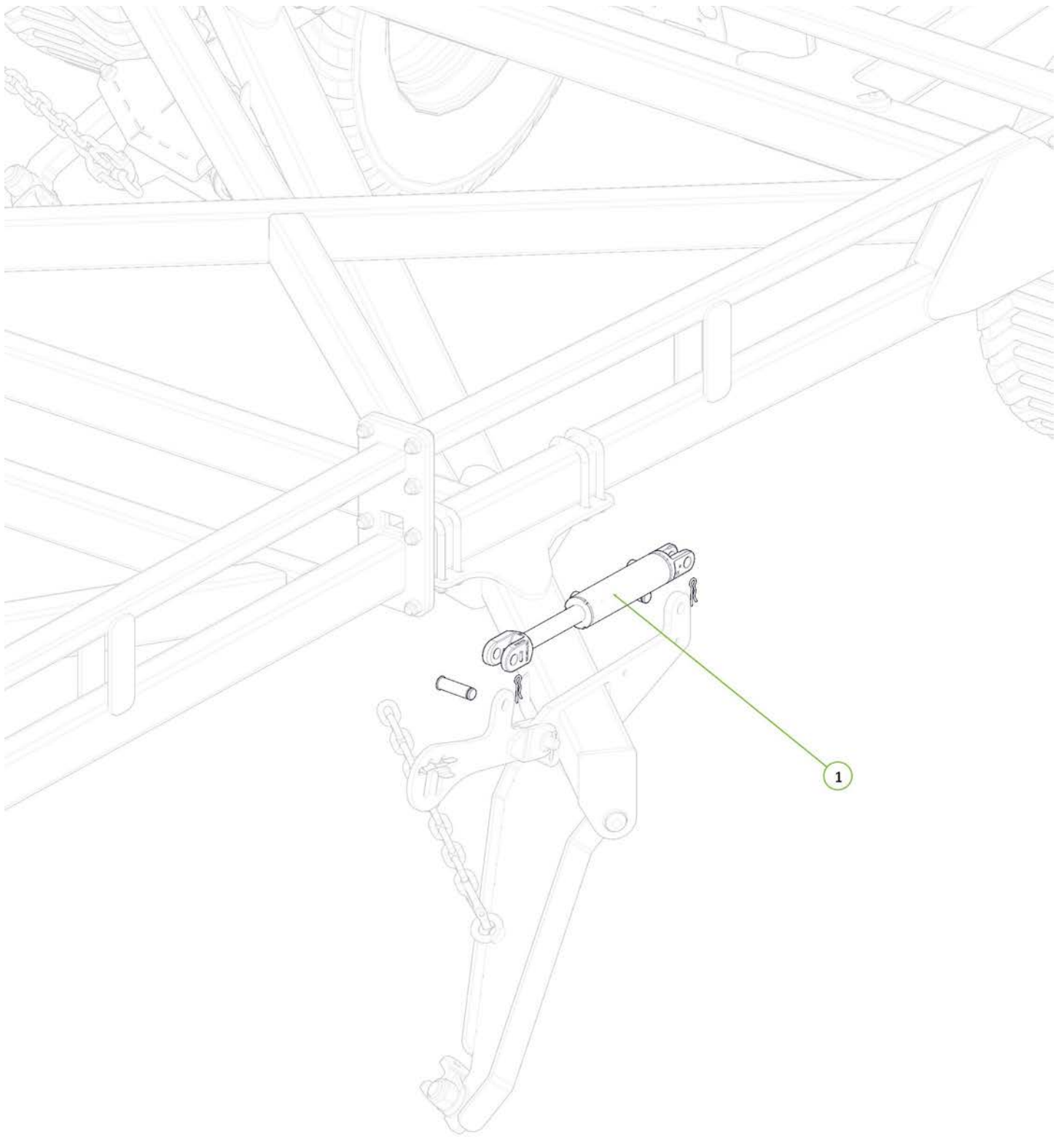

Item No.	Description	Qty	Number
1	2.5" Bore x 6" Stroke 1.5" Rod Side Port Cylinder	1	0311-256SP

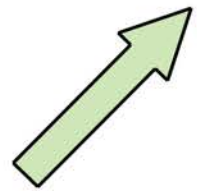



Item No.	Description	Qty	Number
1	Short Module Lift Arm	1	1610-107
2	Height Adjustor Retaining Clip	1	0801-KE014
3	Clevis Pin 25mm x 75mm	1	0801-KE0307-1
4	Cotter Pin M5 x 50	1	0261-PINC550
5	Washer Flat M24	1	0231-F24

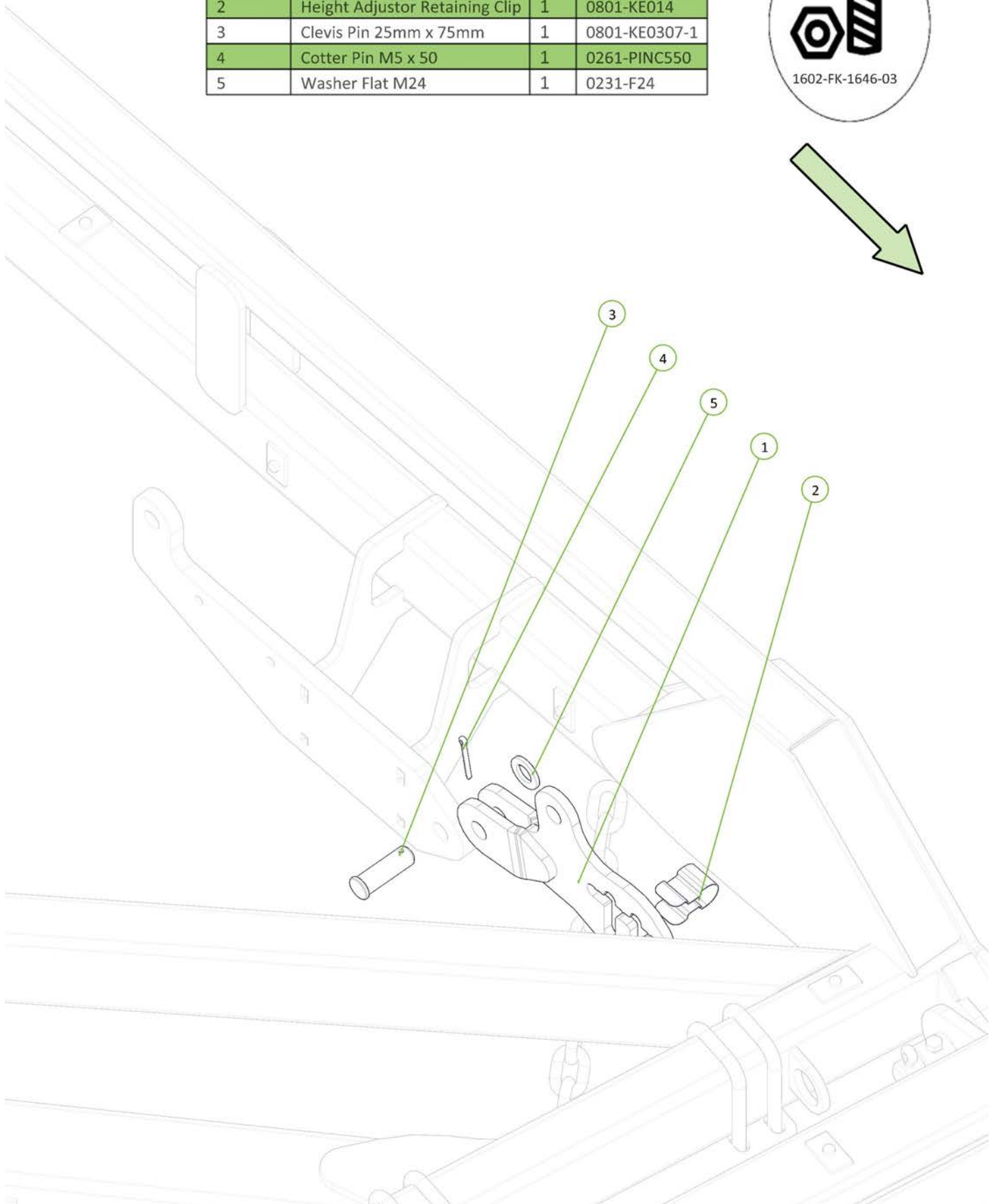
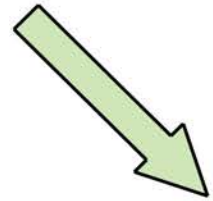

Item No.	Description	Qty	Number
1	2.5" Bore x 6" Stroke 1.5" Rod Side Port Cylinder	1	0311-256SP

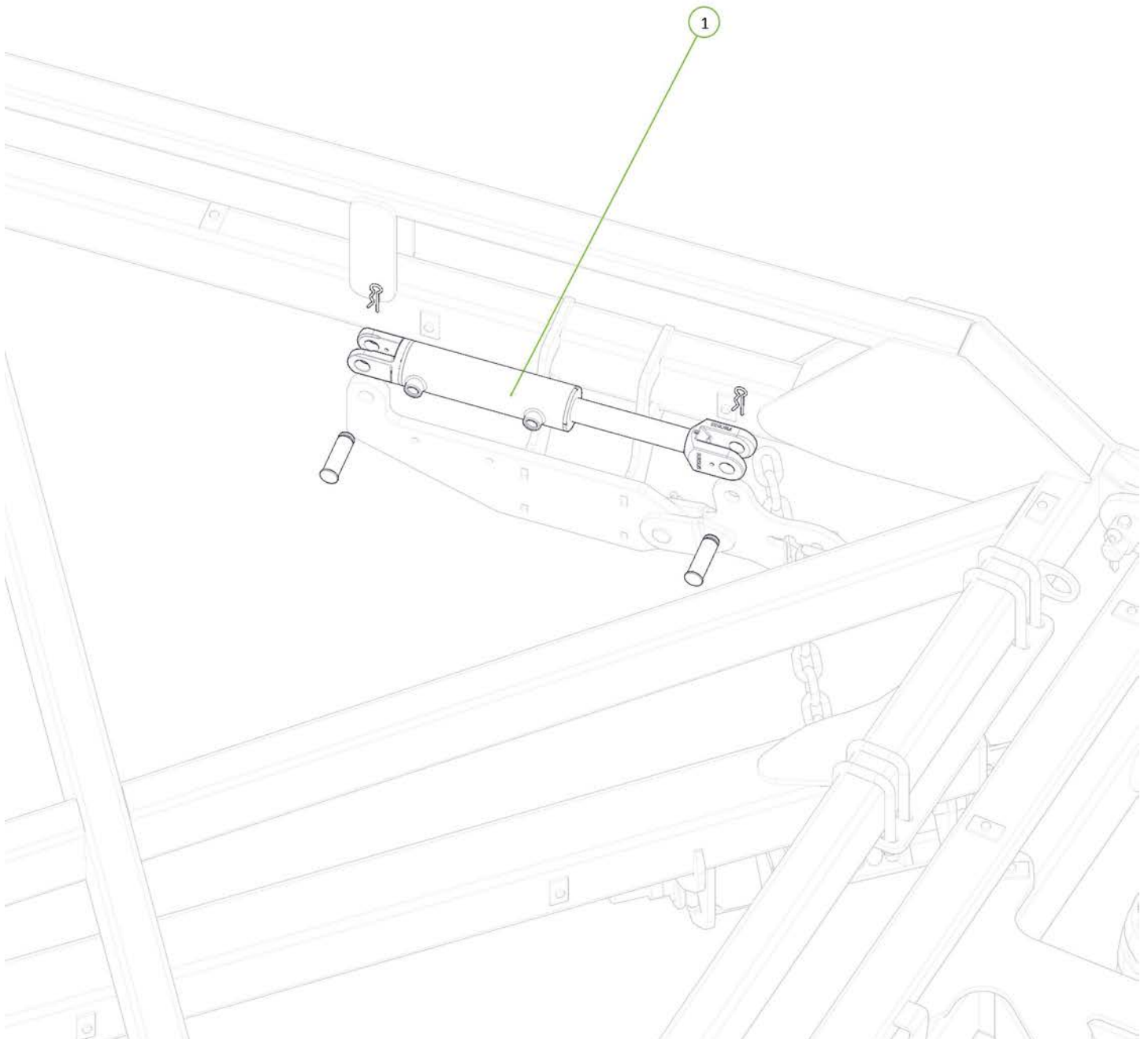
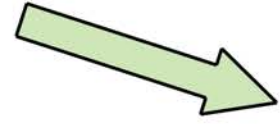

**Metric PN - 0271-16112104**

**Imperial PN - 0271-16114106U**

**Imperial Description - U-Bolt M16 x 114 Deep x 106 Wide**

**Metric PN - 0271-16160127**

**Imperial PN - 0271-16162129U**

**Imperial Description - U-Bolt M16 x 162 Deep x 129 Wide**



Item No.	Description	Qty	Number
1	45/46 Chain Carrier Beam	1	0810-17-45
2	Chain Carrier Mount Plate	1	0800-139.1
3	U-Bolt M16 x 112 Deep x 104 Wide	4	0271-16112104
4	U-Bolt M16 x 160 Deep x 127 Wide	4	0271-16160127
5	Nyloc Nut M16	16	0221-NYL16
6	Washer Flat M16	16	0231-F16

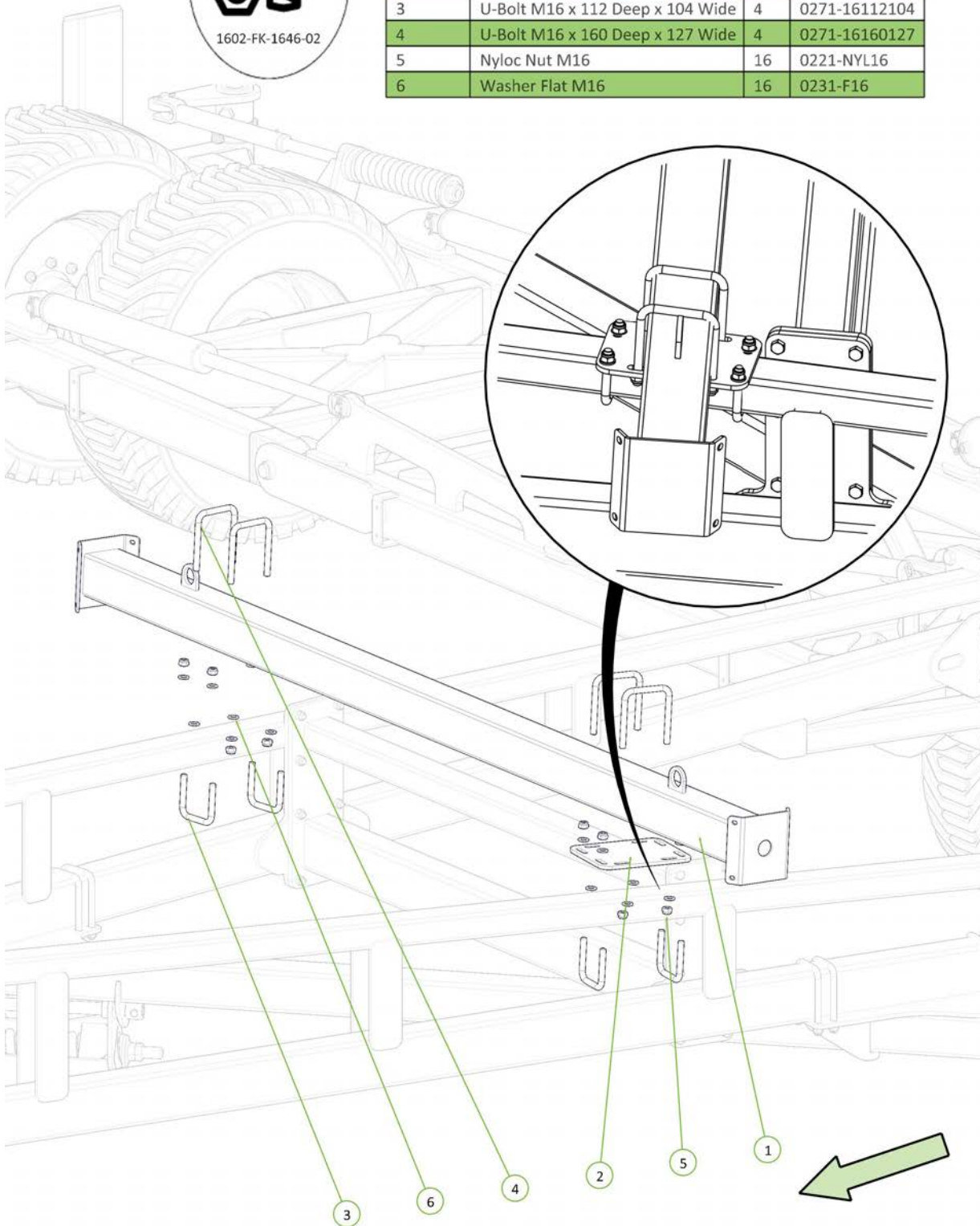

Item No.	Description	Qty	Number
1	Chain Carrier Bolt on End	2	0810-17L
2	M12 x 40 Coach Head Bolt	8	0215-CH1240
3	Nyloc Nut M12	8	0221-NYL12
4	Washer Flat M12	8	0231-F12

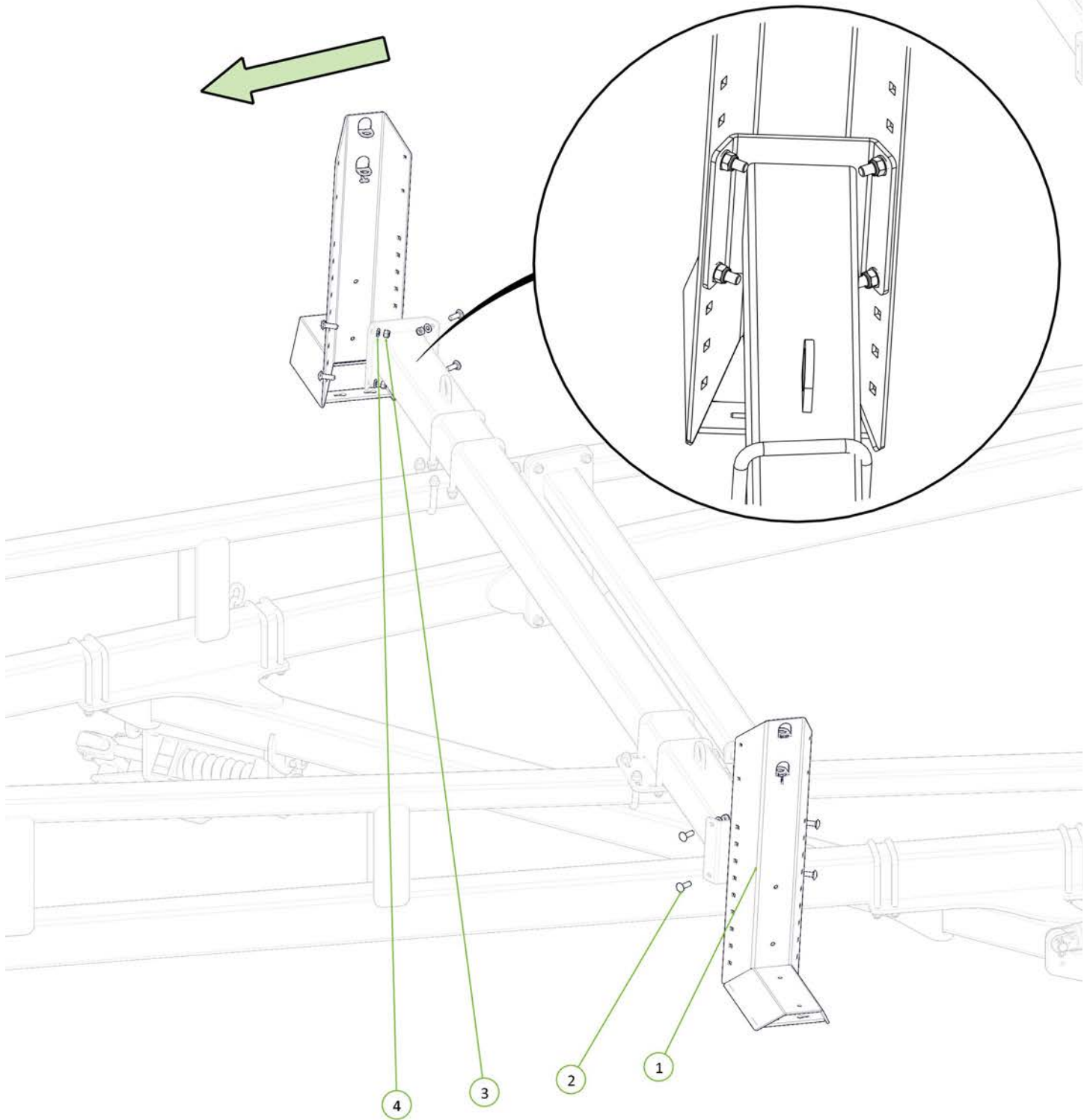

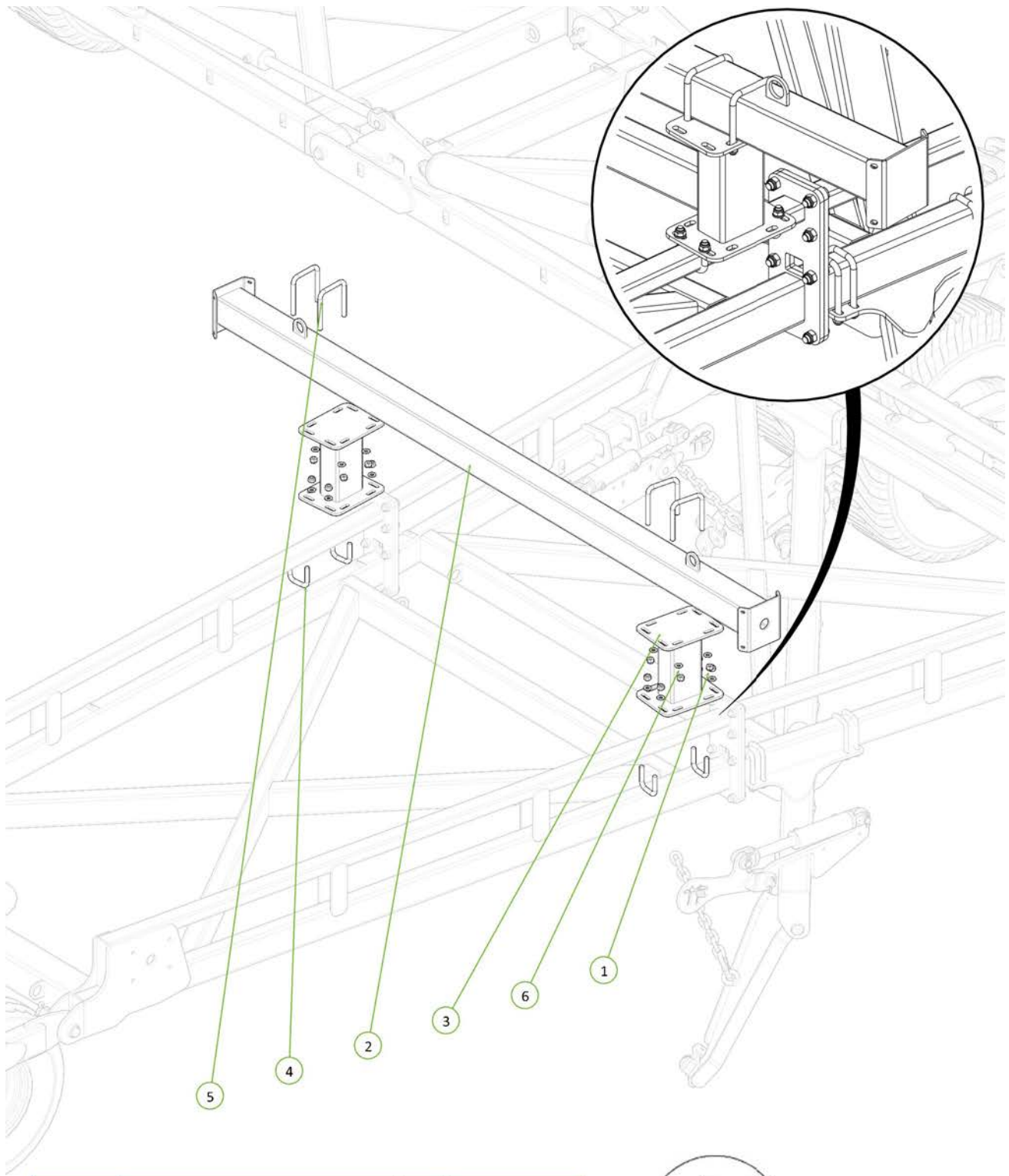

Item No.	Description	Qty	Number
1	Nyloc Nut M16	16	0221-NYL16
2	45/46 Chain Carrier Beam	1	0810-17-45
3	46' Chain Carrier Pedestal	2	1610-23
4	U-Bolt M16 x 85 Deep x 77 Wide	4	0271-168577
5	U-Bolt M16 x 160 Deep x 127 Wide	4	0271-16160127
6	Washer Flat M16	16	0231-F16

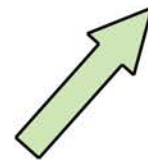

**Metric PN - 0271-168577**

**Imperial PN - 0271-168779U**

**Imperial Description - U-Bolt M16 x 87 Deep x 79 Wide**

**Metric PN - 0271-16160127**

**Imperial PN - 0271-16162129U**

**Imperial Description - U-Bolt M16 x 162 Deep x 129 Wide**

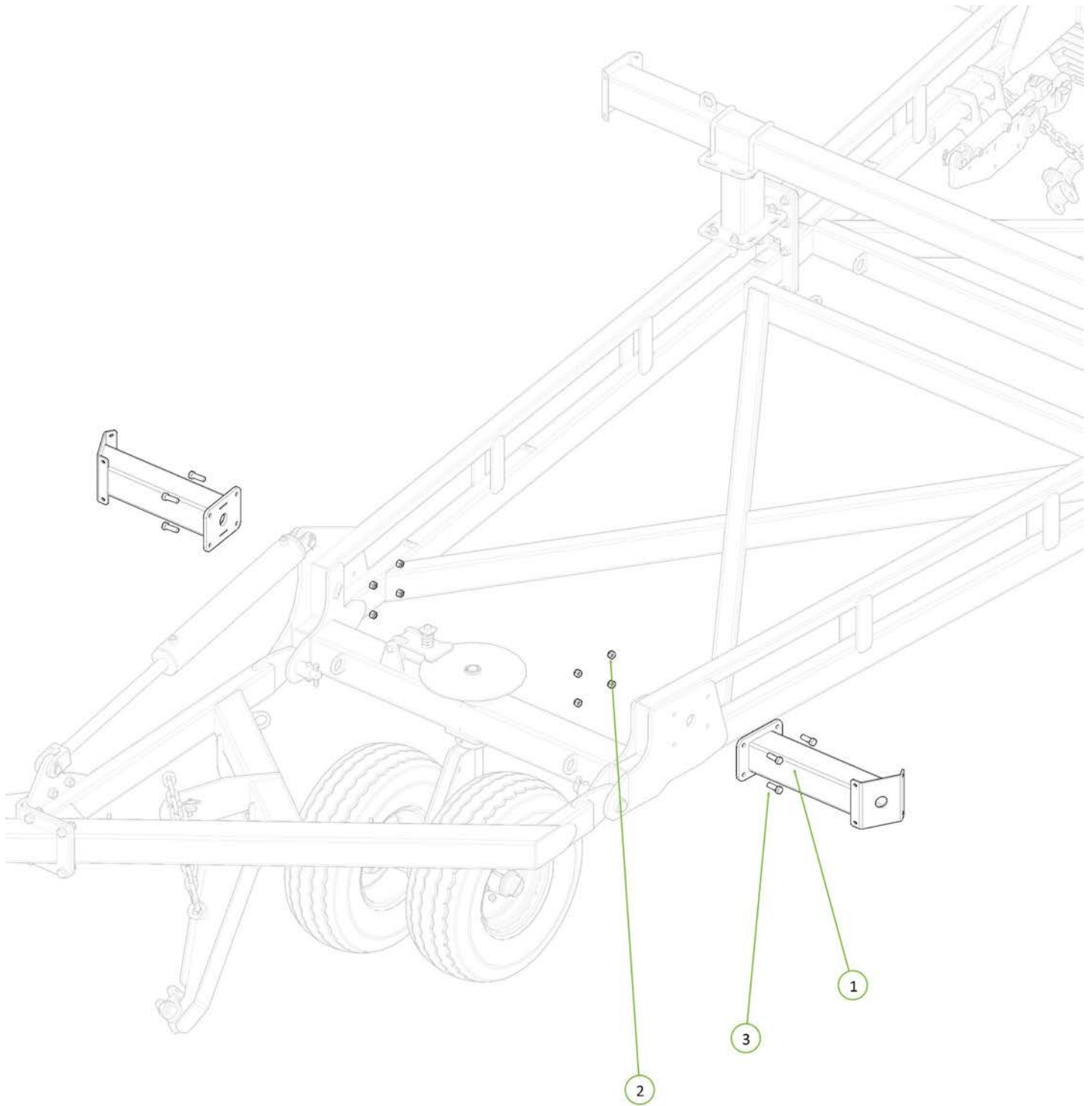

Item No.	Description	Qty	Number
1	46 Outrigger	2	1610-109
2	Nyloc Nut M16	8	0221-NYL16
3	M16 x 50 grade 8.8 zp Bolt	8	0211-1650



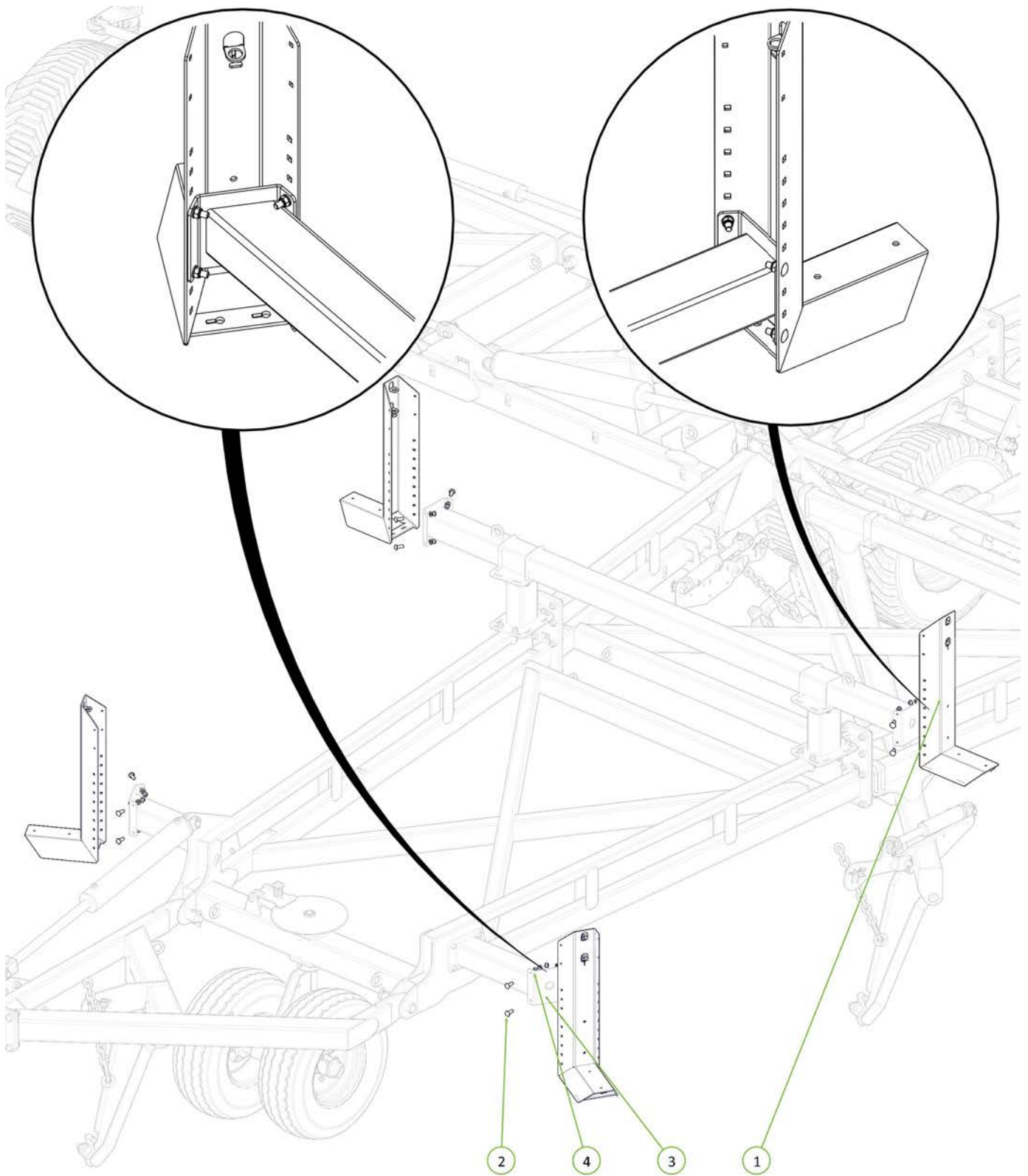

Item No.	Description	Qty	Number
1	Chain Carrier Bolt on End	4	0810-17L
2	M12 x 40 Coach Head Bolt	16	0215-CH1240
3	Nyloc Nut M12	16	0221-NYL12
4	Washer Flat M12	16	0231-F12

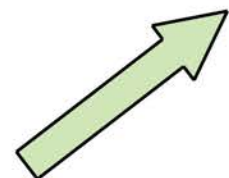

Item No.	Description	Qty	Number
1	Right Hand Off Set M	1	0810-18R
2	U-Bolt M12 x 105 Deep x 104 Wide	4	0271-12105104
3	Left Hand Off Set M	1	0810-19L
4	Round Tube Insert 60.3 x 3.2-5mm	4	0264-RTRi-5584
5	Nyloc Nut M12	8	0221-NYL12
6	Washer Flat M12	8	0231-F12



**Metric PN - 0271-12105104**

**Imperial PN - 0271-12107106U**

**Imperial Description - U-Bolt M12 x 107 Deep x 106 Wide**

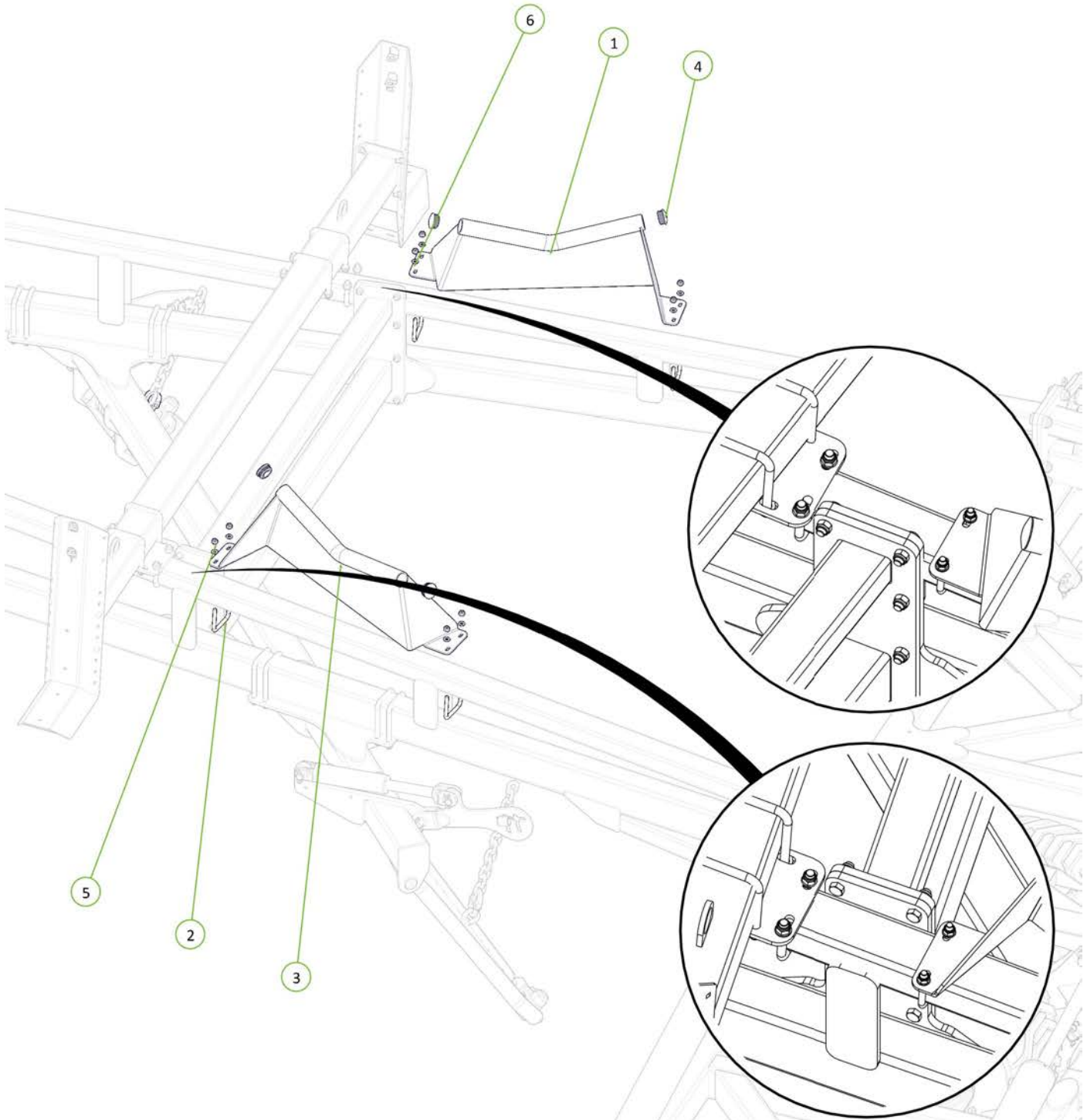



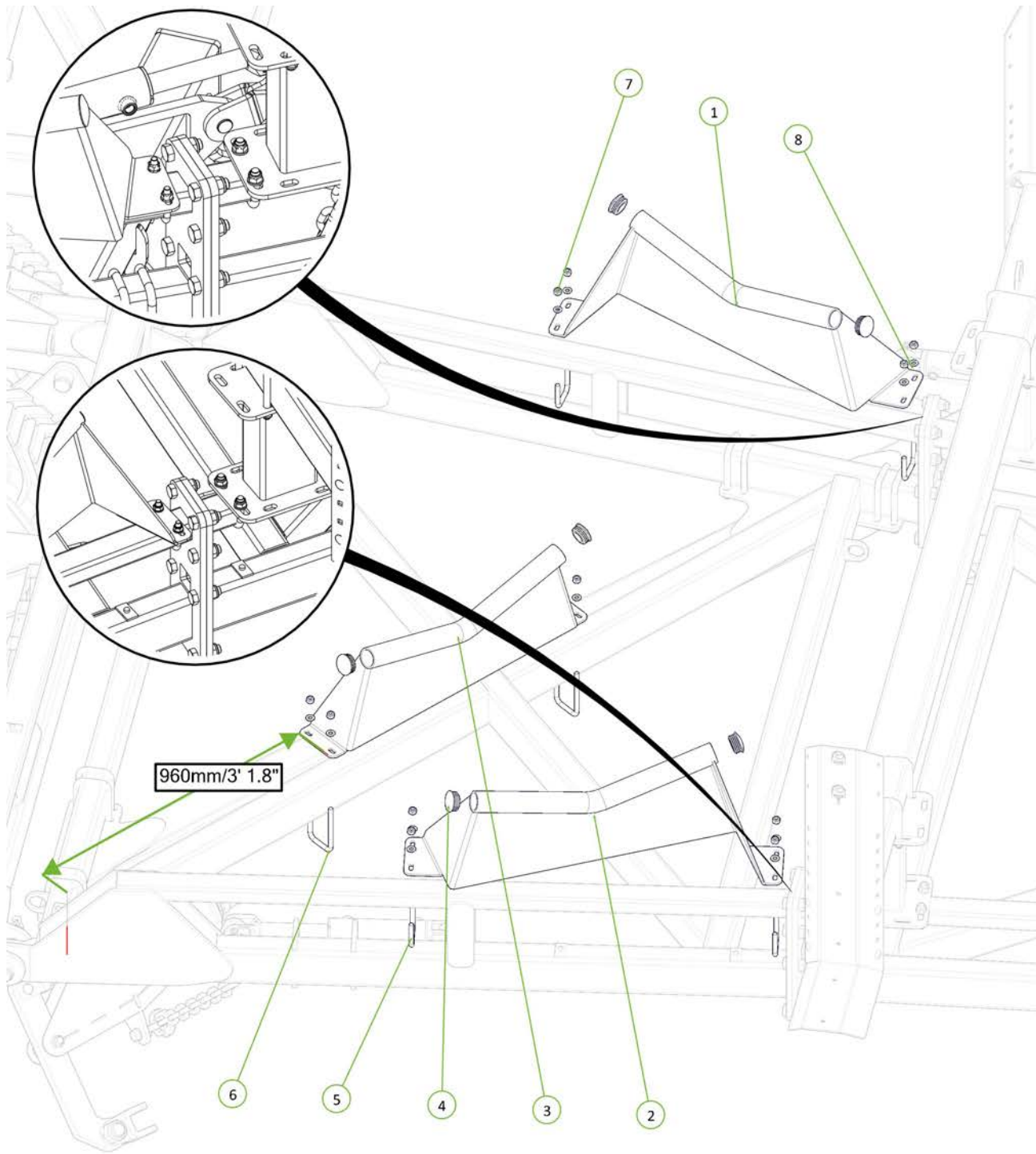

Item No.	Description	Qty	Number
1	Left Hand Off Set M	1	0810-19L
2	Right Hand Off Set M	1	0810-18R
3	Rear M	1	0810-19
4	Round Tube Insert 60.3 x 3.2-5mm	6	0264-RTRi-5584
5	U-Bolt M12 x 80 Deep x 77 Wide	4	0271-128077
6	U-Bolt M12 x 155 Deep x 77 Wide	2	0271-1215577
7	Nyloc Nut M12	12	0221-NYL12
8	Washer Flat M12	12	0231-F12



**Metric PN - 0271-128077**

**Imperial PN - 0271-128279U**

**Imperial Description - U-Bolt M12 x 82 Deep x 79 Wide**

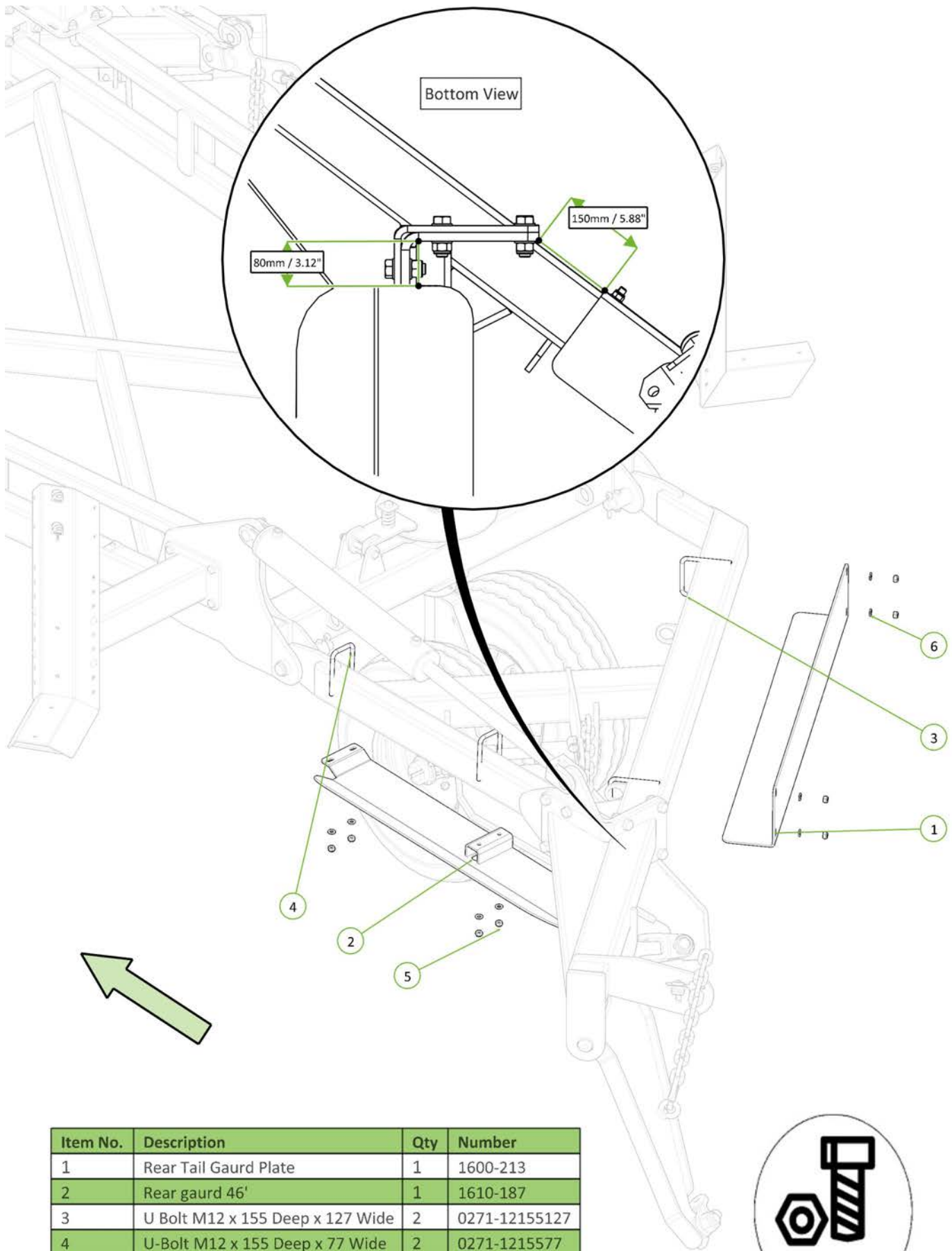

Item No.	Description	Qty	Number
1	Rear Tail Gaurd Plate	1	1600-213
2	Rear gaurd 46'	1	1610-187
3	U Bolt M12 x 155 Deep x 127 Wide	2	0271-12155127
4	U-Bolt M12 x 155 Deep x 77 Wide	2	0271-1215577
5	Nyloc Nut M12	8	0221-NYL12
6	Washer Flat M12	8	0231-F12



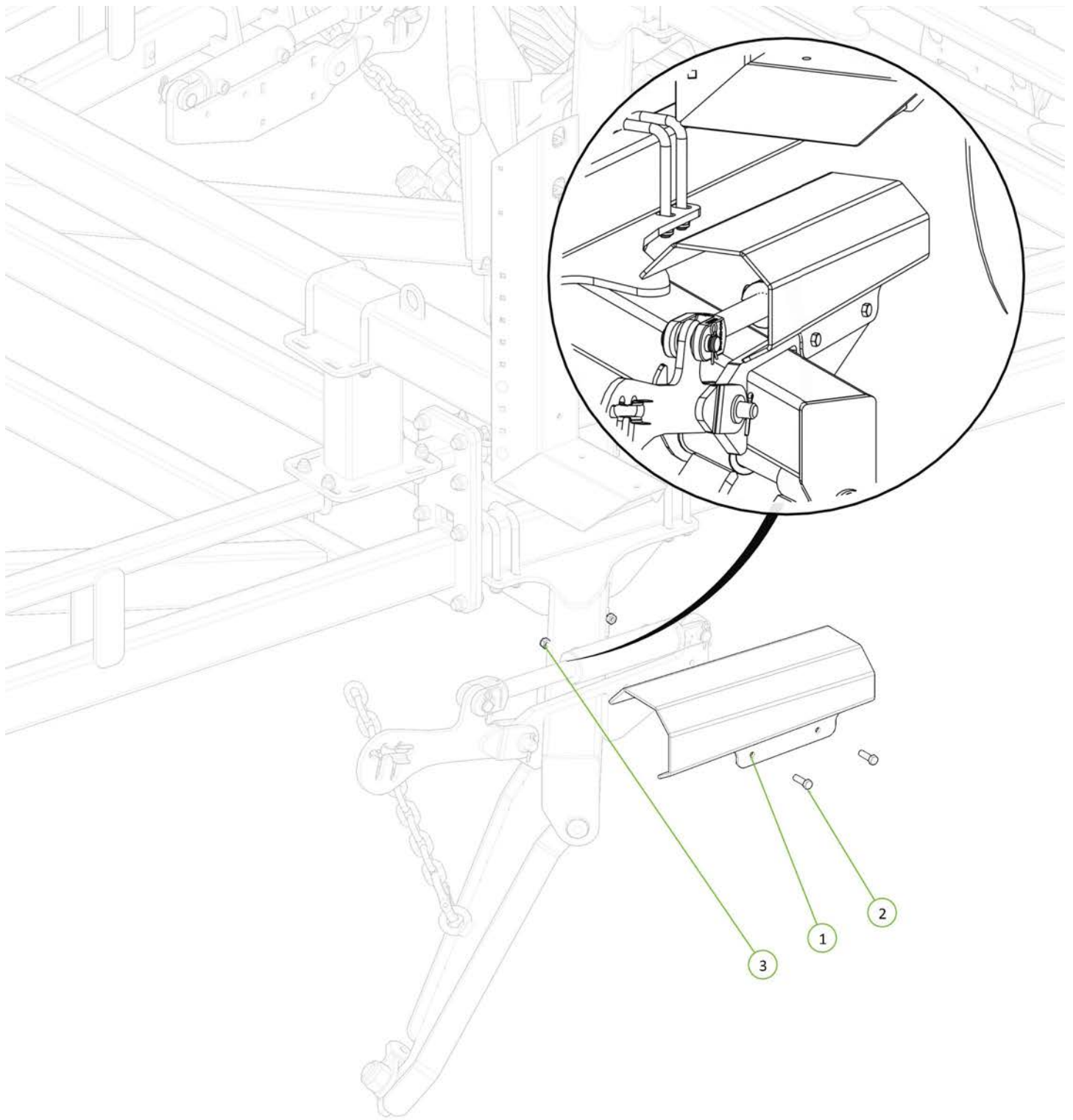

Item No.	Description	Qty	Number
1	Module Cylinder Guard	1	0800-167.3
2	M12 x 40 grade 8.8 ZP Bolt	2	0211-1240
3	Nyloc Nut M12	2	0221-NYL12

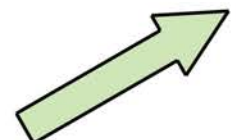

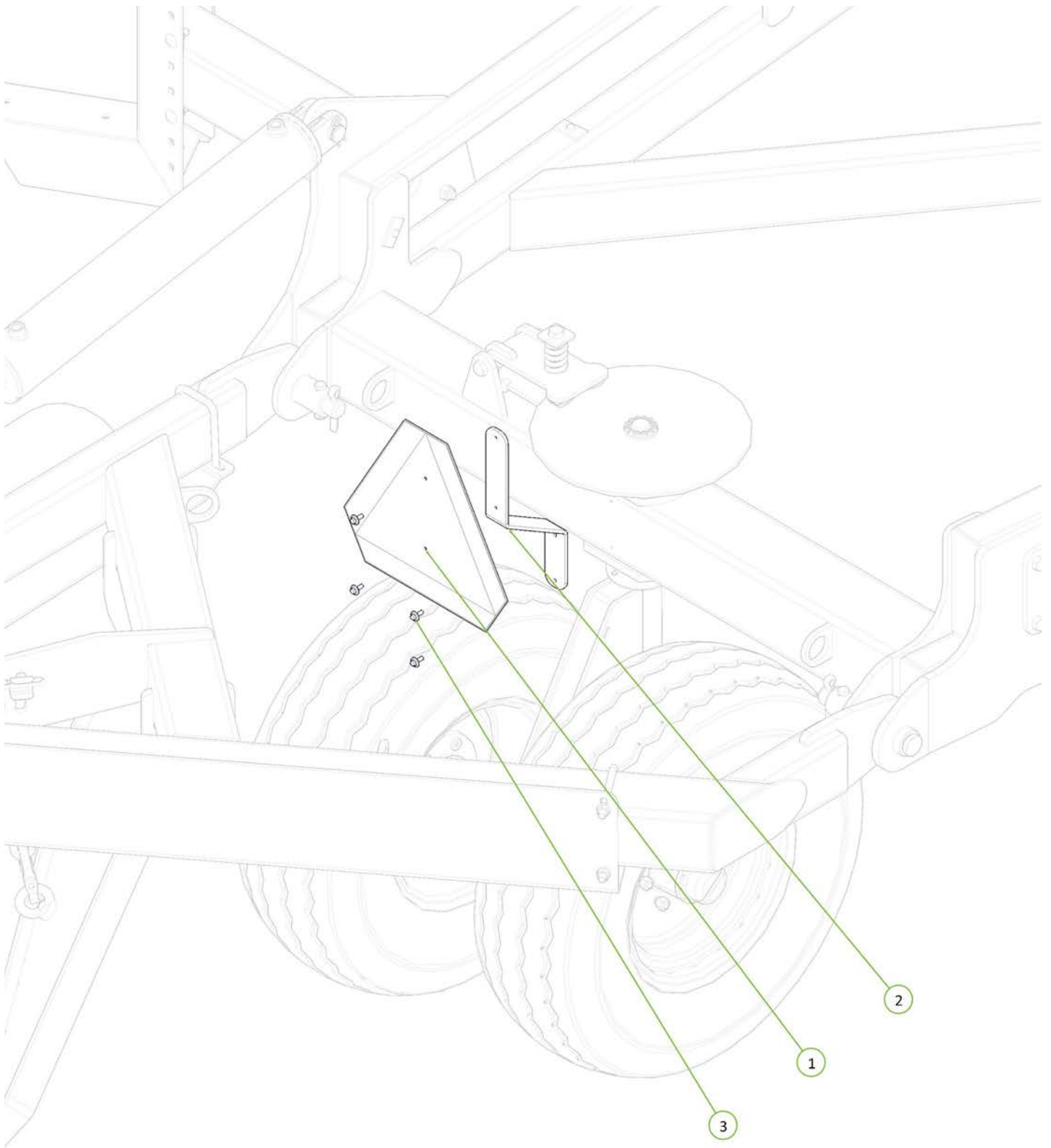

Item No.	Description	Qty	Number
1	Slow Moving Vehical Sign	1	0801-FBSMVTUF
2	SMV Sign Bracket - Fold	1	0800-195.1
3	M6 x 20 Trilobe self tapping Scew	4	0211-M620MZPHTF

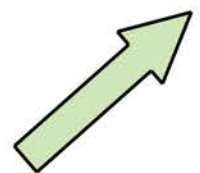

Item No.	Description	Qty	Number
1	Operator Manual Cannister	1	0801-OMC-1
2	M8 x 25 grade 8.8 ZP Bolt	3	0211-825
3	Nyloc Nut M8	3	0221-NYL8
4	Gear Wrench 1 3/4"	1	0802-GW1 3-4
5	Washer Flat M8	6	0231-F8

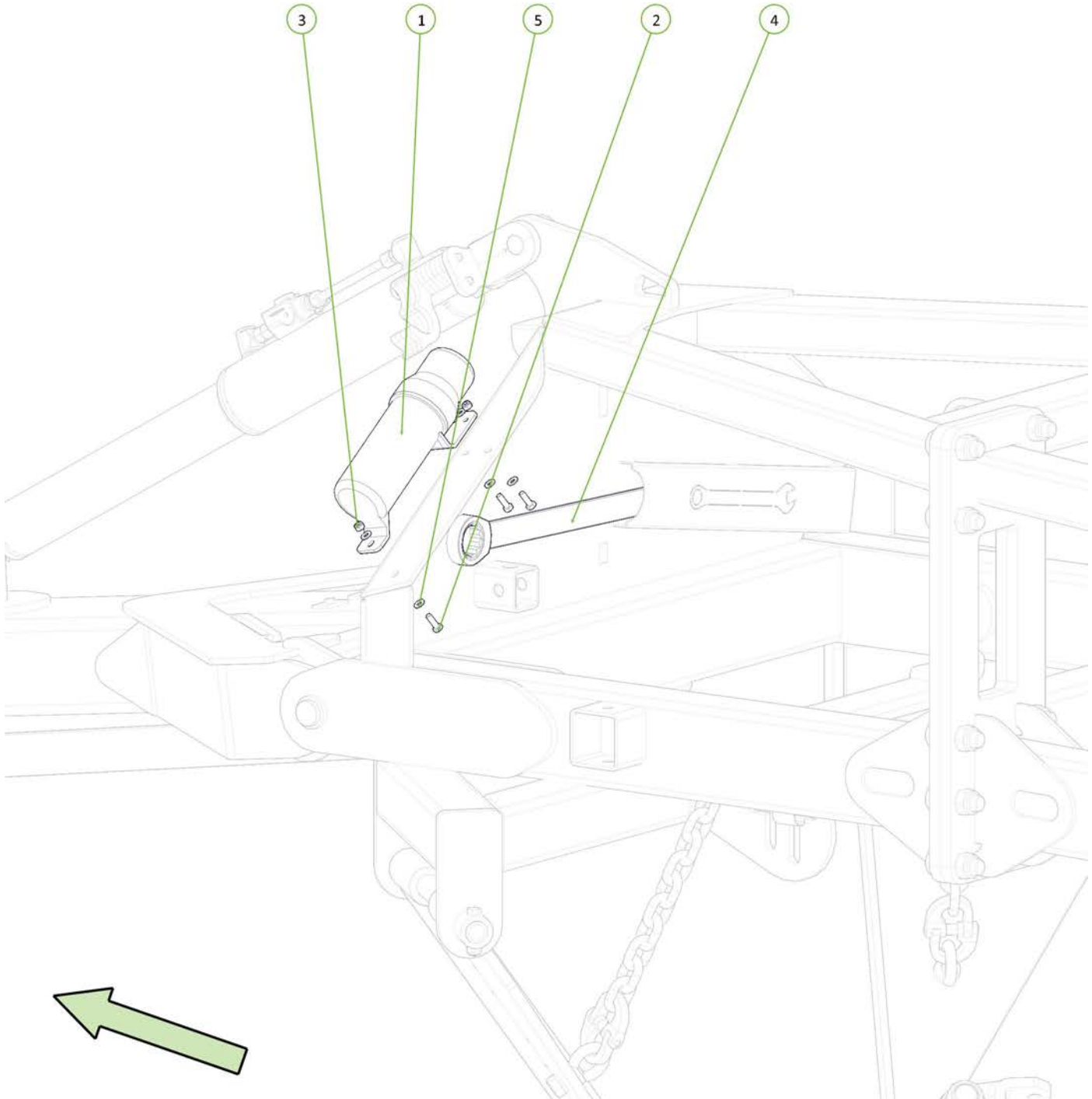

Item No.	Description	Qty	Number
1	Heavy Duty Jack Assembly	1	0810-37A
2	20mm Bolt Swivel Unit	1	0802-PCHB55
3	M20 x 110 grade 10.9 ZP Short Thread Bolt	1	0211-20110 ST
4	Nyloc Nut M20	1	0221-NYL20

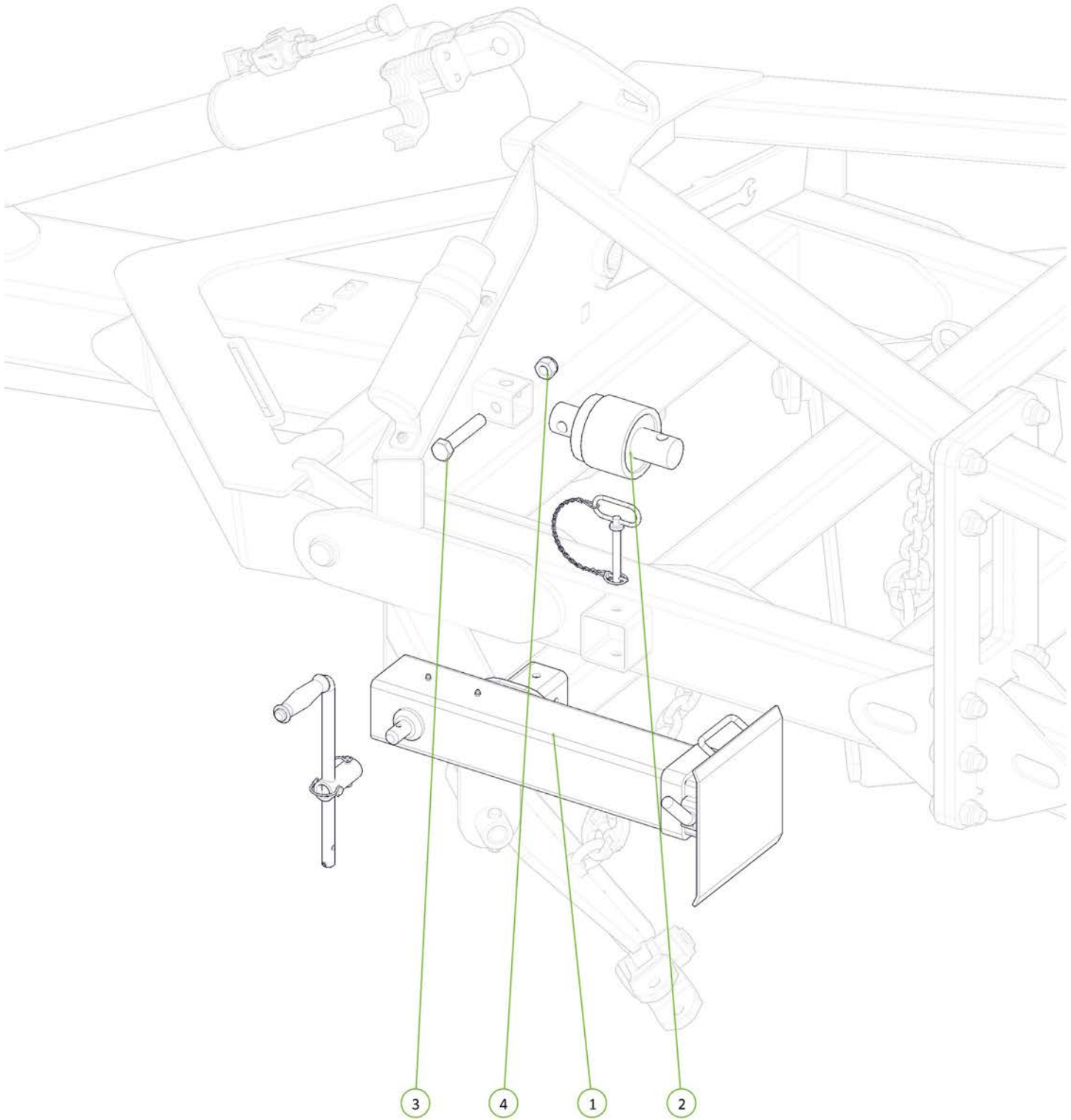

Item No.	Description	Qty	Number
1	Safety Chain Assembly	1	0810-16
2	Cylinder Safety Stop	1	0800-212.1
3	Square Loop Pin M8 x 63	1	0511-PINLOOPSQ863



Cylinder safety stop is placed over darwbar cylinder rod during transport to prevent accidental lowering.

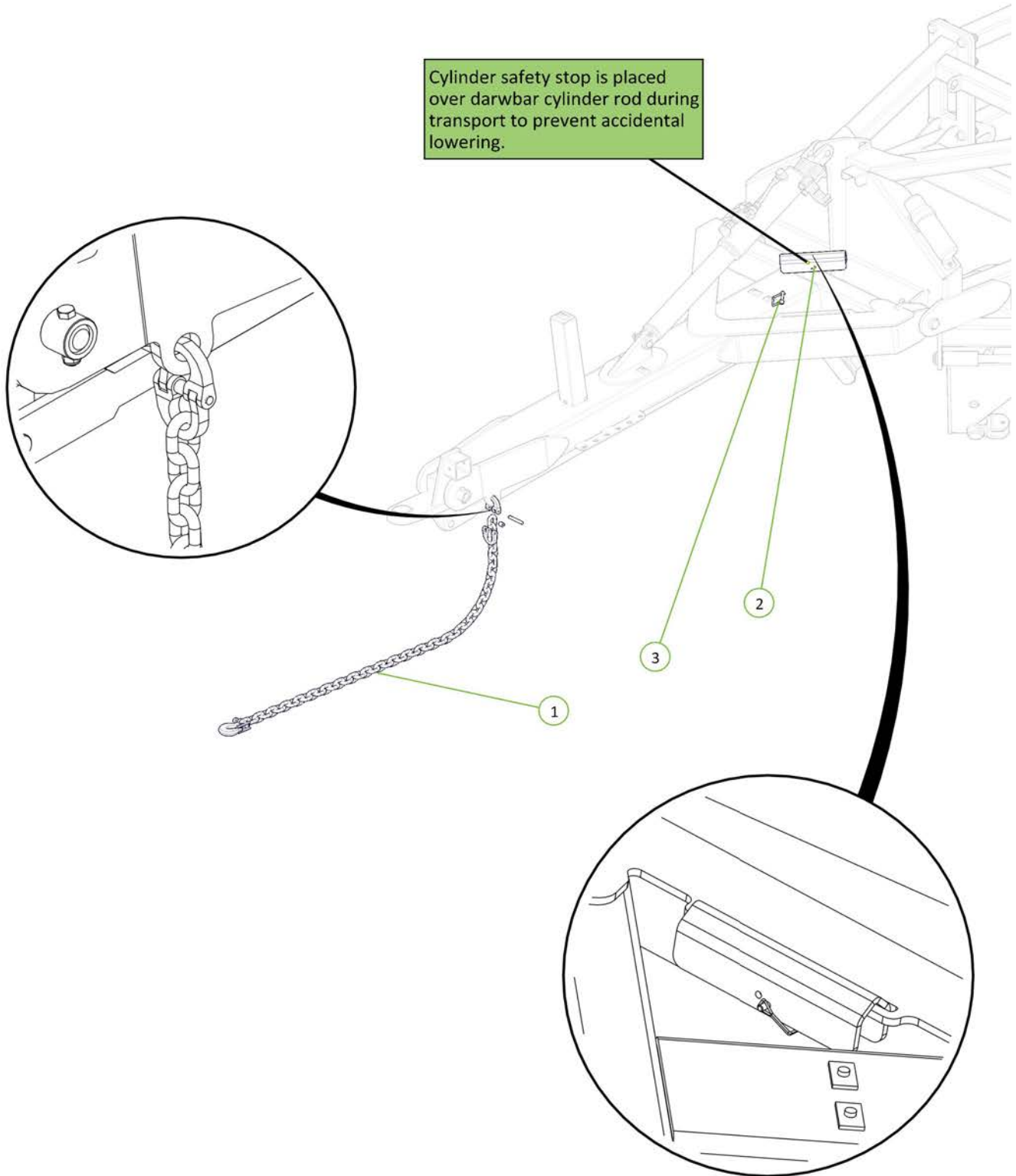

Item No.	Description	Qty	Number
1	20mm Bolt Swivel Unit	1	0802-PCHB55
2	Disc Chain Tie Plate Link 20mm	1	0802-DCTP-20
3	Tie Plate Bush	1	0801-PCDCS55
4	M20 x 110 grade 10.9 ZP Short Thread Bolt	3	0211-20110 ST
5	Nyloc Nut M20	3	0221-NYL20

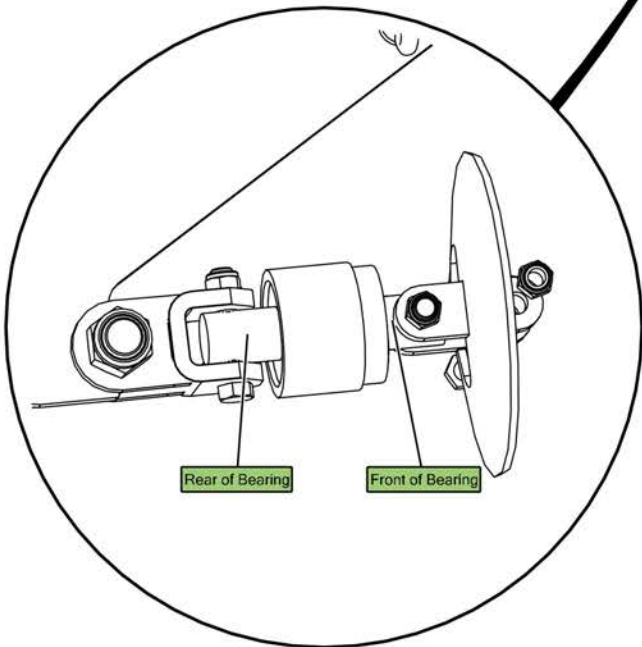
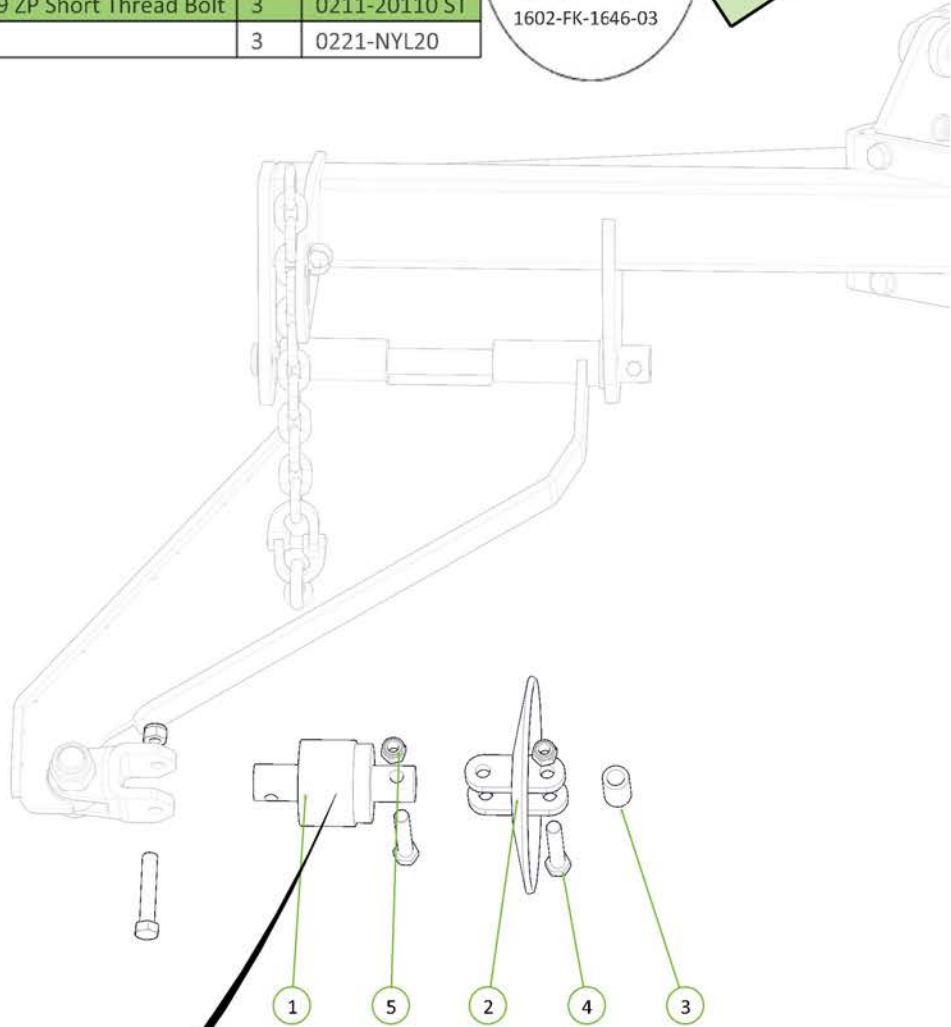
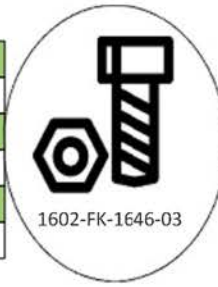

Ensure rear of bearing faces the rear of the machine, this prevents dirt being driven past the seals behind the disc welded to the shaft at the rear of the bearing.



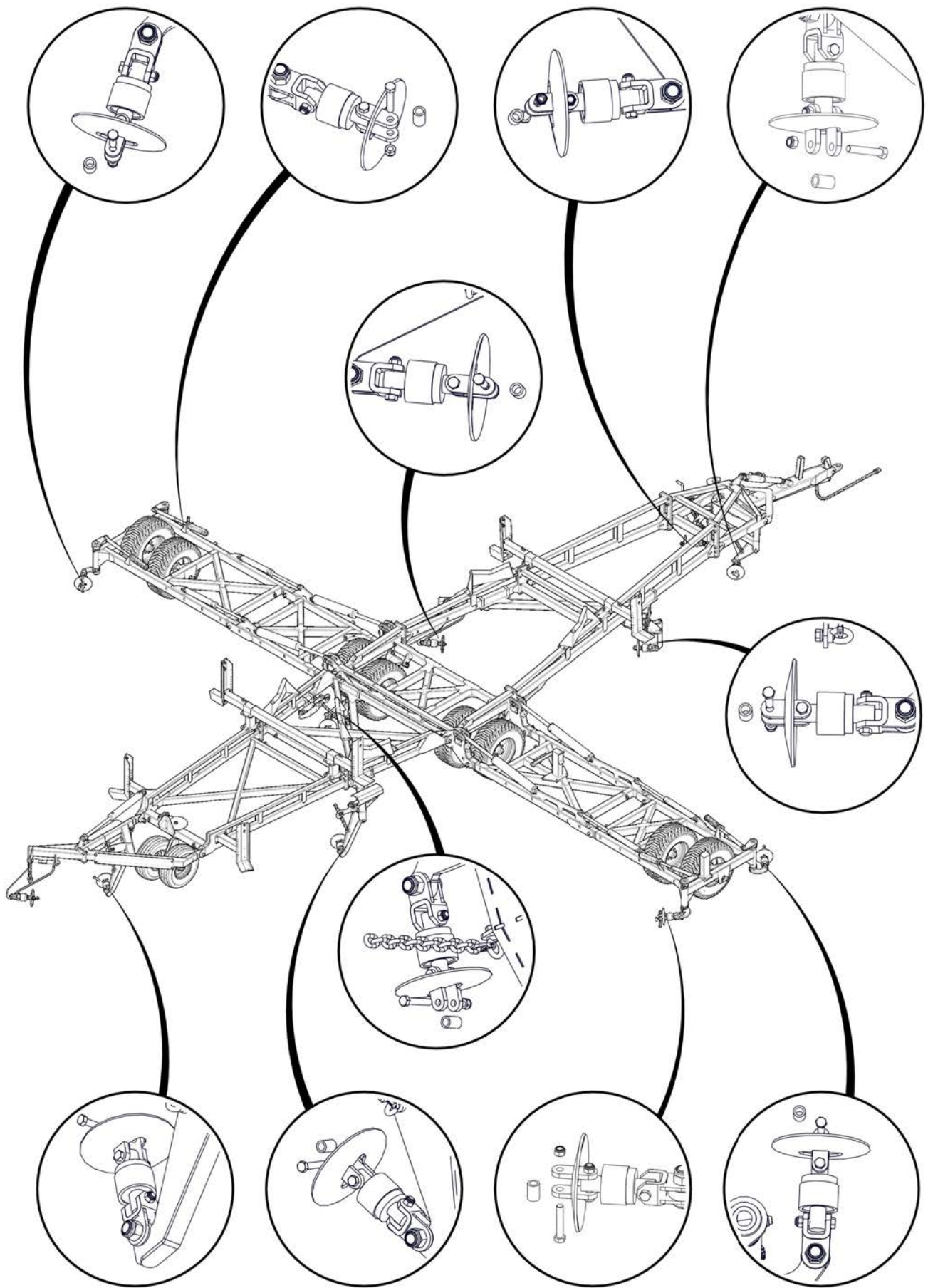

It's best to start at the fixed end with the hook opening facing up and work toward the adjusting end. This makes attaching the chain at the far end simpler.

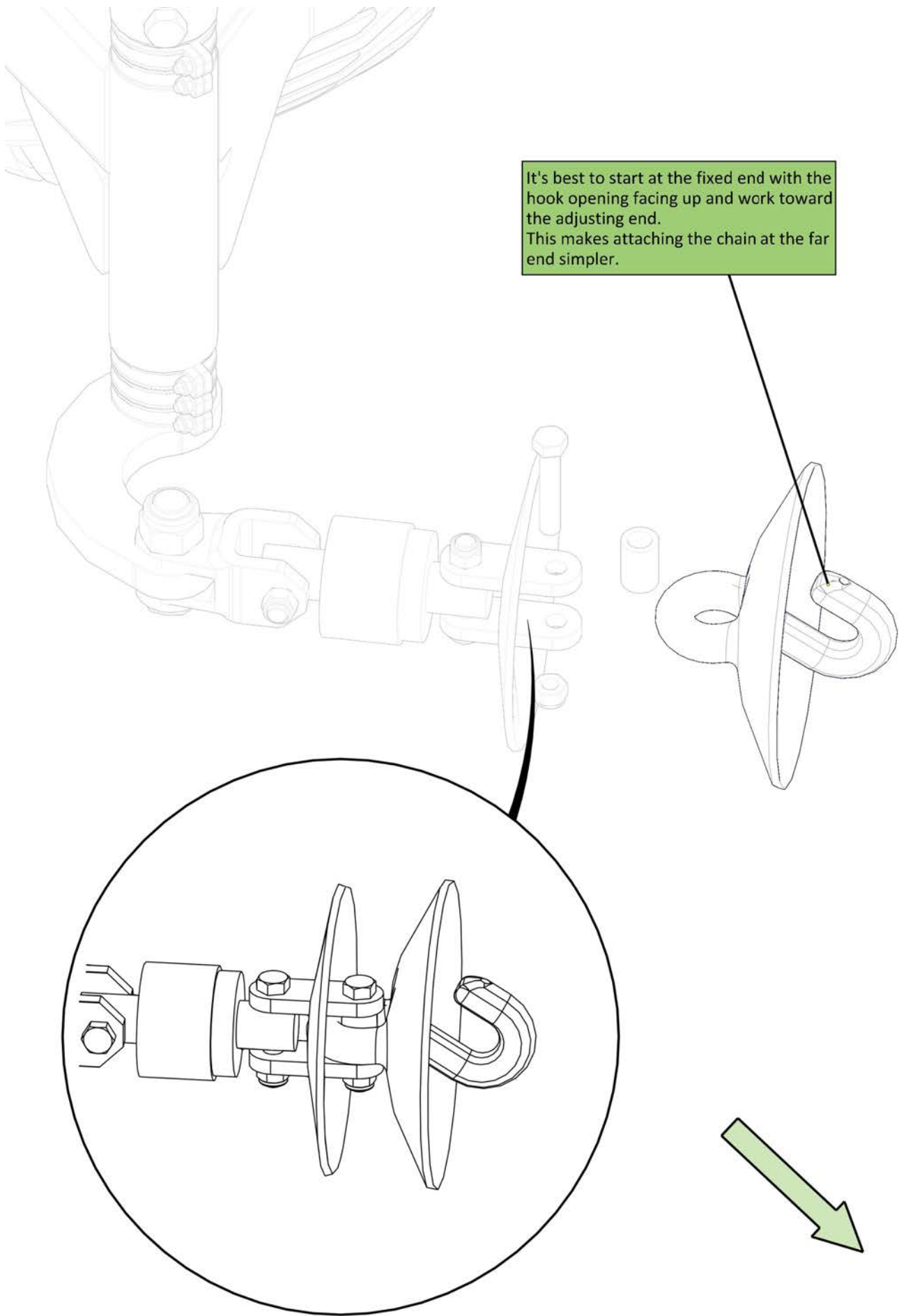

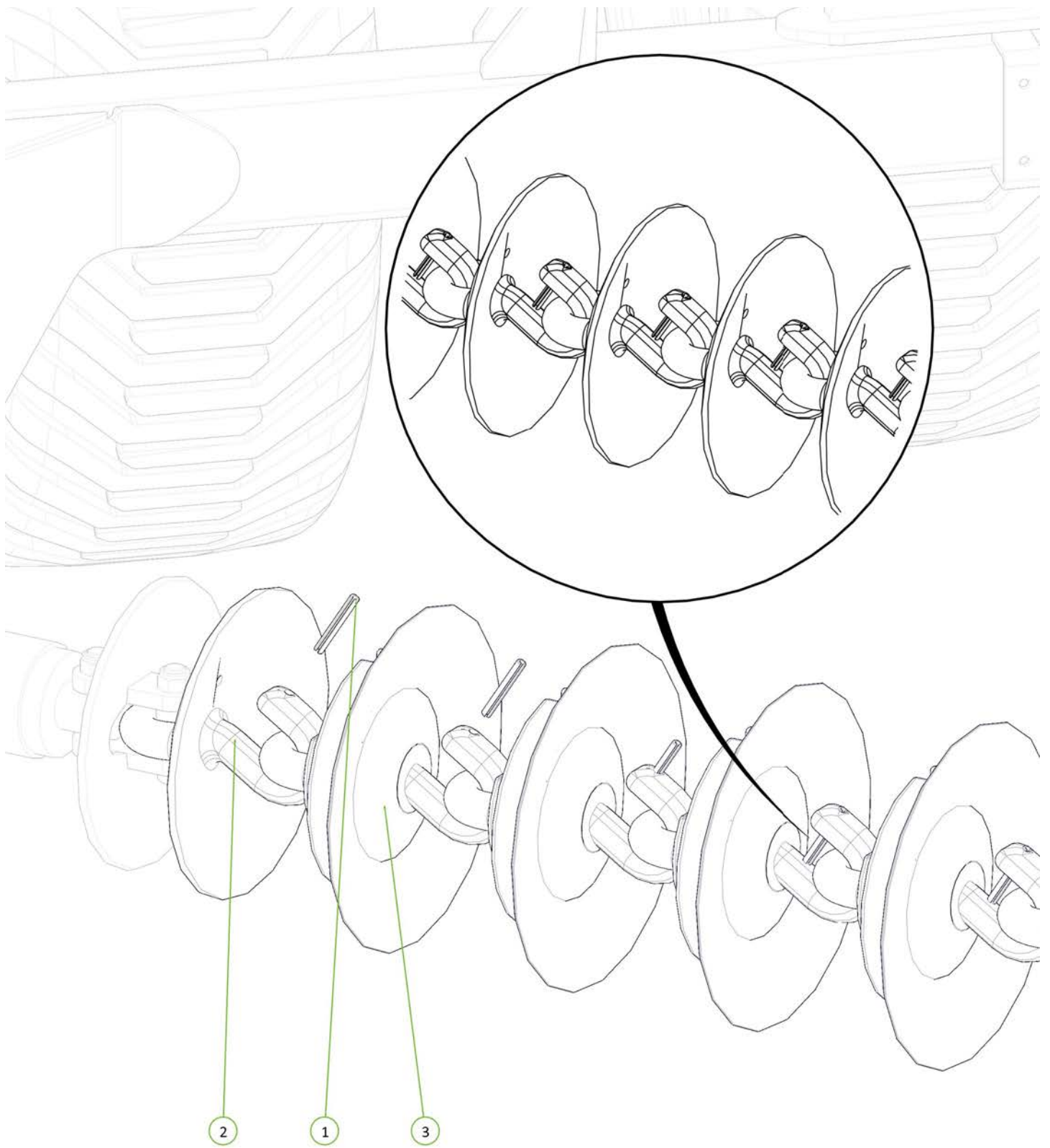

Item No.	Description	Qty	Number
1	Roll Pin Zinc Plated 3/8" x 3"	1	0262-3-8X3
2	CL1-B Chain Disc Link	1	0803-CL1
3	CL2-Link Assembly	1	0803-CL2-Link

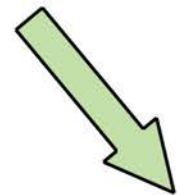

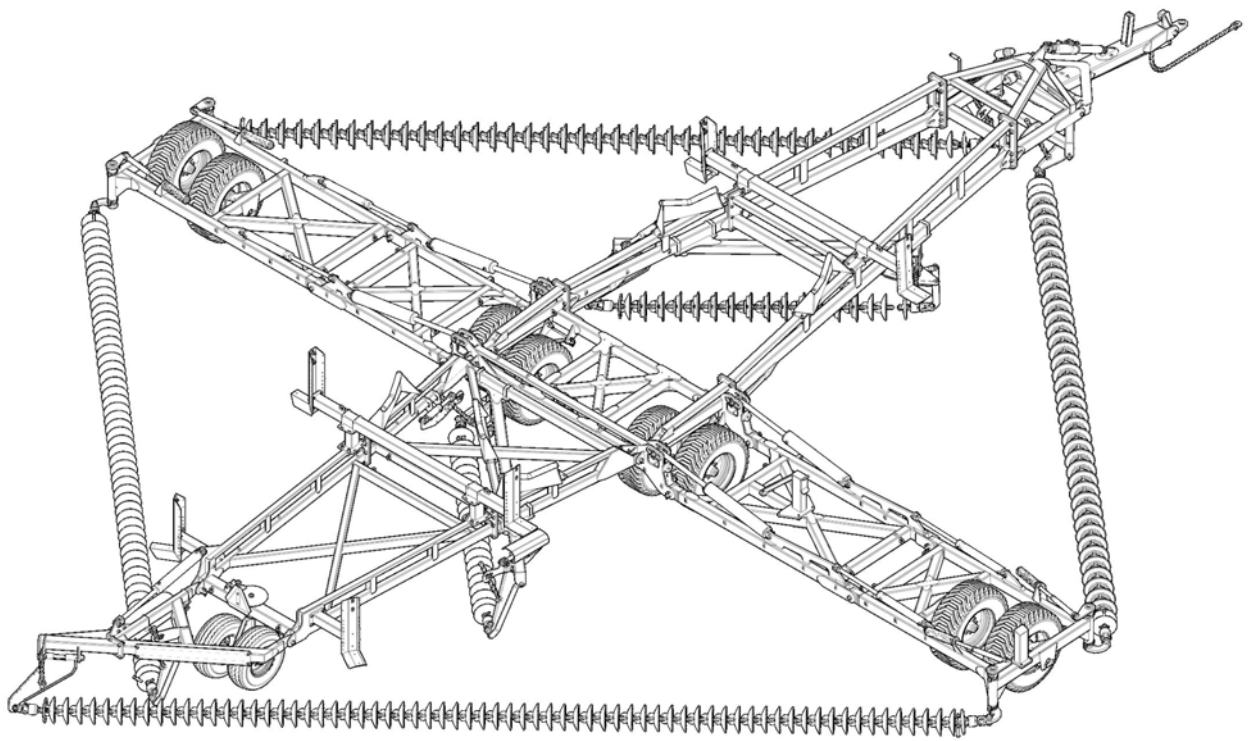

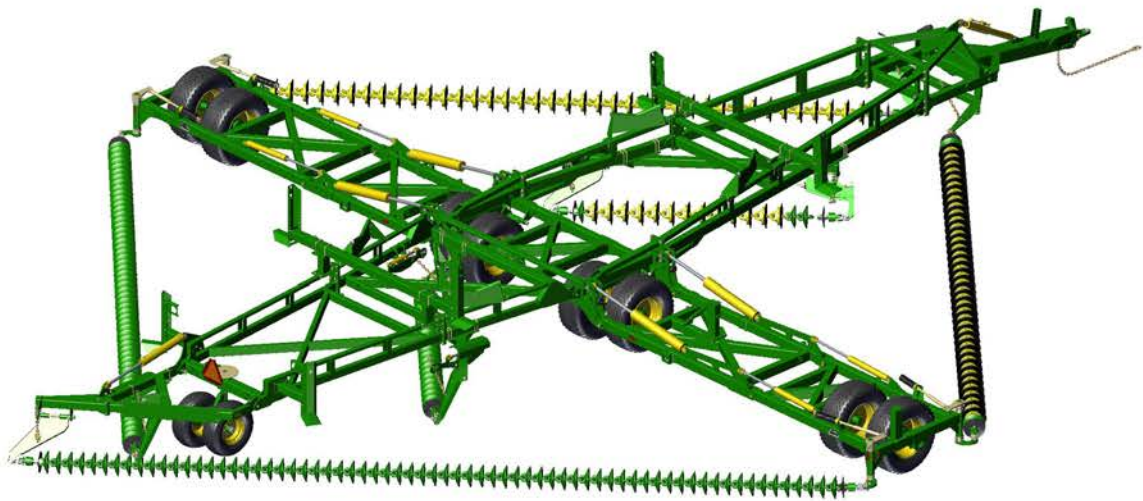

# Section 3

## Hydraulic Setup

Please note -  
Start at page 103 for machines that are  
part assembled on delivery

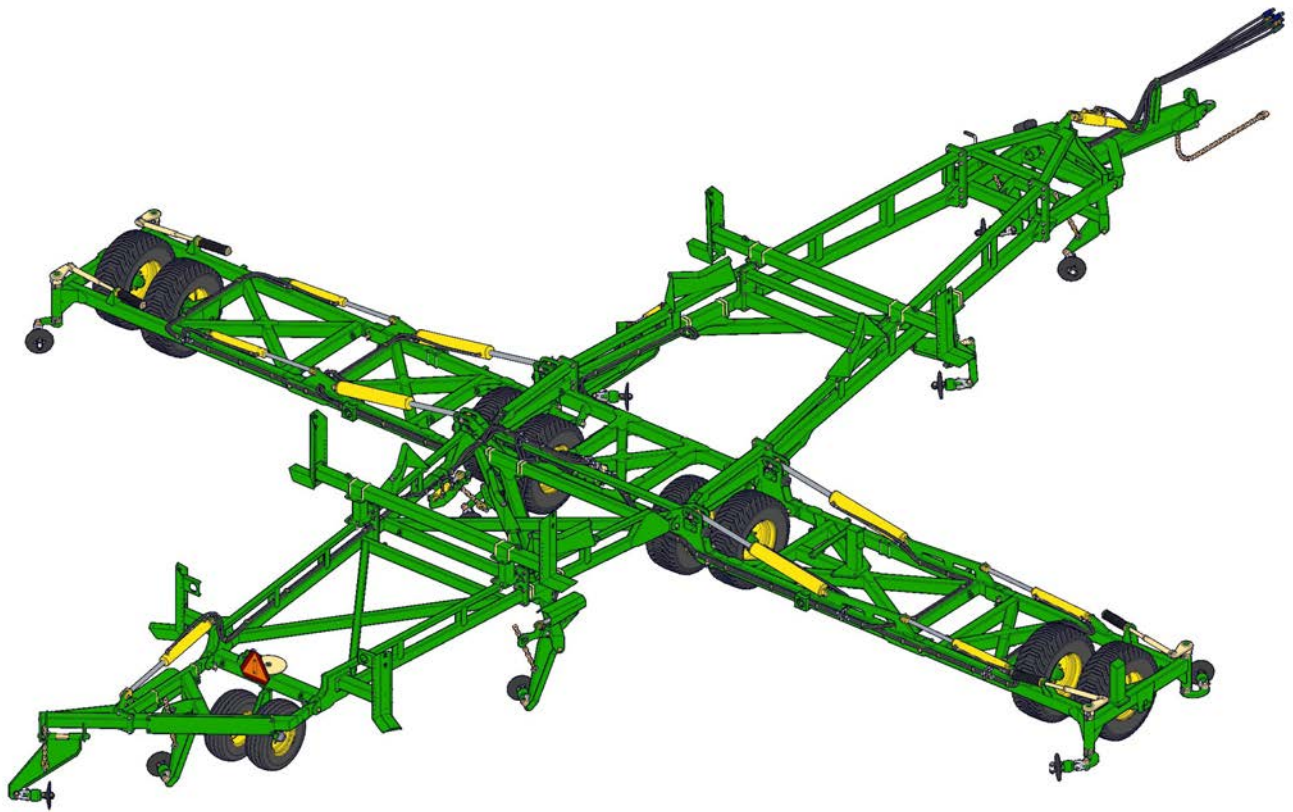

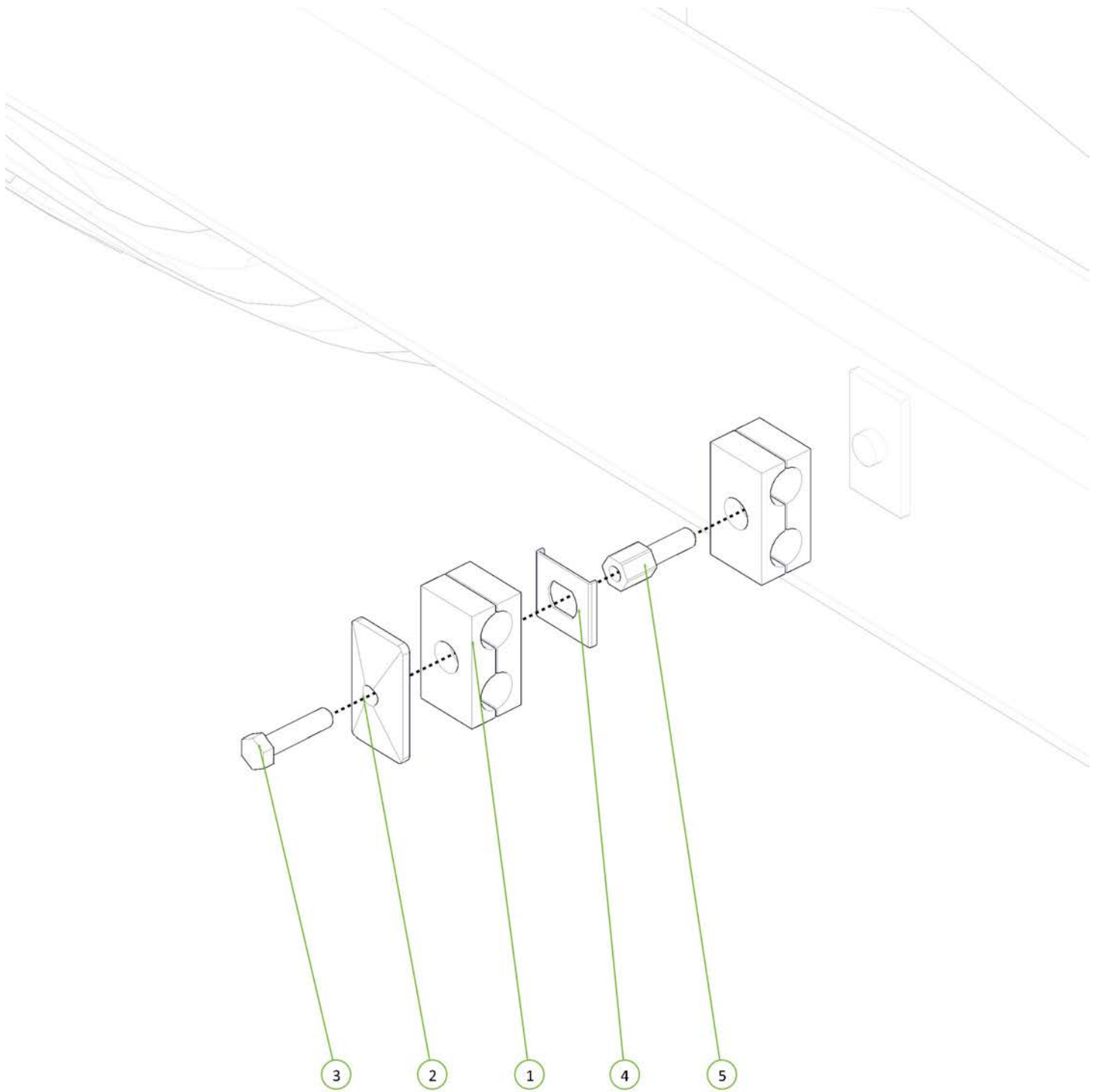

Item No.	Description	Qty	Number
1	RCD Double Clamp Jaws 17mm	2	0325-RCD-17J
2	RCD Double Clamp Top Plate No 2	1	0325-RCD-2PT
3	RCD Double Clamp Bolt No 2	1	0325-RCD-2BH
4	Double Clamp Stacking Plate (Non Ryco)	1	0325-SI-2-5D-W3
5	RCD Double Clamp Stacking Bolt No 2	1	0325-RCD-2BS



Item No.	Description	Qty	Number
1	Dual Circuit 3 Stage Sequence Manifold V12	1	0802-691033
2	M10 x 30 grade 8.8 ZP Bolt	6	0211-1030
3	Washer Spring M10	6	0231-S10
4	Washer Flat M10	6	0231-F10

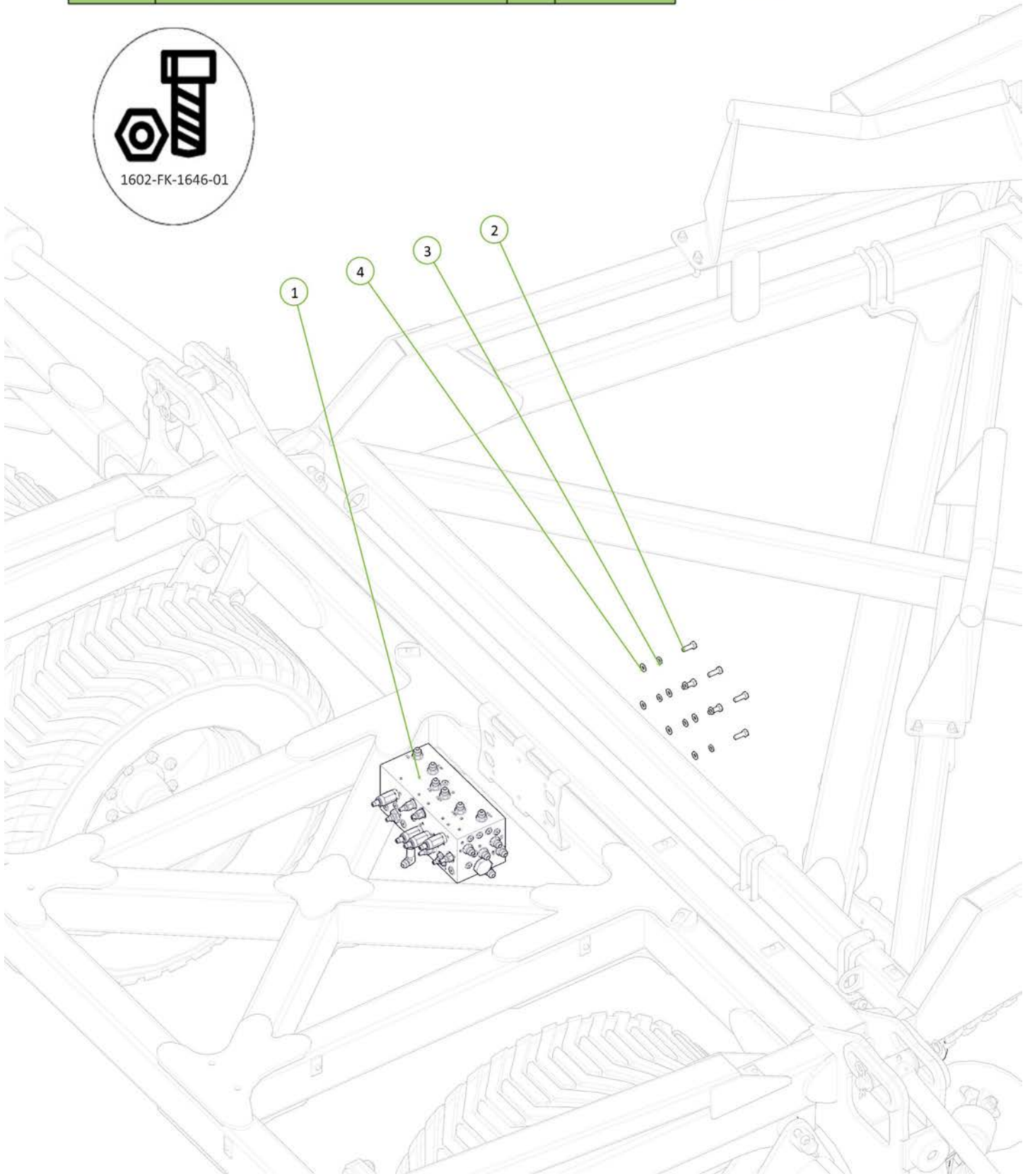
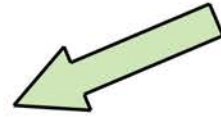

Item No.	Description	Qty	Number
1	TRACTOR TO SEQUENCE VALVE EXT1 PORT FITTED WITH GREEN EXT DECAL	1	H46-01-GE-EXT1
2	TRACTOR TO SEQUENCE VALVE RCT1 PORT FITTED WITH GREEN RET DECAL	1	H46-01-GR-RCT1
3	Green 1/2" NPT Hydra Grip Pair (Extend/Ret)	1	0325-HG-PT25E24R
4	BSPP QRC Ball Male Tip	2	0325-R91-08M

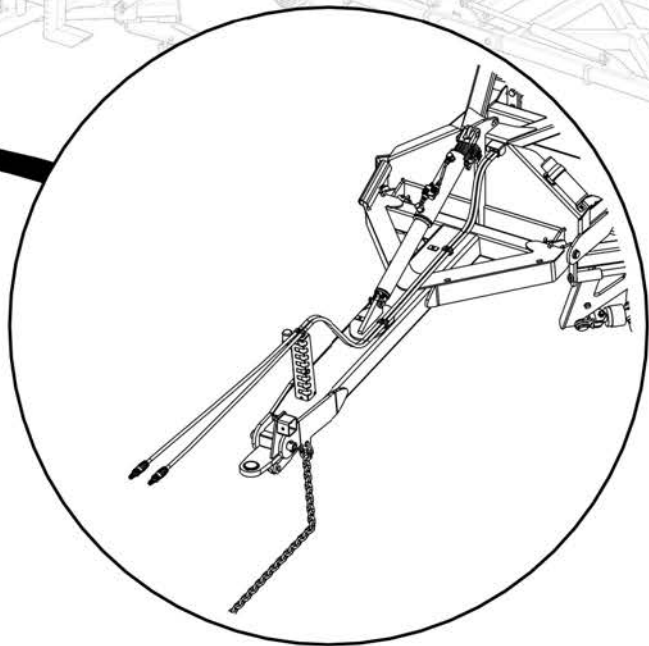
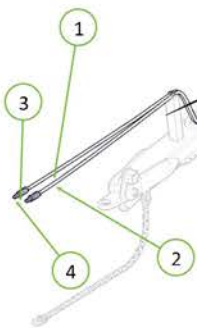
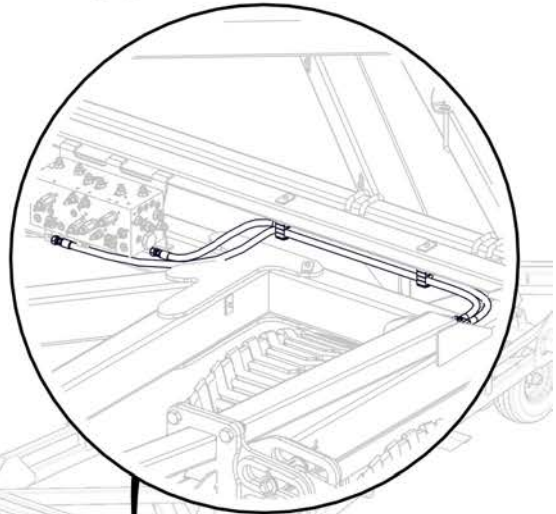
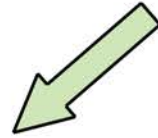
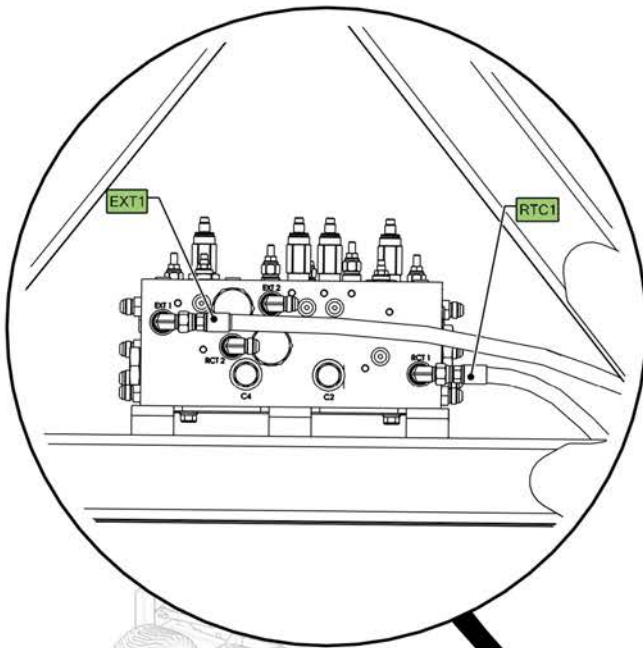

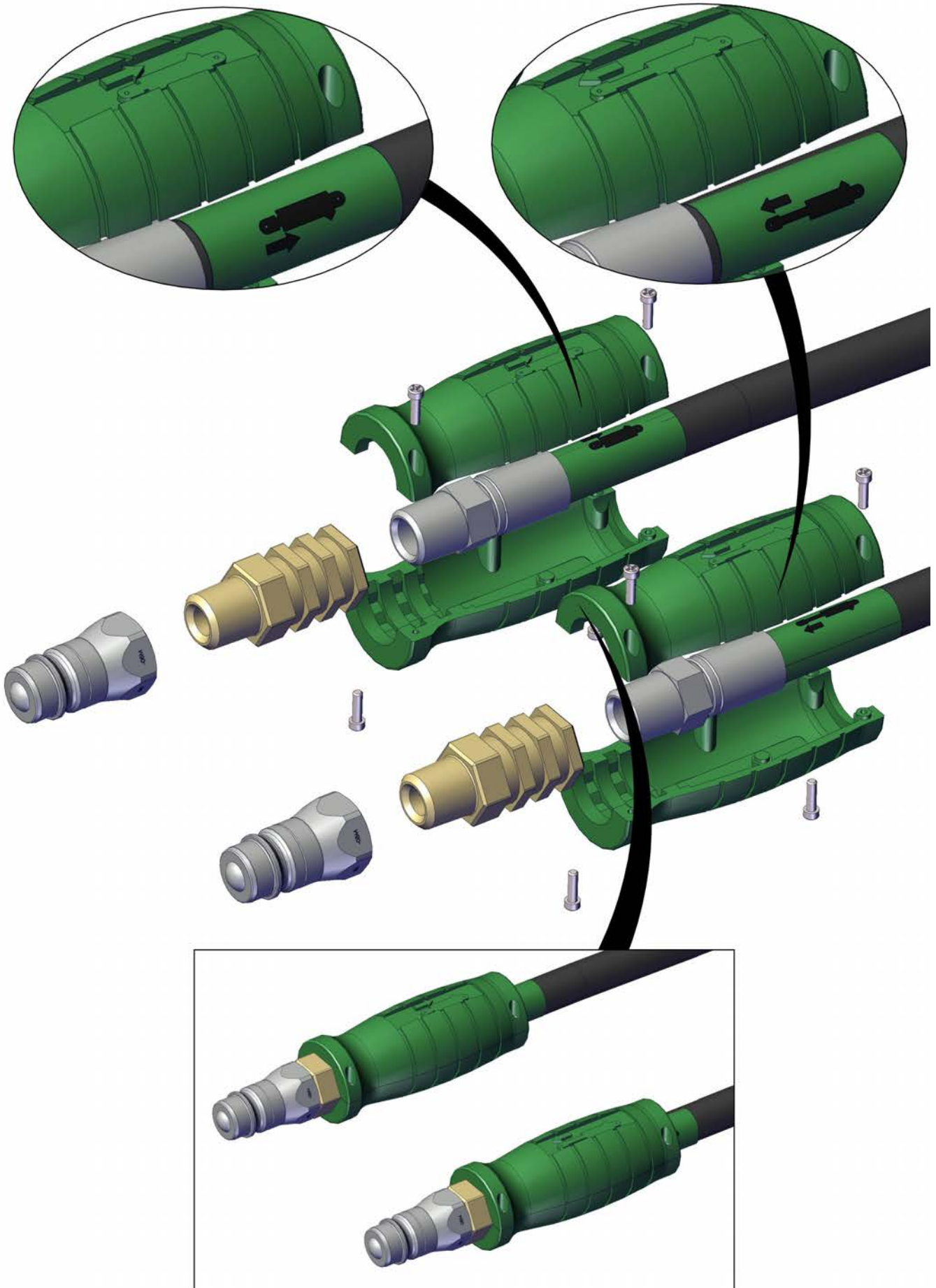

Item No.	Description	Qty	Number
1	TRACTOR TO SEQUENCE VALVE ECT2 PORT FITTED WITH YELLOW RET DECAL	1	H46-01-YR-RCT2
2	TRACTOR TO SEQUENCE VALVE EXT2 PORT FITTED WITH YELLOW EXT DECAL	1	H46-01-YE-EXT2
3	Yellow 1/2" NPT Hydra Grip Pair (Extend/Ret)	1	0325-HG-PT25E25R
4	BSPP QRC Ball Male Tip	2	0325-R91-08M

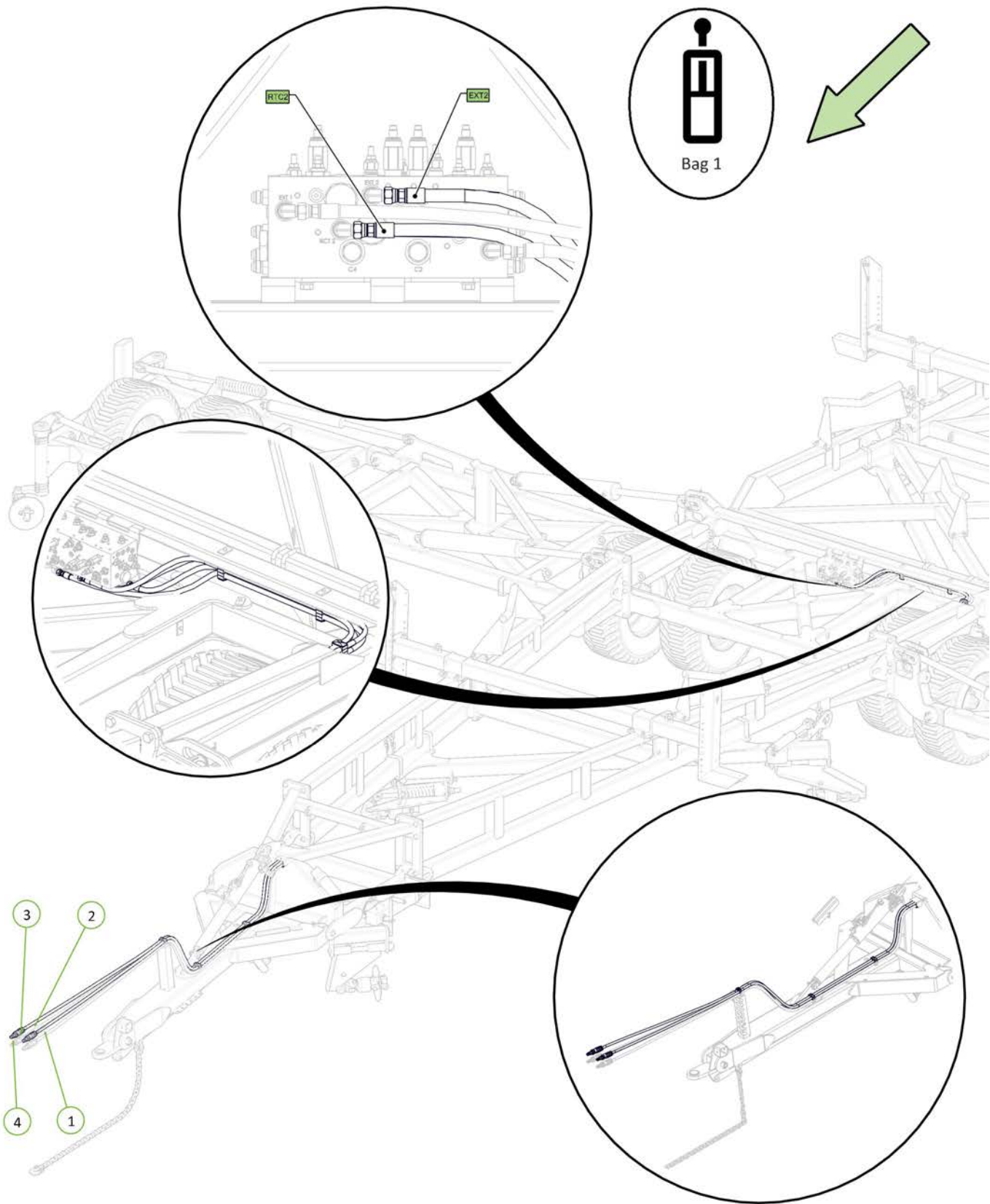

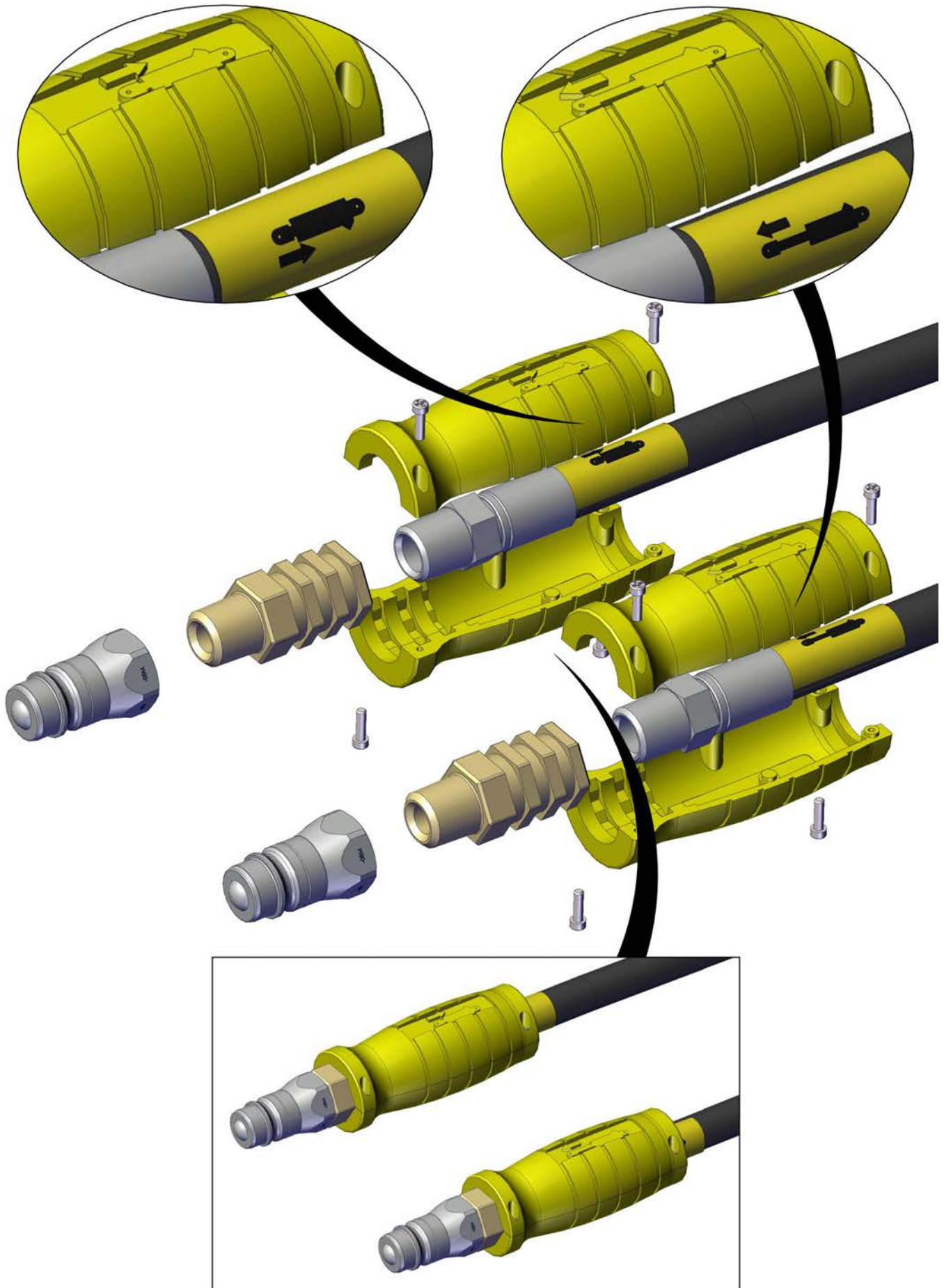

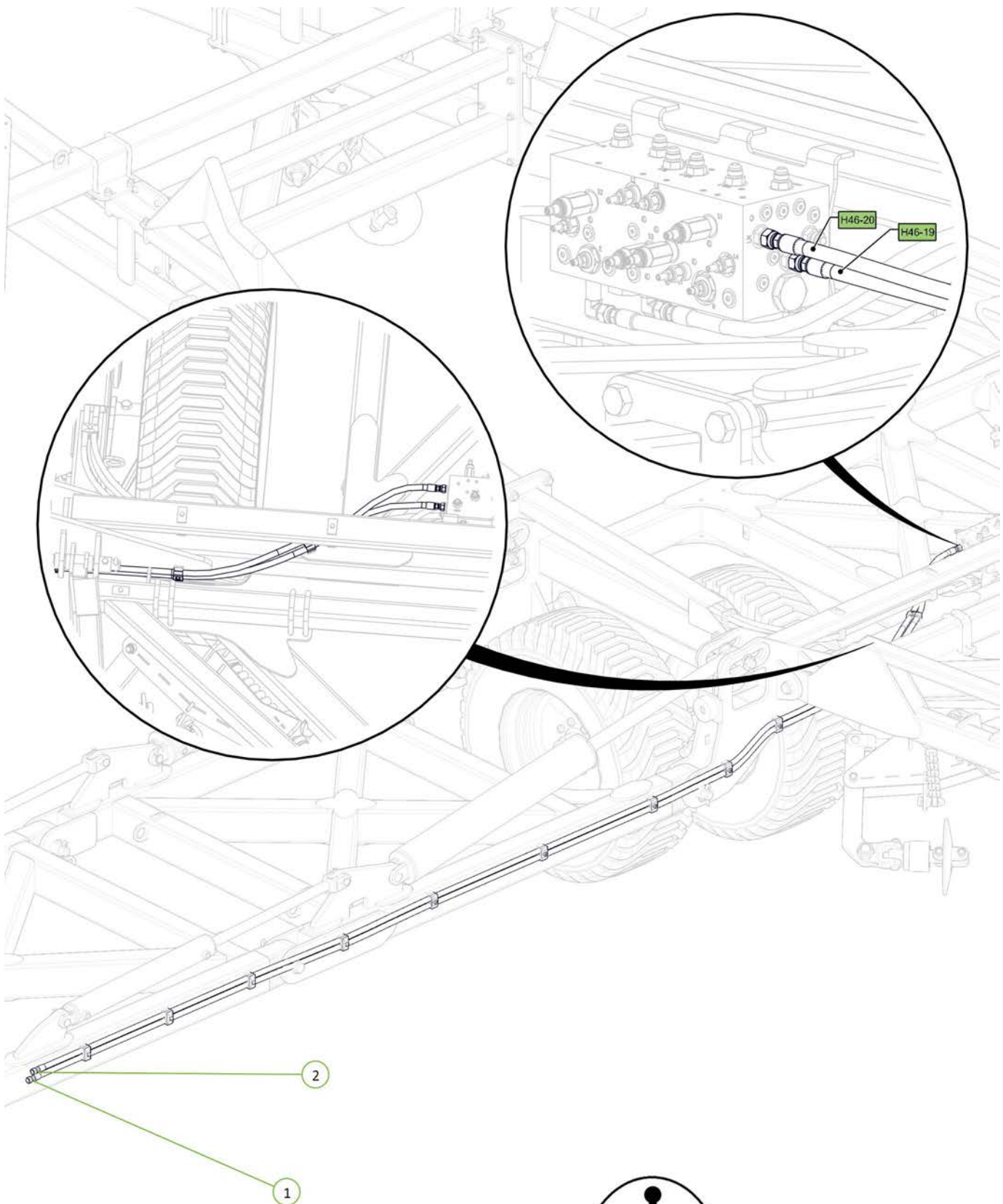

Item No.	Description	Qty	Number
1	LR PORT TO LH WING RETRACT TEE	1	H46-20
2	LE PORT TO LH WING EXTEND TEE	1	H46-19



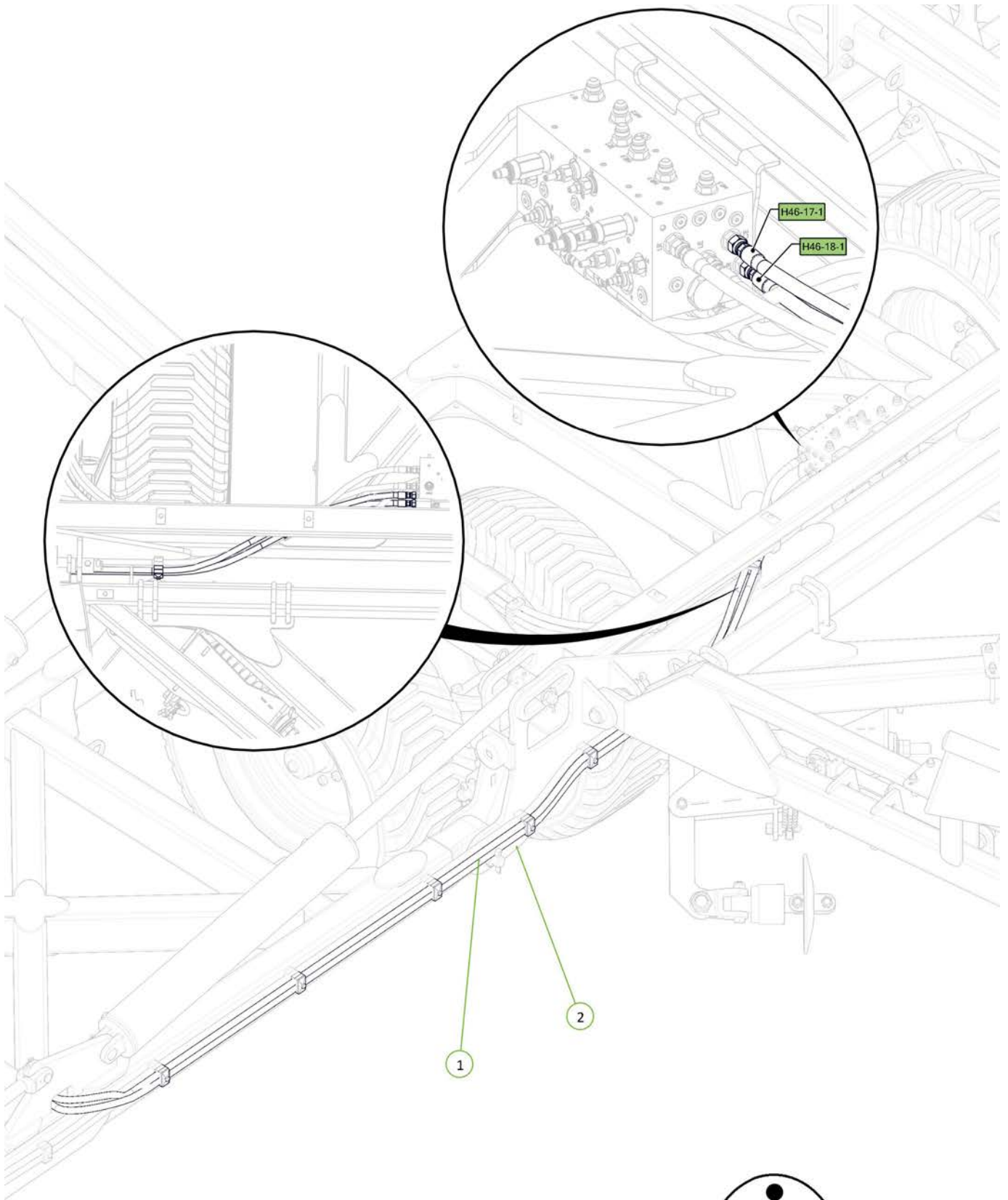

Item No.	Description	Qty	Number
1	LEFT CE PORT TO LH MAIN WING CYLINDER EXTEND TEE	1	H46-17-1
2	LEFT CR PORT TO LH MAIN WING CYLINDER RETRACT TEE	1	H46-18-1

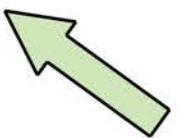

Item No.	Description	Qty	Number
1	3/4" JIC Male 3/4" UN O Ring Male 90° Elbow	2	0323-S91-1212
2	3/4" JIC Male Tee	2	0324-S19-121212
3	LH MAIN WING CYLINDER EXTEND TEE TO LH REAR MAIN CYLINDER EXTEND PORT	1	H46-17-2
4	LH MAIN WING CYLINDER EXTEND TEE TO LH FRONT MAIN CYLINDER EXTEND PORT	1	H46-17-3
5	LH MAIN WING CYLINDER RETRACT TEE TO LH REAR MAIN CYLINDER RETRACT PORT	1	H46-18-2
6	LH MAIN WING CYLINDER RETRACT TEE TO LH FRONT MAIN CYLINDER RETRACT PORT	1	H46-18-3

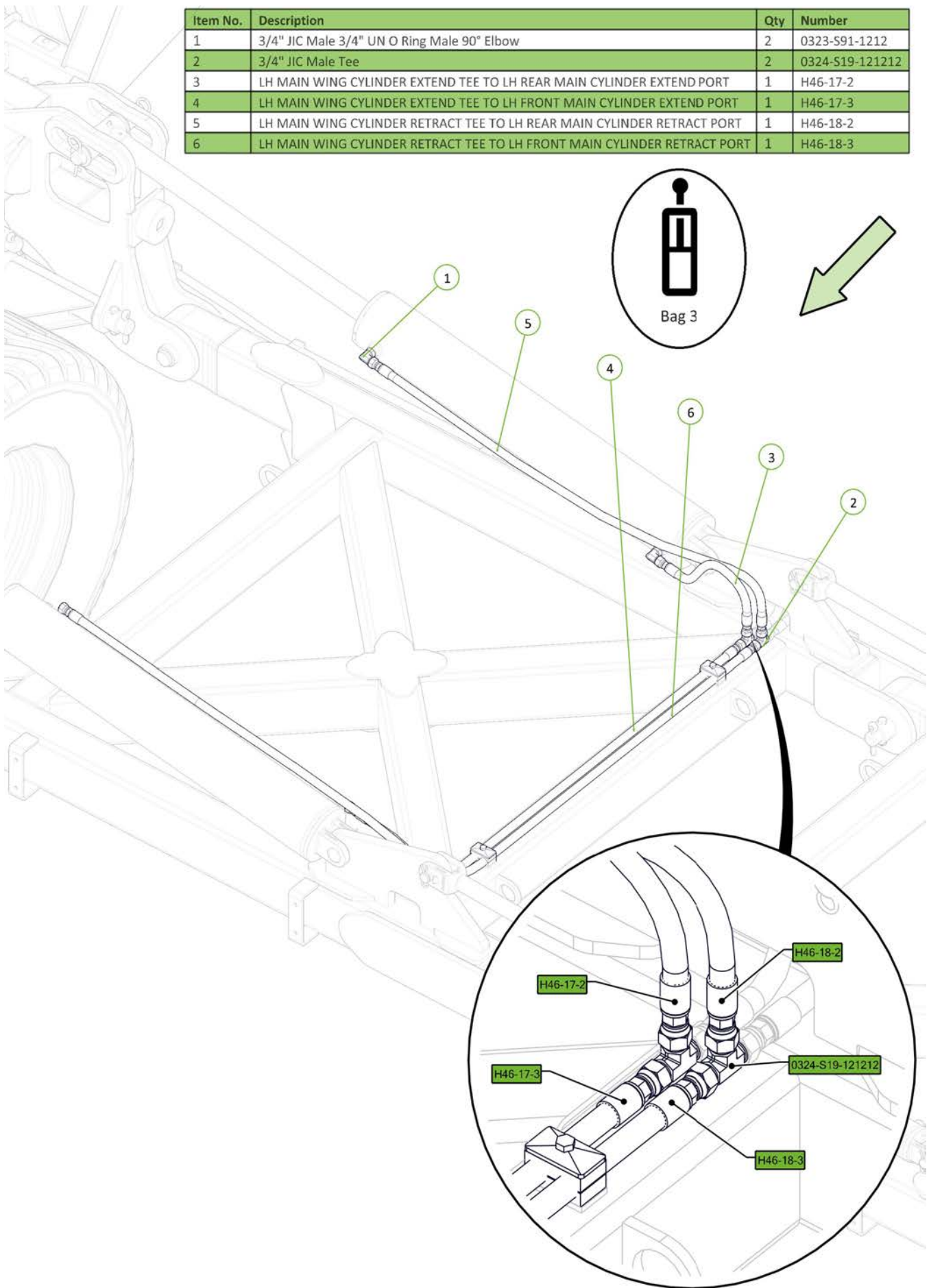



Item No.	Description	Qty	Number
1	LH WING EXTEND TEE TO LH REAR OUTER WING CYLINDER EXTEND PORT	1	H46-21
2	LH WING RETRACT TEE TO LH REAR OUTER WING CYLINDER RETRACT PORT	1	H46-22
3	JIC/UNO 90 Elbow	2	0323-591-1212
4	JICM JICM JICM TEE	2	0324-S19-121212

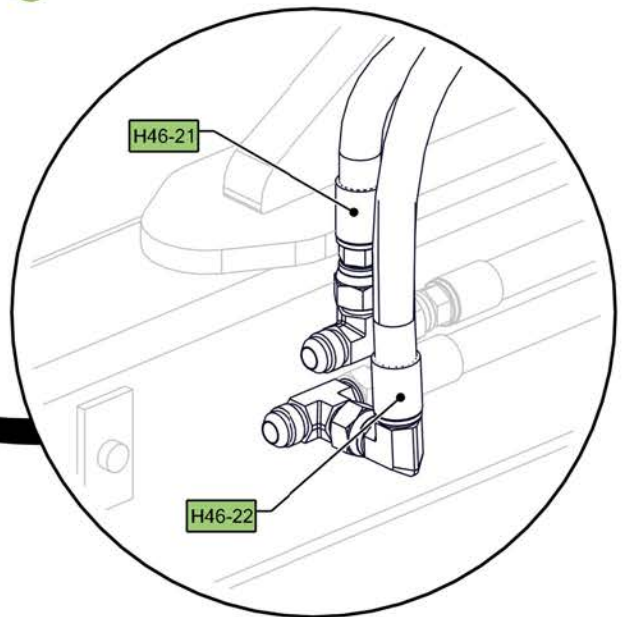
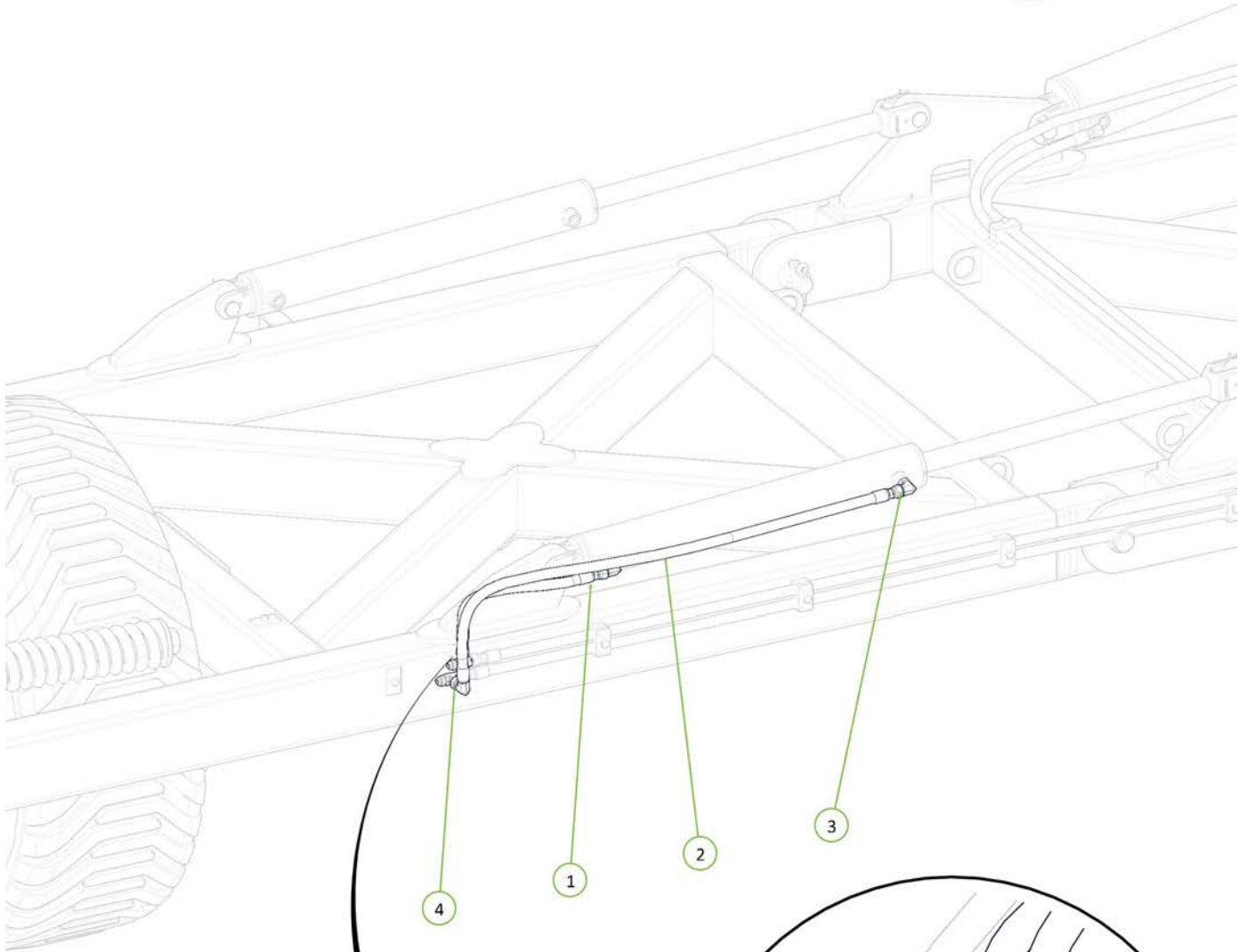
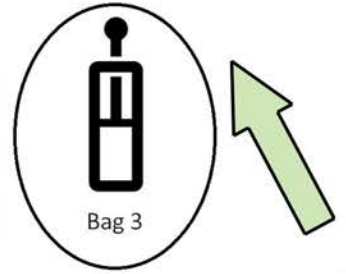

Item No.	Description	Qty	Number
1	LH WING EXTEND TEE TO LH FRONT OUTER WING CYLINDER EXTEND PORT	1	H46-23
2	LH WING RETRACT TEE TO LH FRONT OUTER WING CYLINDER RETRACT PORT	1	H46-24
3	JIC/UNO 90 Elbow	2	0323-S91-1212

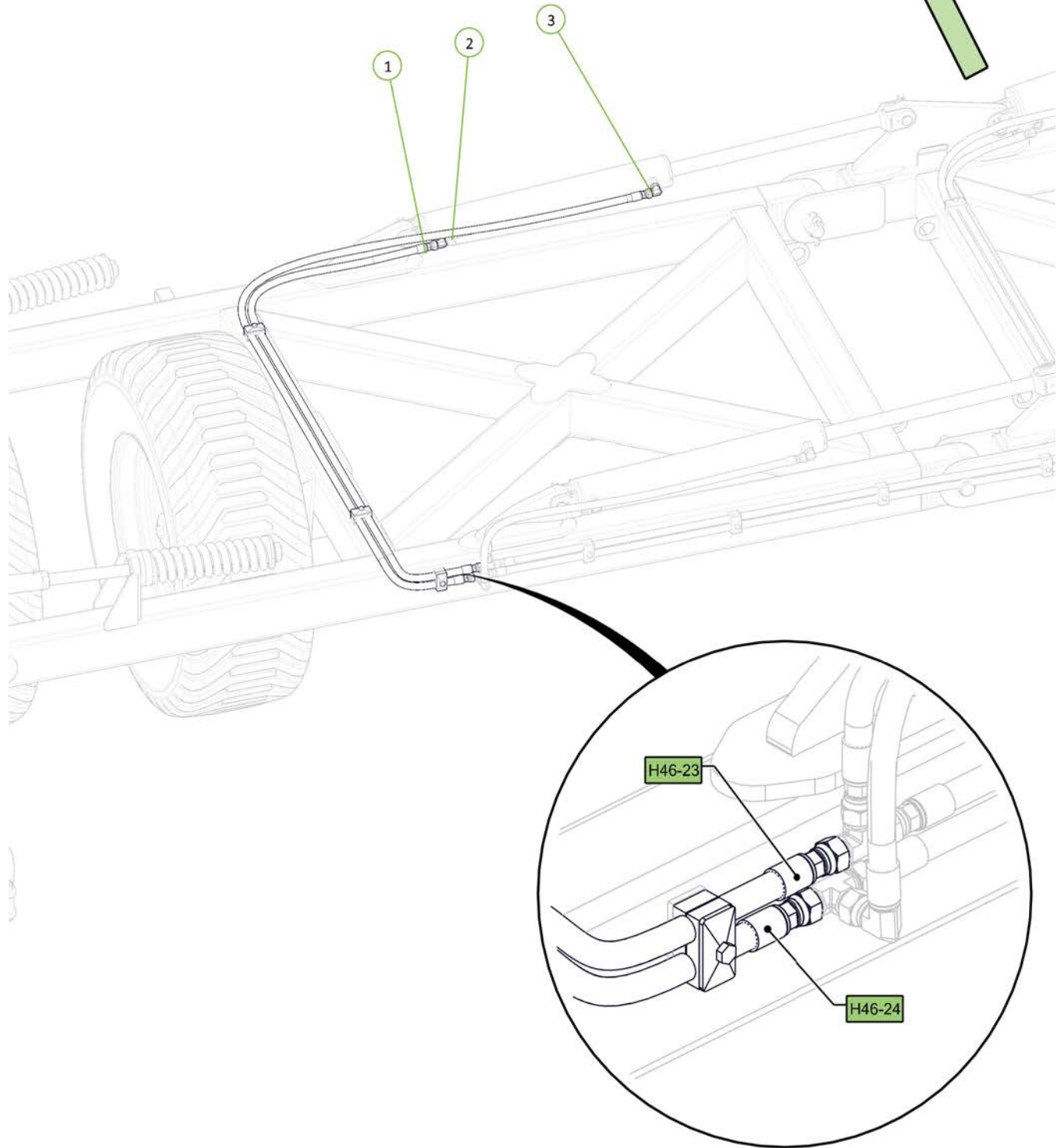

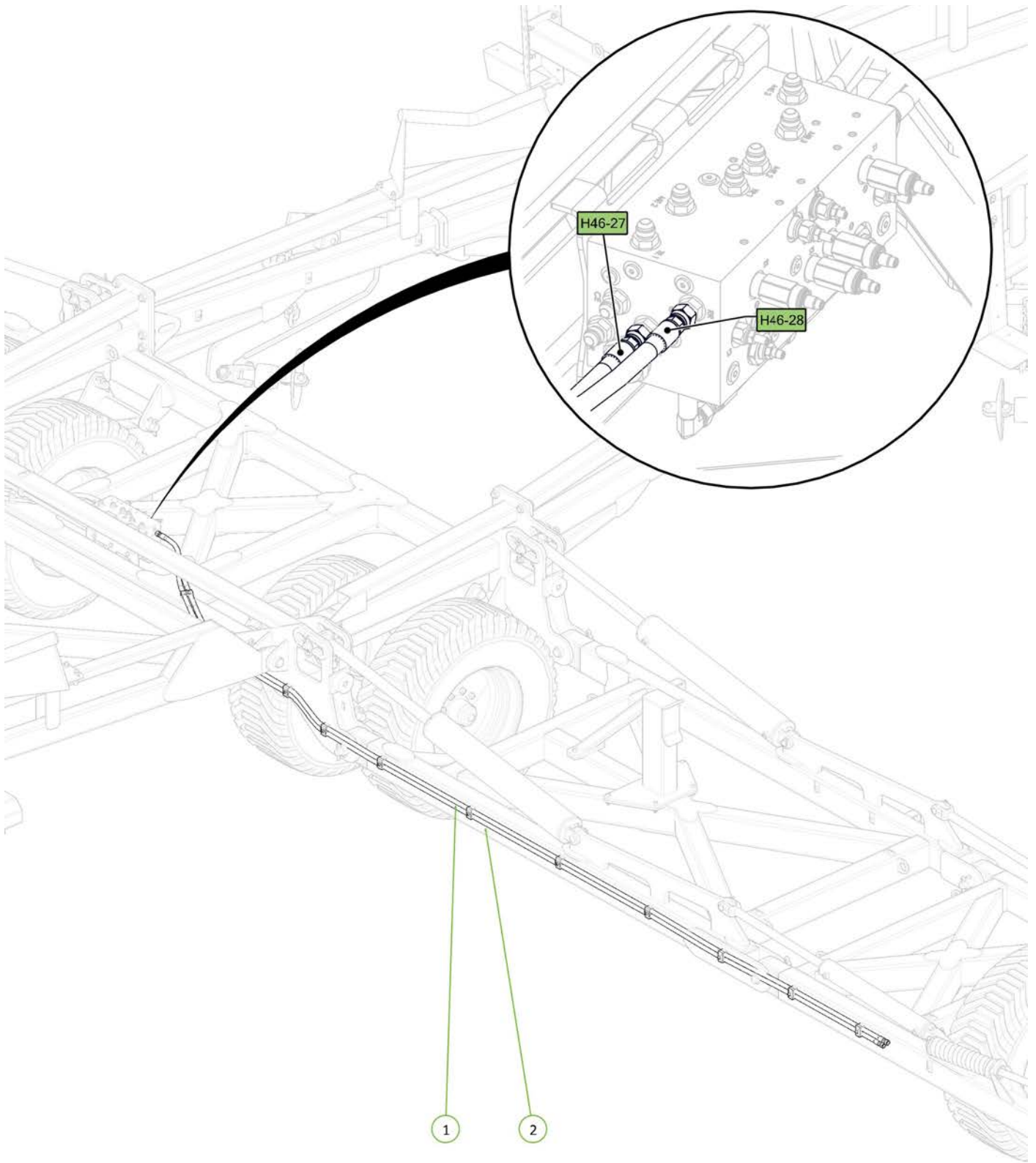

Item No.	Description	Qty	Number
1	RE PORT TO RH WING EXTEND TEE	1	H46-27
2	RR PORT TO RH WING RETRACT TEE	1	H46-28

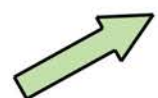

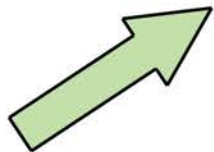
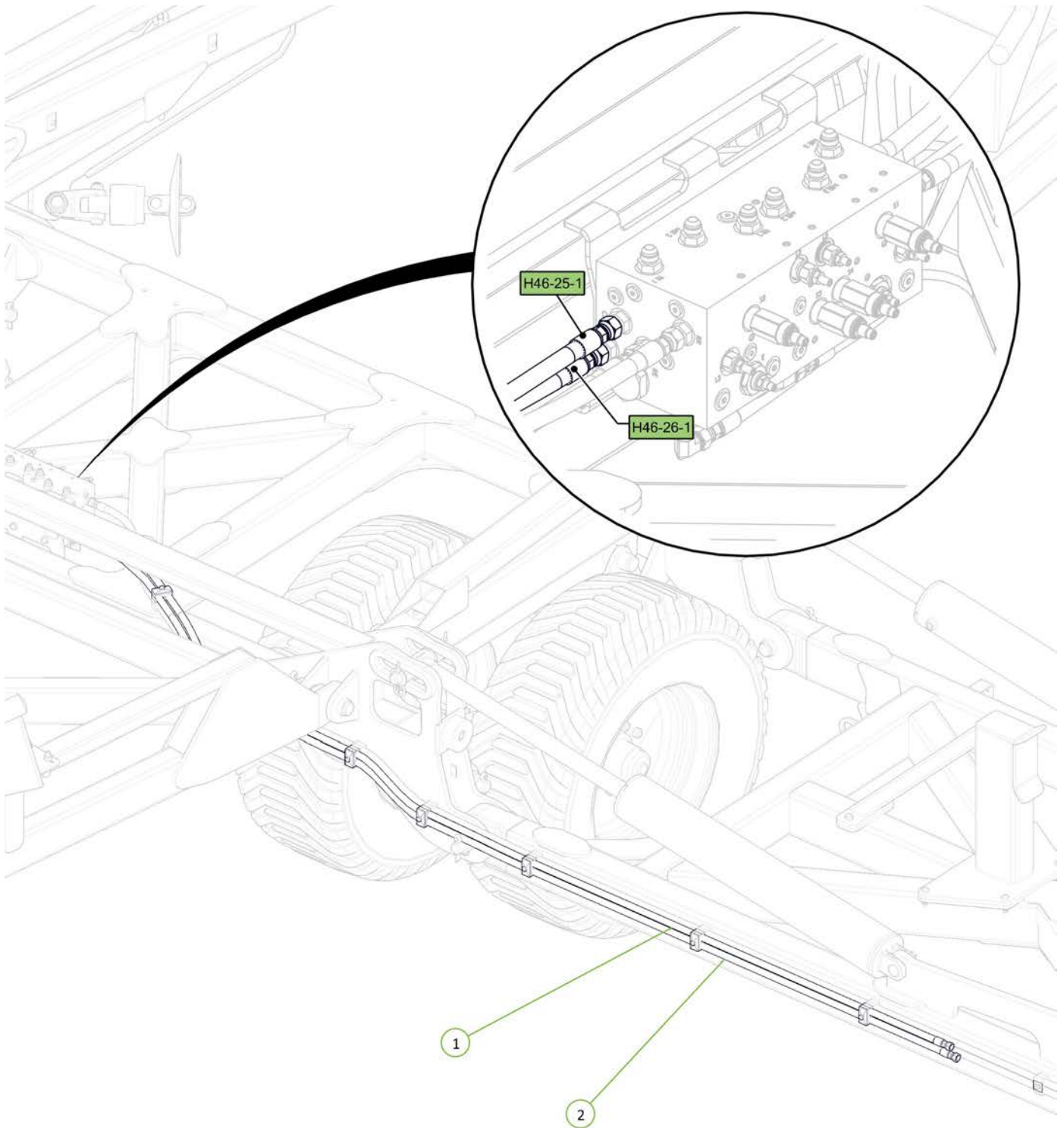

Item No.	Description	Qty	Number
1	RIGHT CE PORT TO RH MAIN WING CYLINDER EXTEND PORT	1	H46-25-1
2	RIGHT CR PORT TO RH MAIN WING CYLINDER RETRACT PORT	1	H46-26-1



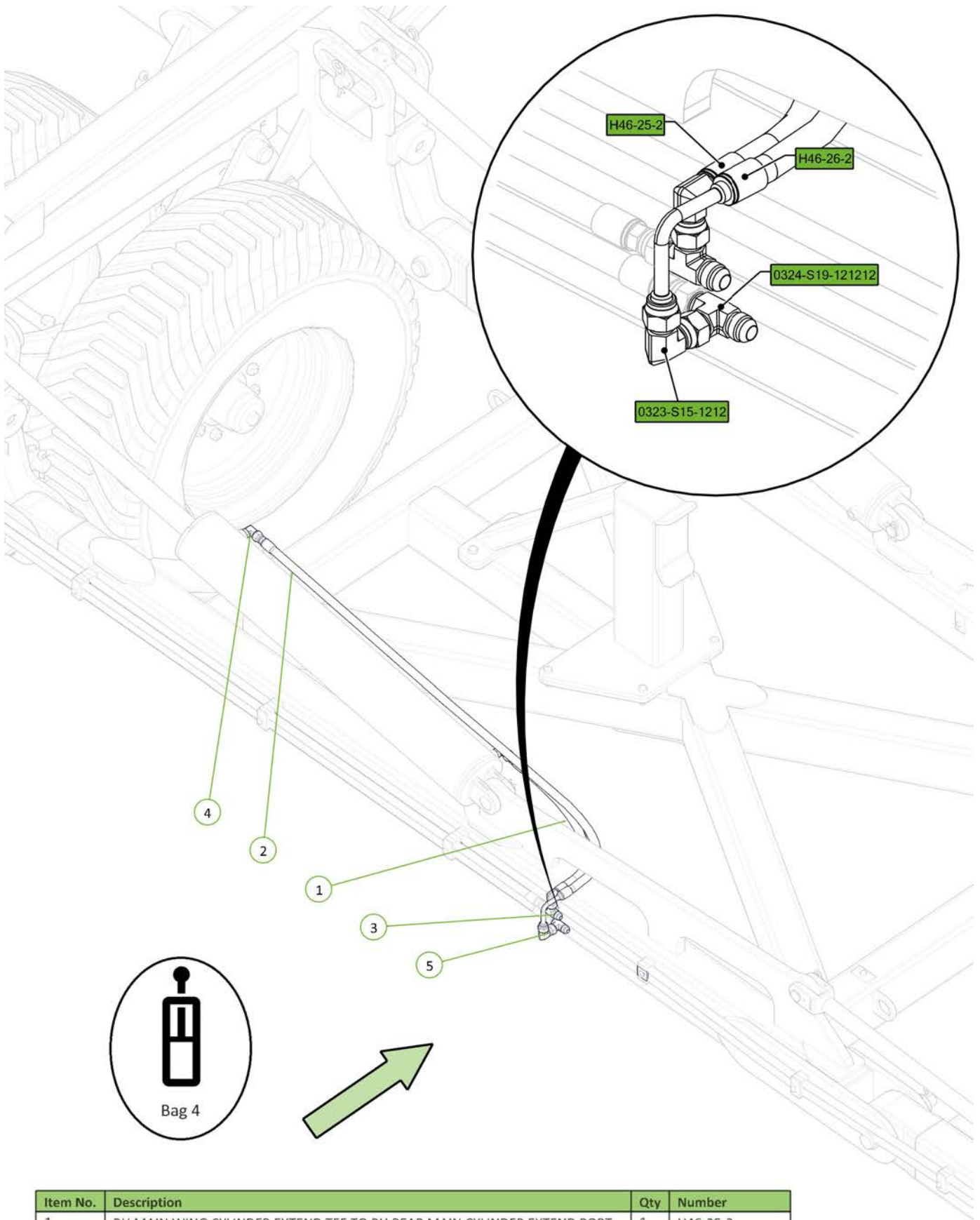

Item No.	Description	Qty	Number
1	RH MAIN WING CYLINDER EXTEND TEE TO RH REAR MAIN CYLINDER EXTEND PORT	1	H46-25-2
2	RH MAIN WING CYLINDER RETRACT TEE TO RH REAR MAIN CYLINDER RETRACT PORT	1	H46-26-2
3	3/4" JIC Male Tee	2	0324-S19-1212
4	3/4" JIC Male 3/4" UN O Ring Male 90° Elbow	2	0323-S91-1212
5	3/4" JIC Male 3/4" JIC Female Swivel 90° Elbow	1	0323-S15-1212

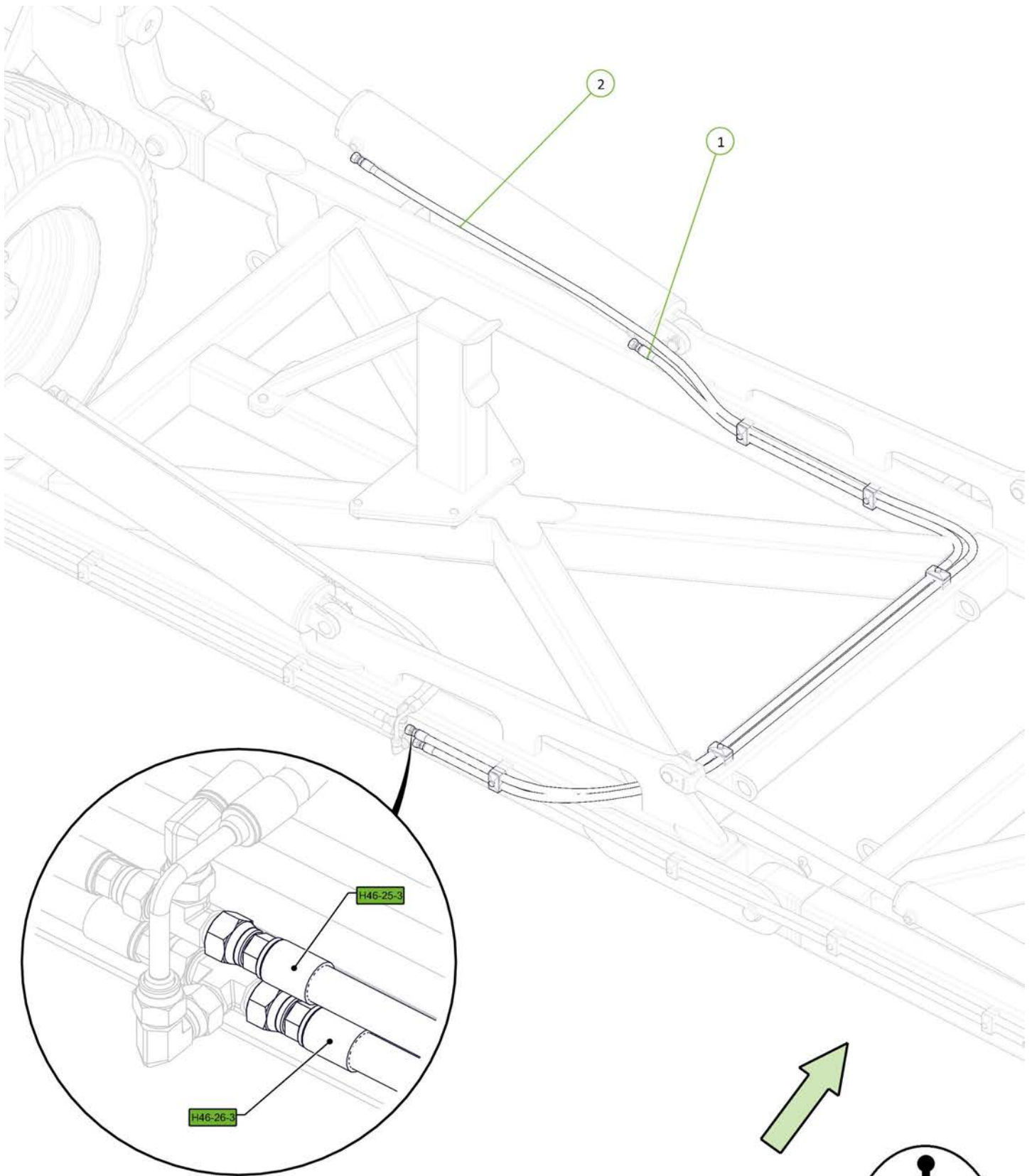

Item No.	Description	Qty	Number
1	RH MAIN WING CYLINDER EXTEND TEE TO RH FRONT MAIN CYLINDER EXTEND PORT	1	H46-25-3
2	RH MAIN WING CYLINDER RETRACT TEE TO RH FRONT MAIN CYLINDER RETRACT PORT	1	H46-26-3



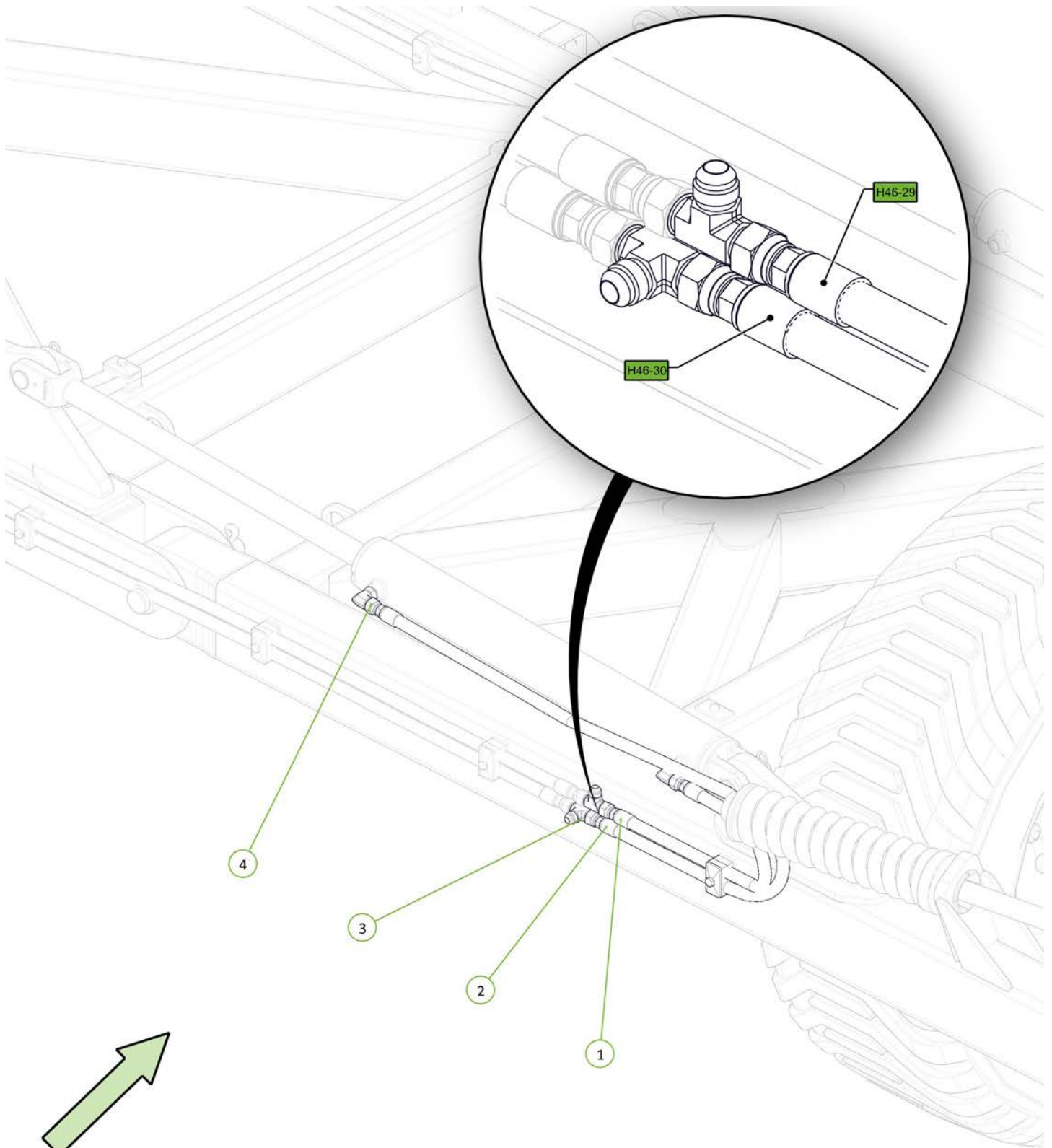

Item No.	Description	Qty	Number
1	RH WING EXTEND TEE TO RH REAR OUTER WING CYLINDER EXTEND PORT	1	H46-29
2	RH WING RETRACT TEE TO RH REAR OUTER WING CYLINDER RETRACT PORT	1	H46-30
3	JICM JICM JICM TEE	2	0324-S19-121212
4	3/4" JIC Male 3/4" UN O Ring Male 90° Elbow	2	0323-S91-1212



Item No.	Description	Qty	Number
1	RH WING EXTEND TEE TO RH FRONT OUTER WING CYLINDER EXTEND PORT	1	H46-31
2	RH WING RETRACT TEE TO RH FRONT OUTER WING CYLINDER RETRACT PORT	1	H46-32
3	JICM JICFS 90° ELBOW	1	0323-S15-1212
4	JIC/UNO 90 Elbow	2	0323-S91-1212

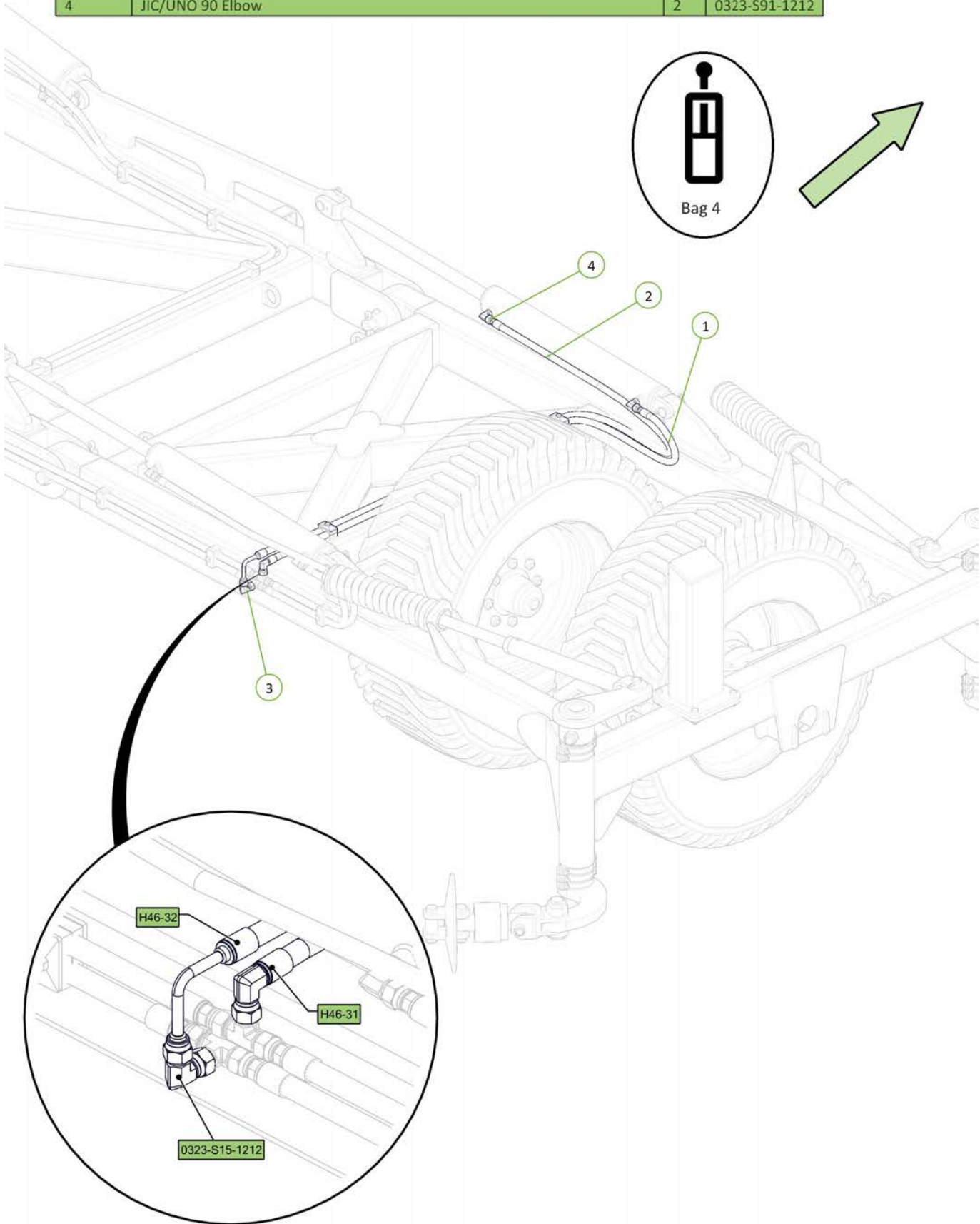
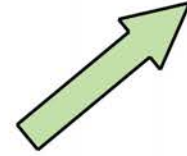



Item No.	Description	Qty	Number
1	TE1 PORT TO TAIL LIFT CYLINDER EXTEND PORT	1	H46-05
2	TR1 PORT TO TAIL LIFT CYLINDER RETRACT PORT	1	H46-06
3	JIC/UNO 90 Elbow	2	0323-S91-1212

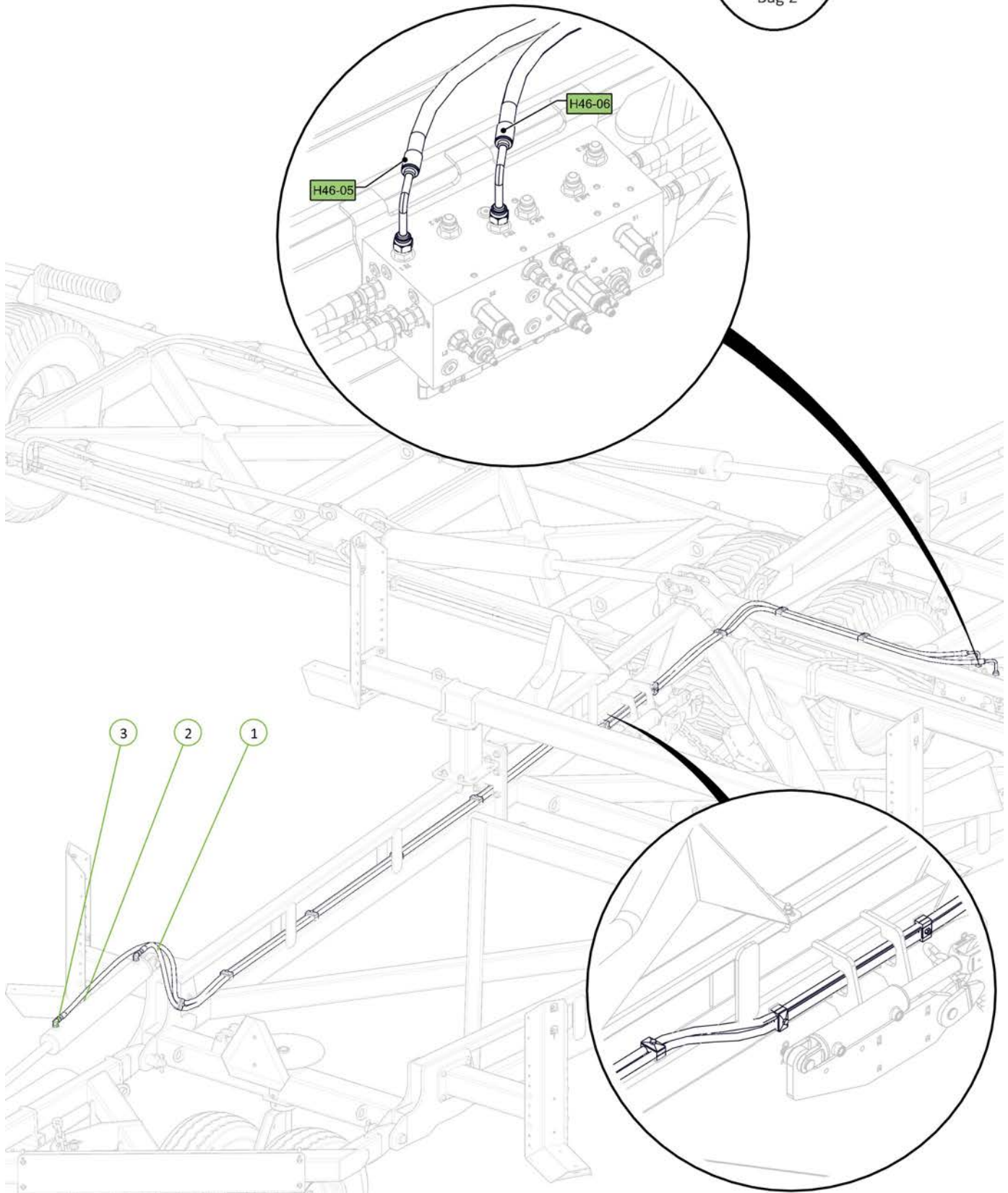
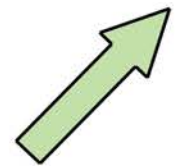

Item No.	Description	Qty	Number
1	MR2 TO REAR MODULE RETRACT TEE	1	H46-12
2	ME2 TO REAR MODULE EXTEND TEE	1	H46-11

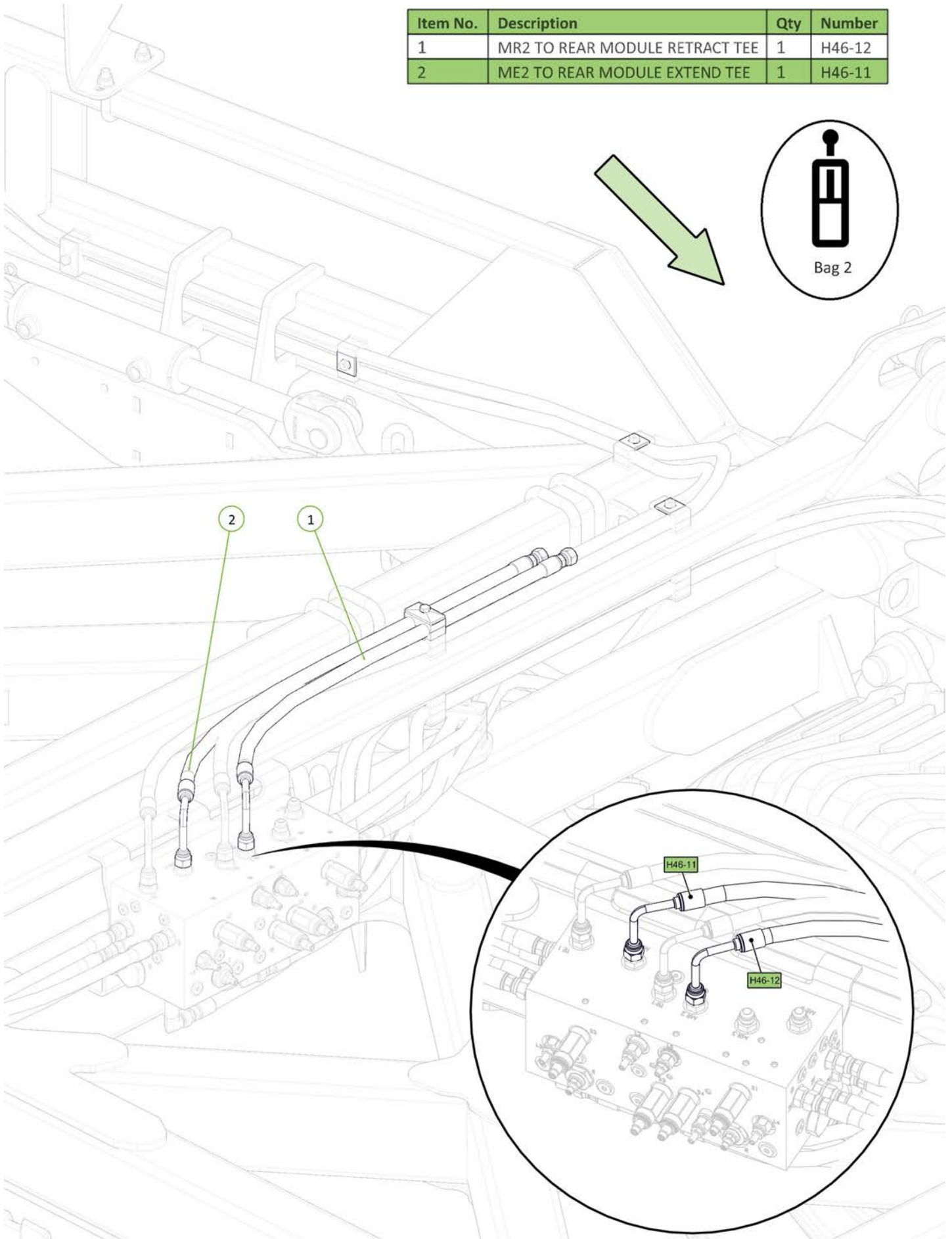

Item No.	Description	Qty	Number
1	REAR MODULE EXTEND TEE TO LH REAR MODULE CYL EXTEND PORT	1	H46-13
2	REAR MODULE RETRACT TEE TO LH REAR MODULE CYL RETRACT PORT	1	H46-14
3	JIC/UNO 90 Elbow	2	0323-S91-1212
4	JICM JICM JICM TEE	2	0324-S19-121212

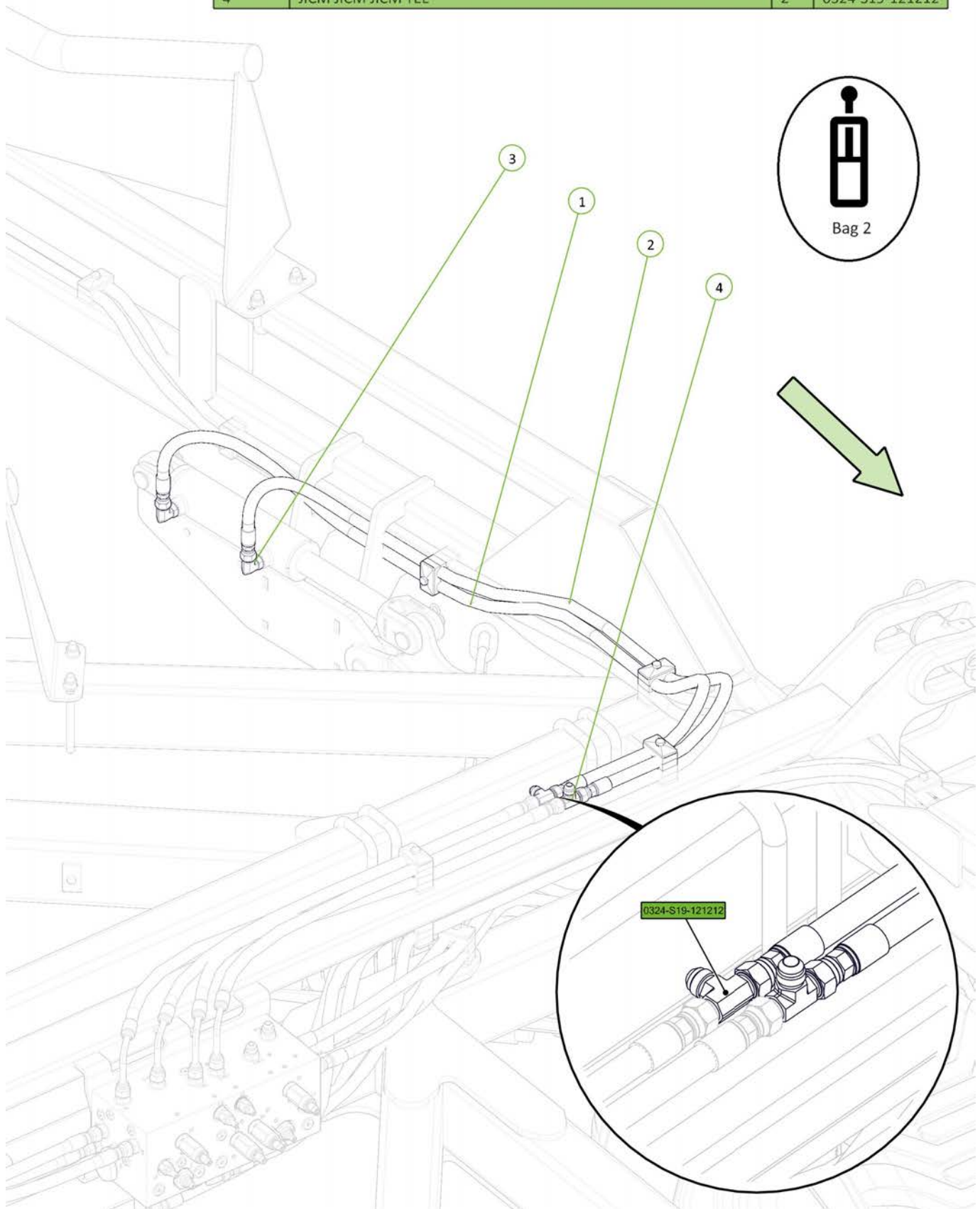

Item No.	Description	Qty	Number
1	Rear Module Extend Tee to RH Rear Module Cyl Extend Port	1	H46-15
2	Rear Module Retract Tee to RH Rear Module Cyl Retract Port	1	H46-16
3	JIC/UNO 90 Elbow	1	0323-S91-1212
4	JICM UNOM 45' ELBOW	1	0323-S88-1212

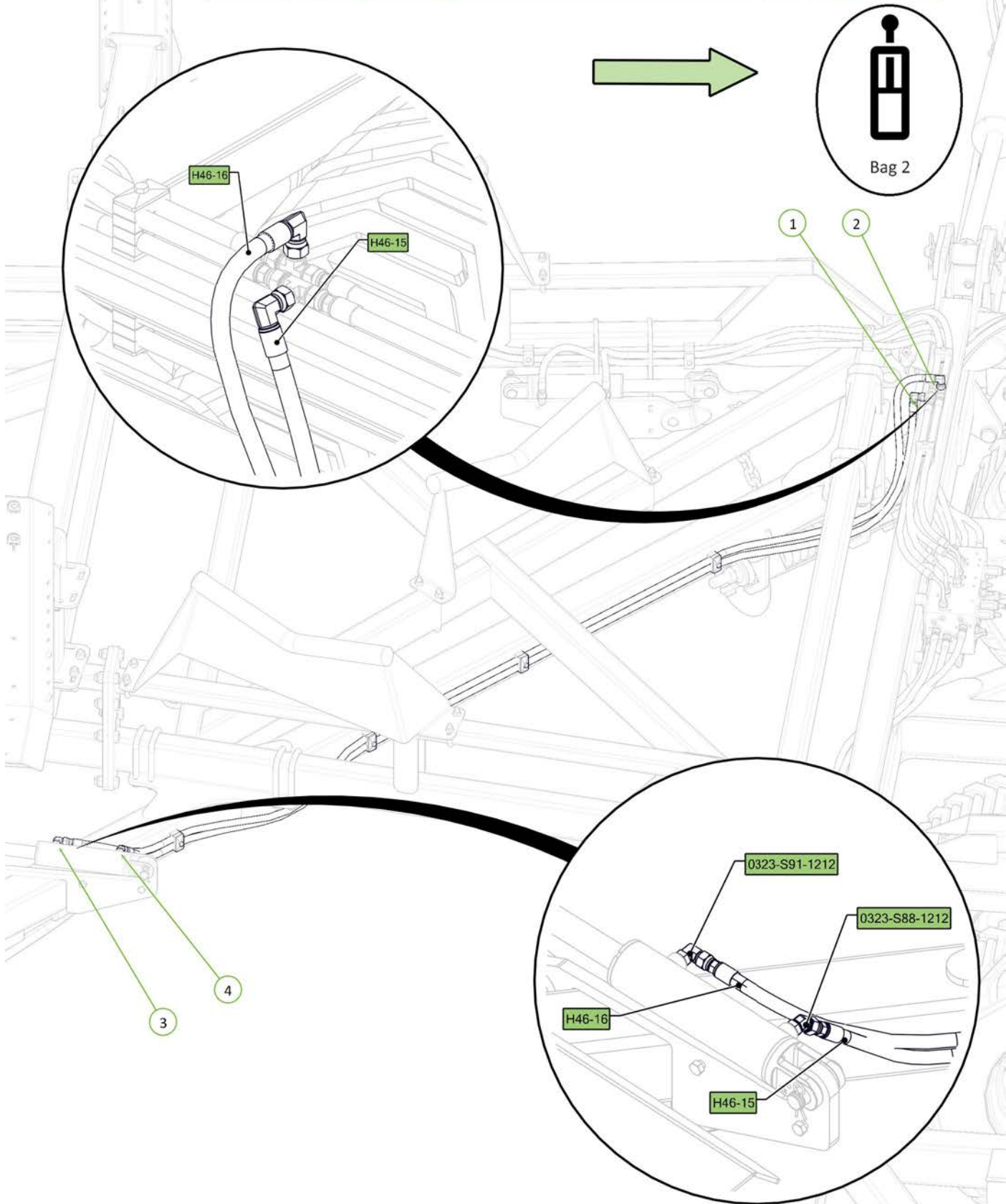

Item No.	Description	Qty	Number
1	ME3 TO FRONT MODULE EXTEND PORT	1	H46-03
2	MR3 TO FRONT MODULE RETRACT PORT	1	H46-04
3	JIC/UNO 90 Elbow	1	0323-S91-1212
4	JICM UNOM 45' ELBOW	1	0323-S88-1212

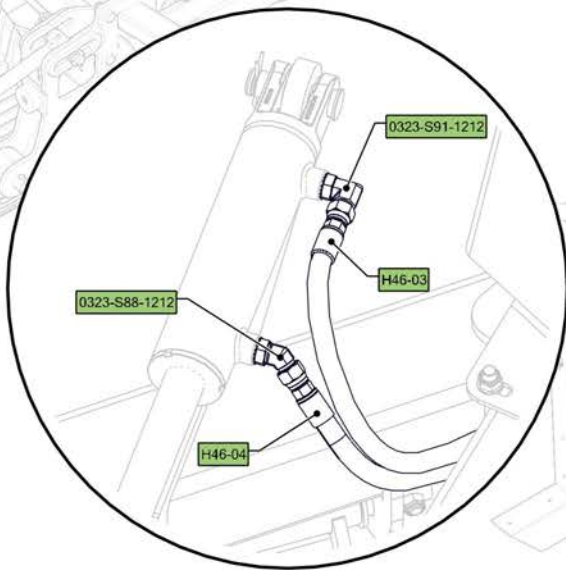
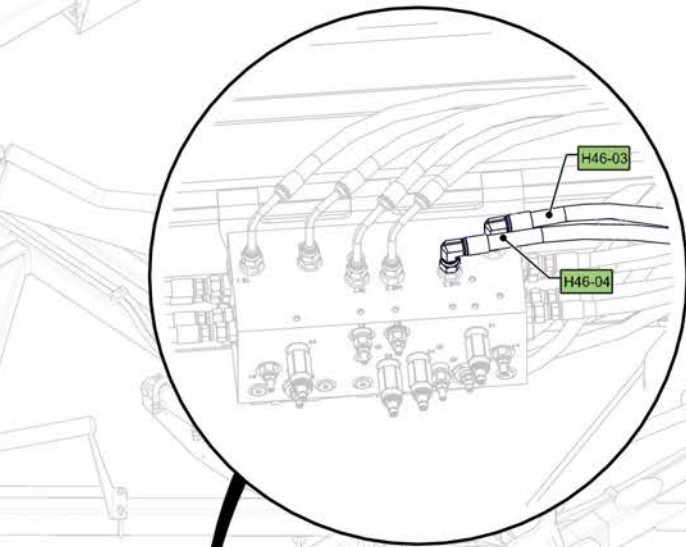
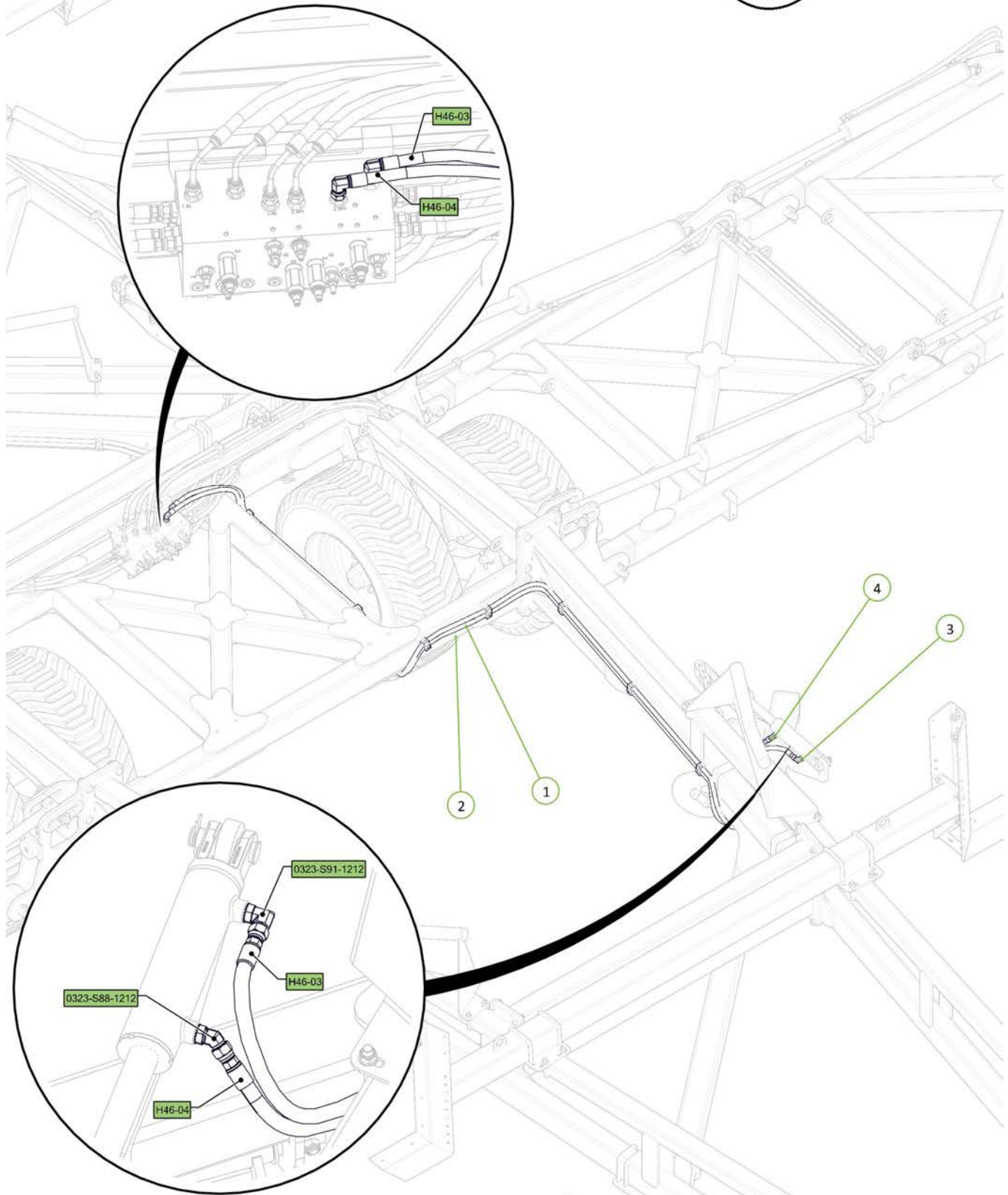



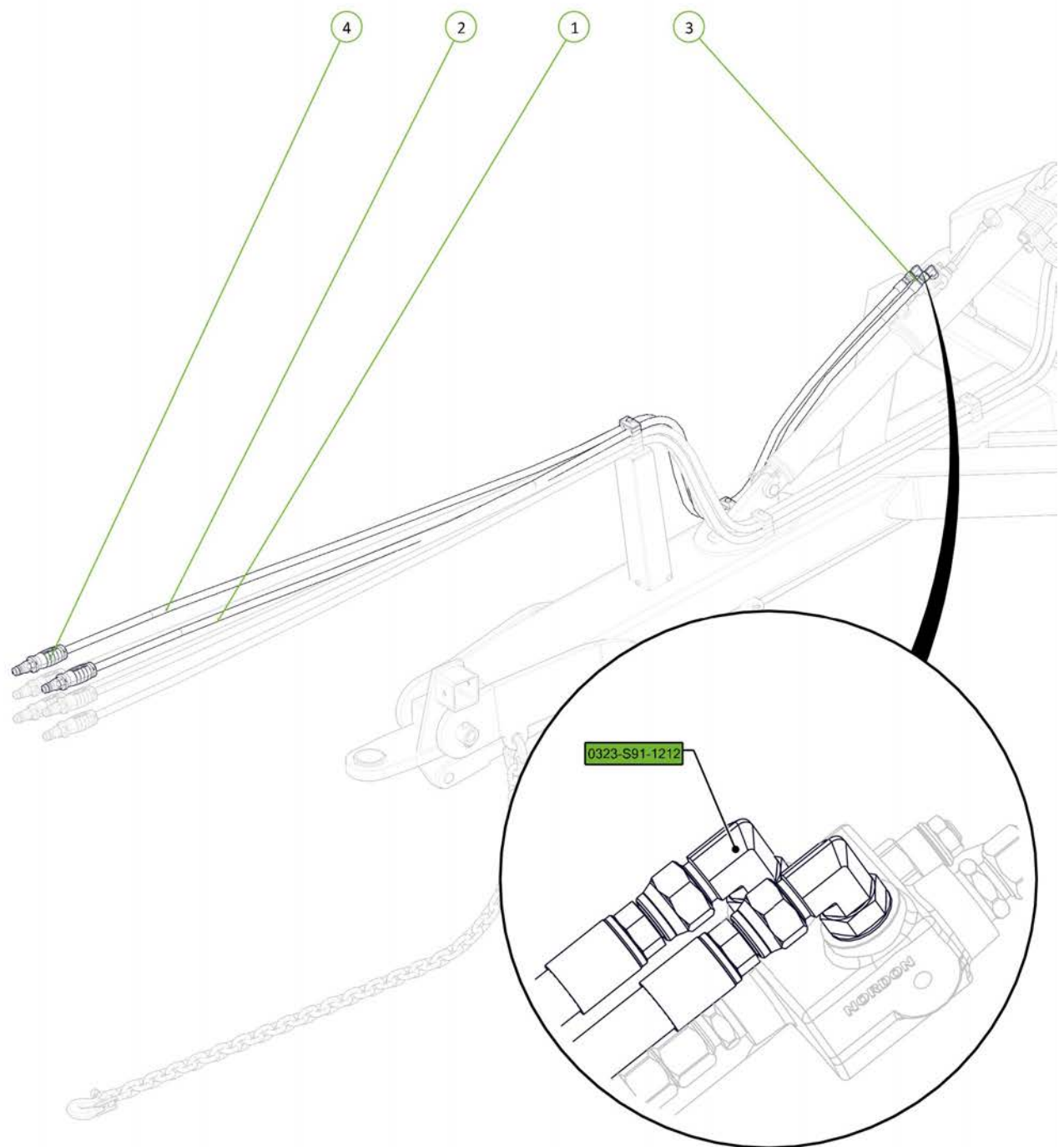
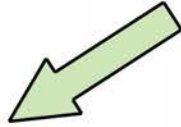





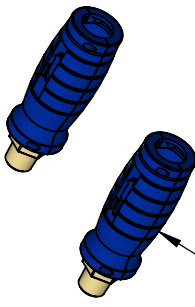
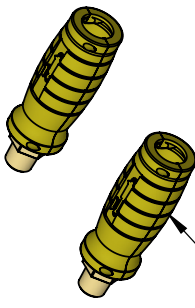
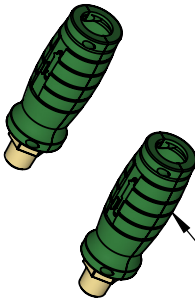

Item No.	Description	Qty	Number
1	TRACTOR TO FRONT LIFT CYLINDER RETRACT PORT FITTED WITH BLUE RET GRIP	1	H46-02-BR-RCT
2	TRACTOR TO FRONT LIFT CYLINDER EXTEND PORT FITTED WITH BLUE EXT GRIP	1	H46-02-BE-EXT
3	JIC/UNO 90 Elbow	2	0323-S91-1212
4	Blue 1/2" NPT Hydra Grip Pair (Extend/Ret)	1	0325-HG-PT20E20R





# Hydraulic Fittings

 <p><b>0325-HG-PT20E20R</b> Blue 1/2" NPT Hydra Grip Pair (Extend /Ret)</p>	 <p><b>0325-HG-PT25E25R</b> Yellow 1/2" NPT Hydra Grip Pair (Extend /Ret)</p>	 <p><b>0325-HG-PT24E25R</b> Green 1/2" NPT Hydra Grip Pair (Extend /Ret)</p>	 <p><b>0343-924001261</b> 1/2" BSPP 60 micron inline filter max flow 60L/M &amp; 5000psi max pressure</p>	 <p><b>0323-S91-1212</b> 3/4" JIC Male - 3/4" UNO Male 90° Elbow</p>	 <p><b>0323-S88-1212</b> 3/4" JIC Male - 3/4" UNO Male 45° Elbow</p>	 <p><b>0323-S15-1212</b> 3/4" JIC Male - 3/4" JIC Female 90° Elbow</p>	 <p><b>0324-S67-121212</b> 3/4" JIC Male - 3/4" JIC Female - 3/4" JIC Tee</p>	 <p><b>0324-S19-121212</b> 3/4" JIC Male Tee</p>	 <p><b>0323-S90-1212</b> 3/4" JIC Male - 3/4" UNO Male Adaptor</p>	 <p><b>0324-S92-121212</b> 3/4" JIC Male - 3/4" JIC Female - 3/4" JIC Male Tee</p>	 <p><b>0323-S74-0812</b> 1/2" BSPP O Ring Male - 3/4" JIC Male Adaptor</p>	 <p><b>0324-S68-121212</b> 3/4" JIC Male - 3/4" JIC Female - 3/4" JIC Female Tee</p>	 <p><b>0325-R91-08M</b> 1/2" BSPP Quick Release Ball Coupling</p>	 <p><b>0323-S12-1212</b> 3/4" JIC Male - 3/4" UNO Male Extended 90° Elbow</p>	<p>Part Number</p>	<p>Description</p>	<p>For Machines Built:</p>	<p>Revision</p>
							<h2>Hydraulic Fittings Parts Information</h2>		<p>B</p>									





# Section 4

## Light Kit

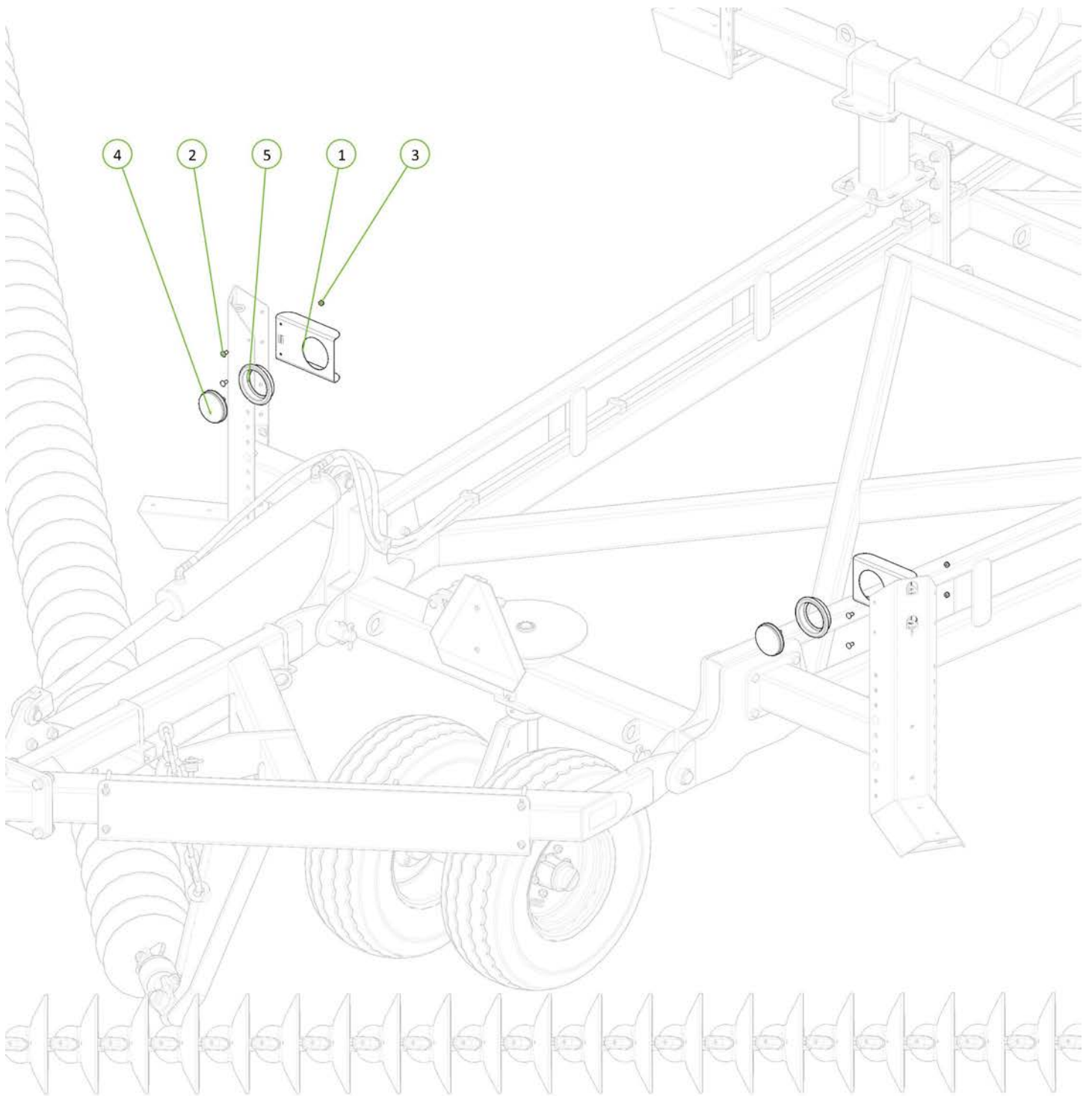

Item No.	Description	Qty	Number
1	Rear Light Bracket	2	0800-295
2	M8 x 20 Coach Head Bolt	4	0215-CH0820
3	Nyloc Nut M8	4	0221-NYL8
4	LED Stop Tail Lamp	2	0412-LED110RM
5	110RM Rubber Grommet	2	0412-53101RG



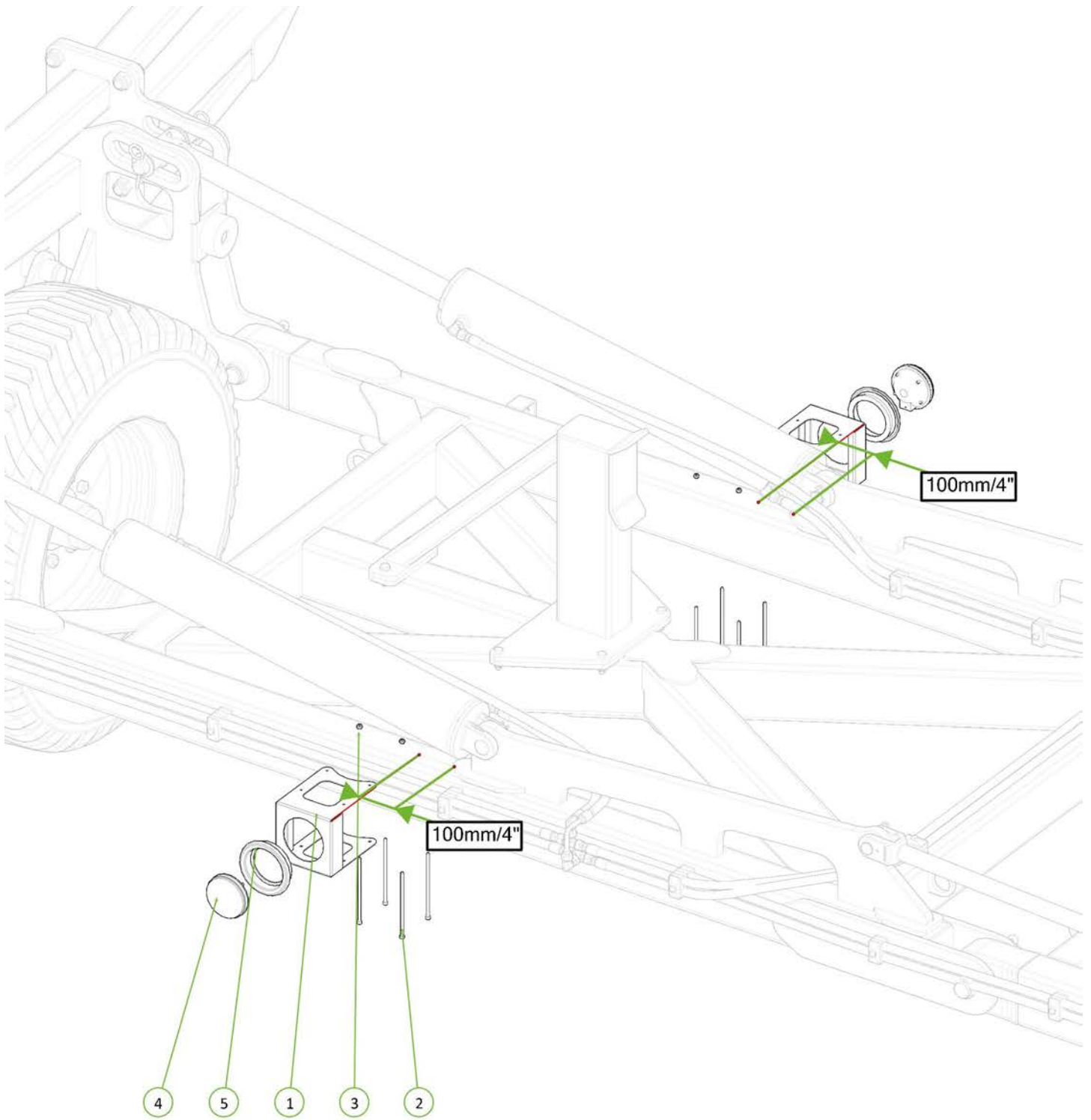

Item No.	Description	Qty	Number
1	Wing light bracket	2	0800-296
2	Socket Head Bolt M6 x 170 zp	8	0211-SH6170
3	Nyloc Nut M6	8	0221-NYL6
4	LED Rear Indicator Lamp	2	0412-LED110AM
5	110RM Rubber Grommet	2	0412-53101RG



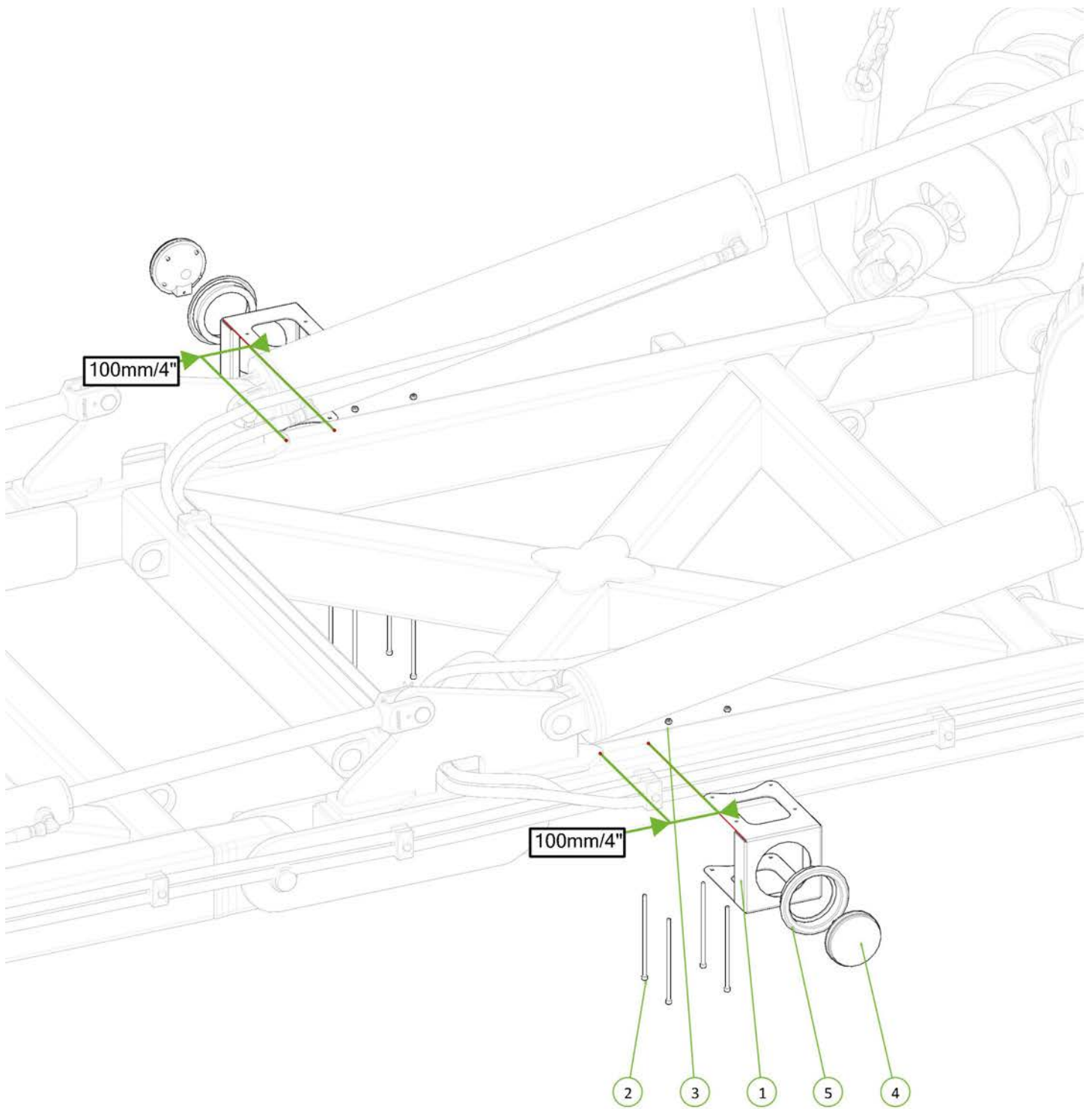

Item No.	Description	Qty	Number
1	Wing light bracket	2	0800-296
2	Socket Head Bolt M6 x 170 zp	8	0211-SH6170
3	Nyloc Nut M6	8	0221-NYL6
4	LED Rear Indicator Lamp	2	0412-LED110AM
5	110RM Rubber Grommet	2	0412-53101RG

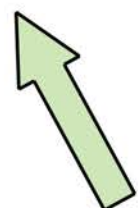

Item No.	Description	Qty	Number
1	Electrical Plug Keeper	1	0416-11750B
2	M6 x 20 Trilobe self tapping ScREW	2	0211-M620MZPHTF

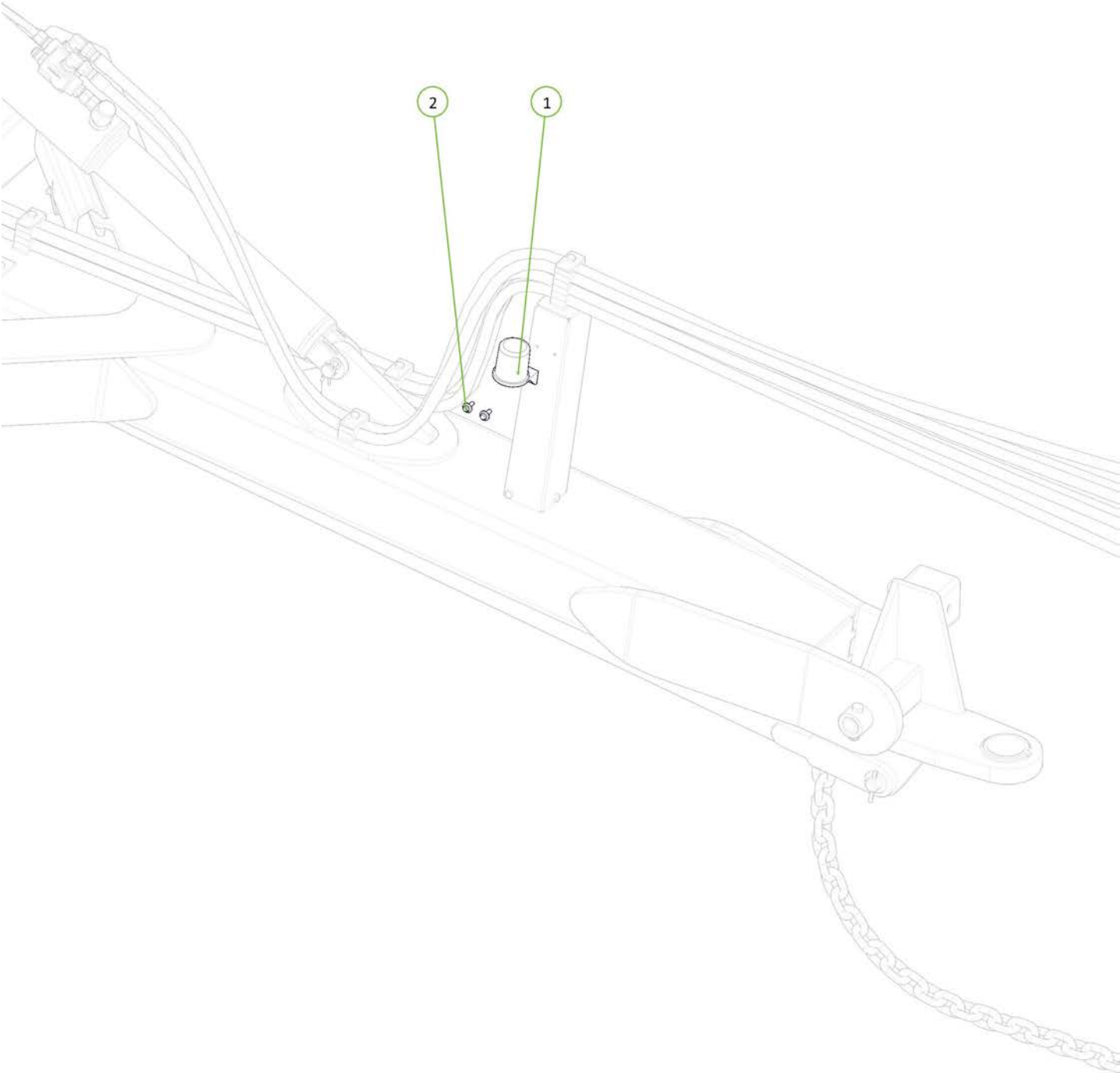
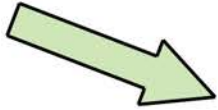

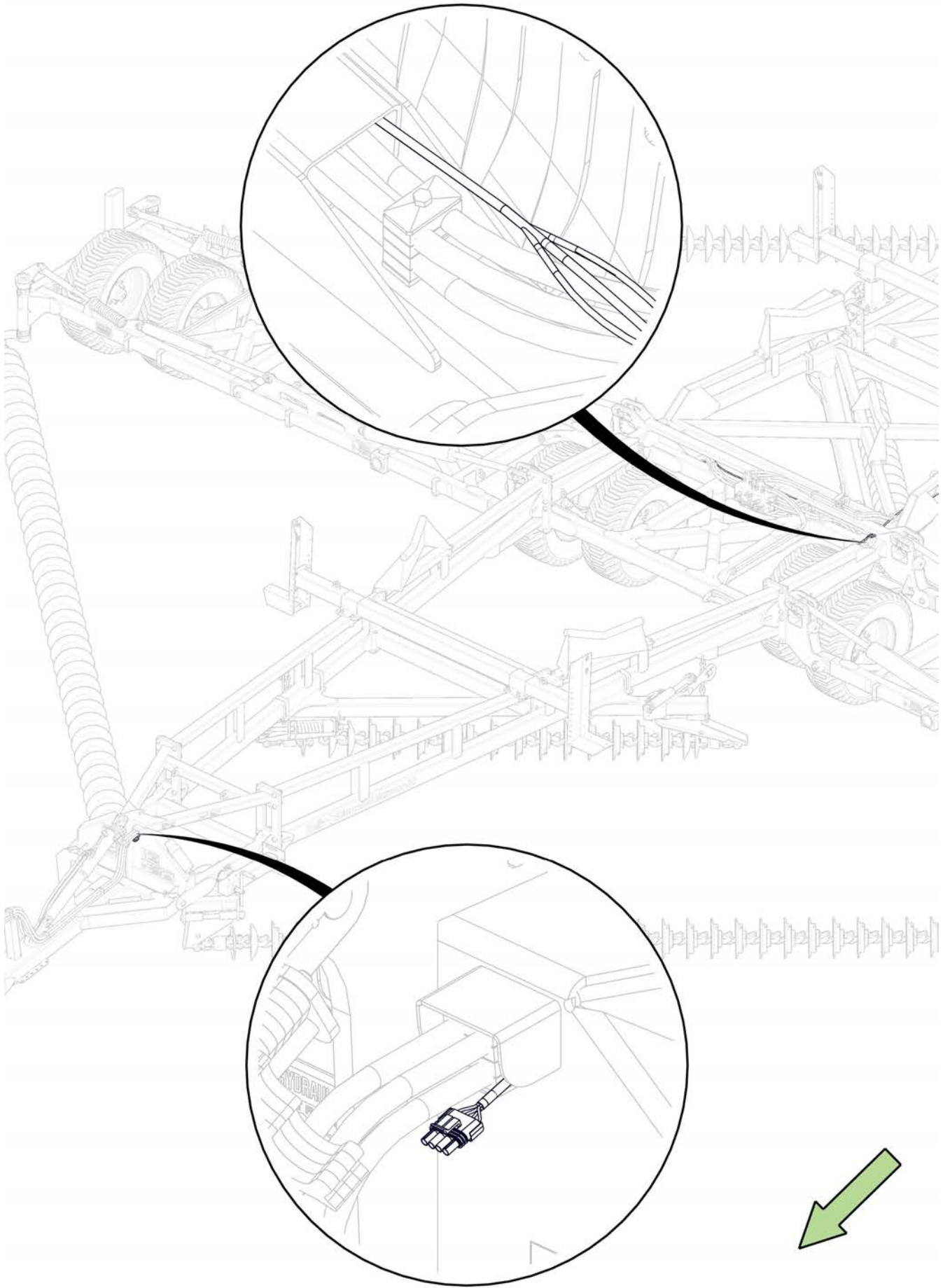

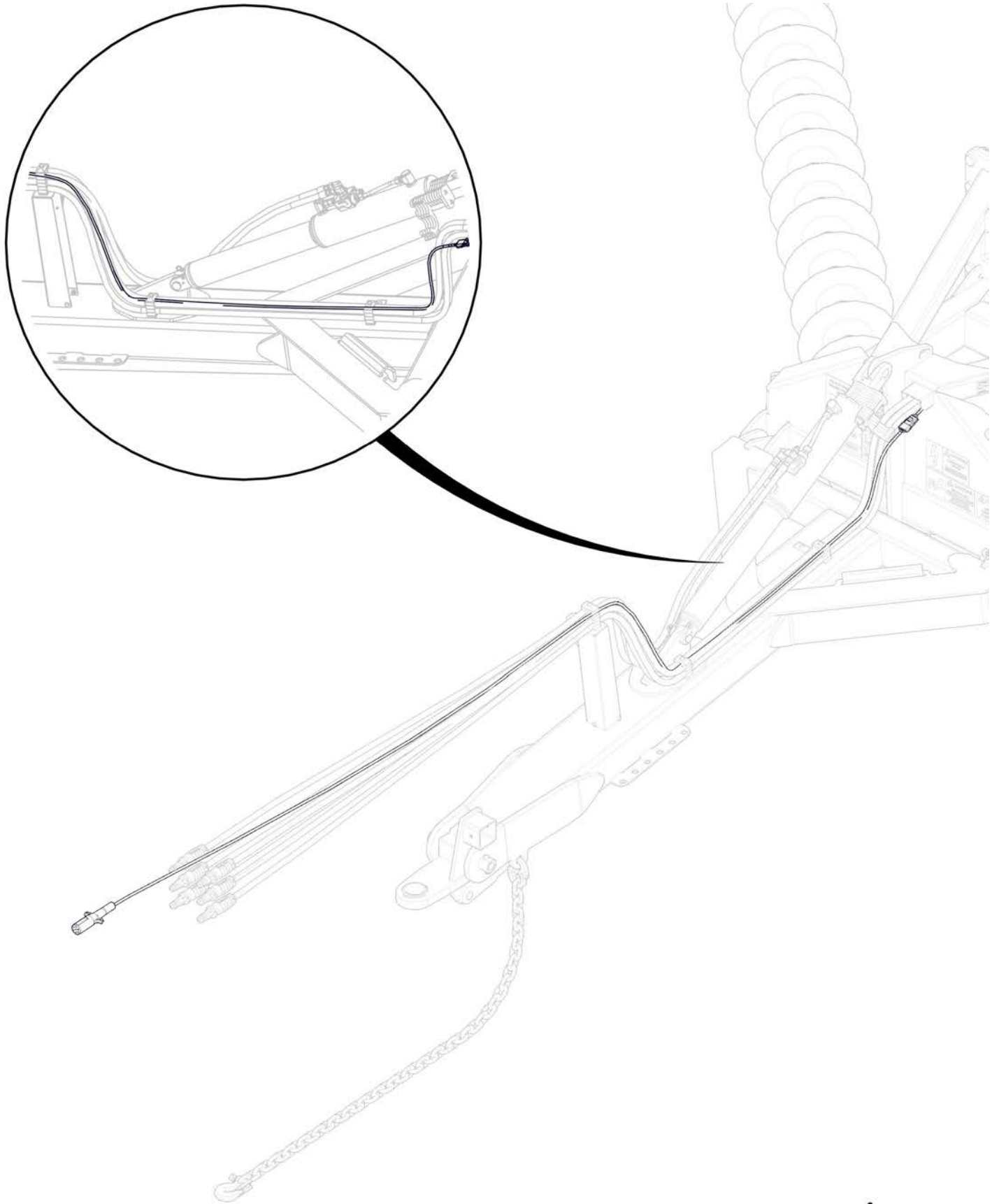

Where required secure loom to hydraulic hoses using cable ties.



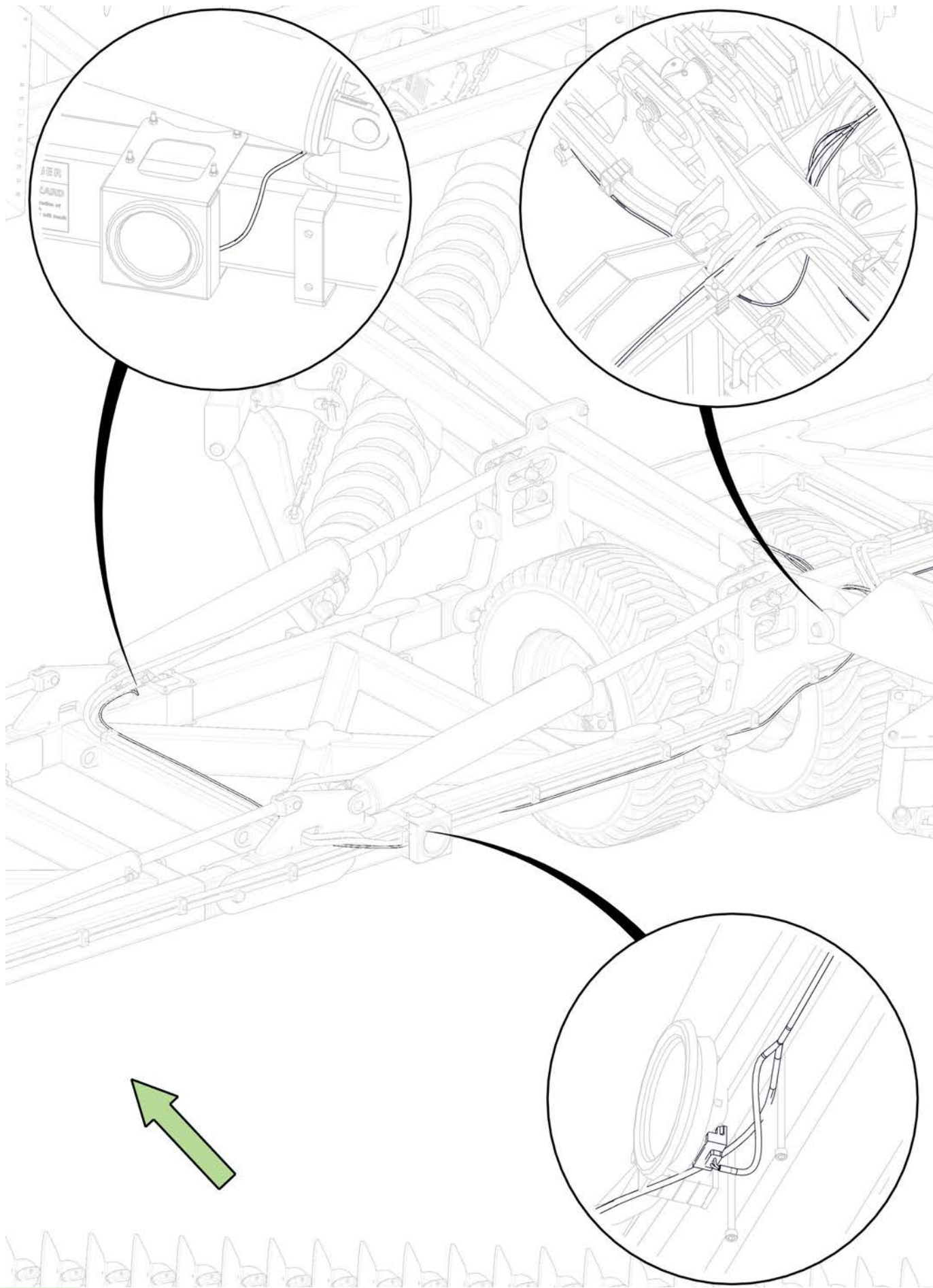



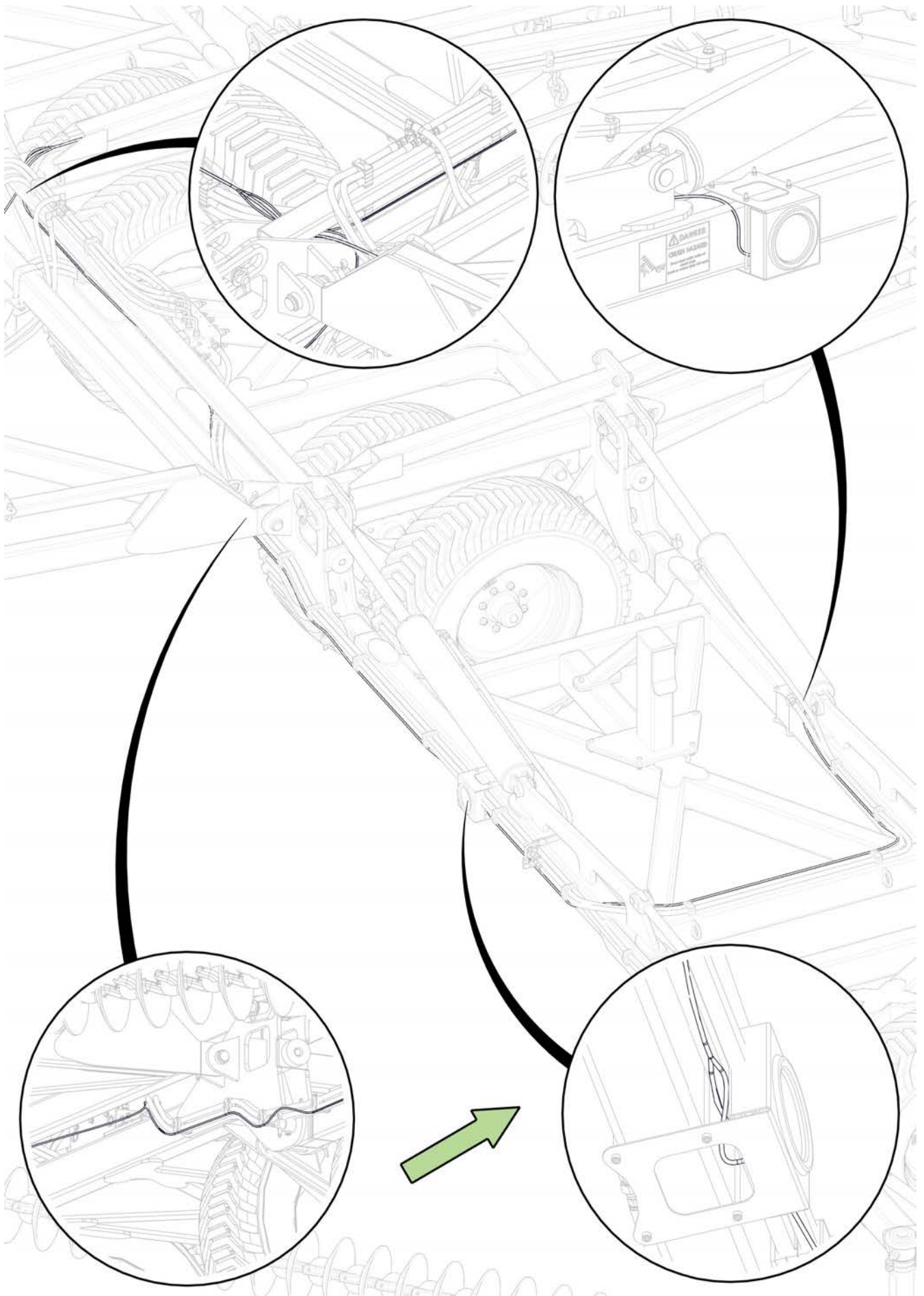

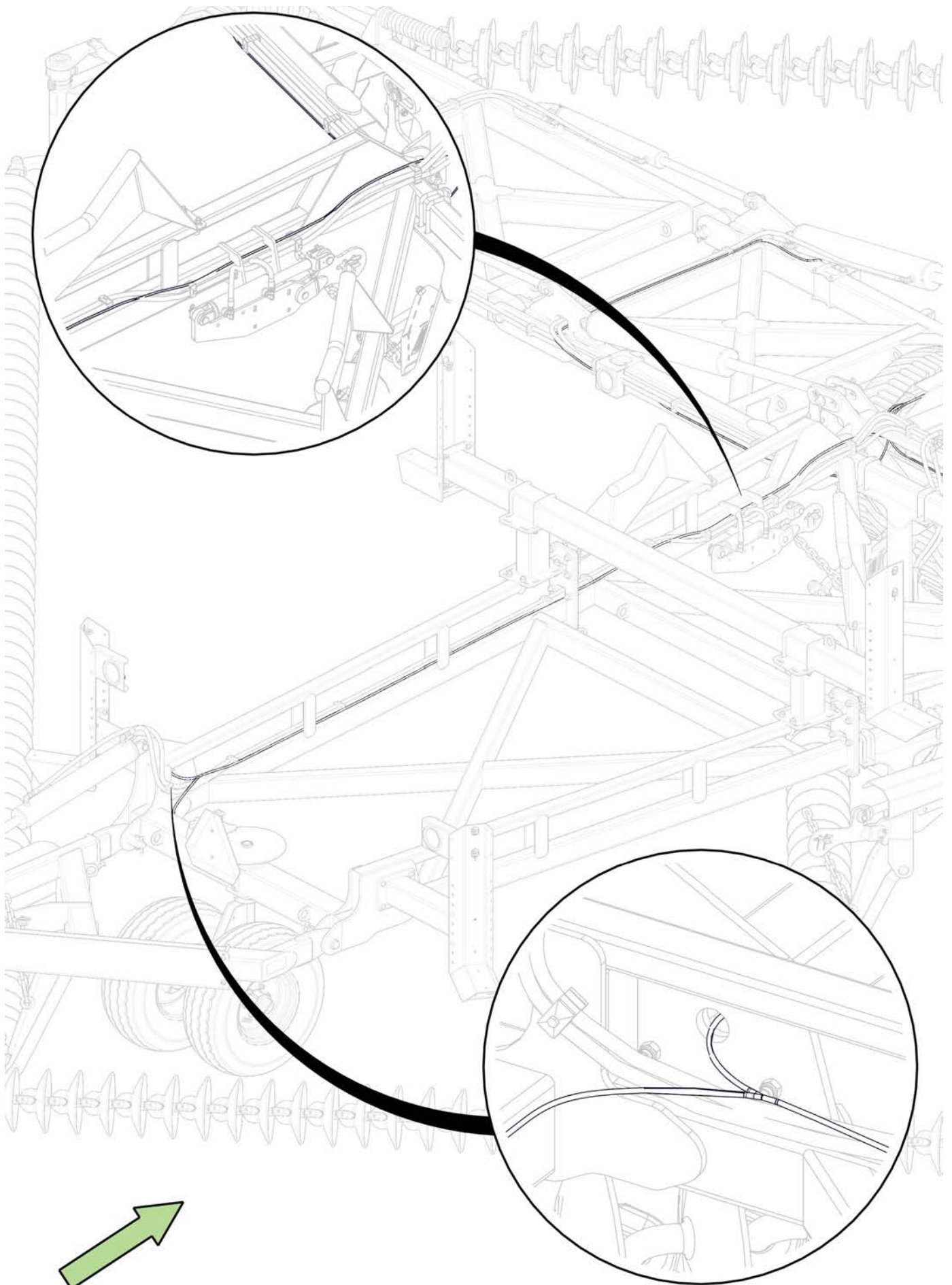

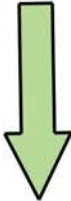
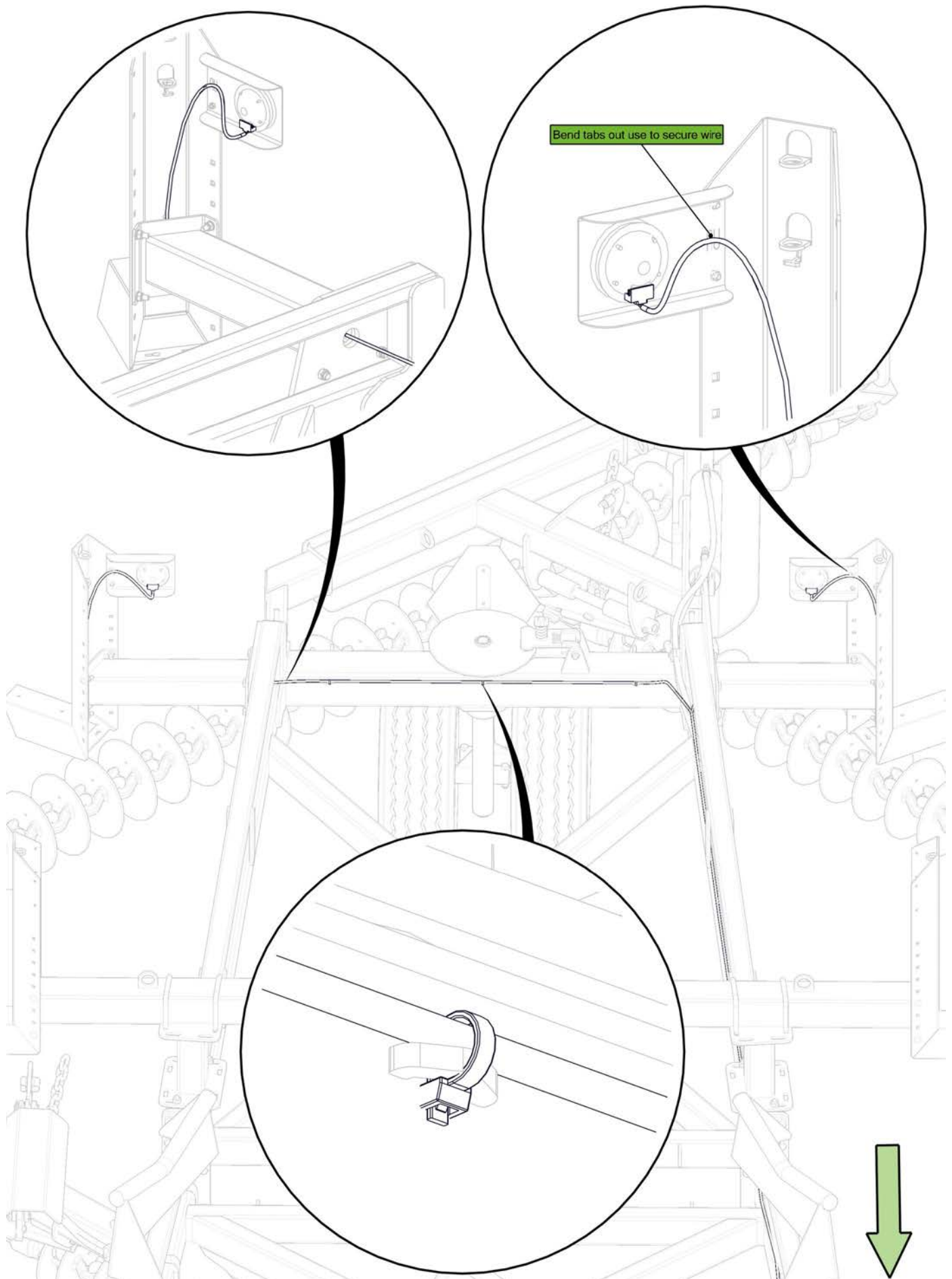

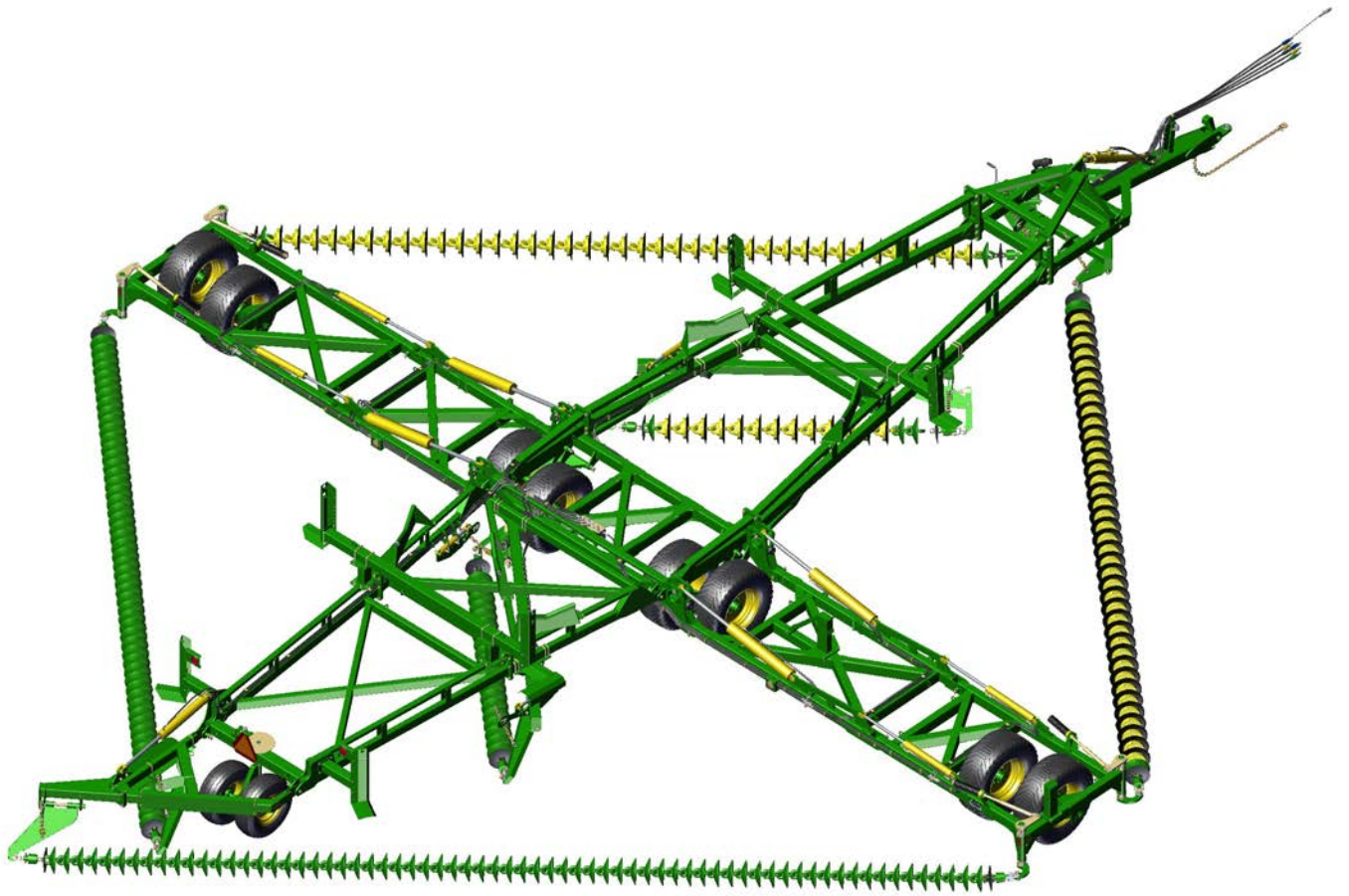

# Section 5

Diagrams & Charts

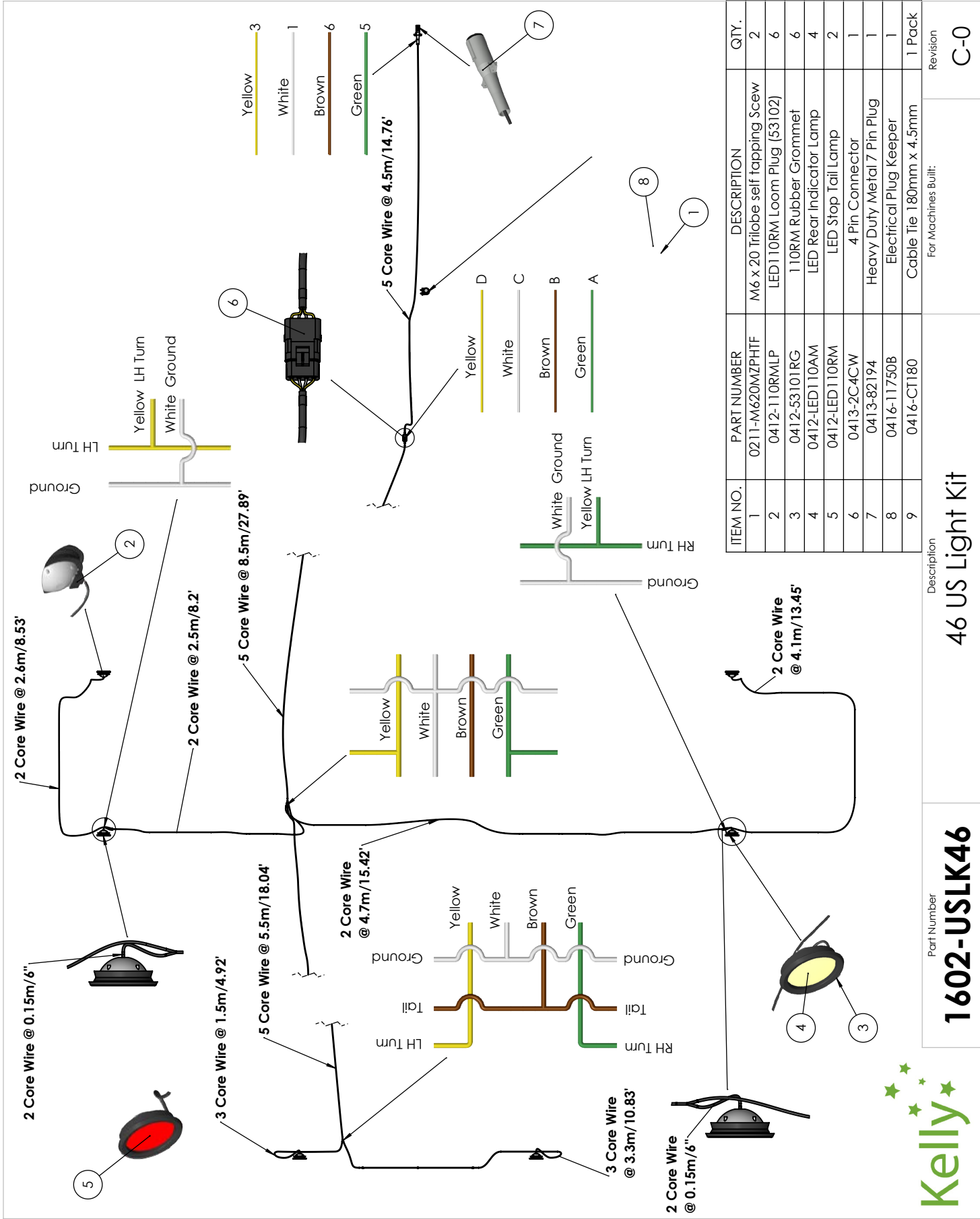

ITEM NO.	PART NUMBER	DESCRIPTION	QTY.
1	0211-M620MZPHTF	M6 x 20 Trilobe self tapping screw	2
2	0412-110RMPLP	LED 110RM Loom Plug (53102)	6
3	0412-53101RG	110RM Rubber Grommet	6
4	0412-LED110AM	LED Rear Indicator Lamp	4
5	0412-LED110RM	LED Stop Tail Lamp	2
6	0413-2C4CW	4 Pin Connector	1
7	0413-82194	Heavy Duty Metal 7 Pin Plug	1
8	0416-11750B	Electrical Plug Keeper	1
9	0416-CT180	Cable Tie 180mm x 4.5mm	1 Pack

Description

46 US Light Kit

Part Number

1602-USLK46

For Machines Built:

Revision

C-0



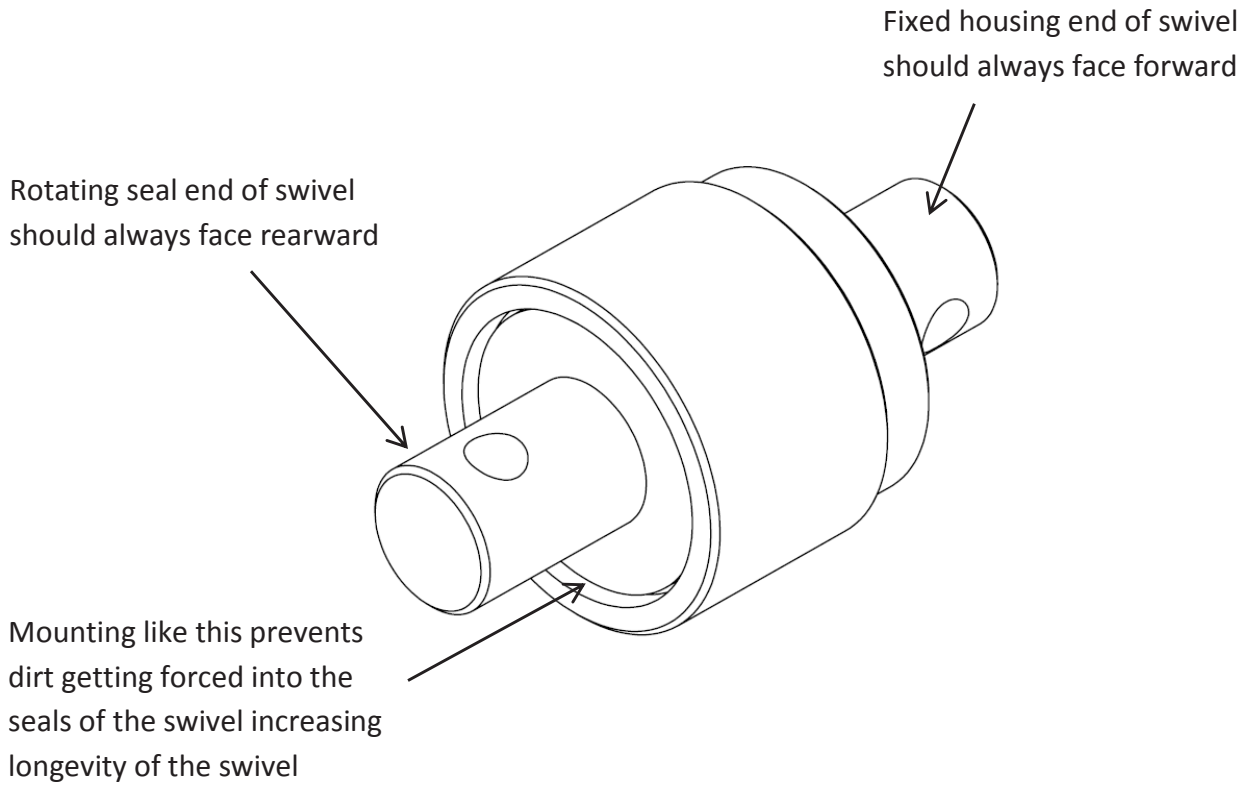

## For Example

Swivels attached to the leading ends of the chains should have the rotating seal end attached to the chain like shown

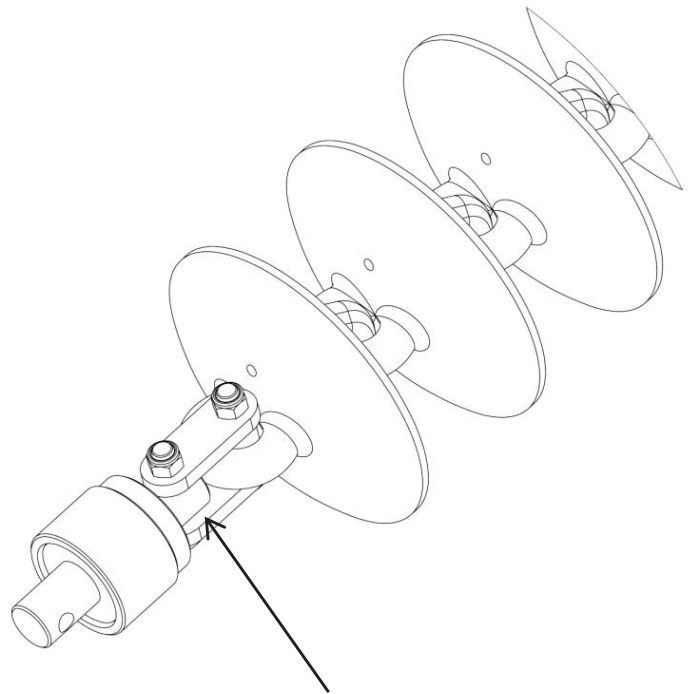
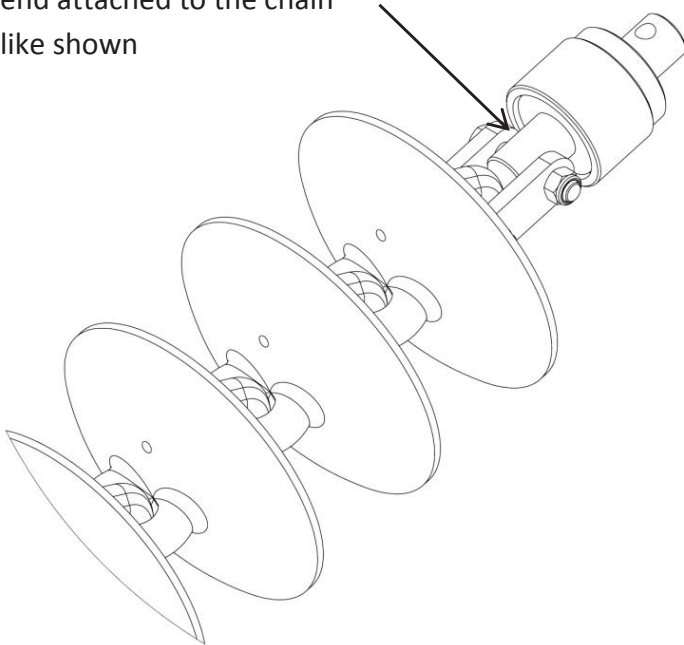

Swivels attached to the trailing ends of the chains should have the fixed housing end attached to the chain like shown

## Operating speeds

Operating speeds for normal conditions	
Chain type	Speed
Prickle Chain	6-10 Mph / 10-16 kmph
Disc Mulch Chain	6-8 Mph / 10-12 kmph
Transport / towing on roads	15 Mph / 25 kmph

## Tire pressure

Tire size	Ply	PSI	KPA
16.5L x 16.1	14	36	250
H40 x 14.5-19	26	60	410
11L - 15	10	44	300
15.5/80/24	16	58	400
16.5/85/24	16	55	380
550/60/22.5	16	40	280
400/60/22.5	16	50	350
12.5/80/18	14	85	590
15.0/70/18	14	71	490

## Chain Harrow specifications

Model	model 46
Working width	46.6'/14.2m
Transport width	13.1'/4m
Transport height	13.5'/4.1m
Transport length	57.7'/17.6m



Model		Length	CL2	CL1	W36	R300	SD49	Prickle chain
			CL2 disc chain also requires CL1 disc chain					
<b>Model 46</b>	Front right	28.47' / 8.67m	CL2 - 39 CL1 - 2	53	52	69	69	96
	Front left	28.44' / 8.67m	CL2 - 39 CL1 - 2	53	52	69	69	96
	Rear right	36.28' / 11.06m	CL2 - 40 CL1 - 16	68	67	88	88	123
	Rear left	29.26' / 8.92m	CL2 - 40 CL1 - 2	55	54	72	72	99
	Modules front	11.05' / 3.37m	CL2 - 13 CL1 - 3	20	20	27	27	37
	Modules rear	11.05' / 3.37m	CL2 - 14 CL1 - 2	20	20	27	27	37

# Section 6

Operation & Assembly Updates

## Basic Operation

### Unfolding:

1. Walk around and inspect the machine.
  - a. Check that chains are not hooked on framework
  - b. Check swivel bolts are in place and not broken
  - c. Check that height adjusting chains have not fallen out of their slotted plates during transport.
2. Lower front A frame to working height.
3. Unfold wings holding the hydraulic lever until the tail is in working position and the main center cylinder pins have centered in their slots.
4. Walk around and check that all chain links are straight and that working height of all swivels is correct for field conditions. Adjust if necessary.
5. Move off with all chains in working position. If necessary it is acceptable to raise front A pull to transport height. This will lift the front chains off the ground and reduce the load on the tractor. Lower the front A pull once moving satisfactorily.

### Folding:

1. Lower the front A frame to working height.  
(This is important to ensure that all chains locate correctly in their transport rests).
2. Fold the wings. They should move as follows; modules will raise, tail will raise, main center cylinders will retract, one or both, until the wings stand vertically. The left outer wing then the right outer wing will fold down.
3. Raise front A frame to transport height.
4. Walk around and check that chains have located correctly in transport rests.

## Setting for correct chain tension

### Wings

Use the spanner supplied. Loosen the lock nut adjacent to the tensioner assembly body.

Turn the tension bolt clockwise to compress the coil spring. Correct tension is achieved when spring retains its set length when operator rolls the chain fore and aft on the ground.

Retighten the lock nut.

See table below

### Spring Compression Length

Model	inches	mm
46	12.4	315



When less than 4" (100mm) of thread remains visible on the adjustor bolt then a link must be removed from the chain



### Modules

Loosen the lock nut on the draw bolt.

Tighten the adjusting nut clockwise until the outer face of the spring retaining washer is flush with the body of the module tensioning unit.

Retighten the lock nut.

If more than 8" (200mm) of thread is exposed then a link should be removed to maintain correct adjustment.



### Importance of chain tension

#### Operational

It is imperative that the correct adjustment be maintained. Only through correct adjustment can a smooth and level finish be achieved in field working.

Loose chains lead to :

- Uneven performance across the width of the machine
- Uneven weed control
- Unsatisfactory incorporation
- Ineffective levelling
- Accelerated or premature chain wear
- Chains failing to engage with transport locators when folded
- Machine damage when folding or unfolding
- Uneven field surface with ridges and furrows being created. The leading 1/3rd of a loose chain is much more aggressive than the trailing 1/3rd and the center. This will mean that middle of the machine's front pair of chains will aggressively move soil outwards. The machine's rear pair of chains, if loose, have their aggressive 1/3rd near the wing extremity. It follows then that as the front discs push soil outwards, the least aggressive portion of the rear chain follows them and does not balance the soil movement. This is exacerbated at the wings, effectively creating a broad ridge about halfway out each wing. It won't be evident in one pass, but is possible if care is not taken over time.

**A correctly adjusted machine will not cause this phenomenon.**

CL2 Chain Configuration

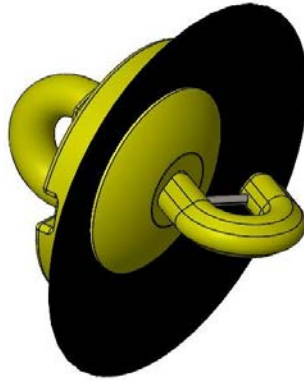

0803-CL2-Link Assembly

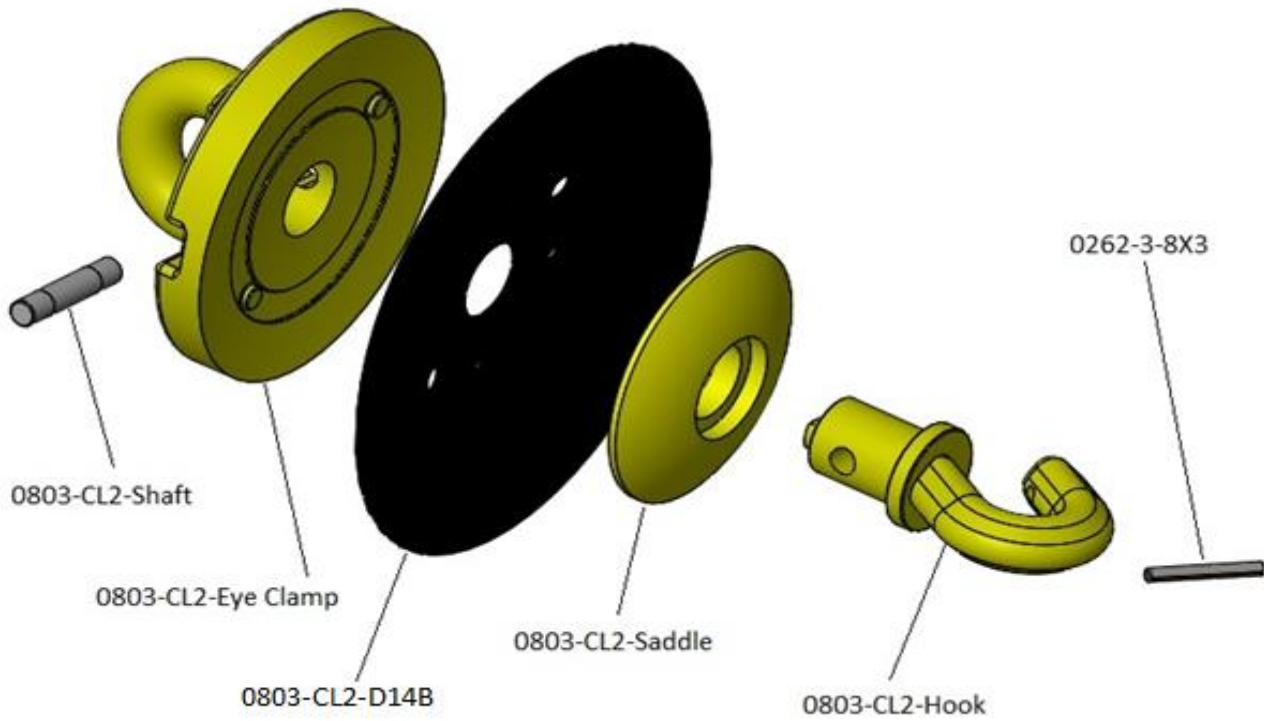

CL2 Chain Configuration

Model 46

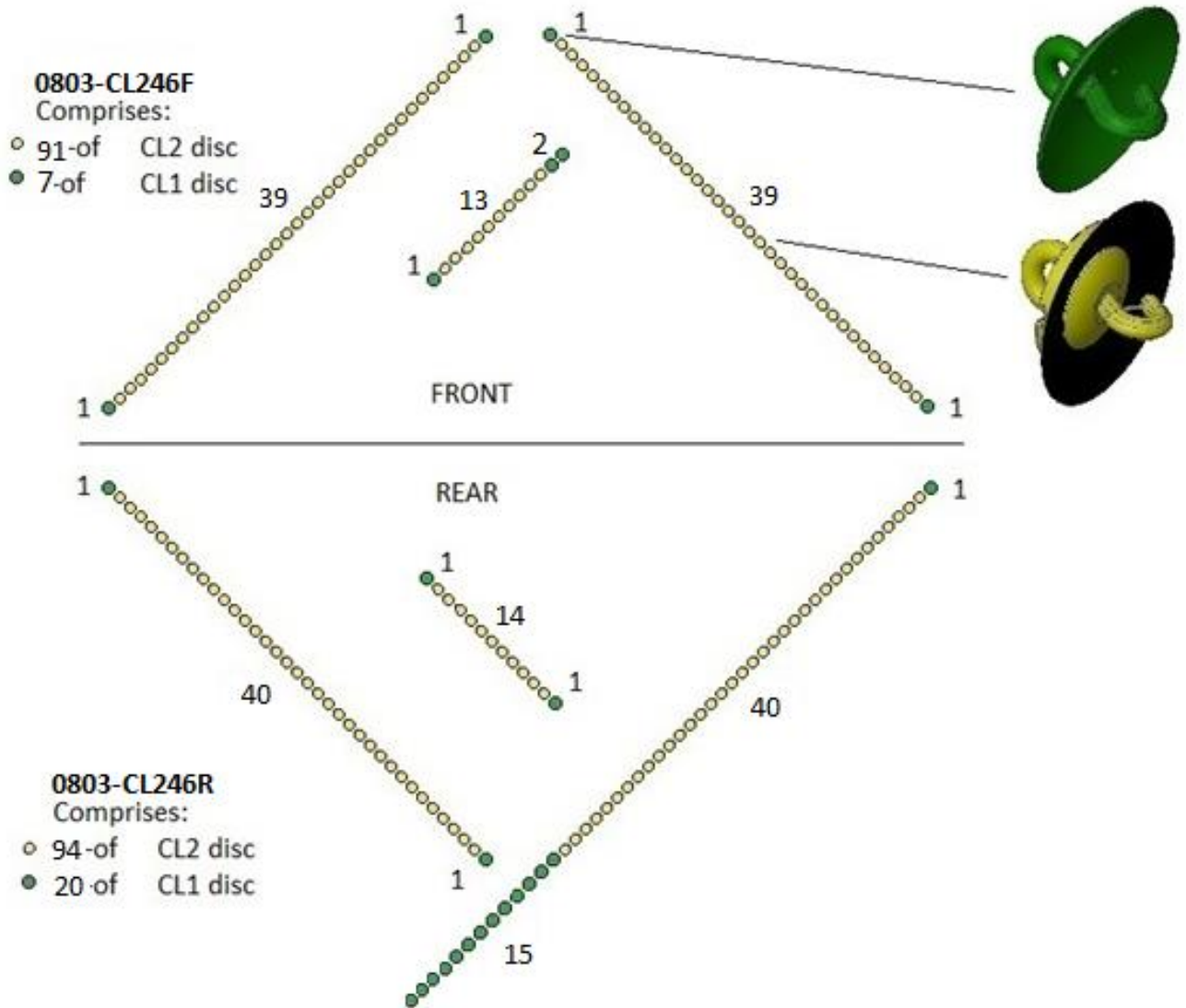

**Please Note**

Machines built from serial number 1170126 on will have 3 extra CL1 discs on the rear right chain.

## CL2 Disc Change Procedure

This document describes a procedure for the safe changeover of CL2 discs.

**NOTE: Each disc weighs 22kg (48lb). Appropriate care must be taken during manual handling**

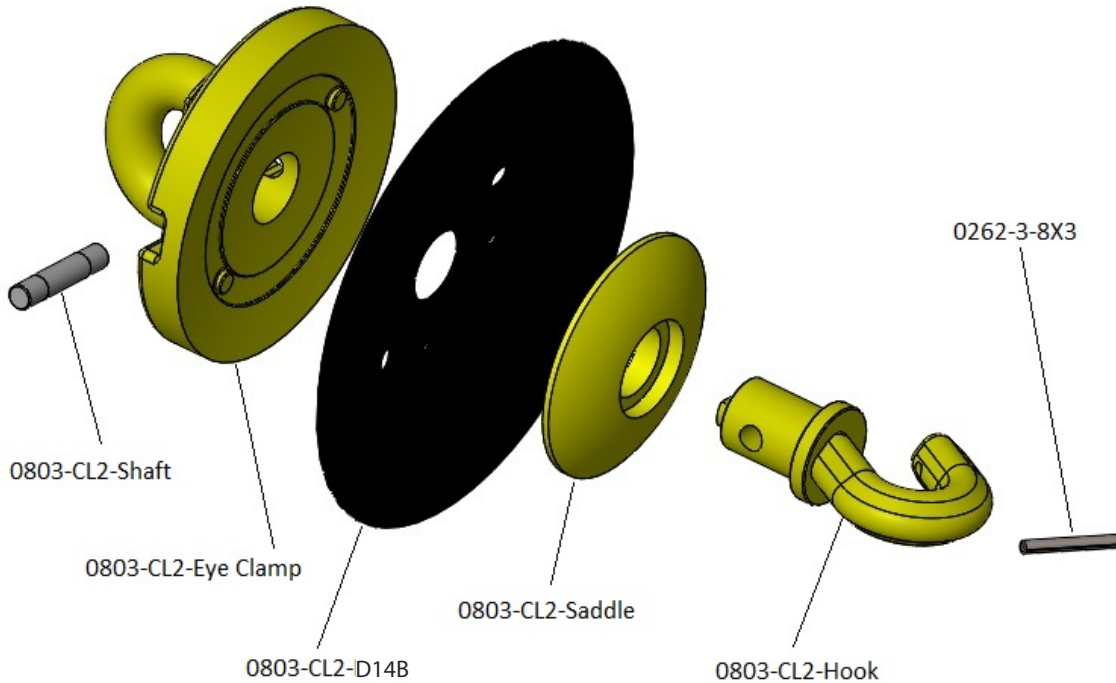

Figure 1: Exploded view of CL2 disc assembly

Changeover procedure as follows:

1. Locate press jig in press (see Figure 2 for orientation).
2. Load disc into press with Hook facing upwards - ensure that Eye Clamp and Hook are secured within the jig with pins supplied
3. Close press, applying force to Saddle (see Figure 3). DO NOT exceed pressure of 9 Tonne (19,800lb)
4. With the clamping force applied, push or tap the shaft with a hammer & drift, and remove from the CL2 Disc assembly
5. Open the press and remove the Disc from the assembly
6. Ensure that all surfaces of the castings are free from debris

## CL2 Disc Change Procedure

7. Place replacement disc on to Eye Clamp, ensuring that location holes align with casting lugs
8. Close press and re-apply clamping force. Visually confirm that Hook location hole is properly aligned with Eye Clamp location hole
9. Locate pin within hole and tap gently through both castings
10. Remove clamping force, and remove CL2 assembly from jig
11. CL2 disc is now ready for use. Repeat procedure as necessary

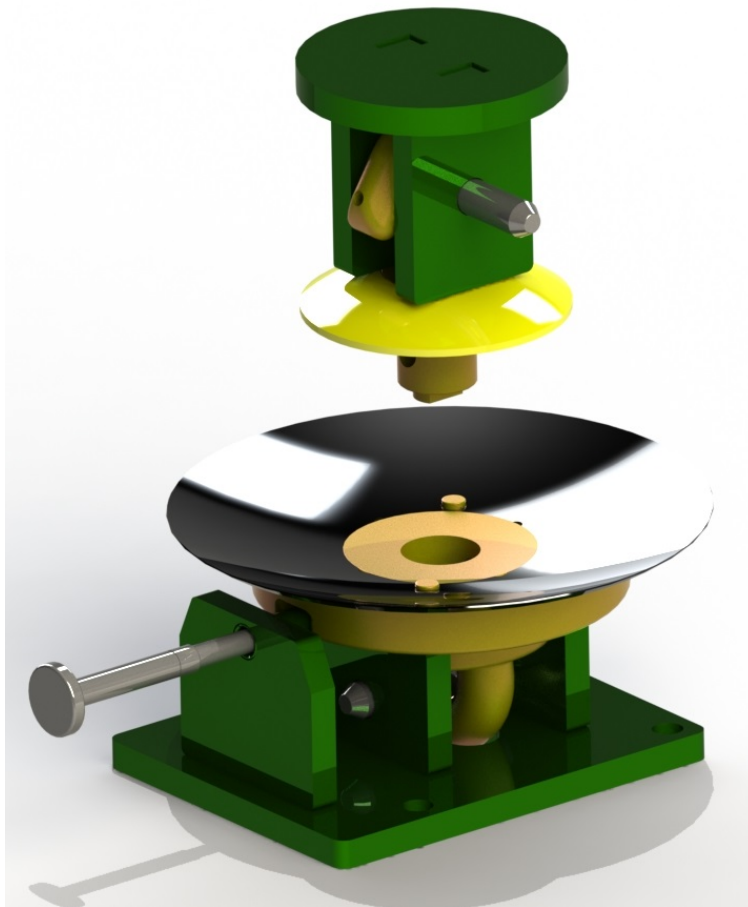

Figure 2: CL2 disc with press jig in Open position



CL2 Disc Change Procedure

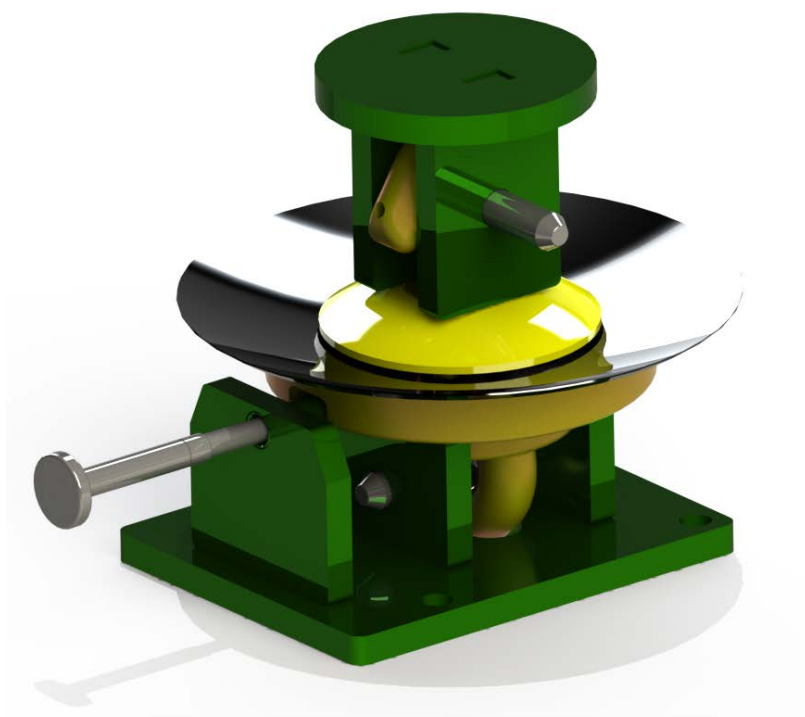

Figure 3: CL2 disc with press jig in Closed position





