

KELLY

Better Tillage. Better Tomorrow.

Assembly Manual

KELLY TILLAGE SYSTEM 3009

KEAM-R-01012025

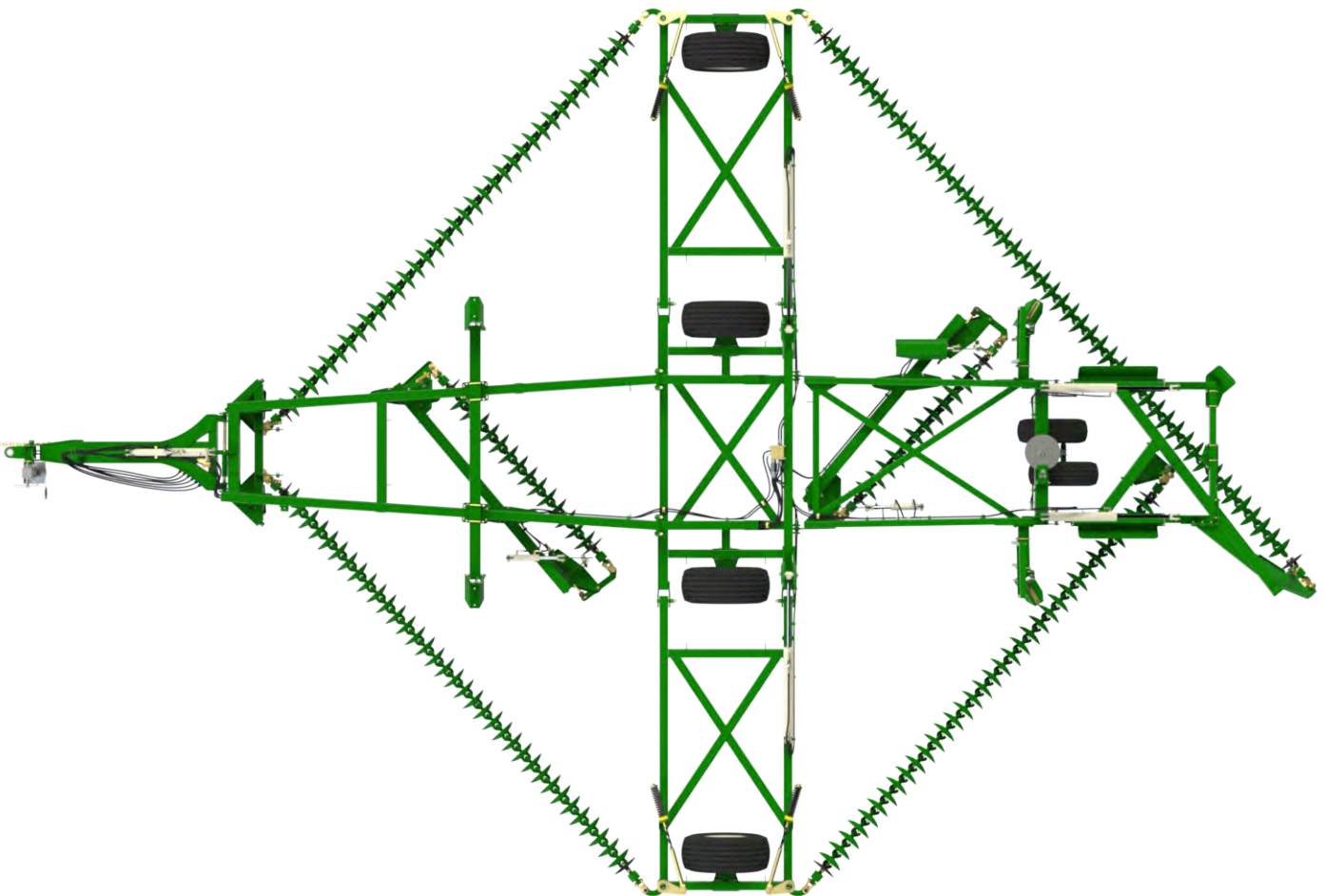

SERIAL NUMBER:

KELLY

Phone +61 8 8667 2253
Email sales@kellytillage.com
kellytillage.com

Booleroo (Head Office)
684 Kelly Road,
Booleroo Centre SA 5482

Adelaide Office
28 Greenhill Road,
Wayville SA 5034





Thank you for choosing a KELLY product.

We trust that you find the following manual clear and easy to follow. If you should require additional customer support or assistance, please do not hesitate to contact us.

Spare parts can be purchased, as required, through your local dealer or by contacting KELLY directly.

The KELLY team values your feedback. Should you have any difficulties that you wish to raise, suggestions for improvement or modifications that you feel would enhance our products we look forward to hearing from you.

Contact Us

Australia

Booleroo (Head Office)

684 Kelly Road,
Booleroo Centre SA 5482

+61 8 8667 2253

Monday - Friday
8am - 4pm ACDT

Adelaide Office

28 Greenhill Road,
Wayville SA 5034

+61 8 8667 2253

Monday - Friday
8am - 4pm ACDT

Global Locations

Eastern Canada

Leading Edge Equipment
www.leadingedgeequipment.ca

1-519-421-3223

Monday - Friday
8am - 4pm EST

Western Canada

Adair Sales & Marketing Co Inc
www.adairreps.com

1-306-773-0996

Monday - Friday
8am - 5pm CST

United States

Hood & Company

+1 417-865-2100

Monday - Friday
8am - 4pm CST

Europe

kellytillage.com

+61 8 8667 2253

Monday - Friday
8am - 4pm ACDT

Argentina

Giorgi Sa Maquinarias Agrícolas
www.giorgi.com.ar

+54 3464 493512

Monday - Friday
8am - 5pm ART

South Africa

Desmond Whitfield CC

+27 82 567 8245

Monday - Friday
8am - 4pm SAST

Contents

Section 1 - Unpacking	5
Section 2 - Parts	7
Section 3 - Decal Placement	101
Section 4 - Light Kit	117
Section 5 - Chain Assembly	126
Section 6 - Specifications	136
Section 7 - Operation	139

Legend



This symbol indicates which bag the relevant fasteners are in.



This symbol indicates which bag the relevant hydraulics are in.

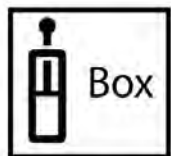

This symbol indicates the hydraulics are in a box.



This symbol indicates which way the machine is travelling.

Bolt Torque Settings

Bolt Type	Wheel nut				U Bolt			Grade 8.8 Bolt					Grade 10.9 Bolt		Grade 8 Bolt
Bolt Size	M18	M20	1/2"	9/16"	M10	M12	M16	M10	M12	M16	M20	M24	M20	M24	1" UNF
Ft lb	255	265	90	100	22	36	55	32	48	140	190	270	300	350	849
Nm	345	360	125	140	30	50	75	44	65	190	260	370	406	475	1151

[1] When fitting a wheel & tire to a hub, tighten the wheel nuts in a star pattern to the correct tension. To achieve this choose a wheel nut & tighten, then proceed to the opposite side of the hub to the next wheel nut & tighten & so on until all wheel nuts are tight. Then repeat the procedure to check that all nuts are tight. Do not use impact tools to tighten wheel nuts. For a guide to the correct tension of the wheel nuts please use the appropriate tension for your size wheel nuts from the Bolt Torque Settings table.

Torque values are for dry threads and surfaces however it is permissible to apply a small amount of anti corrosive oil to the threads.

Verification and recording of the prescribed torque settings in the table above is the responsibility of the assembler and it shall be documented in accordance with their approved Quality Assurance system

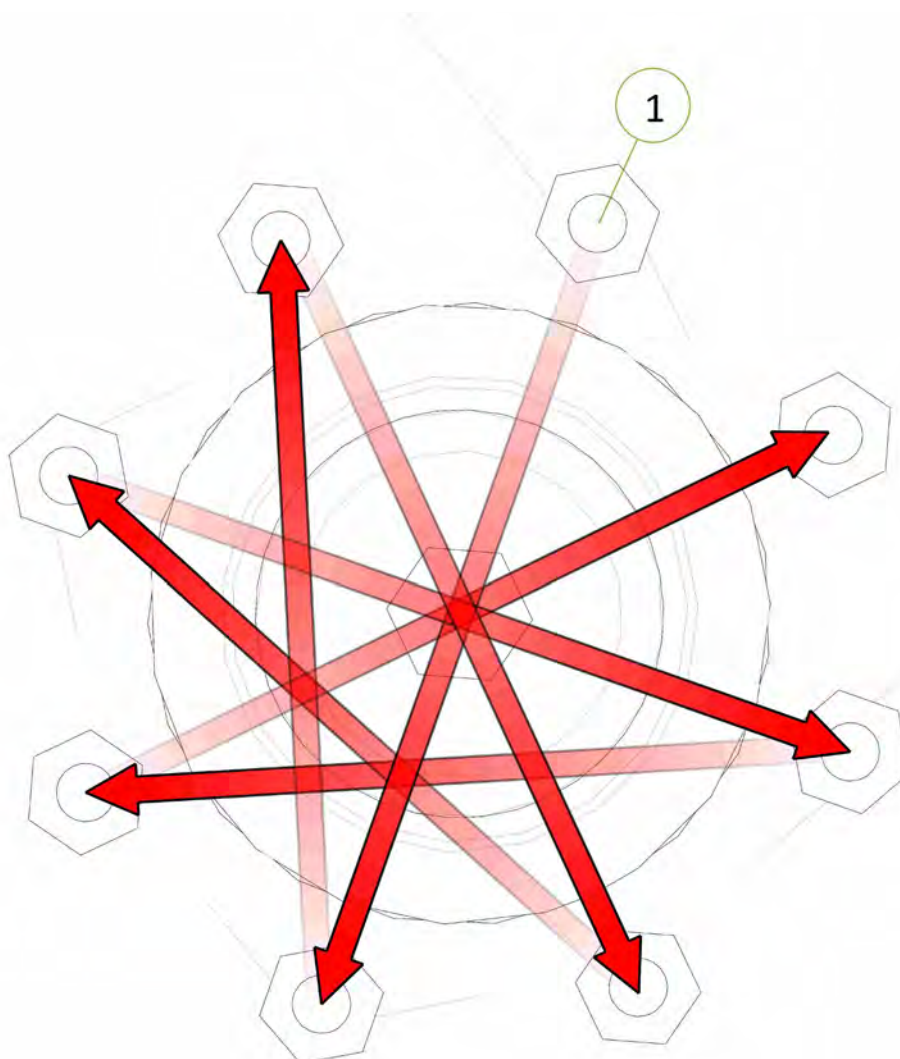



Section 1 - Unpacking

We recommend the use of suitable lifting equipment with a lifting capacity of at least 4 tones.



CAUTION

Before cutting straps attach slings or chains and take the weight of the frames to avoid them slipping or falling and causing injury.



CAUTION

Wear eye and hand protection when cutting straps. Sharp edges are exposed as straps separate and may cause injury.



CAUTION

To avoid falling or moving components, before cutting straps attach slings or chains to individual pieces and only cut the straps holding the piece to be lifted.

- Remove boxes from rear of container one at a time using a forklift truck. Each box weighs approximately 5512 lbs (2500 kg)
- Cut straps holding bundles and separate parts and place in assembly area
- Once all parts have been identified, the machine is ready for assembly
- Identify parts for each machine by serial no. or description and separate. Open parts box and check that all parts are accounted for against checklist
- Read assembly instructions before proceeding.

Keep 0801-10-08-175 pins when unpacking for machine assembly (refer to page 42)

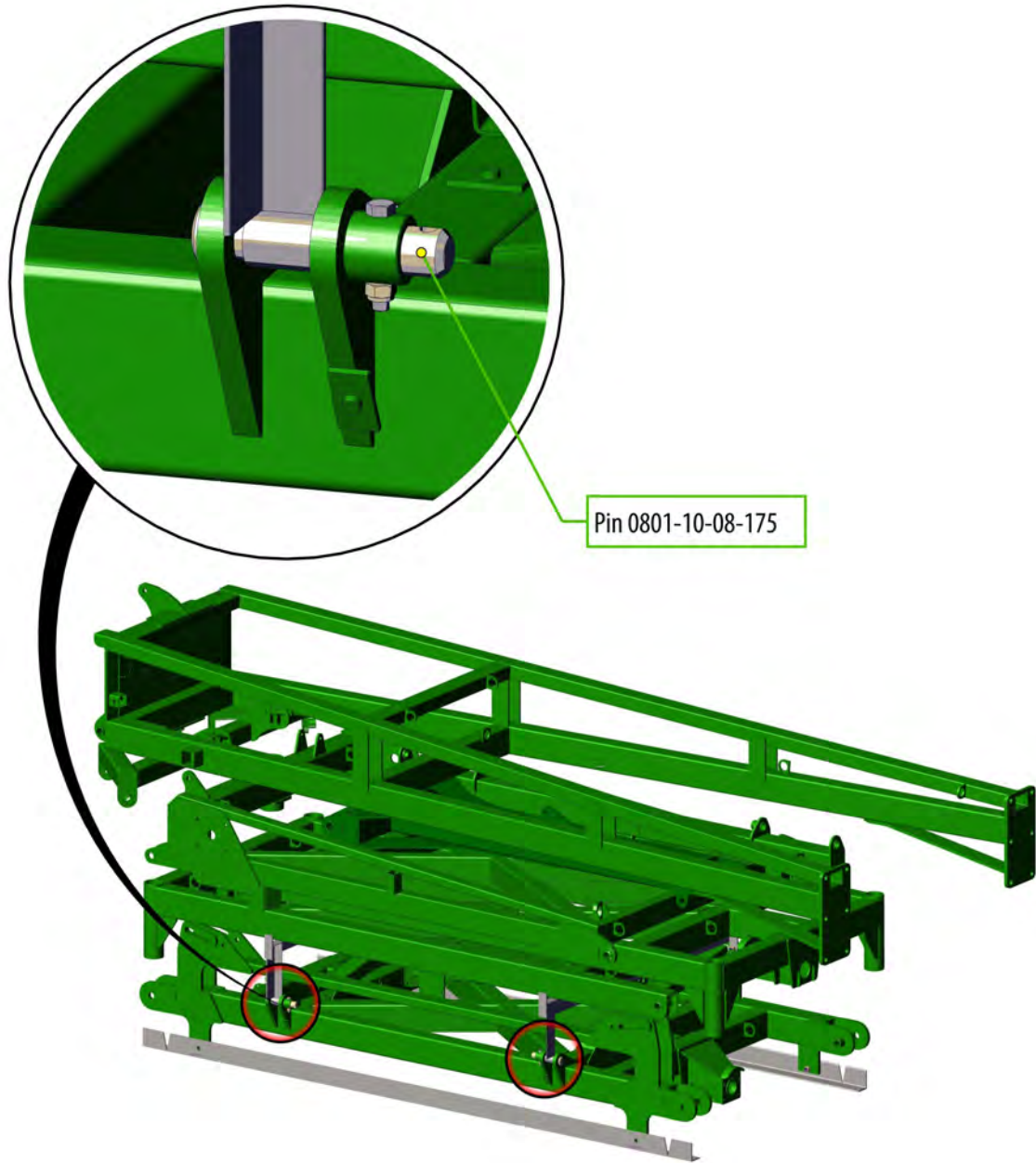

KELLY

Section 2 - PARTS

Item No.	Description	Number	Qty
1	30' Centre Frame	0830-01-2	1

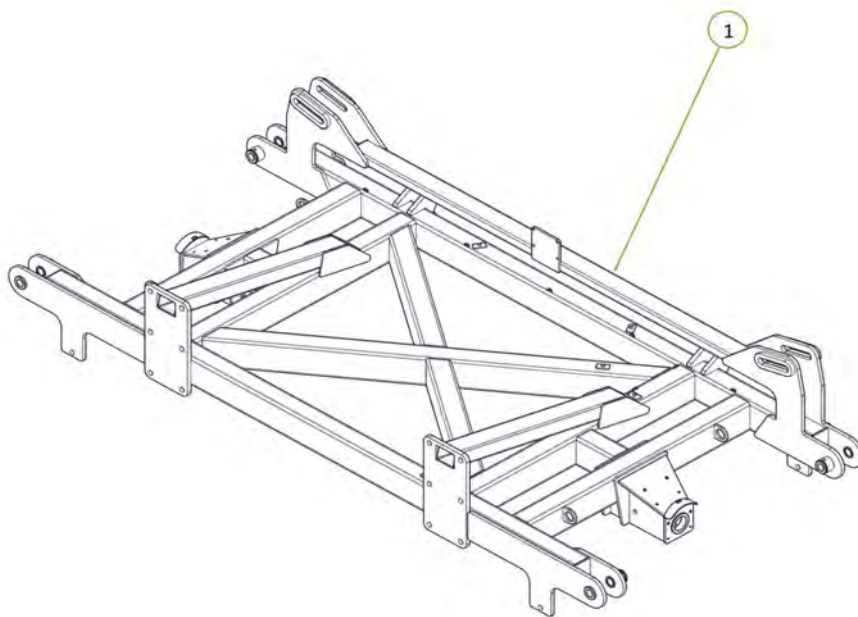

Item No.	Description	Number	Qty
1	30' Left Hand Wing	0830-07-2	1
2	PCH Wing Pivot Pin	0801-10-08-235	2
3	Cotter Pin M13 x 63	0261-PINC1363	2
4	35 ID x 30mm DU Bush	0113-MB3530DU	4
5	M12 x 90 Class 8.8 ZP Bolt	0211-1290	2
6	Nyloc Nut M12	0221-NYL12	2

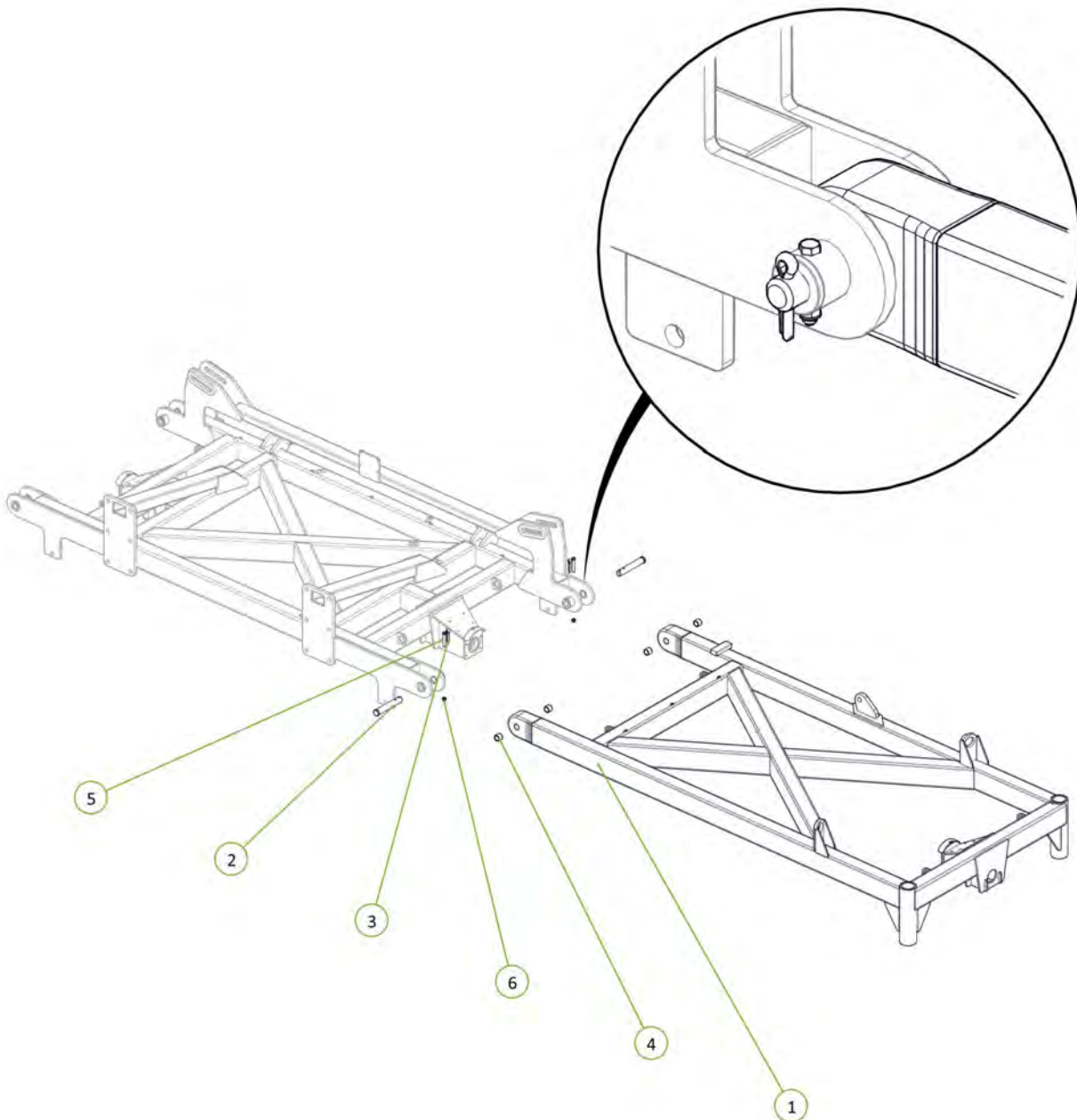

Item No.	Description	Number	Qty
1	30' Right Hand Wing	0830-06-2	1
2	PCH Wing Pivot Pin	0801-10-08-235	2
3	35 ID x 30mm DU Bush	0113-MB3530DU	4
4	Cotter Pin M13 x 63	0261-PINC1363	2
5	M12 x 90 Class 8.8 ZP Bolt	0211-1290	2
6	Nyloc Nut M12	0221-NYL12	2

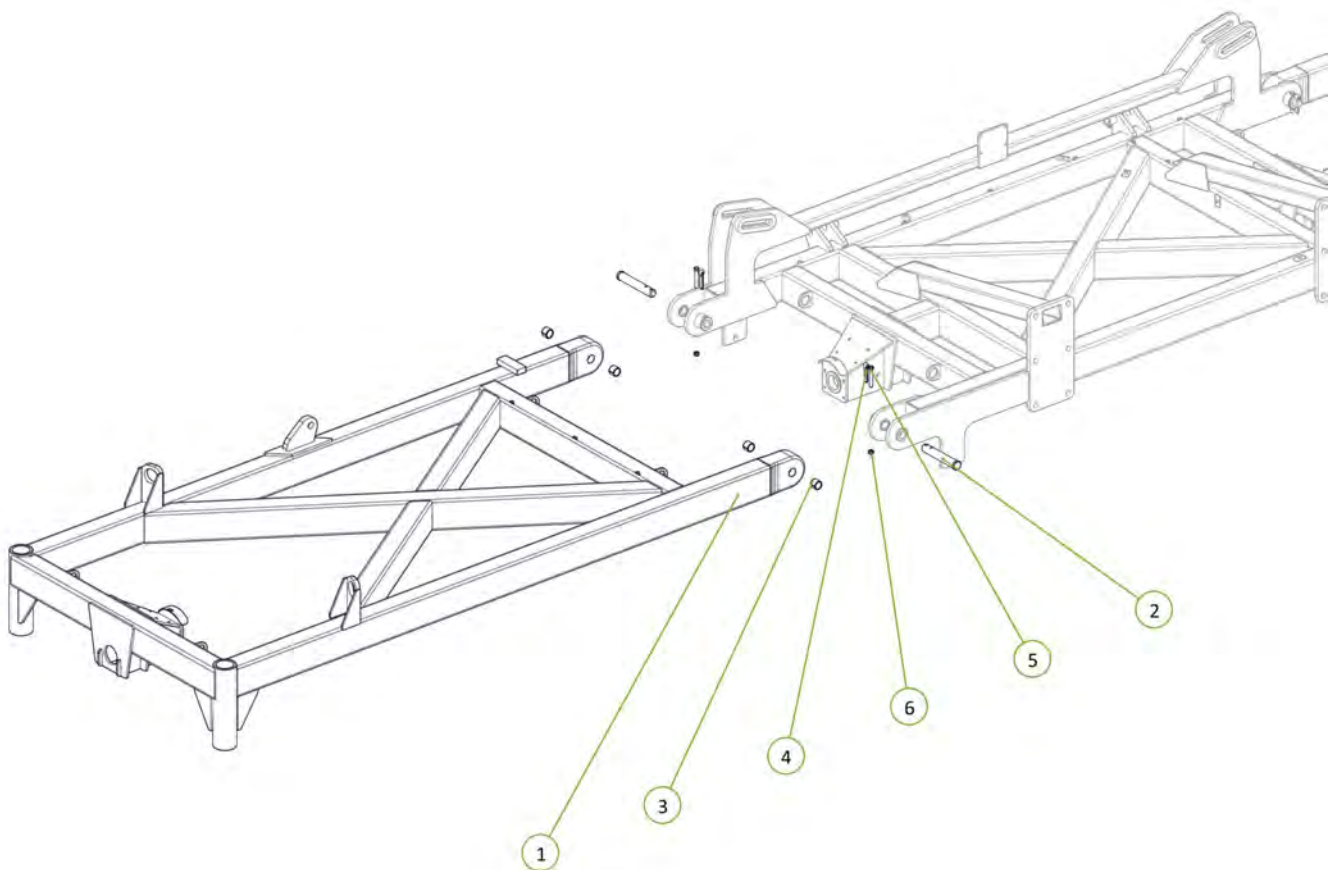

Item No.	Description	Number	Qty
1	2.75"R 6 Tonne 8 on 8" PCD Hub & Stub Complete	0733-SH27596880	4
2	M20 x 170 grade 8.8 ZP Bolt	0211-20170	4
3	Nyloc Nut M20	0221-NYL20	4
4	Washer Flat M20	0231-F20	8

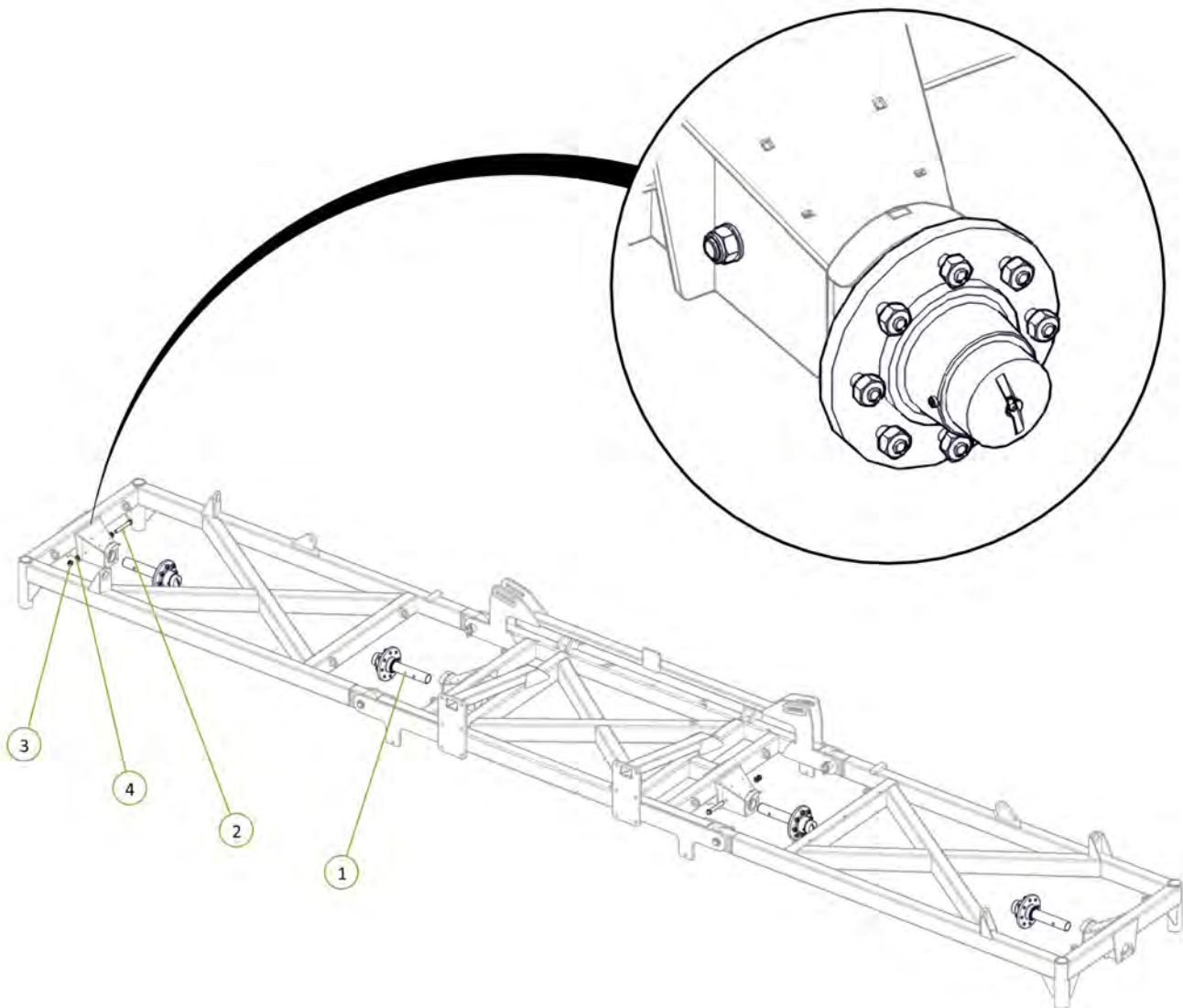

Item No.	Description	Number	Qty
1	Dual Circuit Single Sequence Block Body	0802-690507	1
2	M10 x 25 grade 8.8 ZP Bolt	0211-1025	4
3	Washer Flat M10	0231-F10	4
4	Washer Spring M10	0231-S10	4

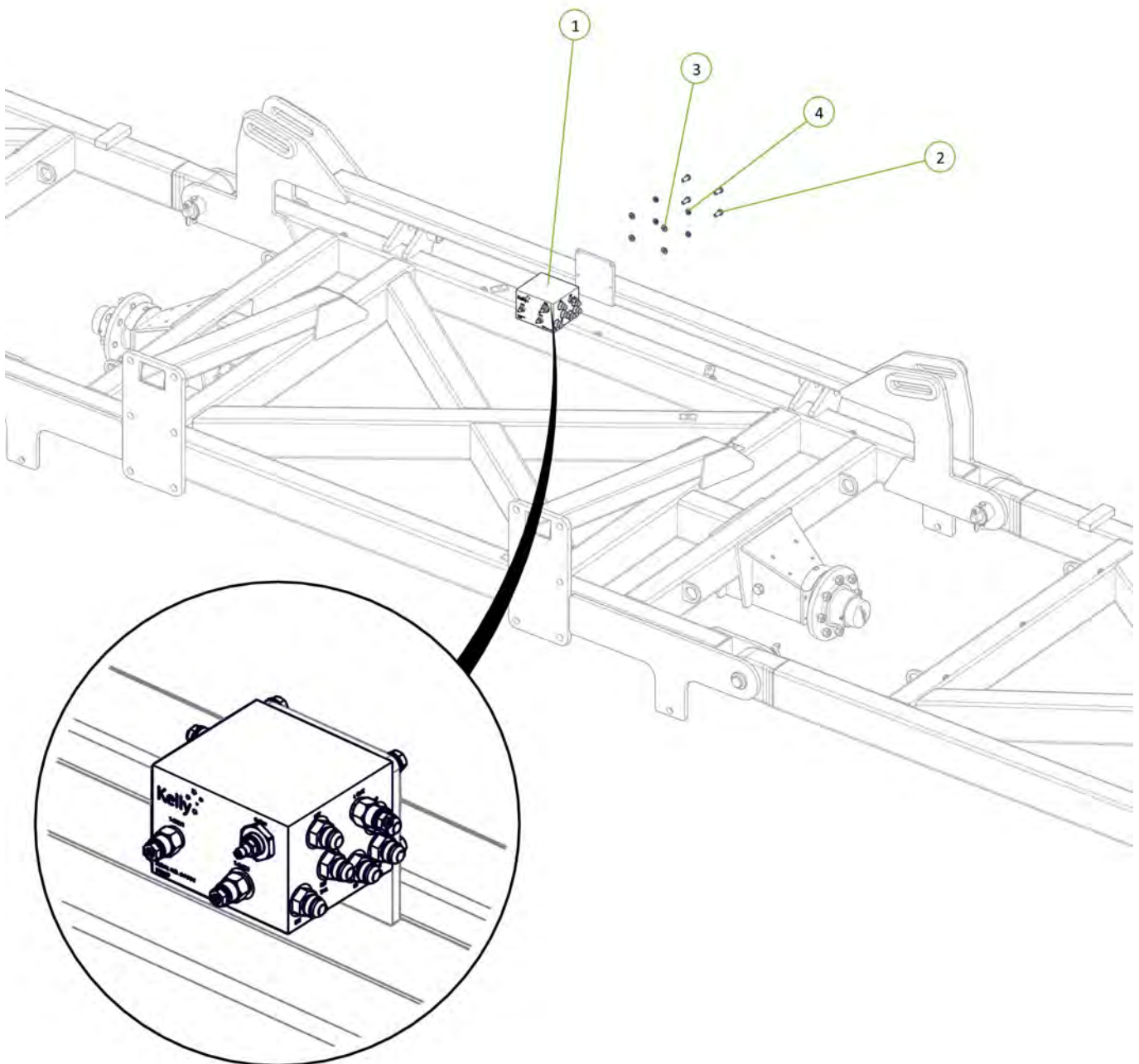

Item No.	Description	Number	Qty
1	4" Bore 30" Stroke 3" S/Tube 1.75" Rod Hydraulic Cylinder	0311-430ST	2

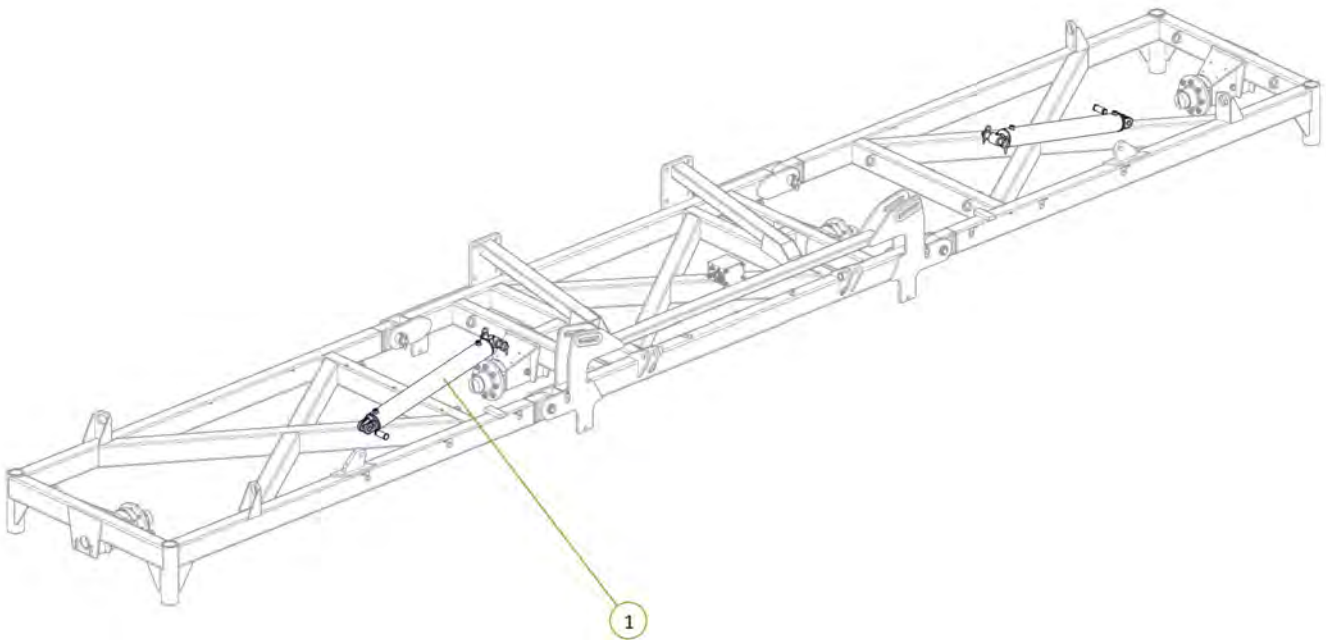
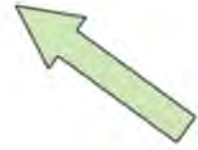

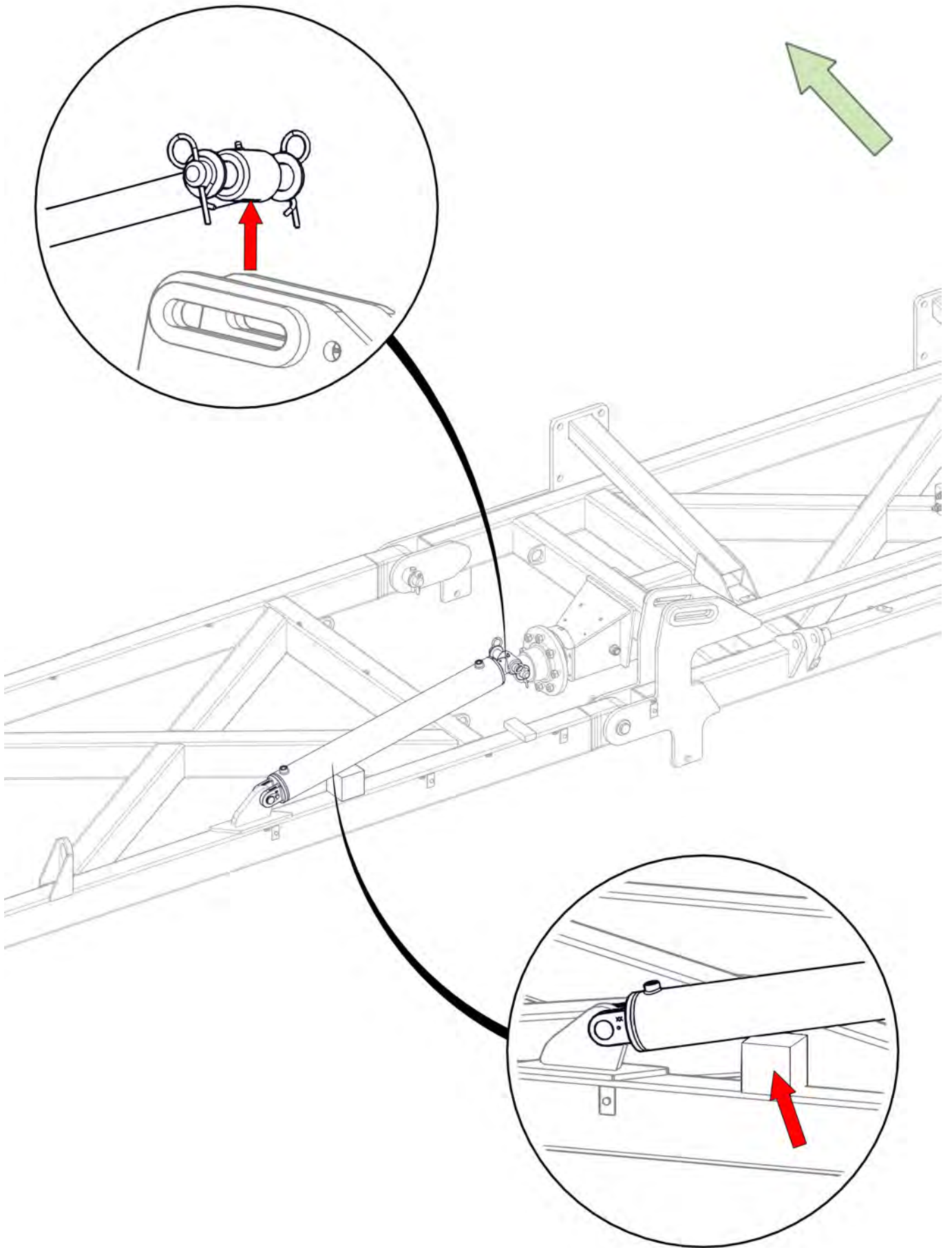

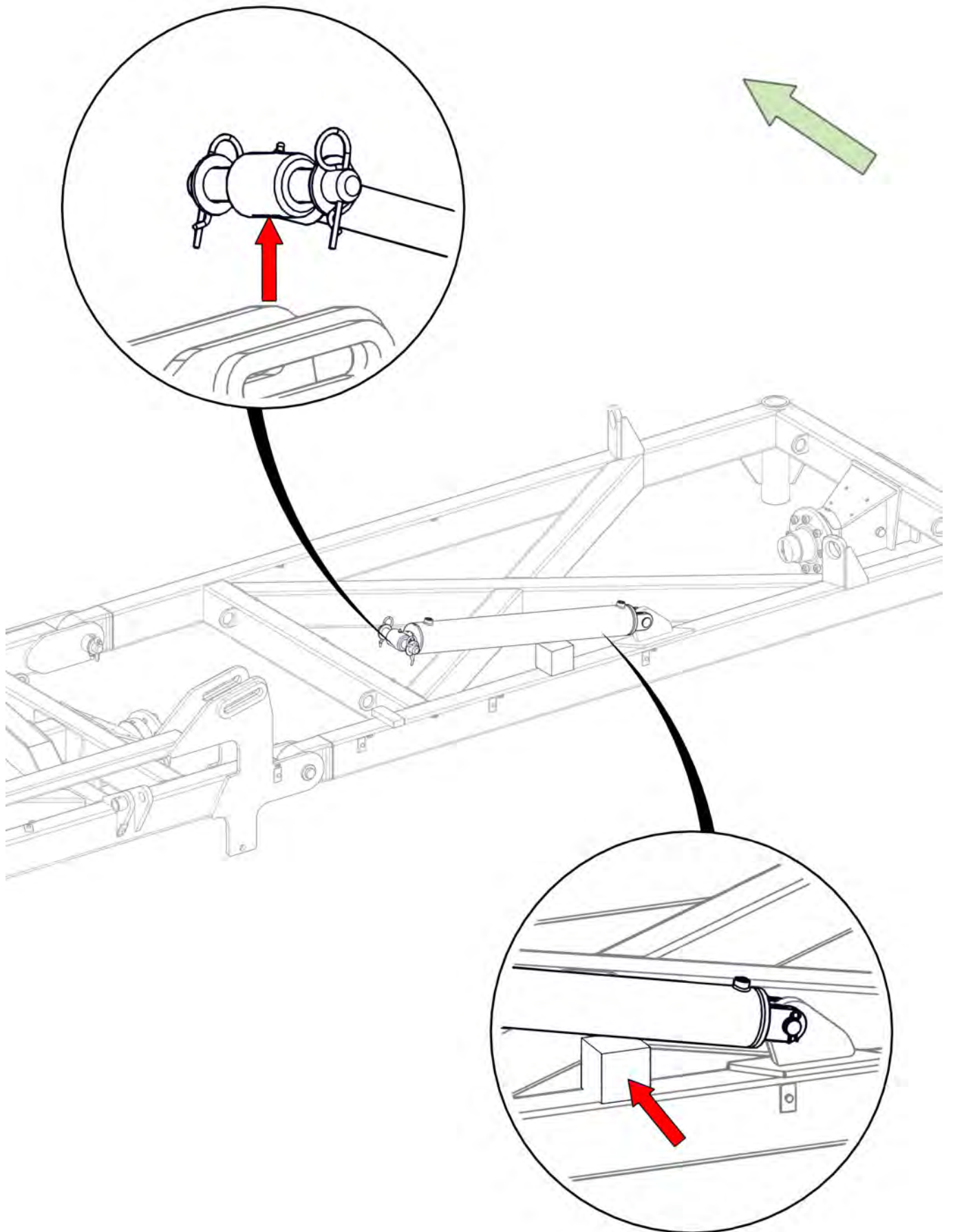

Item No.	Description	Number	Qty
1	3/4" JIC Male 3/4" UN O Ring Male 90° Elbow	0323-S91-1212	2

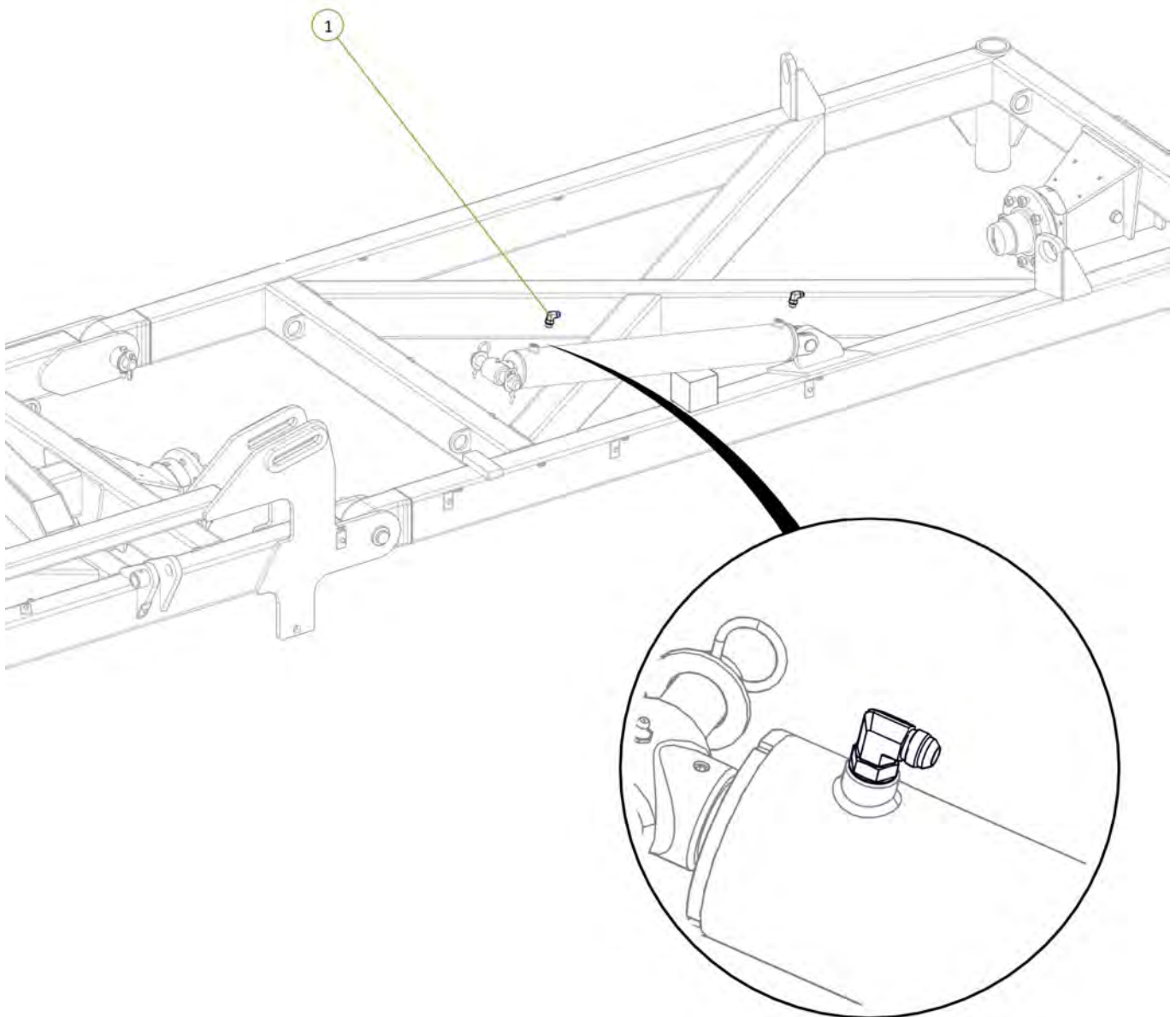

Item No.	Description	Number	Qty
1	1/2" BSPP Encapt Male 3/4" JIC Female Swive Adaptor	0323-S71-0812	1
2	Ball Valve BSPP 1/2"	0341-RL20SH-0808	1
3	1/2" BSPP Encapt Male 3/4" JIC Male Adaptor	0323-S74-0812	1

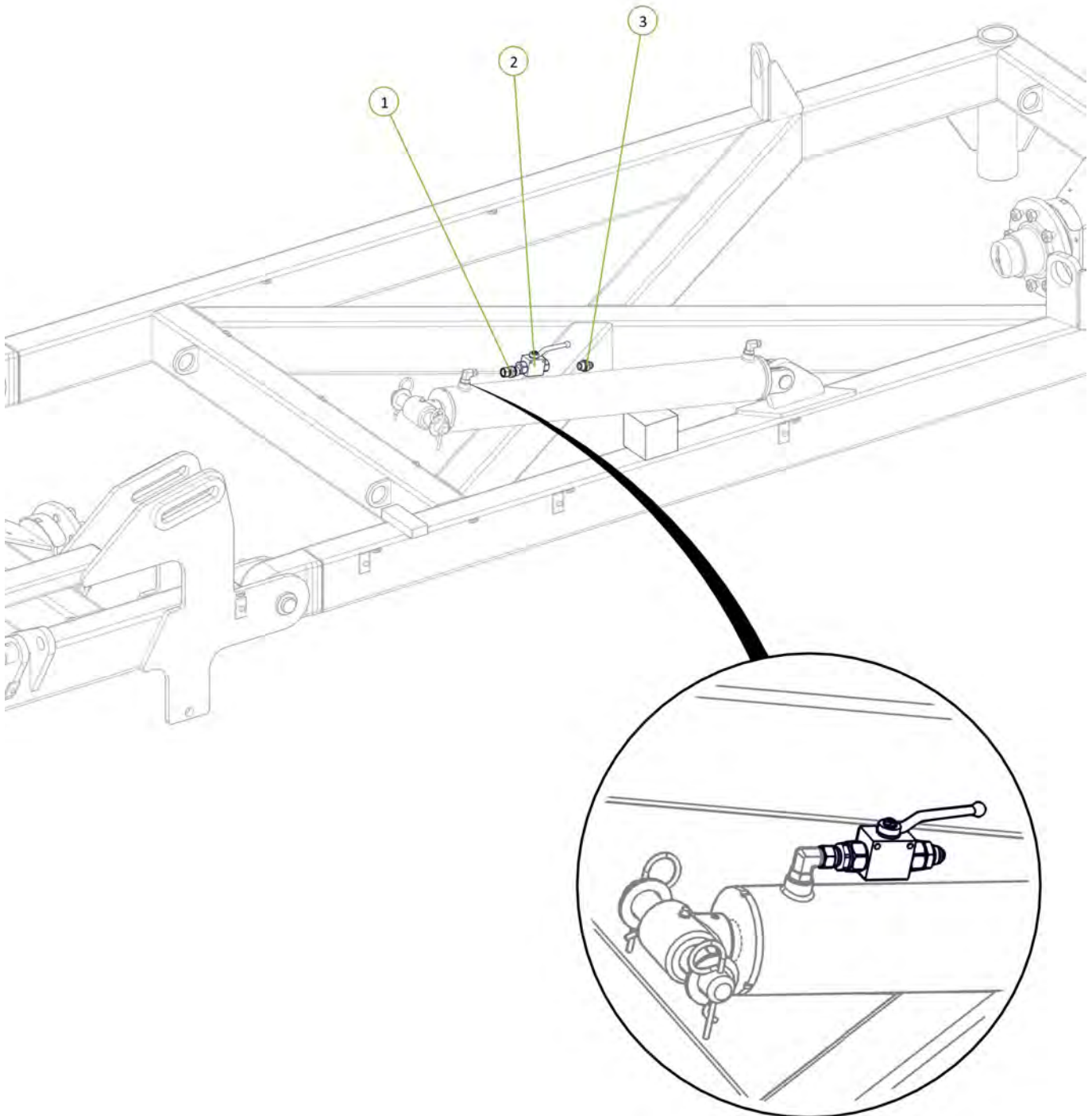

Item No.	Description	Number	Qty
1	Double Clamp Bolt Group 2	0325-RCD-2BH	1
2	Clamp top plate group 2	0325-RCD-2PT	1
3	17mm Clamp Jaws (Pair)	0325-RCD-17J	2
4	Double Clamp Stacking Plate (Non Ryco)	0325-SI-2-5D-W3	1
5	Double Clamp Stacking Bolt Group 2	0325-RCD-2BS	1

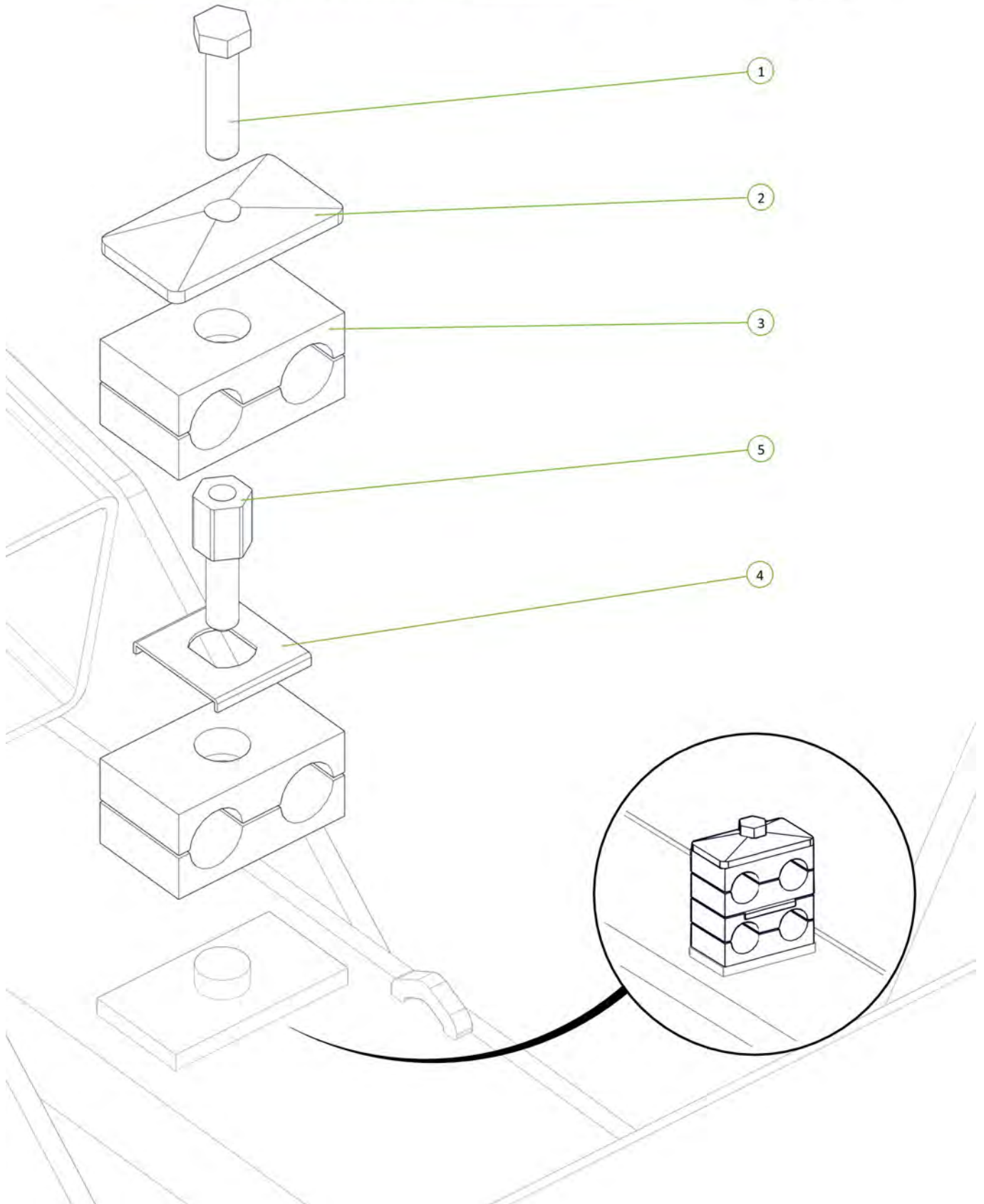

Item No.	Description	Number	Qty
1	Valve RE Port to RH Wing Cylinder Rear Port	PH30S-20	1
2	Valve RR Port to RH Wing Cylinder Rod Port	PH30S-22	1

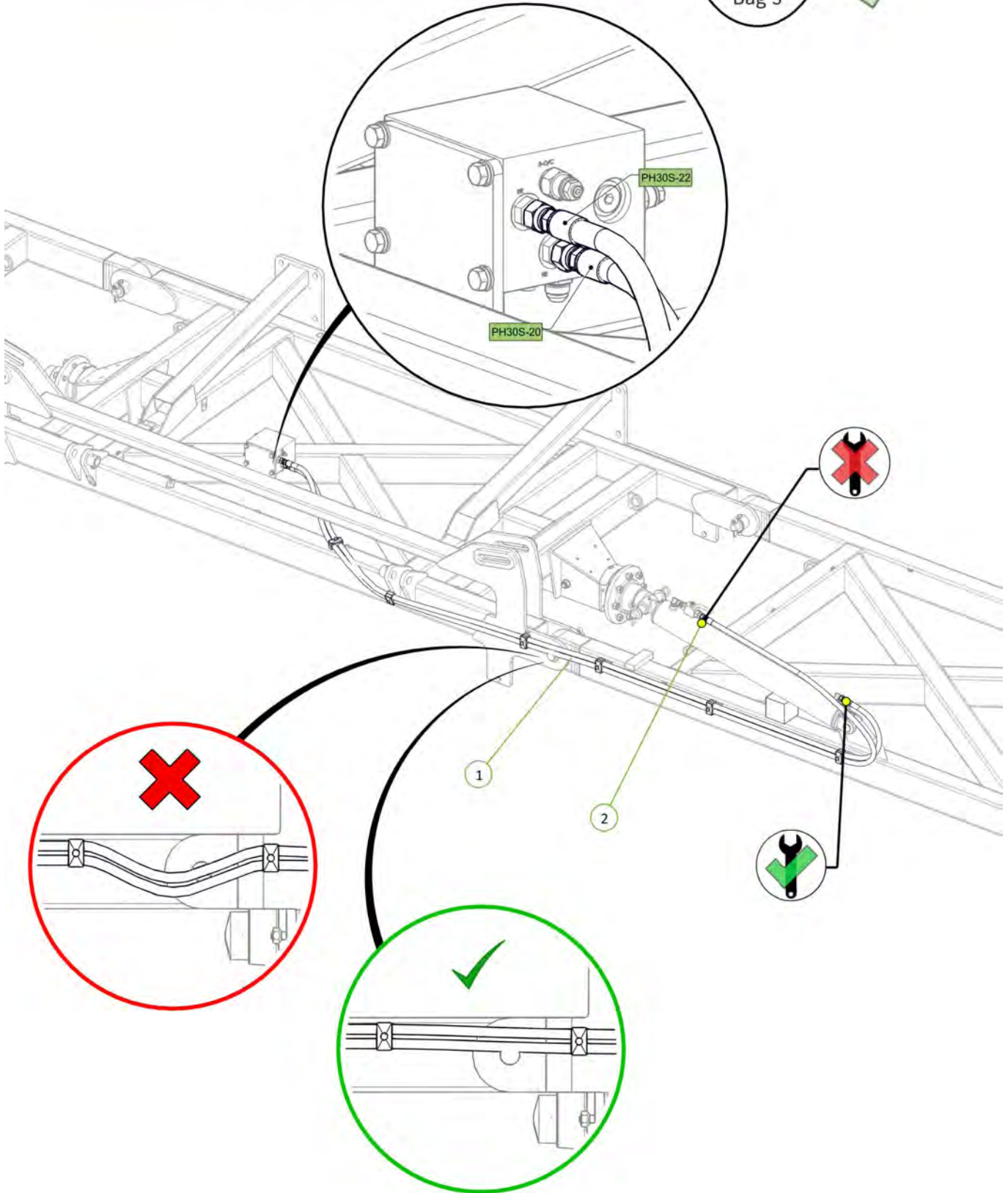

Item No.	Description	Number	Qty
1	3/4" JIC Male 3/4" UN O Ring Male 90° Elbow	0323-S91-1212	2

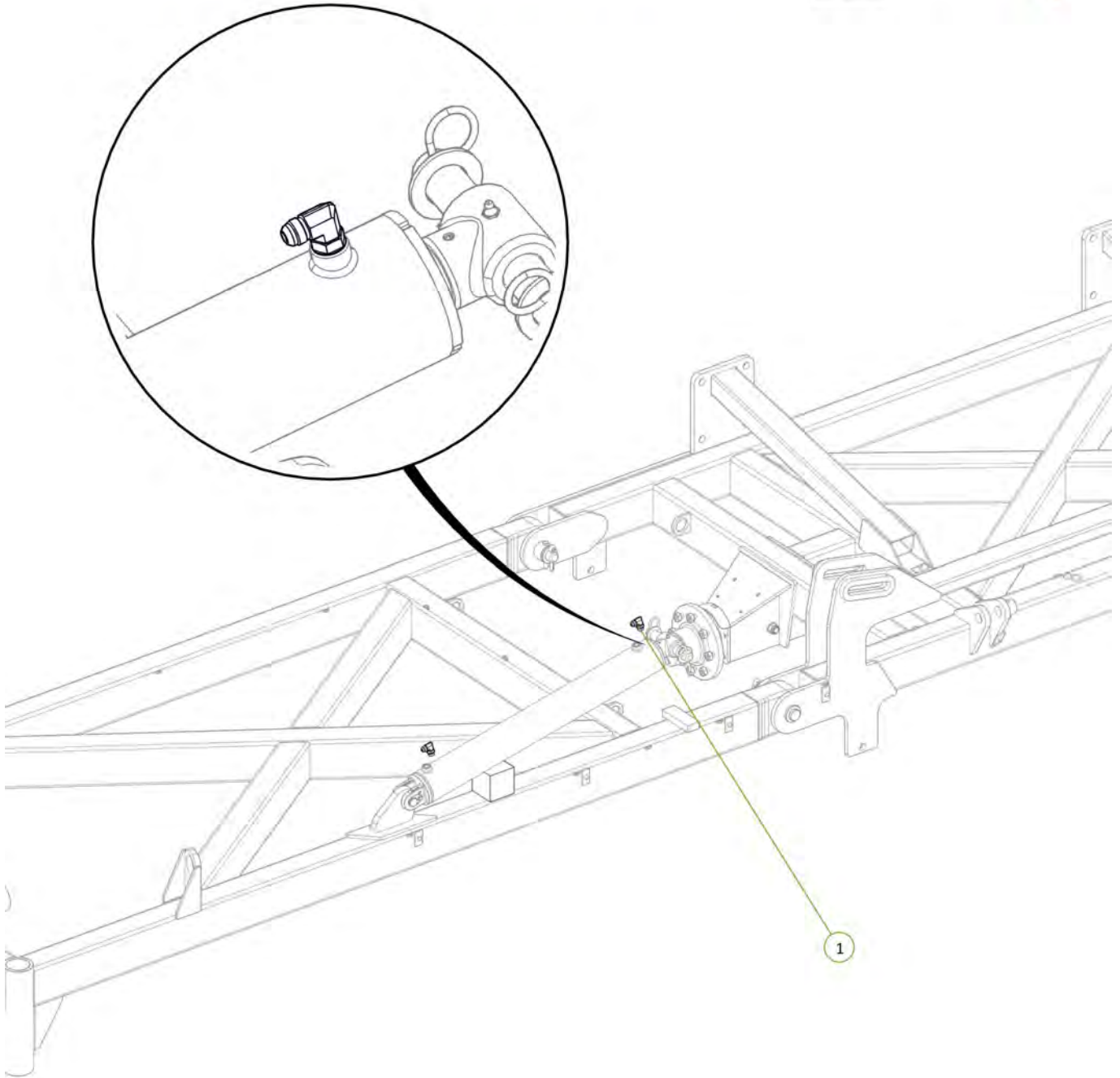

Item No.	Description	Number	Qty
1	1/2" BSPP Encapt Male 3/4" JIC Female Swive Adaptor	0323-S71-0812	1
2	Ball Valve BSPP 1/2"	0341-RL20SH-0808	1
3	1/2" BSPP Encapt Male 3/4" JIC Male Adaptor	0323-S74-0812	1

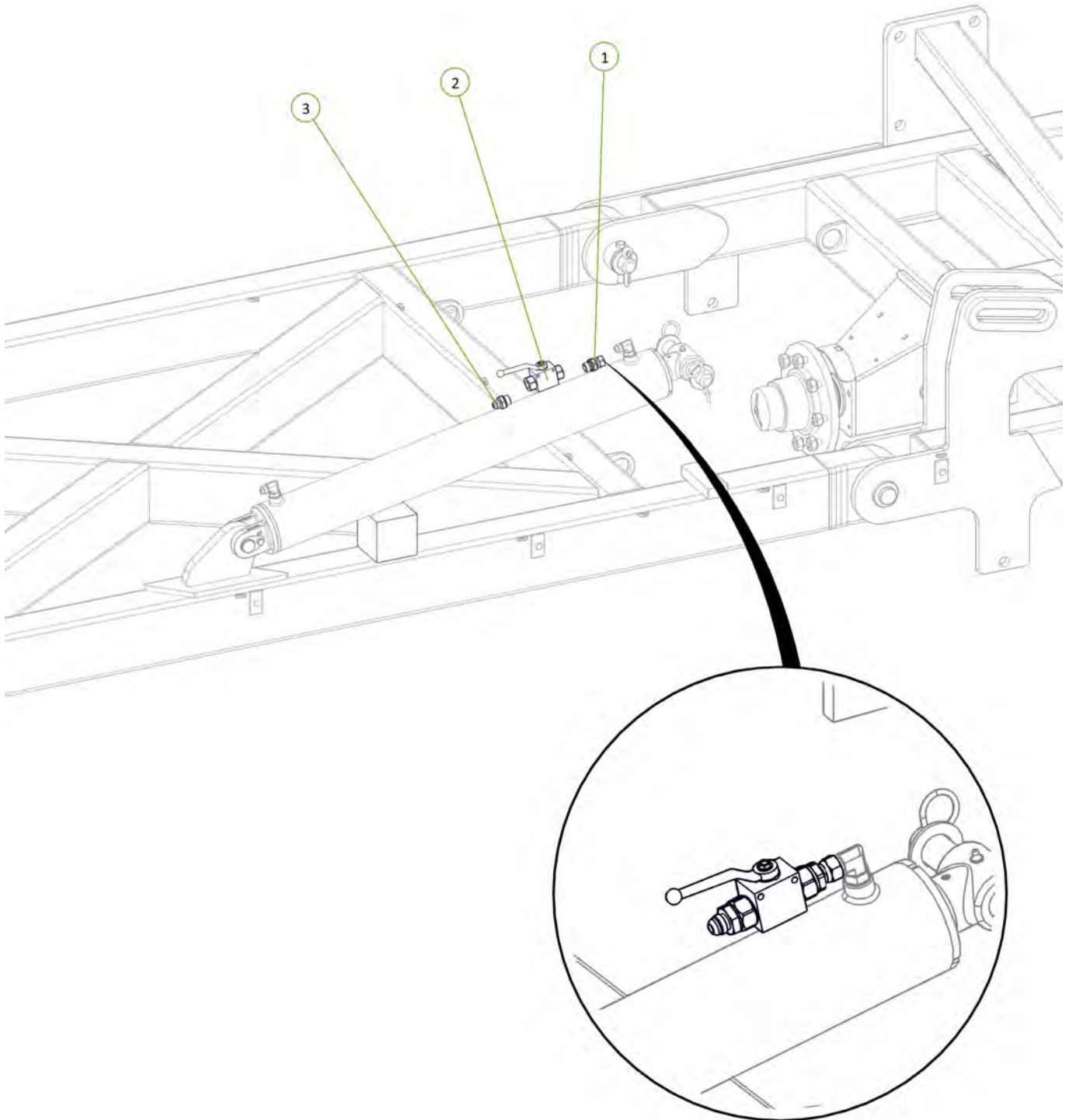

Item No.	Description	Number	Qty
1	Valve LE Port to LH Wing Cylinder Rear Port	PH30S-19	1
2	Valve LR Port to LH Wing Cylinder Rod Port	PH30S-21	1

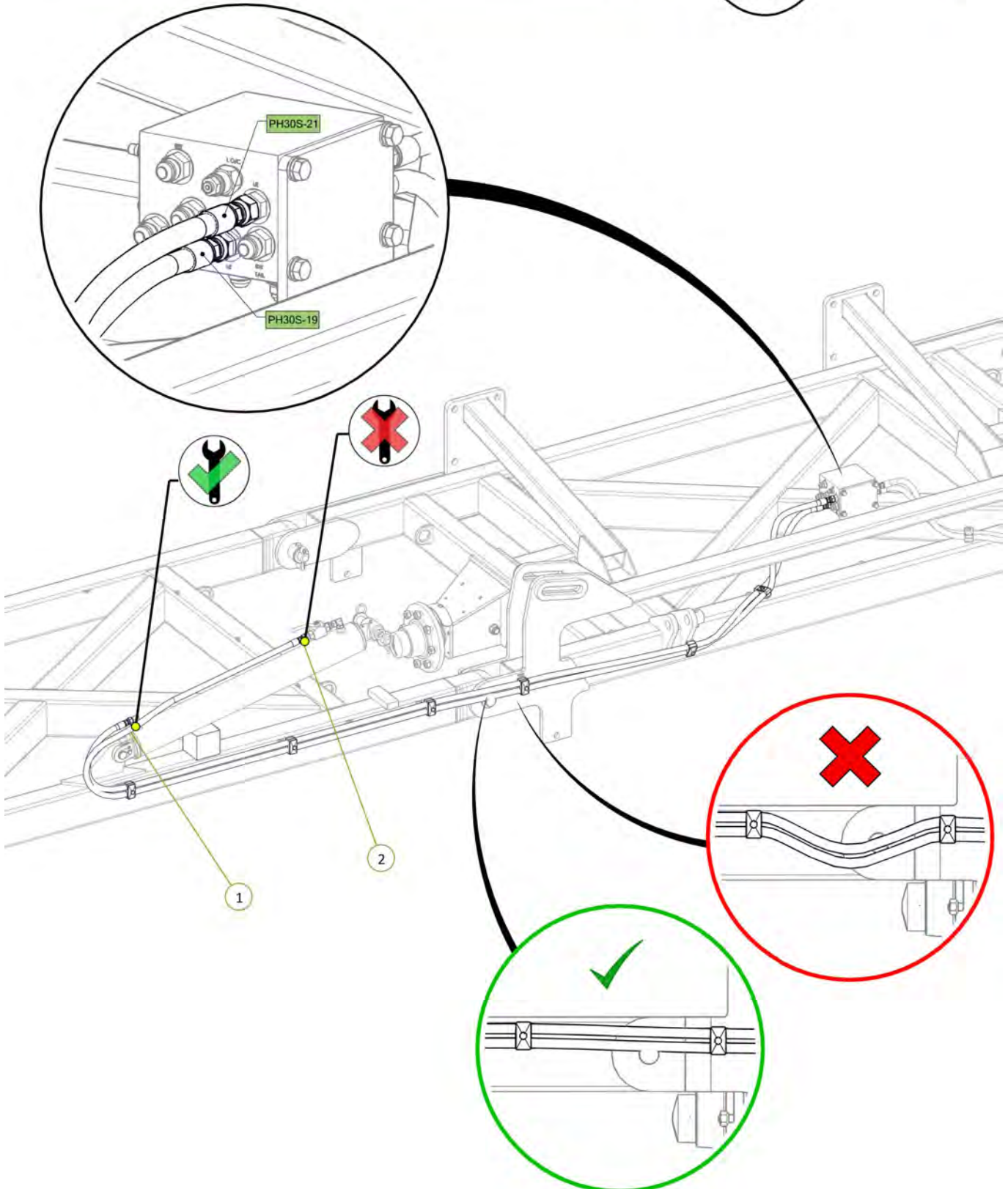

Item No.	Description	Number	Qty
1	1/2" BSPP Encapt Male 3/4" JIC Female Swive Adaptor	0323-S71-0812	2
2	In Line Hydraulic Oil Filter	0343-924001261	2
3	1/2" BSPP Encapt Male 3/4" JIC Male Adaptor	0323-S74-0812	2

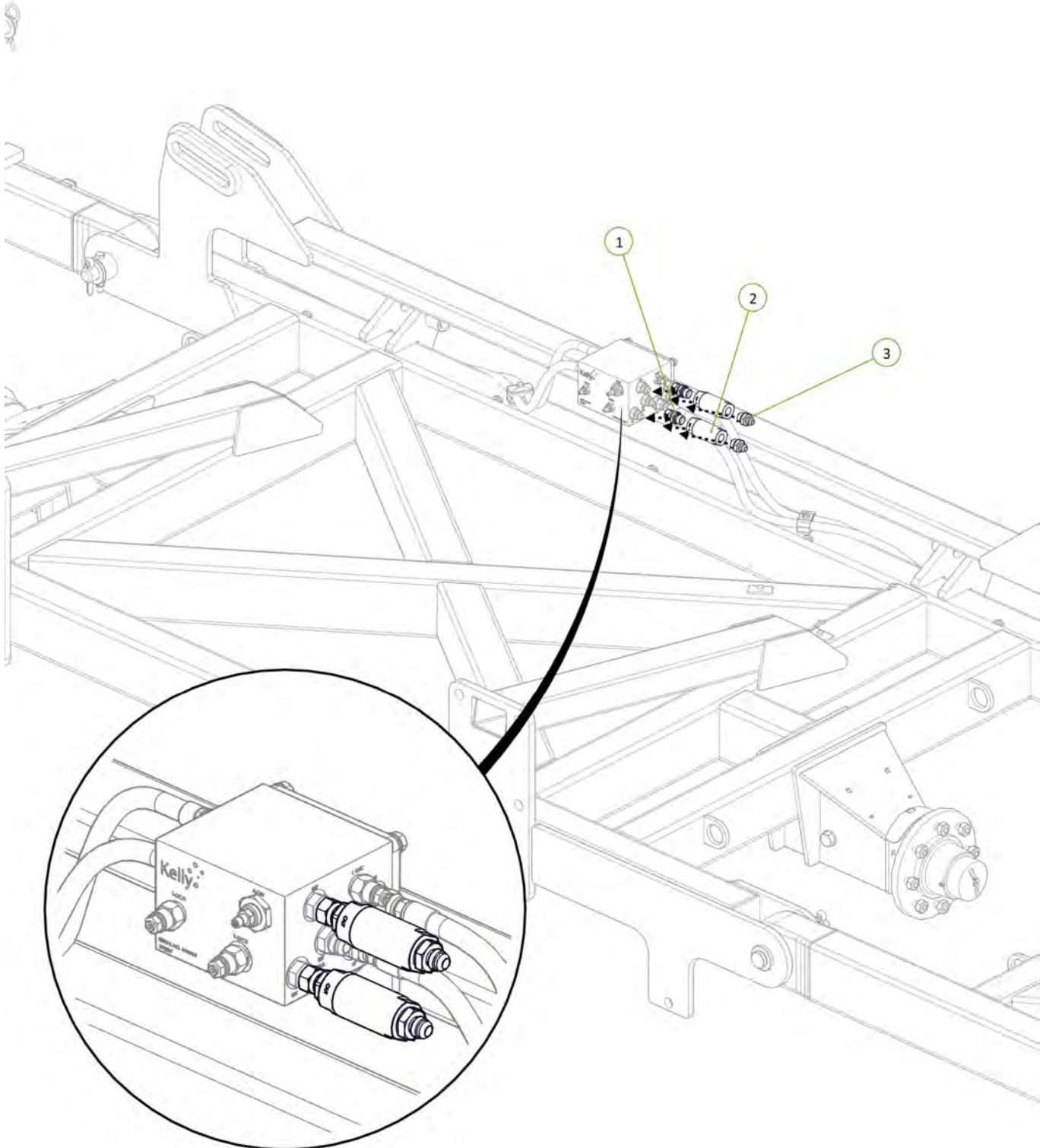

Item No.	Description	Number	Qty
1	Tractor to Sequence Valve EXT Port fitted with Green Extend Decal	PH30S-01-GE-EXT	1
2	Tractor to Sequence Valve RCT Port fitted with Green Retract Decal	PH30S-01-GR-RCT	1

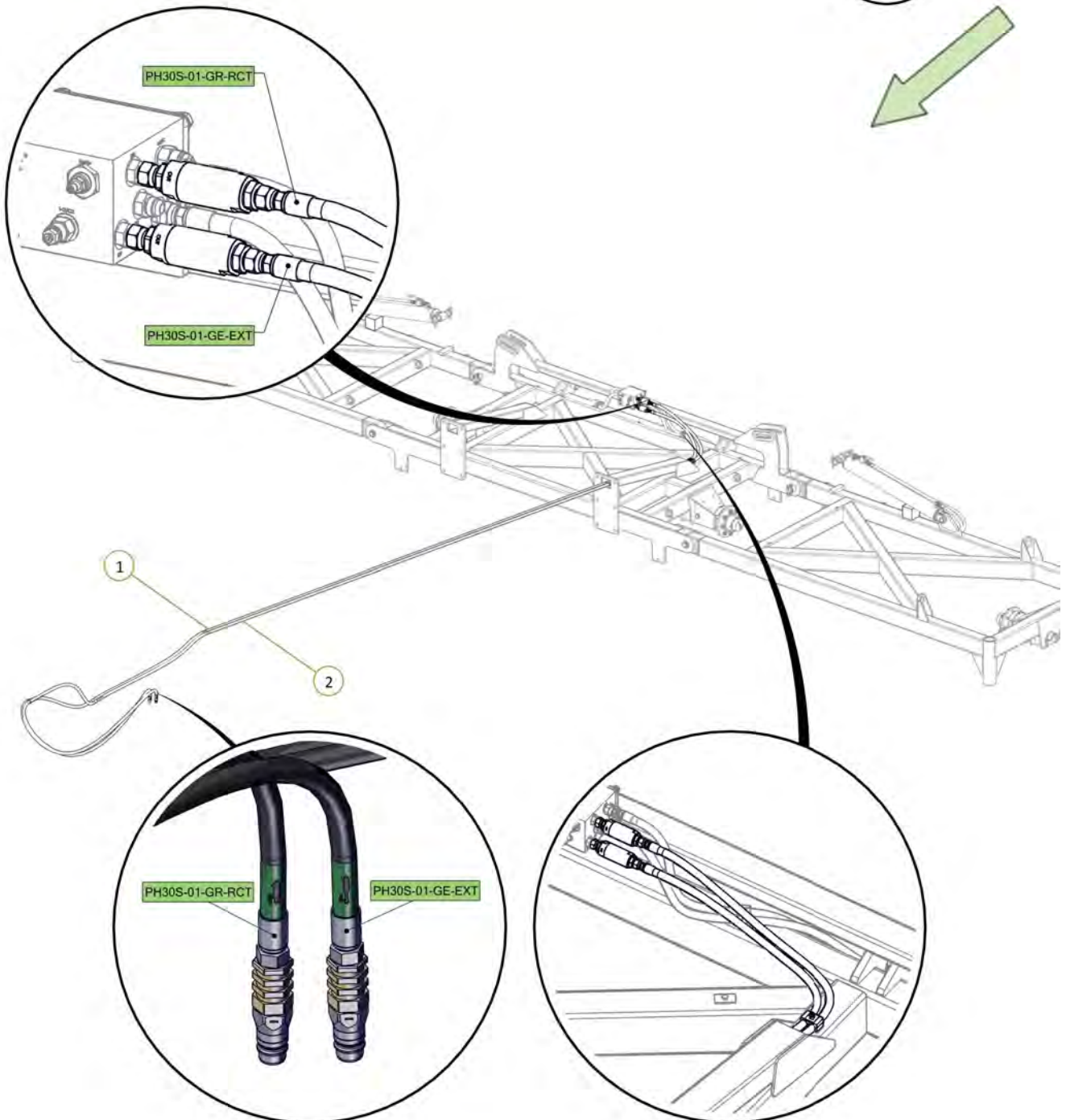
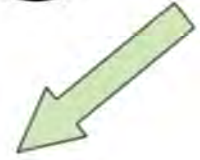

Ensure retract hose fittings are loose to allow air to escape

Check cylinders are chocked up to prevent clashing during extension

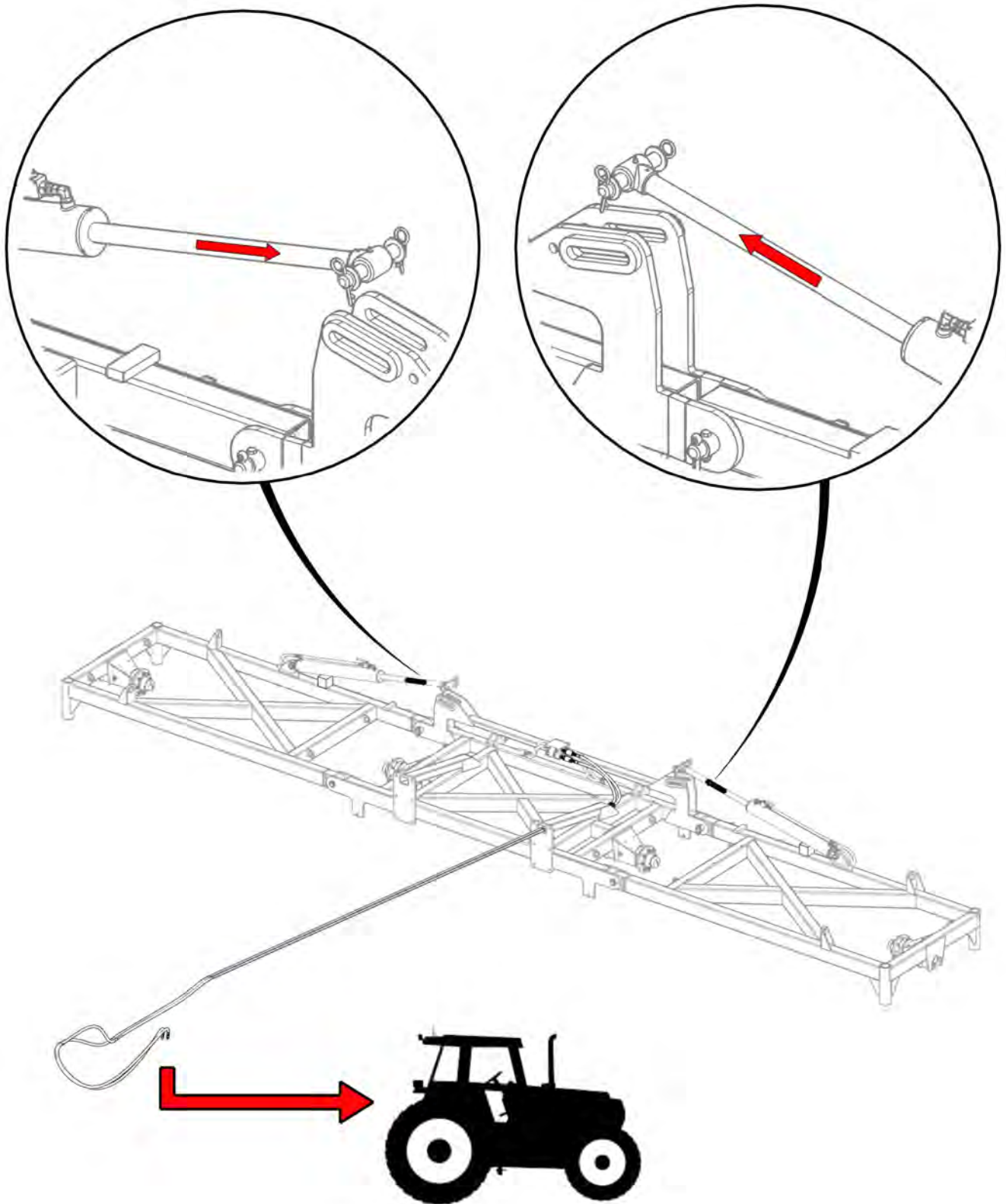

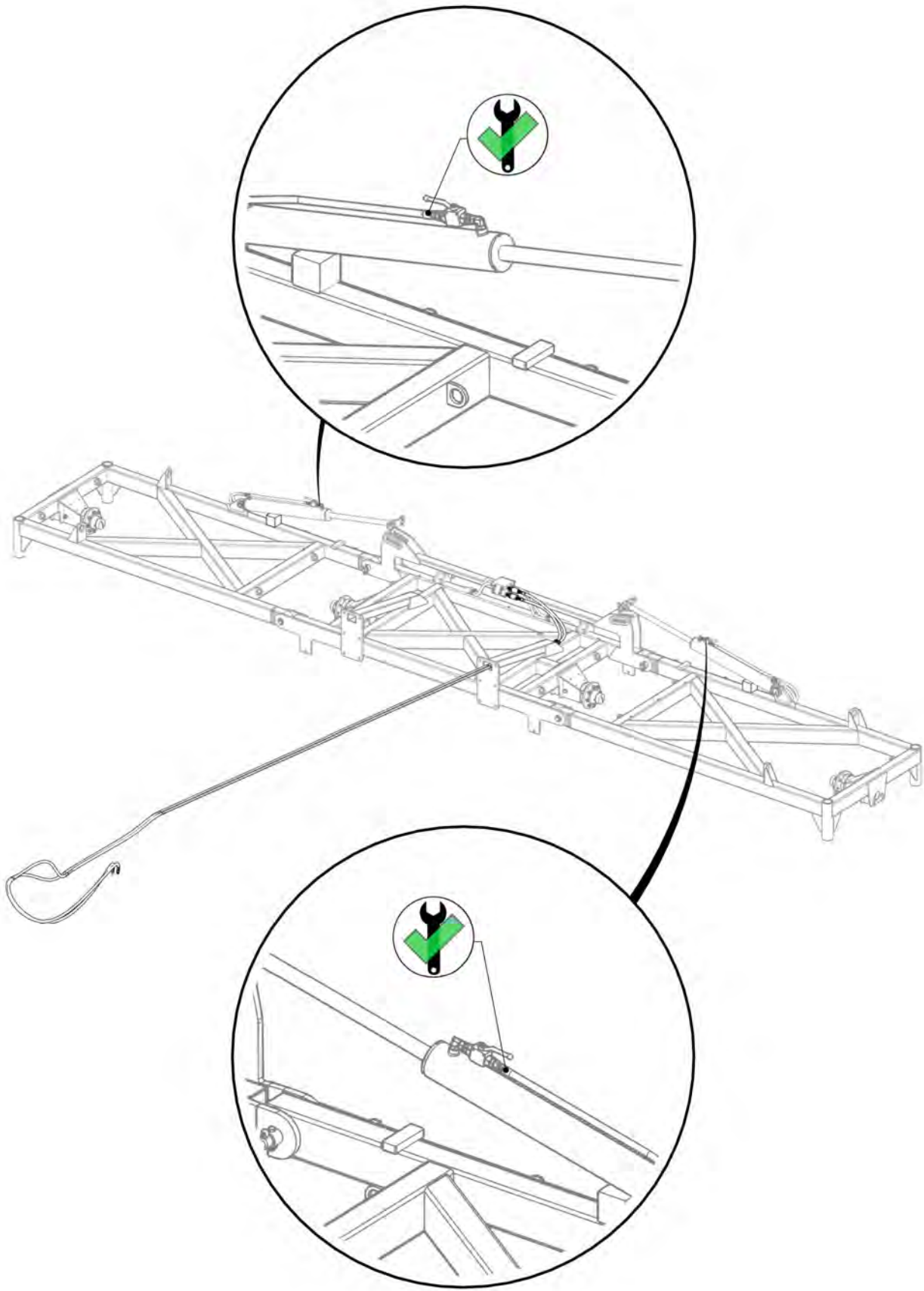

Tighten retract fittings

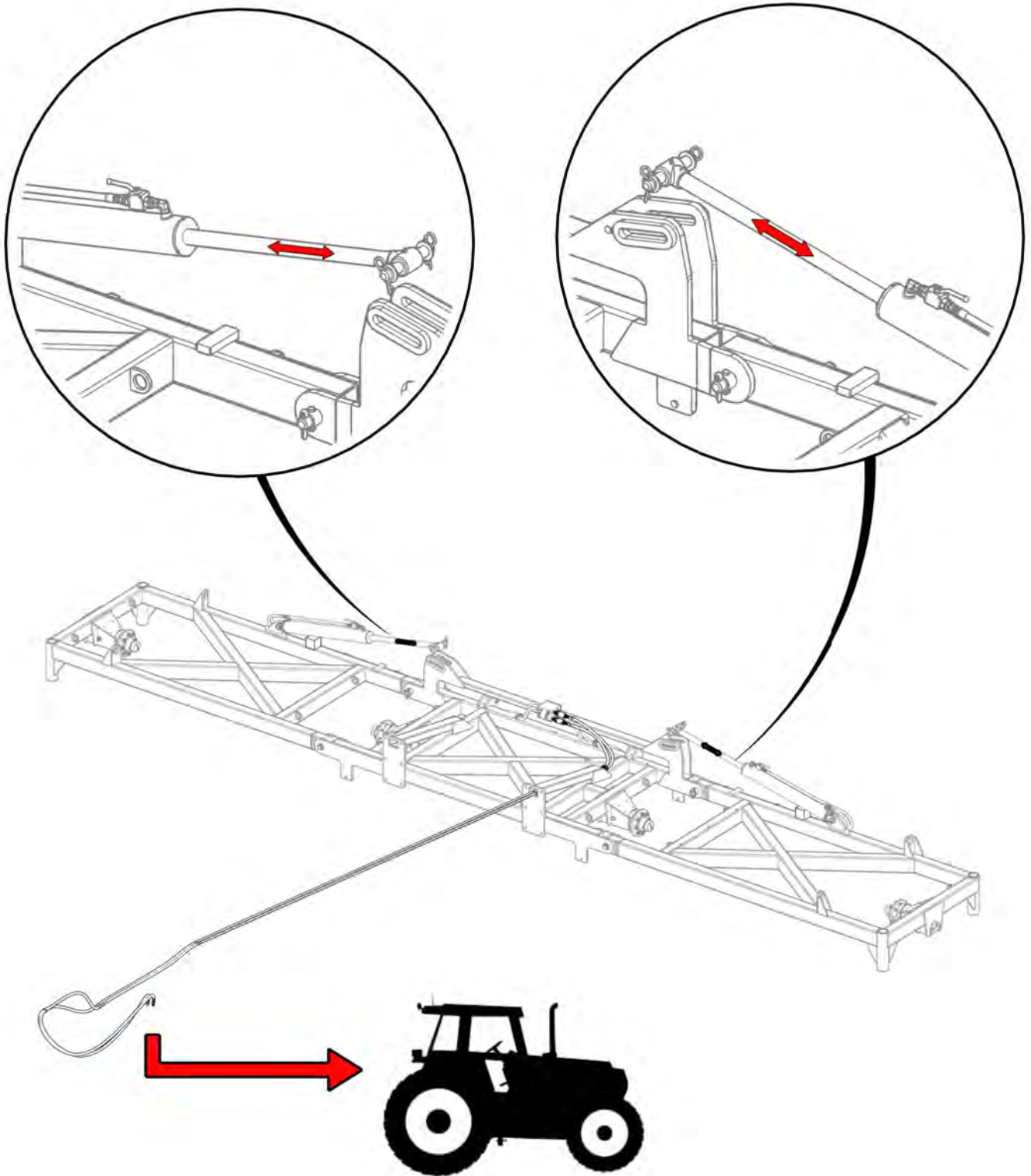

Cycle cylinders to expel air from system

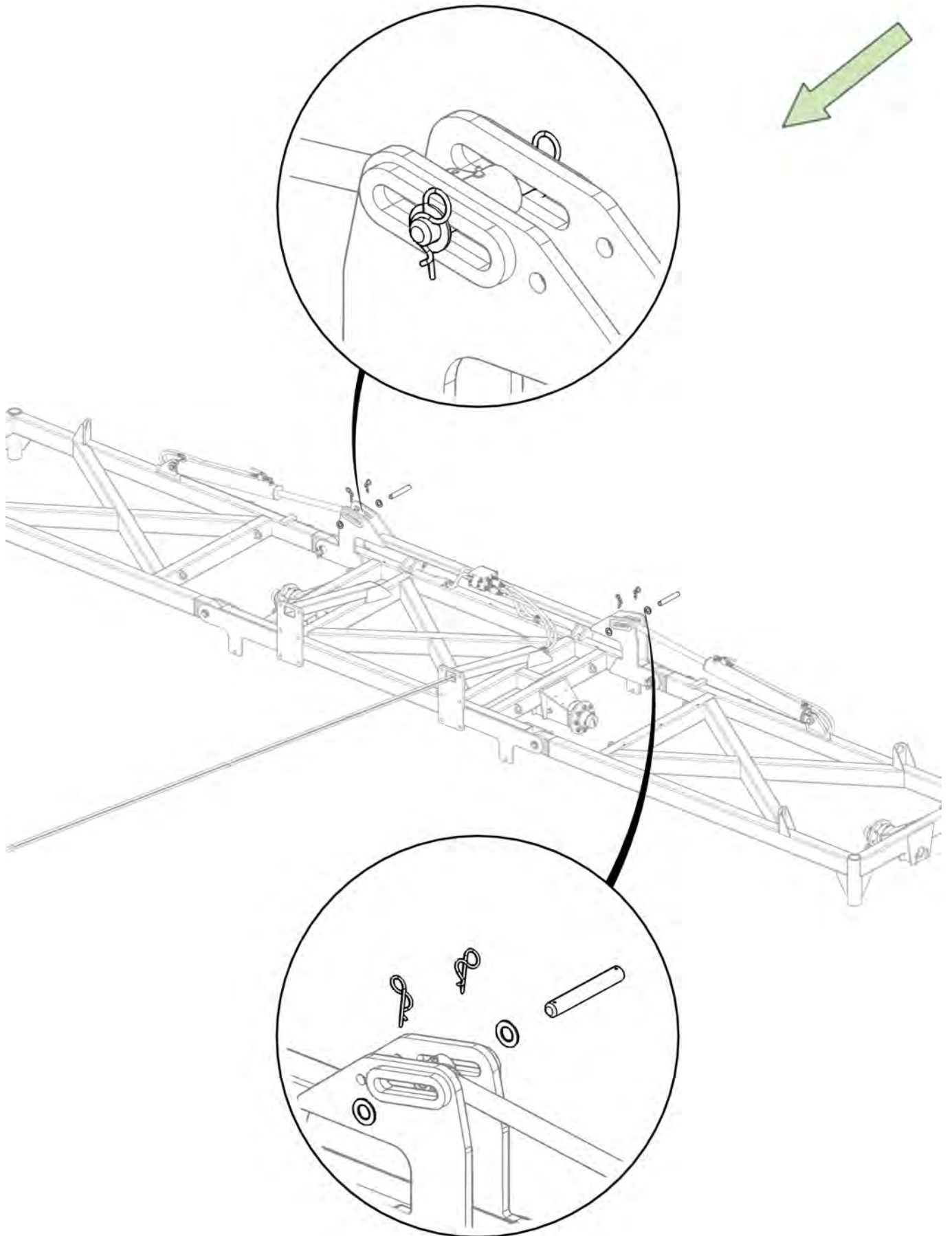

Item No.	Description	Number	Qty
1	30' Main Pull	0830-02-2	1
2	Nyloc Nut M24	0221-NYL24	12
3	M24 x 80 grade 8.8 zp Bolt	0211-2480	12
4	Washer Flat M24	0231-F24	24

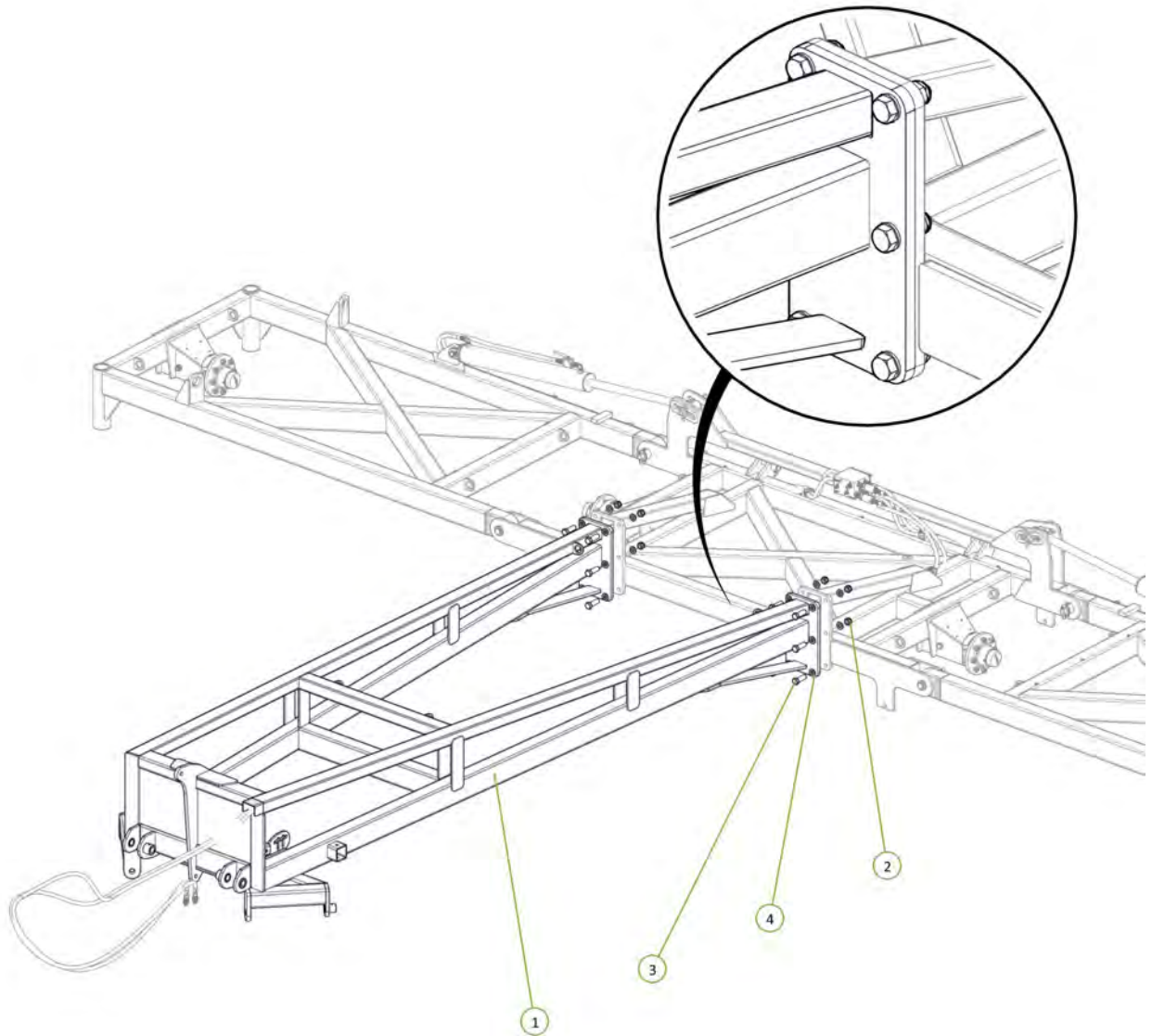

Item No.	Description	Number	Qty
1	400/55-22.5 Tyre on 8 on 8" PCD Rim (Left Hand)	0751-400-55-22.5TR-L	2
2	400/55-22.5 Tyre on 8 on 8" PCD Rim (Right Hand)	0751-400-55-22.5TR-R	2

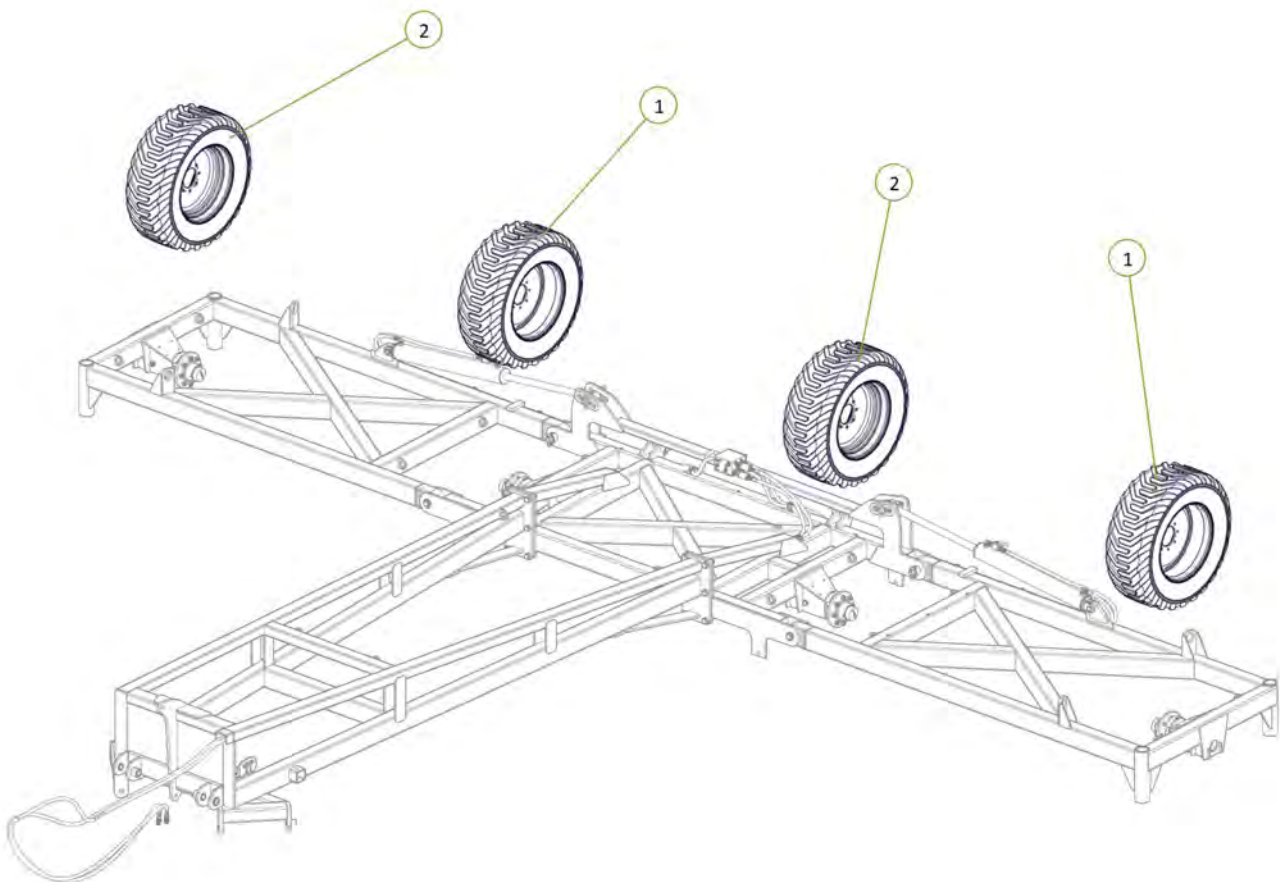

Tighten wheel nuts to 100ft-lb / 140Nm

Item No.	Description	Number	Qty
1	Tapered T-Bar Drawbar	1510-08-2	1
2	Drawbar Pivot Bush	0801-B423838	4
3	Walking Axle Linkage Pivot Pin	1601-P38-220	2
4	Cotter Pin M13 x 63	0261-PINC1363	2
5	Nyloc Nut M12	0221-NYL12	2
6	M12 x 90 Class 8.8 ZP Bolt	0211-1290	2

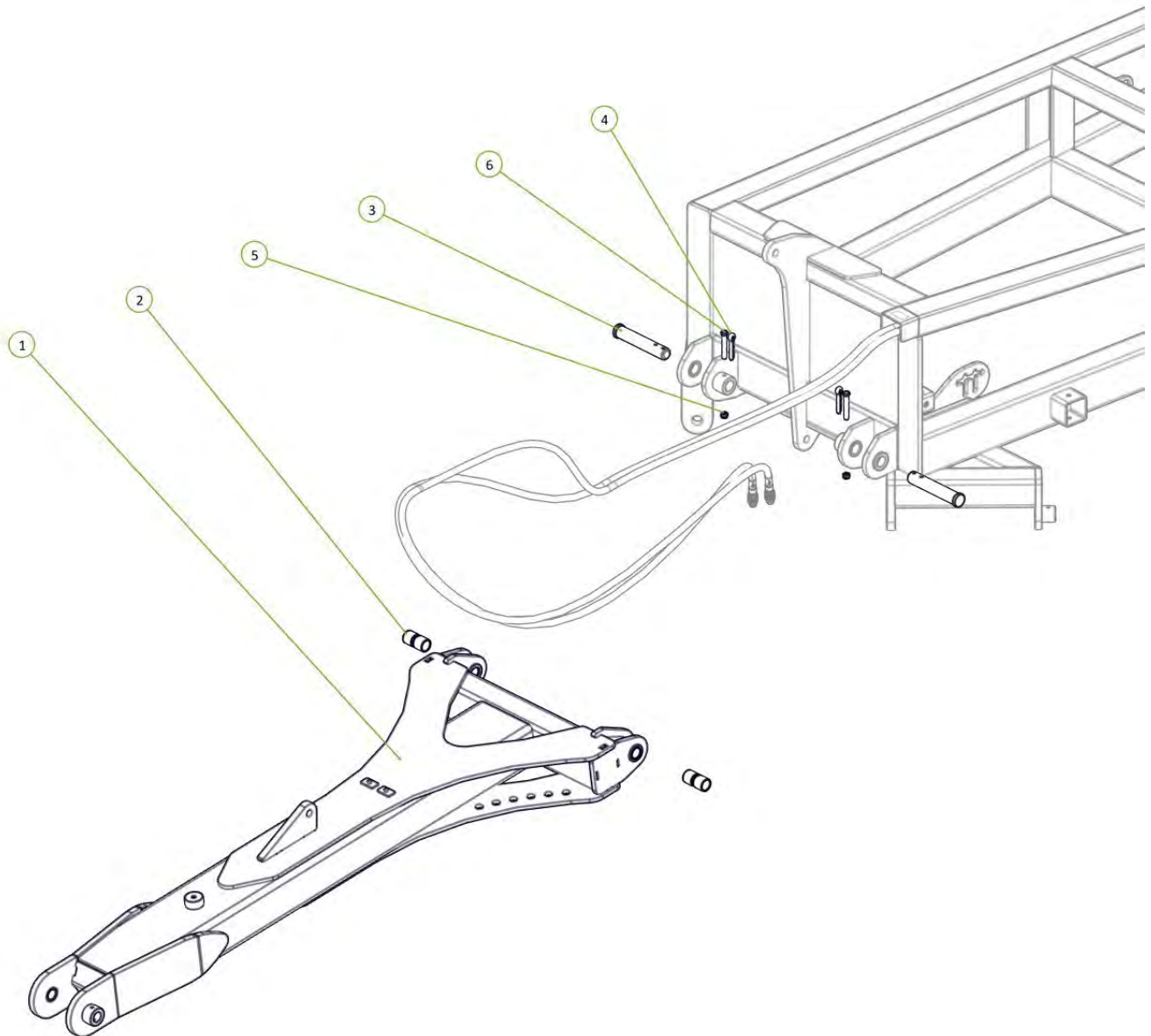

Item No.	Description	Number	Qty
1	Tow Hitch	0810-09	1
2	35 ID x 50mm DX Bush	0113-MB3550DX	2
3	Grease Nipple 1/4" UNF 45°	0181-GN1/445	2
4	Tow Hitch Pivot Pin	0801-10-14	1
5	M12 x 90 Class 8.8 ZP Bolt	0211-1290	2
6	Nyloc Nut M12	0221-NYL12	2

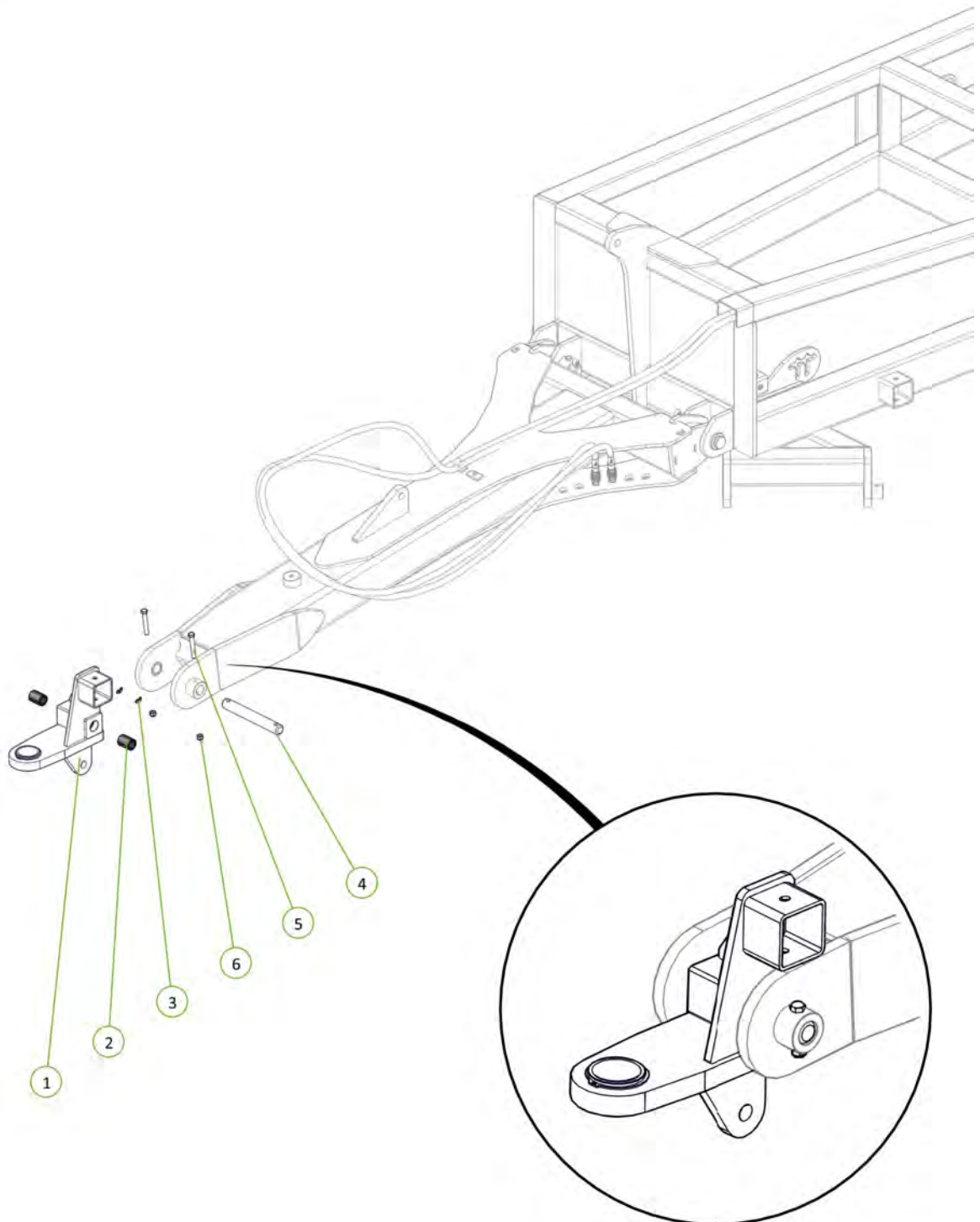

Item No.	Description	Number	Qty
1	Parallel Arm	0810-58	1
2	Clevis Pin 25mm x 75mm	0801-KE0307-1	2
3	Washer Flat M24	0231-F24	2
4	Cotter Pin M5 x 50	0261-PINC550	2

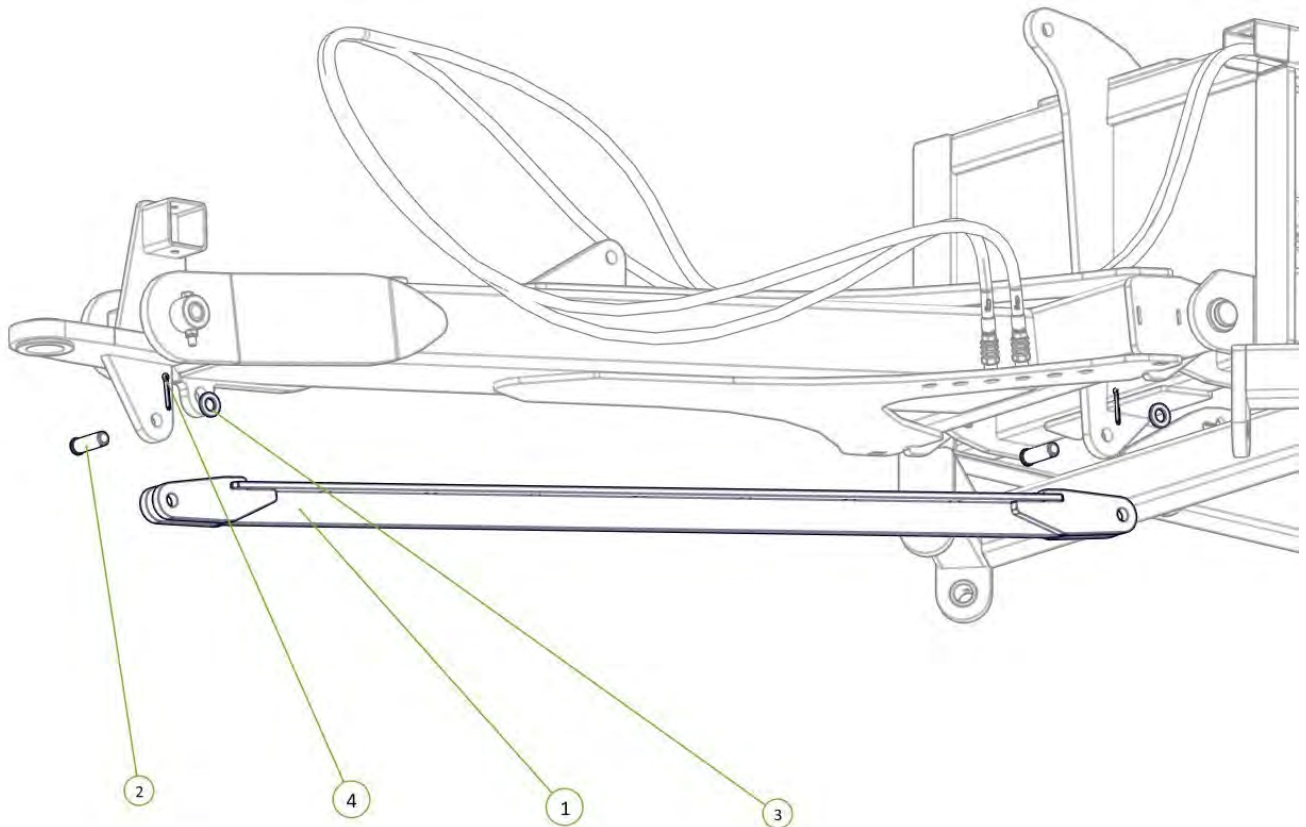

Item No.	Description	Number	Qty
1	3" Bore x 12" Stroke 1.5" Rod Extended Hydraulic Cylinder	0311-312EXT	1

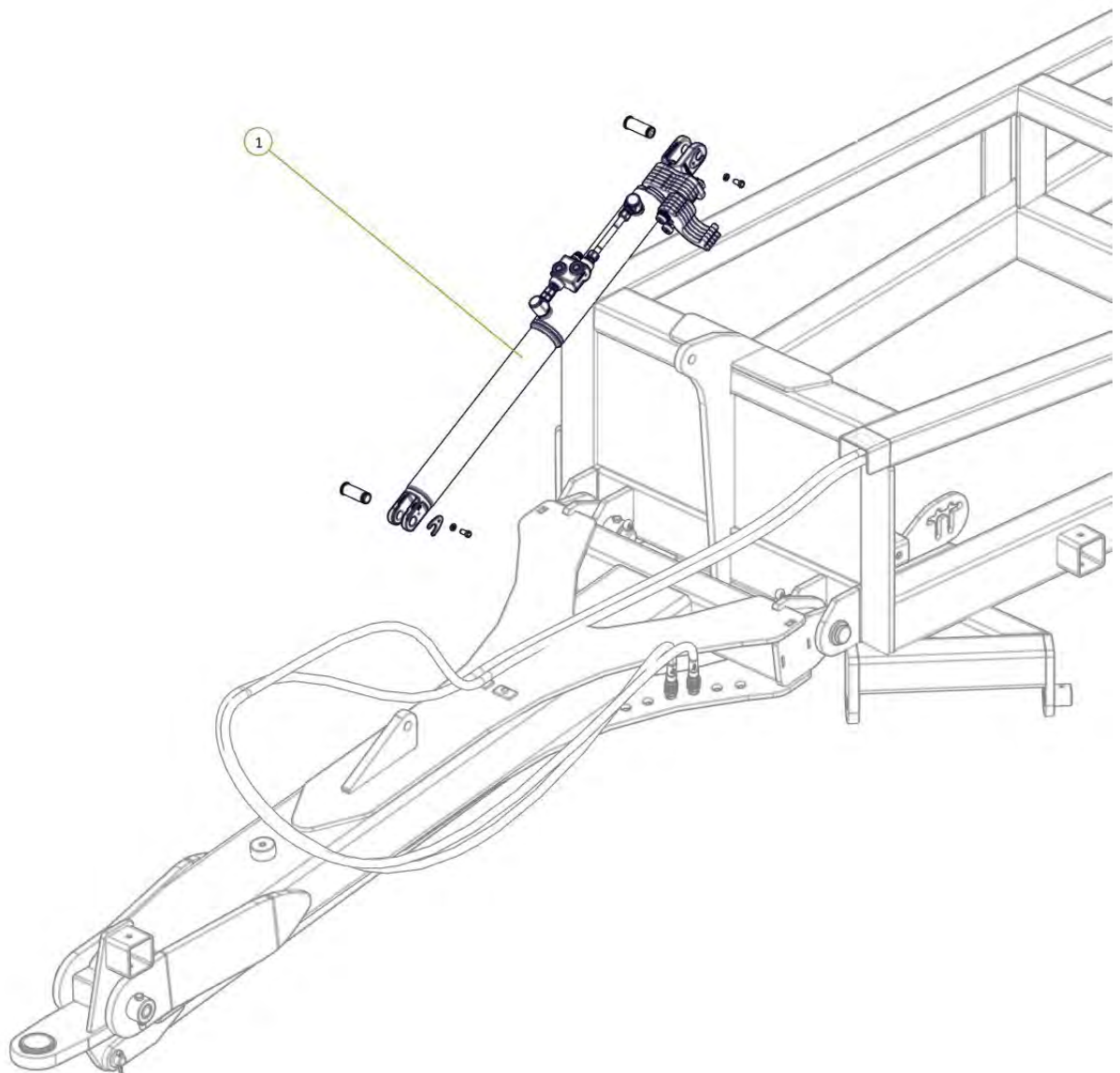

Item No.	Description	Number	Qty
1	Heavy Duty Jack	0801-SAK45B	1
2	Jack Pin	0801-B3077	1

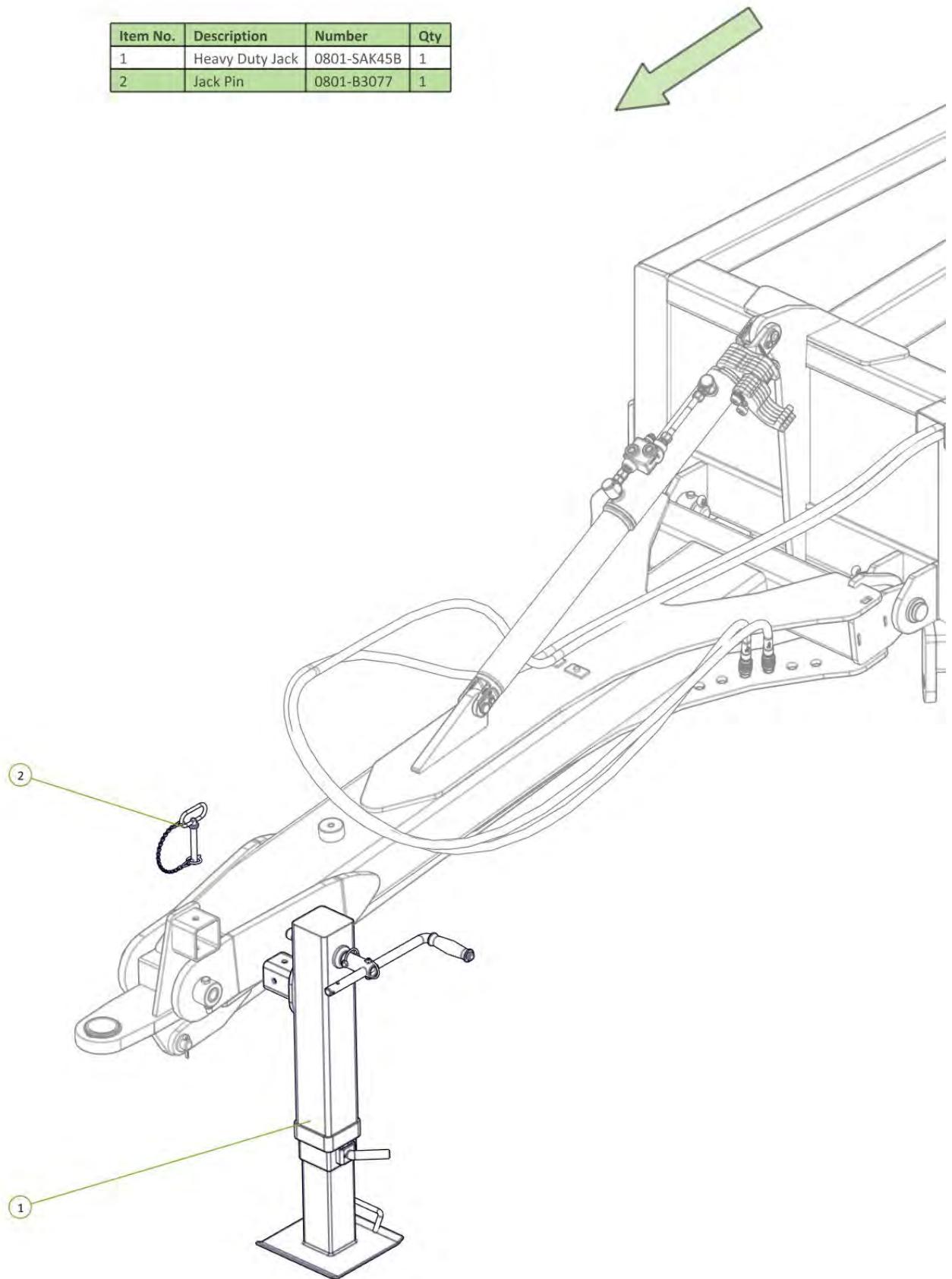

Item No.	Description	Number	Qty
1	Hose Post Spring	1601-CDB-00-0012	1
2	Washer Flat M16	0231-F16	1
3	Washer Spring M16	0231-S16	1
4	M16 x 35 grade 8.8 zp Bolt	0211-1635	1

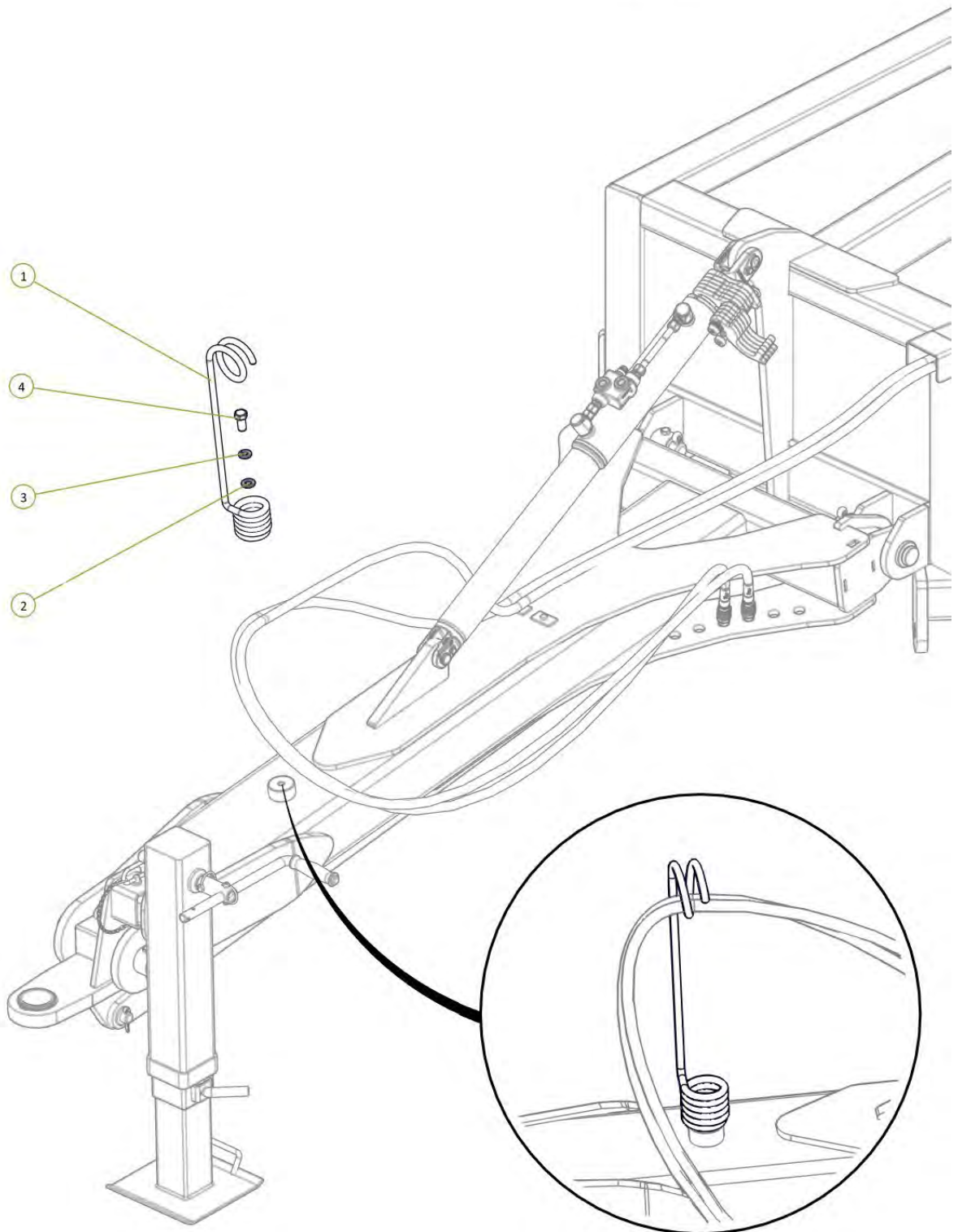

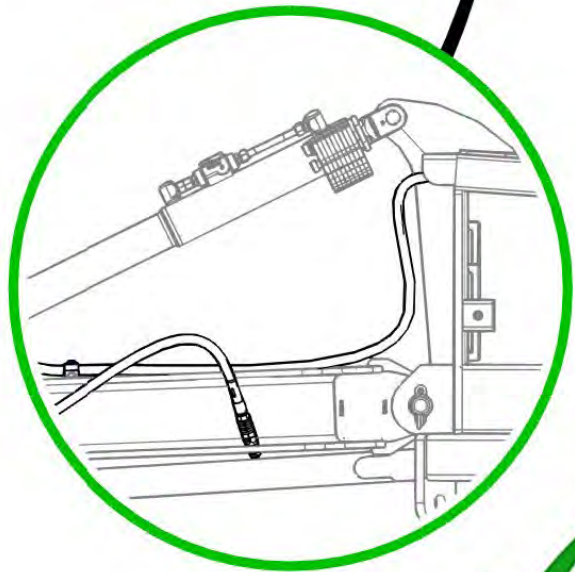
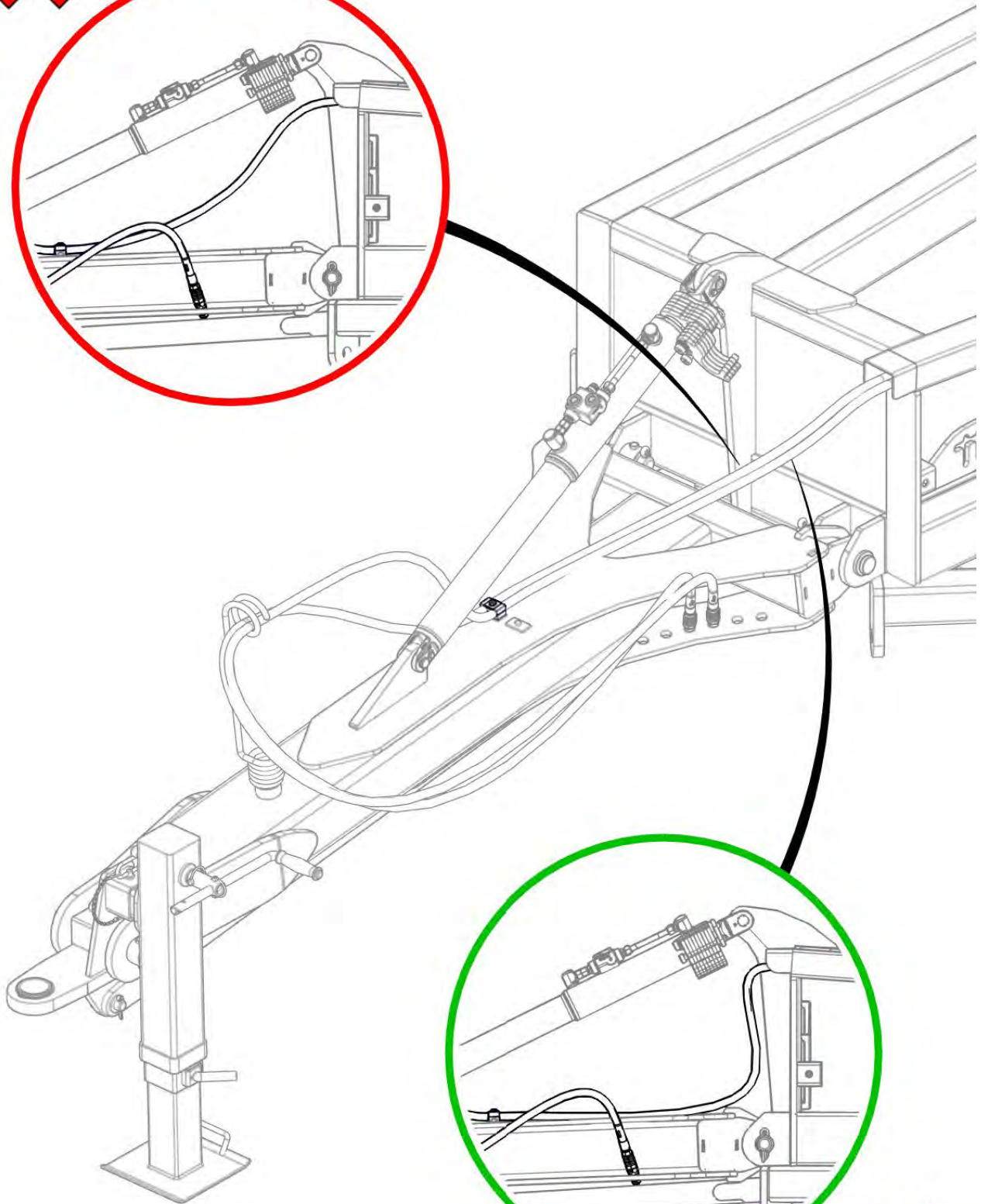
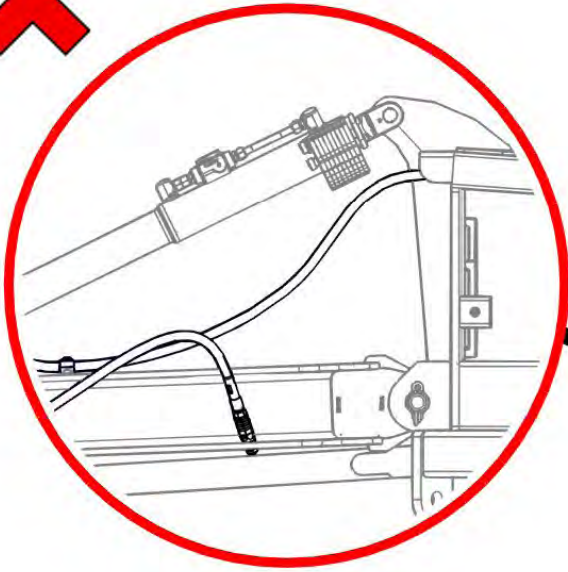

Item No.	Description	Number	Qty
1	1/2" BSPP Encapt Male 3/4" JIC Female Swive Adaptor	0323-S71-0812	2
2	In Line Hydraulic Oil Filter	0343-924001261	2
3	1/2" BSPP Encapt Male 3/4" JIC Male Adaptor	0323-S74-0812	2

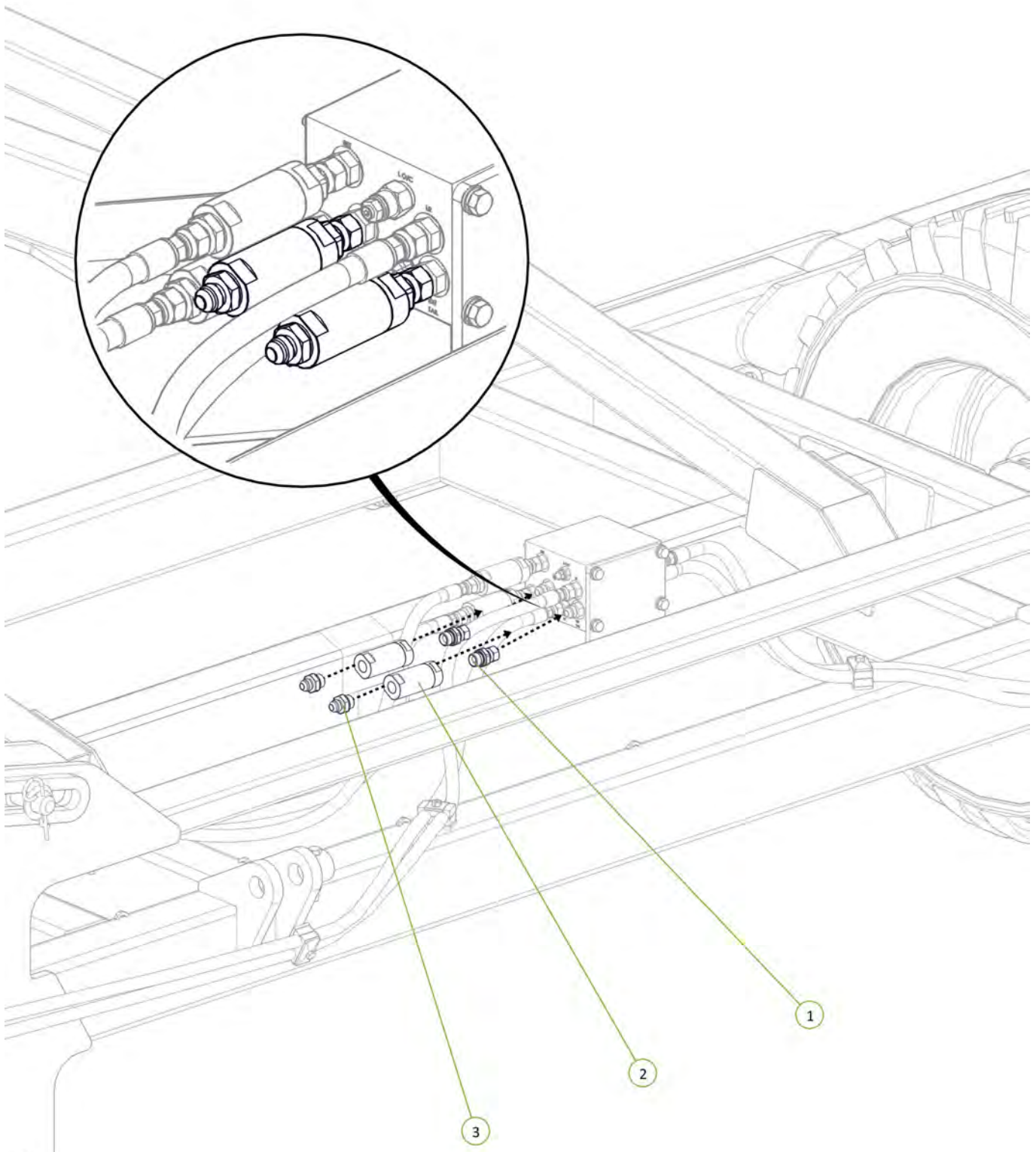
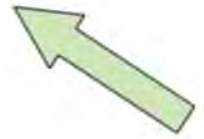

Item No.	Description	Number	Qty
1	Tractor to Sequence Valve TAIL EXT Port fitted with Yellow Extend Decal	PH30S-01-YE-TAIL EXT	1
2	Tractor to Sequence Valve TAIL RET Port fitted with Yellow Retract Decal	PH30S-01-YR-TAIL RCT	1

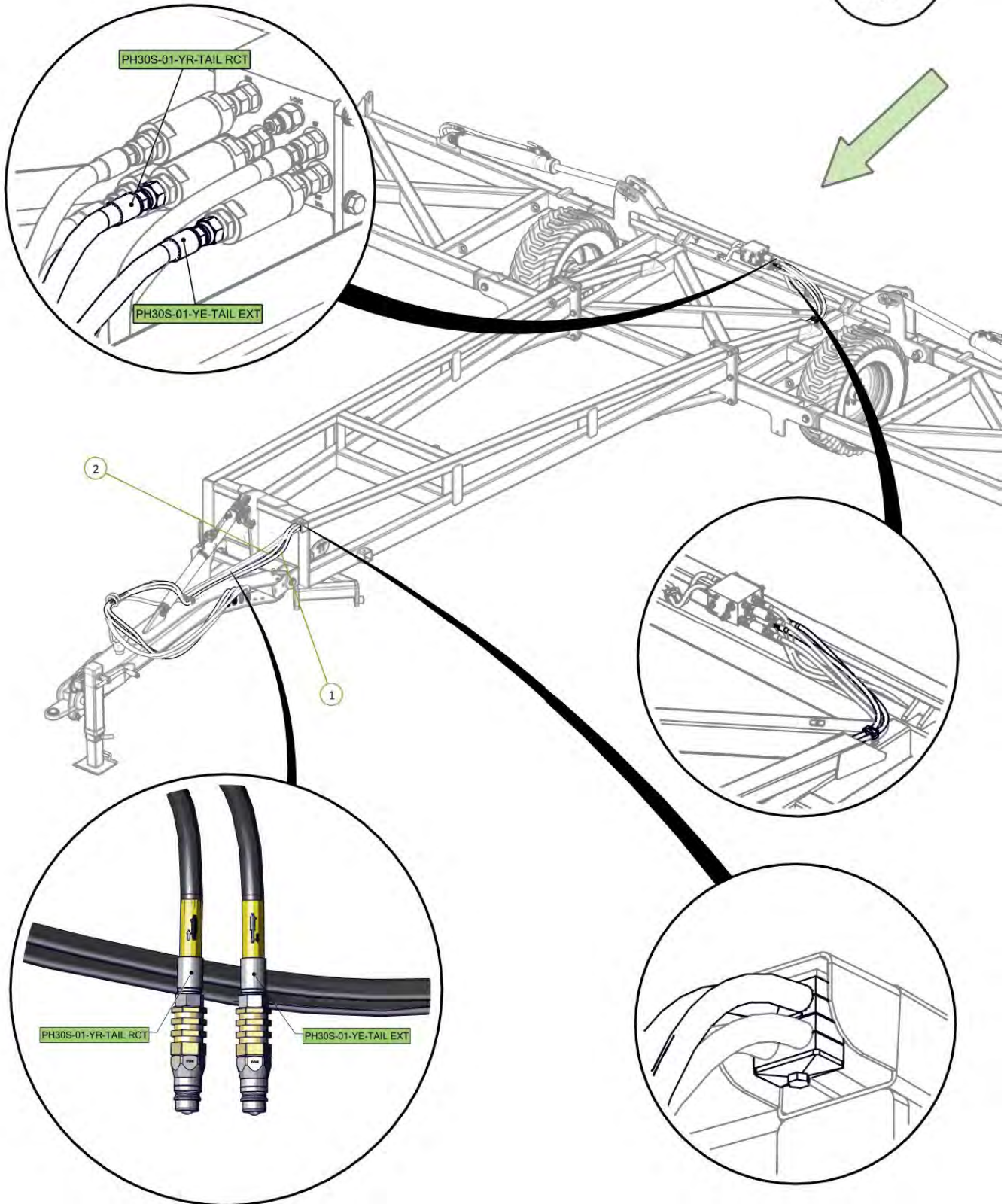

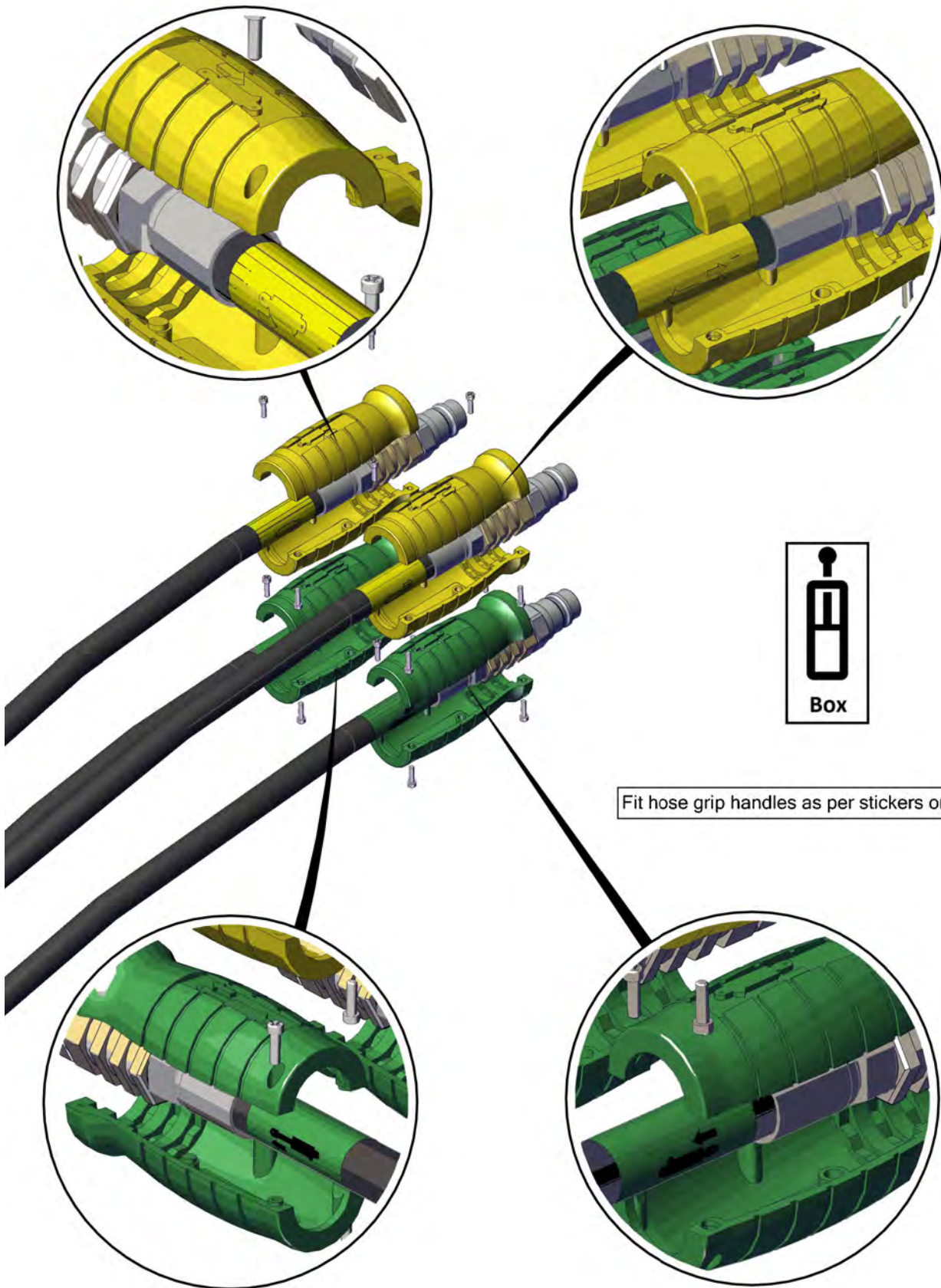

Fit hose grip handles as per stickers on hoses

Item No.	Description	Number	Qty
1	3/4" JIC Male 3/4" UN O Ring Male 90° Elbow	0323-S91-1212	2

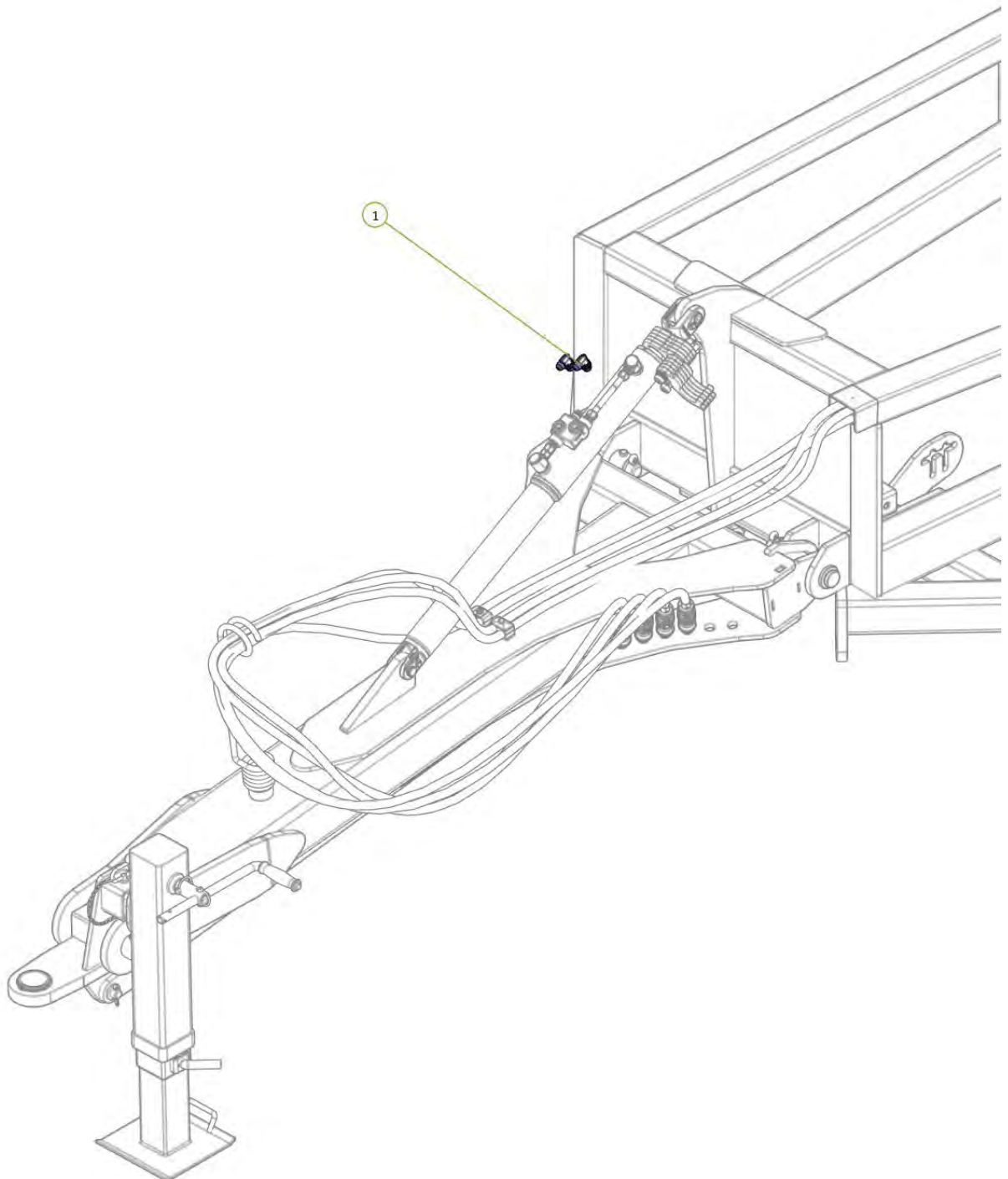
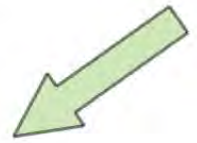
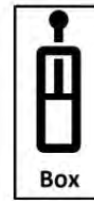

Item No.	Description	Number	Qty
1	Tractor to Front Lift Cylinder Extend Port fitted with Blue Extend Grip	PH30S-02-BE-EXT	1
2	Tractor to Front Lift Cylinder Retract Port fitted with Blue Retract Grip	PH30S-02-BR-RCT	1

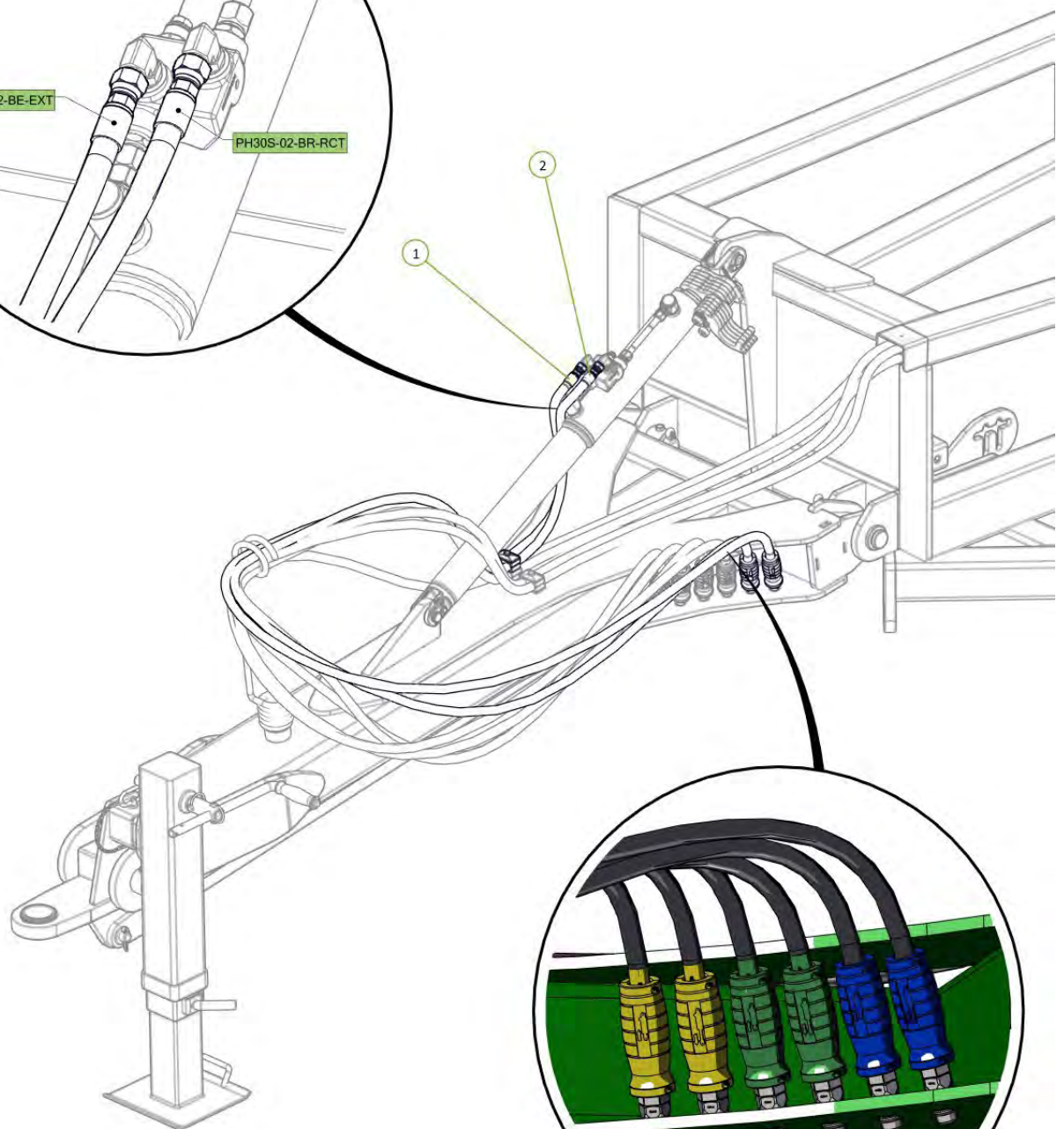
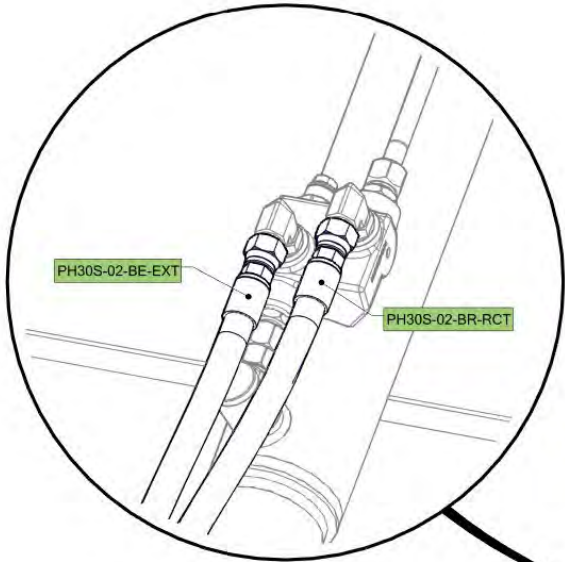
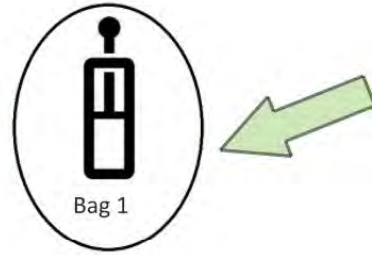

Item No.	Description	Number	Qty
1	30' Rear A-Frame	0830-03-2	1
2	Tail Frame Pivot pin	0801-10-08-175	2
3	Nyloc Nut M12	0221-NYL12	2
4	M12 x 80 Class 8.8 ZP Bolt	0211-1280	2
5	Cotter Pin M13 x 63	0261-PINC1363	2

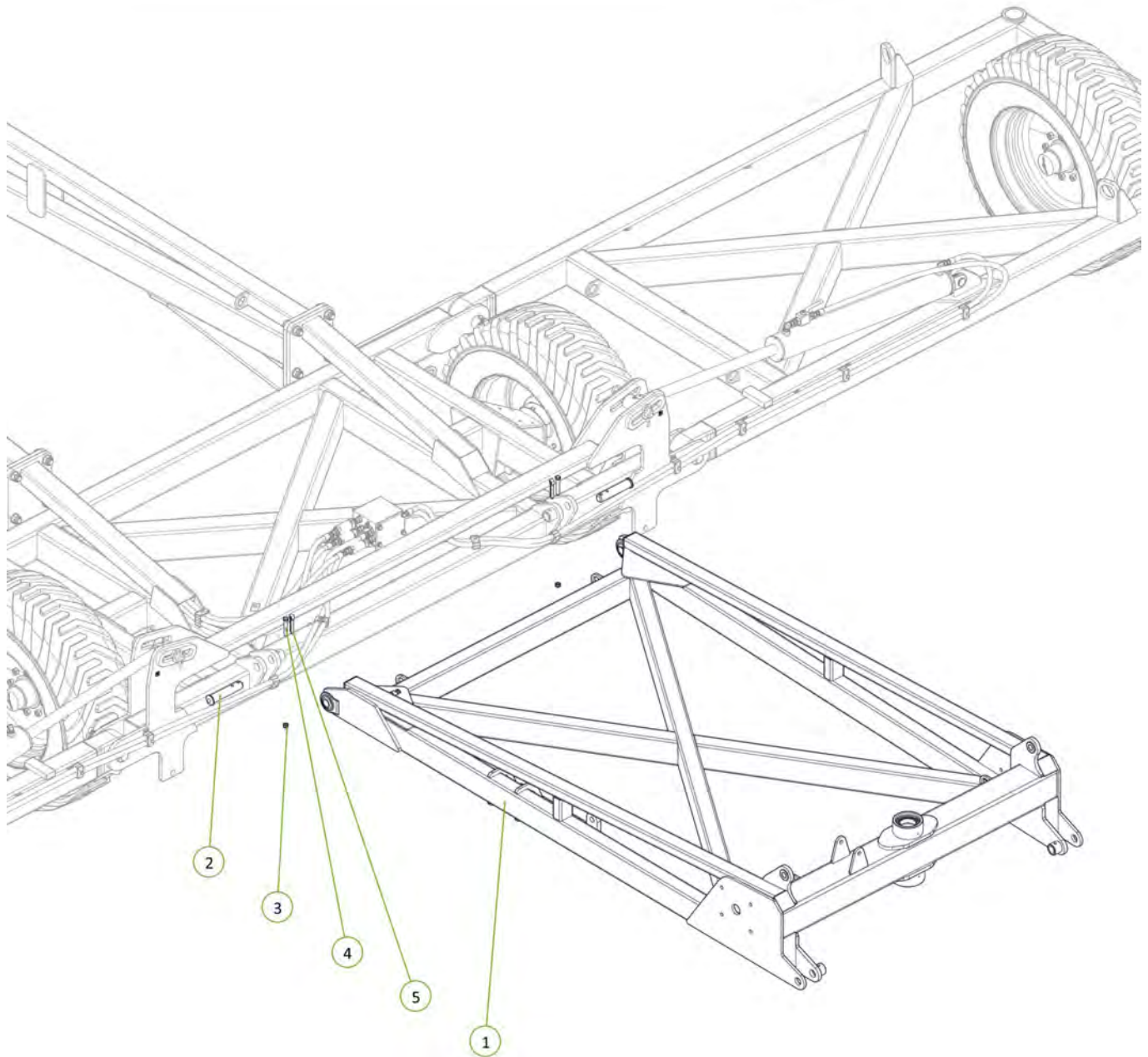

Item No.	Description	Number	Qty
1	70mm Jockey Wheel (Sleeved)	1610-12-70	1
2	Plain Spherical Bearing 70mm	0113-GE70DO-2RS	2
3	Circlip Internal 105mm	0171-J105	2
4	TC Seal 90mm x 125mm x 13mm	0121-TC12681	1
5	Circlip External 70mm	0172-D1400-0700APP	1
6	Grease Nipple 1/4" UNF 45°	0181-GN1/445	2

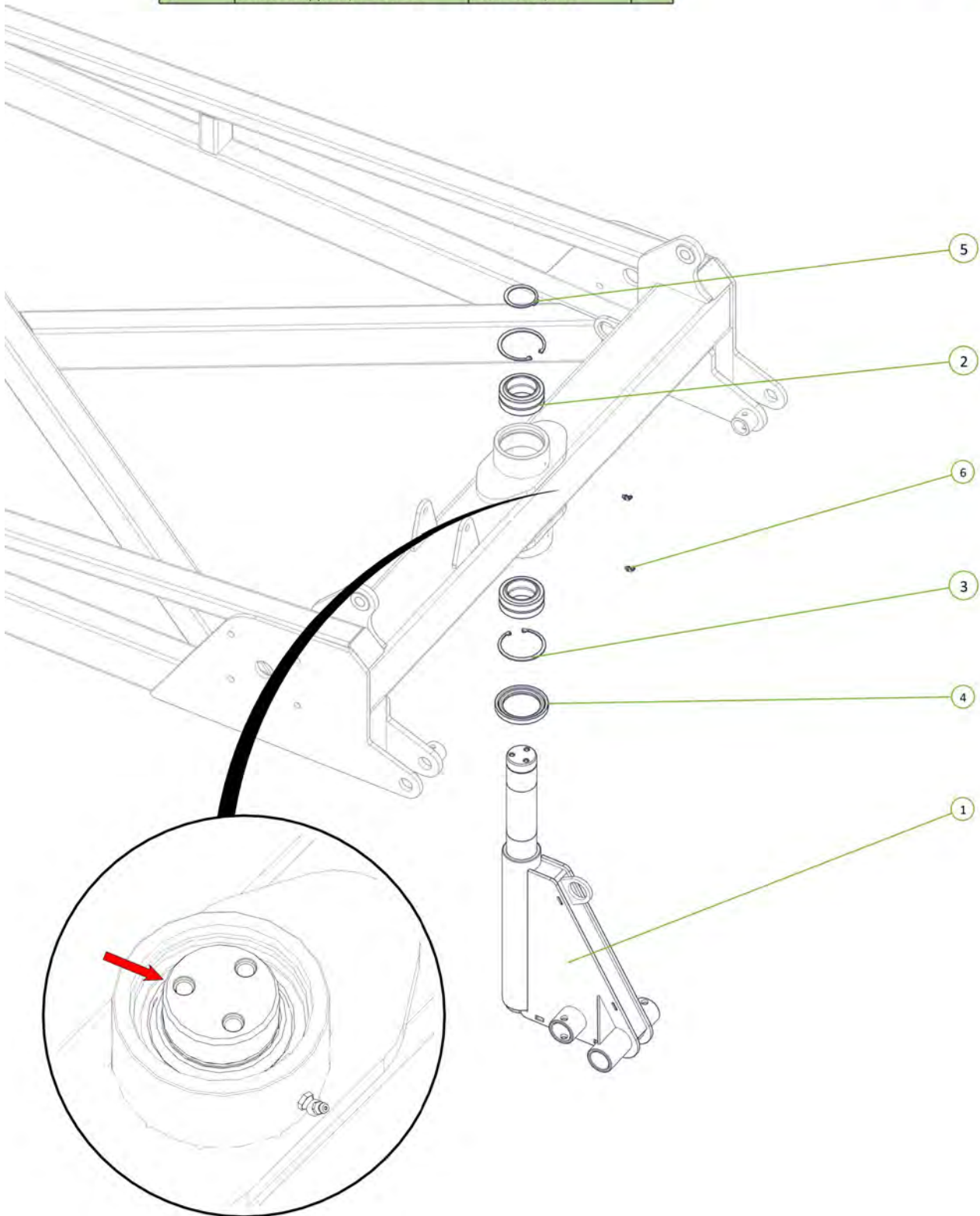

Item No.	Description	Number	Qty
1	Brake Disc	1600-405	1
2	M12 x 24 Wheel Bolt	0216-WB1224	3
3	Seal 70 x 100 x 10mm	0121-TC12654	1

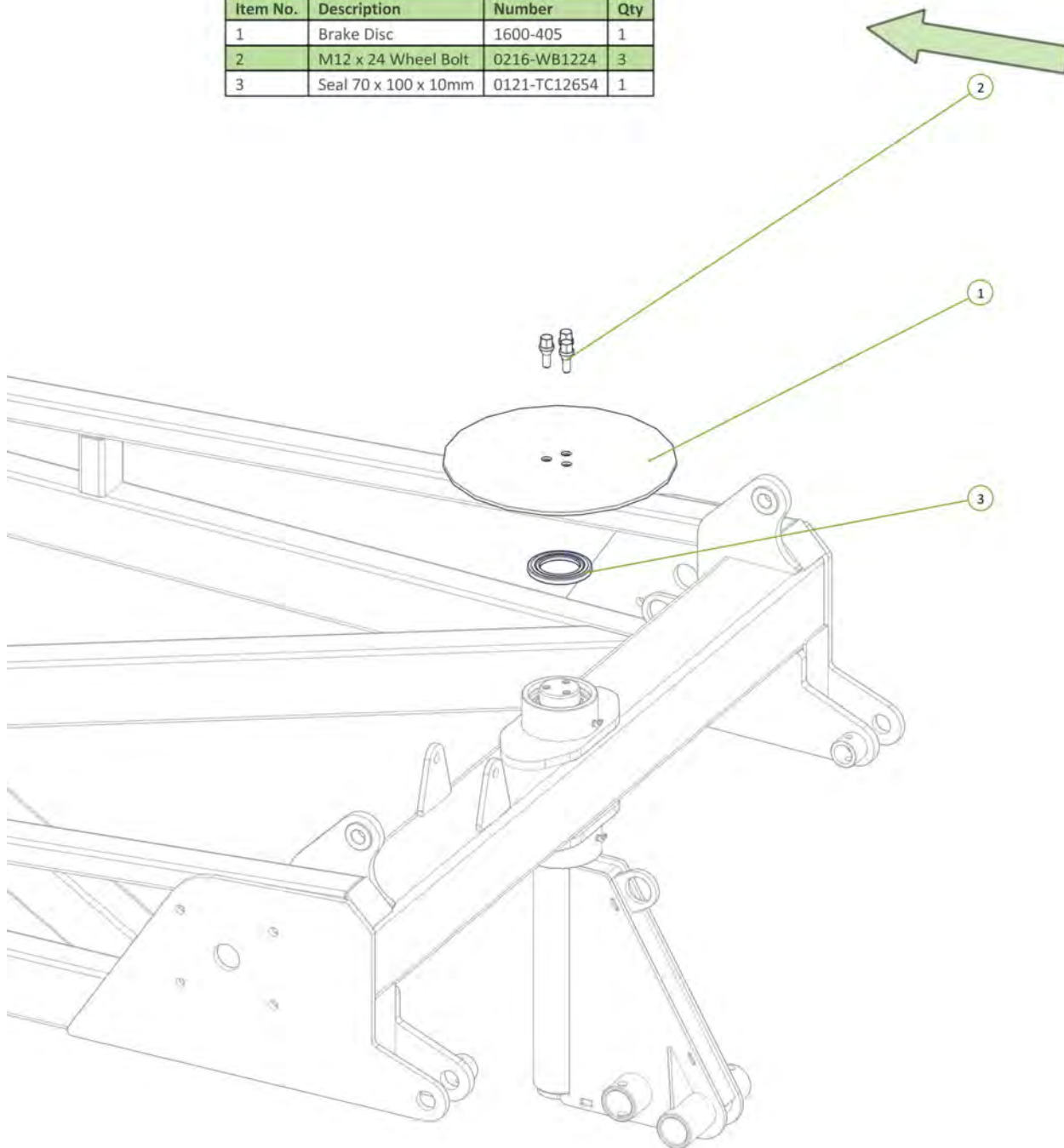

Torque wheel bolts to 65ft-lb / 88Nm

Item No.	Description	Number	Qty
1	Jockey Wheel Brake Caliper	0810-12CALA	1
2	Brake Compression Spring	0801-KE009	1
3	Washer Square M16 x 50 x 5	0231-SQ16505	1
4	Brake Spring Indicator	0800-772	1
5	M16 x 150 Class 8.8 ZP Bolt	0211-16150	1
6	M16 x 160 Class 8.8 ZP Bolt	0211-16160	1
7	Washer Flat M16	0231-F16	2
8	Nyloc Nut M16	0221-NYL16	1

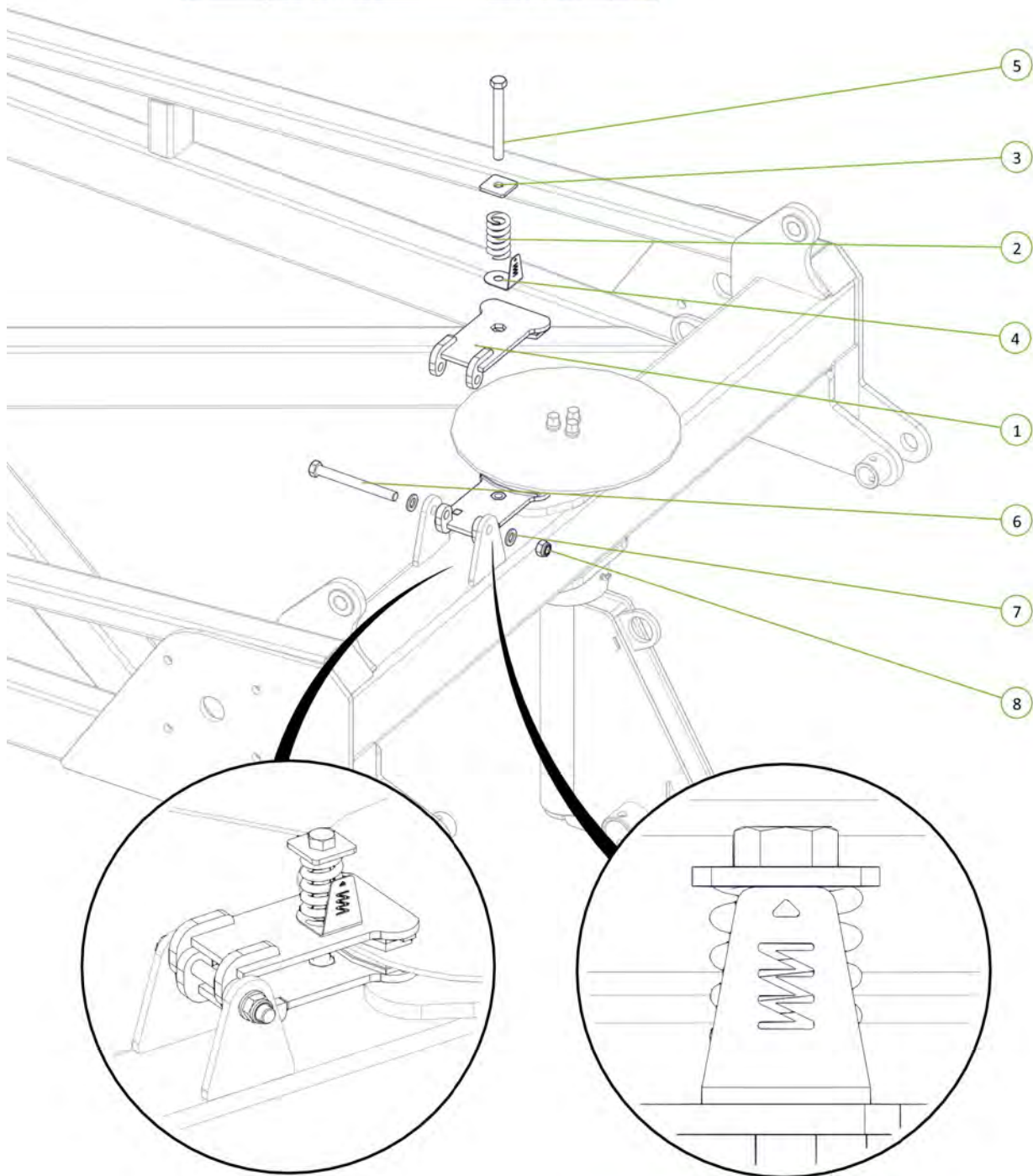

Compress spring to top of Indicator as shown

Item No.	Description	Number	Qty
1	Axle 2"R 3T 6 on 6" PCD 330 OHF	0733-K5083T66S	2
2	M16 x 90 grade 8.8 zp Bolt	0211-16	2
3	Nyloc Nut M16	0221-NYL16	2

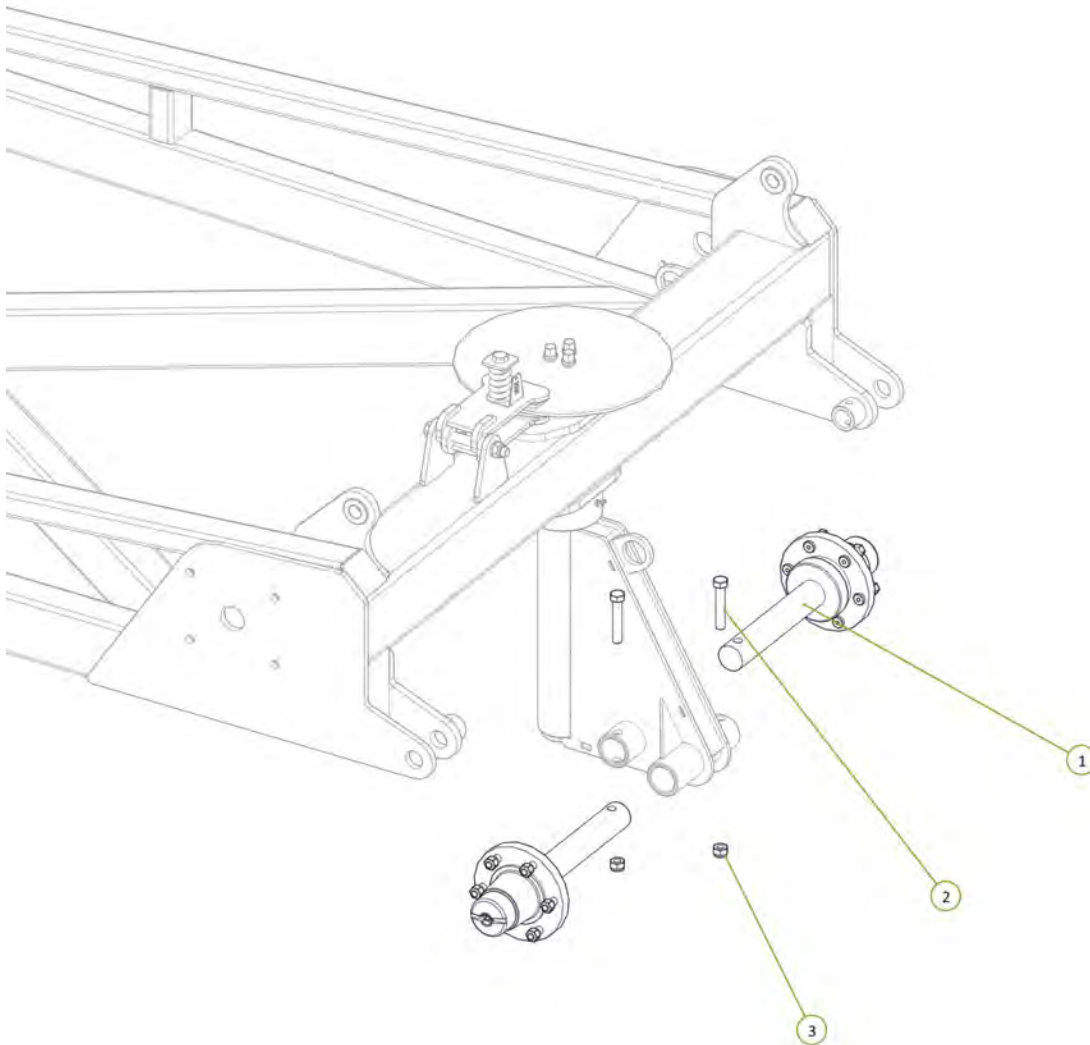

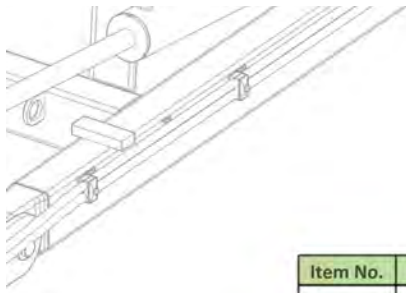

Item No.	Description	Number	Qty
1	11L15 F3 Tyre on 6 on 6" Stud Rim	0751-11L15	2

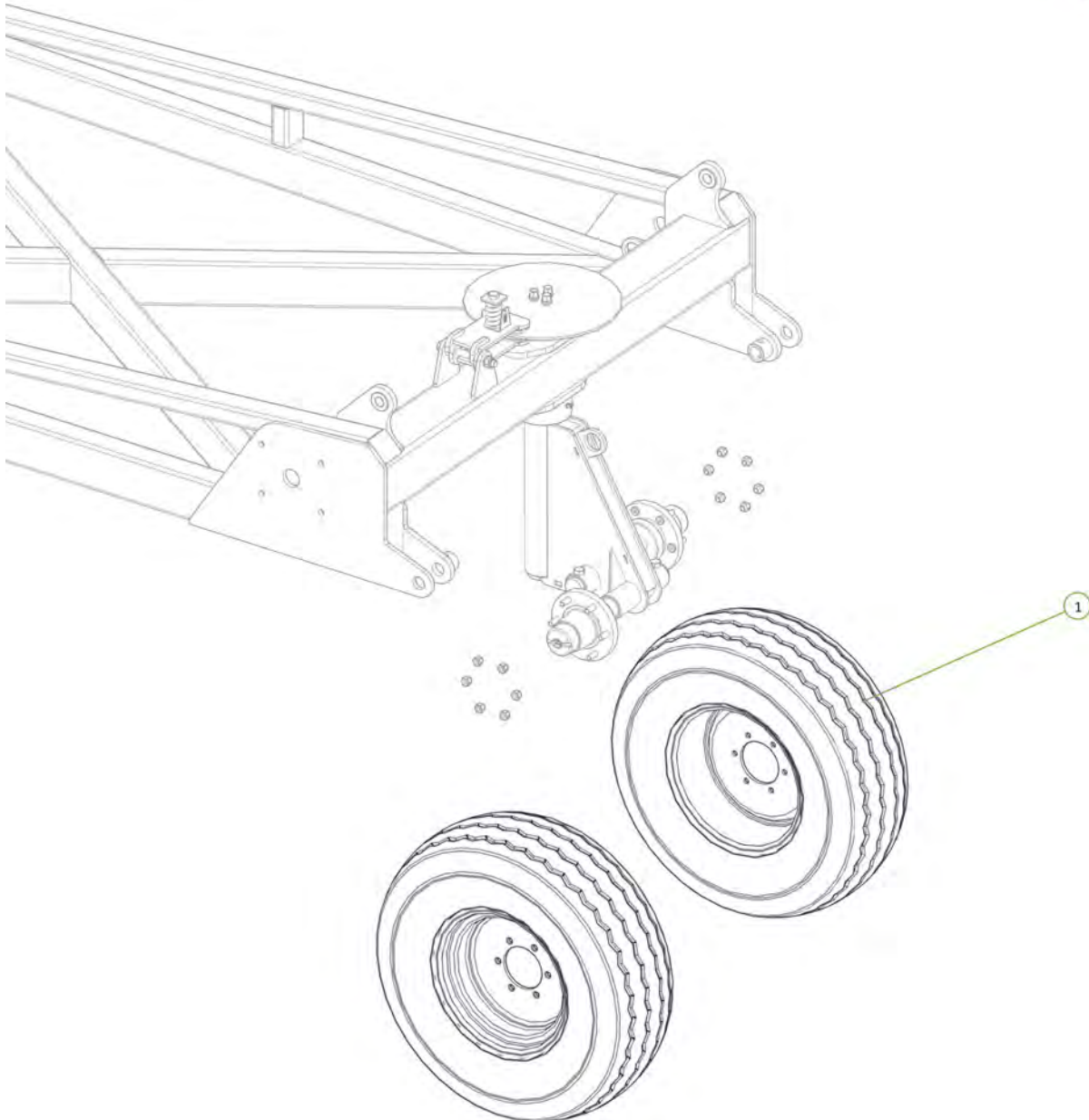

Torque wheel nuts to 90ft-lb / 125Nm

Item No.	Description	Number	Qty
1	Extended Tip Rear Tail	0810-10E	1
2	Tail Frame Pivot pin	0801-10-08-175	2
3	M12 x 80 Class 8.8 ZP Bolt	0211-1280	2
4	Nyloc Nut M12	0221-NYL12	2
5	Cotter Pin M13 x 63	0261-PINC1363	2

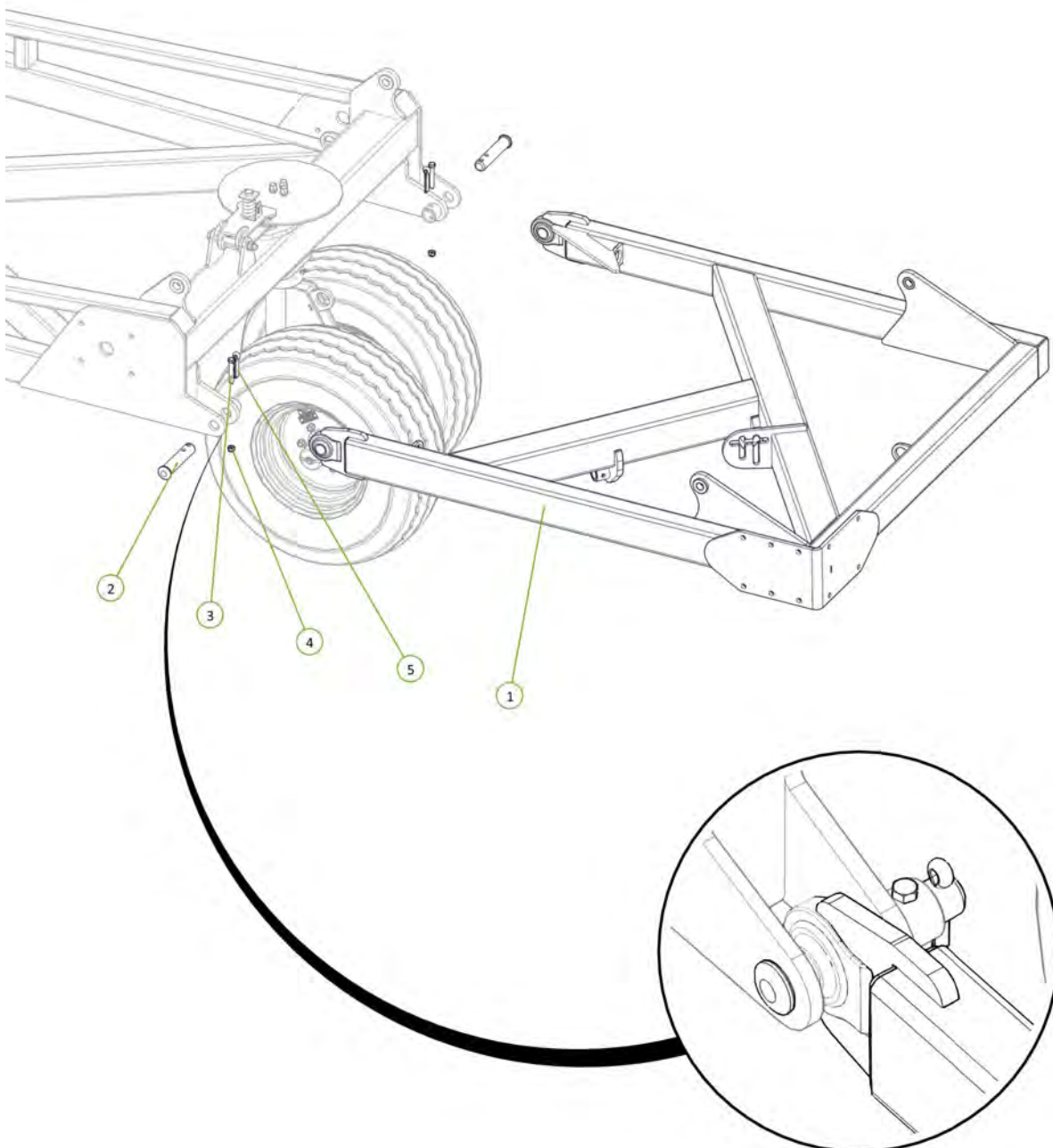

Item No.	Description	Number	Qty
1	3.5" Bore x 24" Stroke 1.75" Rod Side Port Cylinder	0311-3524SP	2

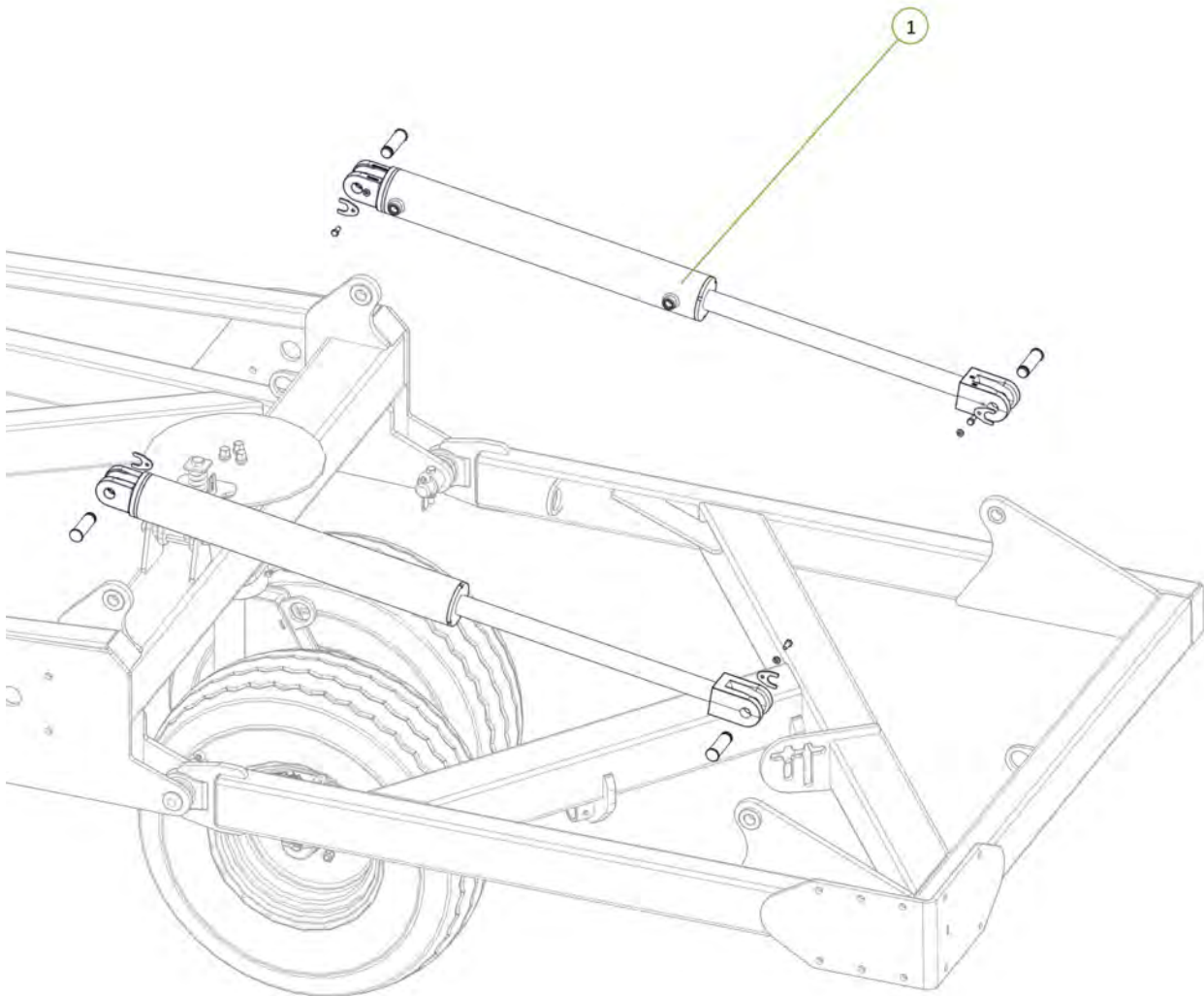

Item No.	Description	Number	Qty
1	3/4" JIC Male 3/4" UN O Ring Male 90° Elbow	0323-S91-1212	4

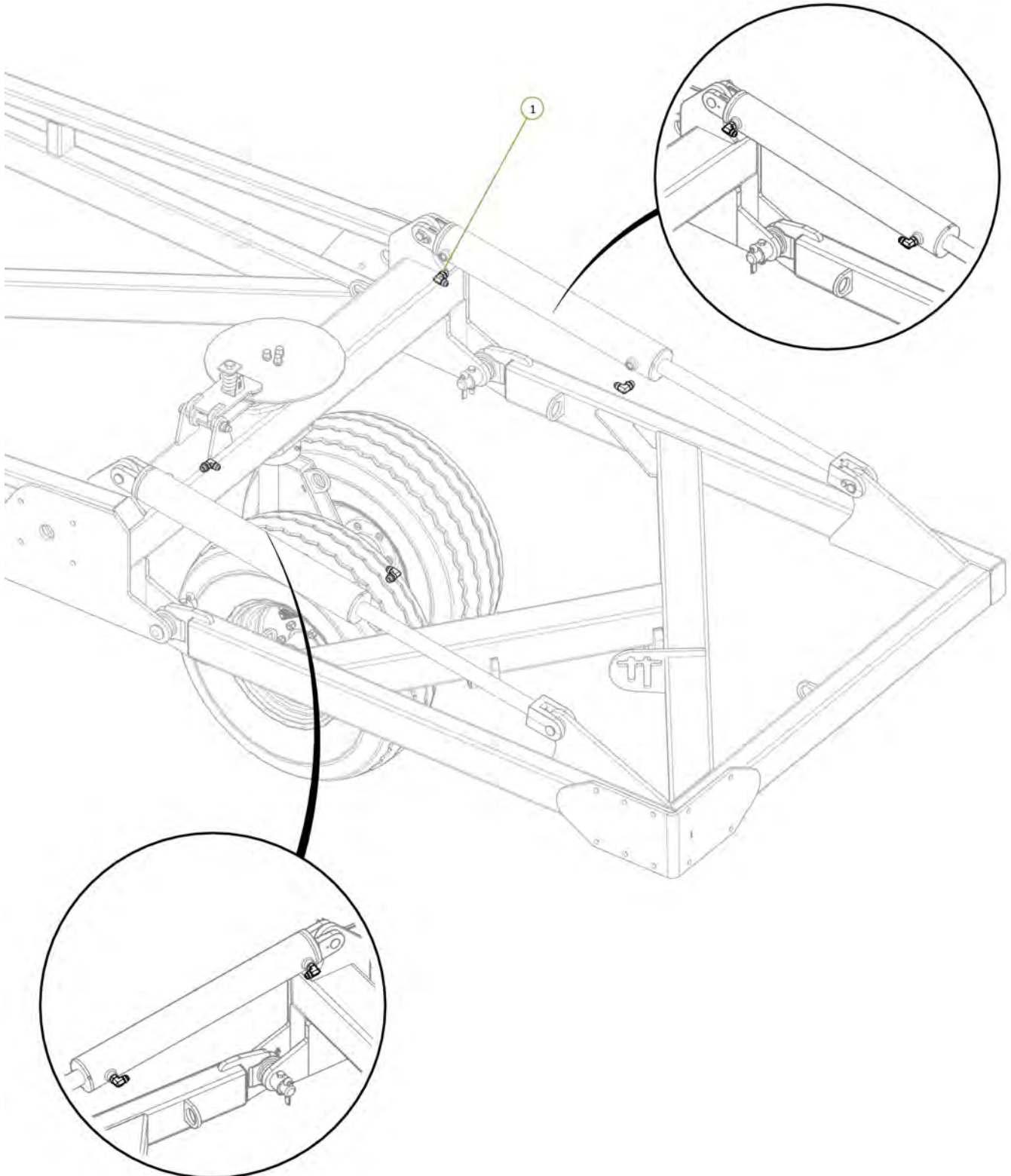
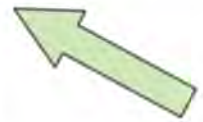

Item No.	Description	Number	Qty
1	Valve TE Port to Tail Extend Tee	PH30S-05	1
2	Valve TR Port to Tail Retract Tee	PH30S-06	1
3	3/4" JIC Male Tee 3/4" JIC Male Tee 3/4" JIC Male Tee	0324-S19-121212	2

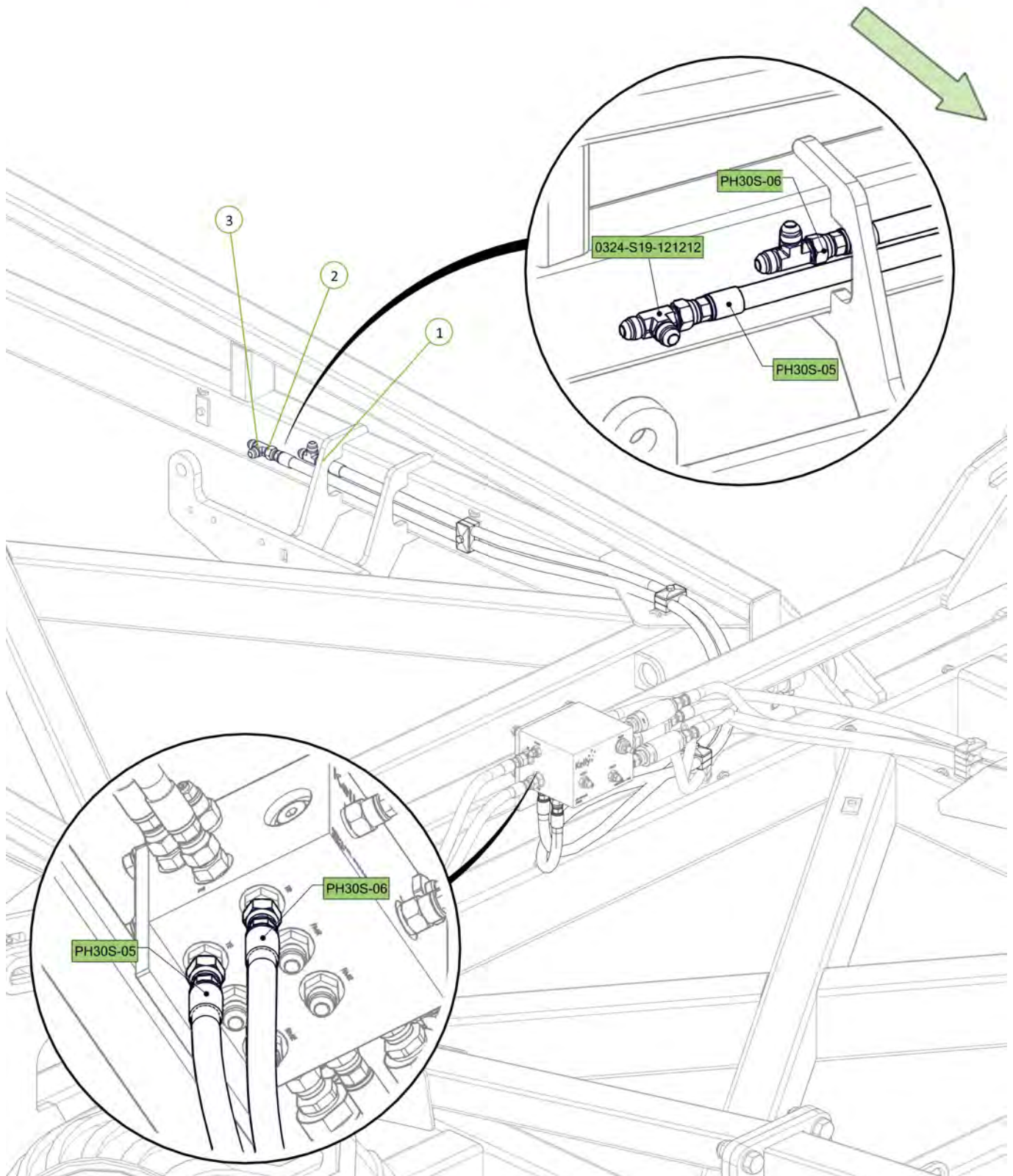

Item No.	Description	Number	Qty
1	Tail Extend Tee to Rear Extend Tee	PH30S-07	1
2	Tail Retract Tee to Rear Retract Tee	PH30S-08	1
3	3/4" JIC Male Tee 3/4" JIC Male Tee 3/4" JIC Male Tee	0324-S19-121212	2

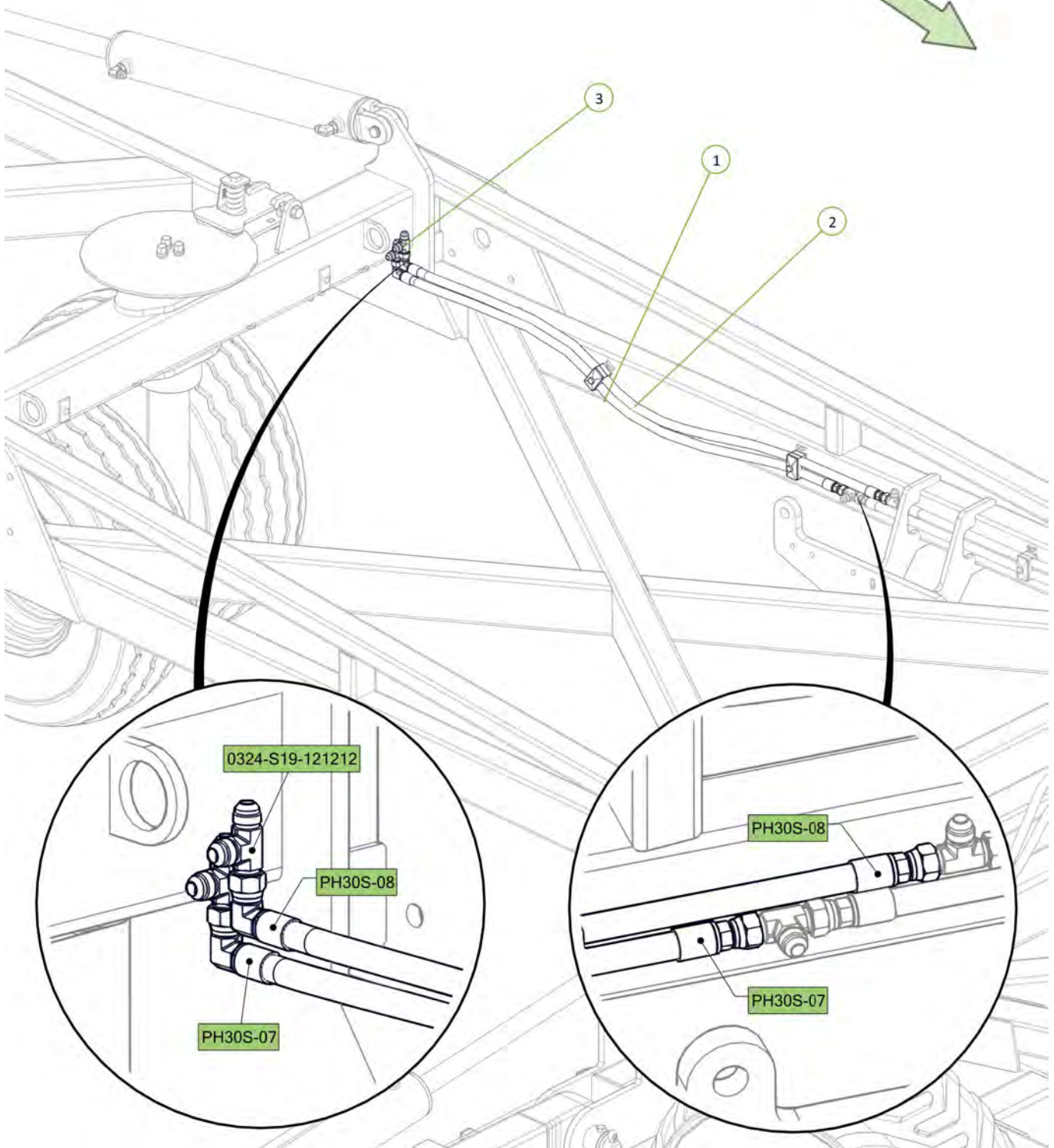

Item No.	Description	Number	Qty
1	Rear Extend Tee to Rear Port LH Tail Cylinder	PH30S-09	1
2	Rear Retract Tee to Rod Port Tail LH Cylinder	PH30S-10	1

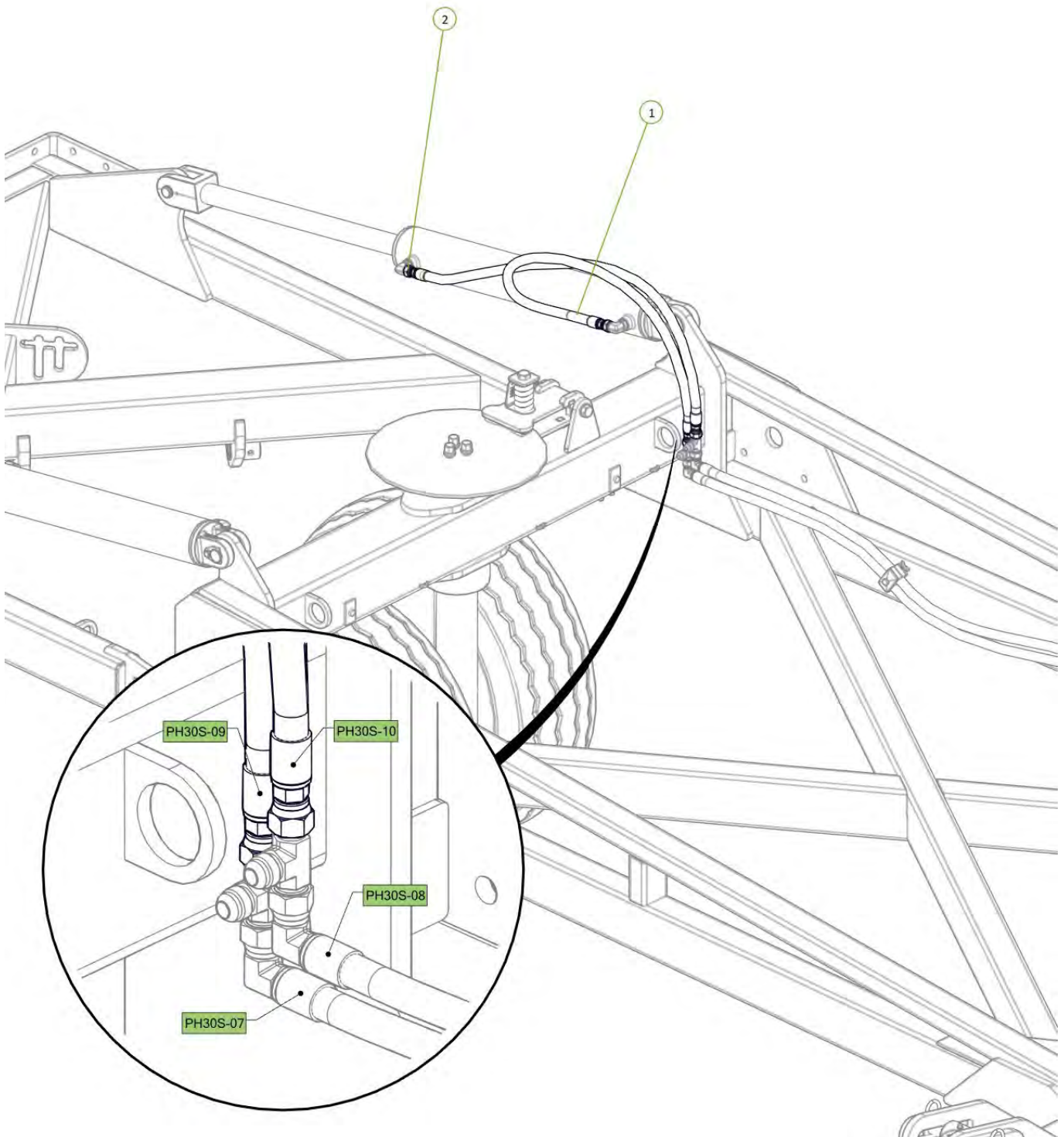

Item No.	Description	Number	Qty
1	Rear Extend Tee to Rear Port RH Tail Cylinder	PH30S-11	1
2	Rear Retract Tee to Rod Port RH Tail Cylinder	PH30S-12	1

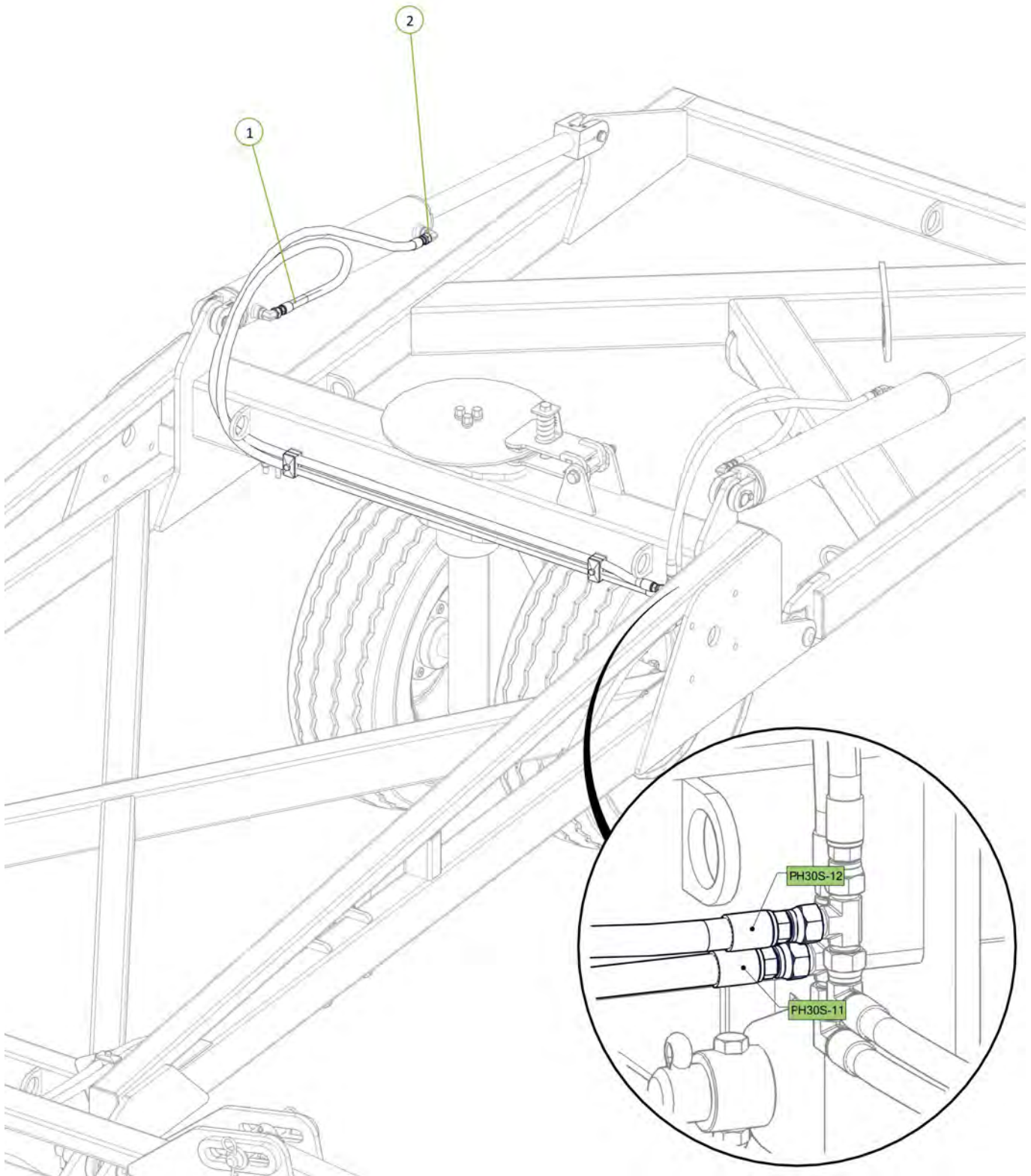

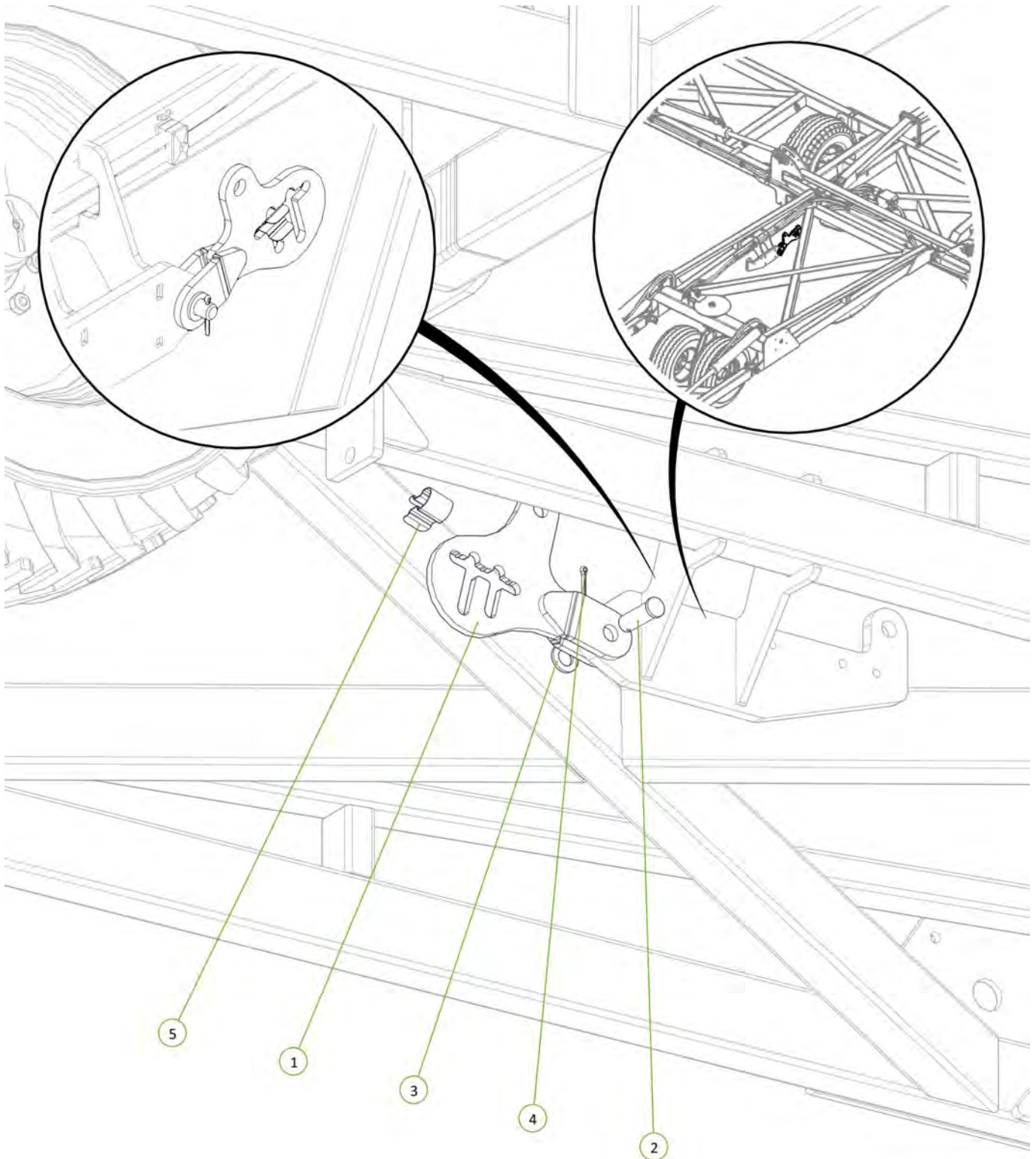

Item No.	Description	Number	Qty
1	Reduced Lift Arm	0810-84	1
2	Clevis Pin 25mm x 75mm	0801-KE0307-1	1
3	Washer Flat M24	0231-F24	1
4	Cotter Pin M5 x 50	0261-PINC550	1
5	Height Adjustor Retaining Clip	0801-KE014	1



Item No.	Description	Number	Qty
1	2.5" Bore x 6" Stroke 1.5" Rod Side Port Cylinder	0311-256SP	1

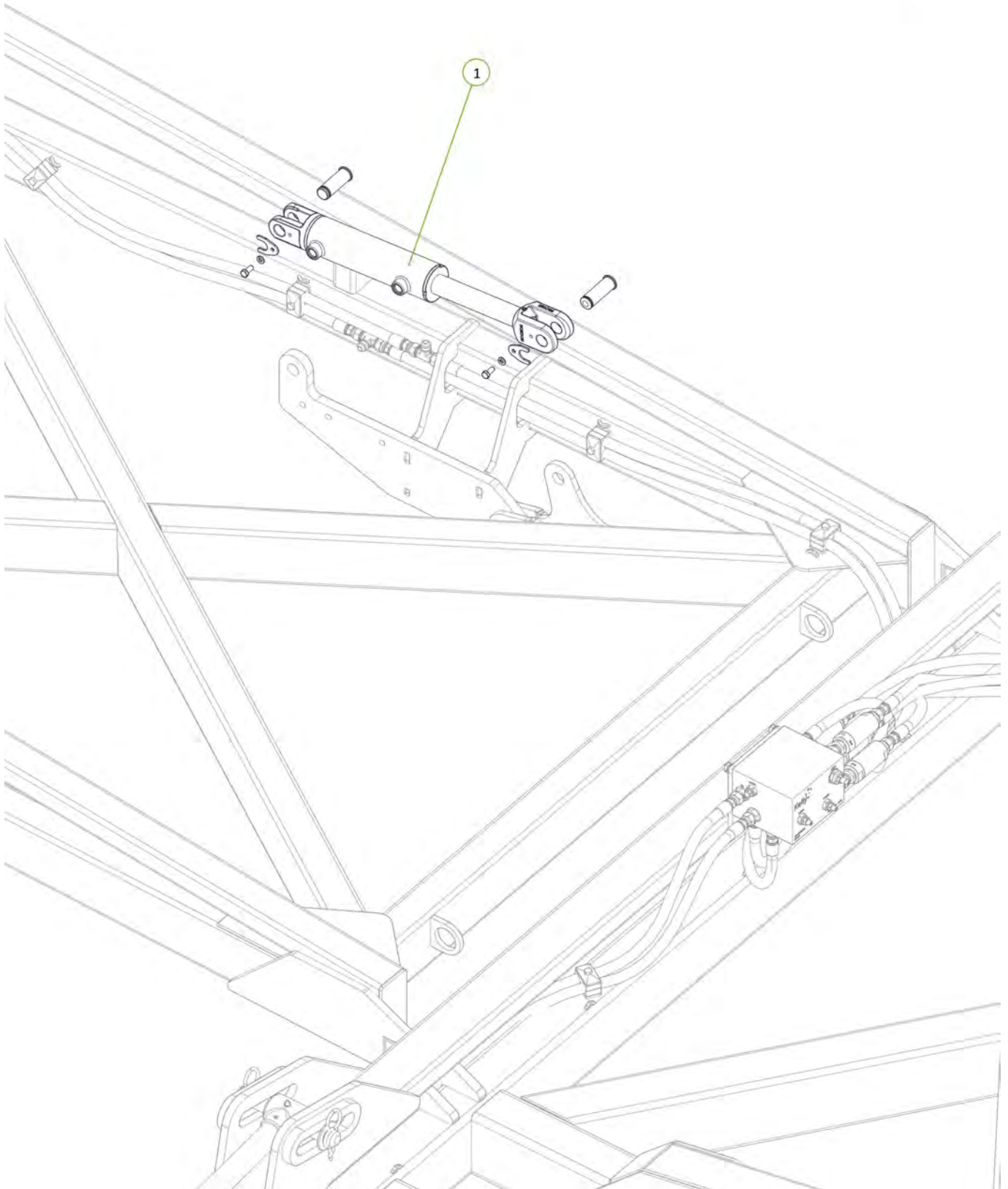
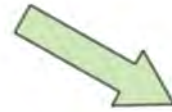

Item No.	Description	Number	Qty
1	3/4" JIC Male 3/4" UN O Ring Male 90° Elbow	0323-S91-1212	2

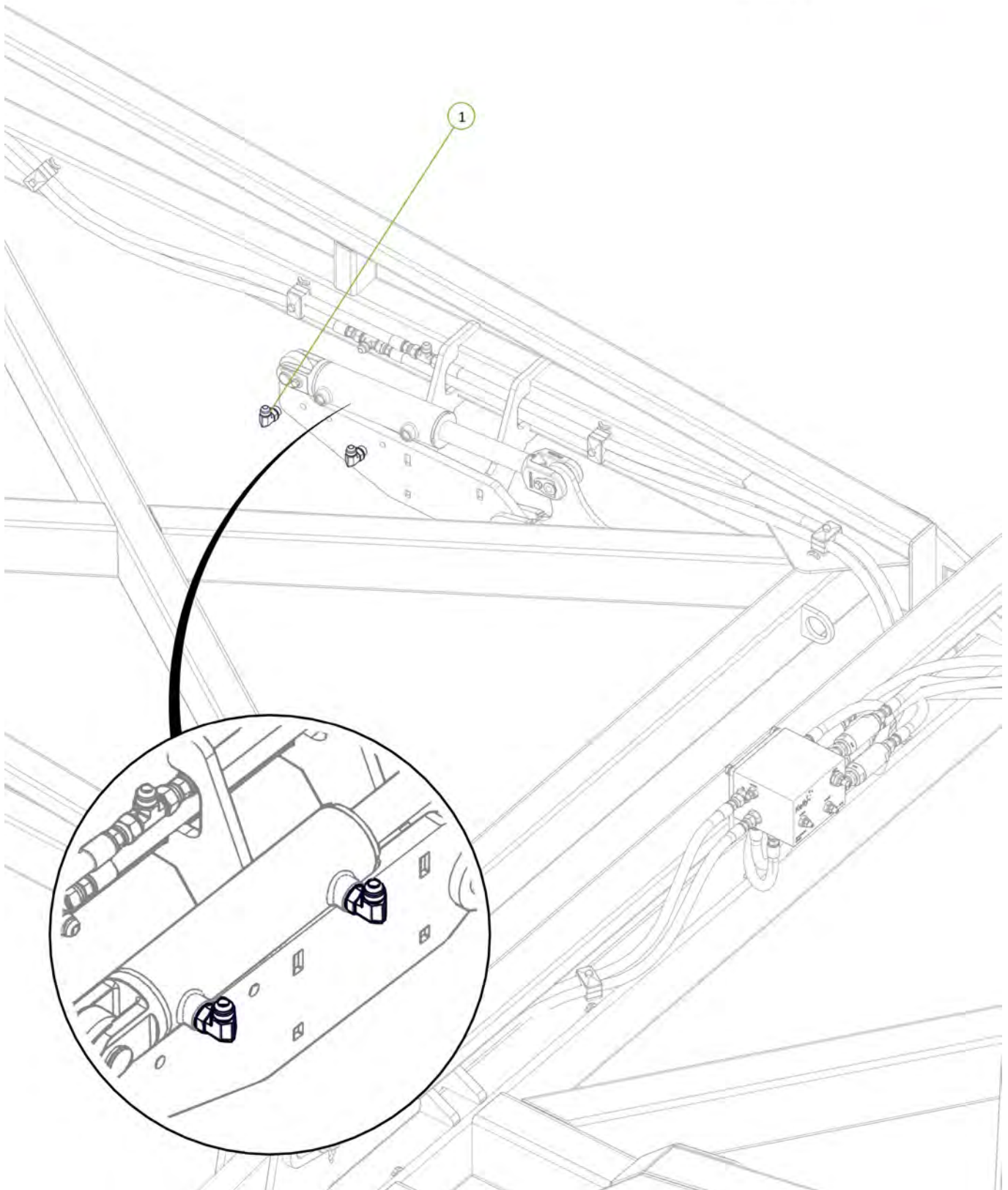

Item No.	Description	Number	Qty
1	Tail Extend Tee to Rear Port Left Rear Module Cylinder	PH30S-13	1
2	Tail Retract Tee to Rod Port Left Rear Module Cylinder	PH30S-14	1

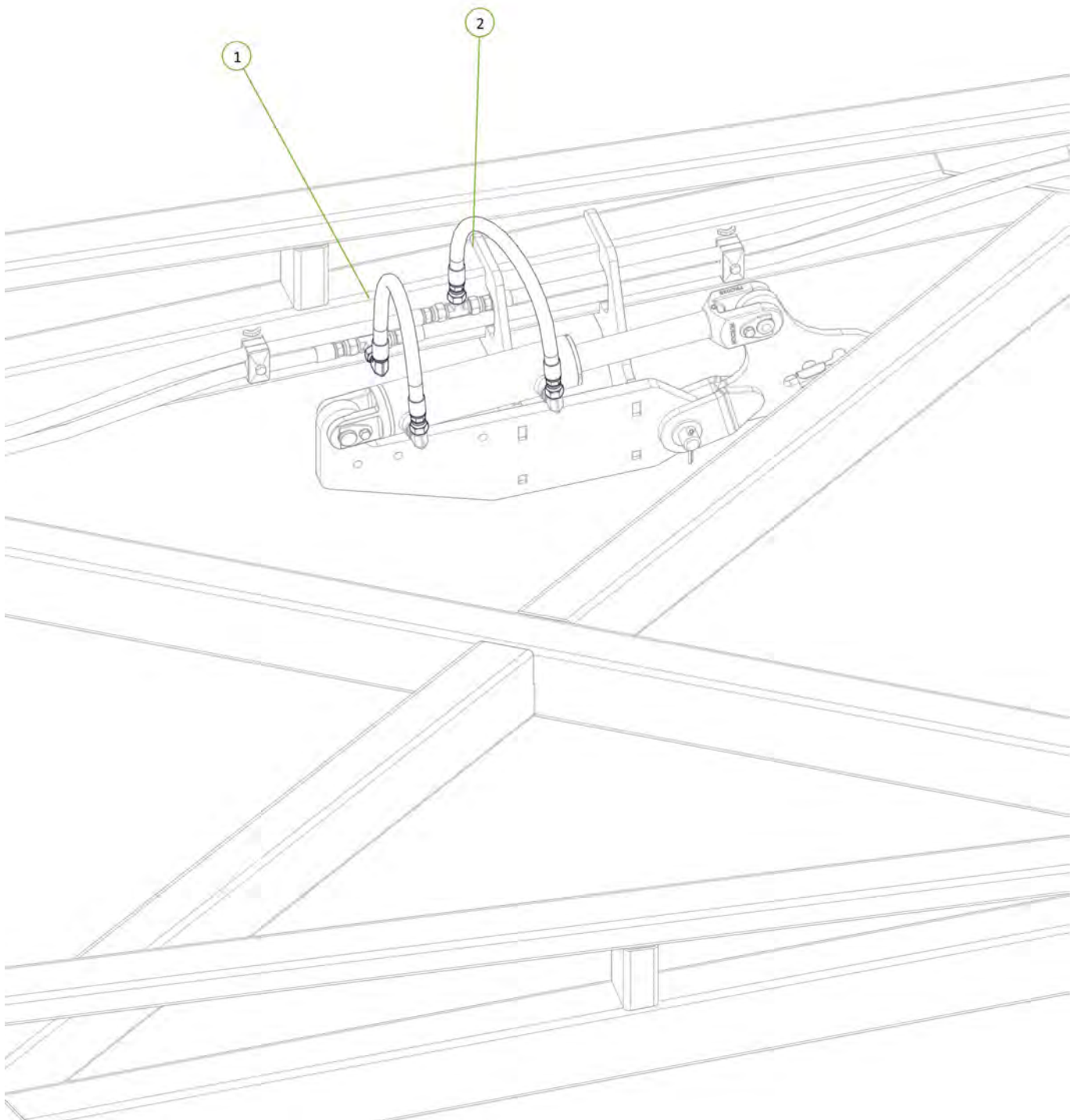

Item No.	Description	Number	Qty
1	Extended Tip Tail Bolt On Tip	0810-10ET	1
2	M16 x 50 grade 8.8 zp Bolt	0211-1650	9
3	Nyloc Nut M16	0221-NYL16	10
4	Washer Flat M16	0231-F16	20

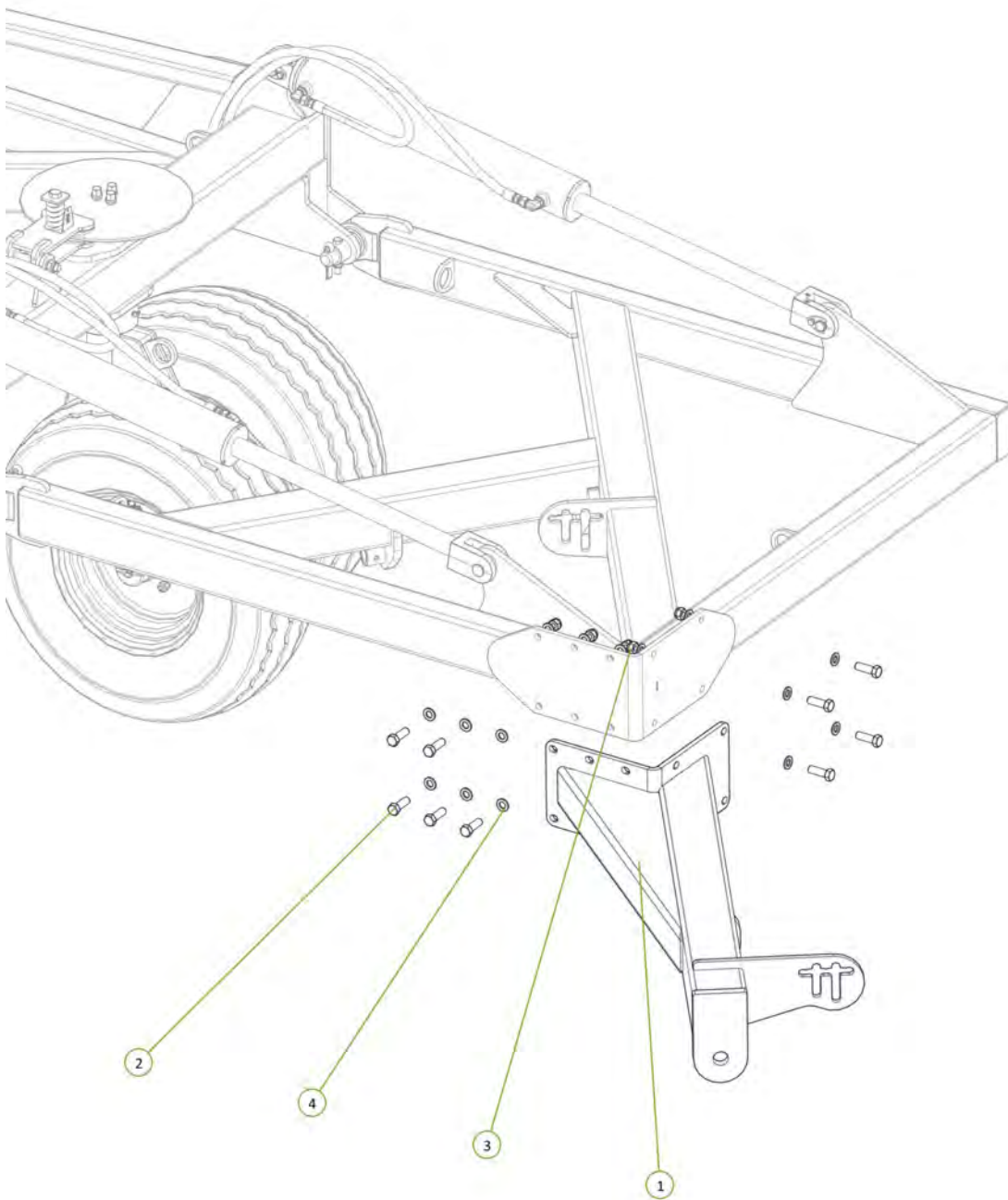

Item No.	Description	Number	Qty
1	30' Front Module	0810-28-30-2	1
2	U-Bolt M16 x 190 Deep X 106 Wide	0271-16185104	8
3	Nyloc Nut M16	0221-NYL16	16
4	Washer Flat M16	0231-F16	16

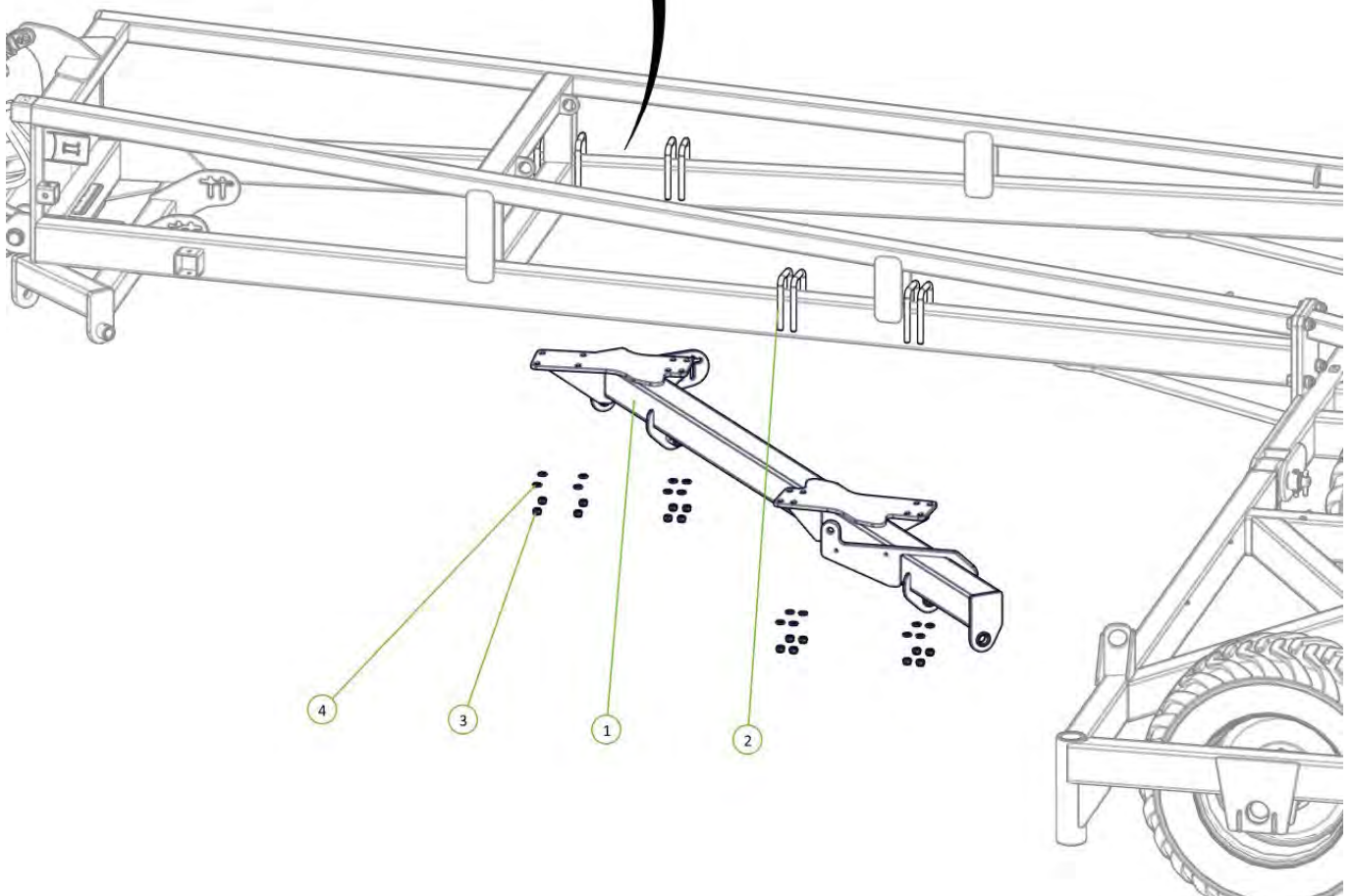
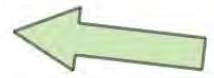

Item No.	Description	Number	Qty
1	30' Rear Module	0810-29-30-2	1
2	U-Bolt M16 x 160 Deep X 77 Wide	0271-1616077	7
3	Washer Flat M16	0231-F16	14
4	Nyloc Nut M16	0221-NYL16	14

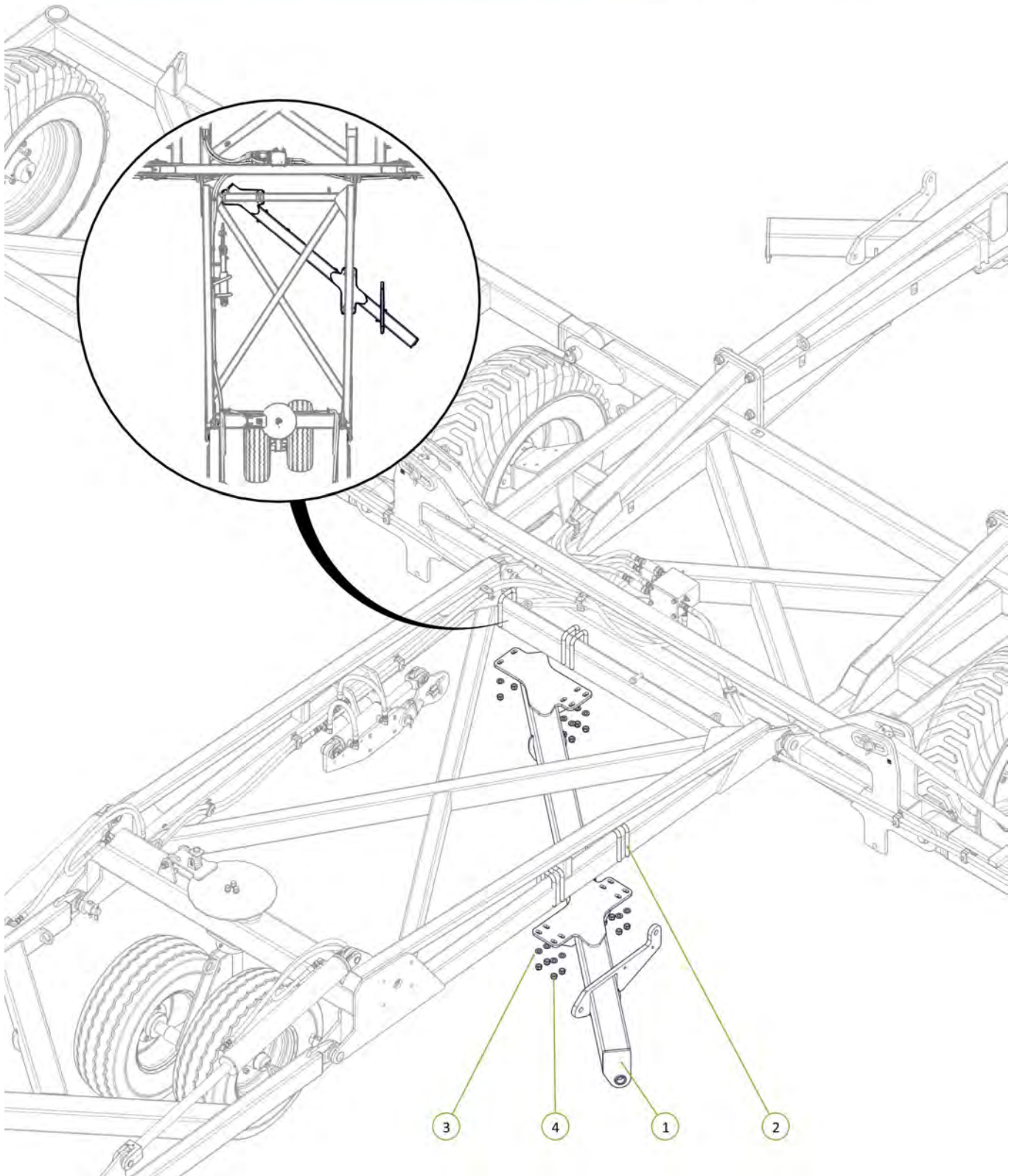

Item No.	Description	Number	Qty
1	Super Single LH Drop Leg No Clevis	0810-24SF	1
2	Super Single RH Drop Leg No Clevis	0810-25SF	1
3	LH Chain Adjusting Lug	0810-26	1
4	RH Chain Adjusting Lug	0810-27	1
5	Forged Clevis 21mm Bolt Hole	0801-FC21	2
6	M36 x 110 grade 8.8 zp Bolt	0211-36105	2
7	M24 x 140 grade 8.8 zp Bolt	0211-24140	2
8	Nyloc Nut M24	0221-NYL24	2
9	Nyloc Nut M36	0221-NYL36	2
10	Stainless Steel Wear Bush	1501-365033-SS	2

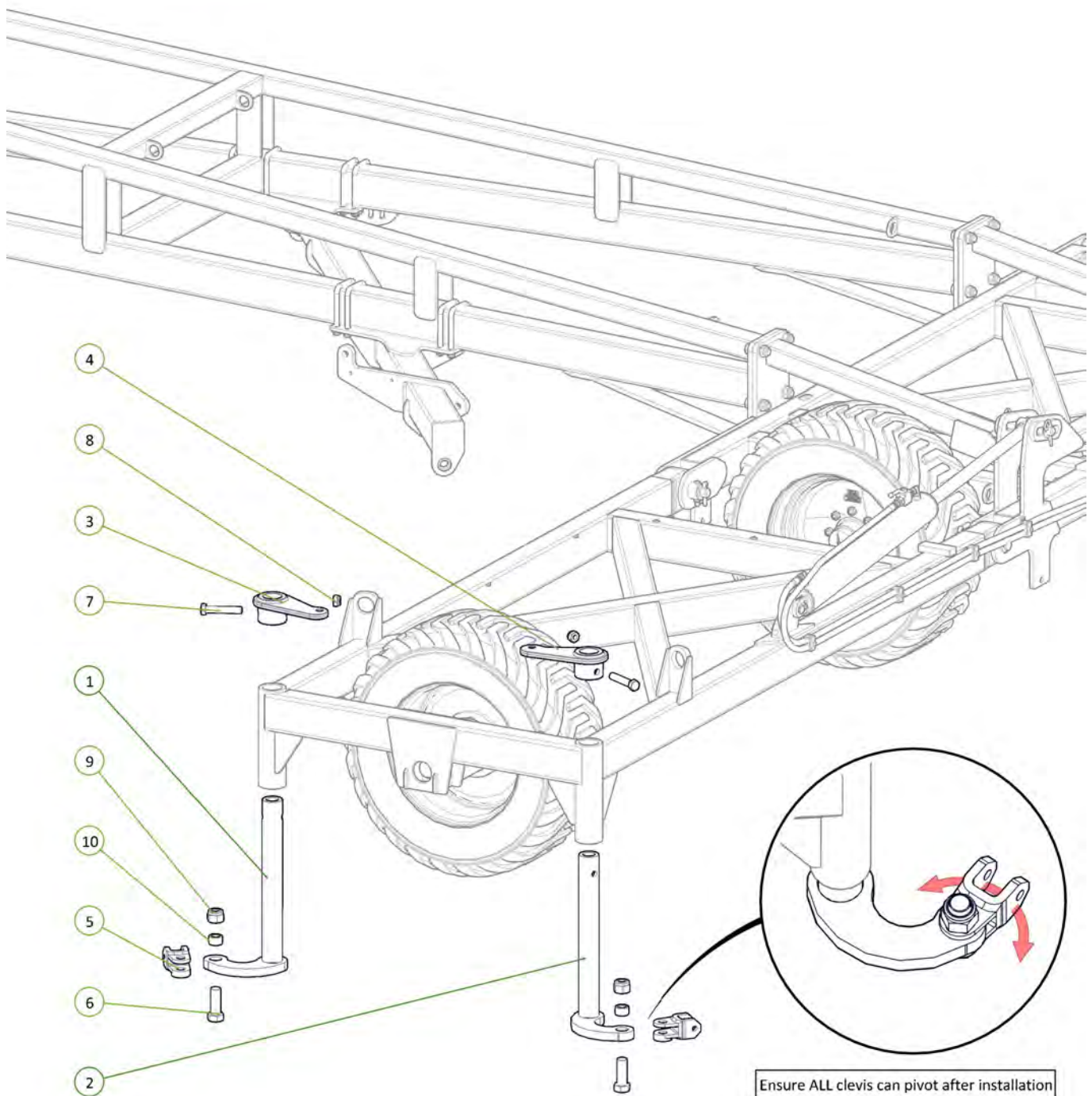

Ensure ALL clevis can pivot after installation

Item No.	Description	Number	Qty
1	Cast 25mm Spacing Half	0801-CS25	24
2	M10 x 30 Class 8.8 ZP Bolt	0211-1030	24
3	Nyloc Nut M10	0221-NYL10	24

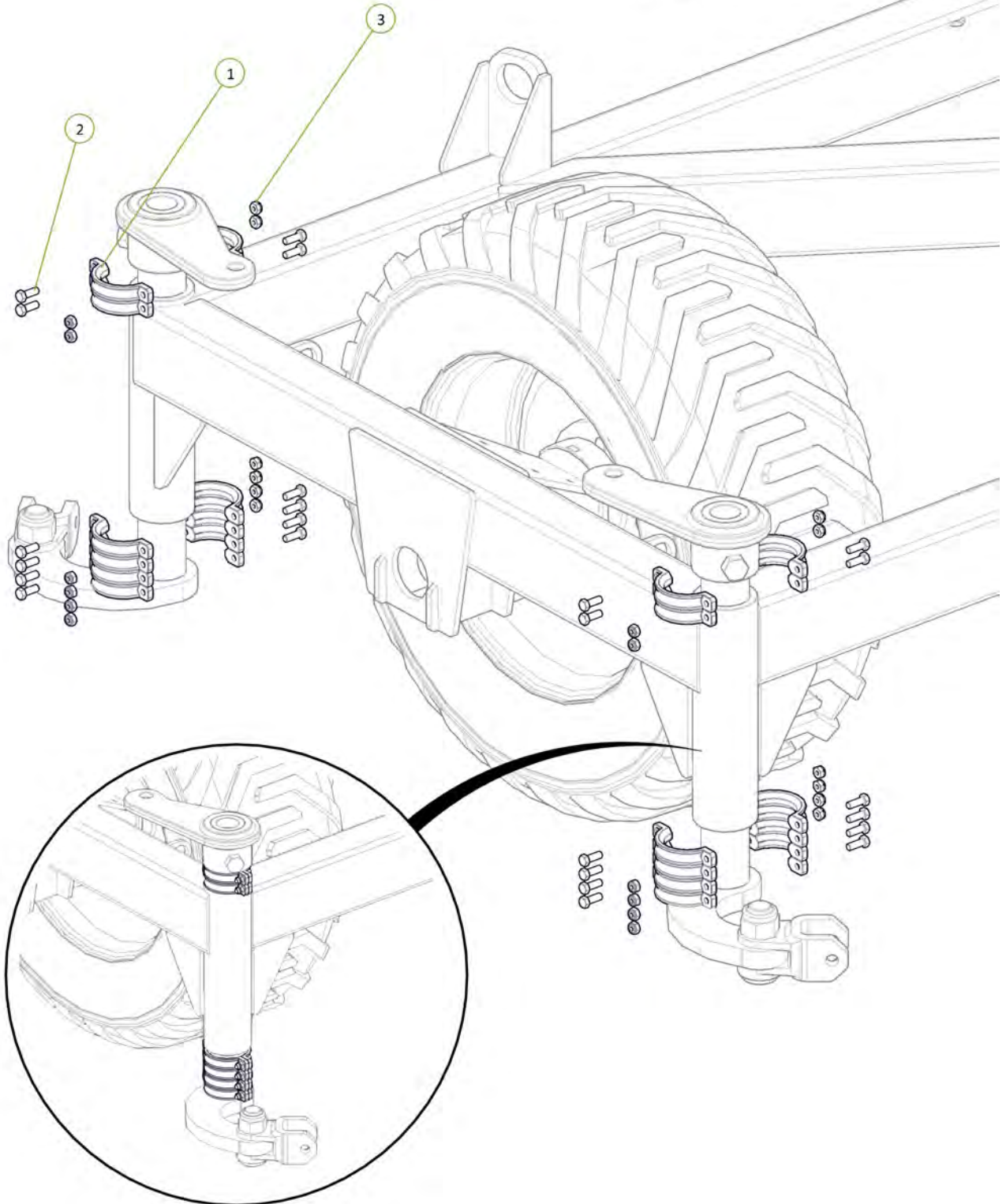

Item No.	Description	Number	Qty
1	Chain Tension Adjustor	0802-PCHTA	2
2	Washer High Tensile 1 1/4"	0232-HT11-4	2
3	20mm Compression Spring	0801-XK9261S	2
4	Tensioner Cup - Male	0801-KE0805-3	2
5	Female Spring Locator	0801-KE0805-4	2
6	330mm Spring Tension Indicator	0800-758	2

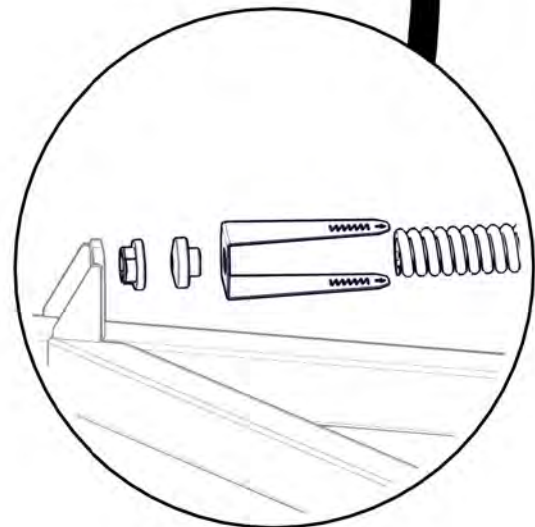
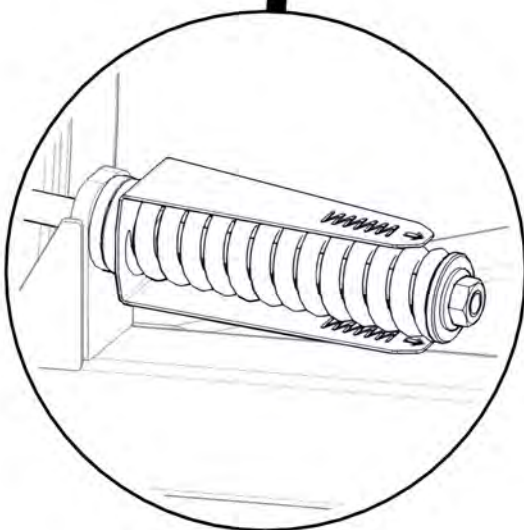
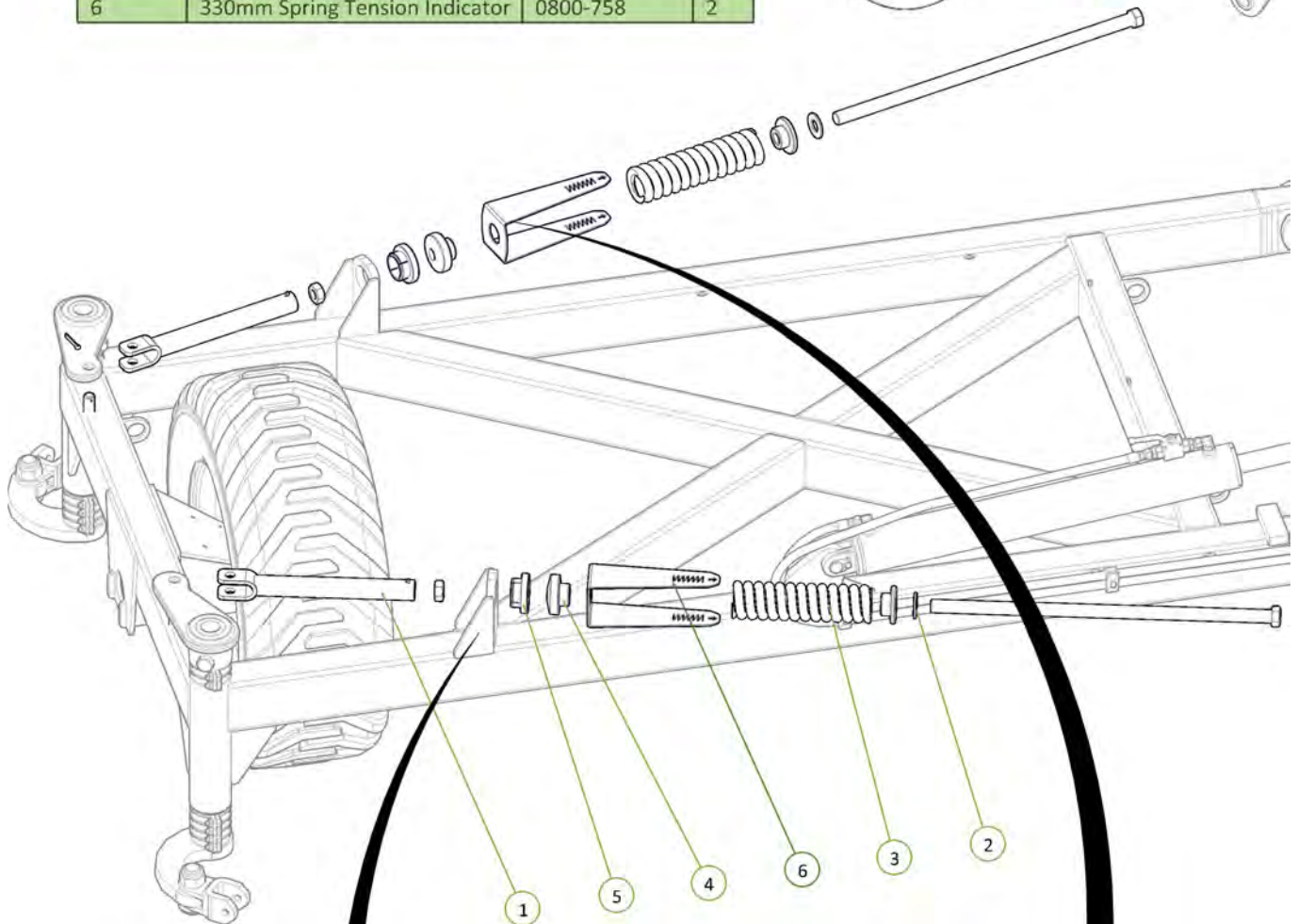

Item No.	Description	Number	Qty
1	Super Single LH Drop Leg No Clevis	0810-24SF	1
2	Super Single RH Drop Leg No Clevis	0810-25SF	1
3	LH Chain Adjusting Lug	0810-26	1
4	RH Chain Adjusting Lug	0810-27	1
5	Stainless Steel Wear Bush	1501-365033-SS	2
6	Forged Clevis 21mm Bolt Hole	0801-FC21	2
7	M36 x 110 grade 8.8 zp Bolt	0211-36110	2
8	Nyloc Nut M36	0221-NYL36	2
9	M24 x 140 grade 8.8 zp Bolt	0211-24140	2
10	Nyloc Nut M24	0221-NYL24	2

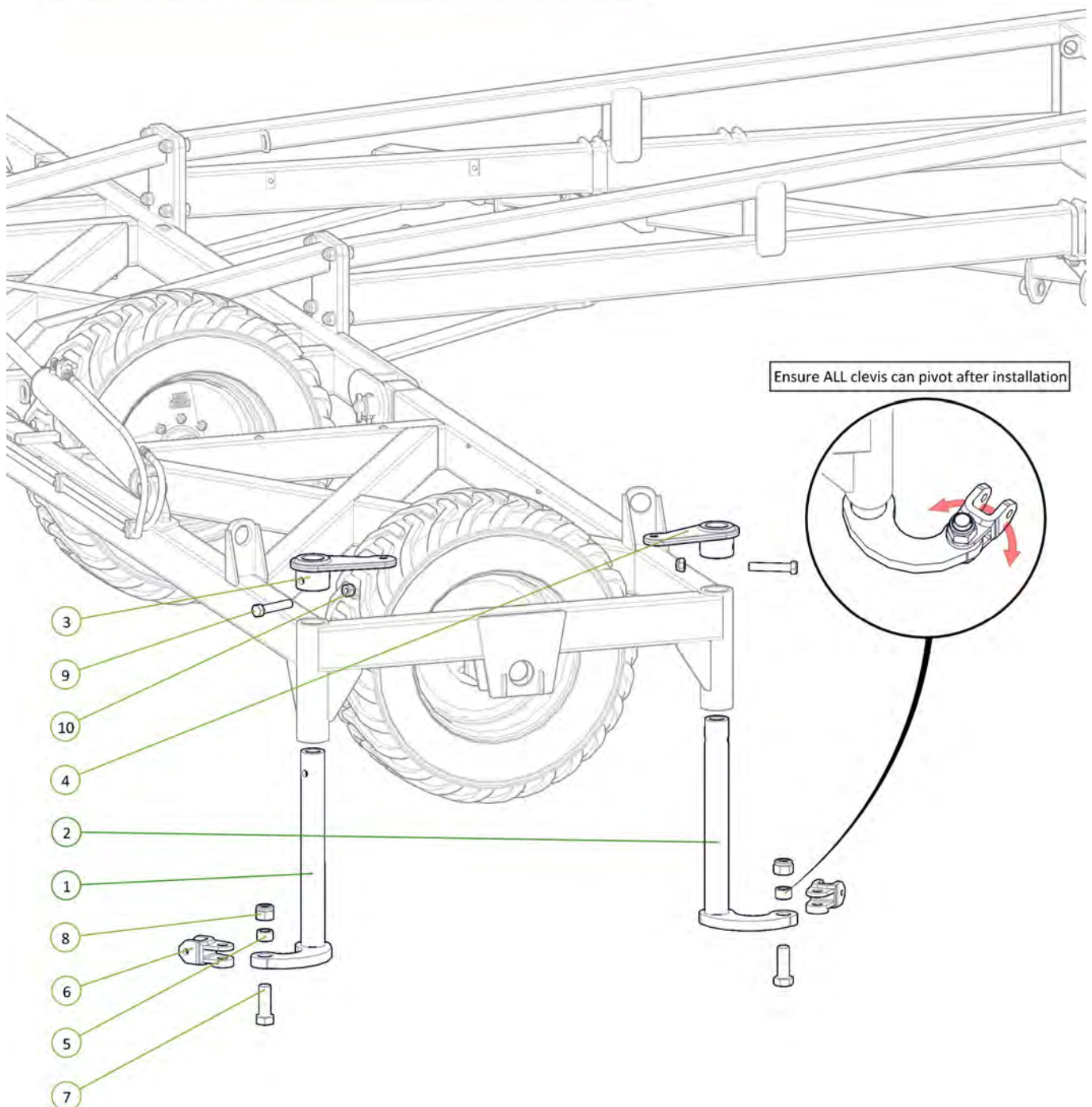

Item No.	Description	Number	Qty
1	Cast 25mm Spacing Half	0801-CS25	24
2	M10 x 30 Class 8.8 ZP Bolt	0211-1030	24
3	Nyloc Nut M10	0221-NYL10	24

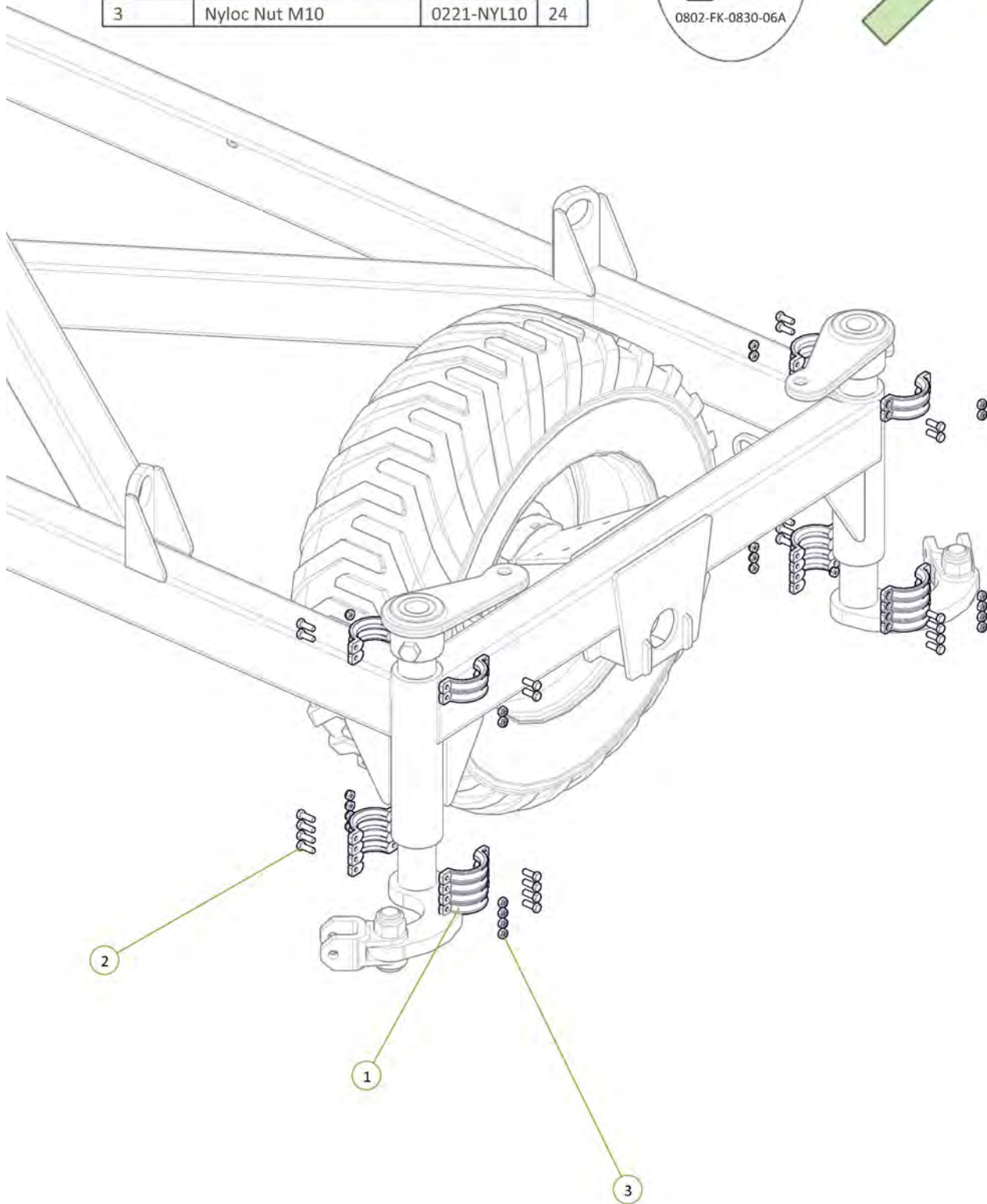

Item No.	Description	Number	Qty
1	Chain Tension Adjustor	0802-PCHTA	2
2	Washer High Tensile 1 1/4"	0232-HT11-4	2
3	20mm Compression Spring	0801-XK9261S	2
4	Tensioner Cup - Male	0801-KE0805-3	2
5	Female Spring Locator	0801-KE0805-4	2
6	330mm Spring Tension Indicator	0800-758	2

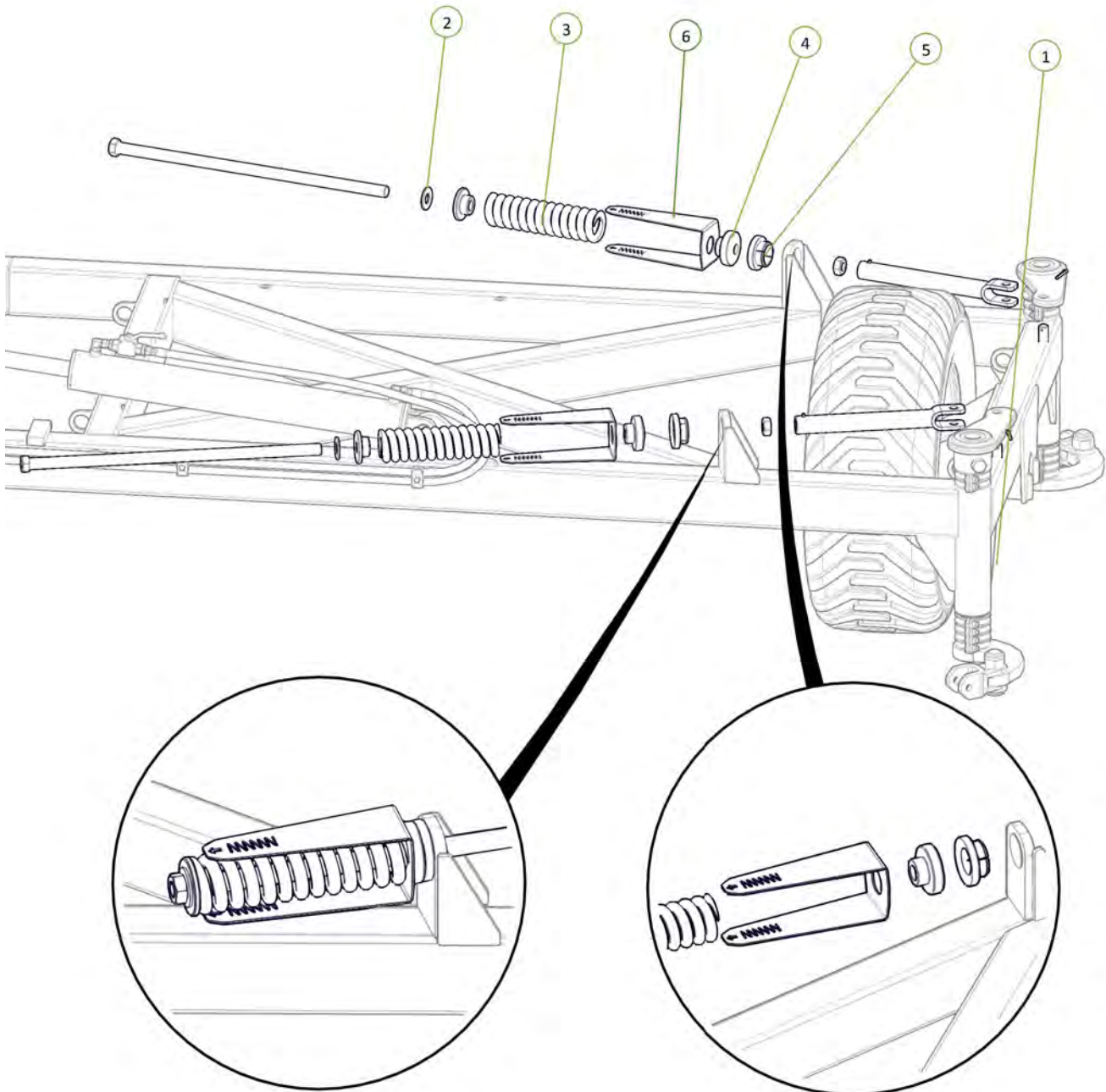

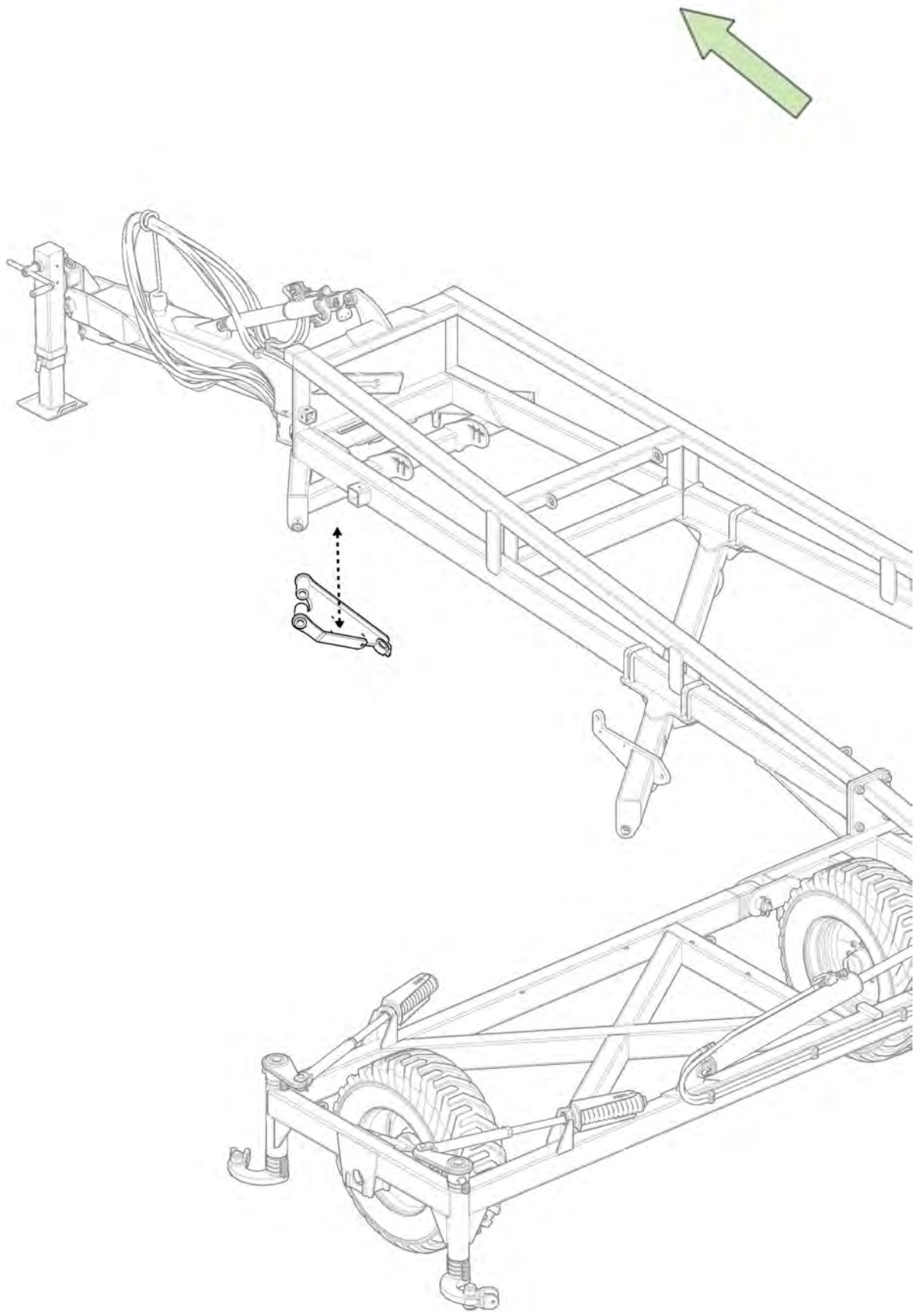

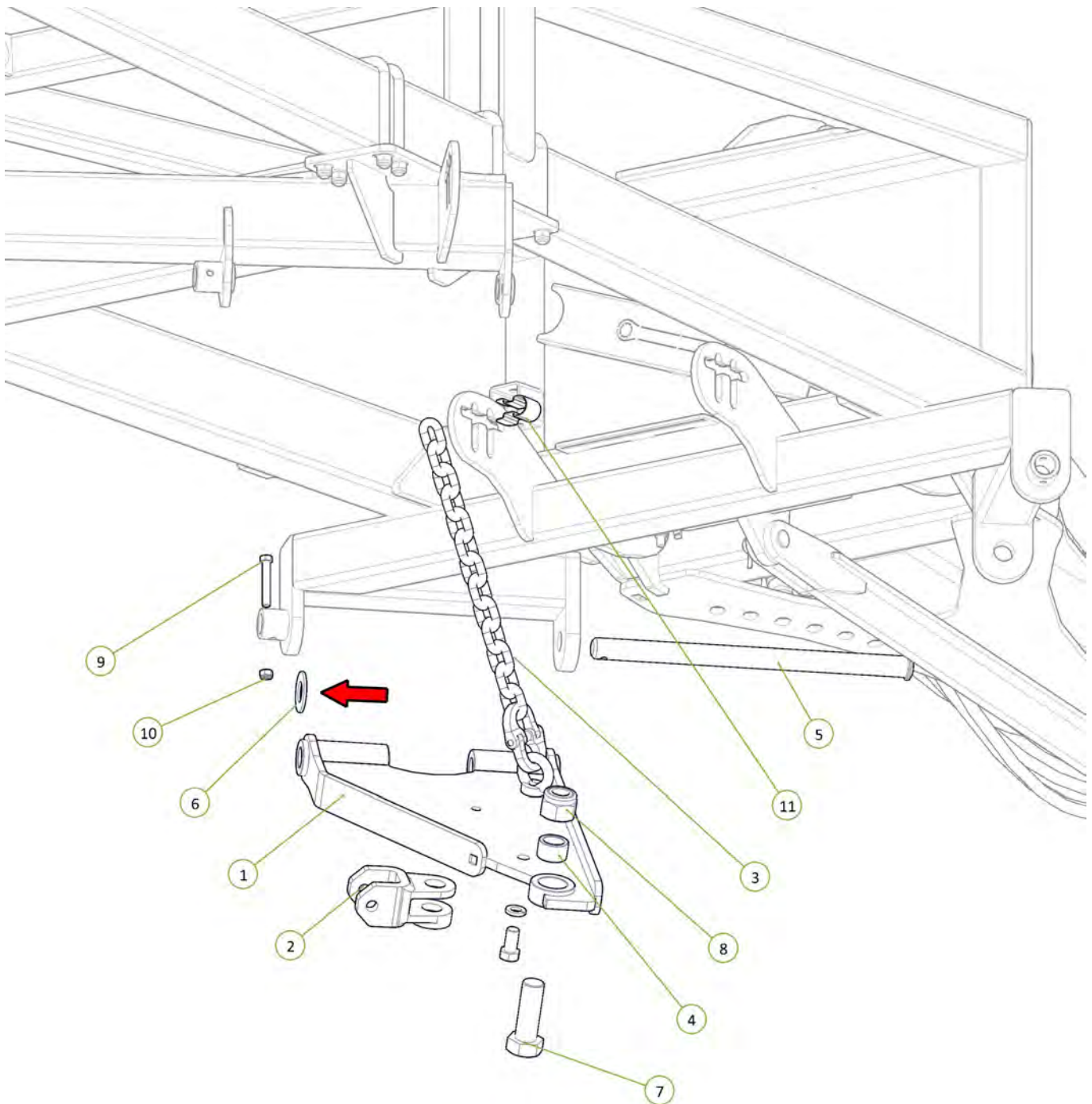

Item No.	Description	Number	Qty
1	Standard Chain Mount Plate	0810-20	1
2	Forged Clevis 21mm Bolt Hole	0801-FC21	1
3	Height Adjusting Chain Assembly 13 Link	0801-20MCA	1
4	Stainless Steel Wear Bush	1501-365033-SS	1
5	Chain Mount Pivot Pin	0801-10-51	1
6	Washer High Tensile 1 3/8"	0232-HT13-8	1
7	M36 x 105 grade 8.8 zp Bolt	0211-36105	1
8	Nyloc Nut M36	0221-NYL36	1
9	M12 x 80 Class 8.8 ZP Bolt	0211-1280	1
10	Nyloc Nut M12	0221-NYL12	1
11	Height Adjuster Retaining Clip	0801-KE014	1



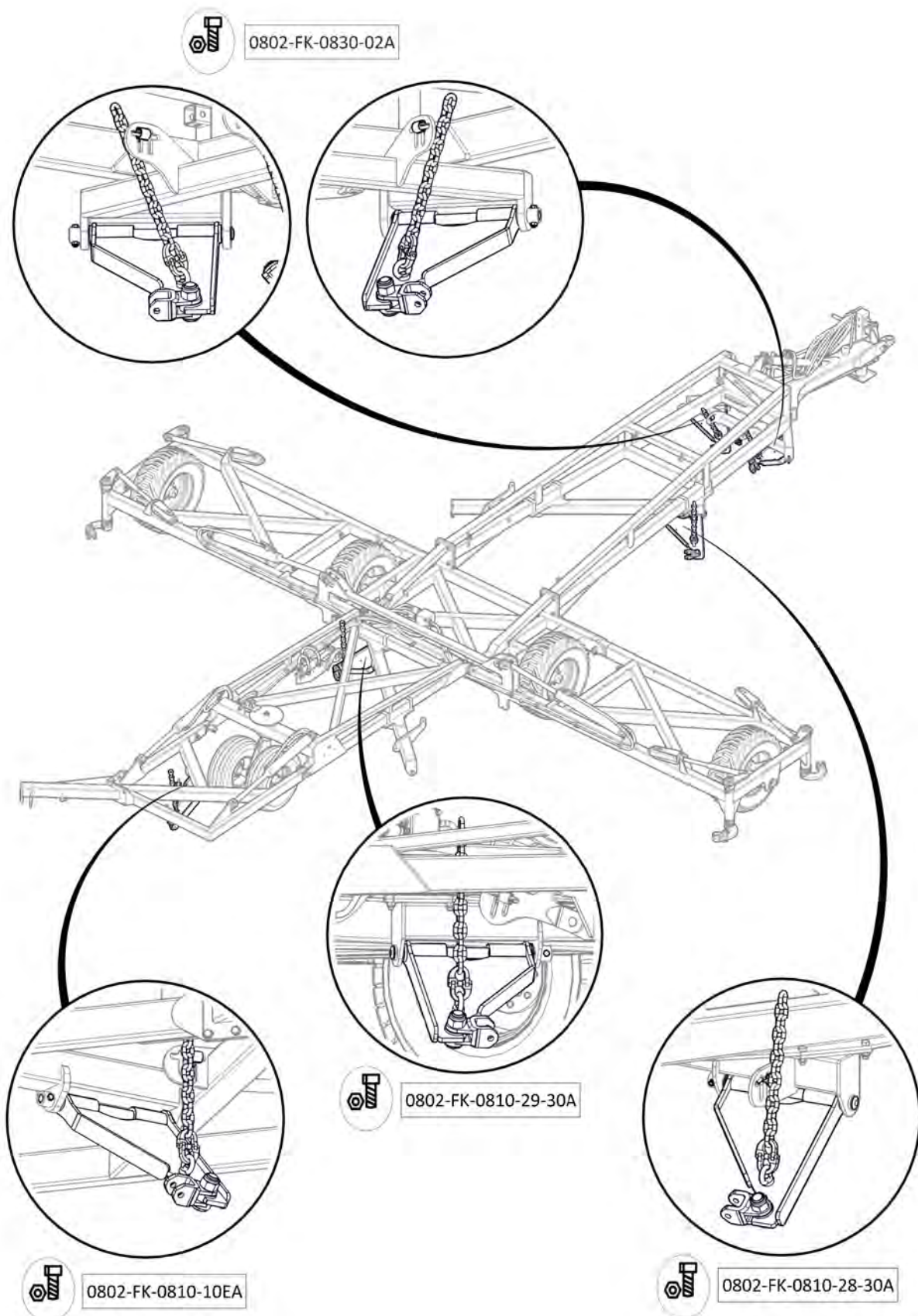

Item No.	Description	Number	Qty
1	Extended Chain Mount Plate	0810-69	1
2	Forged Clevis 21mm Bolt Hole	0801-FC21	1
3	Height Adjusting Chain Assembly 13 Link	0801-20MCA	1
4	Stainless Steel Wear Bush	1501-365033-SS	1
5	Chain Mount Pivot Pin	0801-10-51	1
6	Washer High Tensile 1 3/8"	0232-HT13-8	1
7	Height Adjustor Retaining Clip	0801-KE014	1
8	M36 x 105 grade 8.8 zp Bolt	0211-36105	1
9	Nyloc Nut M36	0221-NYL36	1
10	M12 x 80 Class 8.8 ZP Bolt	0211-1280	1
11	Nyloc Nut M12	0221-NYL12	1

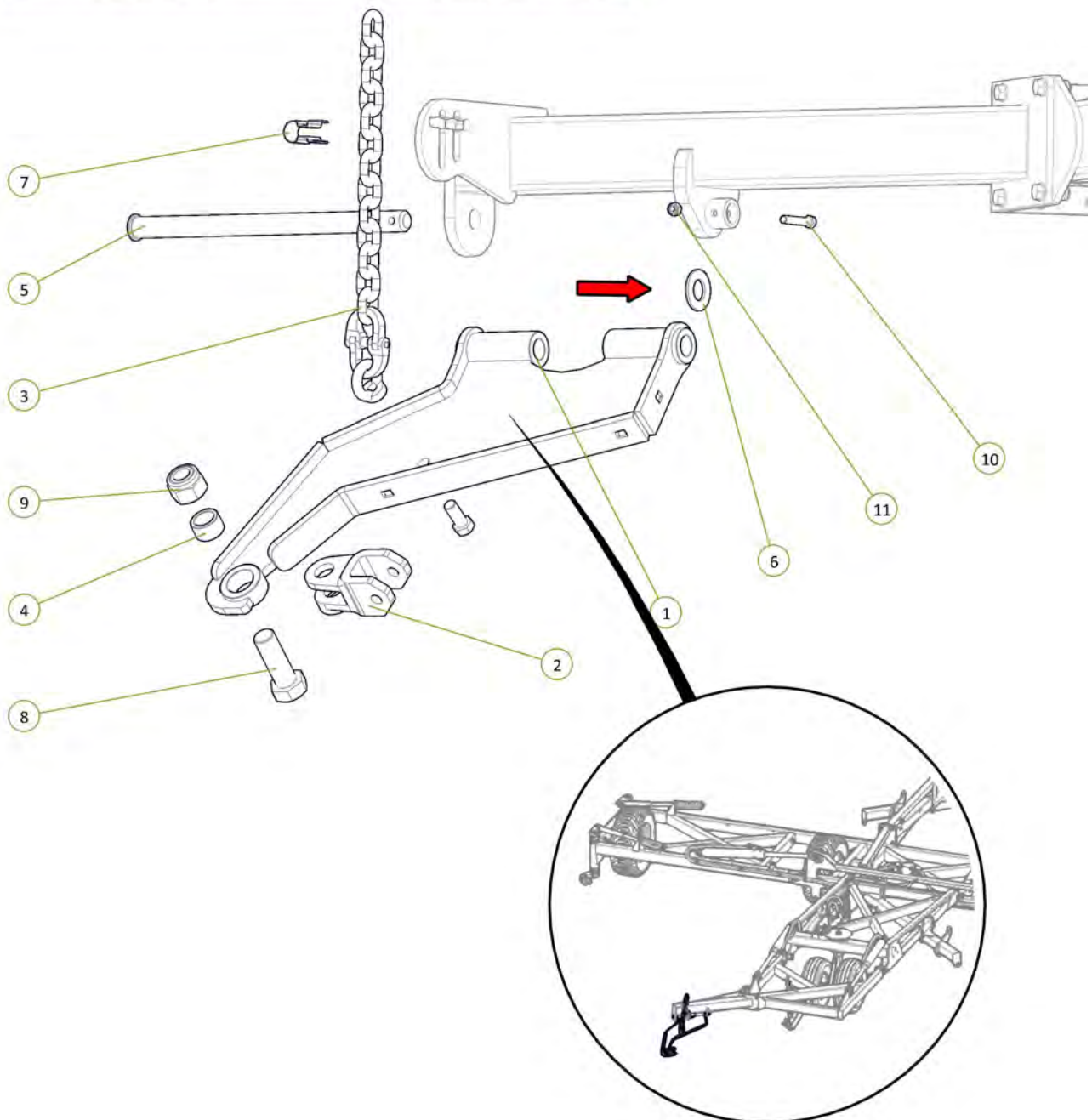
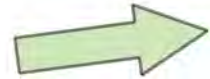

Item No.	Description	Number	Qty
1	Tension Box	0810-57	1
2	Module Tension Rod Assembly	0810-105A	1
3	20mm Compression Spring	0801-XK9261S	1
4	Rigid Spring Locator	0801-10-S2L	1
5	Washer High Tensile 1 1/4"	0232-HT11-4	1
6	Height Adjusting Chain Assembly 13 Link	0801-20MCA	1

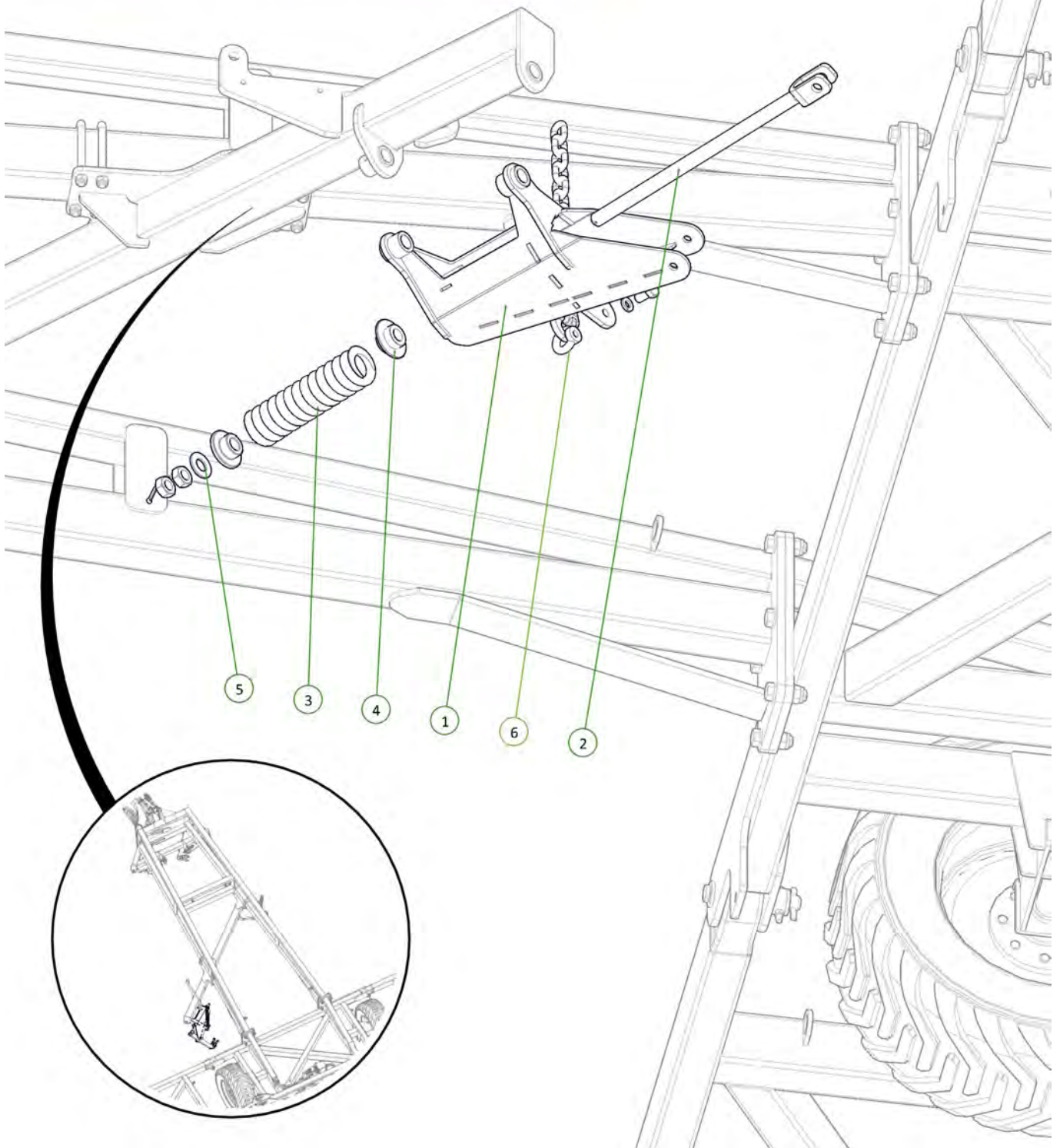

Item No.	Description	Number	Qty
1	Module Tension Arm No Clevis	0810-104F	1
2	35 ID x 50mm DU Bush	0113-MB3550DU	2
3	Module Pivot Arm Bush	0801-10-110	1
4	M20 x 160 Class 8.8 ZP Bolt	0211-20160	1
5	Forged Clevis 21mm Bolt Hole	0801-FC21	1
6	M36 x 105 grade 8.8 zp Bolt	0211-36105	1
7	Stainless Steel Wear Bush	1501-365033-SS	1
8	Washer Flat M24	0231-F24	1
9	Washer Flat M20	0231-F20	2
10	Nyloc Nut M36	0221-NYL36	1
11	Nyloc Nut M20	0221-NYL20	1

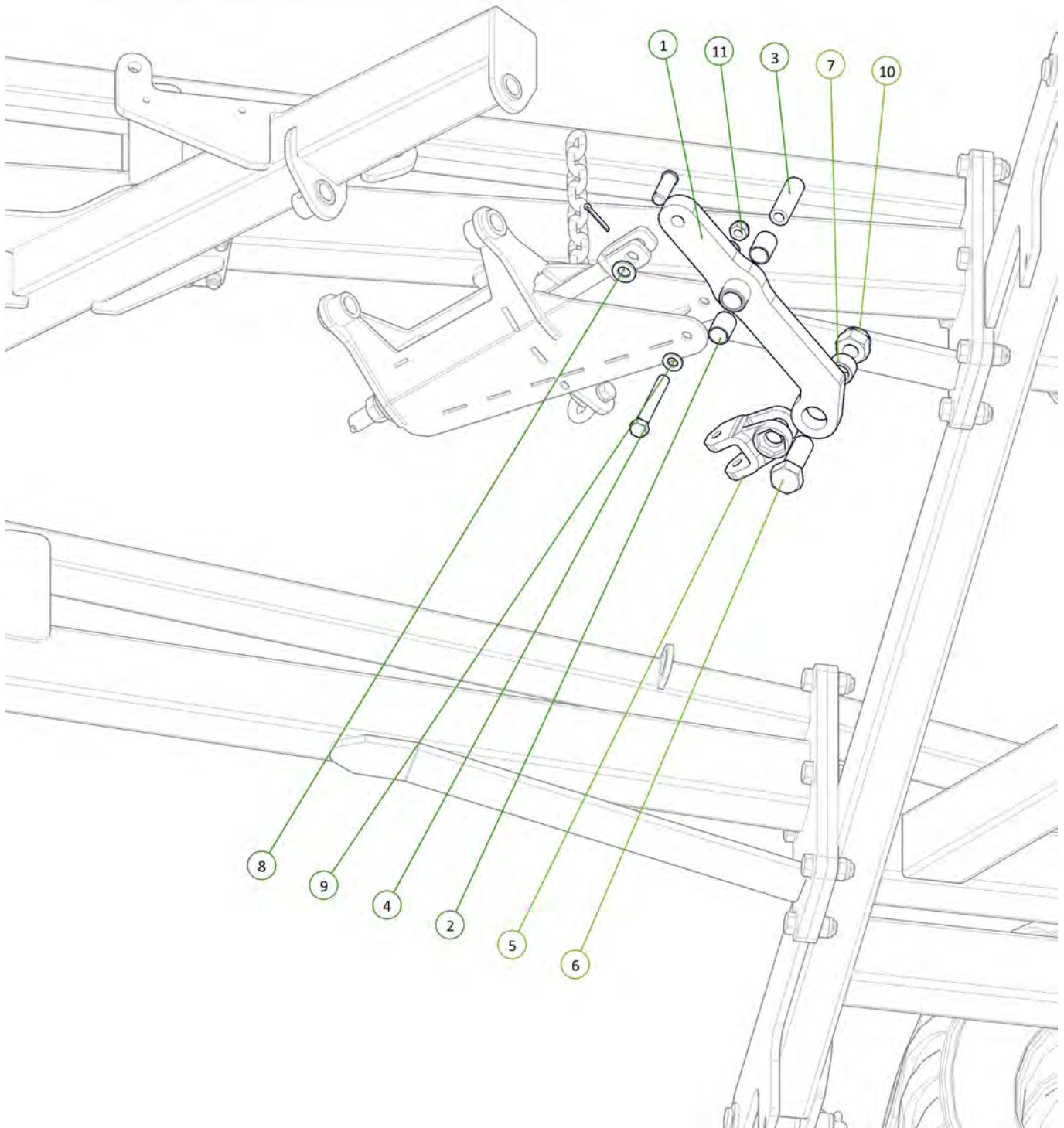

Item No.	Description	Number	Qty
1	Chain Mount Pivot Pin	0801-10-51	1
2	Washer High Tensile 1 3/8"	0232-HT13-8	1
3	M12 x 80 Class 8.8 ZP Bolt	0211-1280	1
4	Nyloc Nut M12	0221-NYL12	1

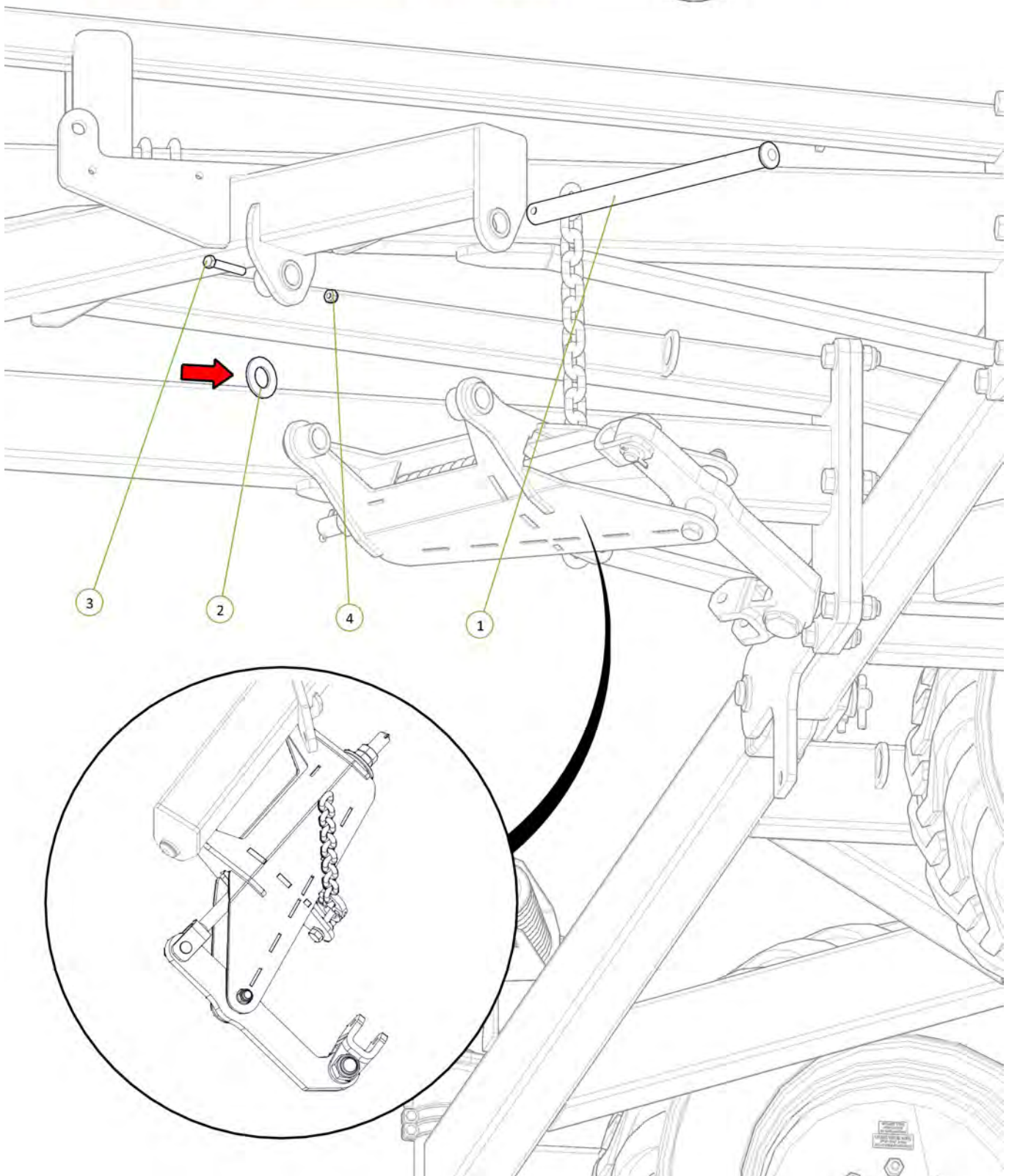
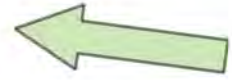

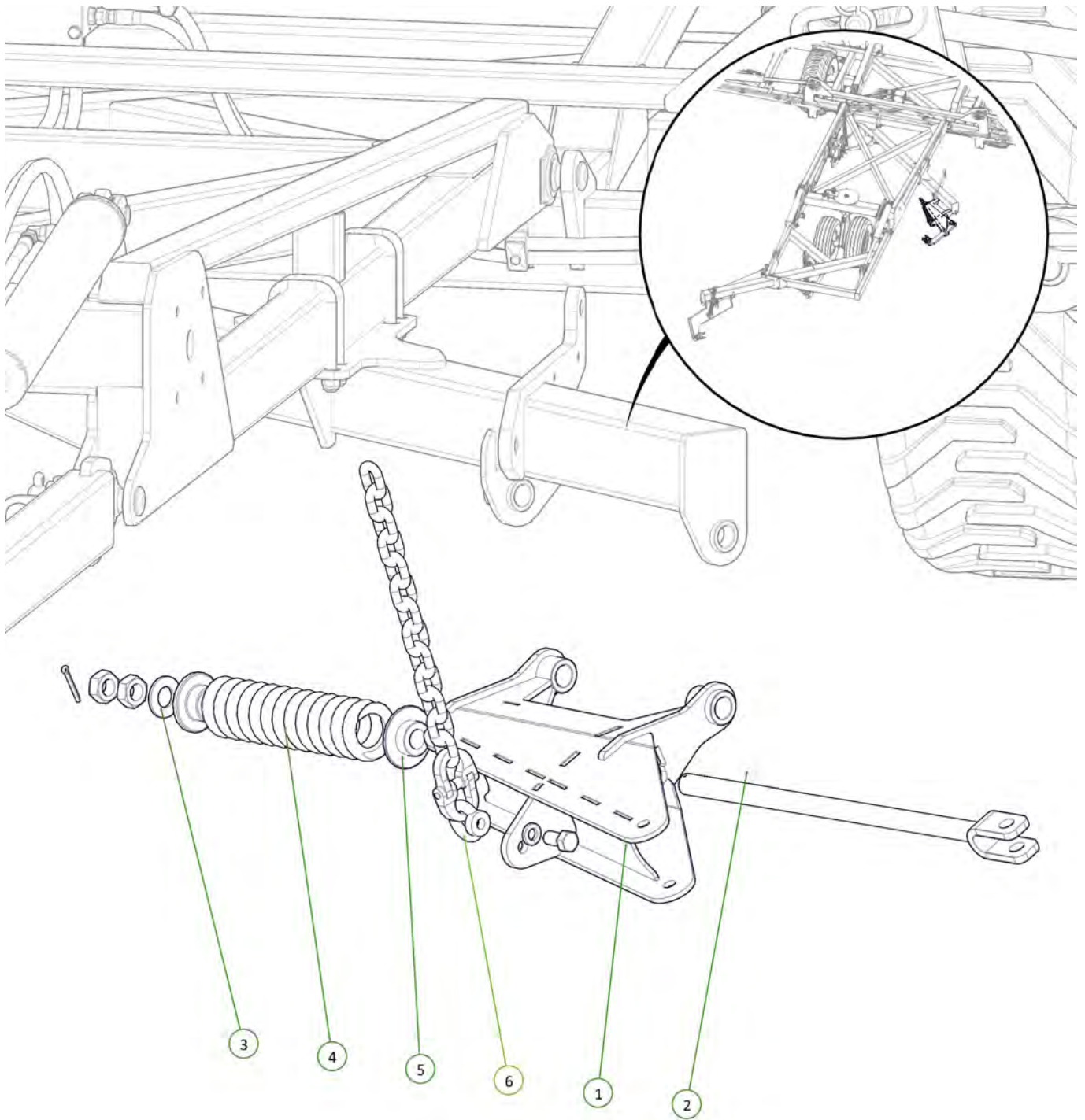

Item No.	Description	Number	Qty
1	Tension Box	0810-57	1
2	Module Tension Rod Assembly	0810-105A	1
3	Washer High Tensile 1 1/4"	0232-HT11-4	1
4	20mm Compression Spring	0801-XK9261S	1
5	Rigid Spring Locator	0801-10-S2L	1
6	Height Adjusting Chain Assembly 13 Link	0801-20MCA	1



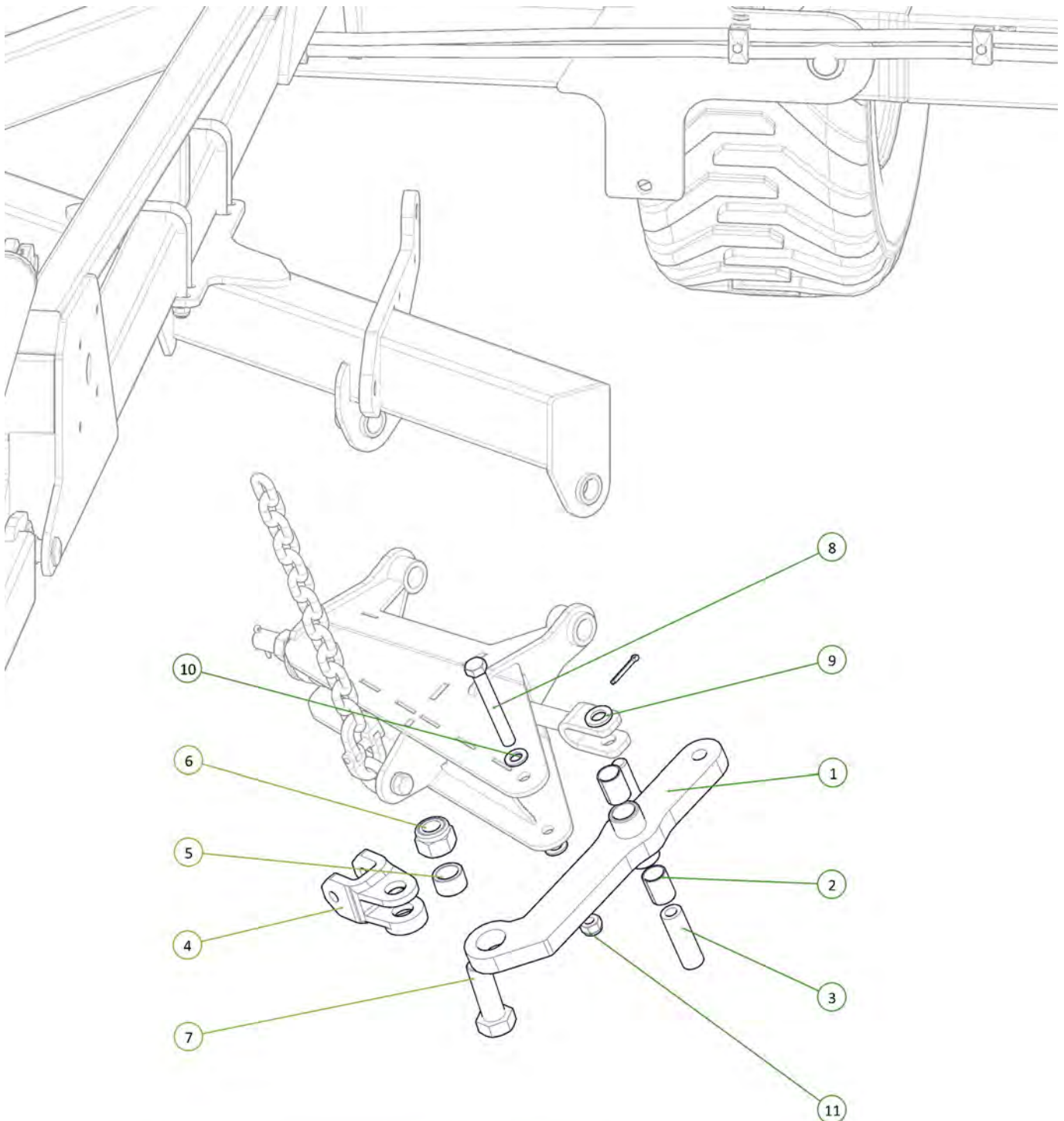

Item No.	Description	Number	Qty
1	Module Tension Arm No Clevis	0810-104F	1
2	35 ID x 50mm DU Bush	0113-MB3550DU	2
3	Module Pivot Arm Bush	0801-10-110	1
4	Forged Clevis 21mm Bolt Hole	0801-FC21	1
5	Stainless Steel Wear Bush	1501-365033-SS	1
6	Nyloc Nut M36	0221-NYL36	1
7	M36 x 105 grade 8.8 zp Bolt	0211-36105	1
8	M20 x 160 Class 8.8 ZP Bolt	0211-20160	1
9	Washer Flat M24	0232-F24	1
10	Washer Flat M20	0231-F20	2
11	Nyloc Nut M20	0221-NYL20	1



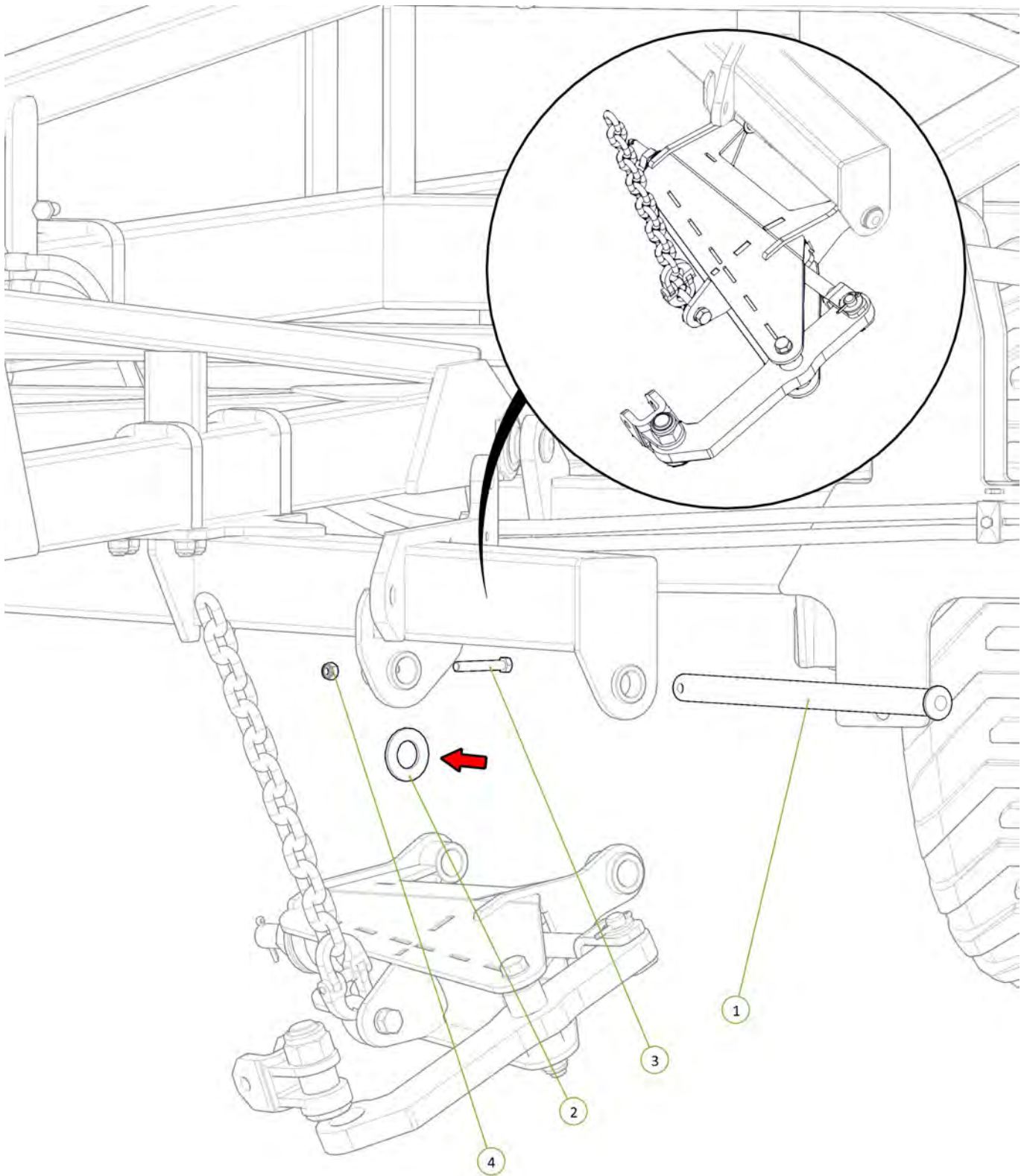

Item No.	Description	Number	Qty
1	Chain Mount Pivot Pin	0801-10-51	1
2	Washer High Tensile 1 3/8"	0232-HT13-8	1
3	M12 x 80 Class 8.8 ZP Bolt	0211-1280	1
4	Nyloc Nut M12	0221-NYL12	1



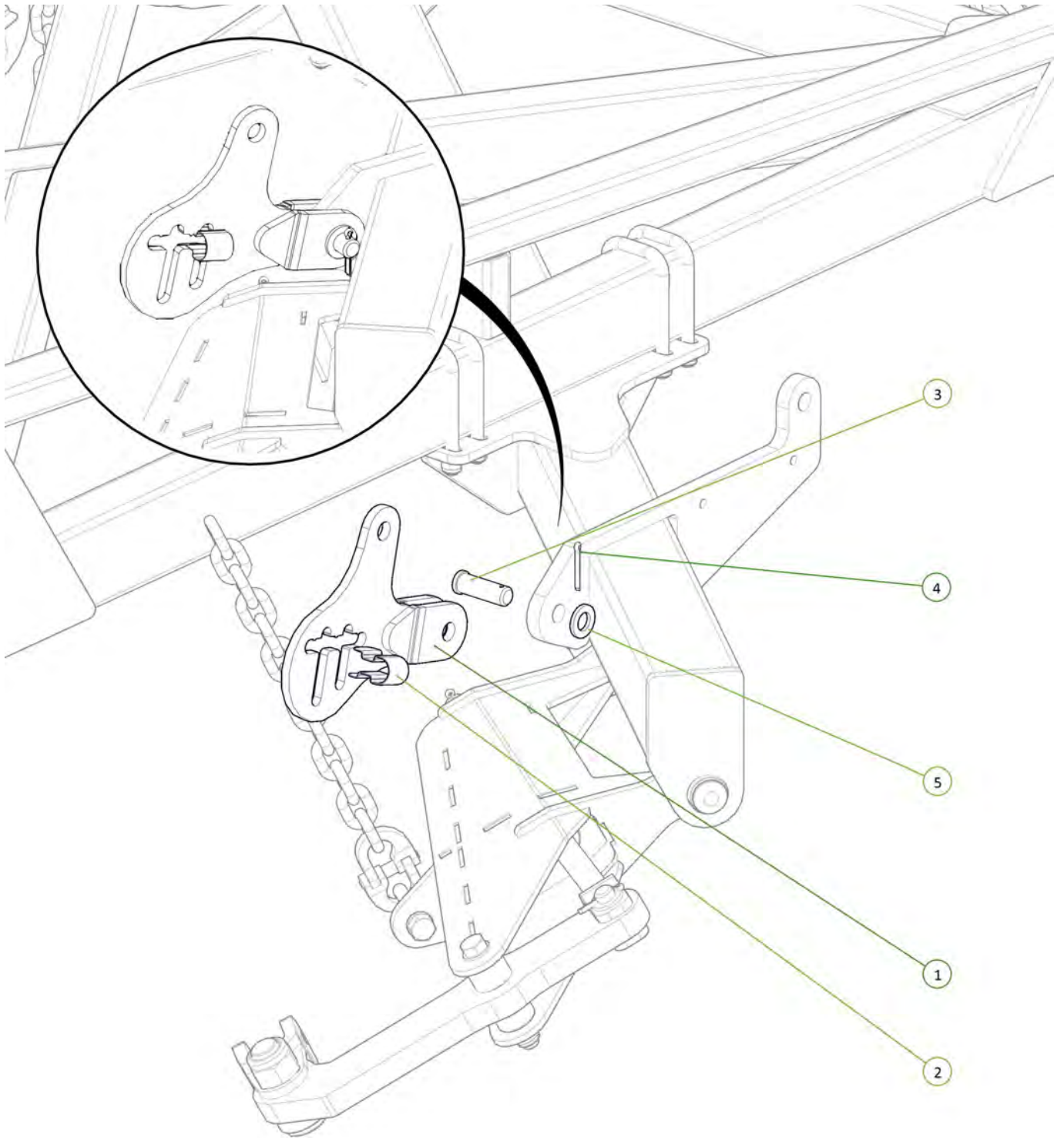

Item No.	Description	Number	Qty
1	Reduced Lift Arm	0810-84	1
2	Height Adjuster Retaining Clip	0801-KE014	1
3	Clevis Pin 25mm x 75mm	0801-KE0307-1	1
4	Cotter Pin M6 x 50mm	0261-PINC650	1
5	Washer Flat M24	0231-F24	1



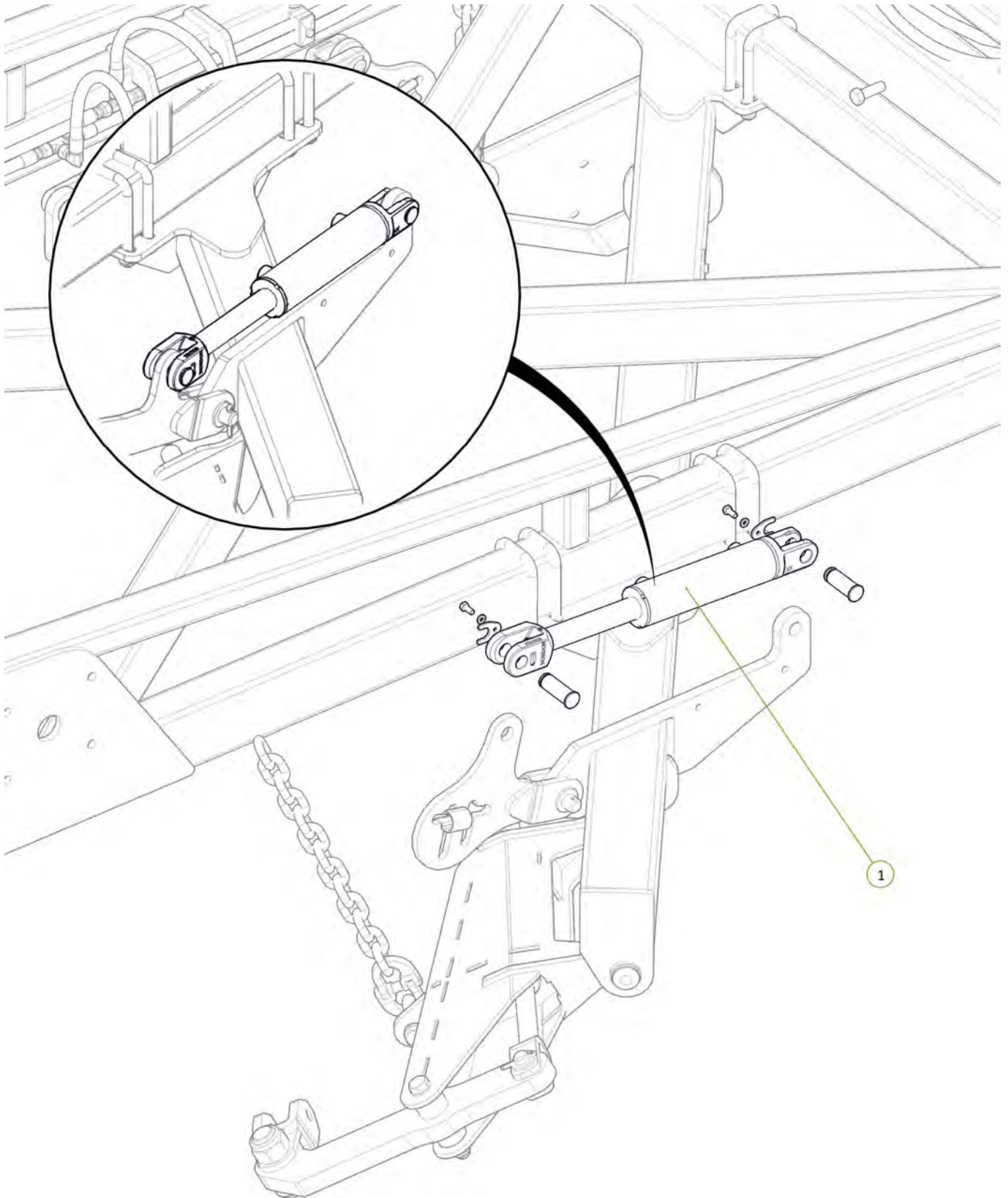

Item No.	Description	Number	Qty
1	2.5" Bore x 6" Stroke 1.5" Rod Side Port Cylinder	0311-256SP	1



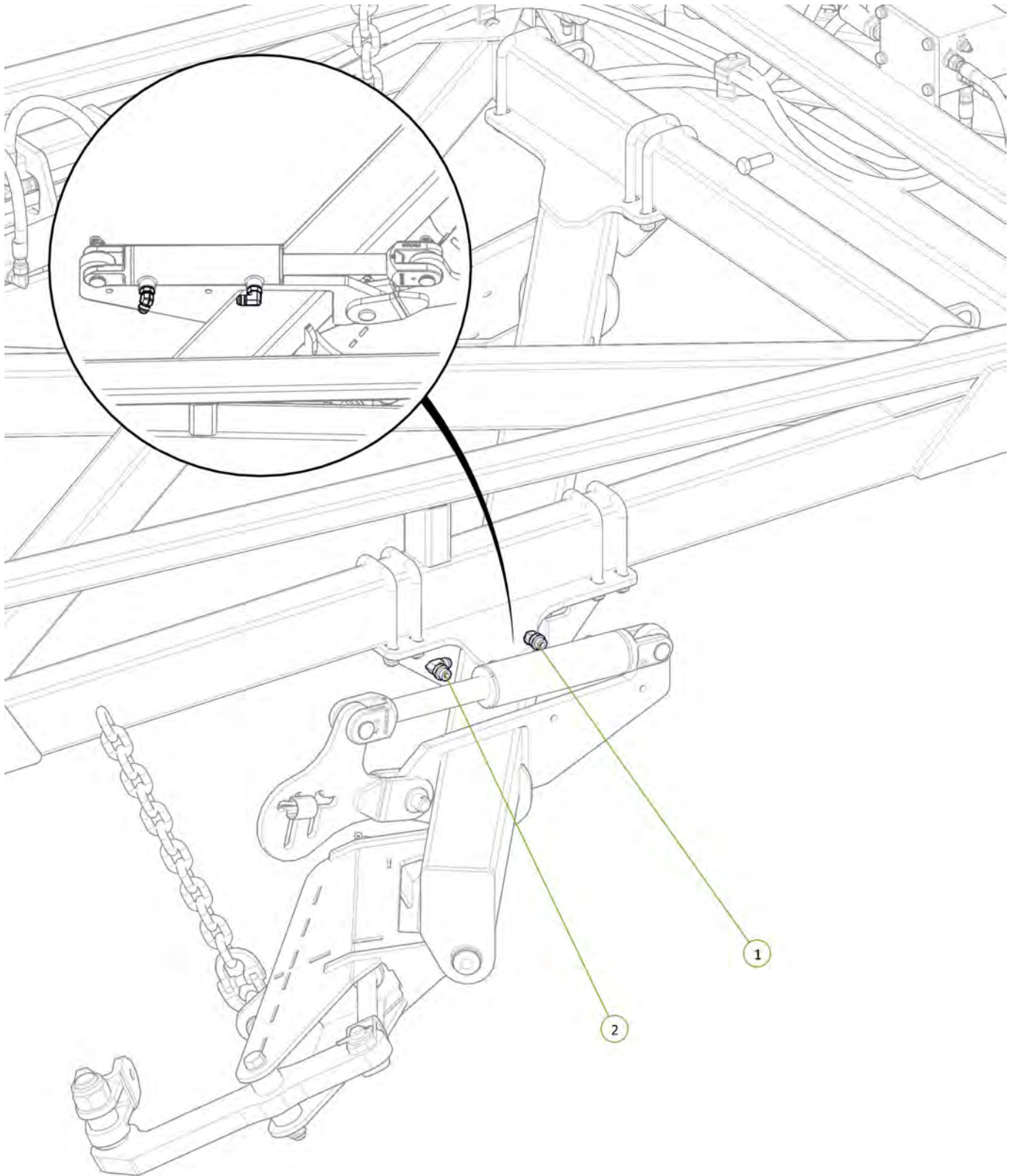

Item No.	Description	Number	Qty
1	3/4" JIC Male 3/4" UN O Ring Male 45° Elbow	0323-S88-1212	1
2	3/4" JIC Male 3/4" UN O Ring Male 90° Elbow	0323-S91-1212	1



Item No.	Description	Number	Qty
1	Valve RME Port to Right Rear Module Rear Port	PH30S-15	1
2	Valve RMR Port to Right Rear Module Rod Port	PH30S-16	1

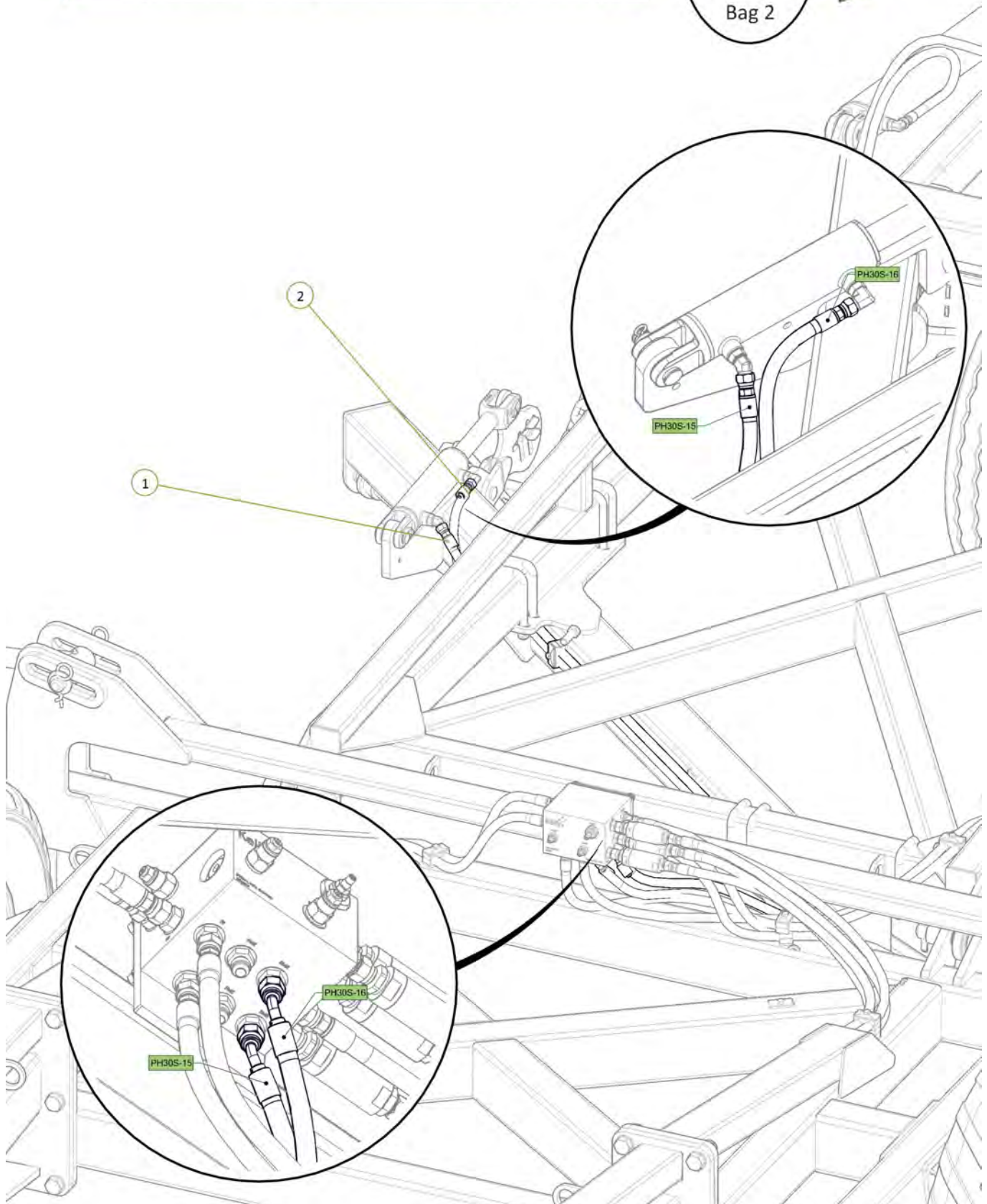

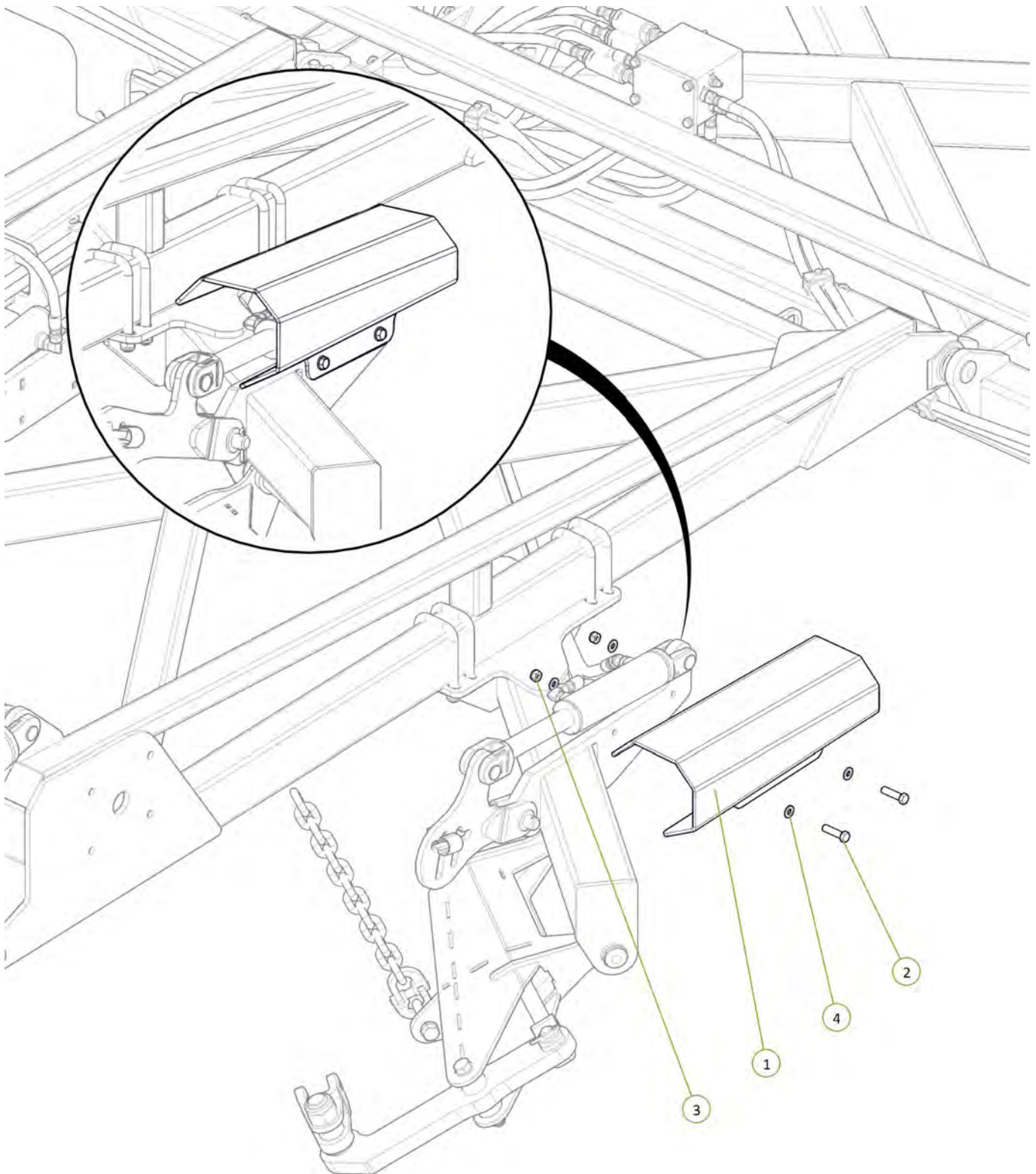

Item No.	Description	Number	Qty
1	Module Cylinder Guard	0800-167.3	1
2	M12 x 50 grade 8.8 ZP Bolt	0211-1250	2
3	Nyloc Nut M12	0221-NYL12	2
4	Washer Flat M12	0231-F12	4



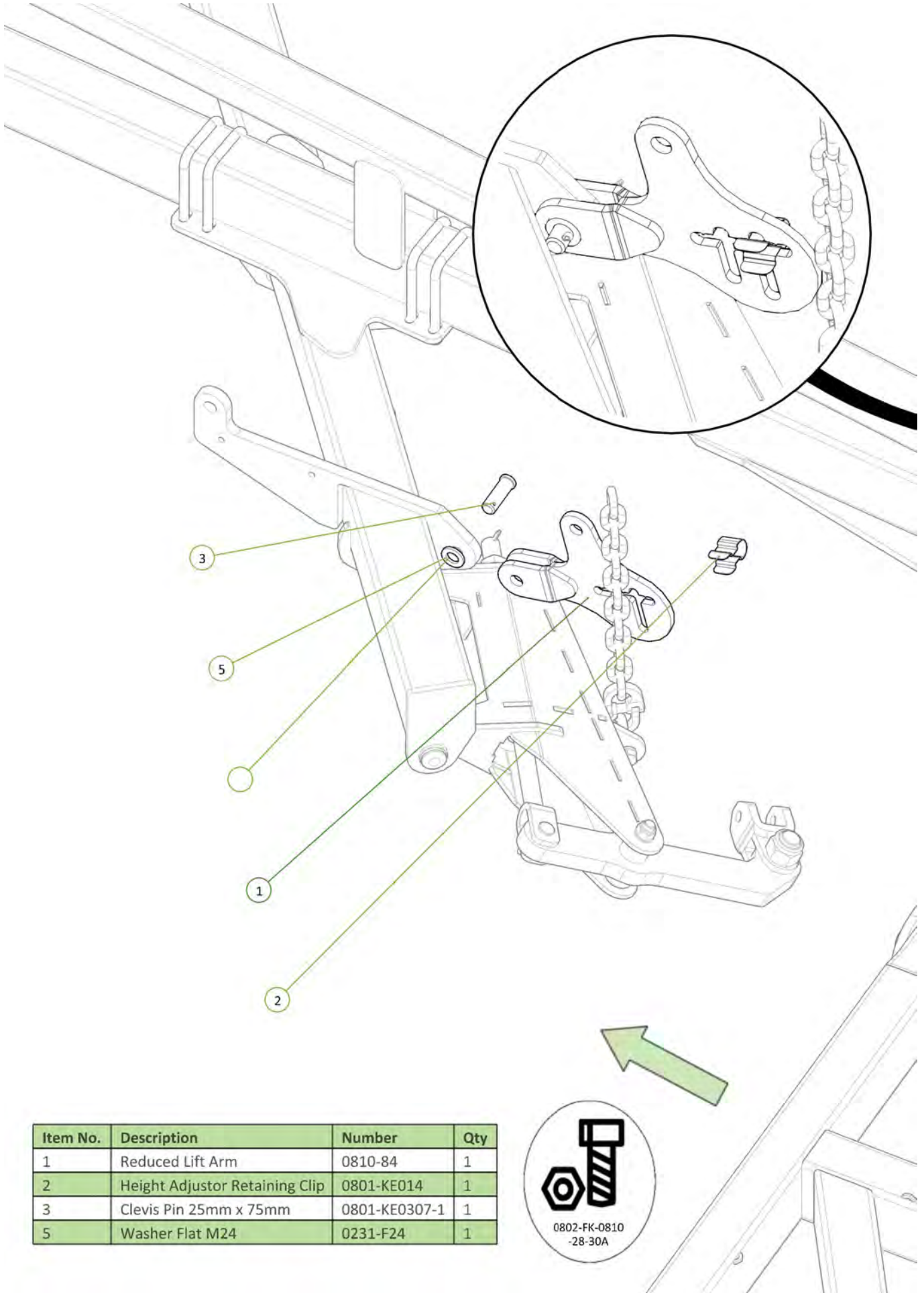

Item No.	Description	Number	Qty
1	Reduced Lift Arm	0810-84	1
2	Height Adjustor Retaining Clip	0801-KE014	1
3	Clevis Pin 25mm x 75mm	0801-KE0307-1	1
5	Washer Flat M24	0231-F24	1



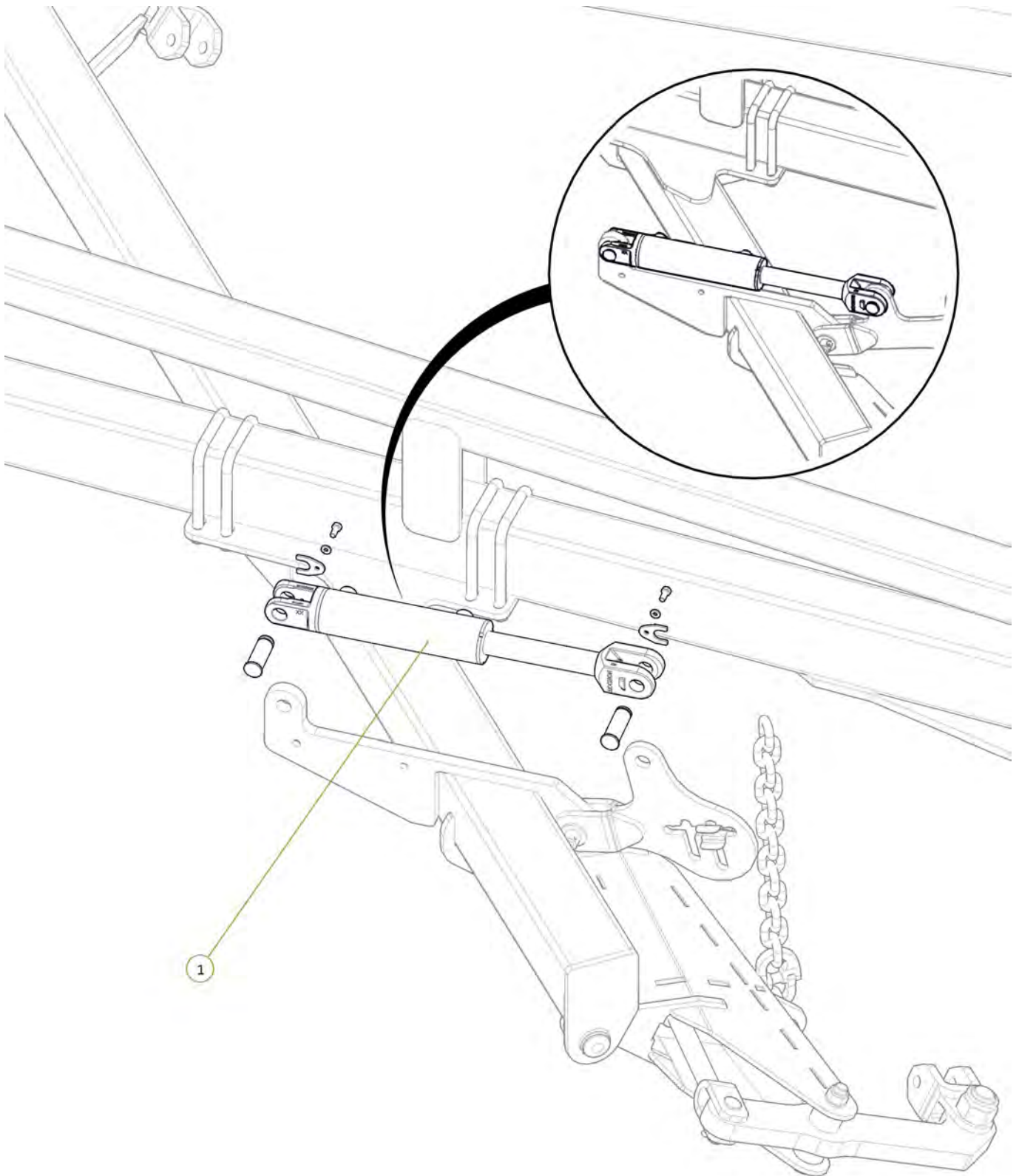

Item No.	Description	Number	Qty
1	2.5" Bore x 6" Stroke 1.5" Rod Side Port Cylinder	0311-256SP	1



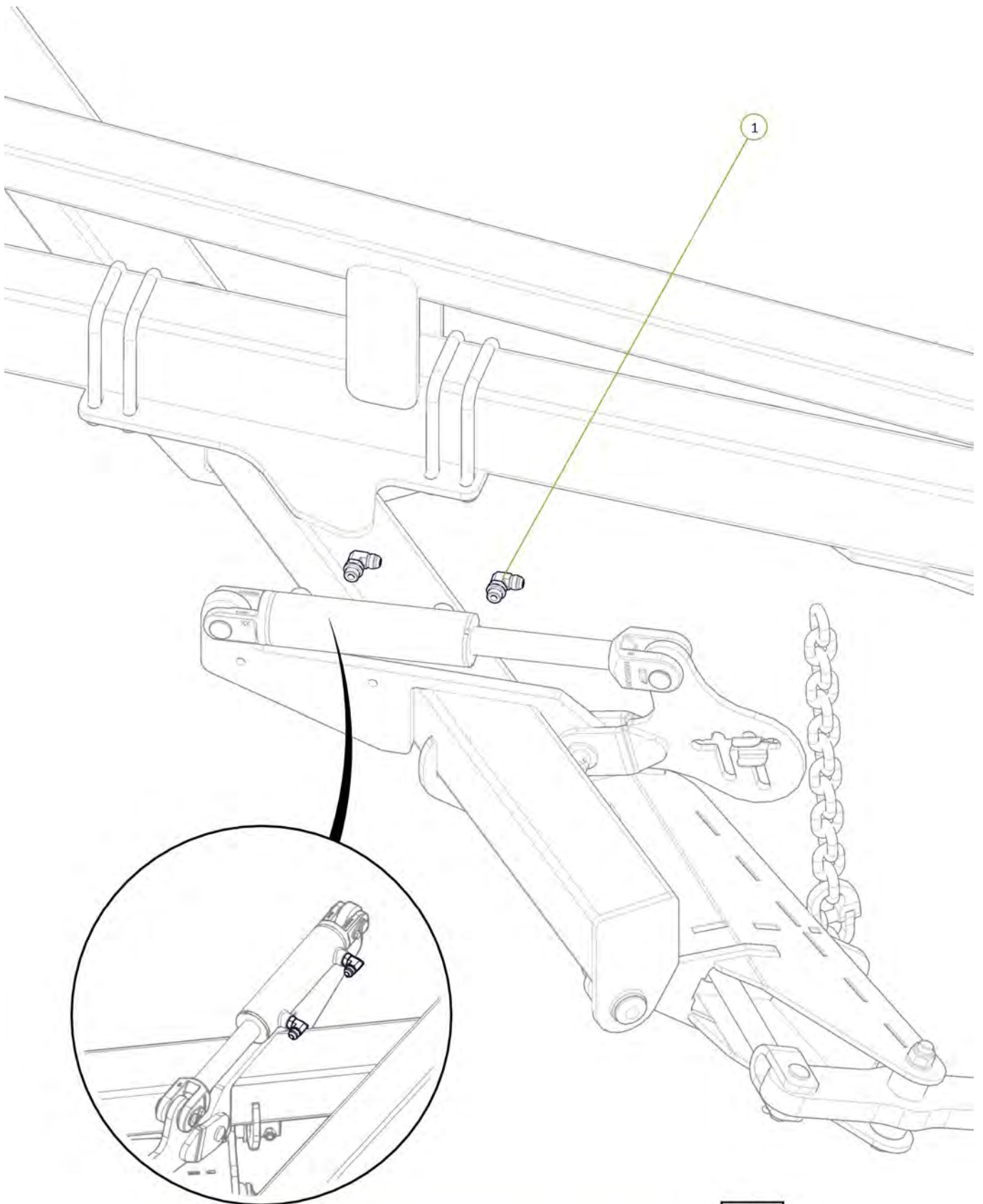

Item No.	Description	Number	Qty
1	3/4" JIC Male 3/4" UN O Ring Male 90° Elbow	0323-S91-1212	2



Item No.	Description	Number	Qty
1	Front Module EXT Port to Valve FME Port	PH30S-03	1
2	Front Module Rod Port to Valve FMR Port	PH30S-04	1

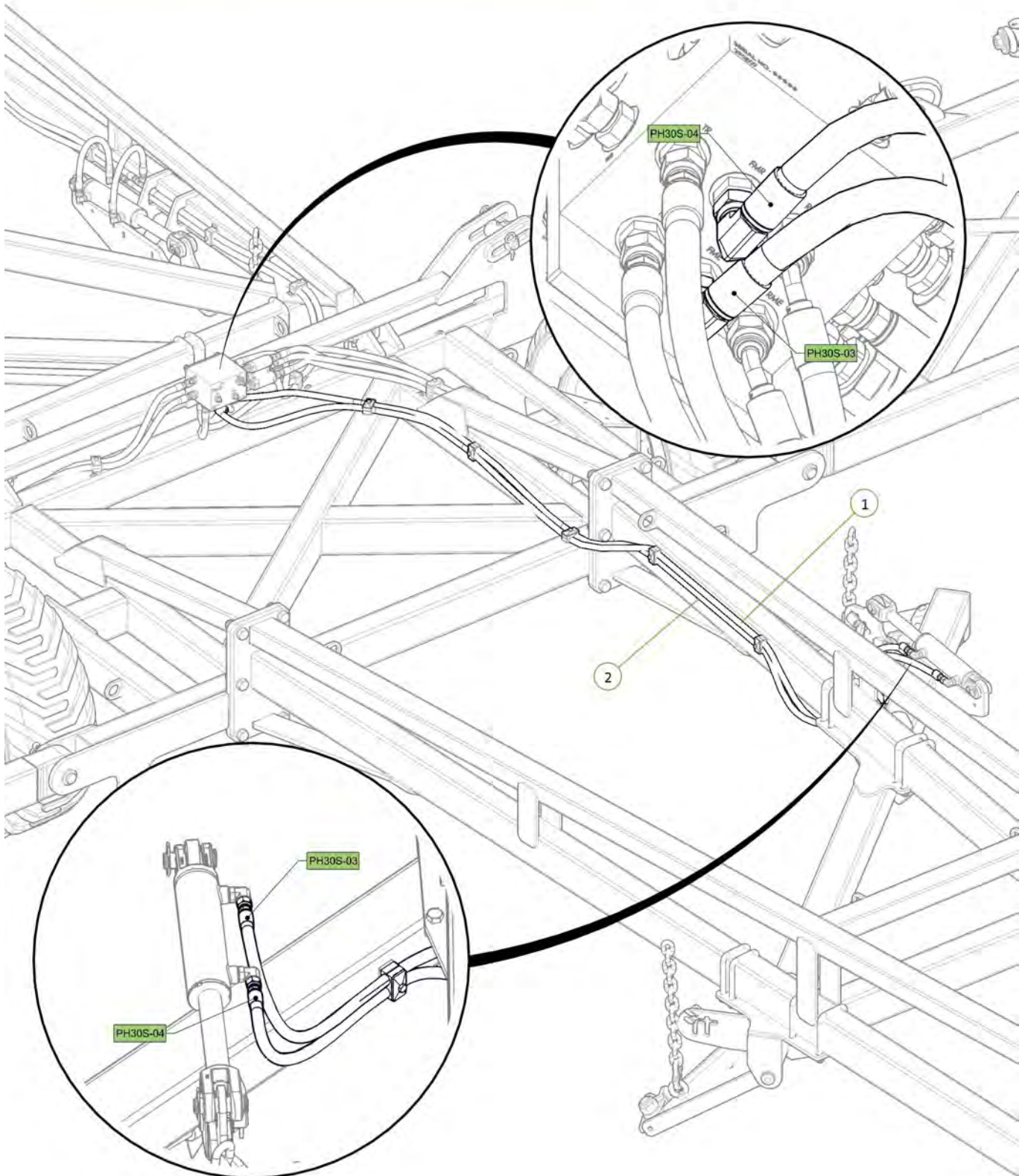
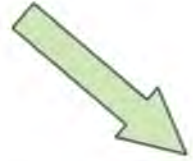

Item No.	Description	Number	Qty
1	30' Chain Carrier Beam	0810-17-30	1
2	Chain Carrier Mount Plate	0800-139.1	2
3	U-Bolt M16 x 114 Deep x 106 Wide	0271-16112104	4
4	U-Bolt M16 x 162 Deep x 129 Wide	0271-16160127	4
5	Washer Flat M16	0231-F16	16
6	Nyloc Nut M16	0221-NYL16	16

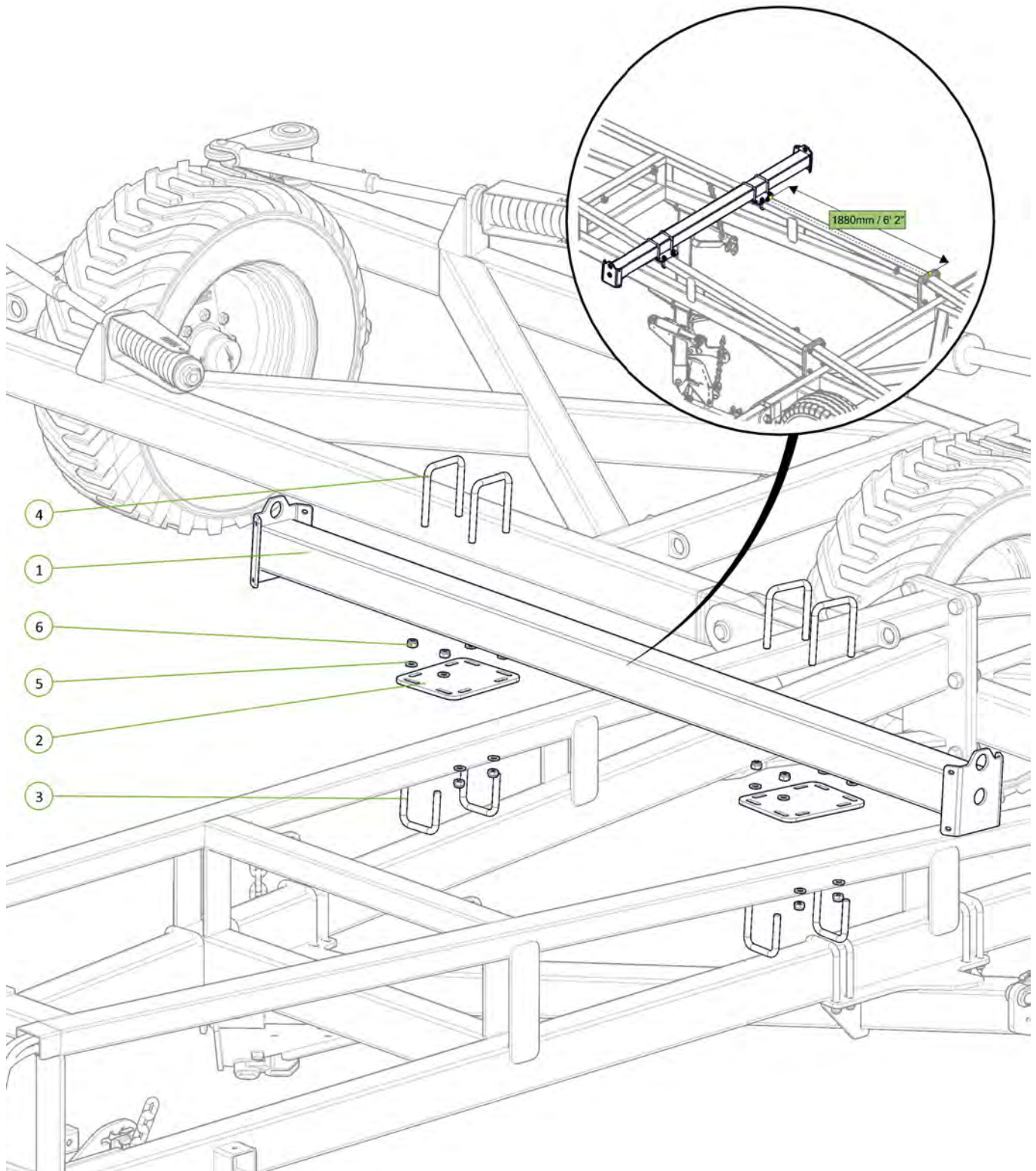

Item No.	Description	Number	Qty
1	Extended Chain Carrier Bolt on End	0810-17LE	2
2	M12 x 40 Coach Head Bolt	0215-CH1240	8
3	Nyloc Nut M12	0221-NYL12	8
4	Washer Flat M12	0231-F12	8

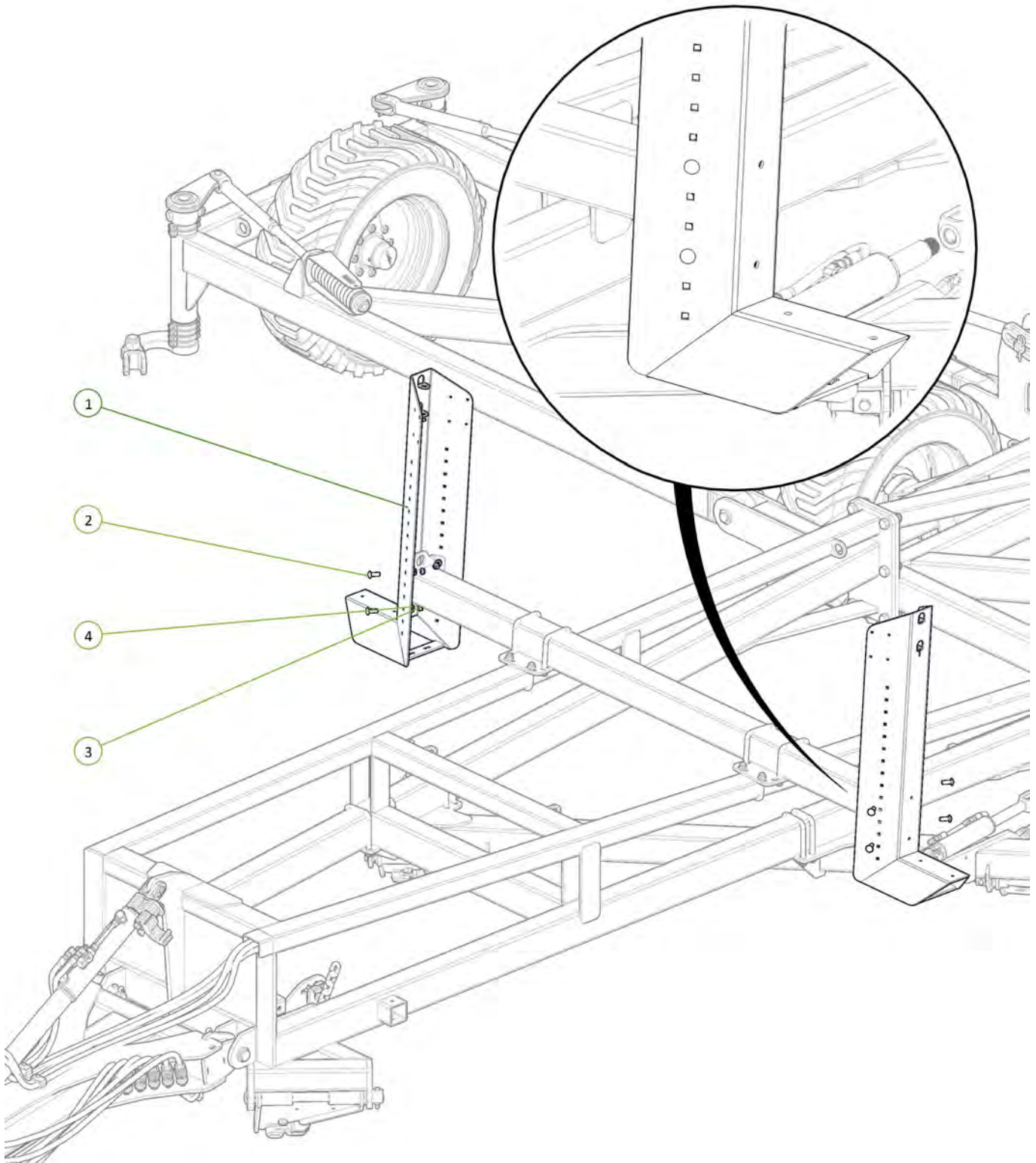
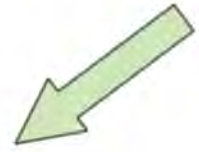

Item No.	Description	Number	Qty
1	30' & 40' Outrigger	0810-40	2
2	M16 x 55 grade 8.8 zp Bolt	0211-1655	8
3	Washer Flat M16	0231-F16	16
4	Nyloc Nut M16	0221-NYL16	8

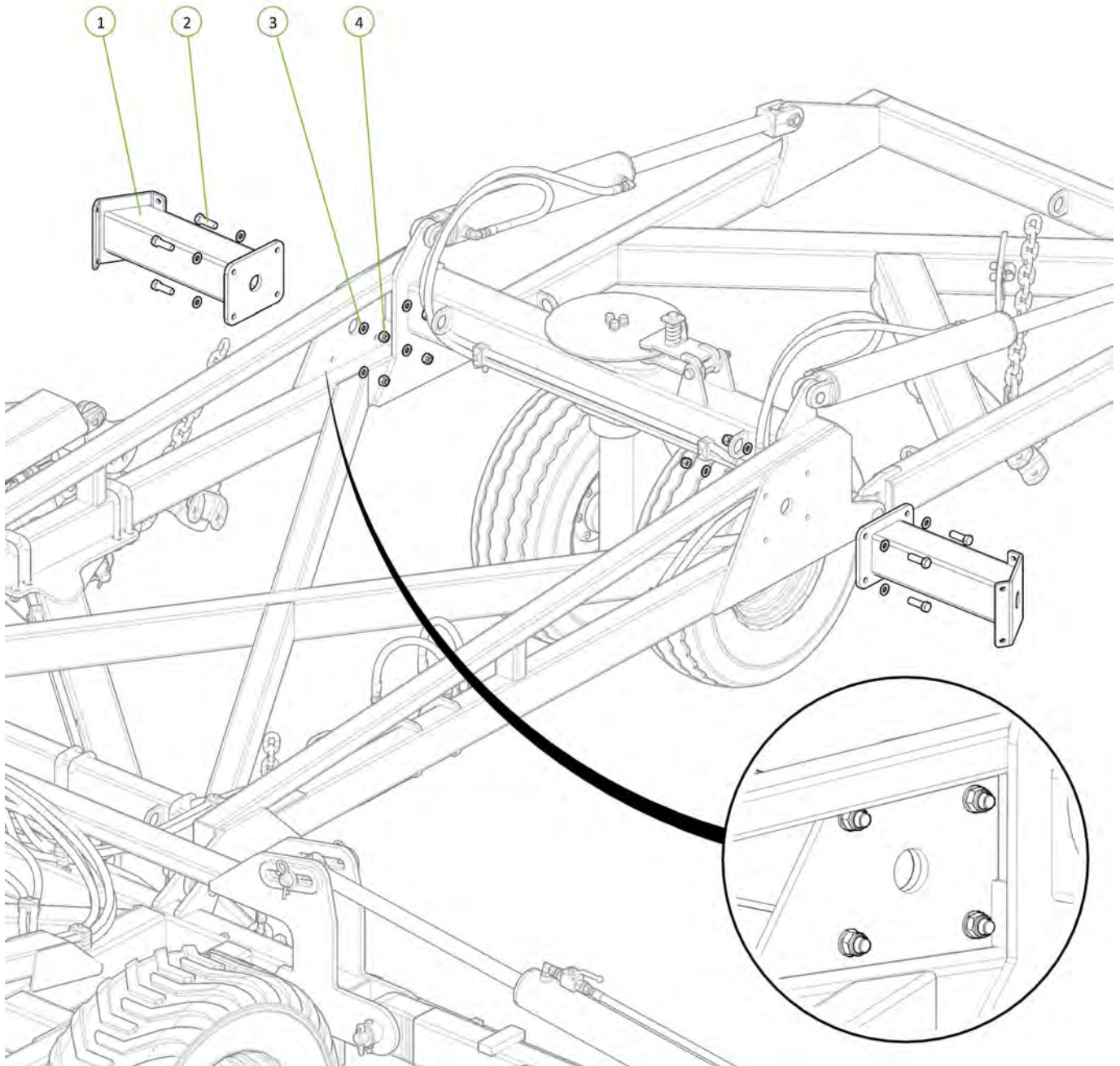

Item No.	Description	Number	Qty
1	Extended Chain Carrier Bolt on End	0810-17LE	2
2	M12 x 40 Coach Head Bolt	0215-CH1240	8
3	Nyloc Nut M12	0221-NYL12	8
4	Washer Flat M12	0231-F12	8

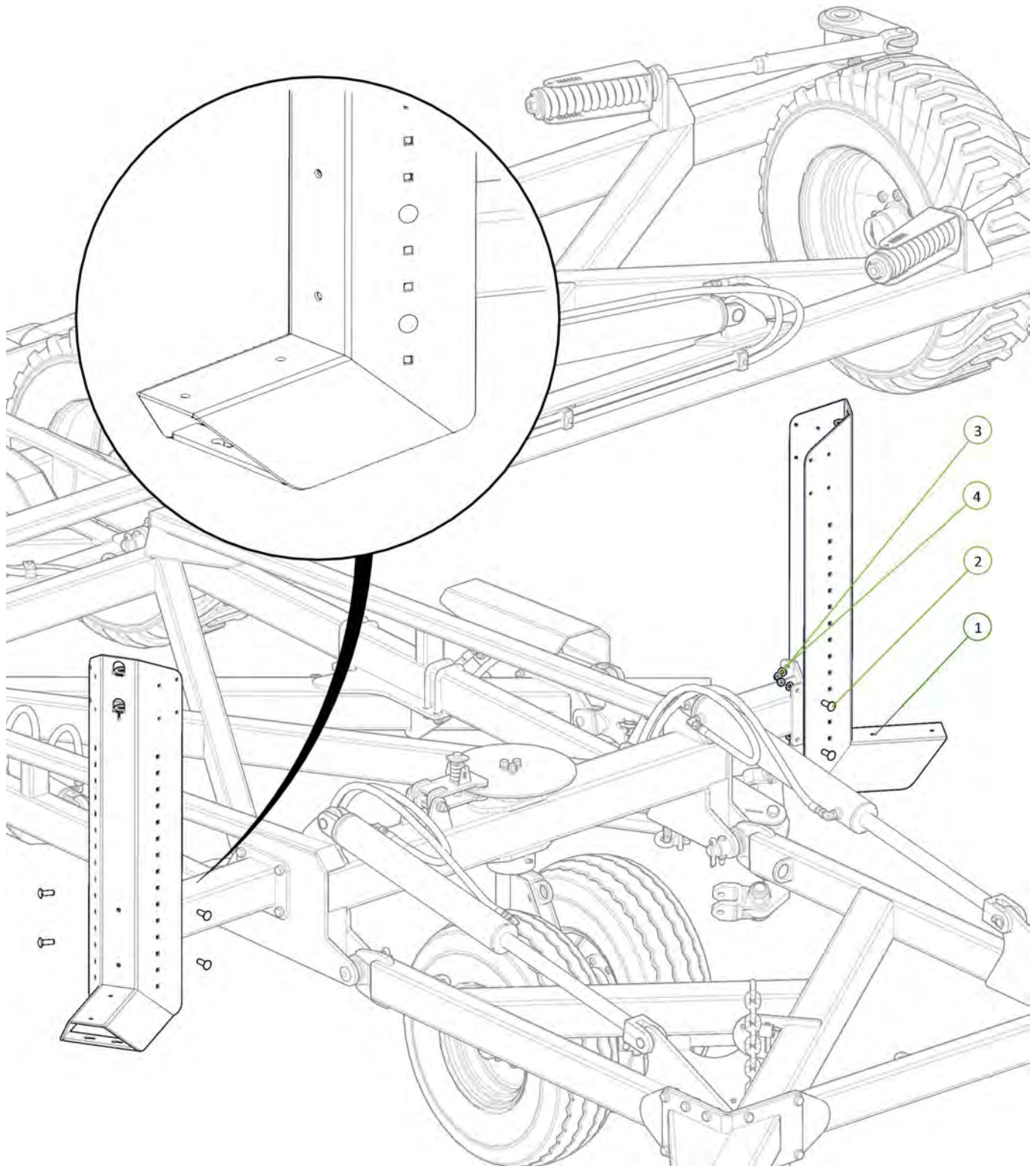

Item No.	Description	Number	Qty
1	30' Chain Retainer Plate	0800-360	2
2	M12 x 35 grade 8.8 ZP Bolt	0211-1235	8
3	Nyloc Nut M12	0221-NYL12	8
4	Washer Flat M12	0231-F12	16

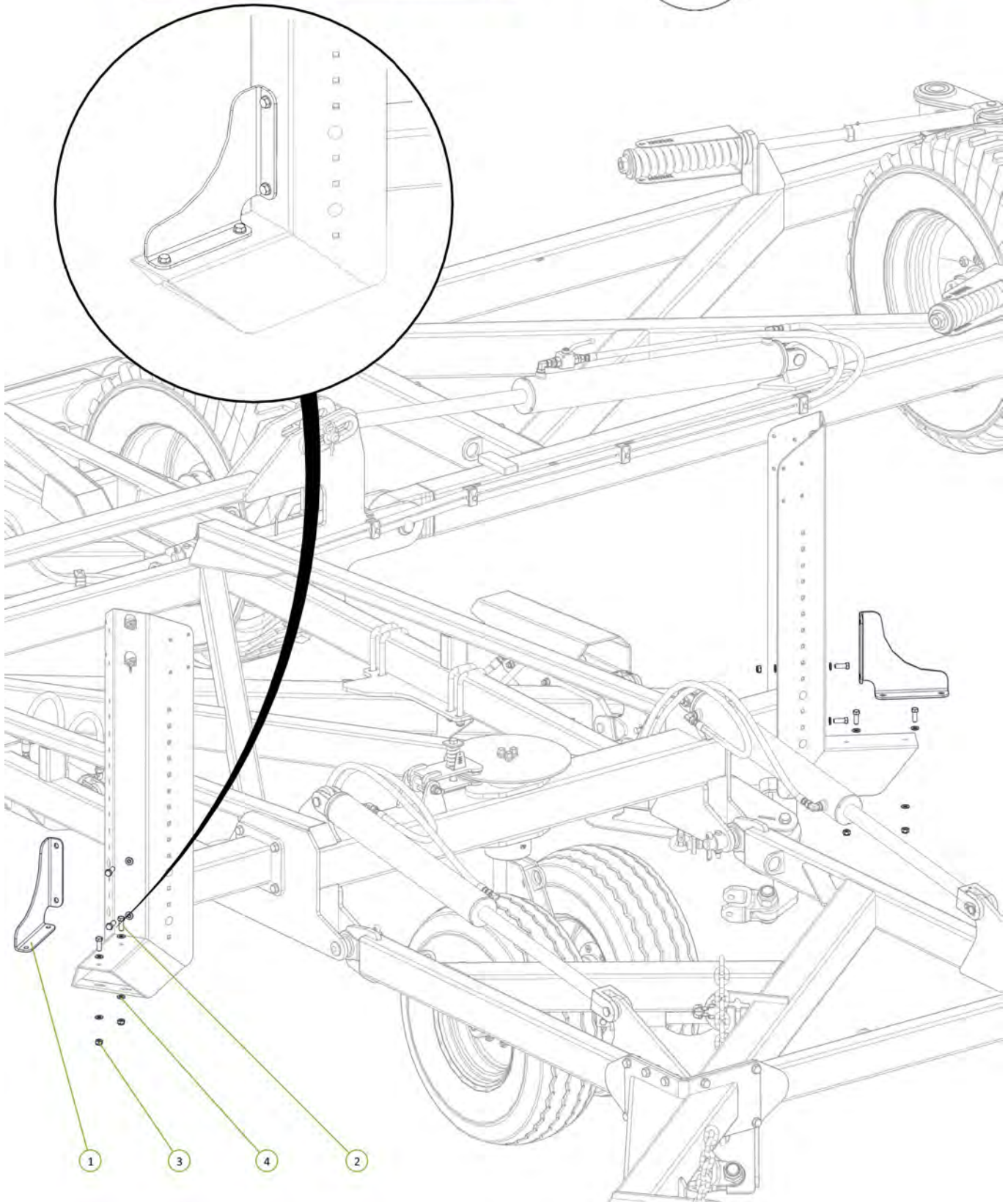

Item No.	Description	Number	Qty
1	AU Oversize Sign	0810-46	2
2	M12 x 65 Coach Head Bolt	0215-CH1265	6
3	Oversize Sign Left Hand	0801-SIGNOSL	1
4	Oversize Sign Right Hand	0801-SIGNOSR	1
5	Nyloc Nut M12	0221-NYL12	6
6	Washer Square M12 x 40 x 3	0231-SQ12403	6
8	TEK Screw 10g 16 x 16	0241-TEK10-1616	20

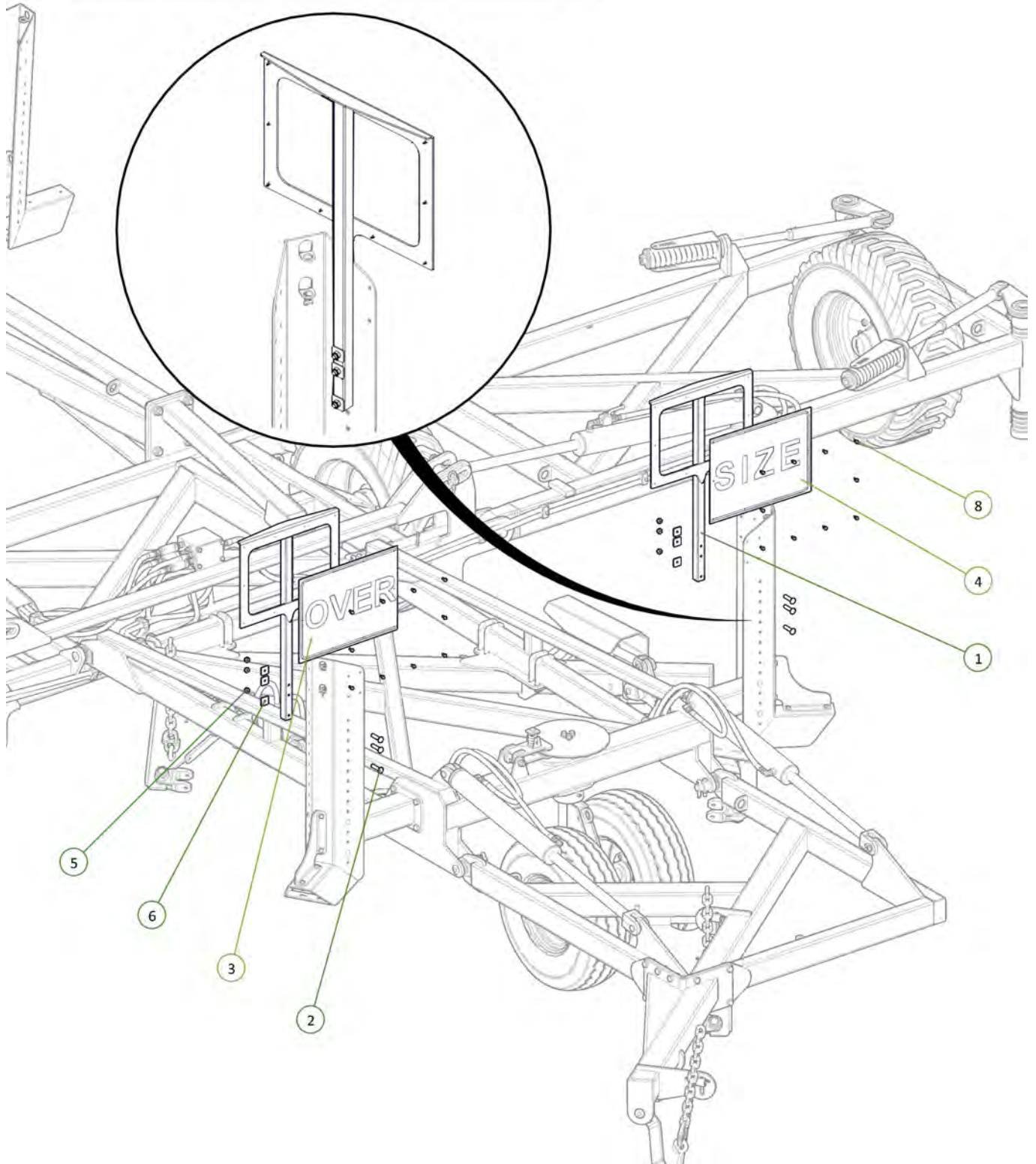

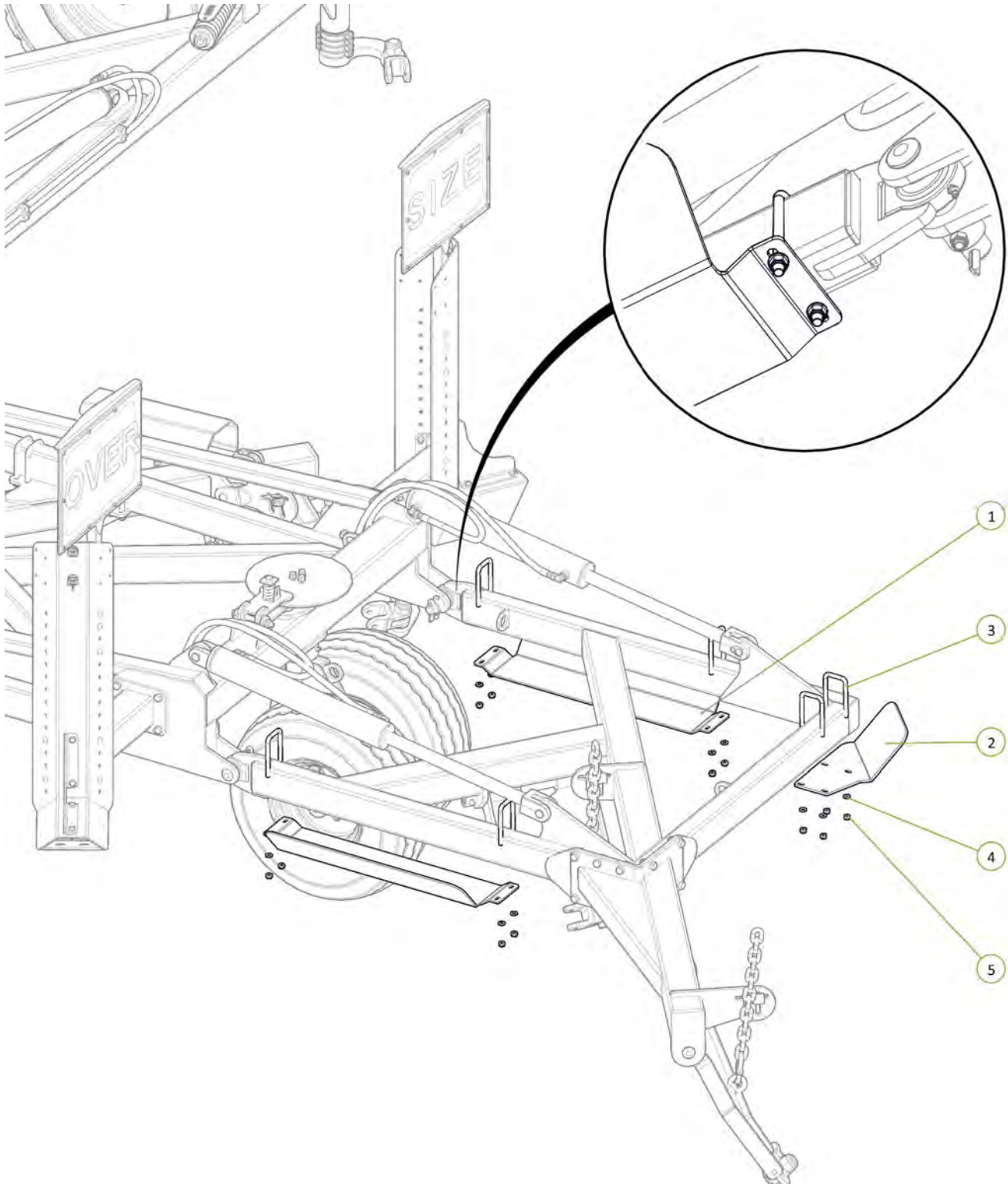

Item No.	Description	Number	Qty
1	Rear Tail Guard	0800-235	2
2	Angled Chain Gaurd	0800-498	1
3	U-Bolt M12 x 155 Deep x 77 Wide	0271-1215577	6
4	Washer Flat M12	0231-F12	12
5	Nyloc Nut M12	0221-NYL12	12



Item No.	Description	Number	Qty
1	Safety Chain Assembly	0810-16	1

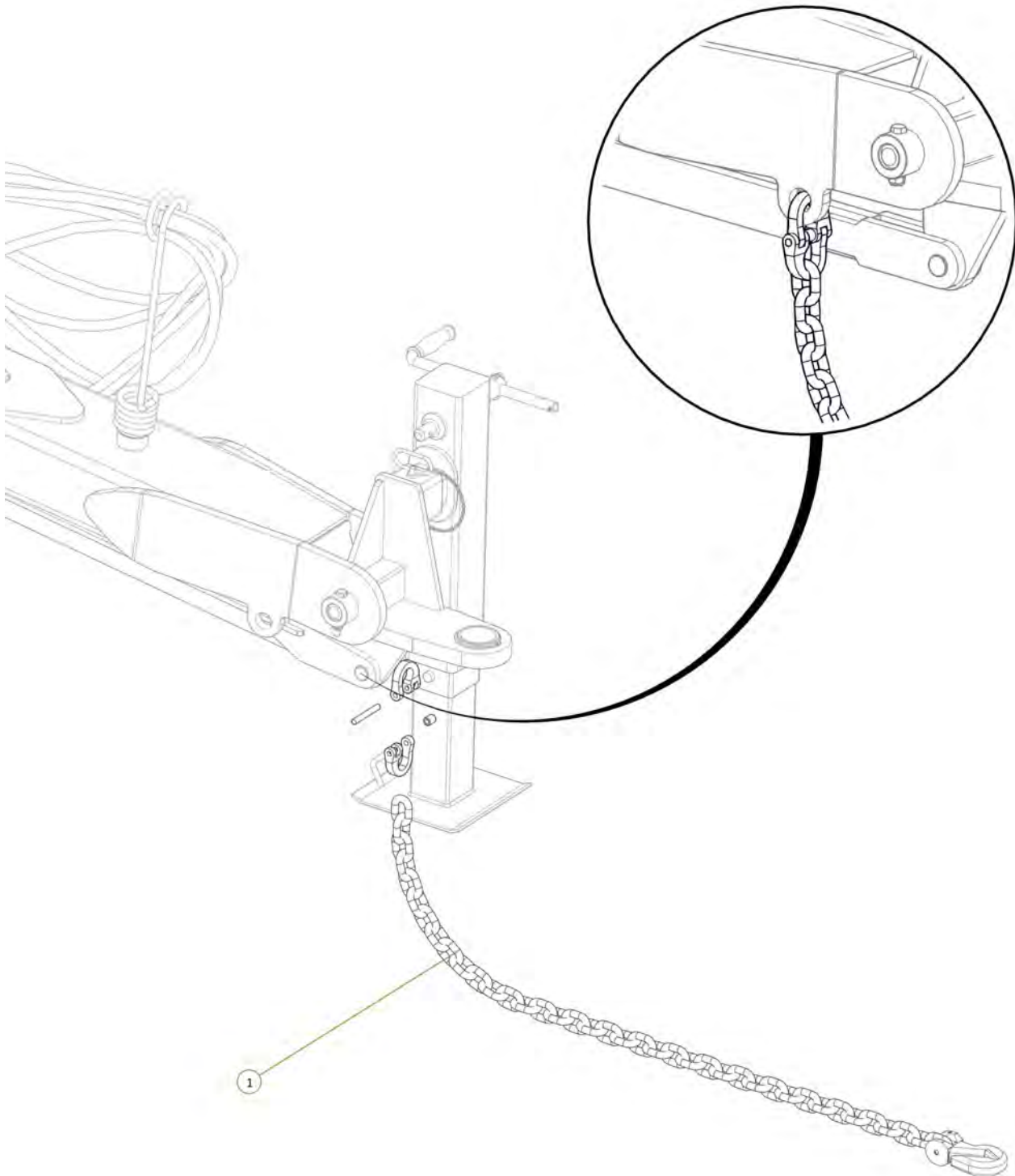

Item No.	Description	Number	Qty
1	Operator Manual Cannister	0801-OMC-1	1
2	Ratcheting Gear Wrench 1 3/4"	0802-GW1 3-4	1
3	20mm Bolt Swivel Unit	0802-PCHB55	1
4	M20 x 110 grade 10.9 ZP Short Thread Bolt	0211-20110ST	1
5	Nyloc Nut M20	0221-NYL20	1
6	M6 x 20 Trilobe self tapping ScREW	0211-M620MZPHTF	3

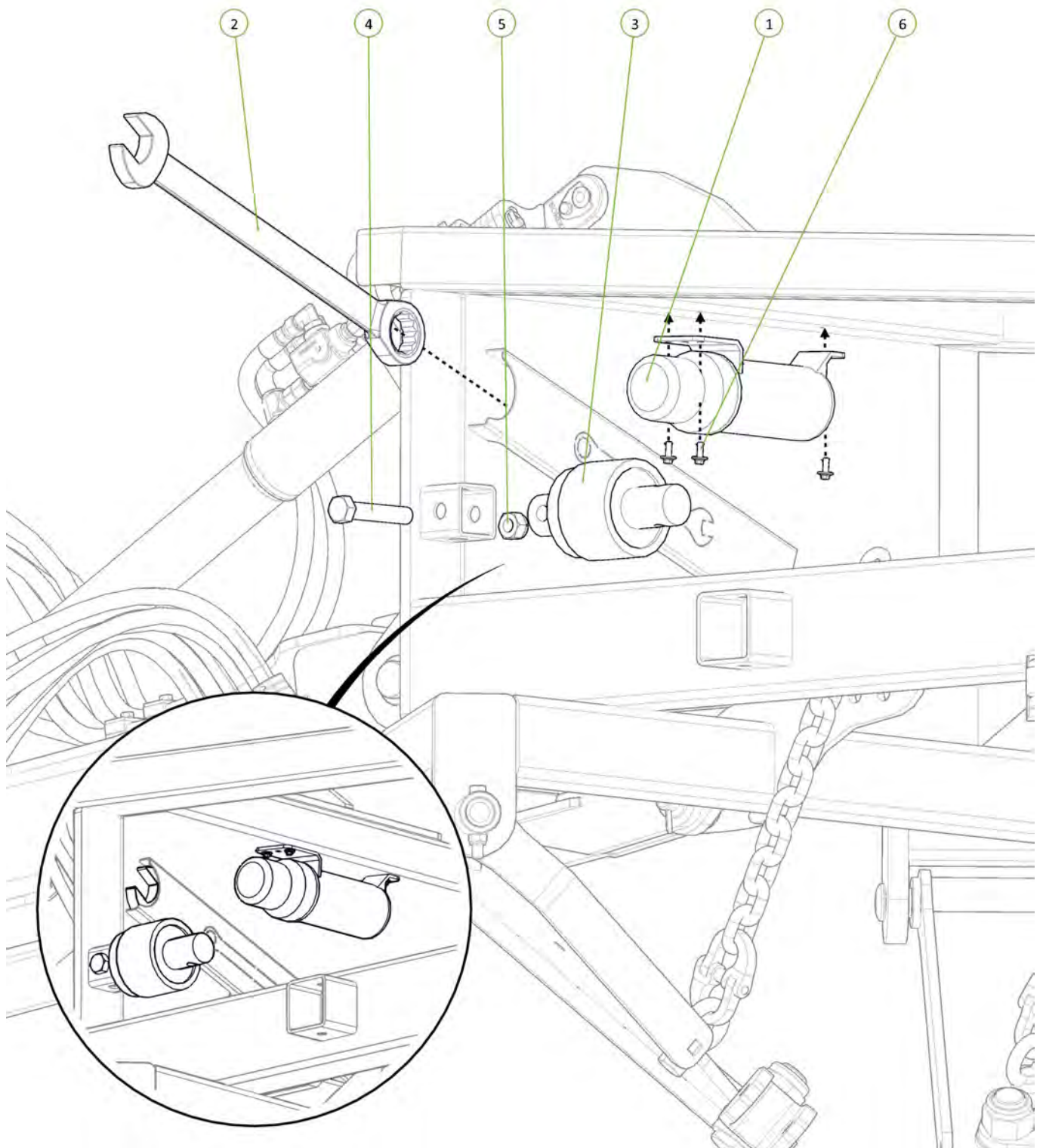
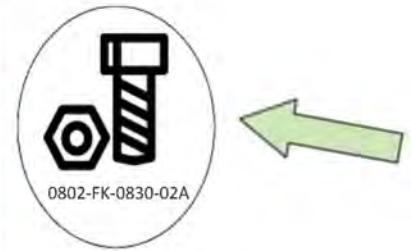

Item No.	Description	Number	Qty
1	Cylinder Safety Stop	0800-688	1
2	Square Loop Pin 5/16" x 3 1/4"	0511-PINLOOPSQ516x314	1

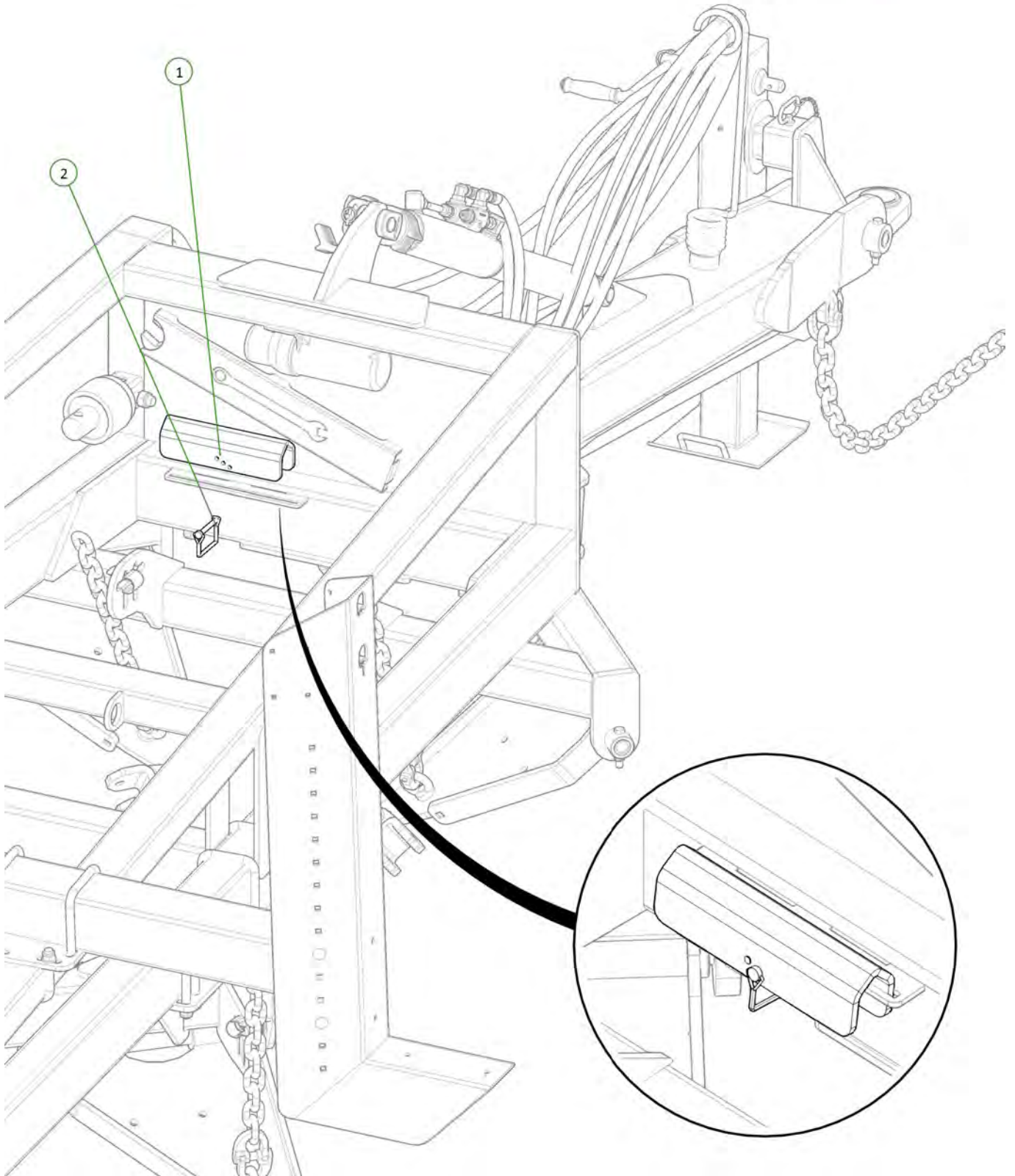

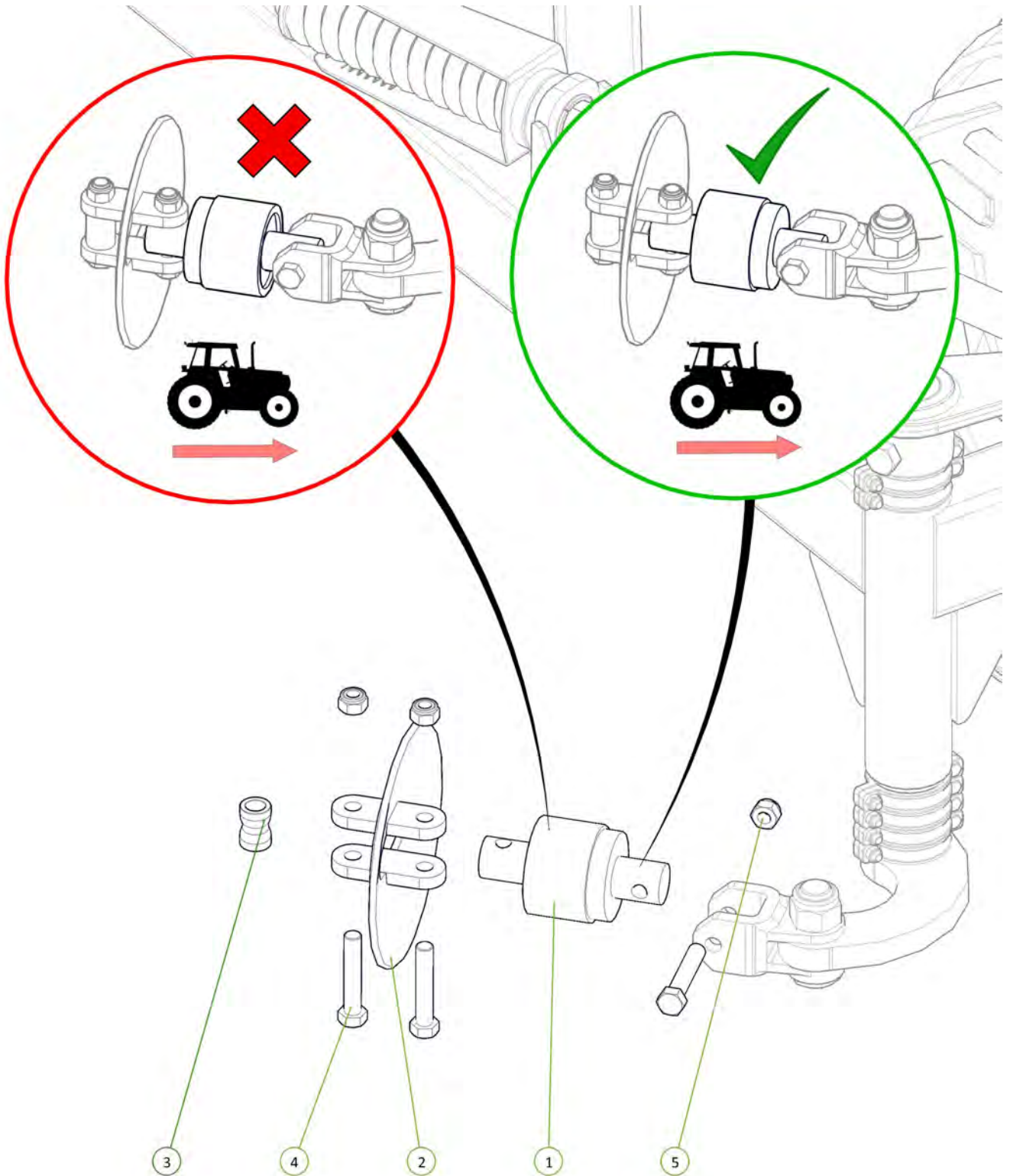

Item No.	Description	Number	Qty
1	20mm Bolt Swivel Unit	0802-PCHB55	1
2	Disc Chain Tie Plate Link 20mm	0802-DCTP-20	1
3	Disc Chain Spacer	0801-253755	1
4	M20 x 110 grade 10.9 ZP Short Thread Bolt	0211-20110ST	3
5	Nyloc Nut M20	0221-NYL20	3

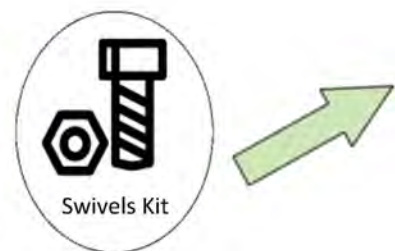

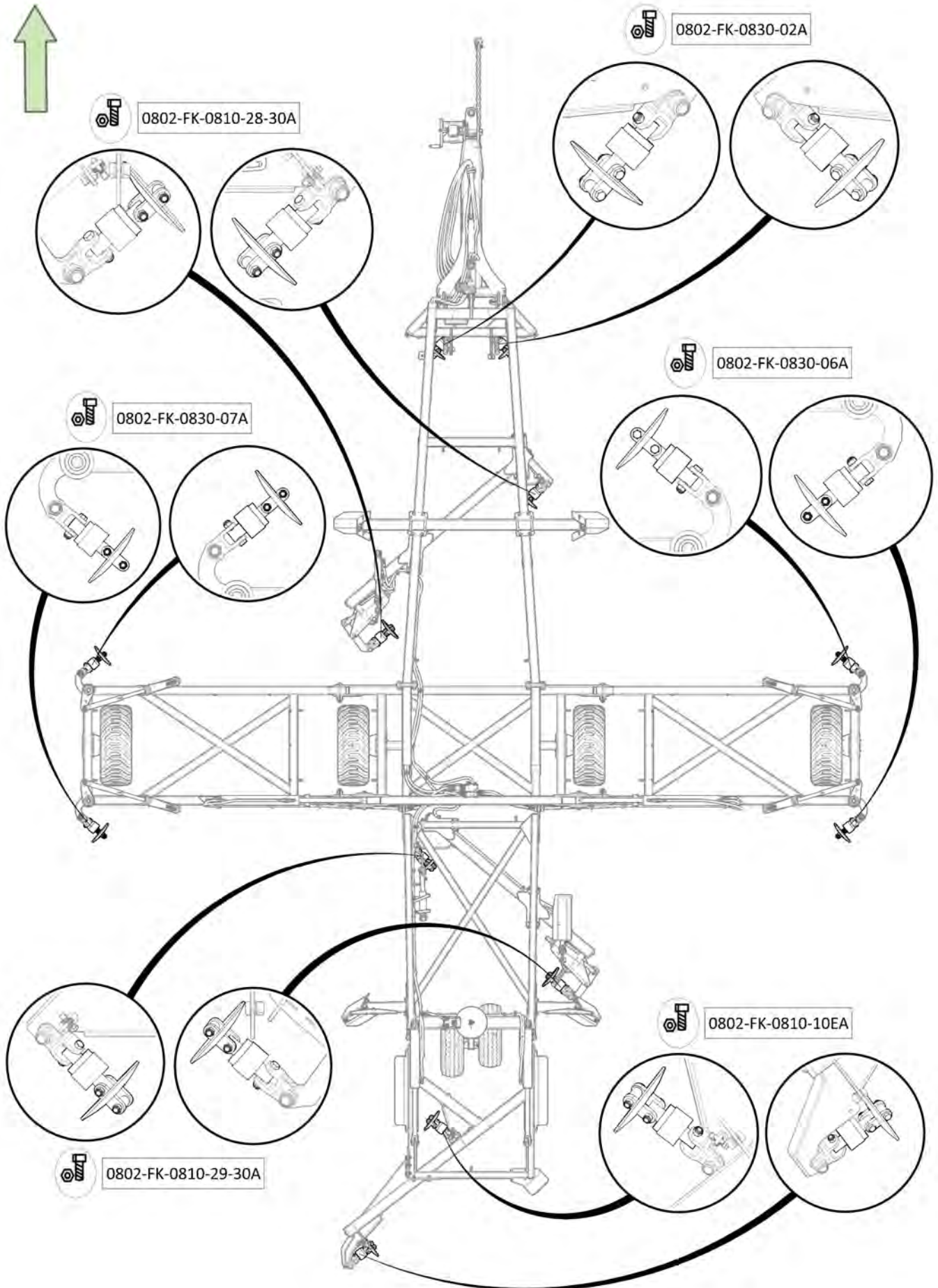

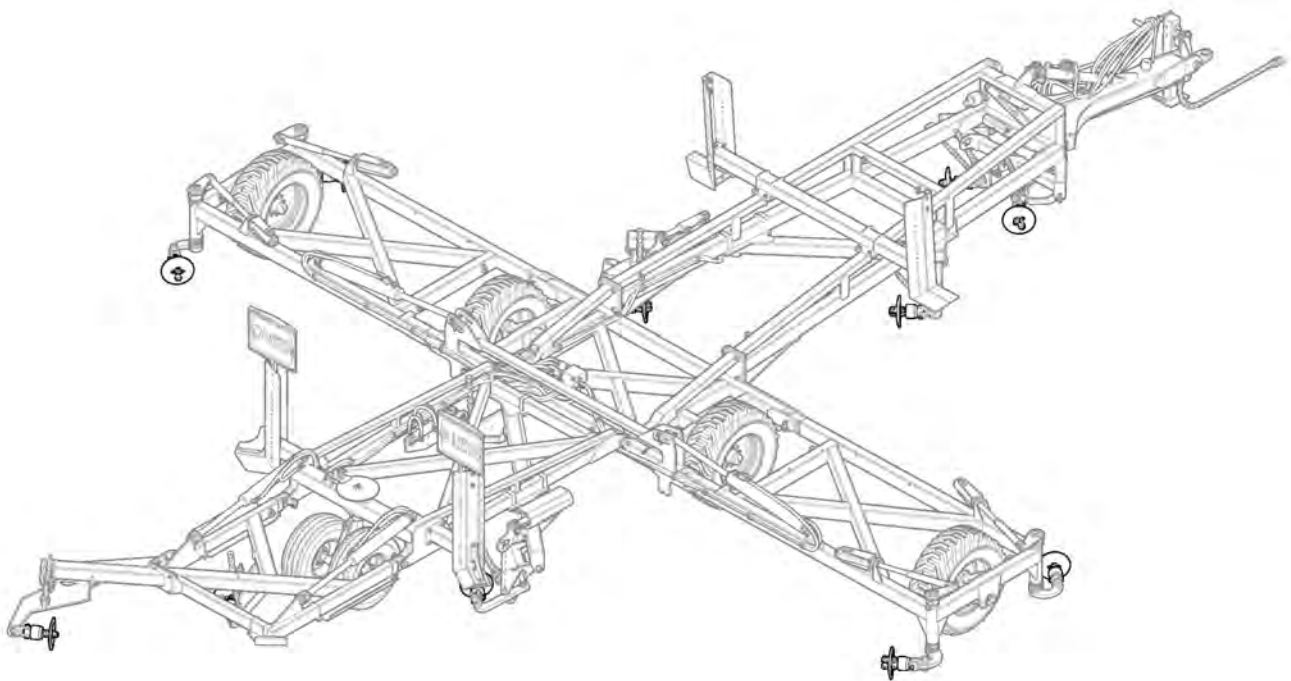

Ensure all bearings are correctly orientated with seals facing the rear of the machine

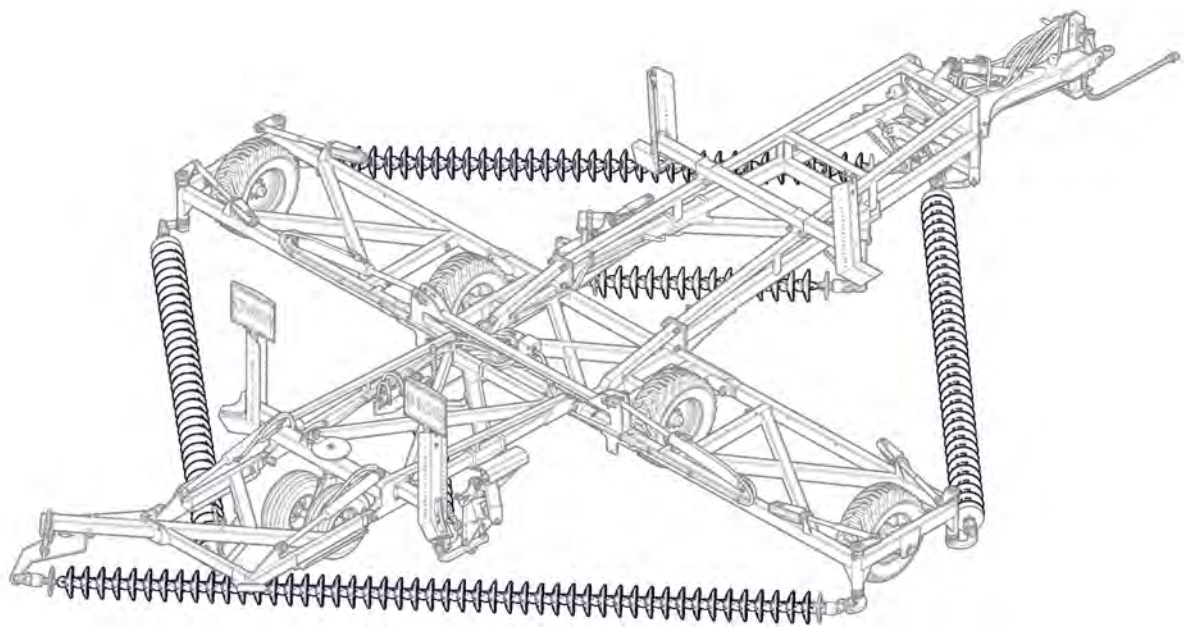

Section 3 - Decal Placement

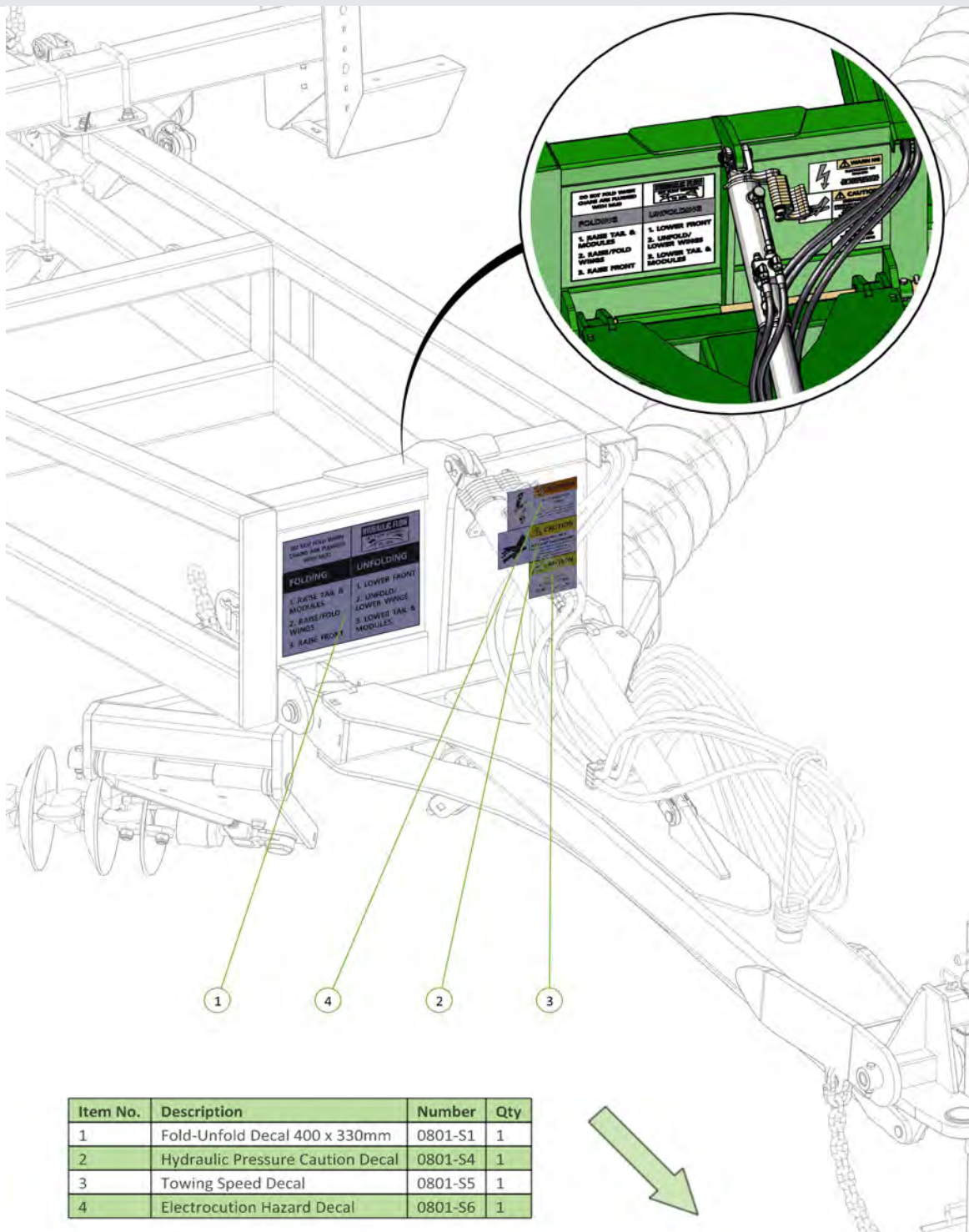

Item No.	Description	Number	Qty
1	Fold-Unfold Decal 400 x 330mm	0801-S1	1
2	Hydraulic Pressure Caution Decal	0801-S4	1
3	Towing Speed Decal	0801-S5	1
4	Electrocution Hazard Decal	0801-S6	1

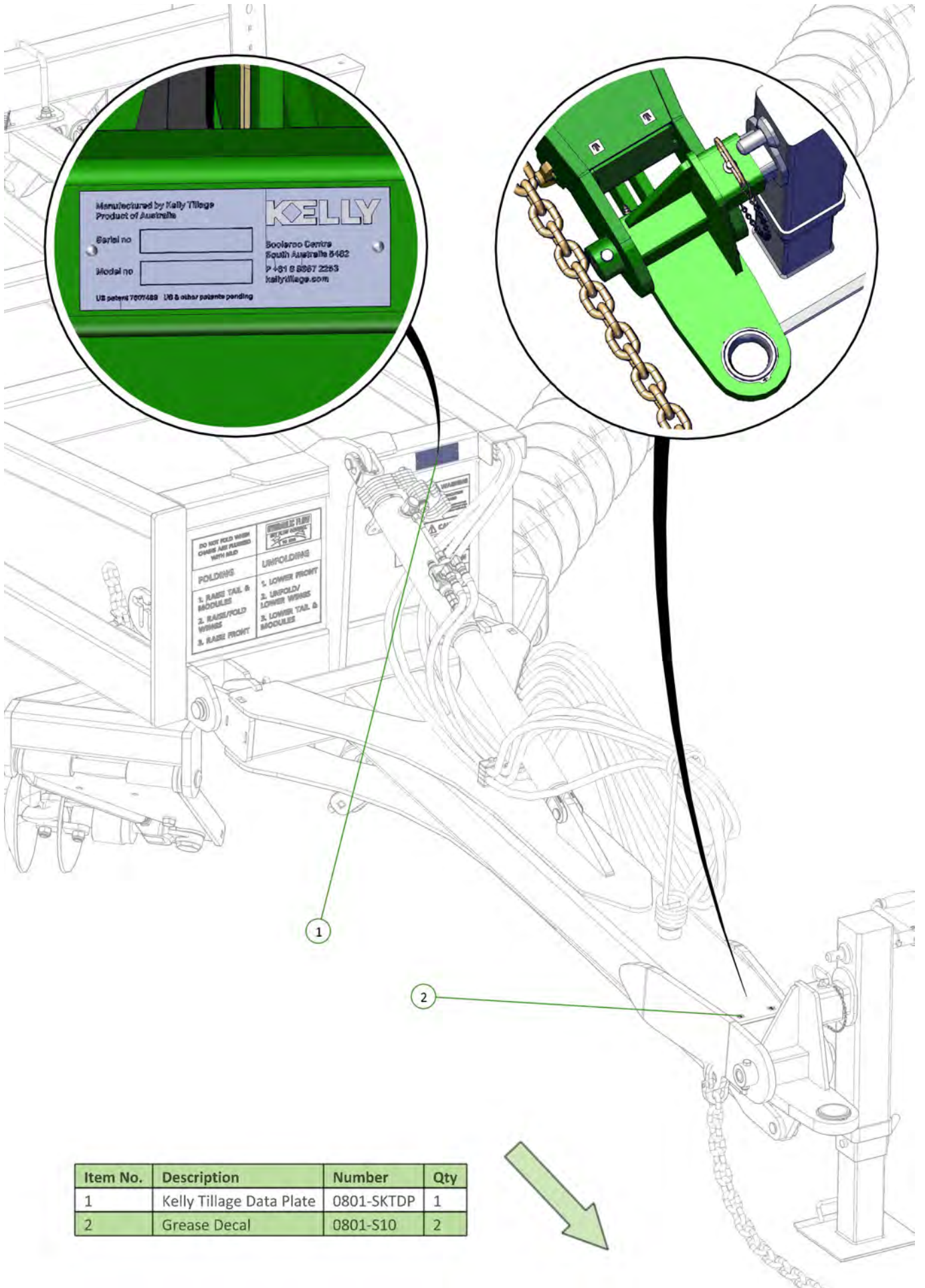

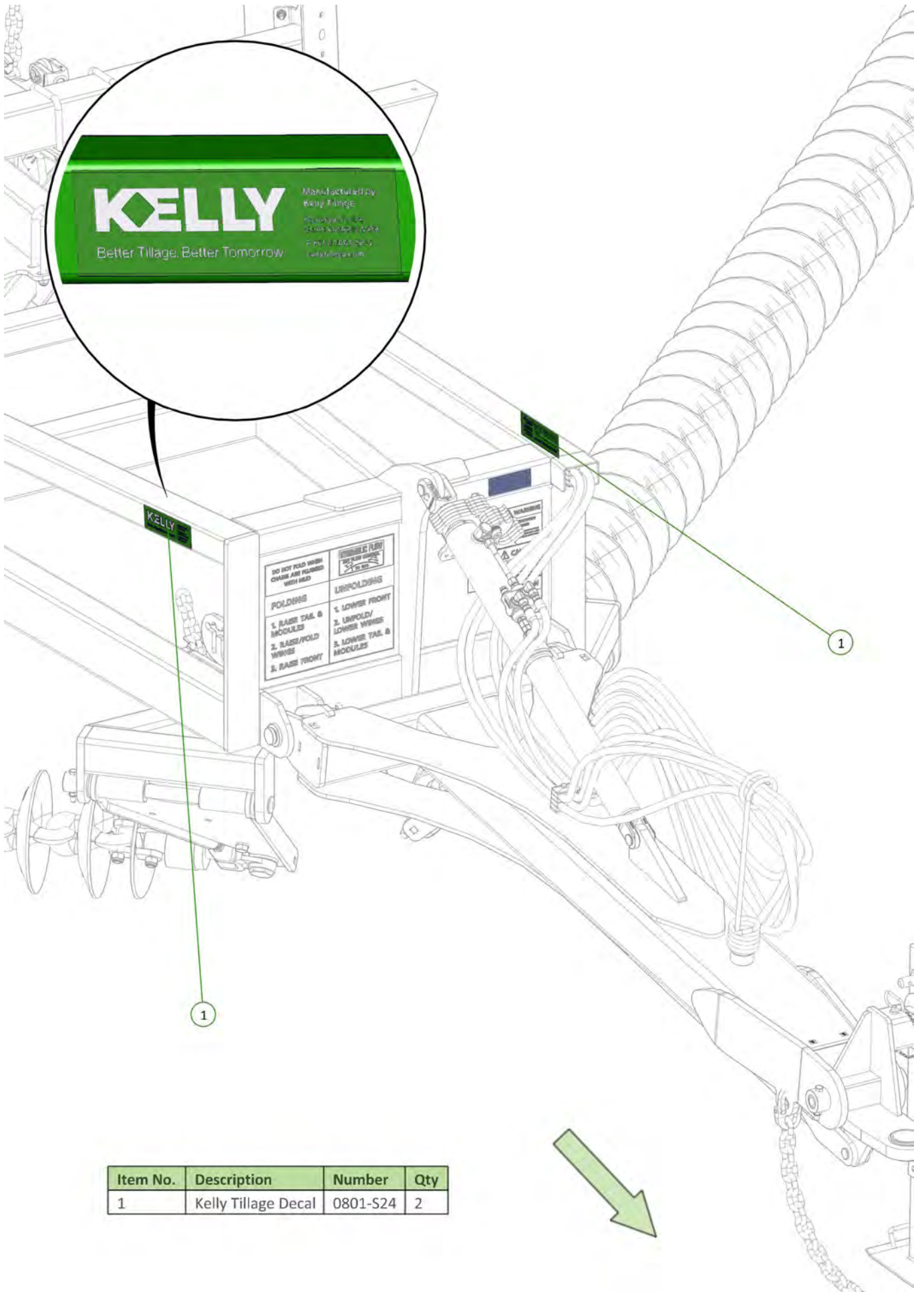

DO NOT FOLD WHEN CHANGING AIR PRESSURE WITH HEAD

FOLDING

1. RAISE TAIL & MODULES
2. RAISE/FOLD WINGS
3. RAISE FRONT

UNFOLDING

1. LOWER FRONT
2. UNFOLD/LOWER WINGS
3. LOWER TAIL & MODULES

Item No.	Description	Number	Qty
1	Kelly Tillage Decal	0801-S24	2



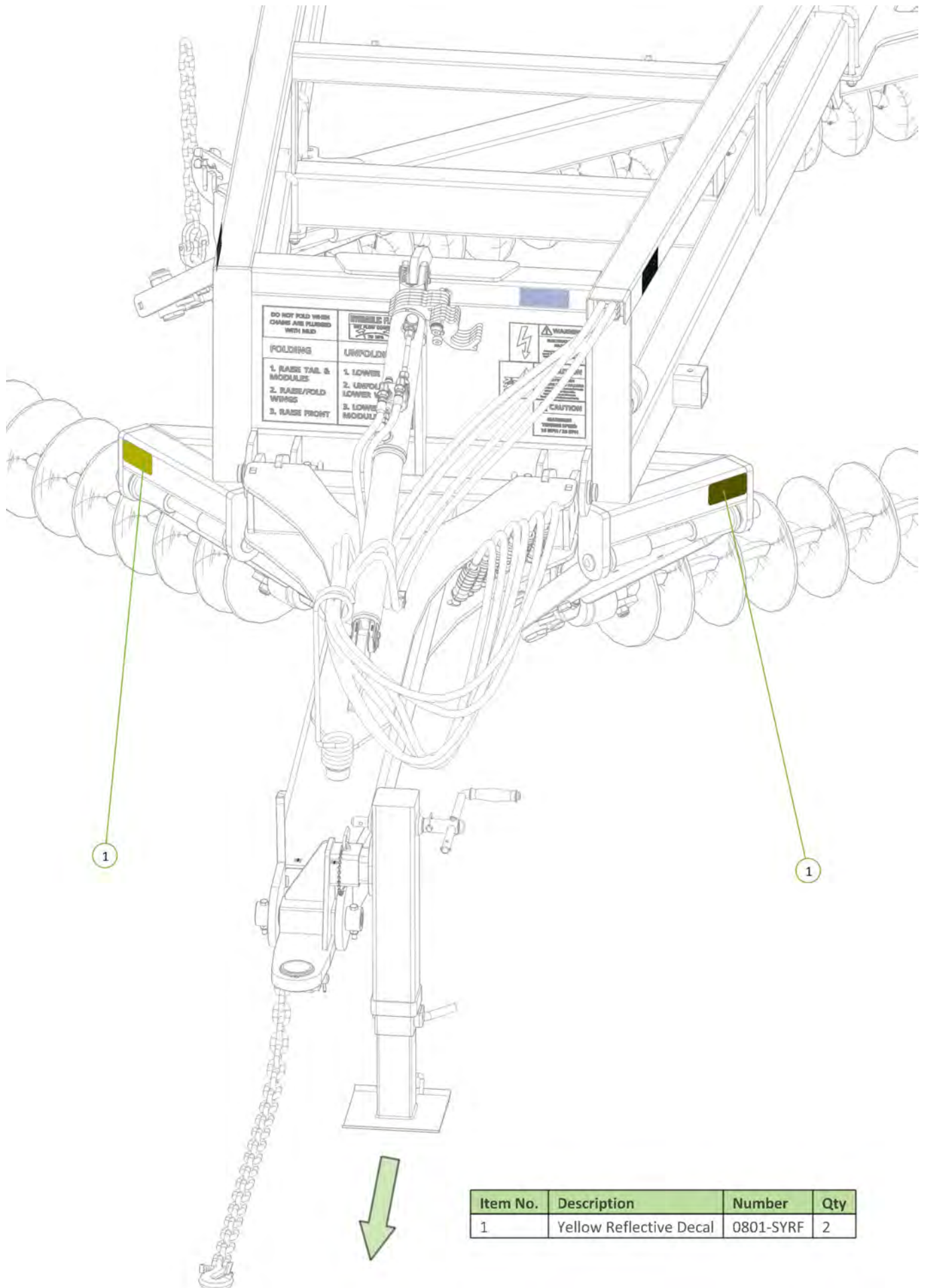

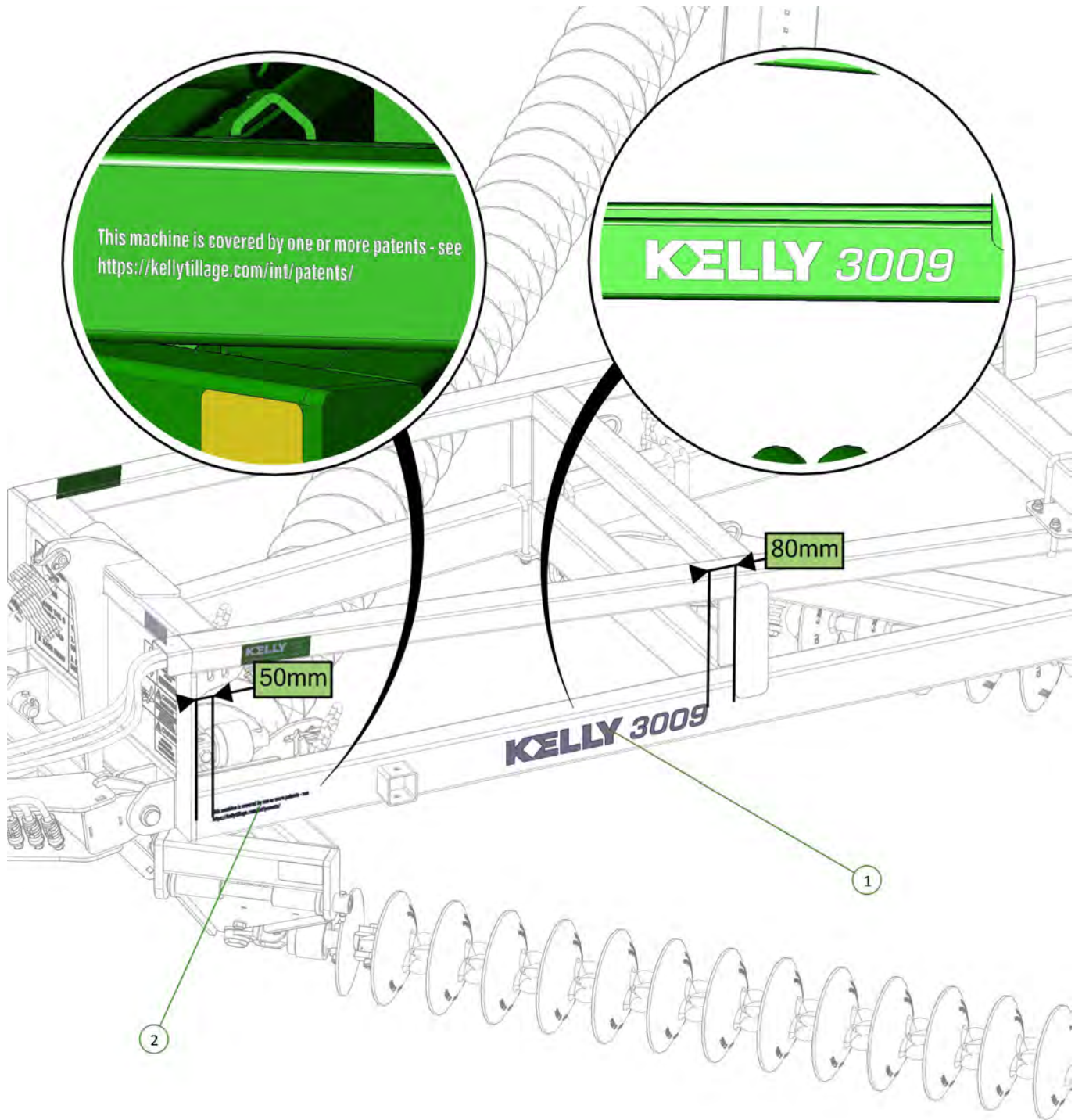

Item No.	Description	Number	Qty
1	Kelly Tillage 3009 Decal	0801-SKT3009	1
2	Universal Patent Decal	0801-S26	1



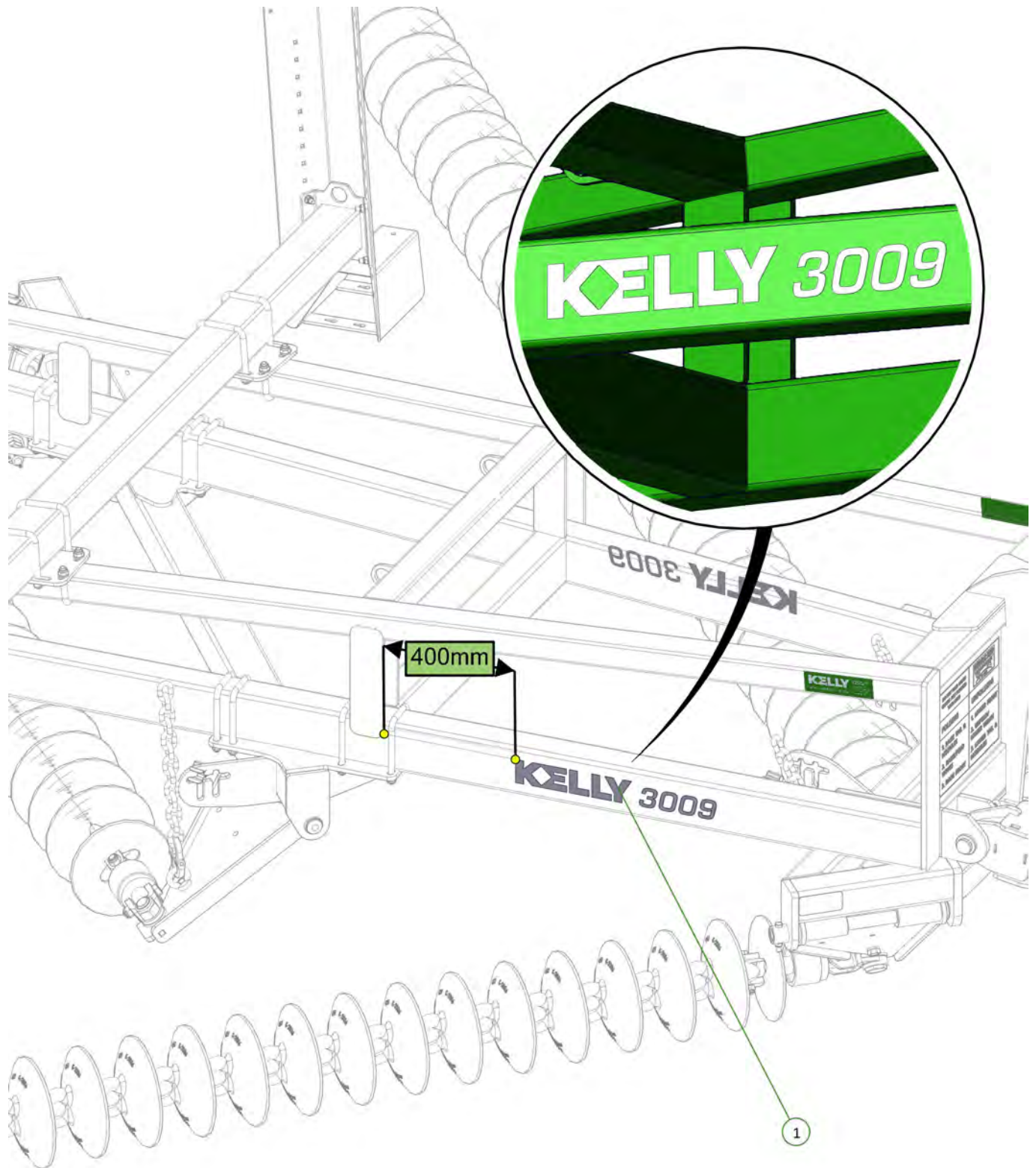

Item No.	Description	Number	Qty
1	Kelly Tillage 3009 Decal	0801-SKT3009	1



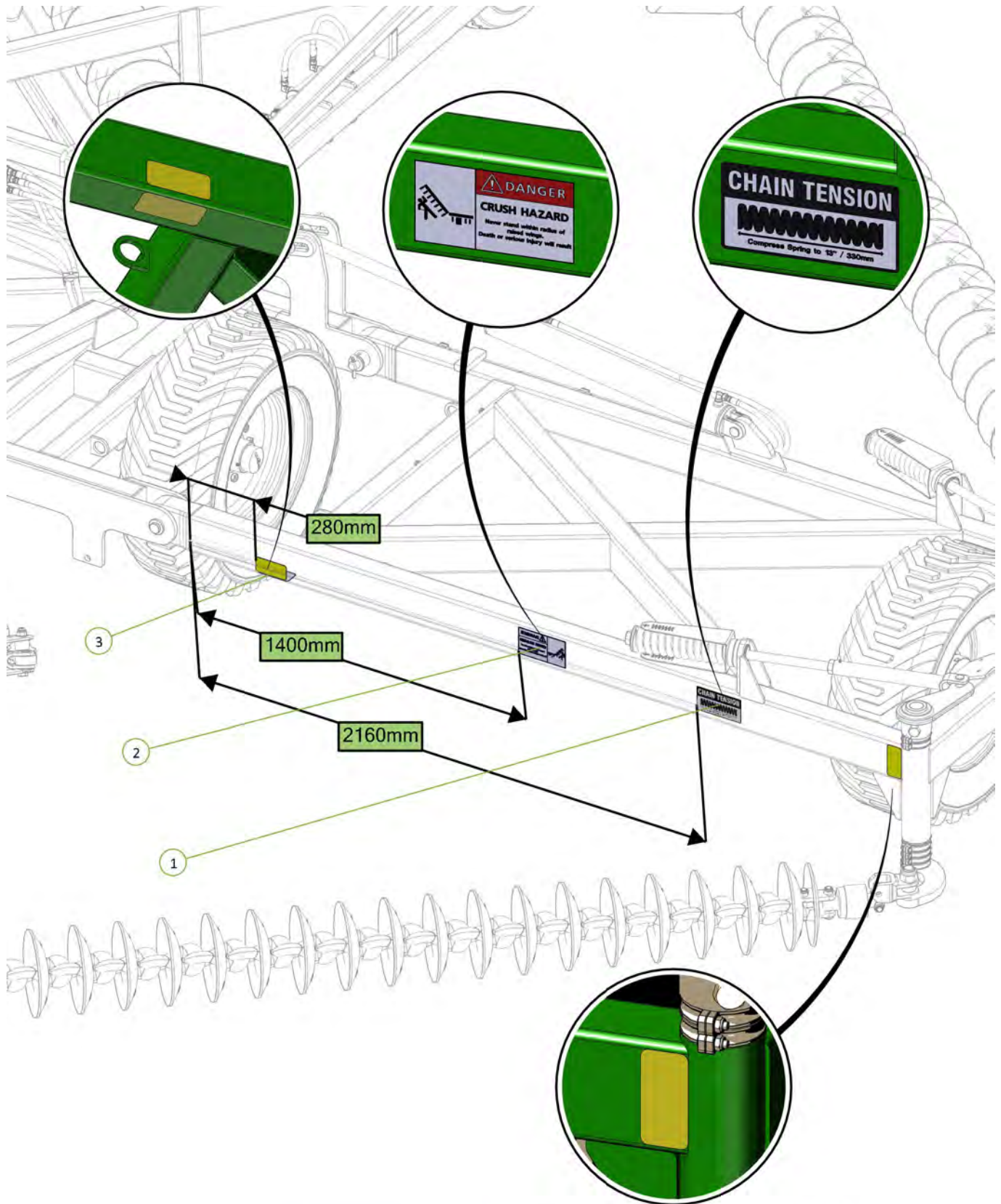

Item No.	Description	Number	Qty
1	Chain Tension 330mm Decal	0801-S15	1
2	Danger Crush Hazard Decal	0801-S3	1
3	Yellow Reflective Decal	0801-SYRF	3

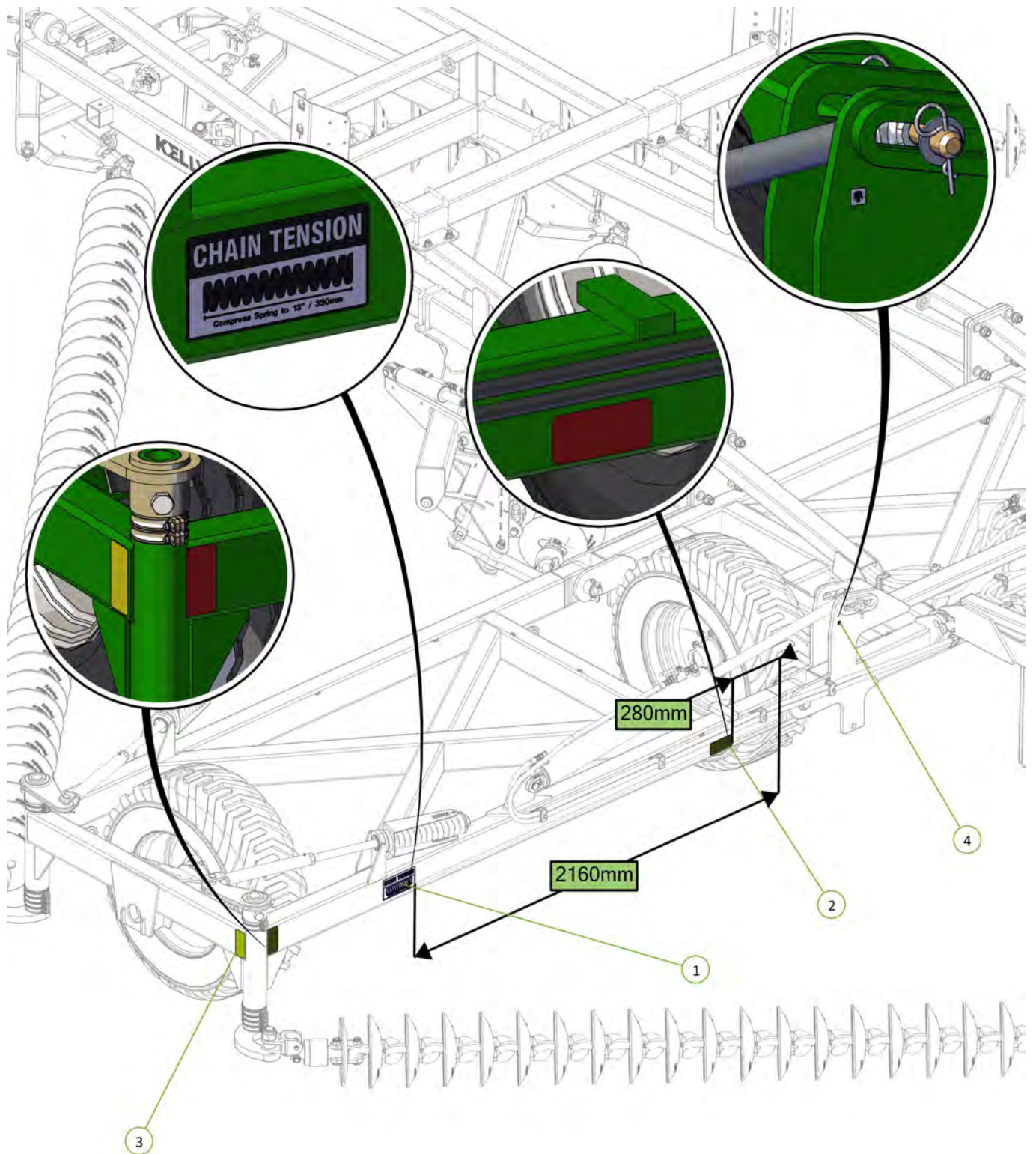

Item No.	Description	Number	Qty
1	Chain Tension 330mm Decal	0801-S15	1
2	Red Reflective Decal	0801-SRRF	2
3	Yellow Reflective Decal	0801-SYRF	1
4	Grease Decal	0801-S10	1



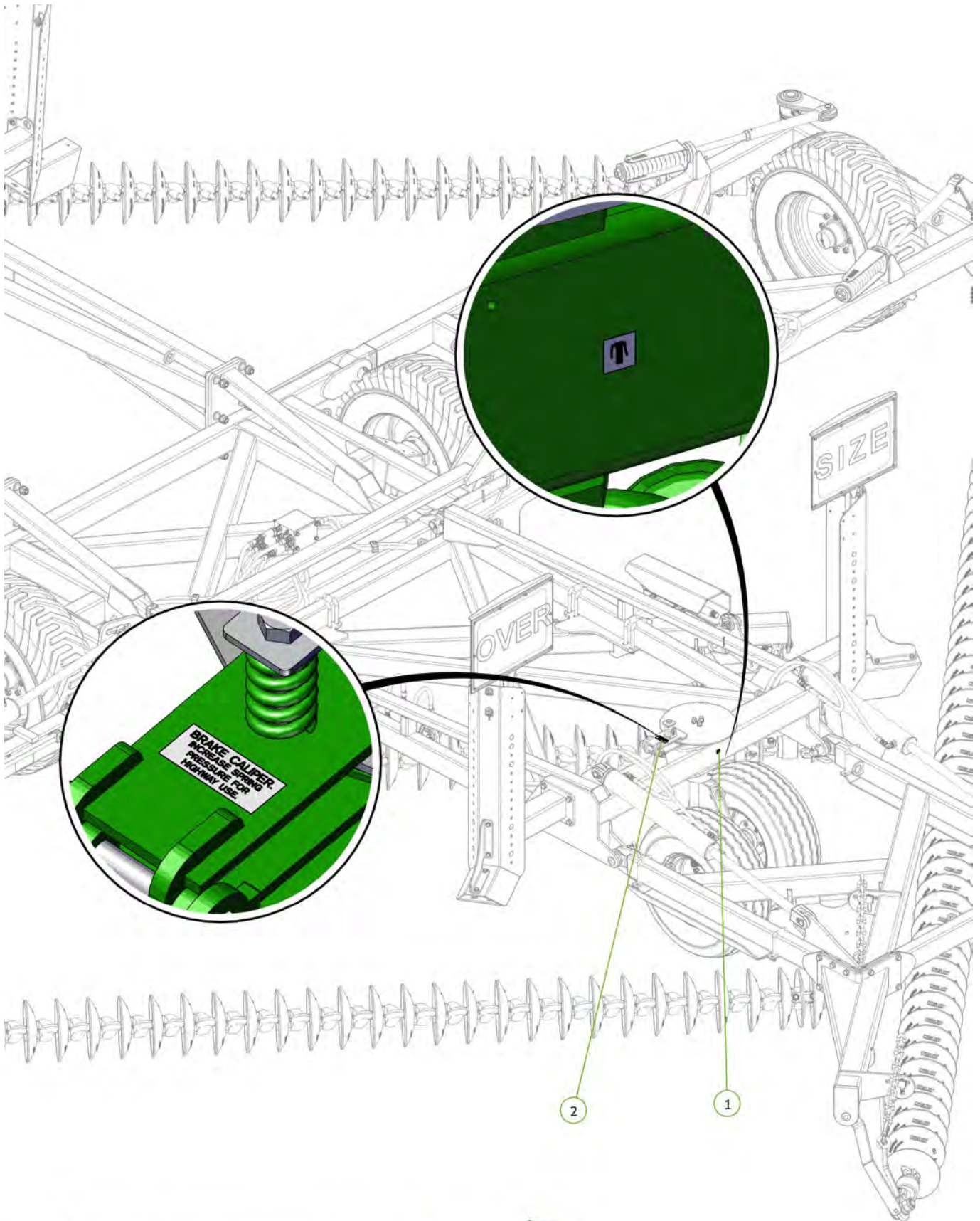

Item No.	Description	Number	Qty
1	Grease Decal	0801-S10	1
2	Brake Caliper Decal	0801-S11	1



Item No.	Description	Number	Qty
1	Yellow Reflective Decal	0801-SYRF	1

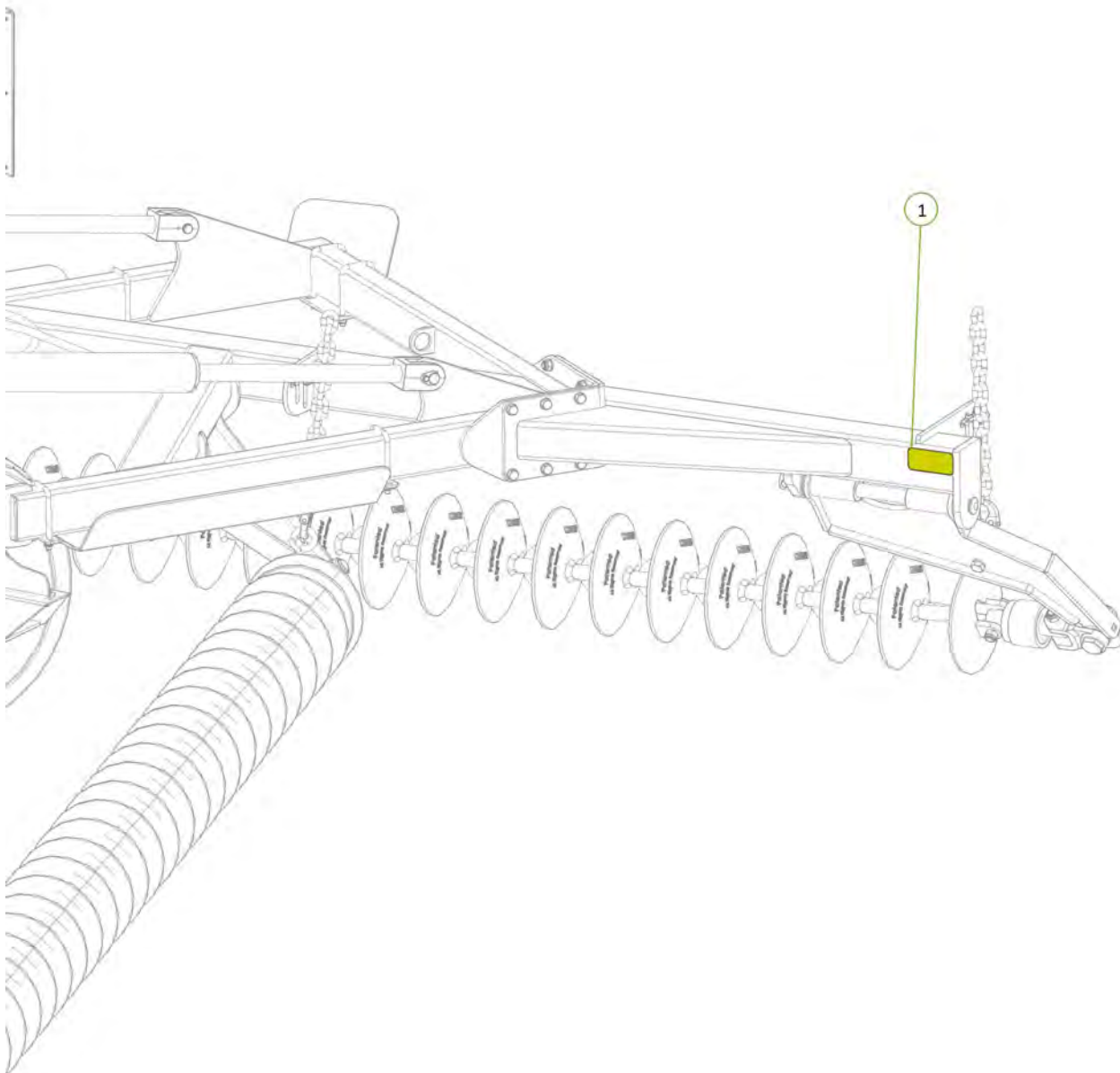

Item No.	Description	Number	Qty
1	Yellow Reflective Decal	0801-SYRF	1

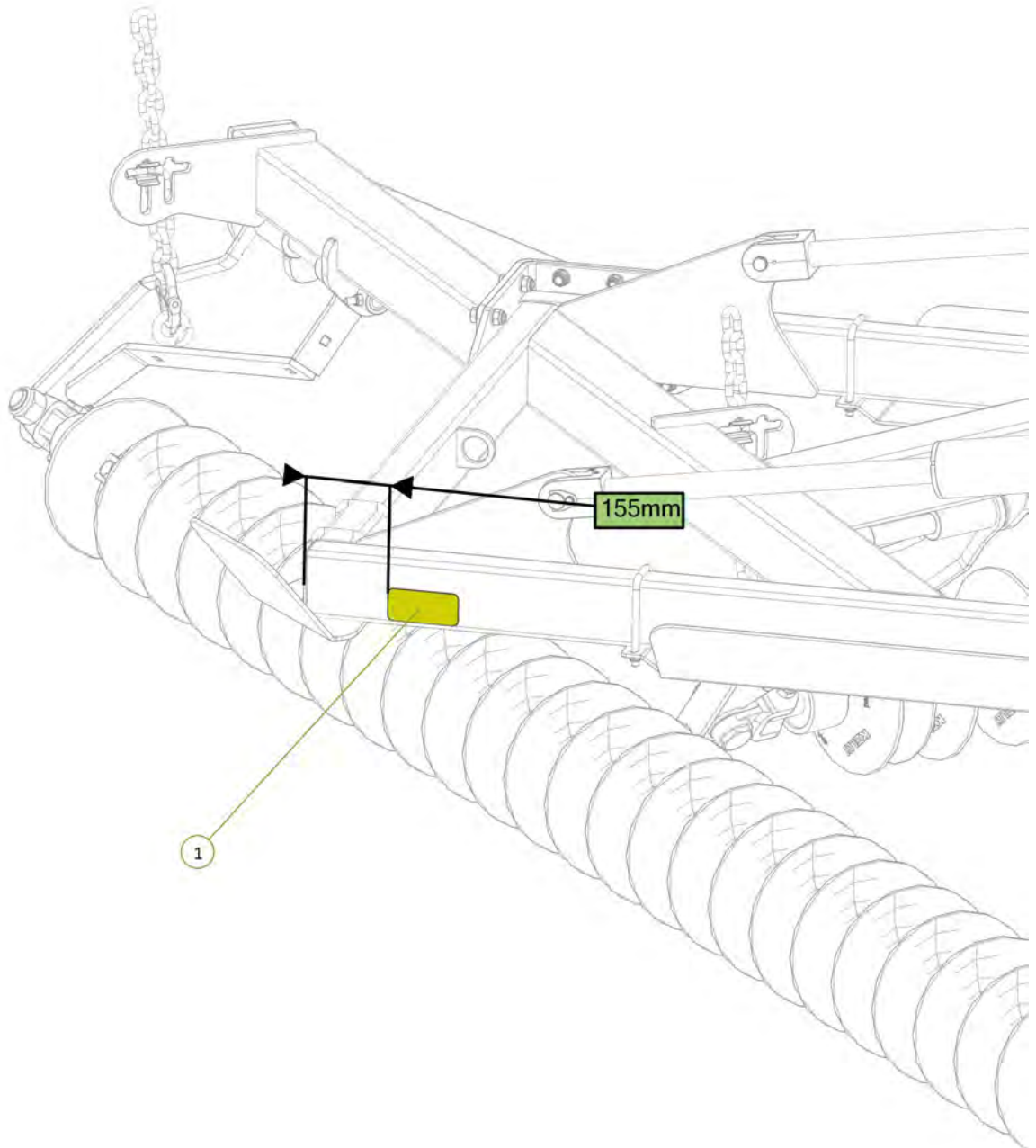

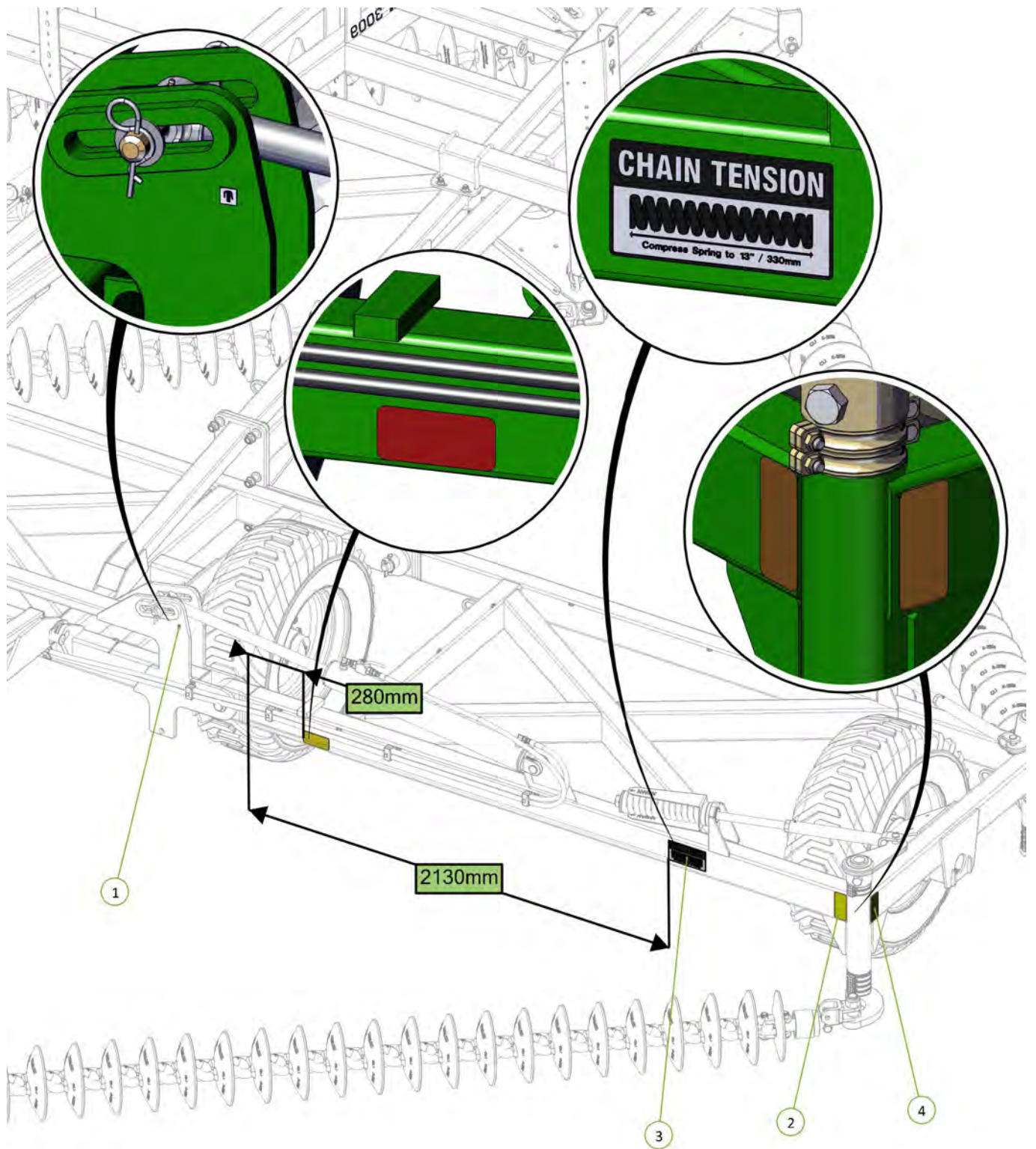

Item No.	Description	Number	Qty
1	Grease Decal	0801-S10	1
2	Red Reflective Decal	0801-SRRF	2
3	Chain Tension 330mm Decal	0801-S15	1
4	Yellow Reflective Decal	0801-SYRF	1



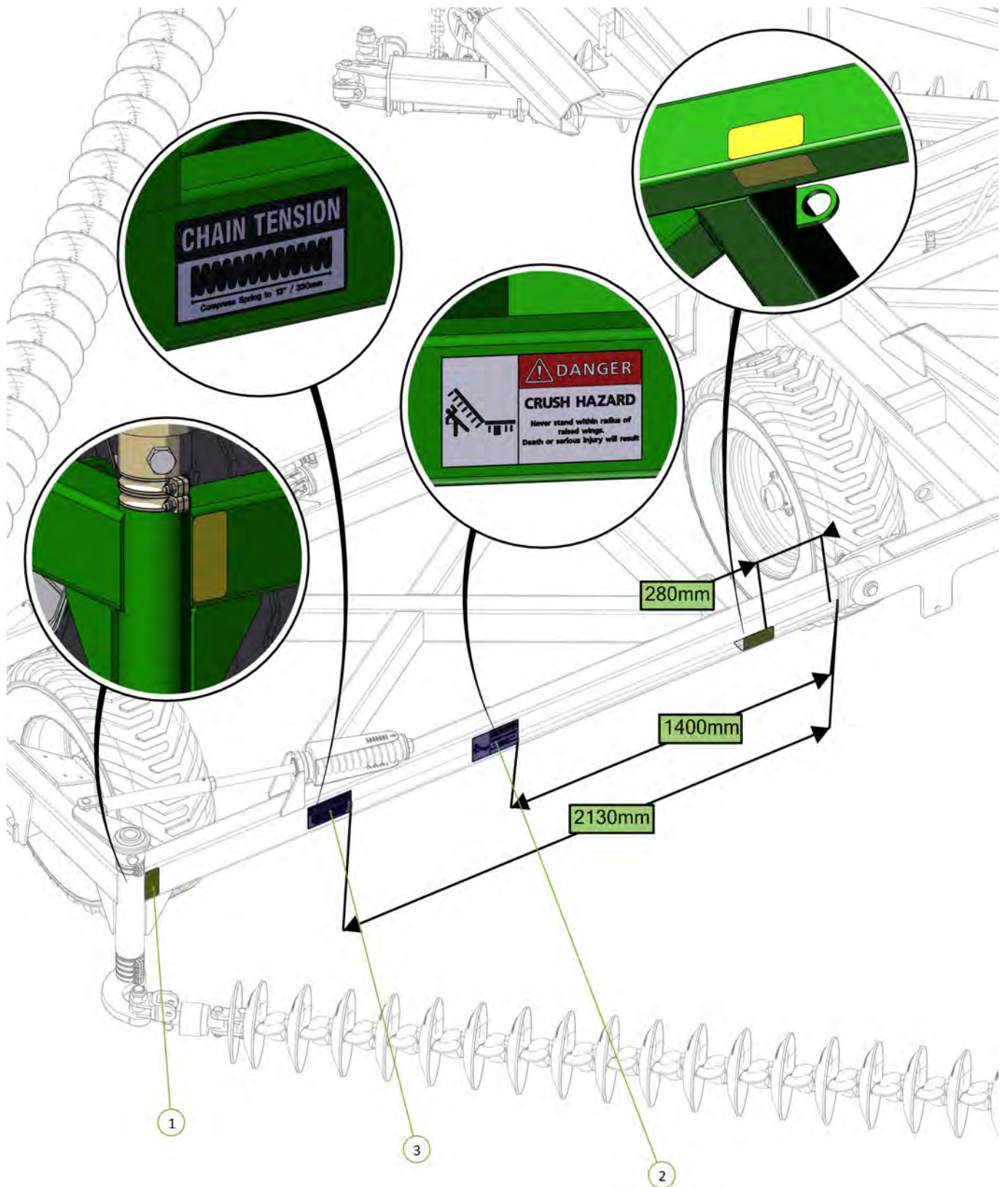

Item No.	Description	Number	Qty
1	Yellow Reflective Decal	0801-SYRF	3
2	Danger Crush Hazard Decal	0801-S3	1
3	Chain Tension 330mm Decal	0801-S15	1



Item No.	Description	Number	Qty
1	Decal, 11L-15 Tyre Inflation	0801-S8-11L-15	1
2	Decal, 400/55/22.5 Tyre Inflation	0801-S8-400-55-22.5	1
3	Wheel Nut Decal	0801-S9	1

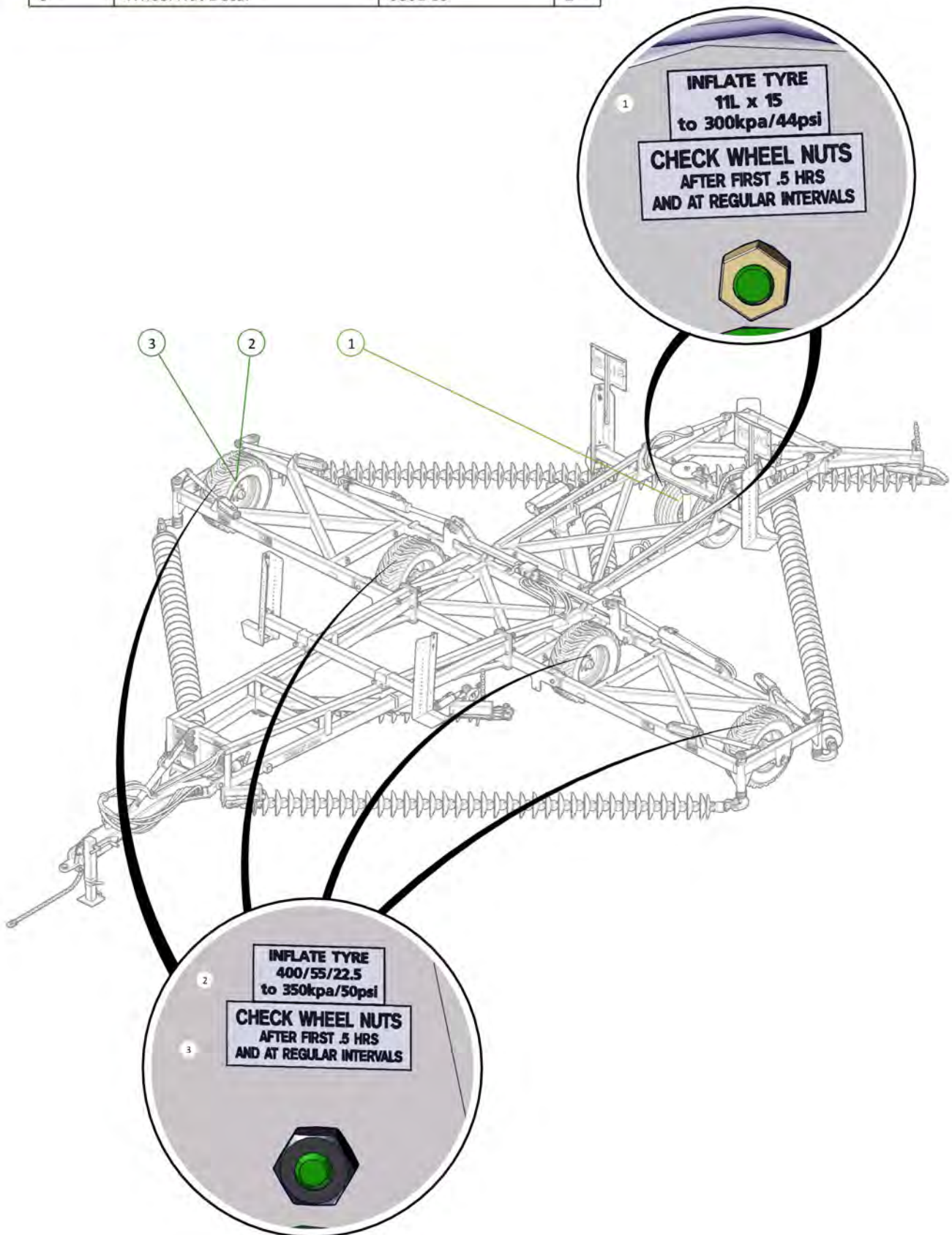

Item No.	Description	Number	Qty
1	4 Year Frame Warranty Decal AU	2001-00001	1

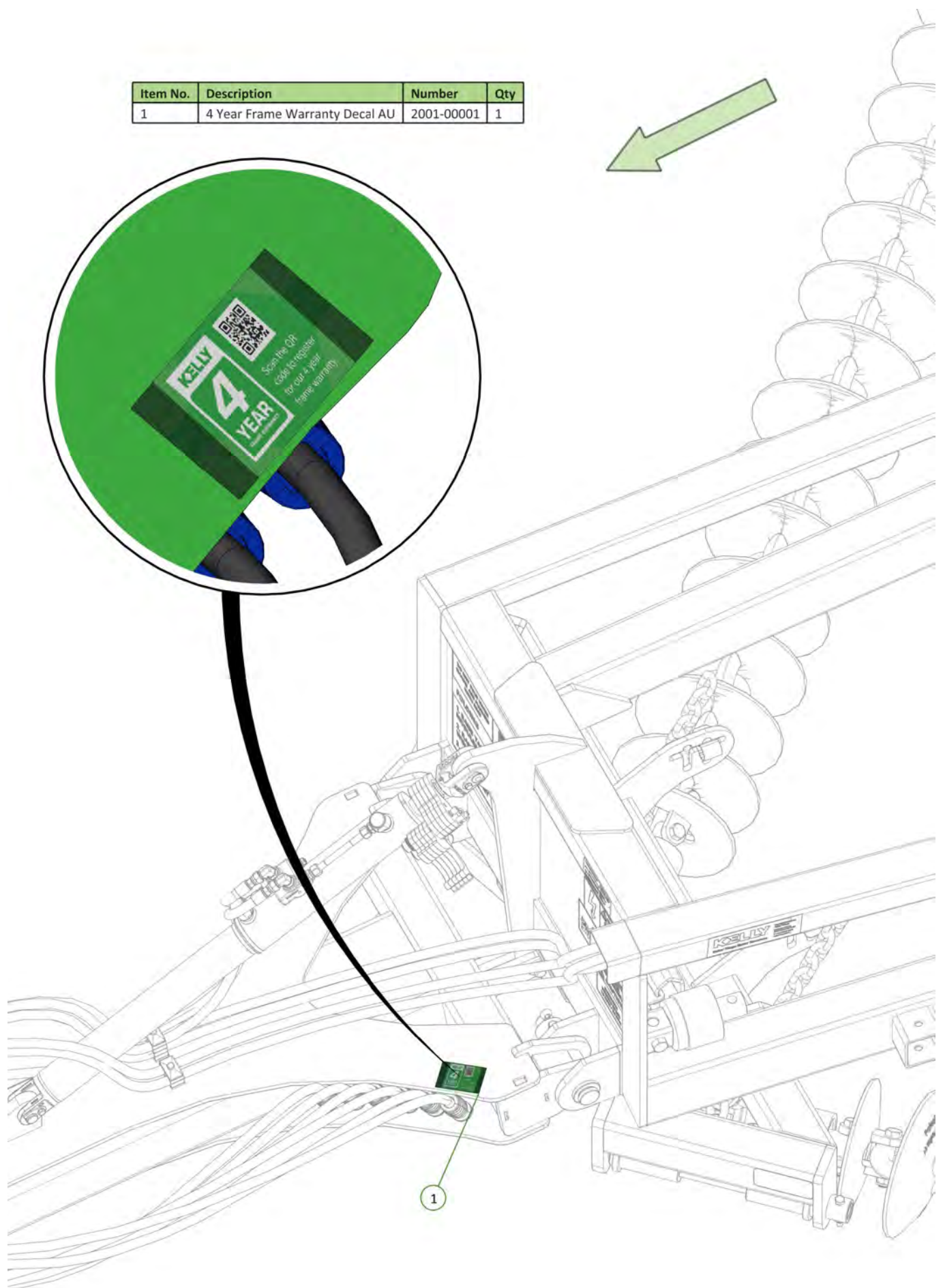

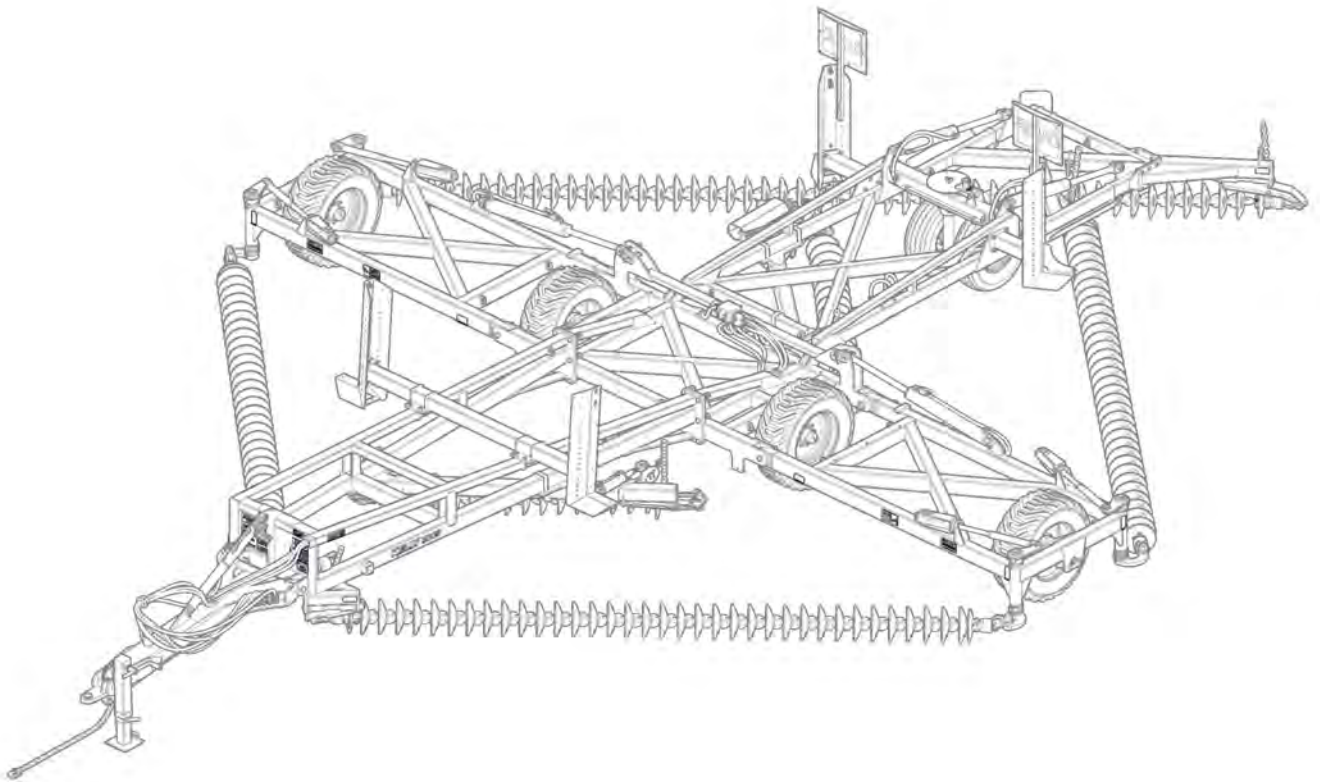

KELLY

Section 4 - Light Kit



Item No.	Description	Number	Qty
1	Wing light bracket	0800-296	2
2	Socket Head Bolt M6 x 170 zp	0211-SH6170	8
3	Nyloc Nut M6	0221-NYL6	2

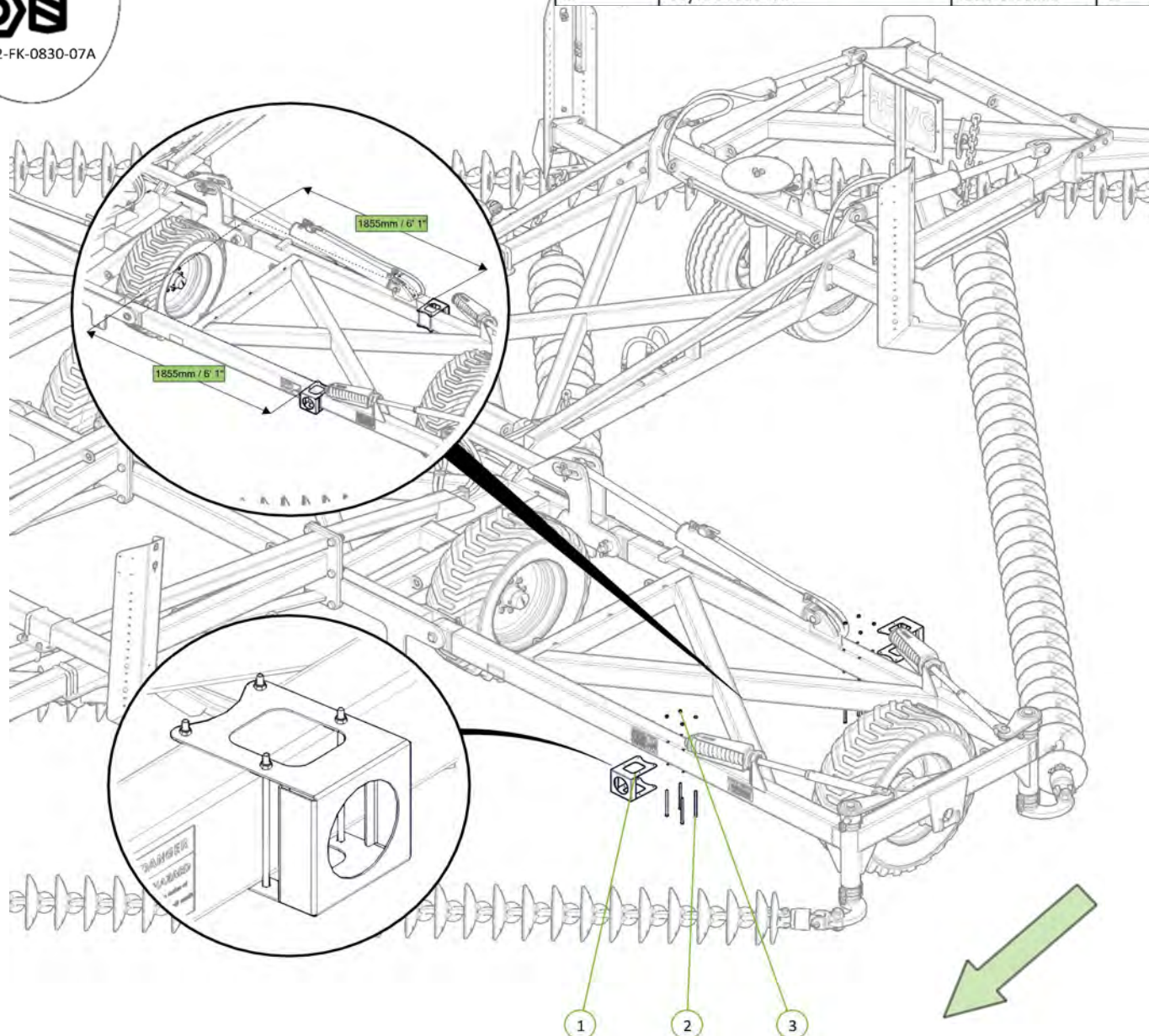

Item No.	Description	Number	Qty
1	Wing light bracket	0800-296	2
2	Socket Head Bolt M6 x 170 zp	0211-SH6170	8
3	Nyloc Nut M6	0221-NYL6	8

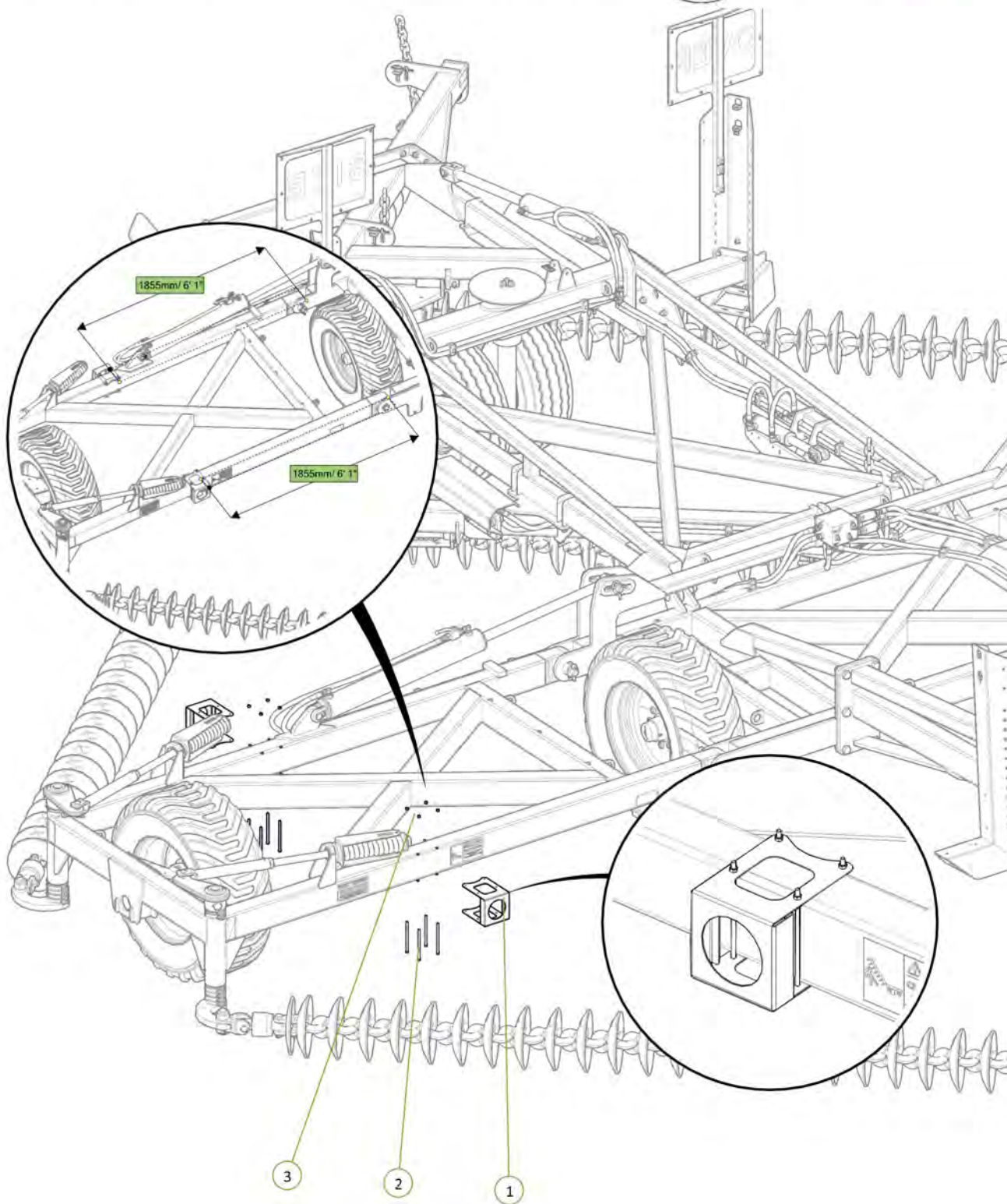

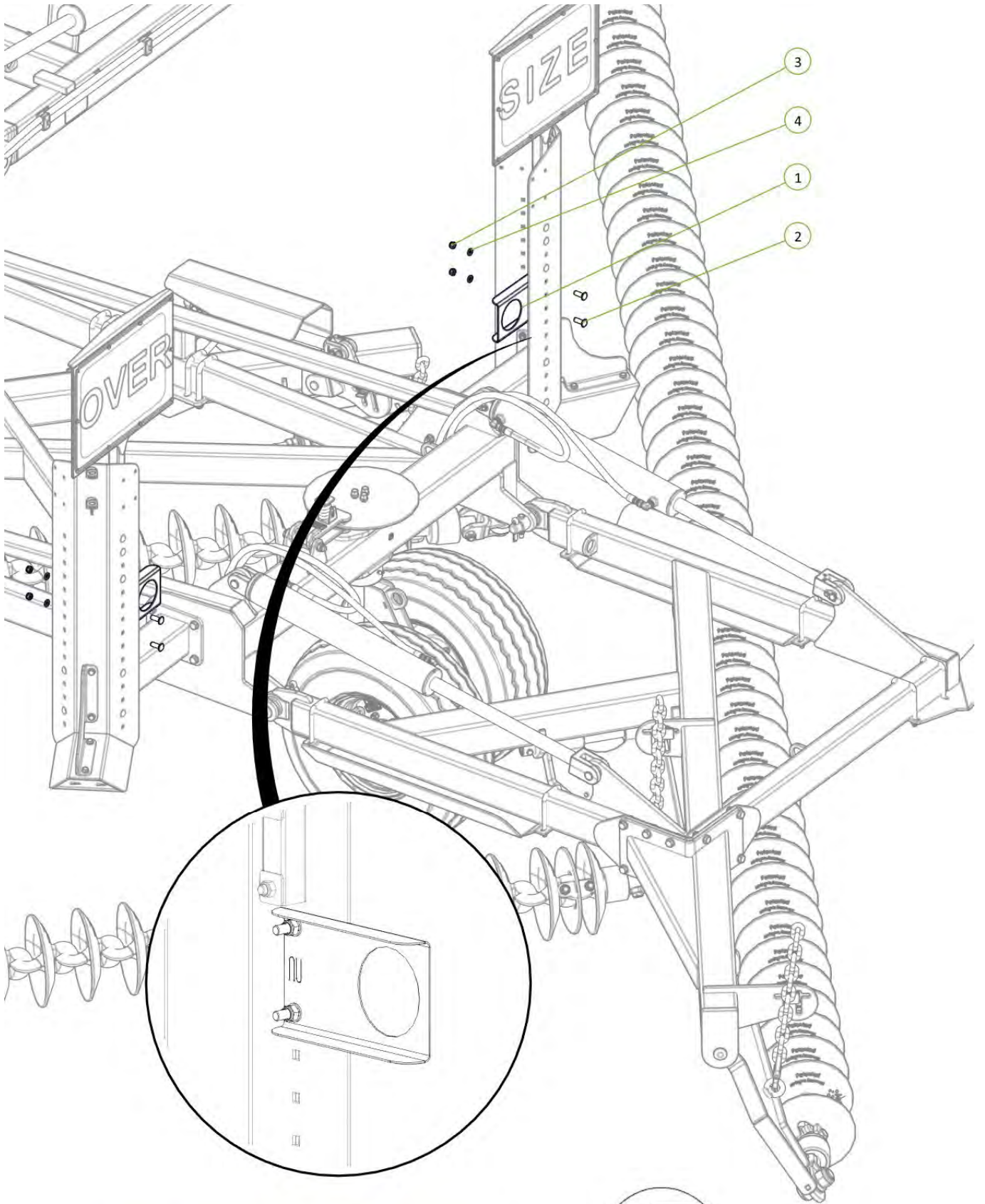

Item No.	Description	Number	Qty
1	Extended Light Bracket	0800-631	2
2	M12 x 40 Coach Head Bolt	0215-CH1240	4
3	Nyloc Nut M12	0221-NYL12	4
4	Washer Flat M12	0231-F12	4



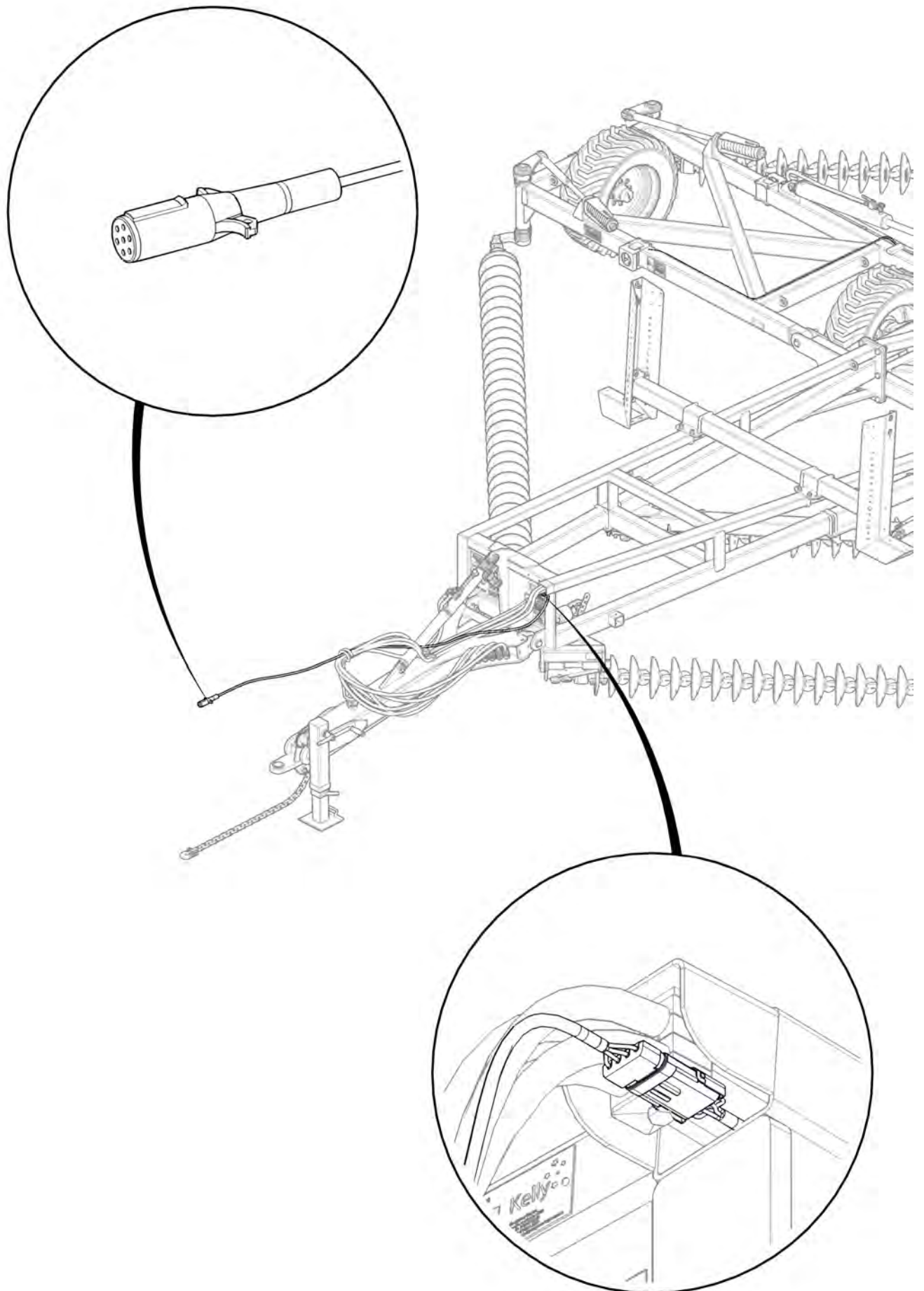

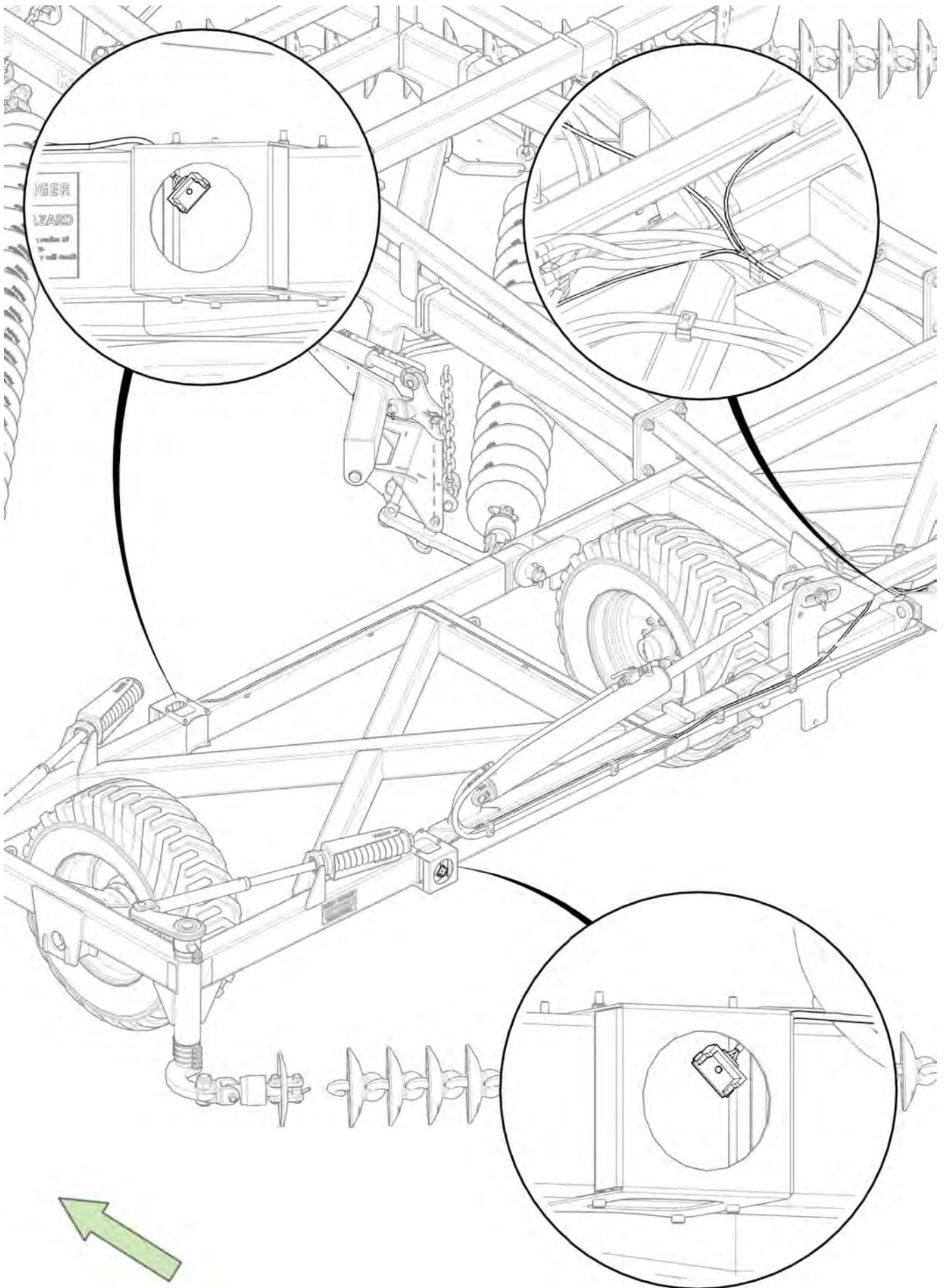

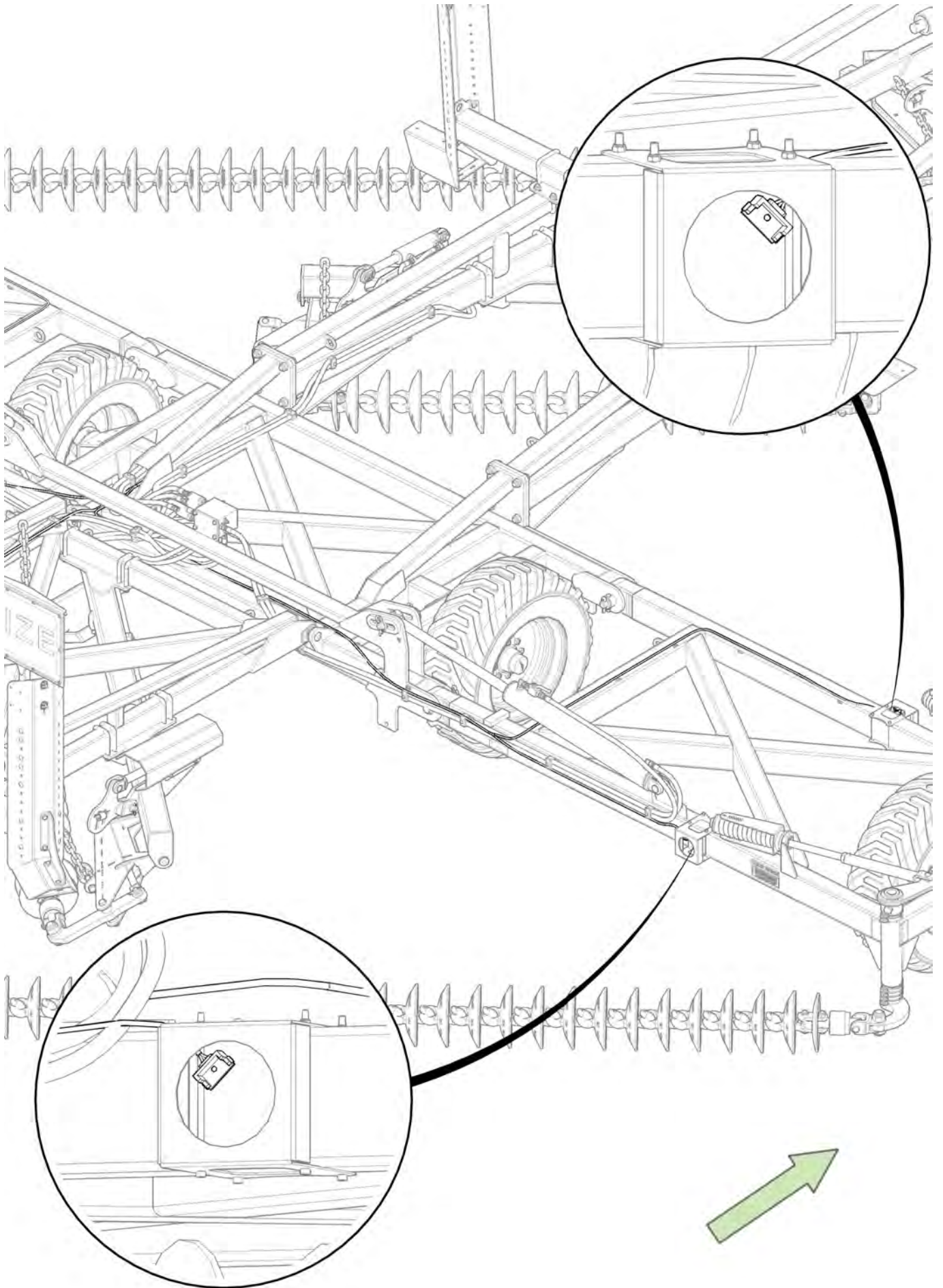

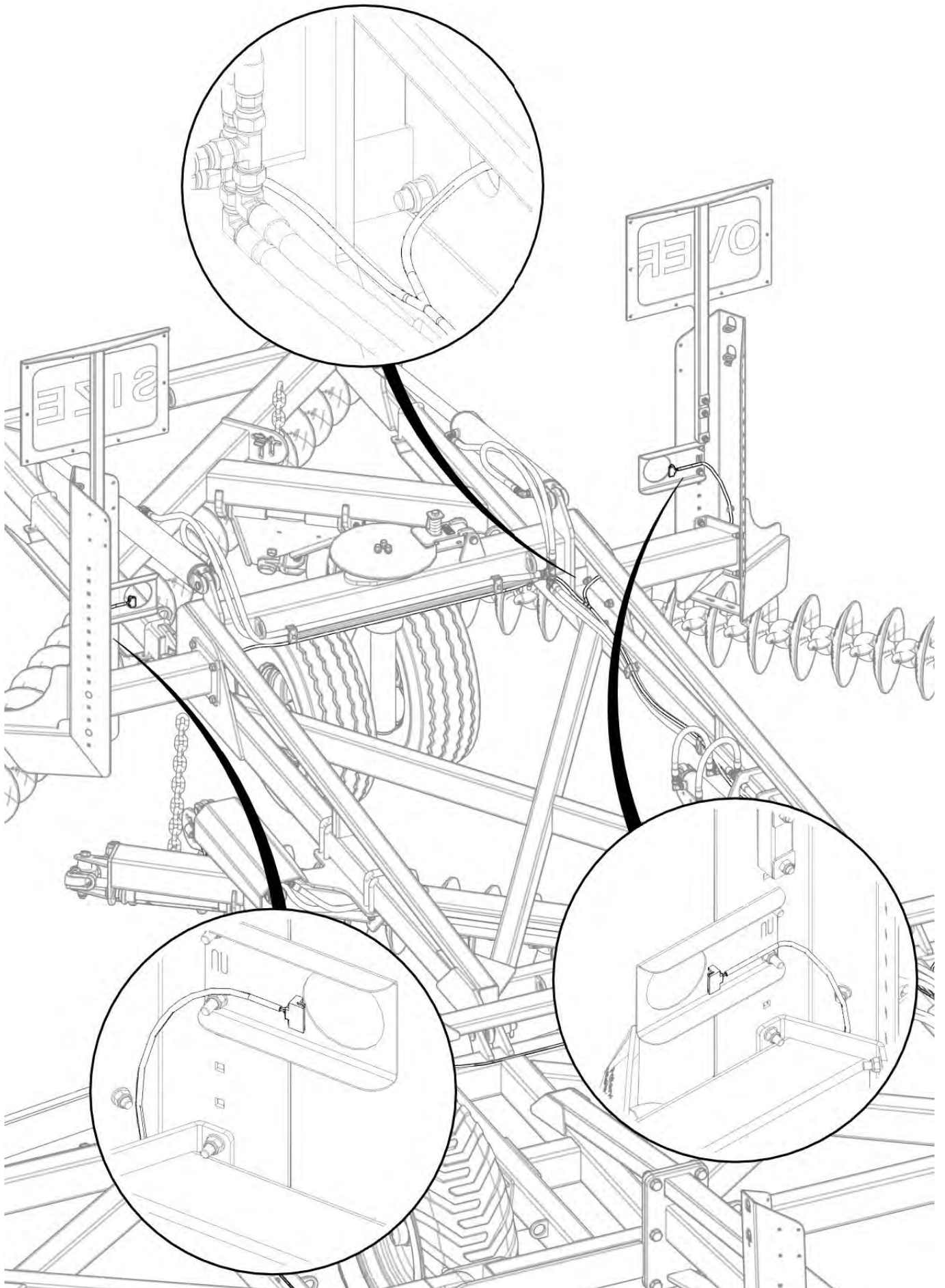

Item No.	Description	Number	Qty
1	110RM Rubber Grommet	0412-53101RG	6
2	LED Rear Indicator Lamp	0412-LED110AM	4
3	LED Stop Tail Lamp	0412-LED110RM	2

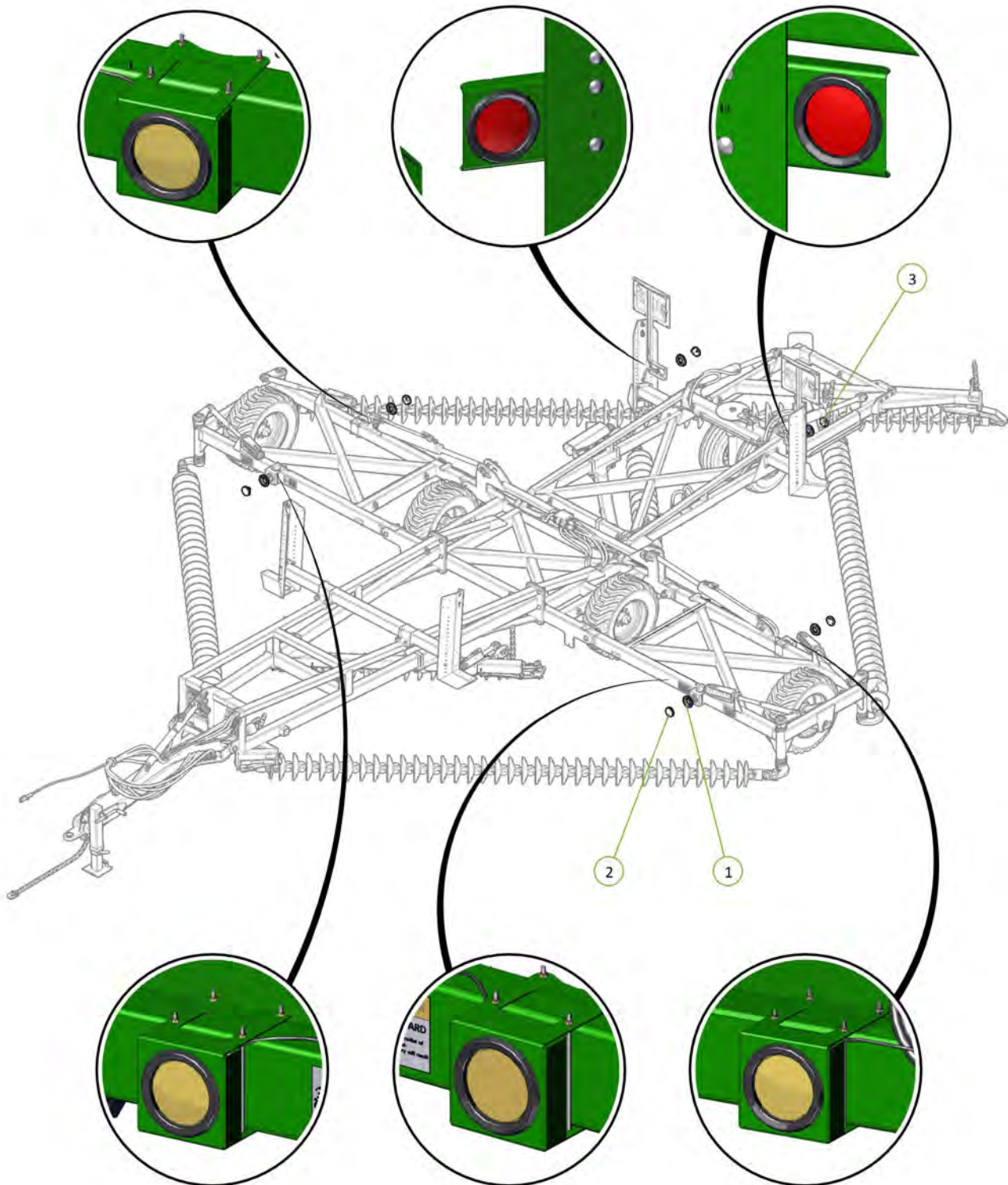

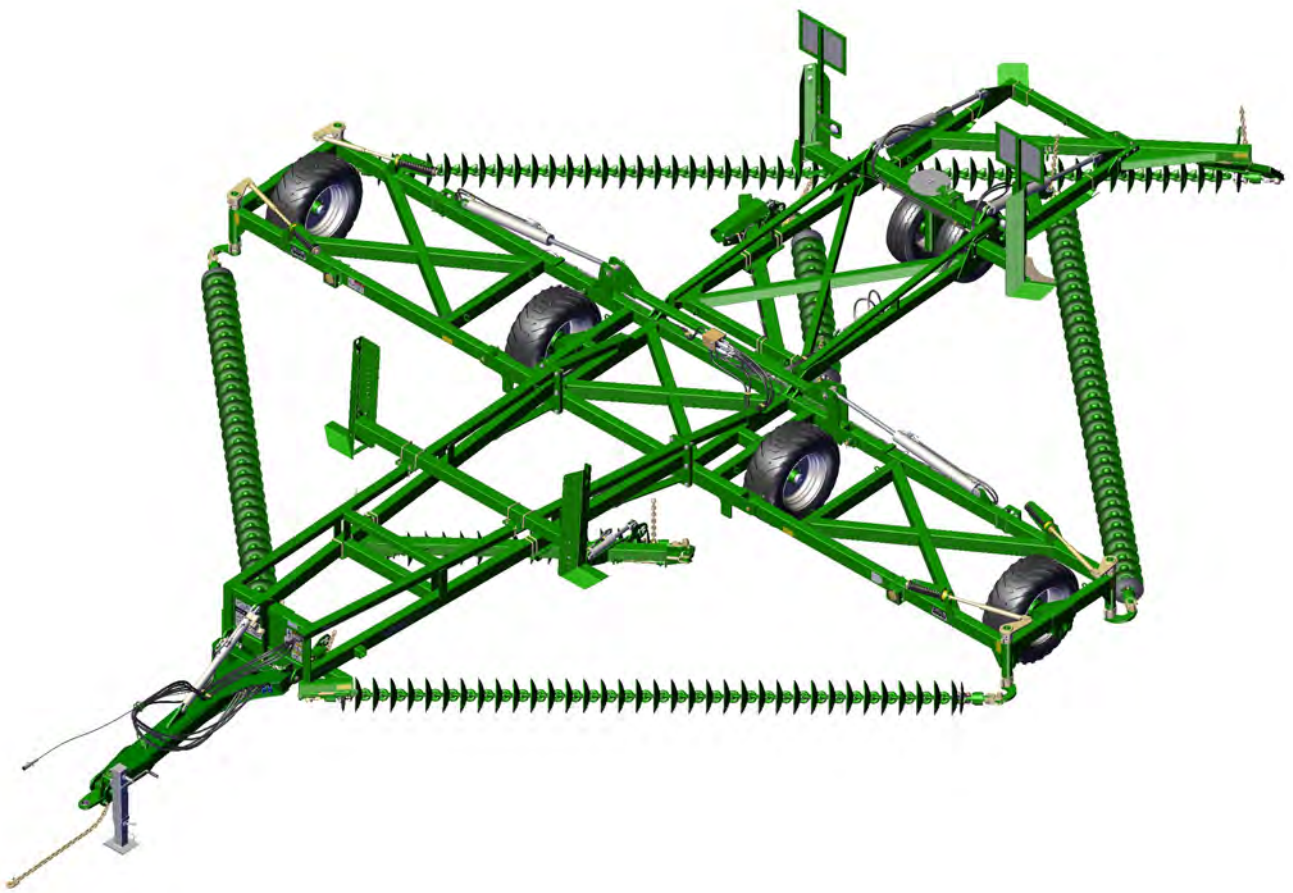

Section 5 - Chain Assembly

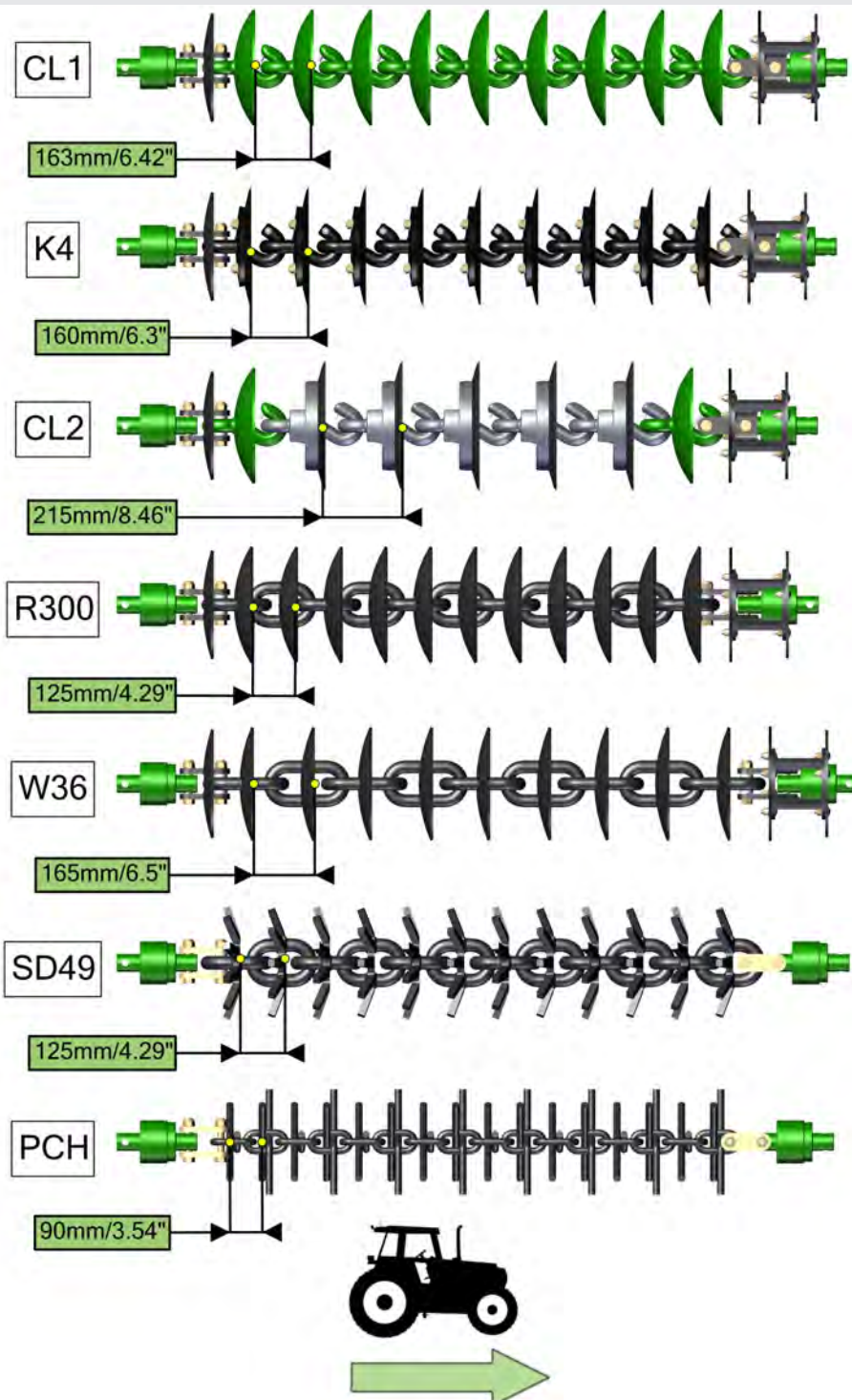

CL1 Disc Chain

Item No.	Description	Number
1	Nyloc Nut M20	0221-NYL20
2	M20 x 110 Class 10.9 ZP Short Thread Bolt	0211-20110ST
3	20mm Bolt Swivel Unit	0802-PCHB55
4	Tie Plate Disc 20mm	0802-DCTP-20
5	CL1 Disc Chain Link	0803-CL1
6	Disc Chain Spacer	0801-253755
7	Roll Pin Zinc Plated 3/8" x 3"	0262-3-8X3

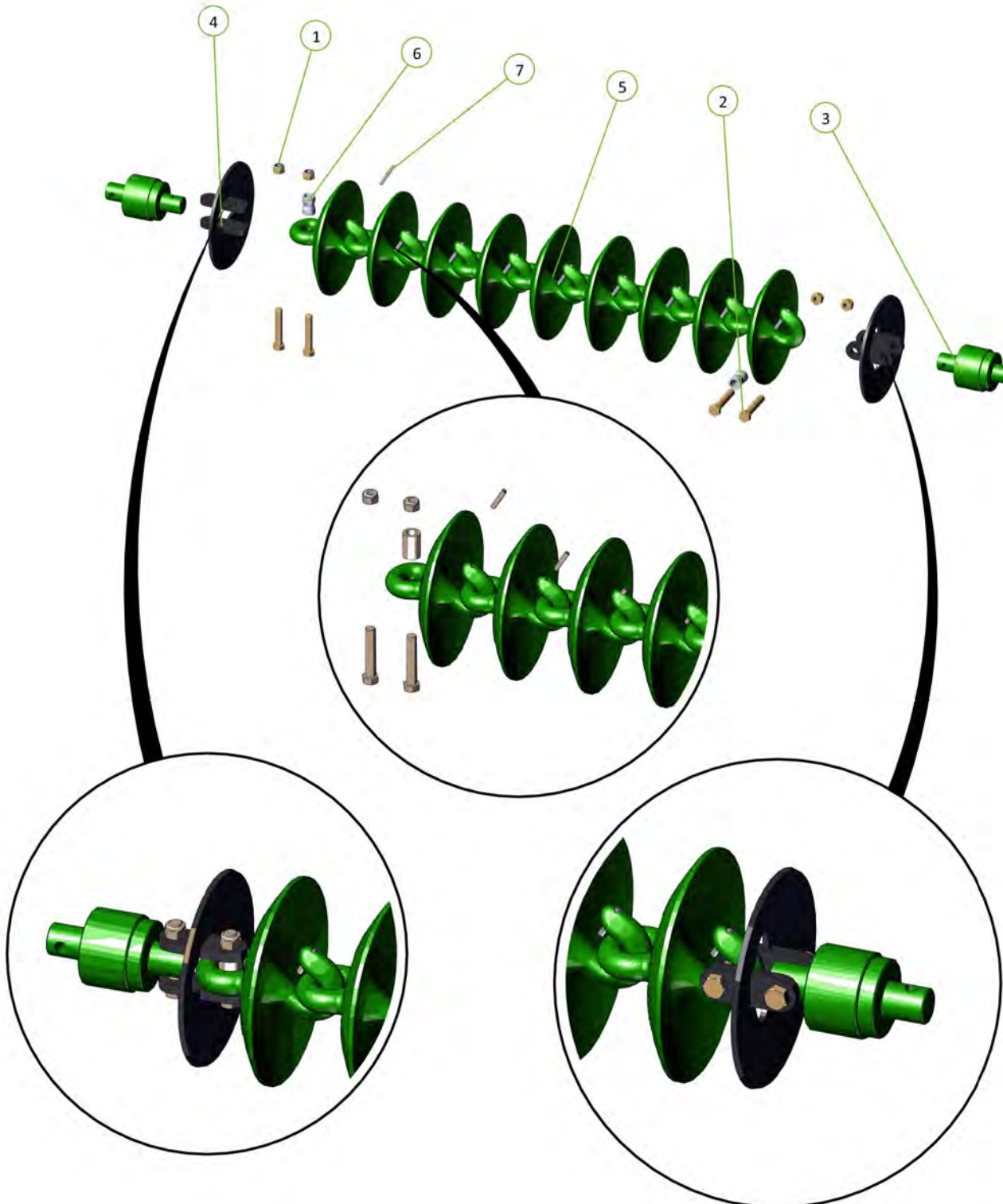

K4 Disc Chain

Item No.	Description	Number
1	Nyloc Nut M20	0221-NYL20
2	M20 x 110 Class 10.9 ZP Short Thread Bolt	0211-20110ST
3	20mm Bolt Swivel Unit	0802-PCHB55
4	Tie Plate Disc 20mm	0802-DCTP-20
5	Disc Chain Spacer	0801-253755
6	K4 Disc Assembly	0803-K4
7	M12 x 55 Class 8.8 ZP Bolt	0211-1255
8	Nyloc Nut M12	0221-NYL12

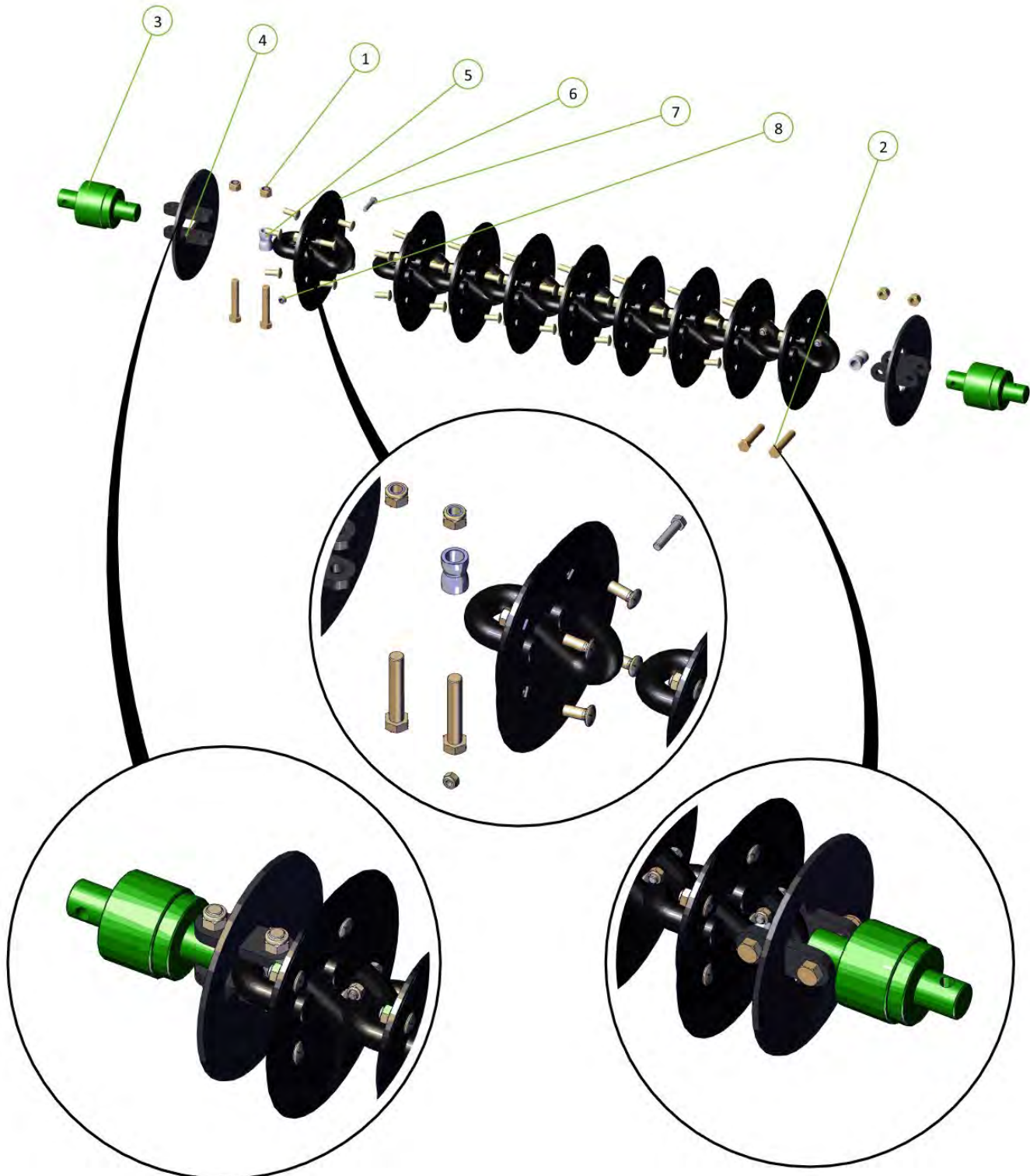

K4 Weight Assembly on Modules

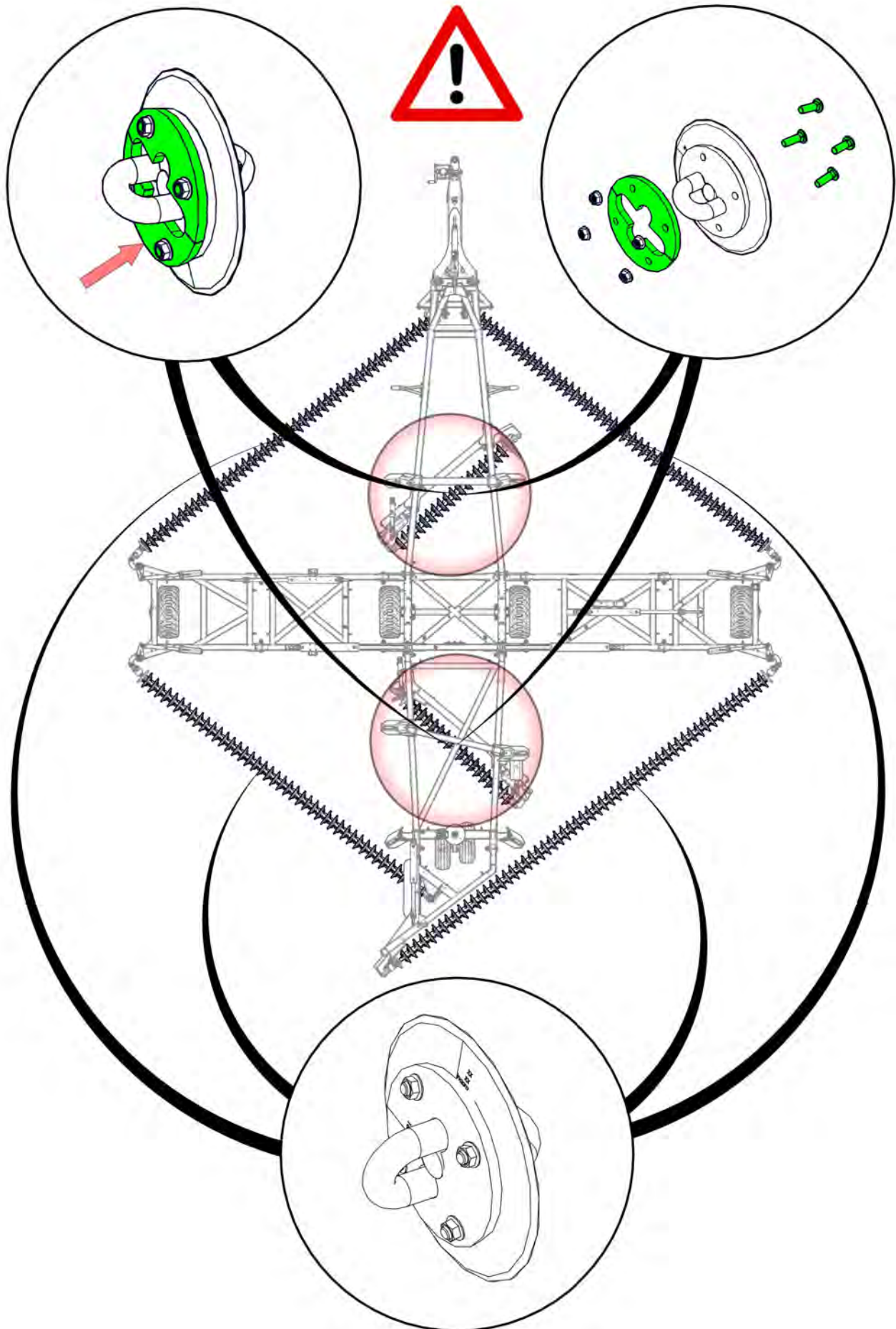

CL2 Disc Chain

Item No.	Description	Number
1	Nyloc Nut M20	0221-NYL20
2	M20 x 110 Class 10.9 ZP Short Thread Bolt	0211-20110ST
3	20mm Bolt Swivel Unit	0802-PCHB55
4	Tie Plate Disc 20mm	0802-DCTP-20
5	Roll Pin Zinc Plated 3/8" x 3"	0262-3-8X3
6	CL2-Link Assembly	0803-CL2
7	CL1 Disc Chain Link	0803-CL1
8	Disc Chain Spacer	0801-253755
9	Roll Pin Zinc Plated 3/8" x 2"	0262-3-8X2

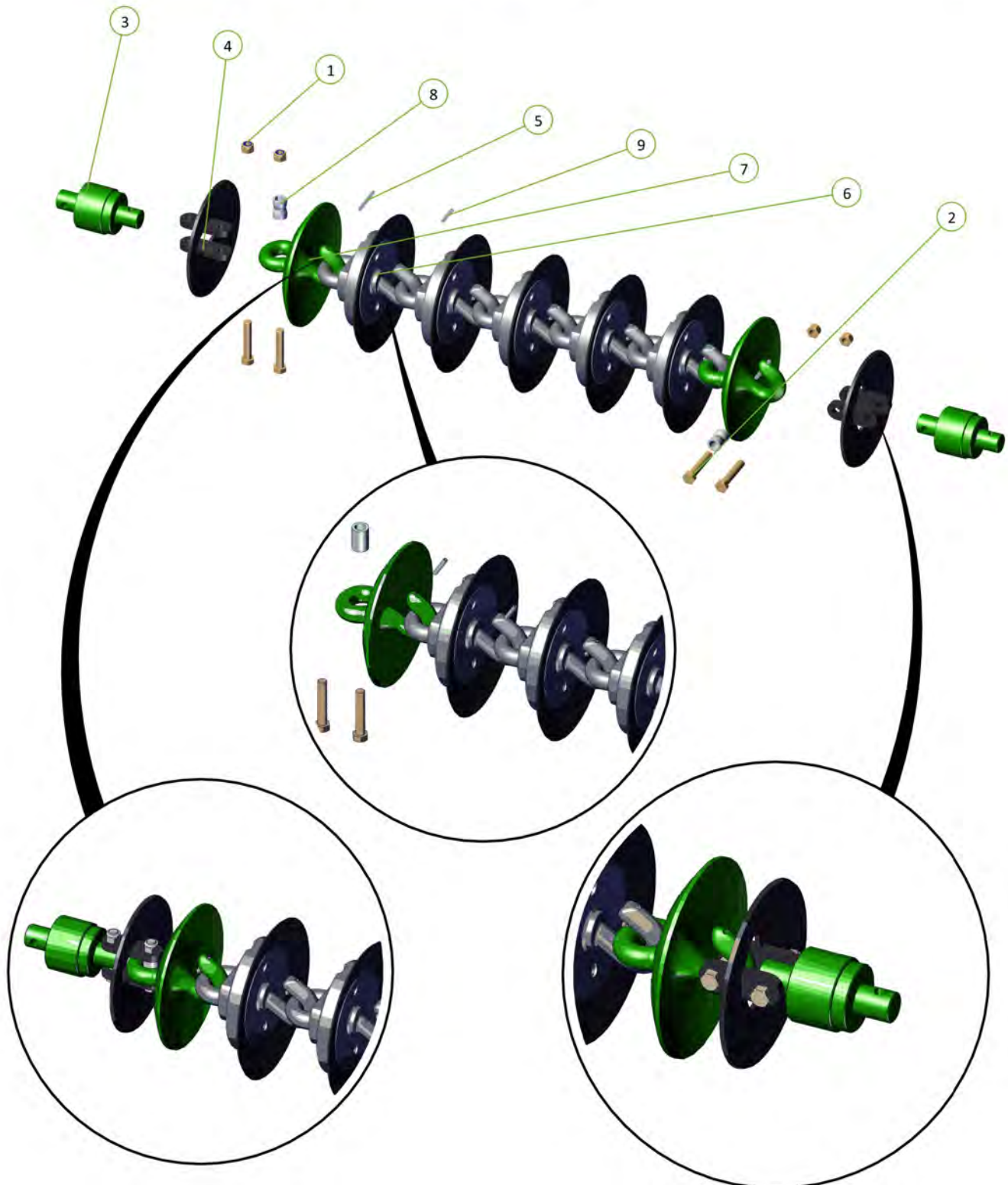
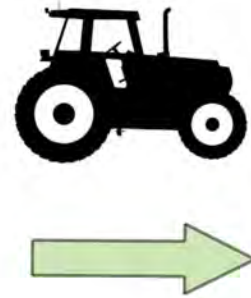

CL2 Chain Layout

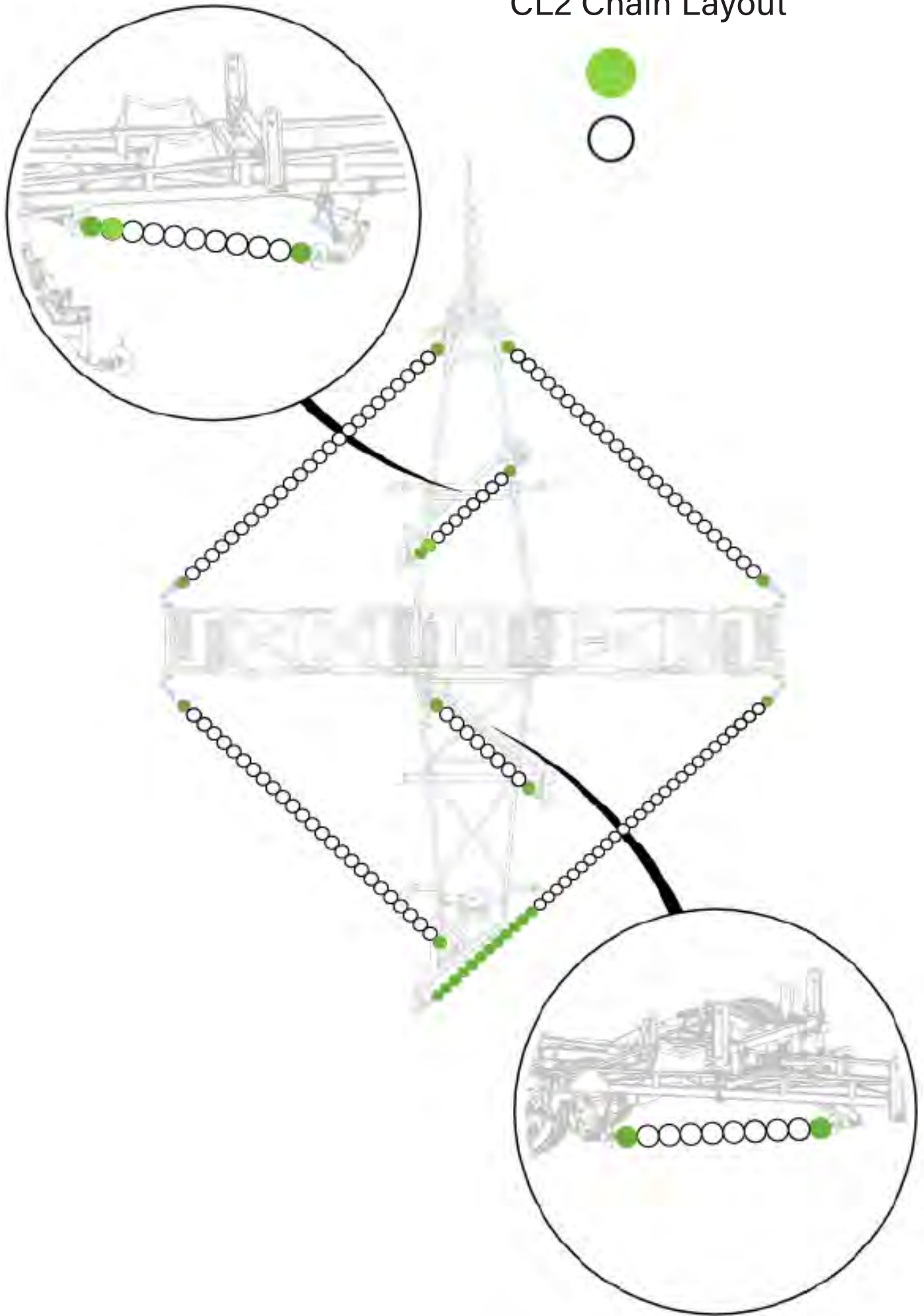

R300 Disc Chain

Item No.	Description	Number
1	Nyloc Nut M20	0221-NYL20
2	M20 x 110 Class 10.9 ZP Short Thread Bolt	0211-20110ST
3	20mm Bolt Swivel Unit	0802-PCHB55
4	Tie Plate Disc 20mm	0802-DCTP-20
5	Disc Chain Spacer	0801-253755
6	R300 Chain Link	0803-R300

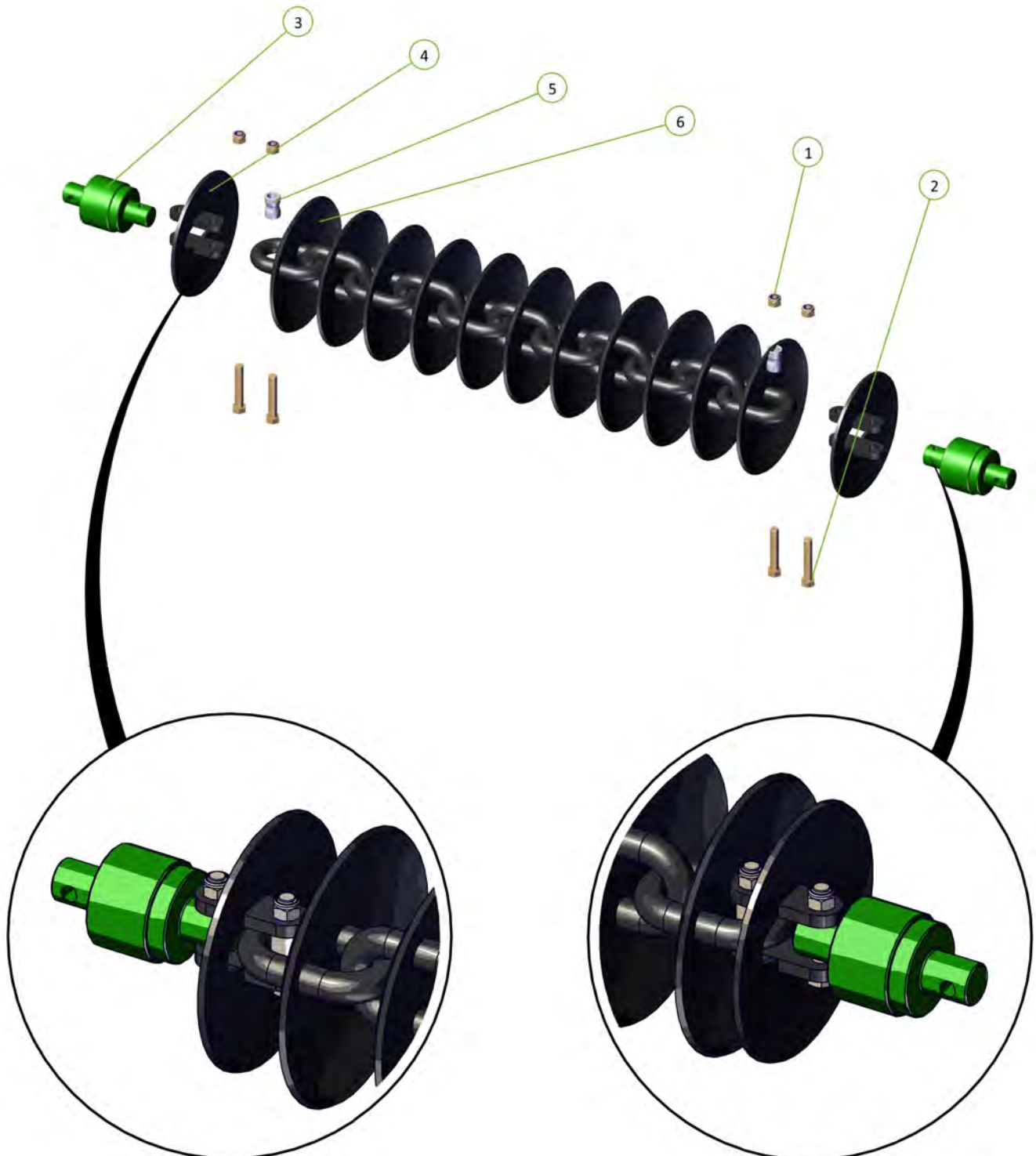

W36 Disc Chain

Item No.	Description	Number
1	Nyloc Nut M20	0221-NYL20
2	M20 x 110 Class 10.9 ZP Short Thread Bolt	0211-20110ST
3	20mm Bolt Swivel Unit	0802-PCHB55
4	Tie Plate Disc 20mm	0802-DCTP-20
5	Disc Chain Spacer	0801-253755
6	W36/25 Chain Link	0803-W36

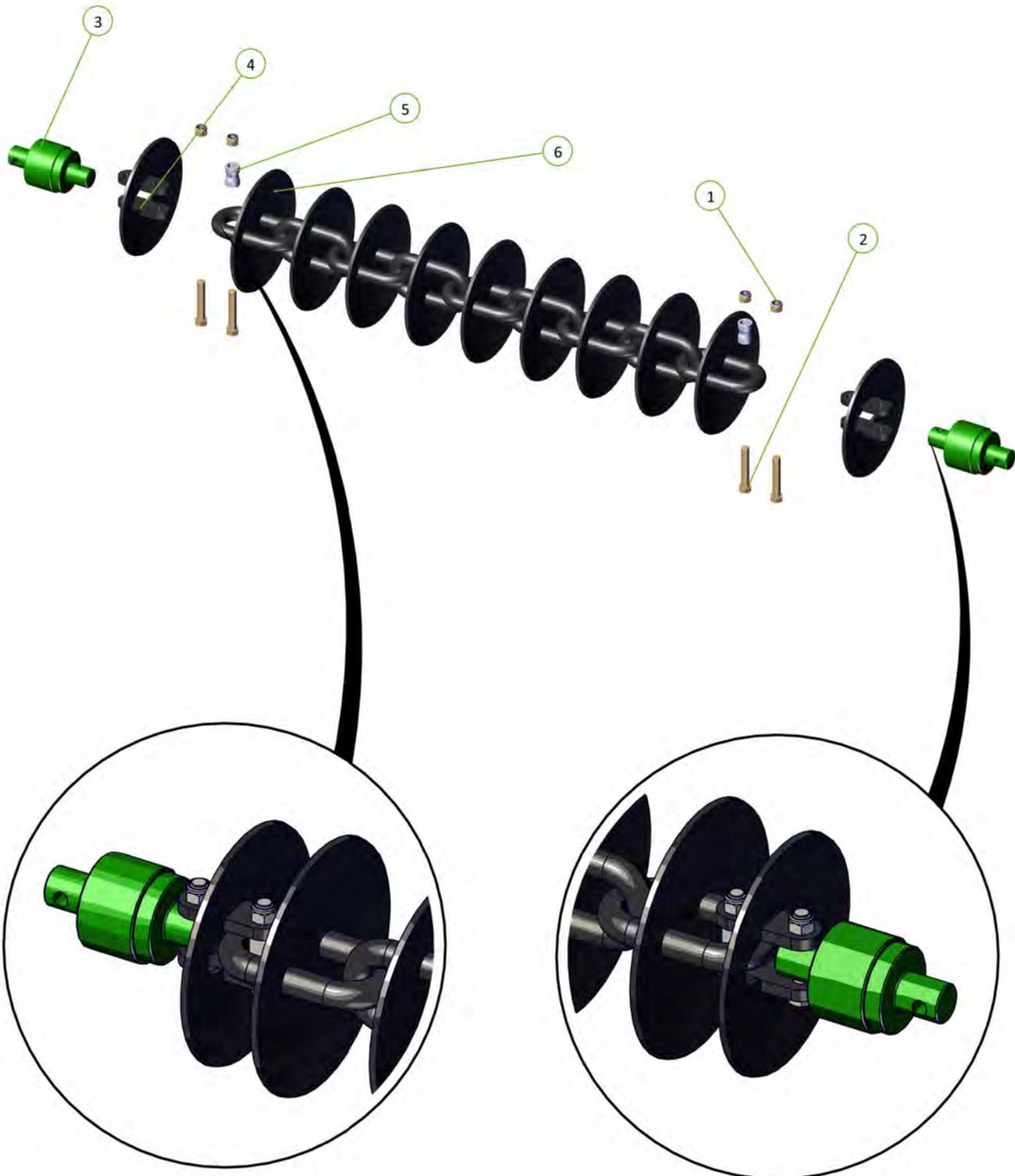
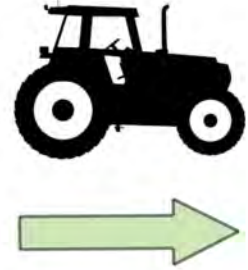

Spike Disc Chain

Item No.	Description	Number
1	Nyloc Nut M20	0221-NYL20
2	M20 x 110 Class 10.9 ZP Short Thread Bolt	0211-20110ST
3	20mm Bolt Swivel Unit	0802-PCHB55
4	Tie Plate For 20mm Bolt	0800-83.2
5	Disc Chain Spacer	0801-253755
6	10 Spike Disc Chain 49/27/5	0803-SD49

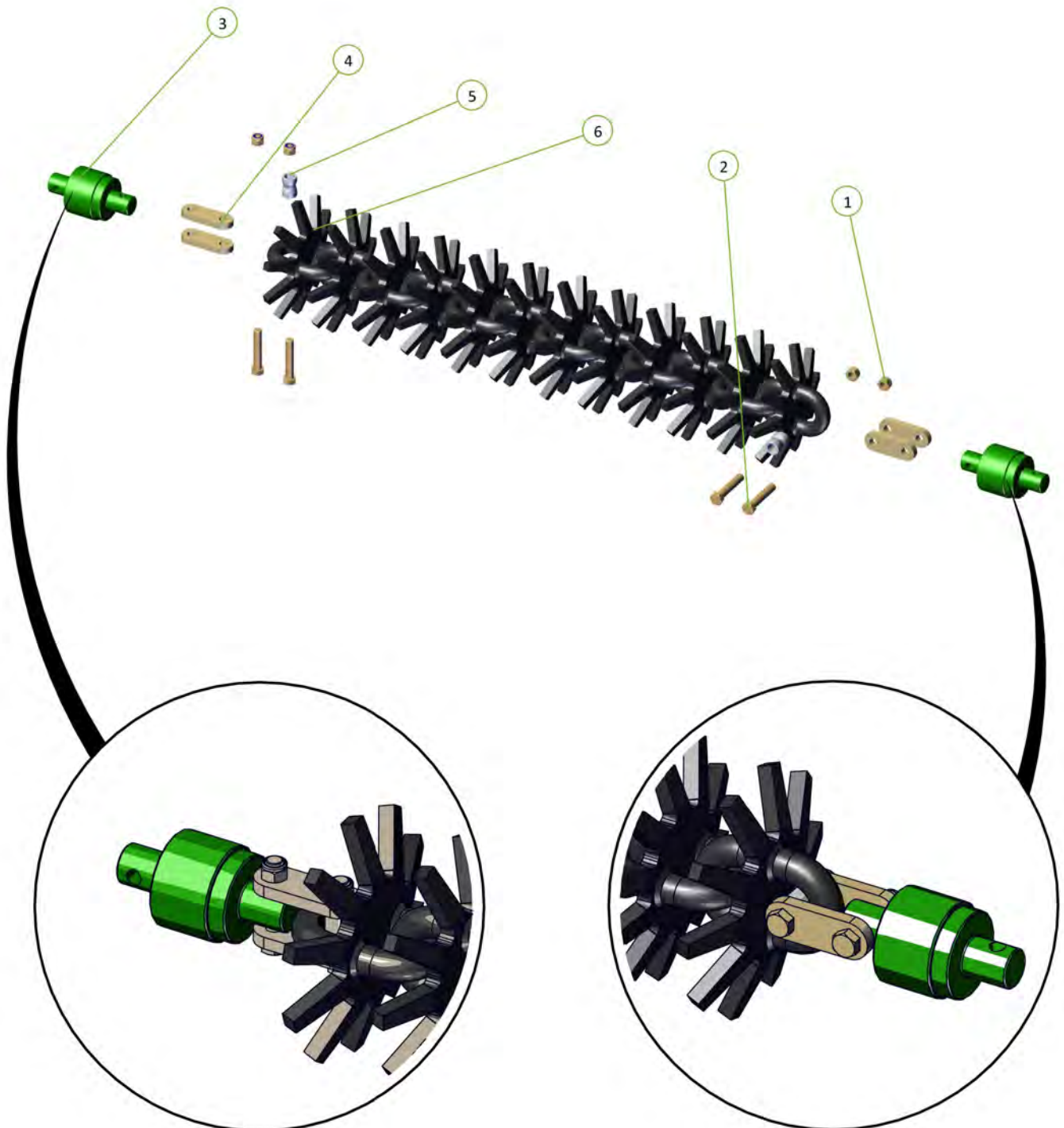
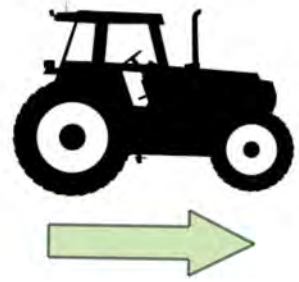

Prickle Chain

Item No.	Description	Number
1	Nyloc Nut M20	0221-NYL20
2	M20 x 110 Class 10.9 ZP Short Thread Bolt	0211-20110ST
3	20mm Bolt Swivel Unit	0802-PCHB55
4	0800-83.2	0800-83.2
5	Prickle Chain	0803-PCH

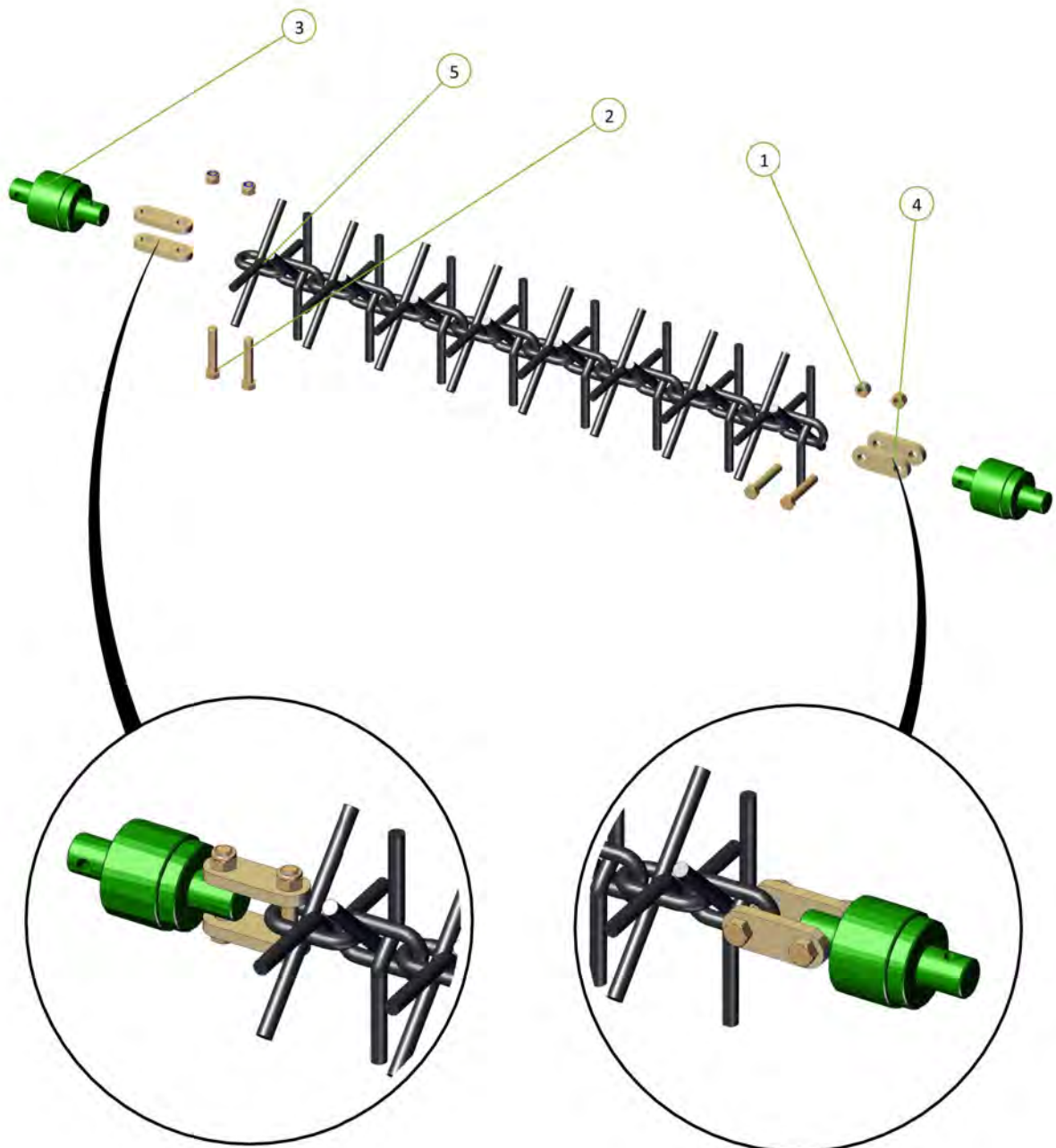
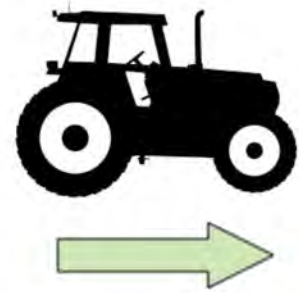



Section 6 - Specifications

Wiring Diagram

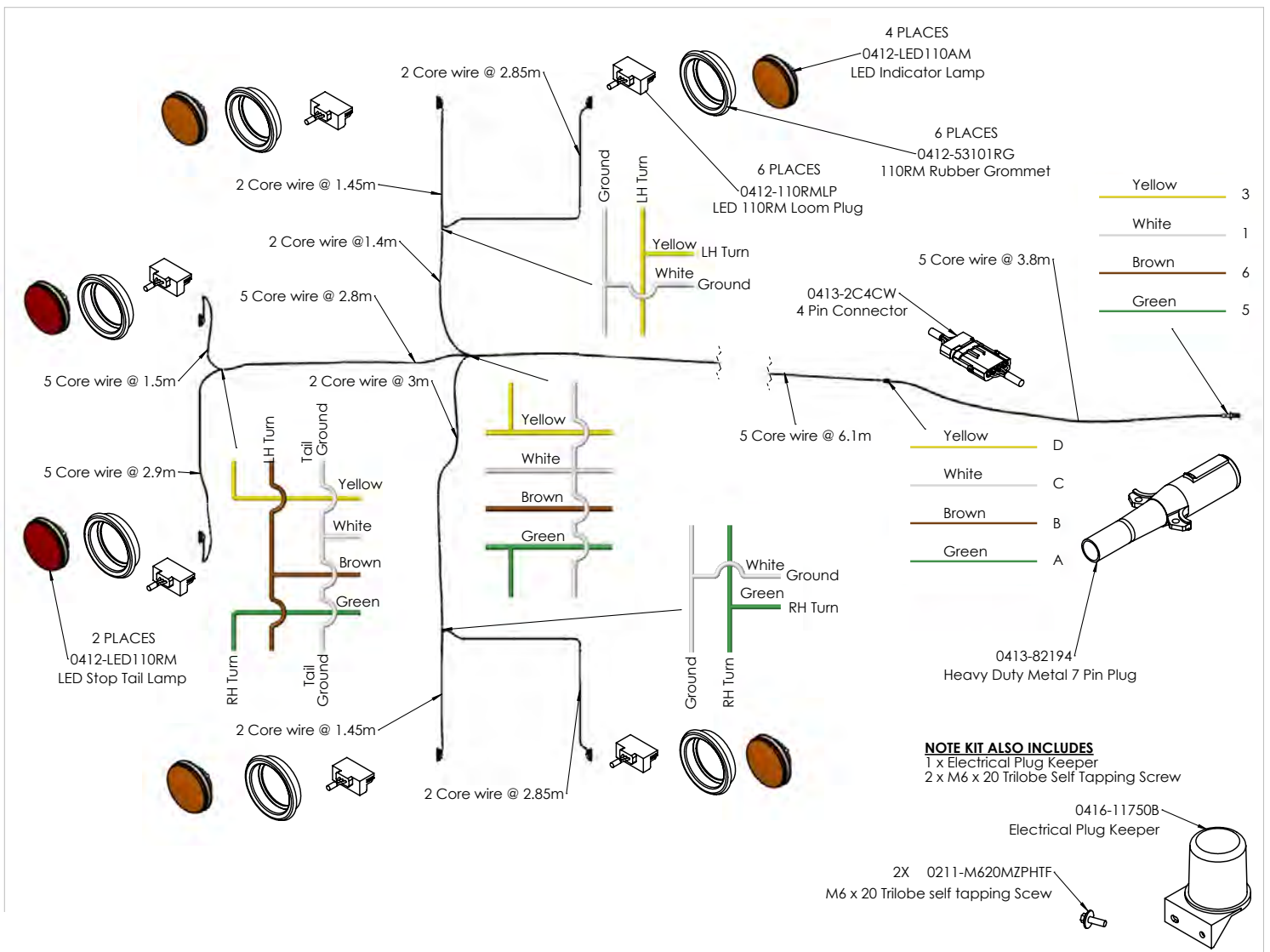

Operating speeds

Operating speeds for normal conditions	
Chain type	Speed
Prickle Chain	6-10 Mph / 10-16 kmph
Disc Mulch Chain	6-8 Mph / 10-12 kmph
Transport / towing on roads	15 Mph / 25 kmph

Tire pressure

Tire size	Ply	PSI	KPA
16.5L x 16.1	14	36	250
H40 x 14.5-19	26	60	410
11L - 15	10	44	300
15.5/80/24	16	58	400
16.5/85/24	16	55	380
550/60/22.5	16	40	280
400/55/22.5	18	50	350
12.5/80/18	14	85	590
15.0/70/18	14	71	490

Chain Harrow specifications

Model	3009
Working width	29.79'/9.0m
Transport width	11.5'/3.5m
Transport height	13'/4.0m
Transport length	40.7'/12.4m

Disc Chain lengths

Model 3009		Length	CL2	CL1	K4	W36	R300	SD49	Prickle chain
			CL2 disc chain also requires CL1 disc chain						
3009	Front right	19'/5.8m	CL2 - 25 CL1 - 2	35	36	34	46	46	64
	Front left	19'/5.8m	CL2 - 25 CL1 - 2	35	36	34	46	46	64
	Rear right	25.6'/7.8m	CL2 - 27 CL1 - 13	48	50	46	63	63	87
	Rear left	19'/5.8m	CL2 - 25 CL1 - 2	35	37	34	46	46	64
	Modules front	7.5'/2.3m	CL2 - 9 CL1 - 3	14	15	14	19	19	26
	Modules rear	6.6'/2m	CL2 - 8 CL1 - 2	12	13	12	16	16	22

For correct chain tension, chain links may need to be removed from the end of the chain as follows:

CL2 Disc Chain - unhook disc chain link/s from end of the disc chain

CL1 Disc Chain - unhook disc chain link/s from end of the disc chain

K4 Disc Chain - unhook disc chain link/s from end of the disc chain

Spiked Disc Chain - cut a disc chain link from the end of the disc chain

R300 Disc Chain - cut a disc chain link from the end of the disc chain

W36 Disc Chain - cut a disc chain link from the end of the disc chain

Prickle Chain - cut a prickle chain link from the end of the prickle chain





Section 7 - Operation

Basic Operation

Unfolding:

1. Walk around and inspect the machine.
 - a. Check that chains are not hooked on framework.
 - b. Check swivel bolts are in place and not broken.
 - c. Check that height adjusting chains have not fallen out of their slotted plates during transport.
 - d. Ensure front lift cylinder depth stops are fully engaged on cylinder shaft.
2. Lower front A frame to working height.
3. Unfold wings holding the hydraulic lever until both the main center cylinder pins have centered in their slots. (If chain pulls tight during unfold, stop and inspect if chain is hooked)
4. Lower rear tail by holding hydraulic lever until tail and modules are completely lowered to working position.
5. Walk around and check that all chain links are straight and that working height of all swivels is correct for field conditions. Adjust if necessary.
6. Move off with all chains in working position. If necessary it is acceptable to raise front A pull to transport height. This will lift the front chains off the ground and reduce the load on the tractor. Lower the front A pull once moving satisfactorily.

Folding:

1. Lower the front A frame to working height. (This is important to ensure that all chains locate correctly in their transport rests).
2. Raise the Rear Tail and modules by holding the hydraulic lever until they come to a complete stop.
3. Fold the wings. They should move as follows; main center cylinders will retract, one or both, until the wings stand vertically. The left outer wing then the right outer wing will fold down.
4. Raise front A frame to transport height.
5. Walk around and check that chains have located correctly in transport rests.
(3009 only, close wing transport lock valves).

Setting for correct chain tension

Wings:

Use the spanner supplied. Loosen the lock nut adjacent to the tensioner assembly body. Turn the tension bolt clockwise to compress the coil spring. Correct tension is achieved when spring retains its set length when operator rolls the chain fore and aft on the ground. Retighten the lock nut.

Spring Compression Length:

Compress spring to the end of the indicator as shown, 13"/330mm

When less than 4"/100mm of thread remains visible on the adjustor bolt then a link must be removed from the chain.

Modules:

1. Loosen the lock nut on the module tension rod.
2. For correct chain tension, tighten the adjusting nut clockwise until the outer face of the spring retaining washer is flush with the face of the tension body. (Spring length of 330mm)
3. If more than 230mm (9") of the module tension rod extends past the face of the tension body, then remove one link from the chain set to maintain correct chain tension.
4. Retighten the Lock nut.

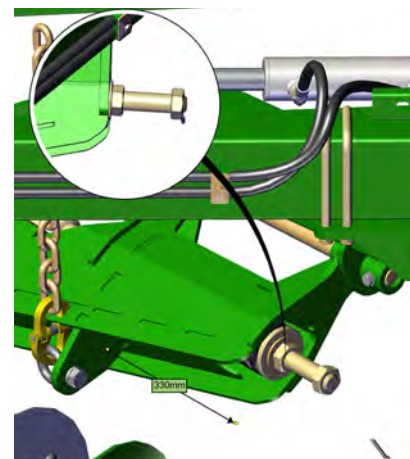
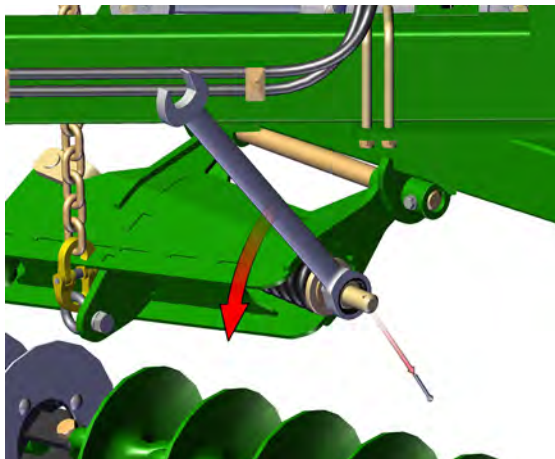
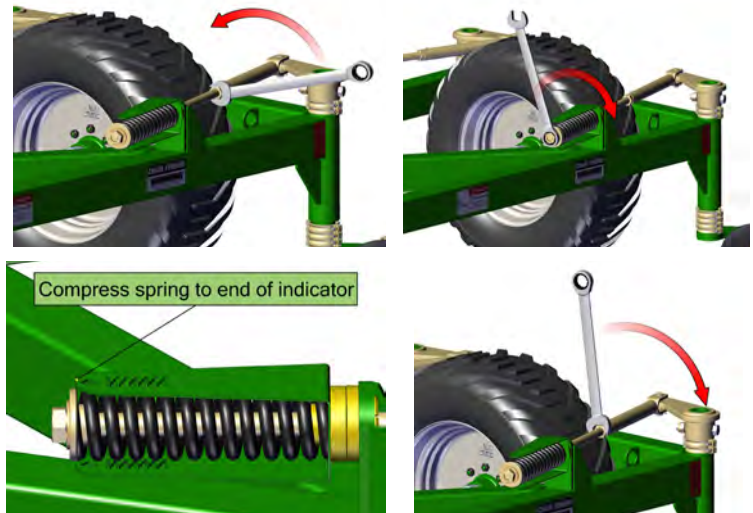
**Importance of chain tension****Operational**

It is imperative that the correct adjustment be maintained. Only through correct adjustment can a smooth and level finish be achieved in field working.

Loose chains lead to :

- Uneven performance across the width of the machine
- Uneven weed control
- Unsatisfactory incorporation
- Ineffective levelling
- Accelerated or premature chain wear
- Chains failing to engage with transport locators when folded
- Machine damage when folding or unfolding
- Uneven field surface with ridges and furrows being created. The leading 1/3rd of a loose chain is much more aggressive than the trailing 1/3rd and the center. This will mean that middle of the machine's front pair of chains will aggressively move soil outwards. The machine's rear pair of chains, if loose, have their aggressive 1/3rd near the wing extremity. It follows then that as the front discs push soil outwards, the least aggressive portion of the rear chain follows them and does not balance the soil movement. This is exacerbated at the wings, effectively creating a broad ridge about halfway out each wing. It won't be evident in one pass, but is possible if care is not taken over time.

A correctly adjusted machine will not cause this phenomenon.

Settings for correct working height

To adjust the swivel height at the wings, relocate one pair of the spacers either above or below the fixed mounting tube.

Adjustment

1	Loosen chain tension completely
2	Undo 2 x M10 bolts from corresponding spacer set and take the two halves off of the drop leg tube
3	Replace it in the selected position after raising or lowering the drop leg
4	Reinstall the M10 bolts and re-tension the chain

It is possible to install all spacers either above or below the mounting tube giving a maximum of 4" (100mm) of adjustment.

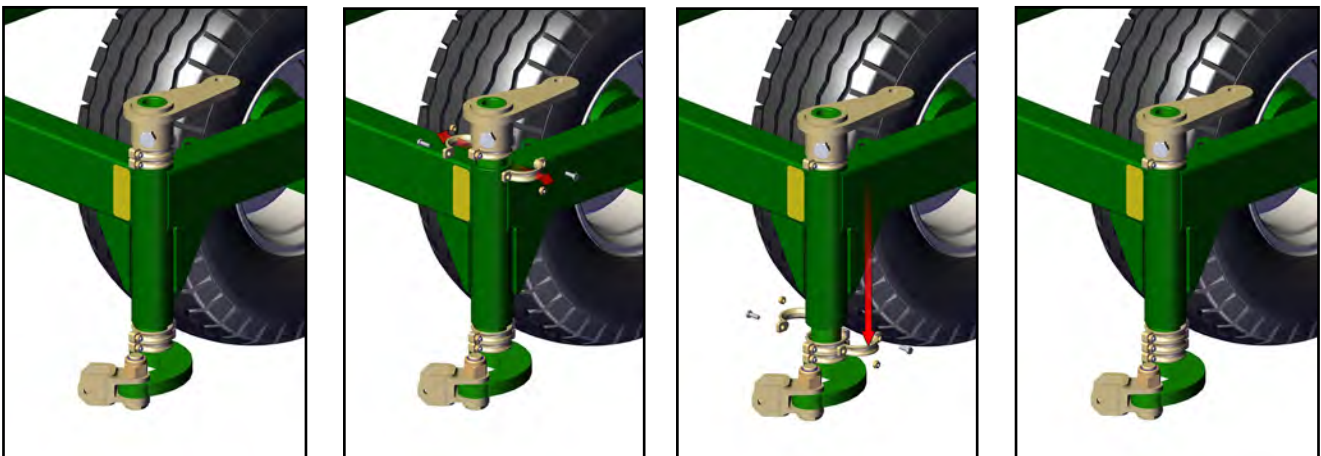



Phone +61 8 8667 2253
Email sales@kellytillage.com
kellytillage.com

Booleroo (Head Office)
684 Kelly Road,
Booleroo Centre SA 5482

Adelaide Office
28 Greenhill Road,
Wayville SA 5034

