

KELLY

Better Tillage. Better Tomorrow.

Assembly Manual

KELLY TILLAGE SYSTEM 40

KEASM-N-01012023

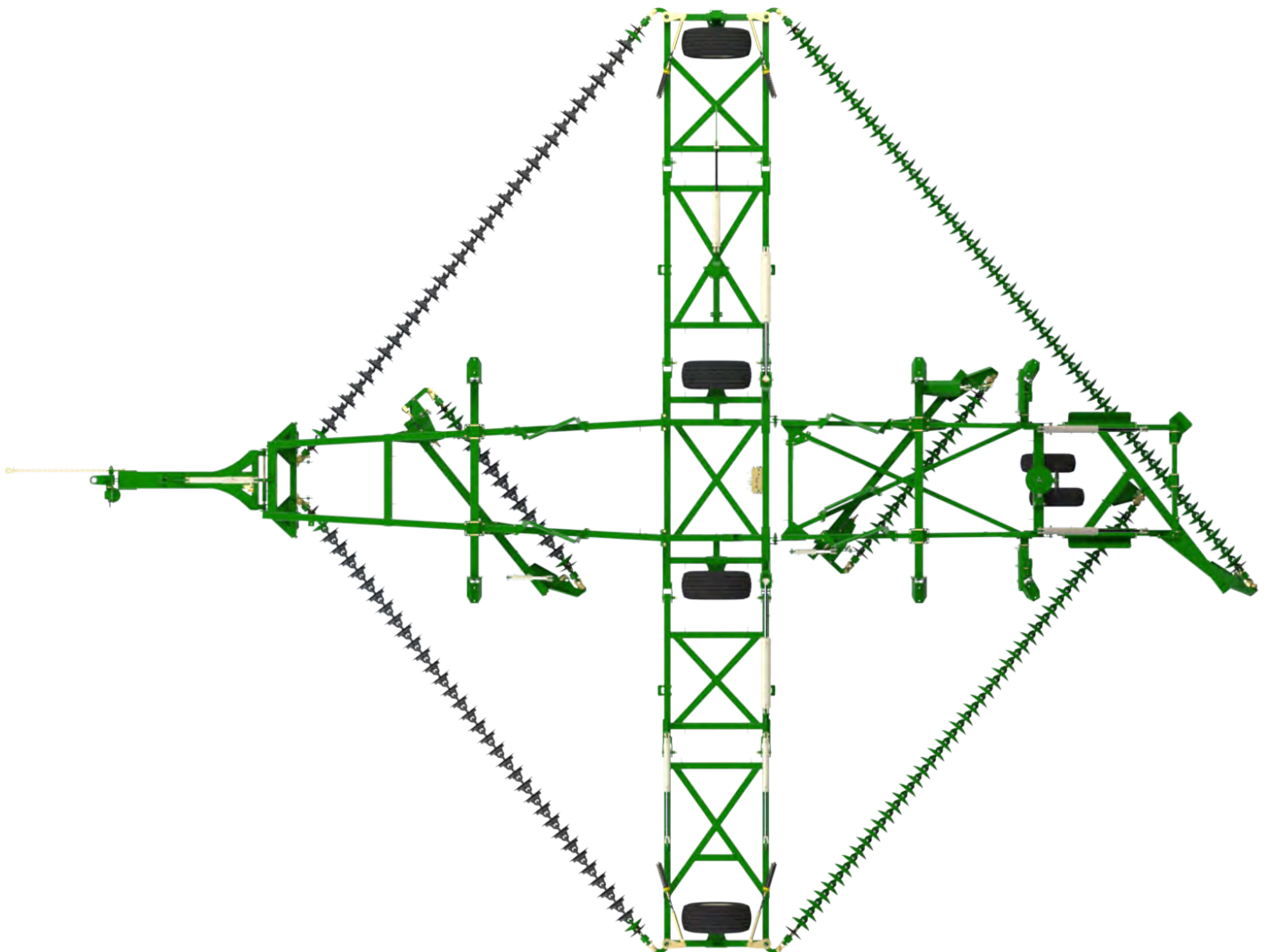

SERIAL NUMBER:

KELLY

Phone +61 8 8667 2253
Email sales@kellytillage.com
kellytillage.com

Booleroo (Head Office)
684 Kelly Road,
Booleroo Centre SA 5482

Adelaide Office
28 Greenhill Road,
Wayville SA 5034





Thank you for choosing a KELLY product.

We trust that you find the following manual clear and easy to follow. If you should require additional customer support or assistance, please do not hesitate to contact us.

Spare parts can be purchased, as required, through your local dealer or by contacting KELLY directly.

The KELLY team values your feedback. Should you have any difficulties that you wish to raise, suggestions for improvement or modifications that you feel would enhance our products we look forward to hearing from you.

Contact Us

Australia

Booleroo (Head Office)

684 Kelly Road,
Booleroo Centre SA 5482

+61 8 8667 2253

Monday - Friday
8am - 4pm ACDT

Adelaide Office

28 Greenhill Road,
Wayville SA 5034

+61 8 8667 2253

Monday - Friday
8am - 4pm ACDT

Global Locations

Eastern Canada

Leading Edge Equipment
www.leadingedgeequipment.ca

1-519-421-3223

Monday - Friday
8am - 4pm EST

Western Canada

Adair Sales & Marketing Co Inc
www.adairreps.com

1-306-773-0996

Monday - Friday
8am - 5pm CST

United States

Hood & Company

+1 417-865-2100

Monday - Friday
8am - 4pm CST

Europe

kellytillage.com

+61 8 8667 2253

Monday - Friday
8am - 4pm ACDT

Argentina

Giorgi Sa Maquinarias Agrícolas
www.giorgi.com.ar

+54 3464 493512

Monday - Friday
8am - 5pm ART

South Africa

Desmond Whitfield CC

+27 82 567 8245

Monday - Friday
8am - 4pm SAST

Contents

Section 1 - Unpacking	5
Section 2 - Assembly	7
Section 3 - Decal Placement	117
Section 4 - Light Kit	139
Section 5 - Chain Assembly	147
Section 6 - Specifications	157
Section 7 - Operation	159

Legend



This symbol indicates which bag the relevant fasteners are in.



This symbol indicates which bag the relevant hydraulics are in.

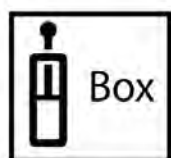

This symbol indicates the hydraulics are in a box.



This symbol indicates which way the machine is travelling.

Bolt Torque Settings

Bolt Type	Wheel nut				U Bolt			Grade 8.8 Bolt					Grade 10.9 Bolt		Grade 8 Bolt
Bolt Size	M18	M20	1/2"	9/16"	M10	M12	M16	M10	M12	M16	M20	M24	M20	M24	1" UNF
Ft lb	255	265	90	100	22	36	55	32	48	140	190	270	300	350	849
Nm	345	360	125	140	30	50	75	44	65	190	260	370	406	475	1151

[1] When fitting a wheel & tire to a hub, tighten the wheel nuts in a star pattern to the correct tension. To achieve this choose a wheel nut & tighten, then proceed to the opposite side of the hub to the next wheel nut & tighten & so on until all wheel nuts are tight. Then repeat the procedure to check that all nuts are tight. Do not use impact tools to tighten wheel nuts. For a guide to the correct tension of the wheel nuts please use the appropriate tension for your size wheel nuts from the Bolt Torque Settings table.

Torque values are for dry threads and surfaces however it is permissible to apply a small amount of anti corrosive oil to the threads.

Verification and recording of the prescribed torque settings in the table above is the responsibility of the assembler and it shall be documented in accordance with their approved Quality Assurance system

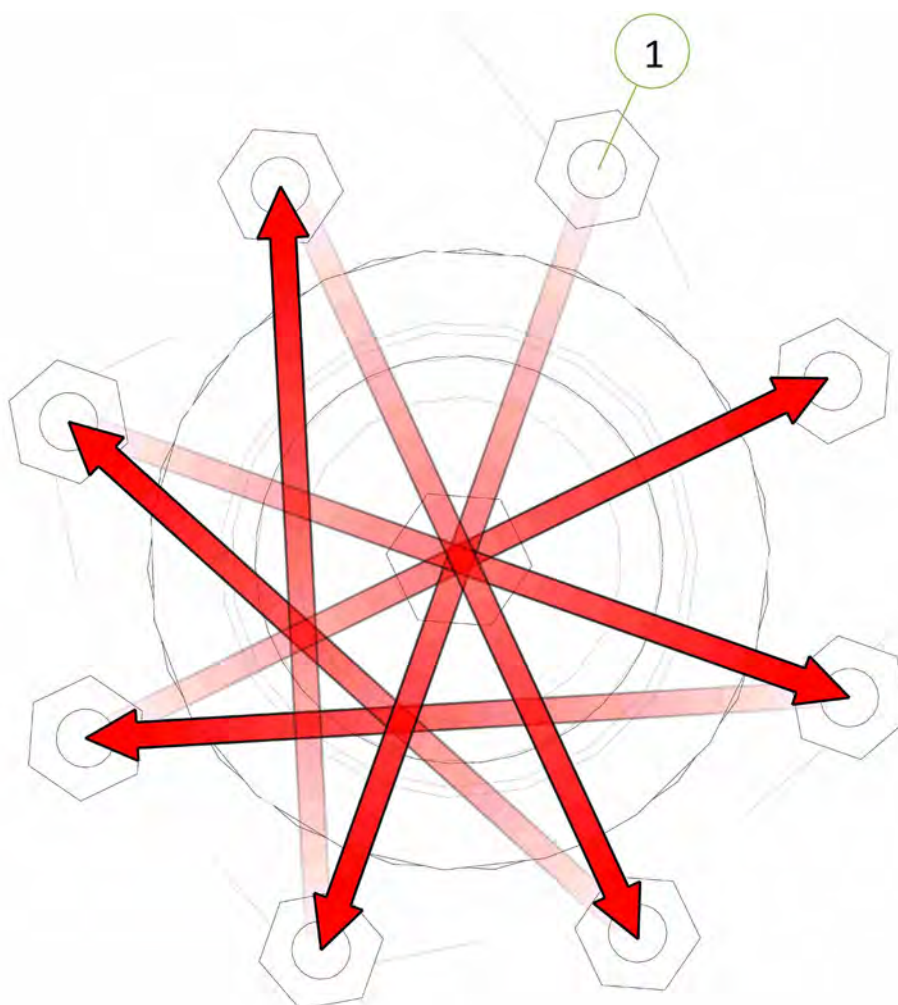



Section 1 - Unpacking

We recommend the use of suitable lifting equipment with a lifting capacity of at least 4 tones.



Before unloading any loads please inspect exterior for damage.



CAUTION

Take care when opening doors as load may have shifted or restraints may have broken.

- Remove boxes from doorway of container one at a time using a forklift truck. Each box weighs approximately (5512 lbs / 2500kg)
- Check strapping on each bundle before attempting to remove
- Attach chains to the packing frame using shackles and using suitable equipment (eg. forklift or tractor) drag framework bundles out of container. To move bundles away from front of container lift from side with forklift. Do not lift under angle iron frame, lift only under centre frame. Each bundle weighs approximately 7000 lb (3200 kg).

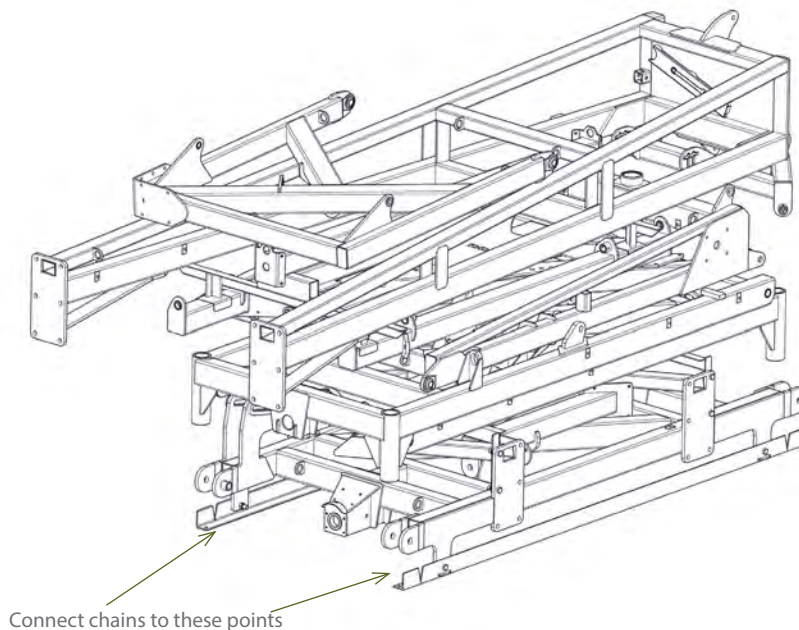

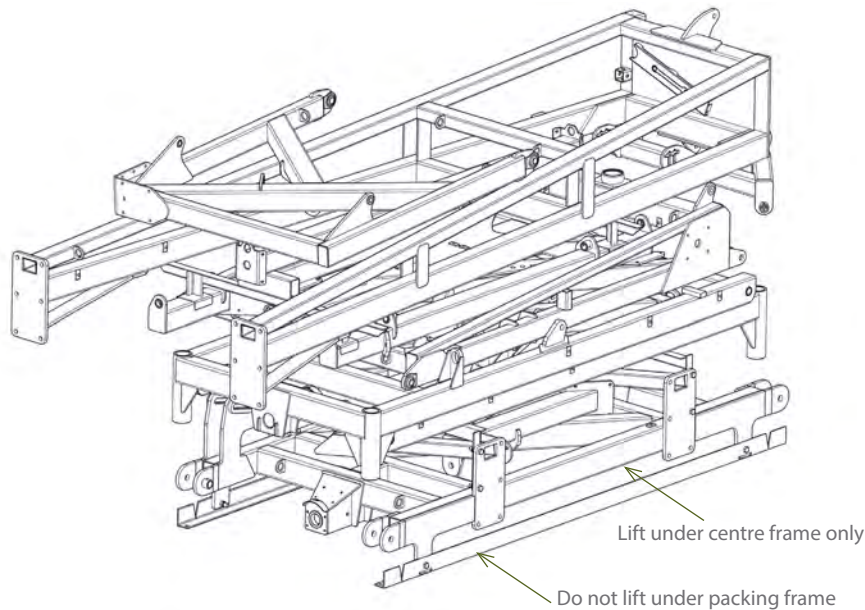

CAUTION

Before cutting straps attach slings or chains and take the weight of the frames to avoid them slipping or falling and causing injury.



CAUTION

Wear eye and hand protection when cutting straps. Sharp edges are exposed as straps separate and may cause injury.



CAUTION

To avoid falling or moving components, before cutting straps attach slings or chains to individual pieces and only cut the straps holding the piece to be lifted.

- Remove boxes from rear of container one at a time using a forklift truck. Each box weighs approximately 5512 lbs (2500 kg)
- Cut straps holding bundles and separate parts and place in assembly area
- Once all parts have been identified, the machine is ready for assembly
- Identify parts for each machine by serial no. or description and separate. Open parts box and check that all parts are accounted for against checklist
- Read assembly instructions before proceeding.

KELLY

Section 2 - Assembly

Item No.	Description	Number	Qty
1	40' Centre Frame	0840-01	1
2	2.75"R 6 Tonne 8 on 8" PCD Hub & Stub Complete	0733-SH27596880	2
3	M20 x 170 grade 8.8 ZP Bolt	0211-20170	2
4	Nyloc Nut M20	0221-NYL20	2

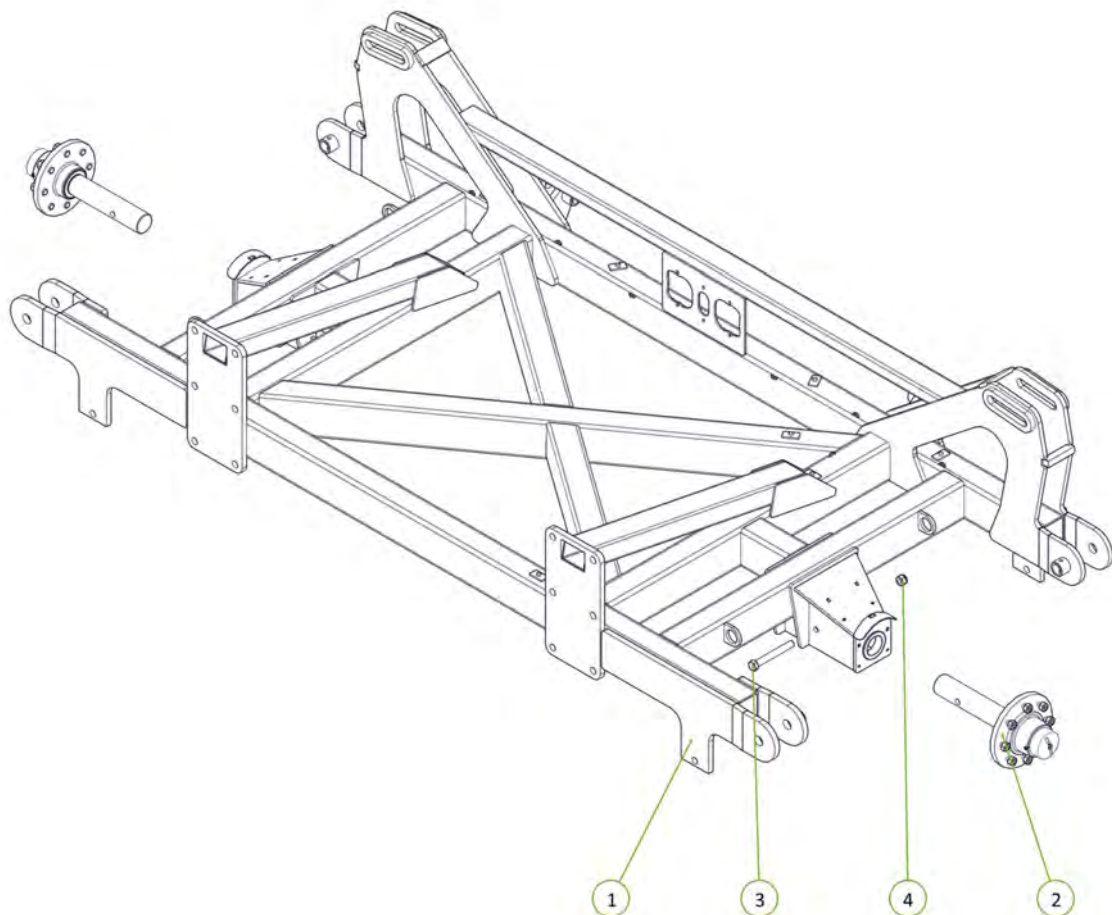
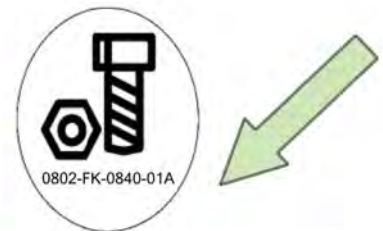

Item No.	Description	Number	Qty
1	40' LH Inner Wing Frame	0840-05	1
2	PCH Wing Pivot Pin	0801-10-08-235	2
3	35 ID x 50mm DX Bush	0113-MB3550DX	4
4	Grease Nipple 1/8" BSP 45 Deg	0181-GN1-845	2
5	Cotter Pin M13 x 63	0261-PINC1363	2
6	M12 x 80 Class 8.8 ZP Bolt	0211-1280	2
7	Nyloc Nut M12	0221-NYL12	2

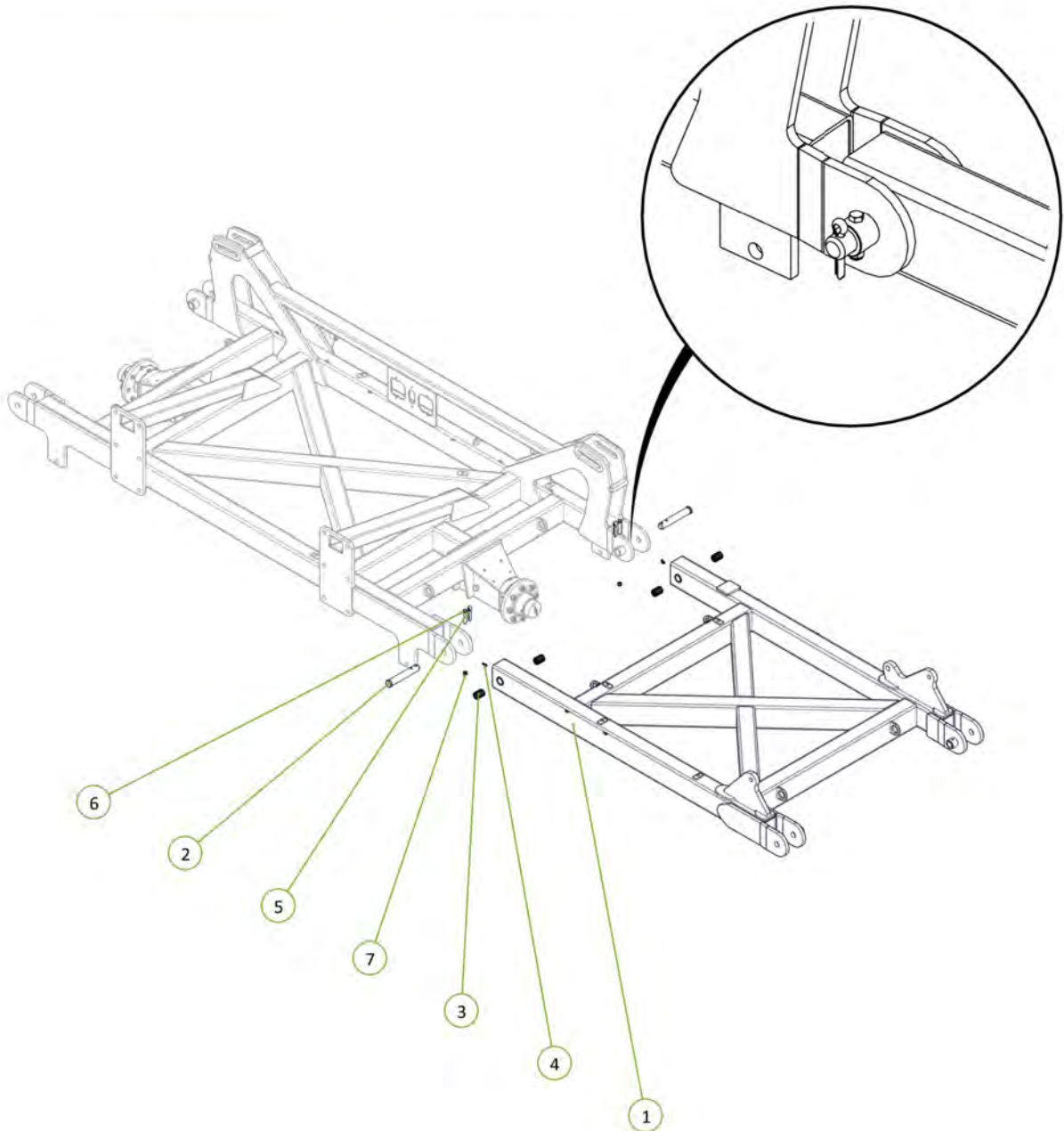

Item No.	Description	Number	Qty
1	40' LH Outer Wing Frame	0840-07	1
2	35 ID x 50mm DX Bush	0113-MB3550DX	4
3	Grease Nipple 1/8" BSP 45 Deg	0181-GN1-845	2
4	PCH Wing Pivot Pin	0801-10-08-235	2
5	Cotter Pin M13 x 63	0261-PINC1363	2
6	Nyloc Nut M12	0221-NYL12	2
7	M12 x 80 Class 8.8 ZP Bolt	0211-1280	2

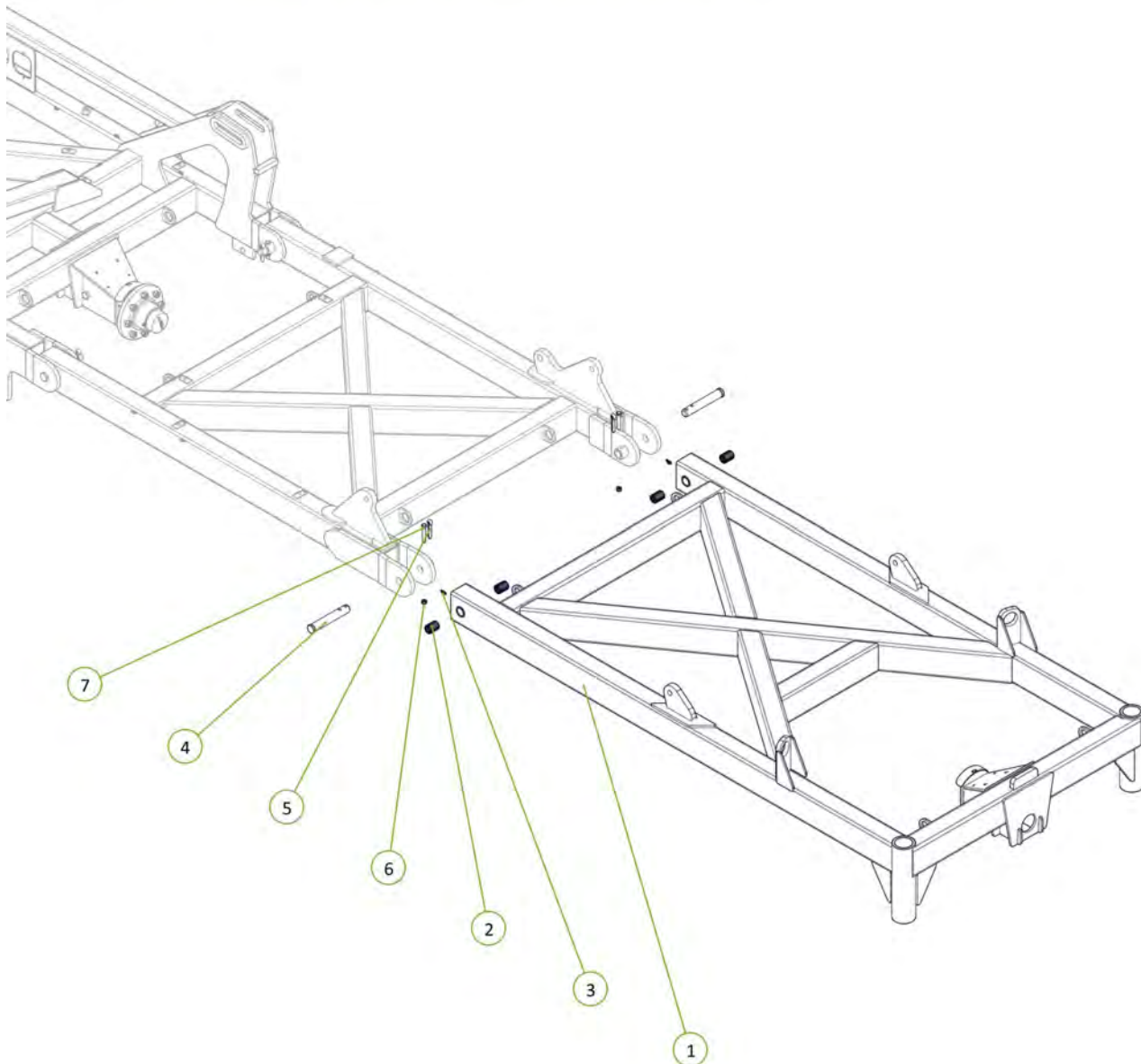

Item No.	Description	Number	Qty
1	40' RH Inner Wing Frame	0840-04	1
2	35 ID x 50mm DX Bush	0113-MB3550DX	4
3	Grease Nipple 1/8" BSP 45 Deg	0181-GN1-845	2
4	PCH Wing Pivot Pin	0801-10-08-235	2
5	Cotter Pin M13 x 63	0261-PINC1363	2
6	M12 x 80 Class 8.8 ZP Bolt	0211-1280	2
7	Nyloc Nut M12	0221-NYL12	2

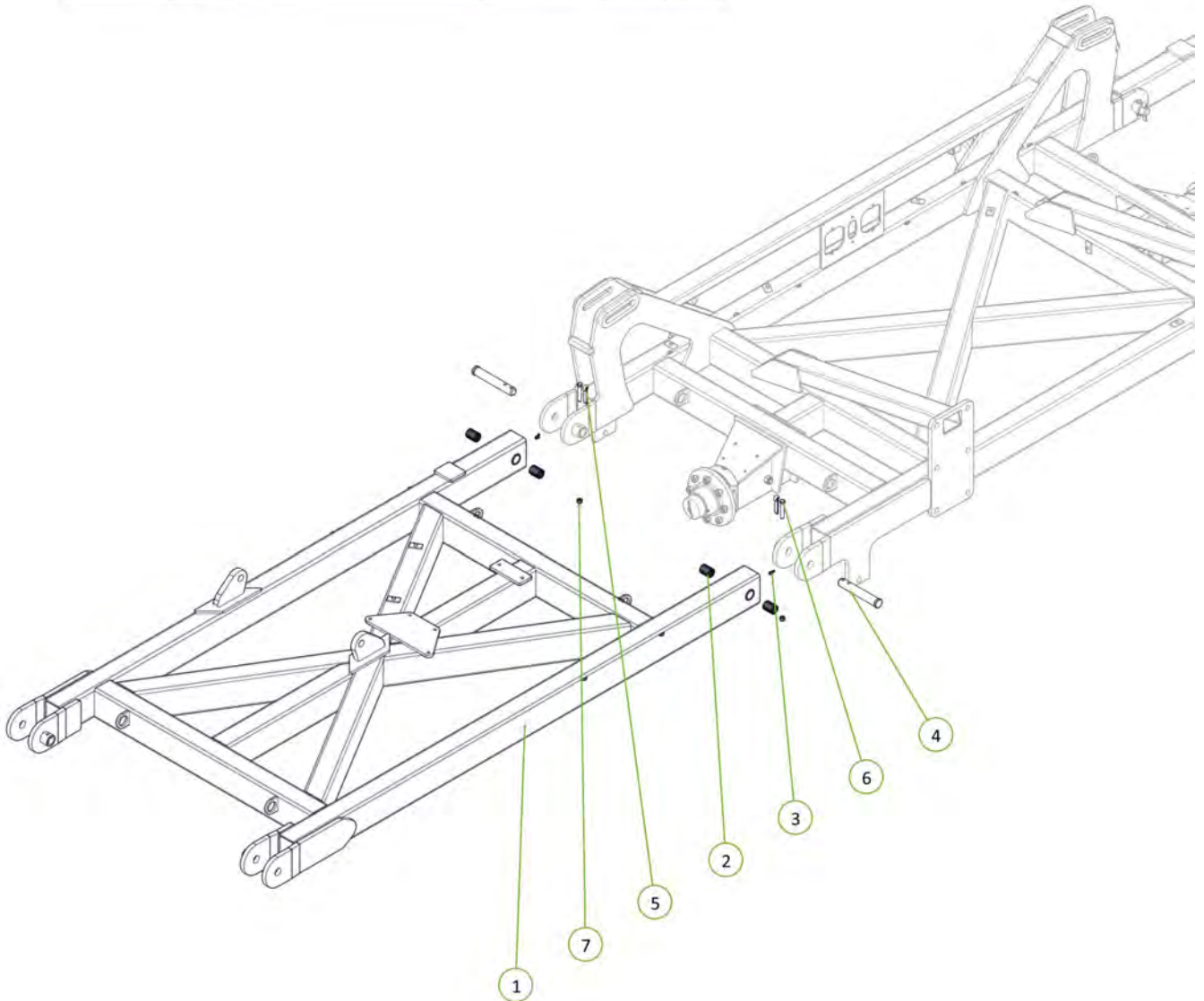

Item No.	Description	Number	Qty
1	RH Outer Wing Frame	0840-06	1
2	35 ID x 50mm DX Bush	0113-MB3550DX	4
3	Grease Nipple 1/8" BSP 45 Deg	0181-GN1-845	2
4	PCH Wing Pivot Pin	0801-10-08-235	2
5	Cotter Pin M13 x 63	0261-PINC1363	2
6	M12 x 80 Class 8.8 ZP Bolt	0211-1280	2
7	Nyloc Nut M12	0221-NYL12	2

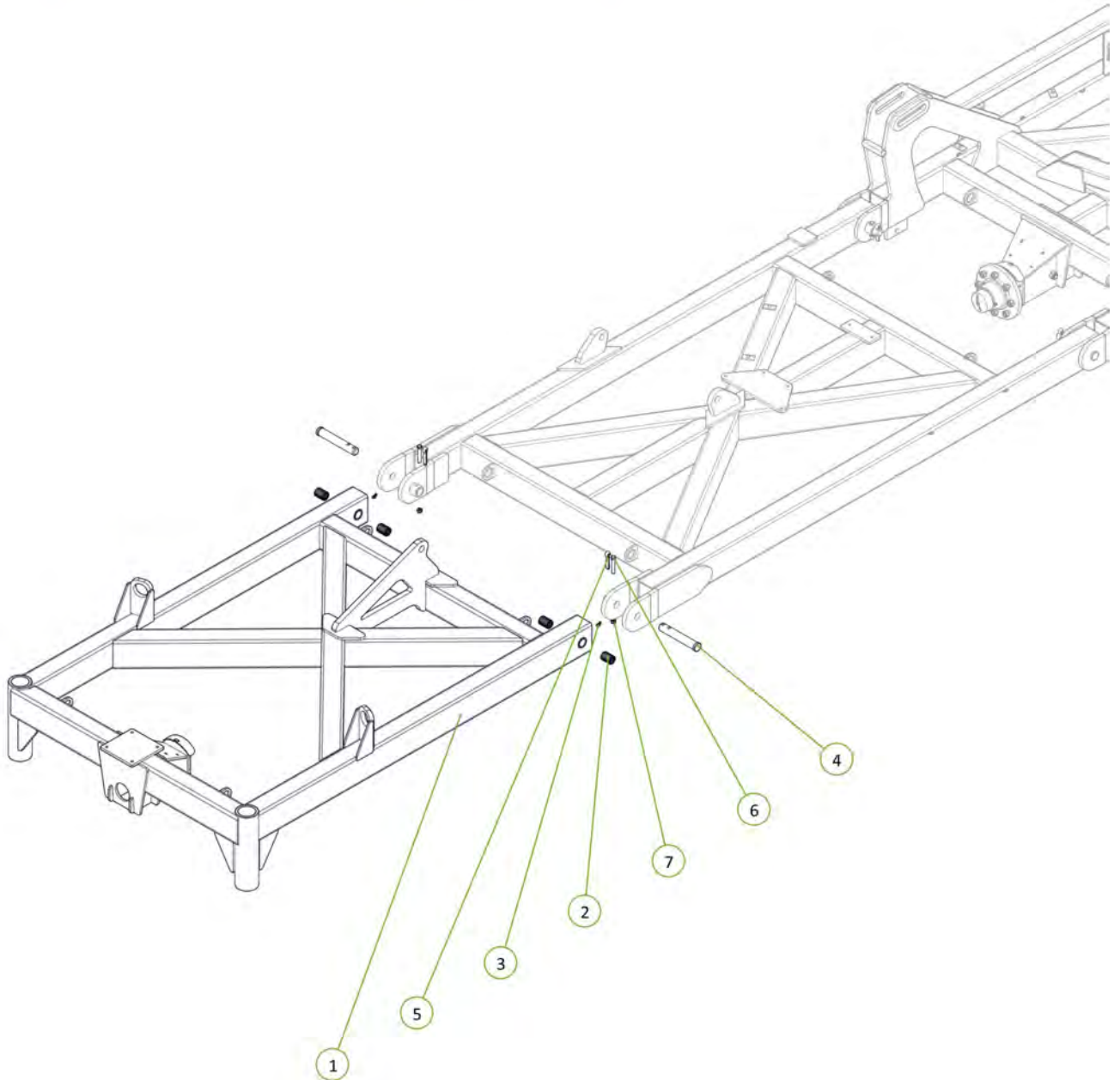

Item No.	Description	Number	Qty
1	40' Inner Wing Post	0840-04P	1
2	M12 x 50 grade 8.8 ZP Bolt	0211-1250	6
3	Nyloc Nut M12	0221-NYL12	6
4	Washer Flat M12	0231-F12	12

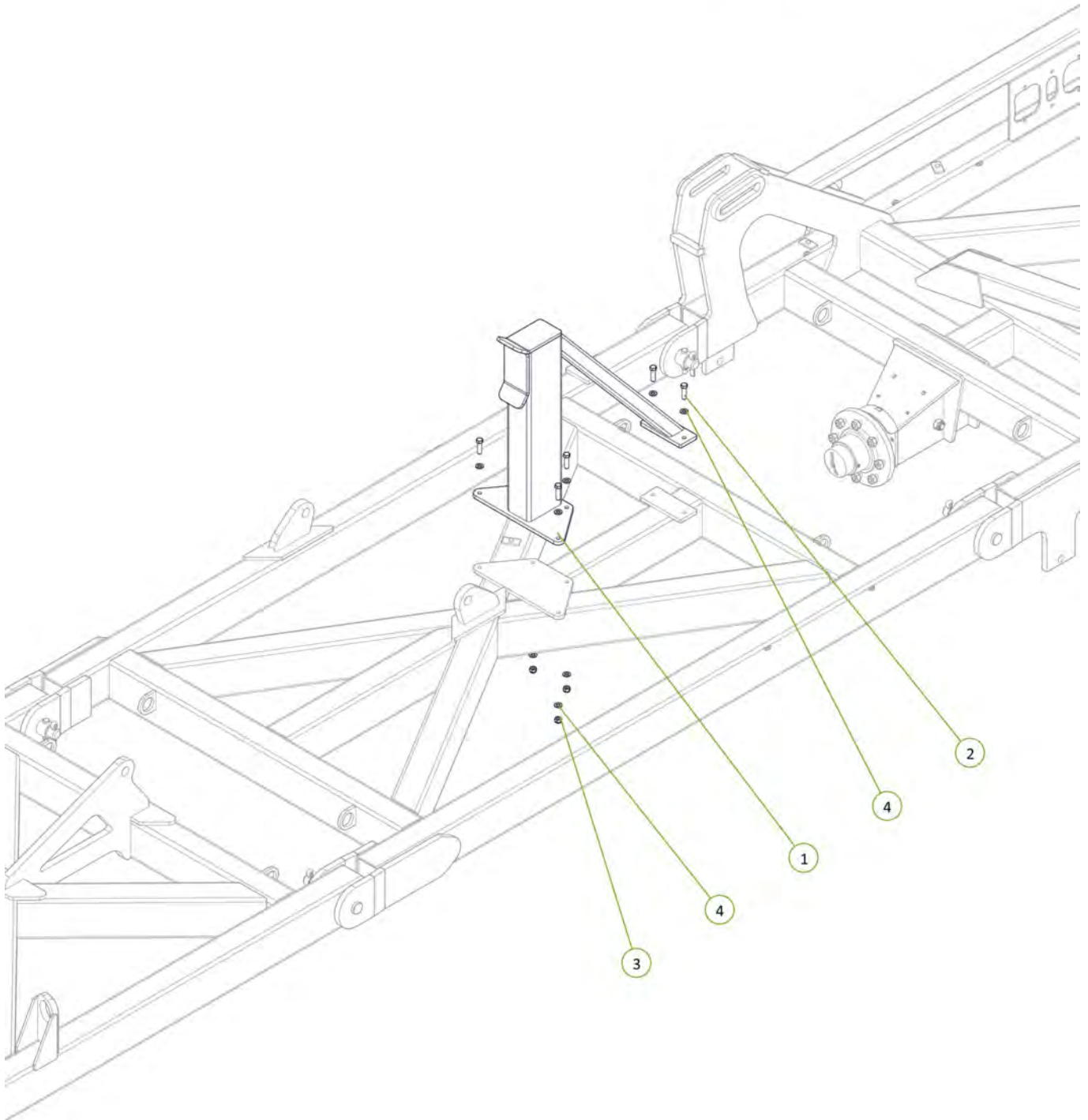
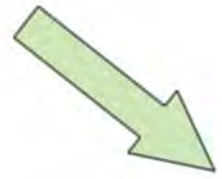

Item No.	Description	Number	Qty
1	40' Outer Wing Post	0840-06P	1
2	M12 x 40 grade 8.8 ZP Bolt	0211-1240	4
3	Nyloc Nut M12	0221-NYL12	4
4	Washer Flat M12	0231-F12	8

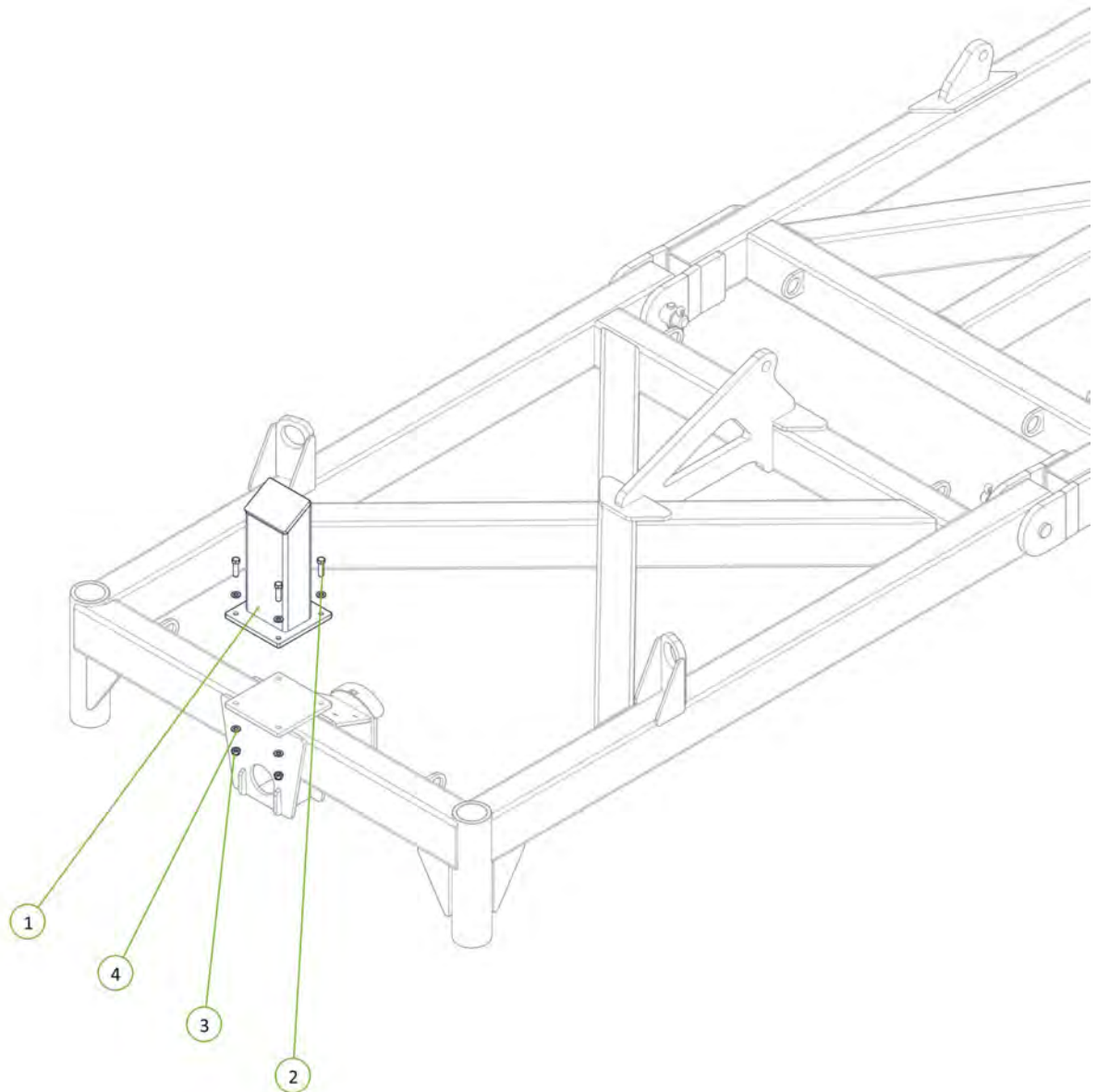

Item No.	Description	Number	Qty
1	Dual Circuit 3 Stage Sequence Manifold V12.5	0802-692196	1
2	M10 x 25 grade 8.8 ZP Bolt	0211-1025	6
3	Washer Flat M10	0231-F10	6
4	Washer Spring M10	0231-S10	6

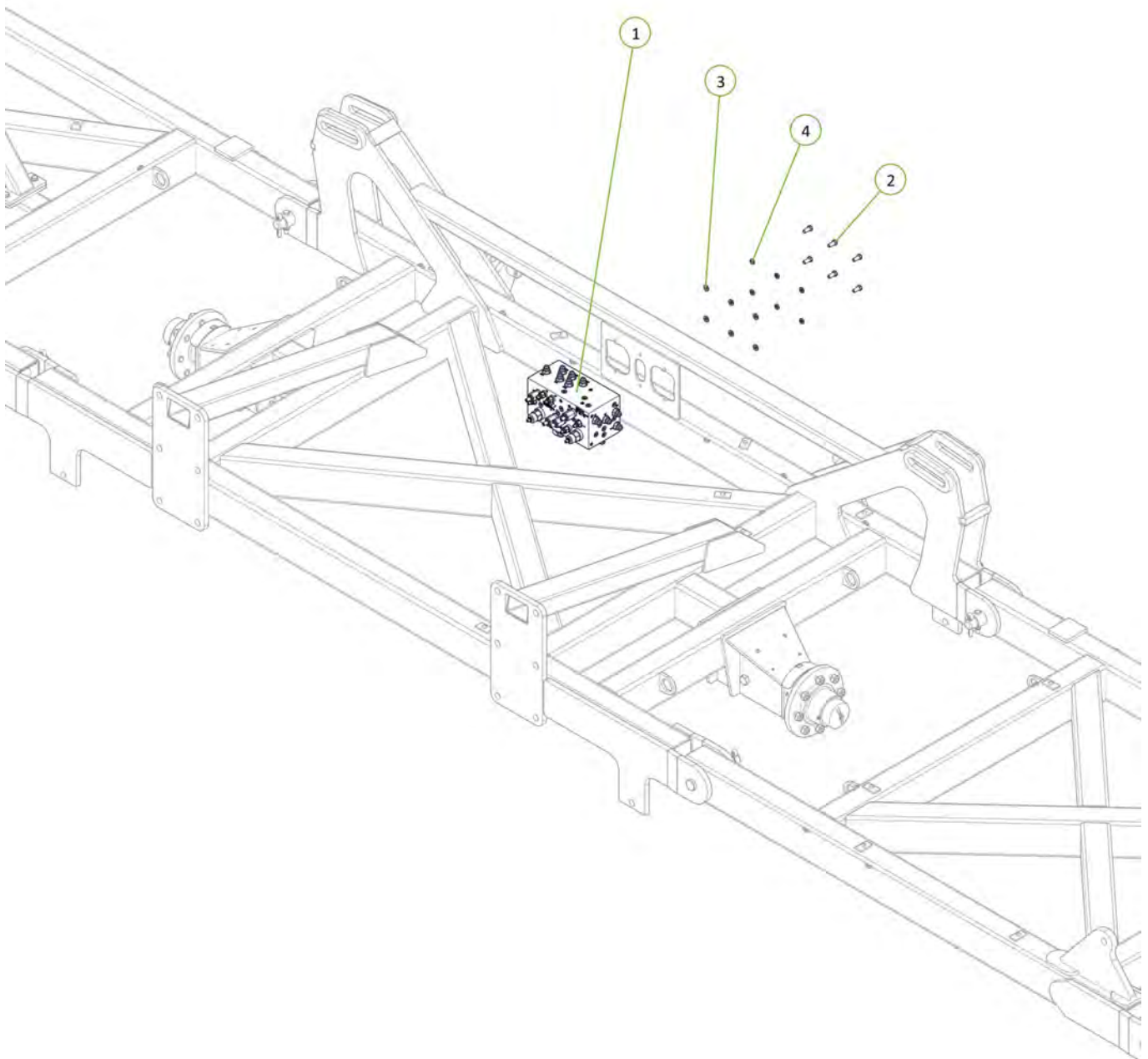

Item No.	Description	Number	Qty
1	5" Bore x 30" Stroke 2" Rod Cylinder with 3-1/8" Stop Tube	0311-530ST	1

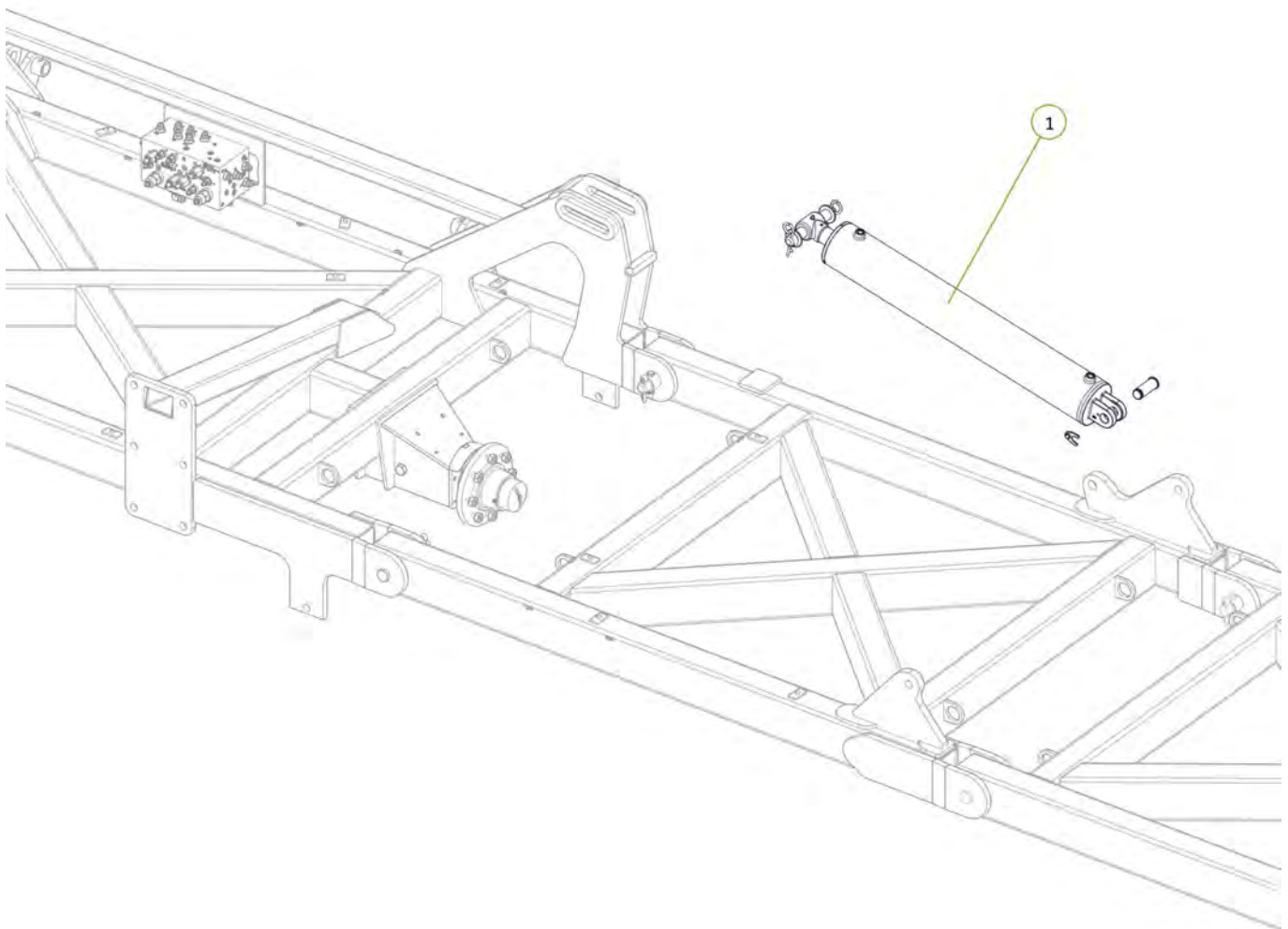

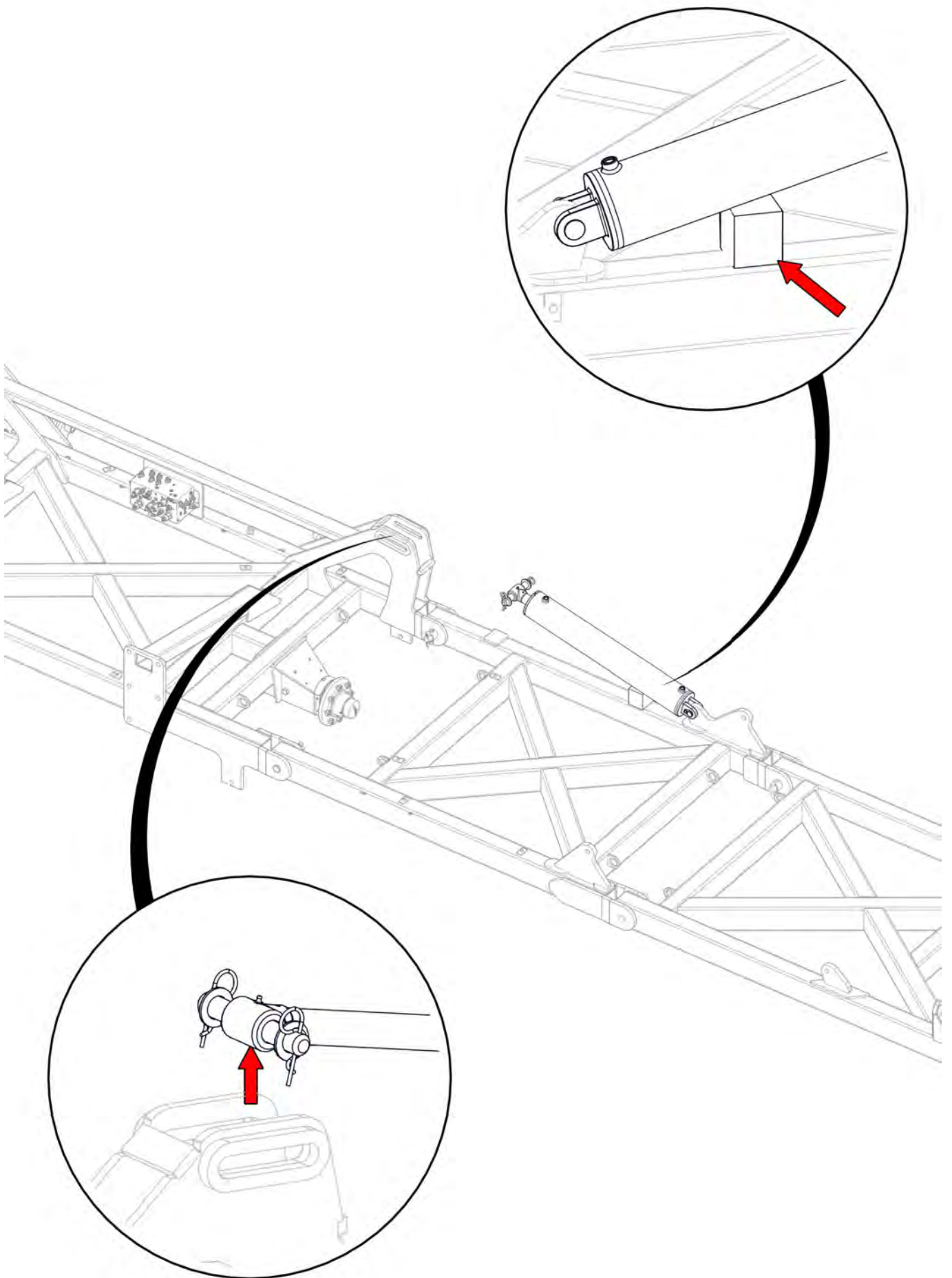

Item No.	Description	Number	Qty
1	3/4" JIC Male 3/4" UN O Ring Male 90° Elbow	0323-S91-1212	2

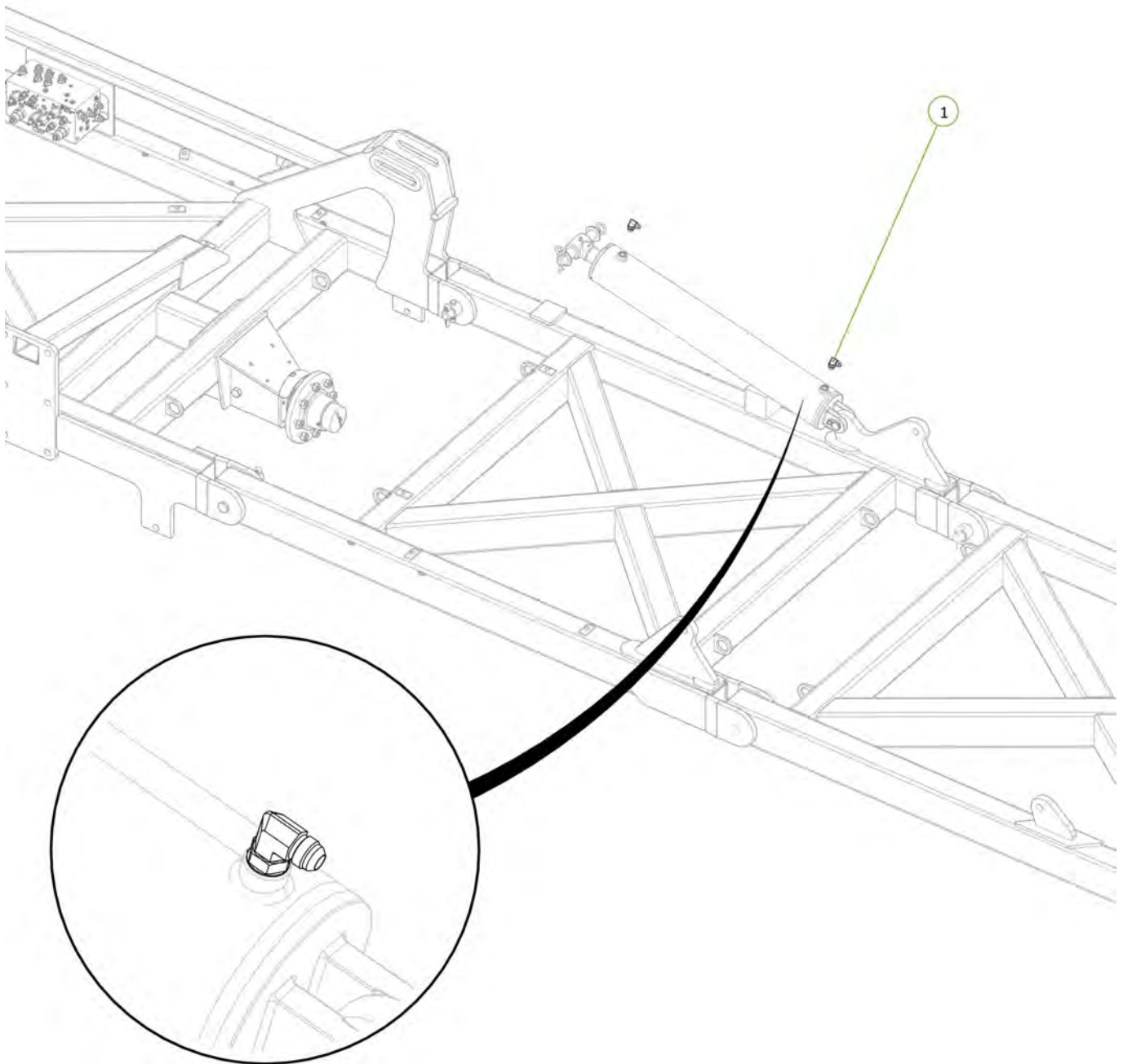
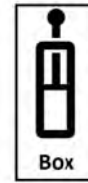

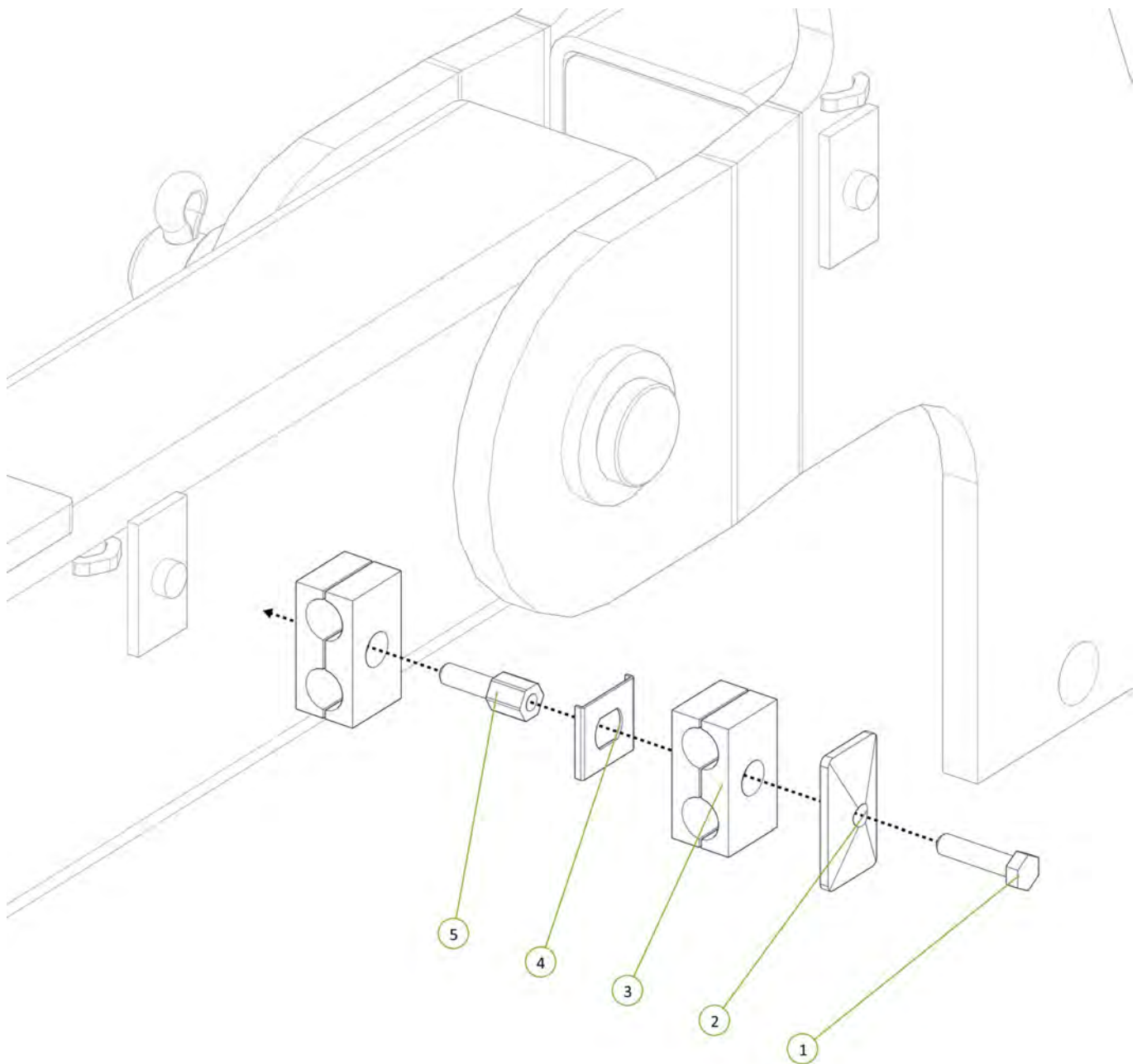

Item No.	Description	Number	Qty
1	Double Clamp Bolt Group 2	0325-RCD-2BH	1
2	Clamp top plate group 2	0325-RCD-2PT	1
3	17mm Clamp Jaws (Pair)	0325-RCD-17J	2
4	Double Clamp Stacking Plate (Non Ryco)	0325-SI-2-5D-W3	1
5	Double Clamp Stacking Bolt Group 2	0325-RCD-2BS	1

Item No.	Description	Number	Qty
1	Left CR Port to LH Main Wing Cylinder Retract Port	PH40-06L	1
2	Left CE Port to LH Main Wing Cylinder Extend Port	PH40-07L	1

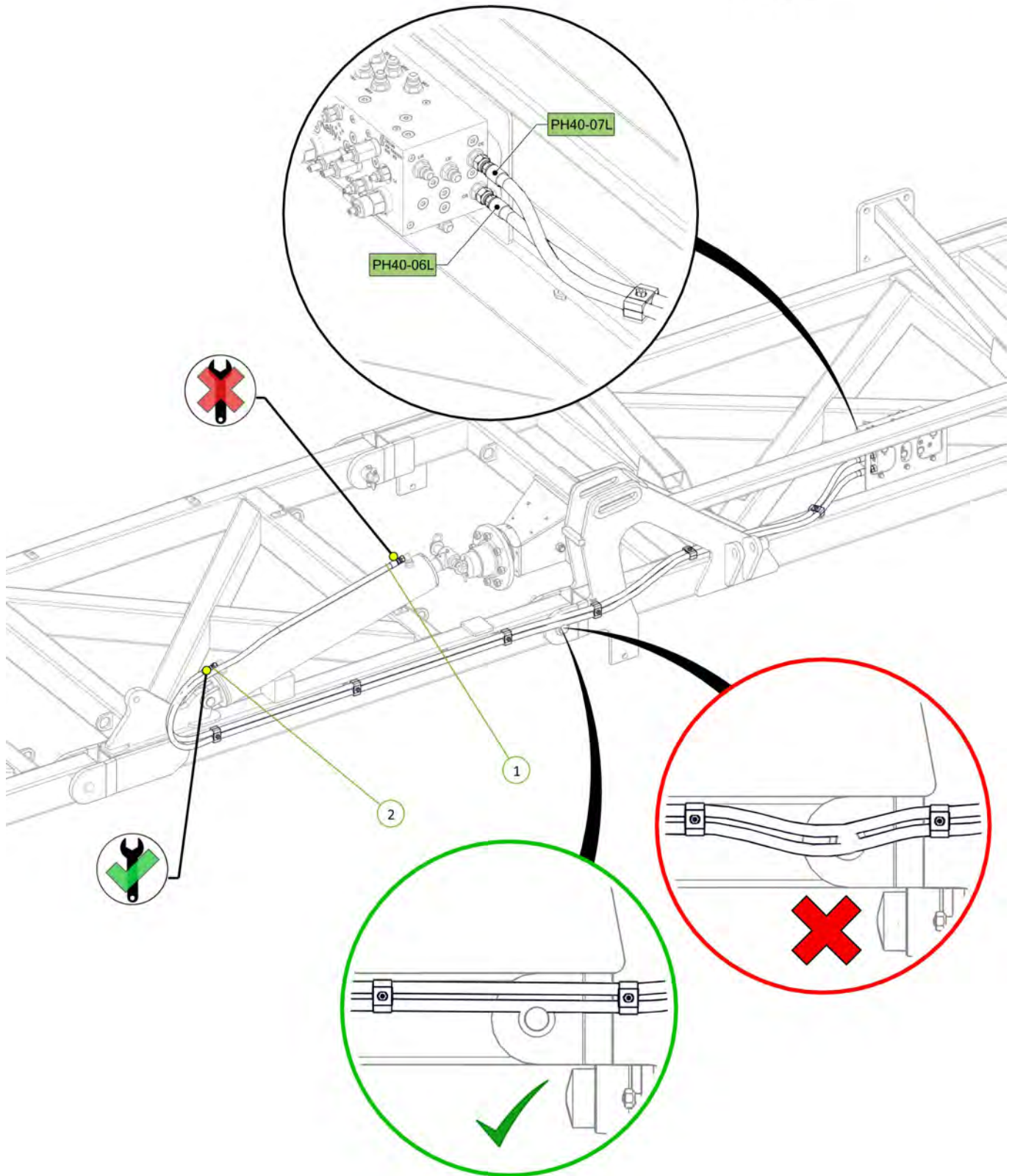

Item No.	Description	Number	Qty
1	5" Bore x 30" Stroke 2" Rod Cylinder with 3-1/8" Stop Tube	0311-530ST	1

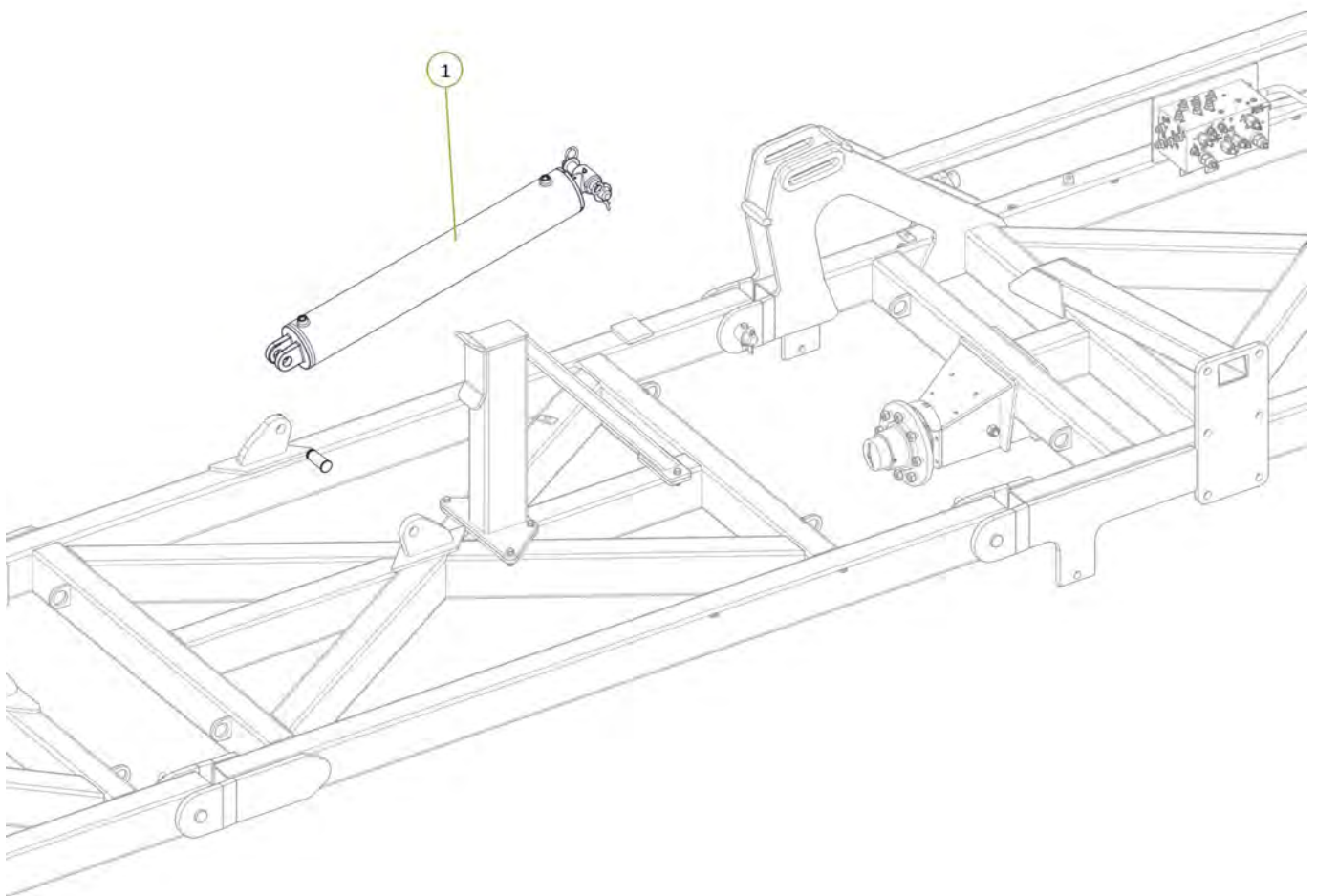

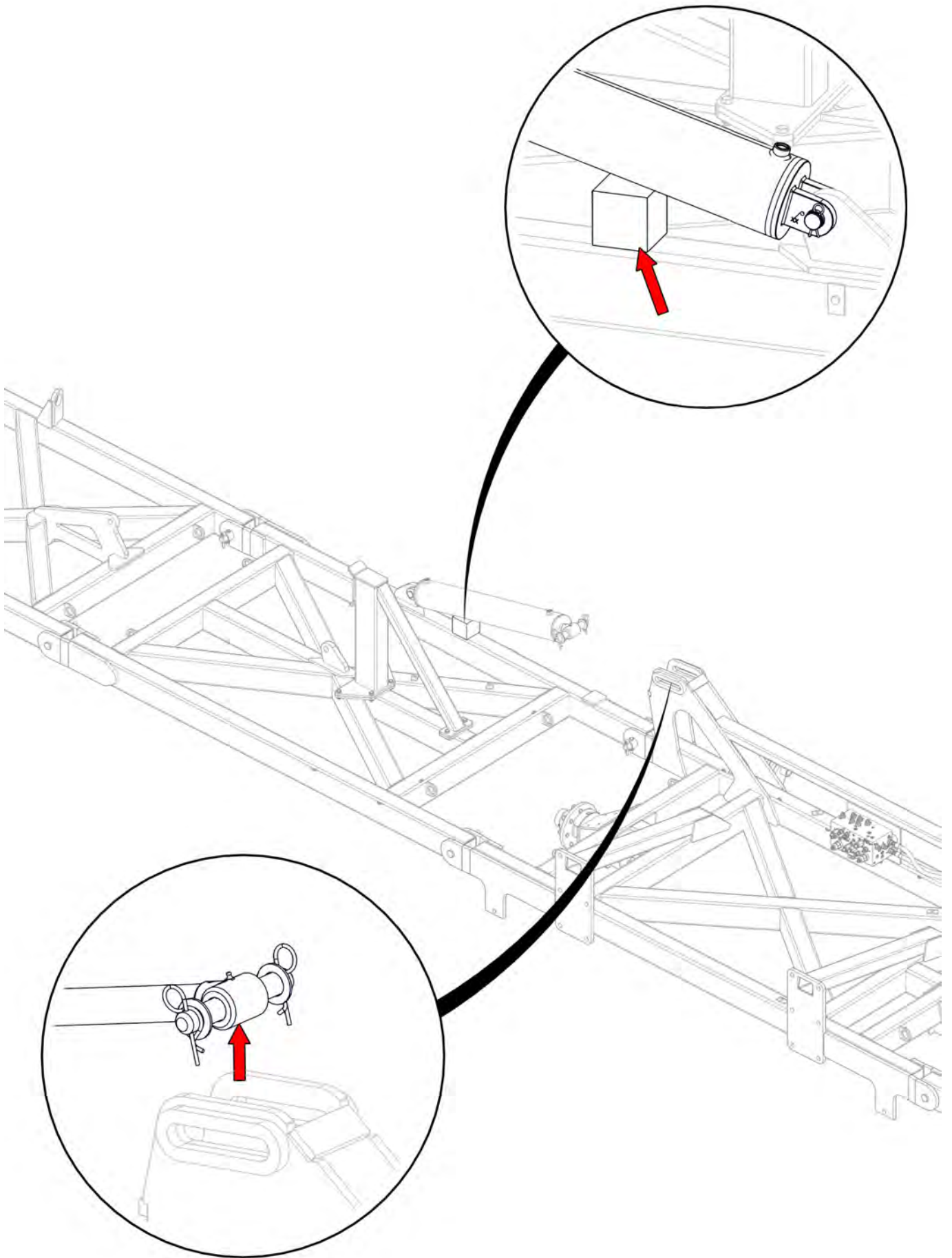

Item No.	Description	Number	Qty
1	3/4" JIC Male 3/4" UN O Ring Male 90° Elbow	0323-S91-1212	2

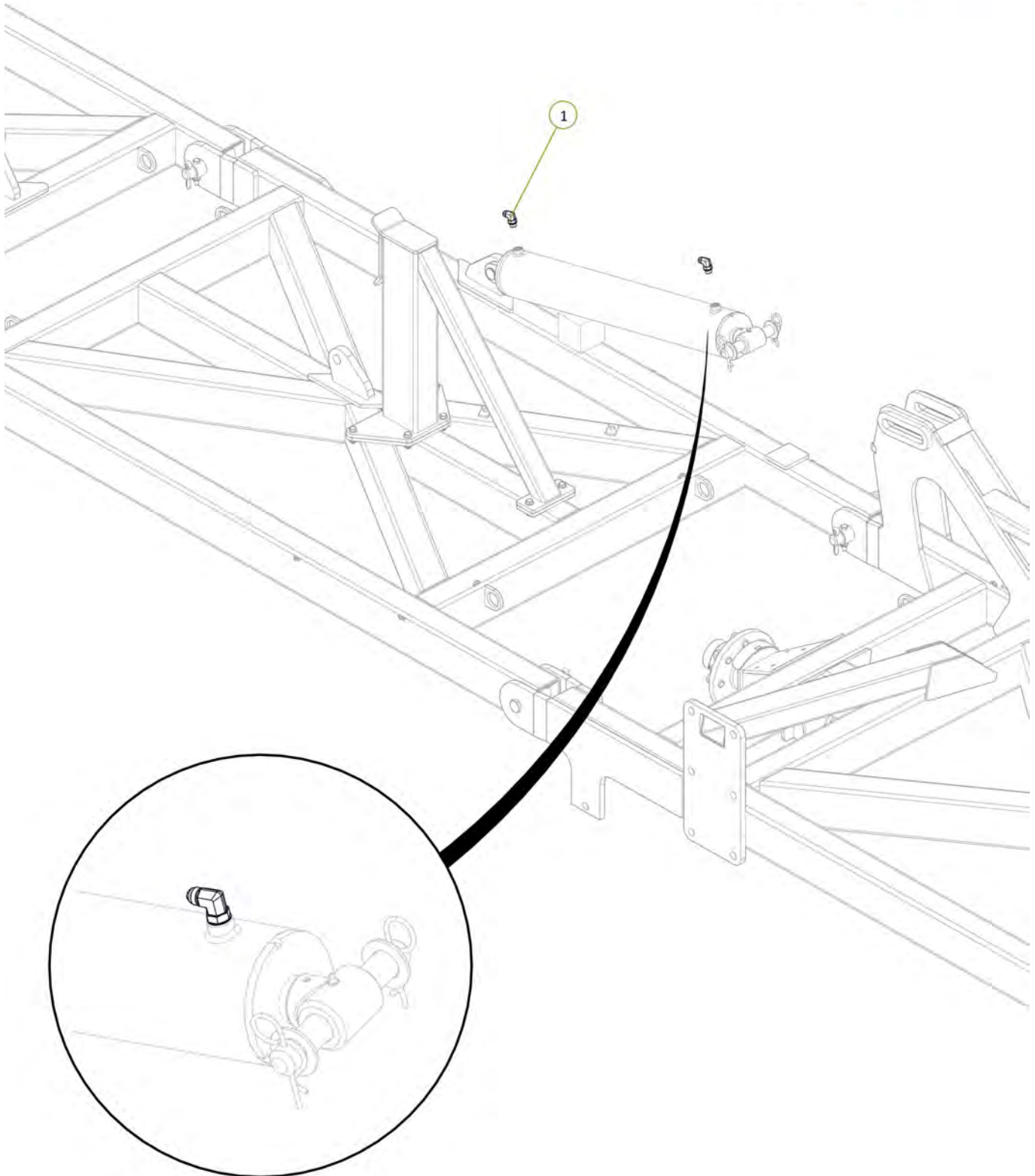
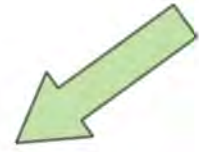

Item No.	Description	Number	Qty
1	Right CR Port to RH Main Wing Cylinder Retract Port	PH40-06R	1
2	Right CE Port to RH Main Wing Cylinder Extend Port	PH40-07R	1

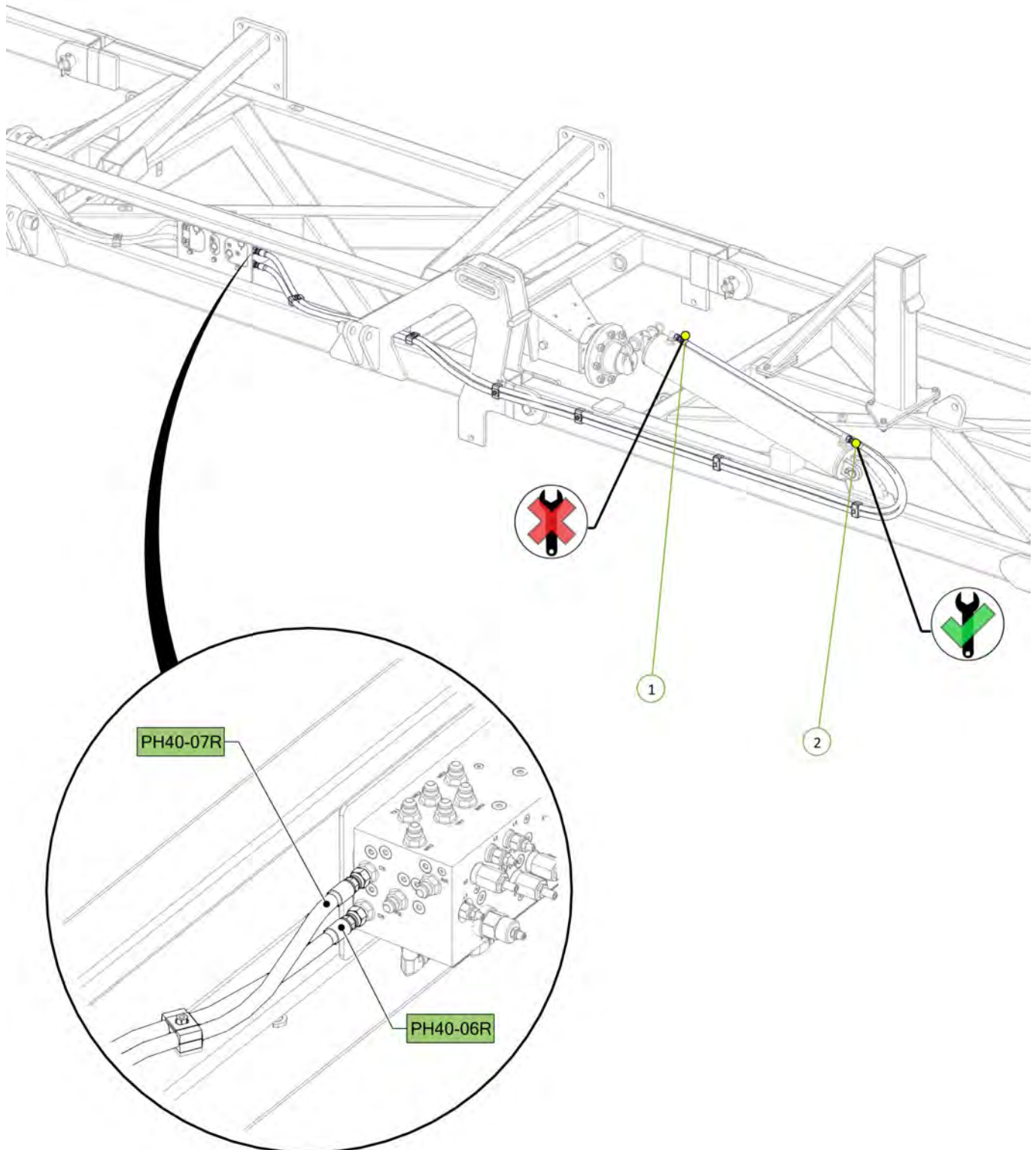

Item No.	Description	Number	Qty
1	3" Bore x 24" Stroke 1.5" Rod Hydraulic Cylinder Stop Tube Side Port	0311-324STSP	2

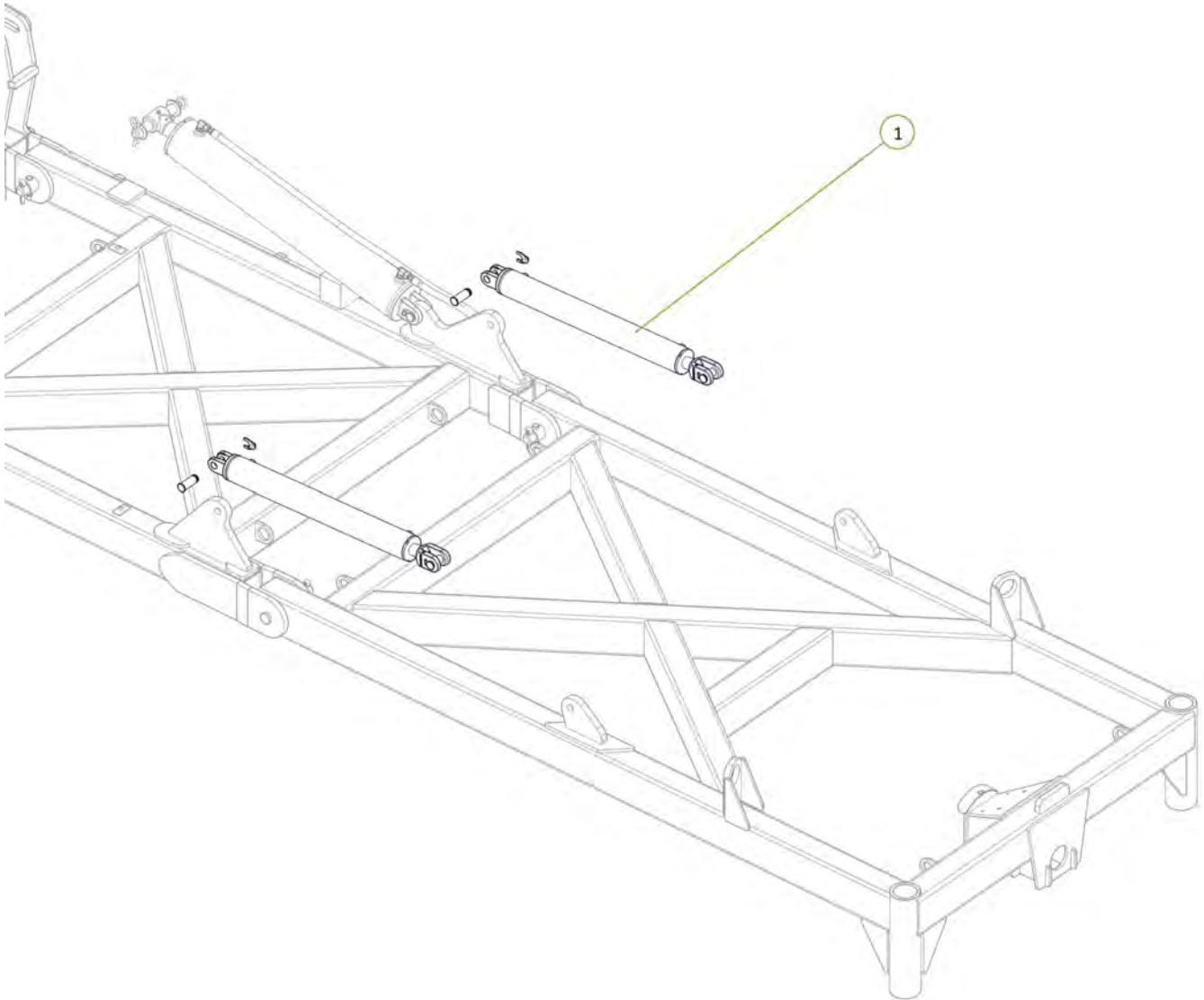

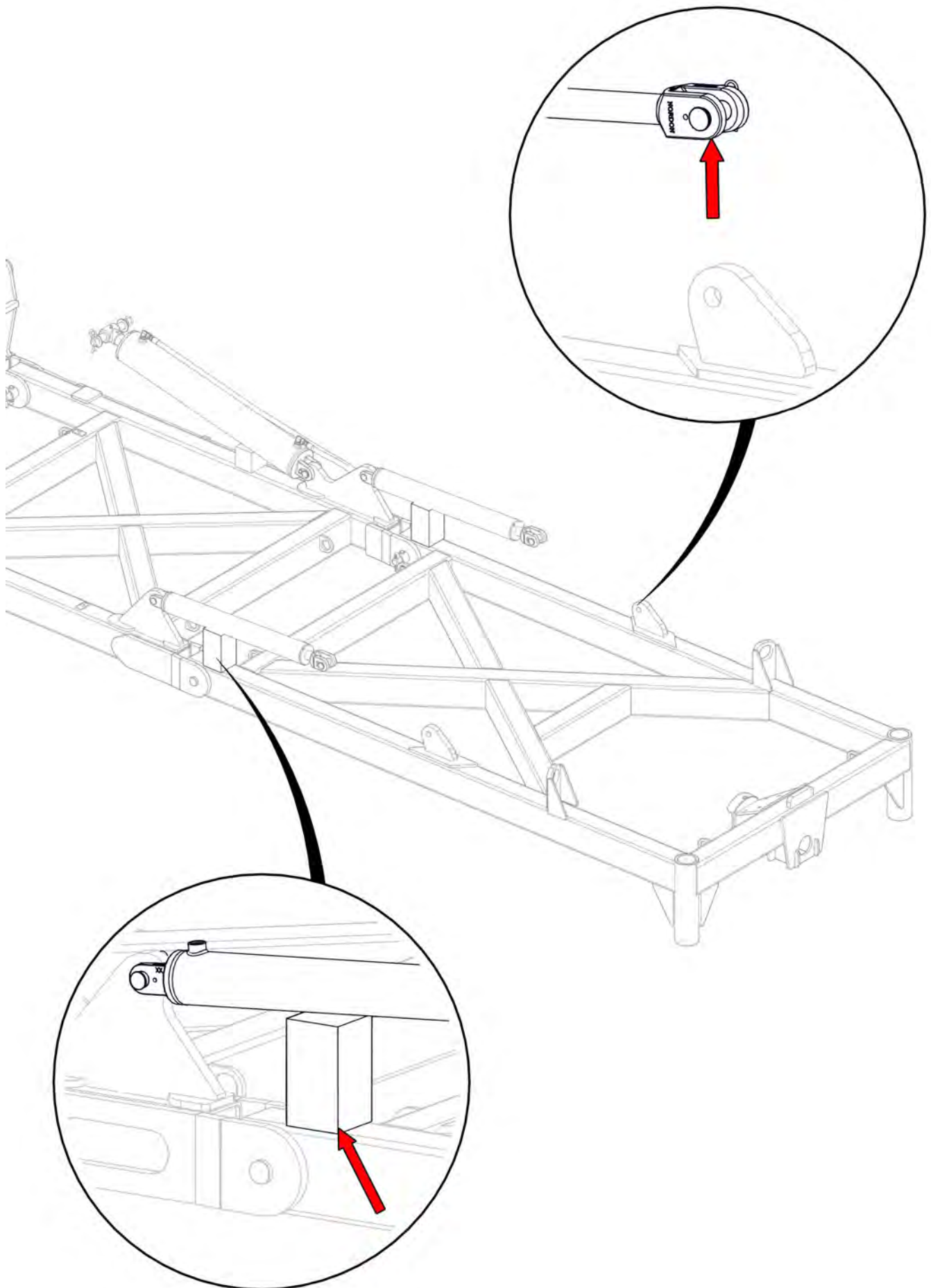

Item No.	Description	Number	Qty
1	3/4" JIC Male 3/4" UN O Ring Male 90° Elbow	0323-S91-1212	4

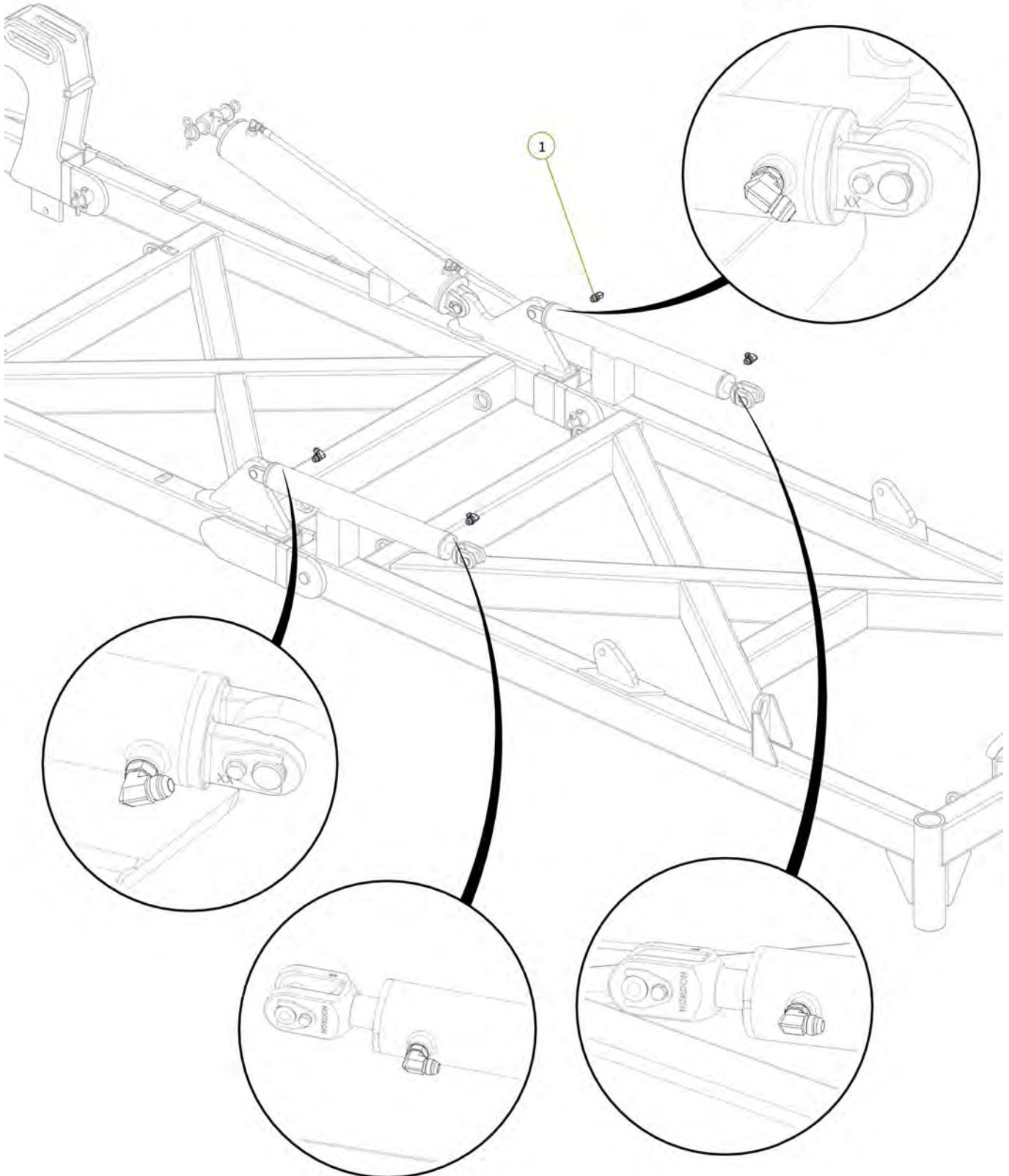

Item No.	Description	Number	Qty
1	LR port to LH Wing Retract Tee	PH40-08L	1
2	LE Port to LH Wing Extend Tee	PH40-09L	1
3	3/4" JIC Male Tee 3/4" JIC Male Tee 3/4" JIC Male Tee	0324-S19-121212	2
4	3/4" JIC Male 3/4" JIC Female Swivel 90° Elbow	0323-S15-1212	1

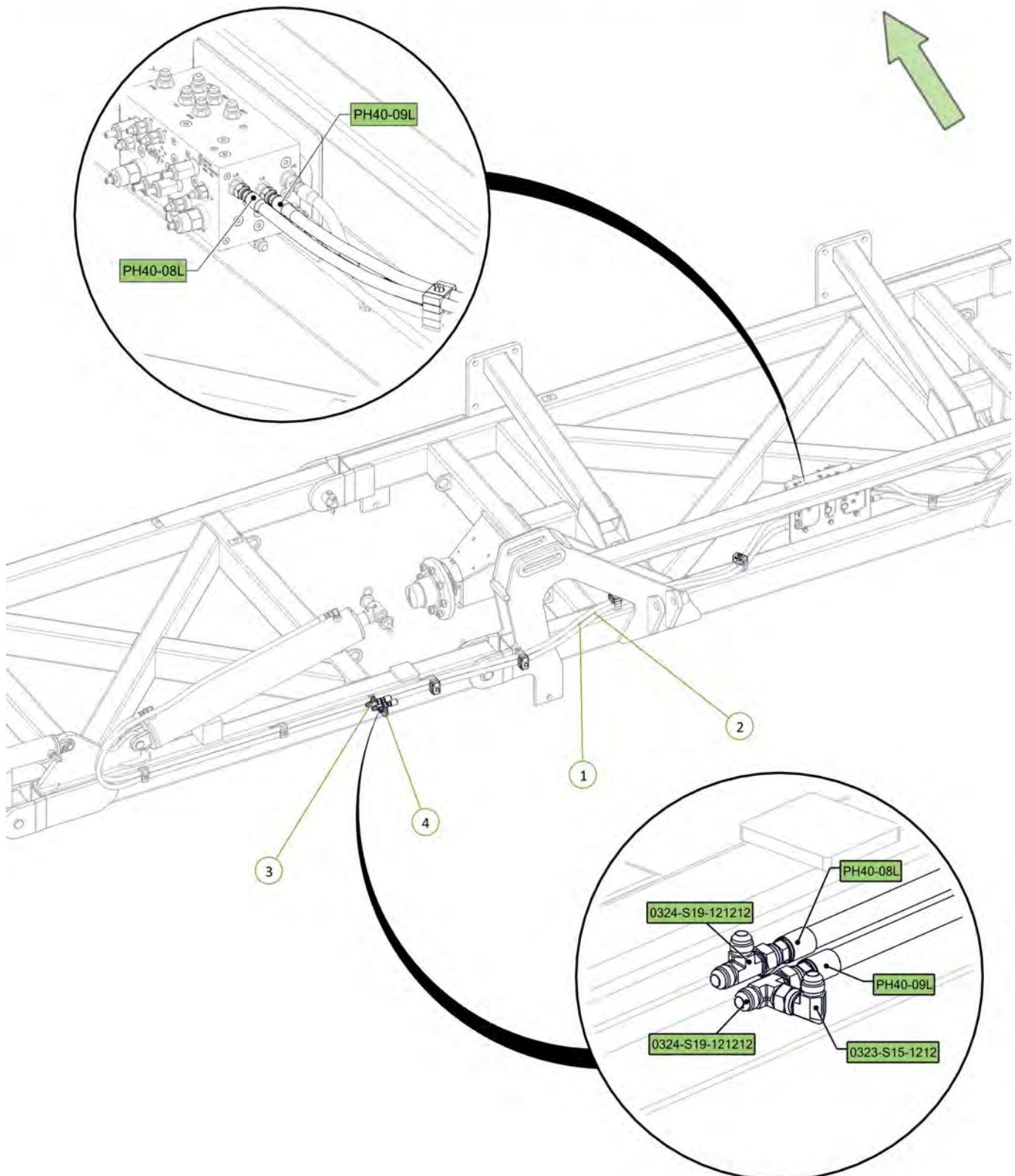

Item No.	Description	Number	Qty
1	LH Wing Extend Tee to Rear LH Outer Wing Cylinder Extend Port	PH40-12	1
2	LH Wing Retract Tee to Rear LH Outer Wing Cylinder Retract Port	PH40-13	1

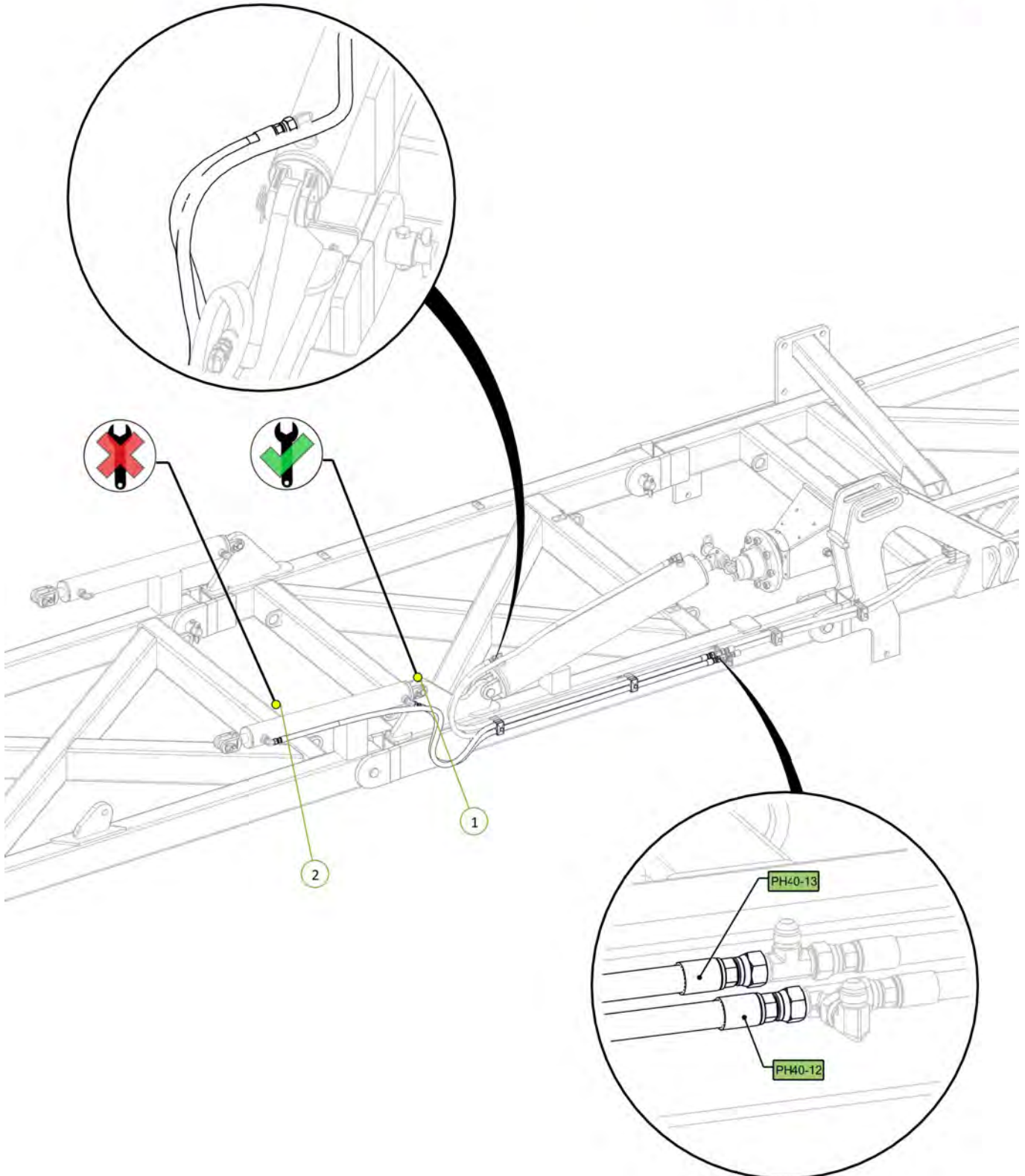

Item No.	Description	Number	Qty
1	LH Wing Extend Tee to Front LH Outer Wing Cylinder Extend Port	PH40-10	1
2	LH Wing Retract Tee to Front LH Outer Wing Cylinder Retract Port	PH40-11	1

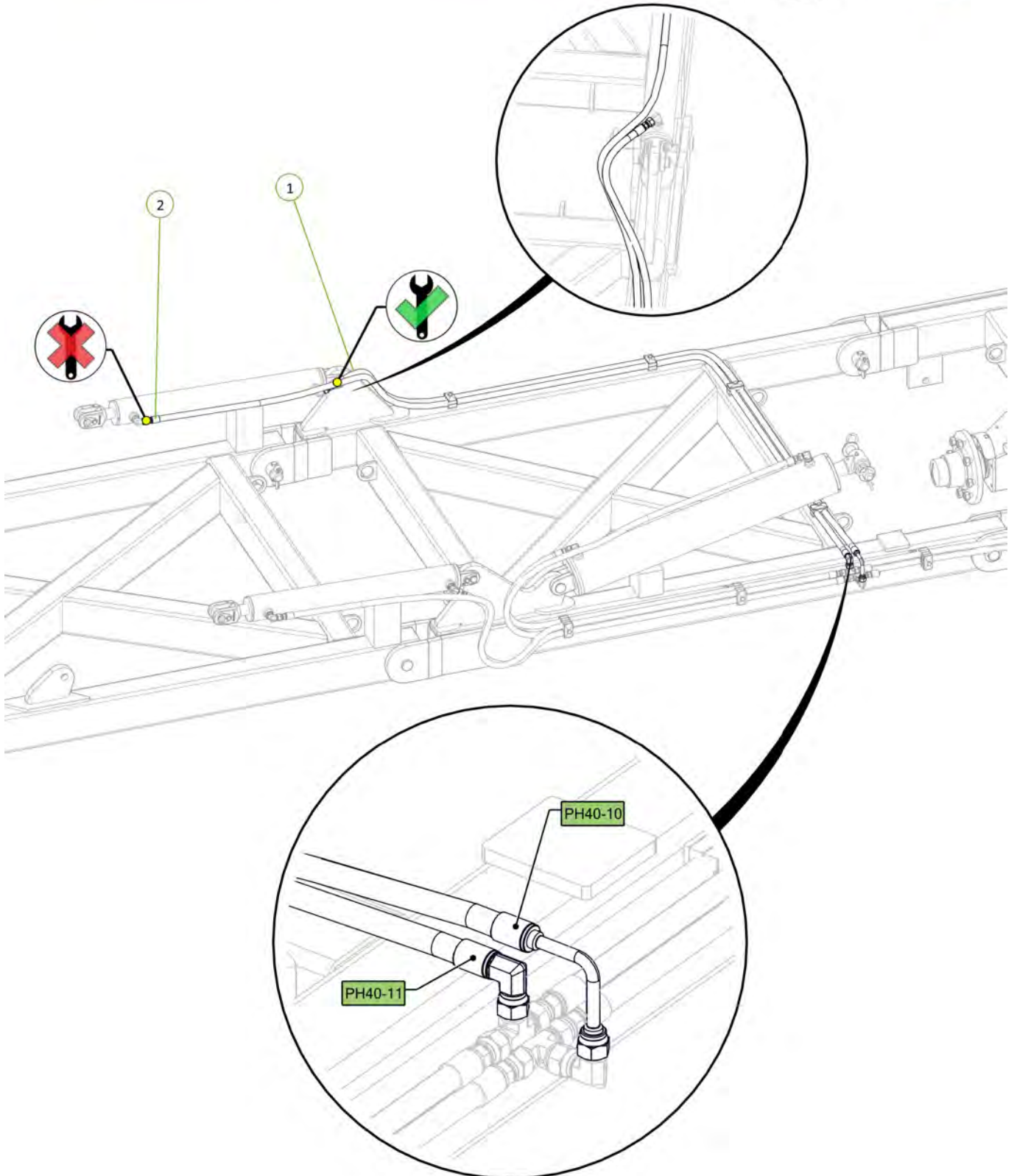

Item No.	Description	Number	Qty
1	4" Bore 24" Stroke 1.75" Rod Hydraulic Cylinder	0311-424	1

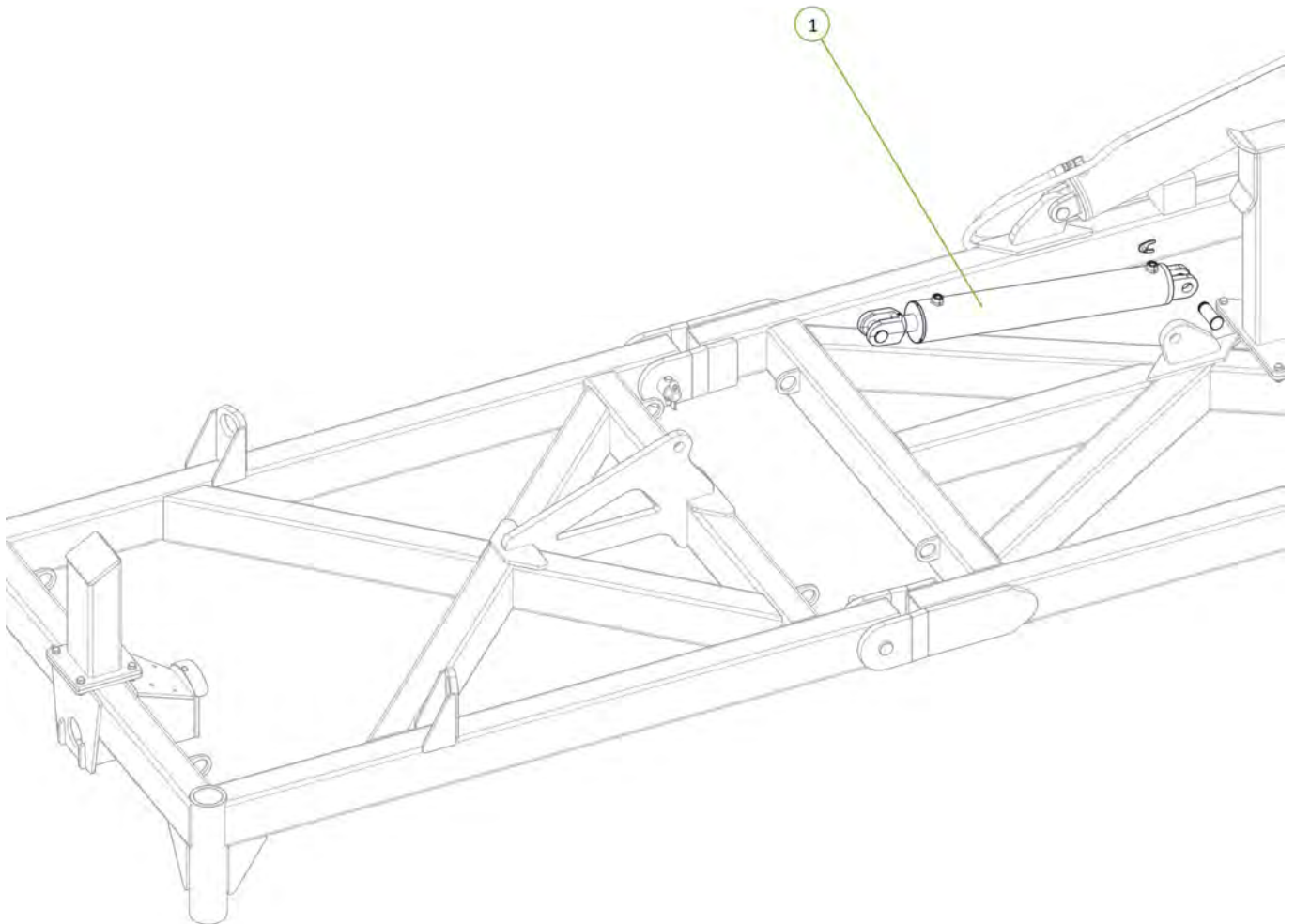

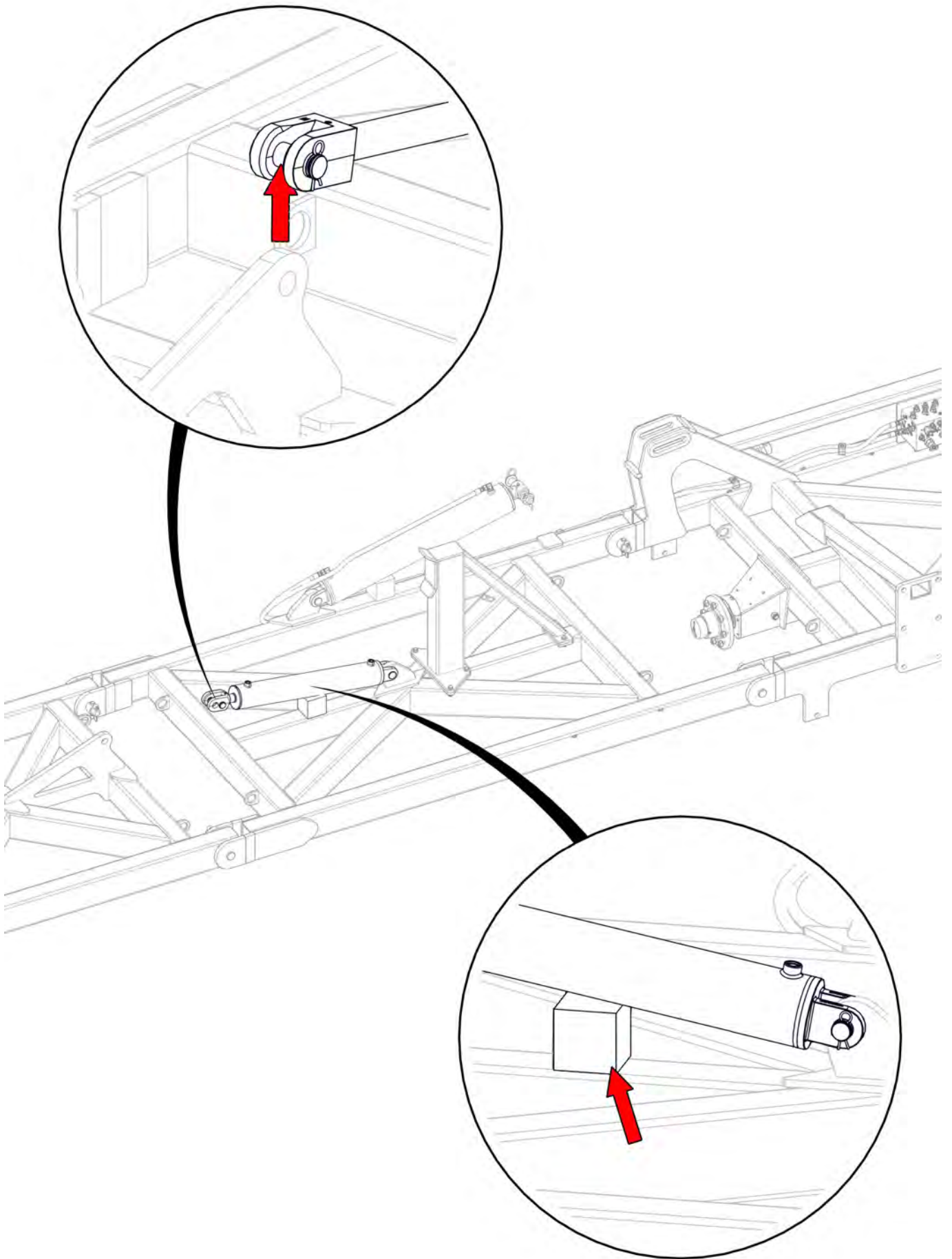

Item No.	Description	Number	Qty
1	3/4" JIC Male 3/4" UN O Ring Male 90° Elbow	0323-S91-1212	2

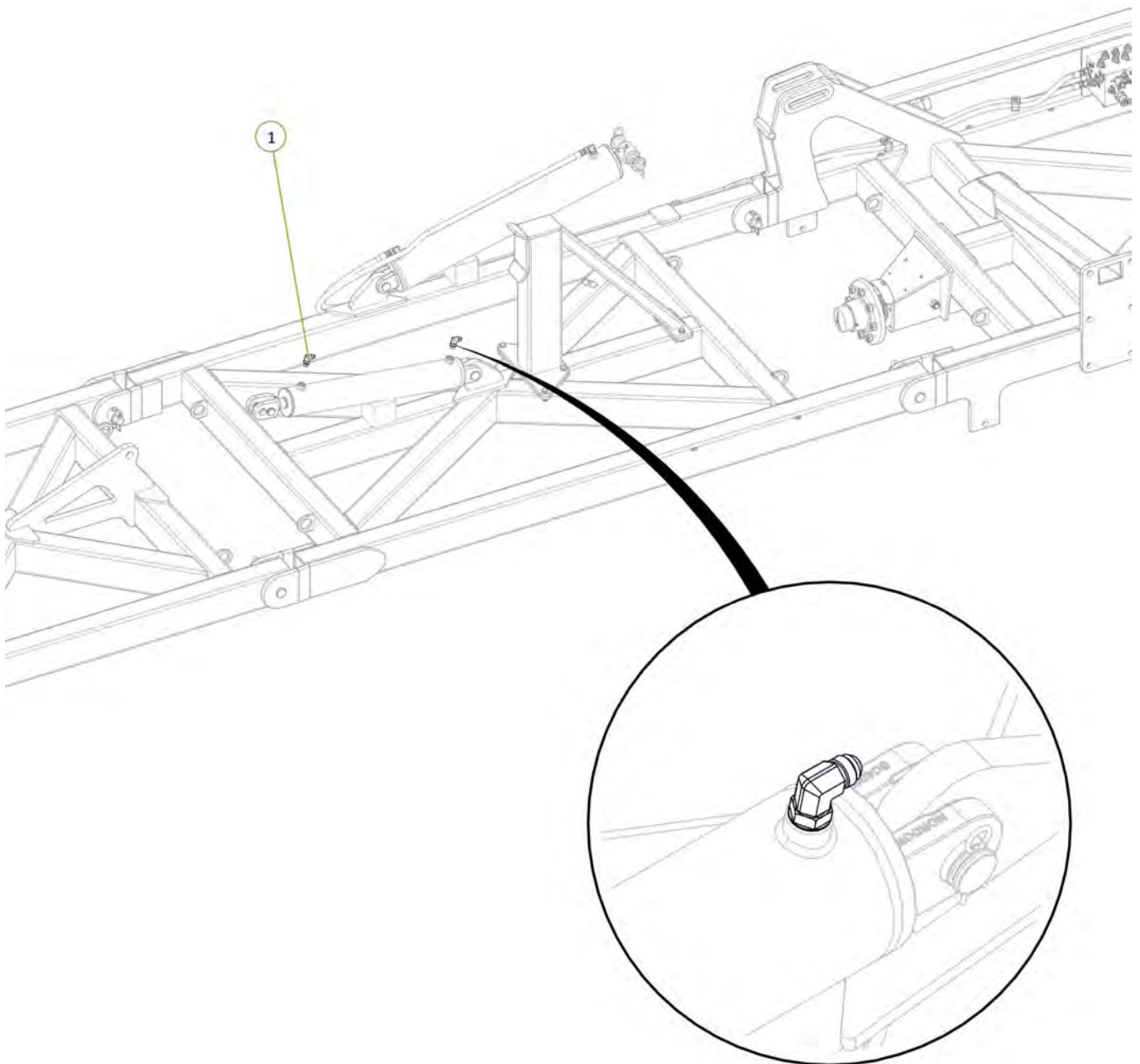

Item No.	Description	Number	Qty
1	RR Port to RH Outer Wing Cylinder Retract Port	PH40-08R	1
2	RE Port to RH Outer Wing Cylinder Extend Port	PH40-09R	1

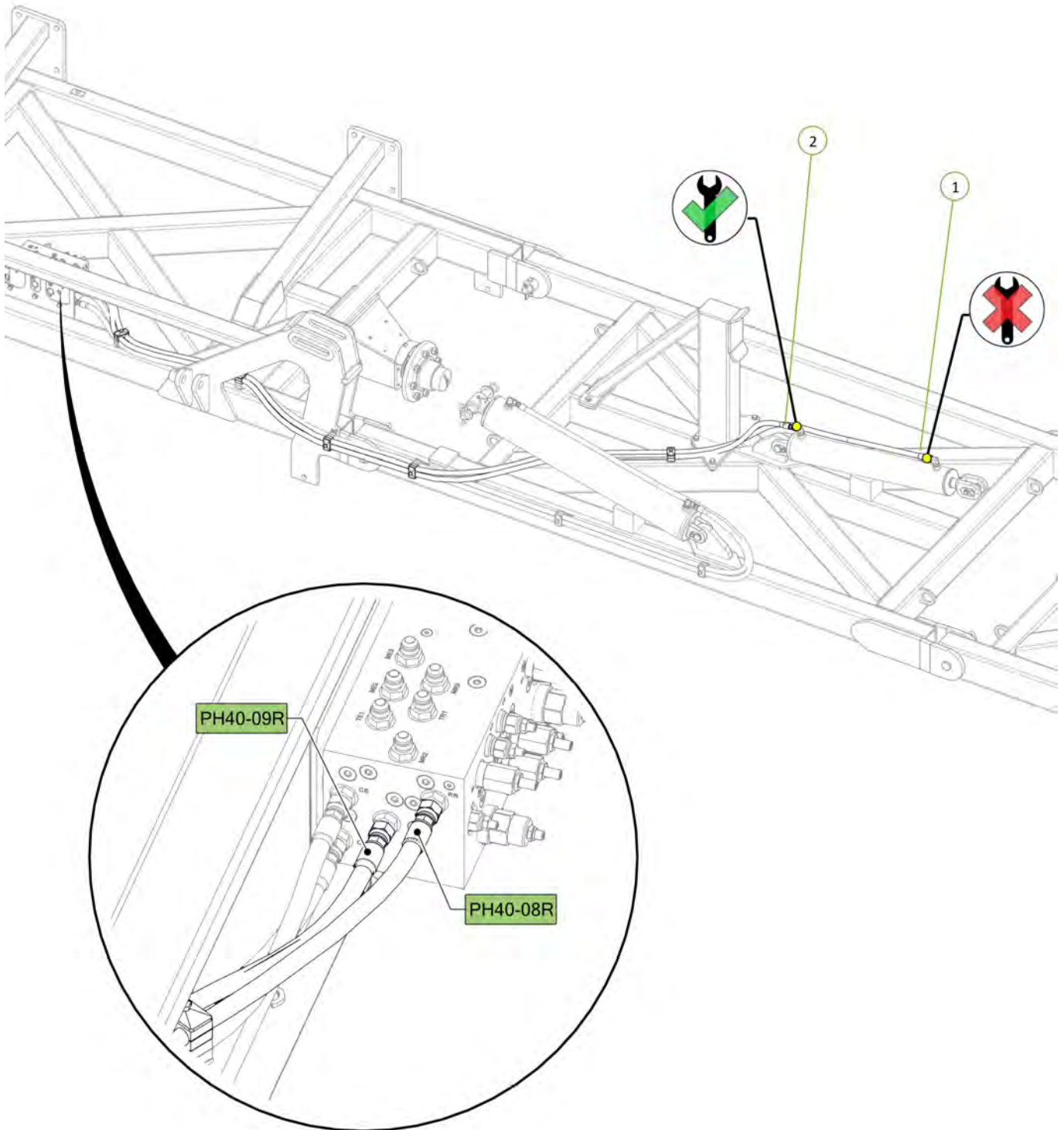

Item No.	Description	Number	Qty
1	Tractor to Sequence Valve EXT1 Port Fitted with Green Extend Decal	PH40-01-GE-EXT1	1
2	Tractor to Sequence Valve RCT1 Port Fitted with Green Retract Decal	PH40-01-GR-RCT1	1

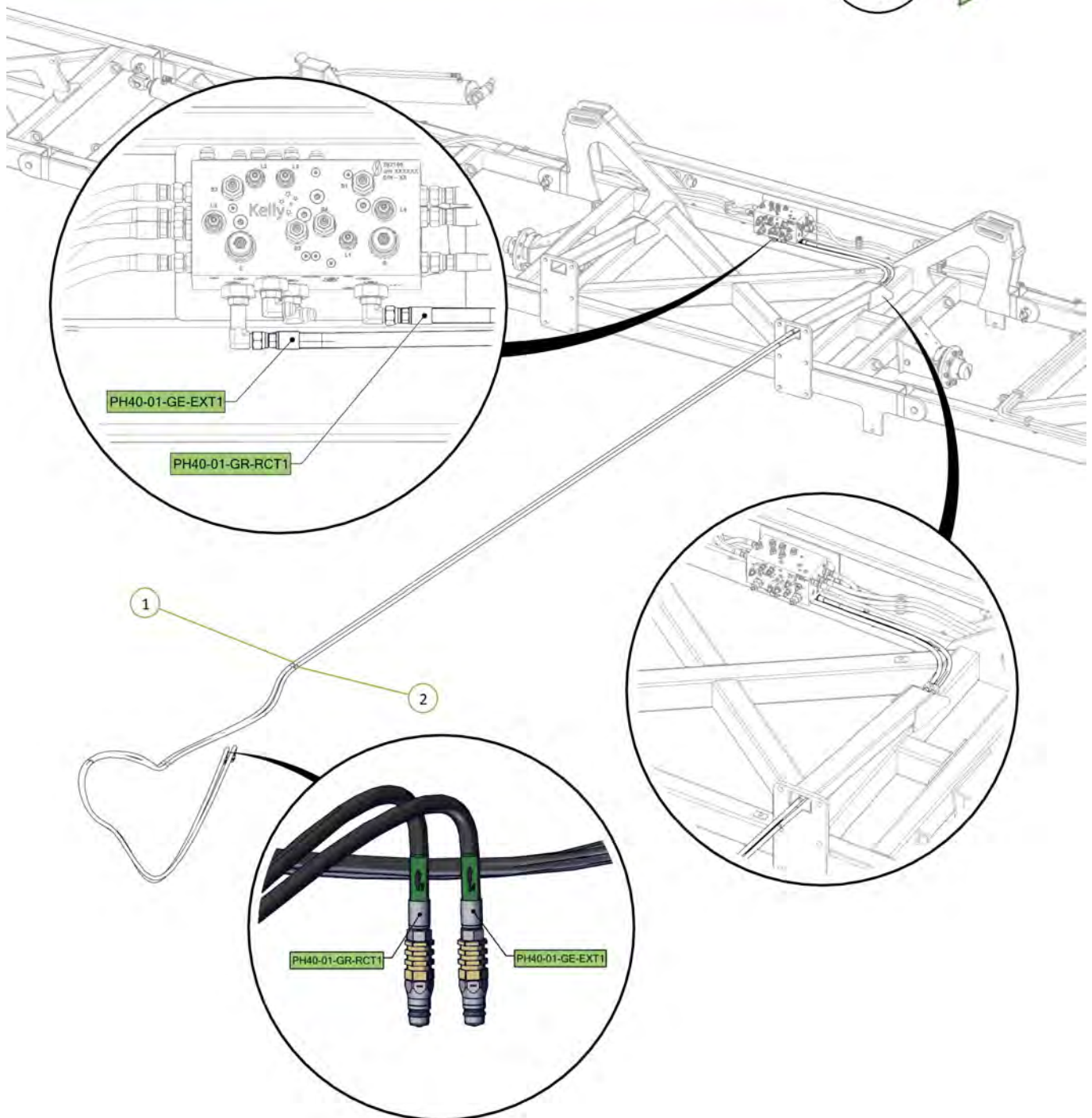

Ensure retract hose fittings are loose to allow air to escape

Check cylinders are chocked up to prevent clashing during extension

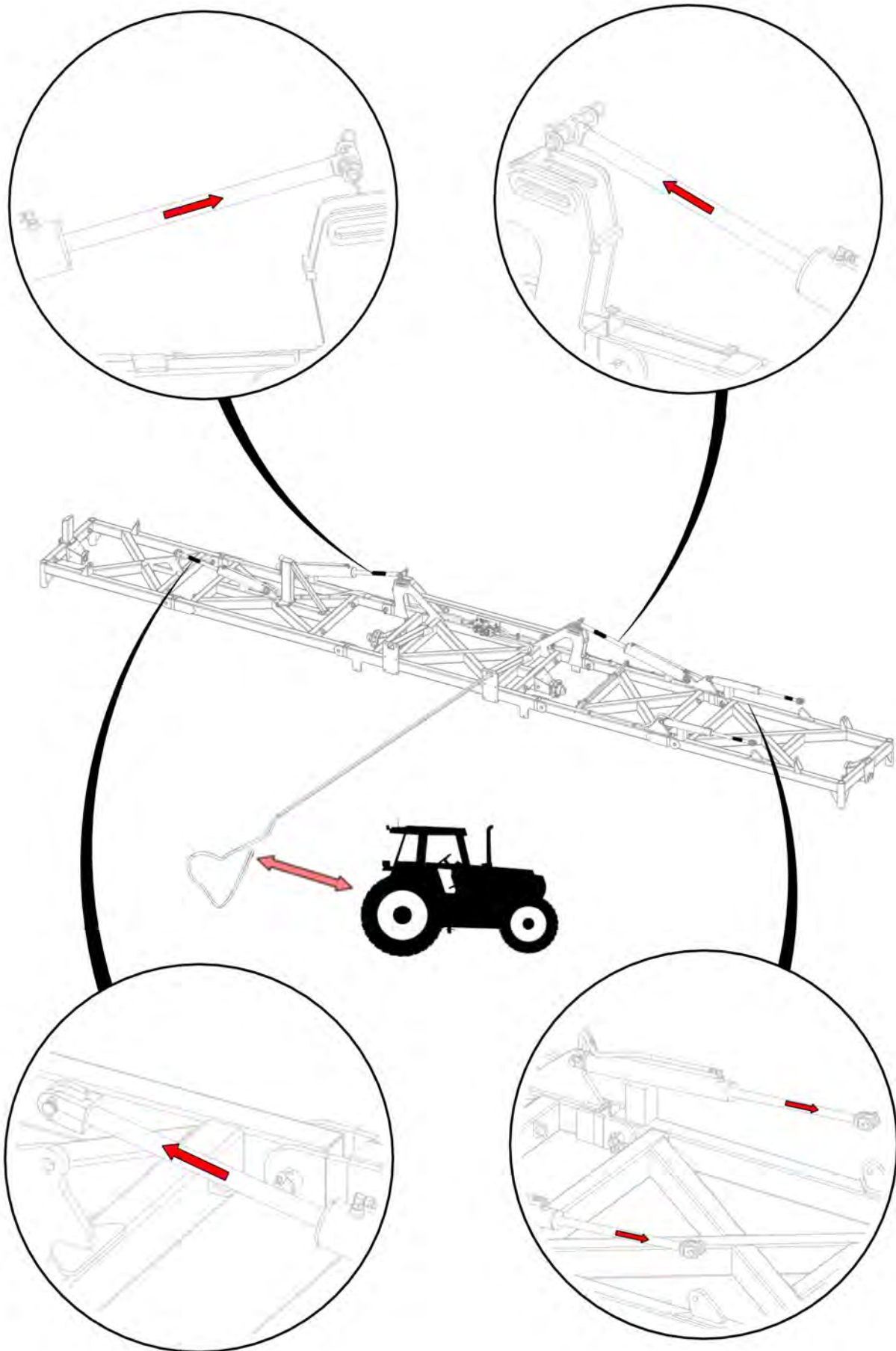

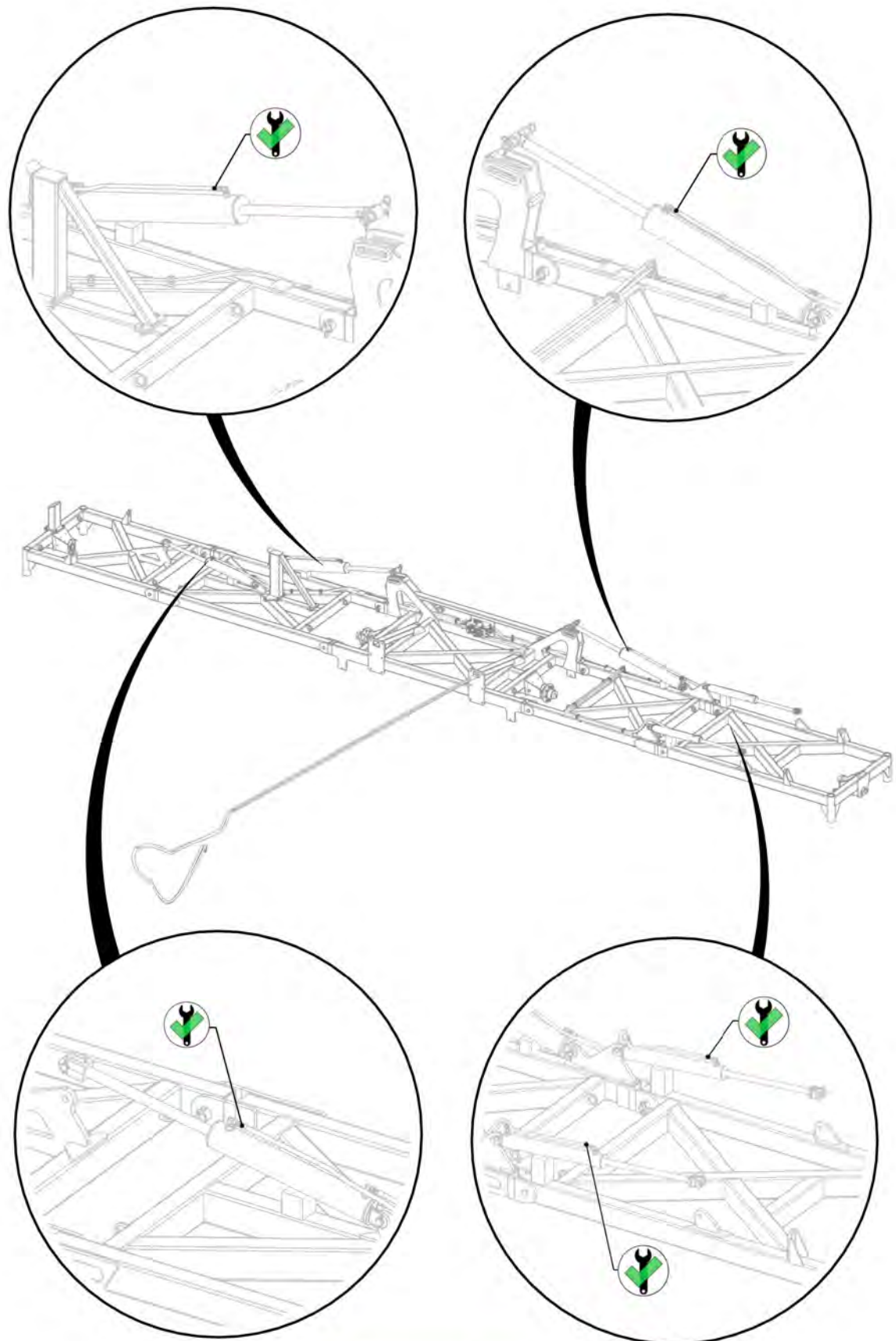

Tighten retract fittings

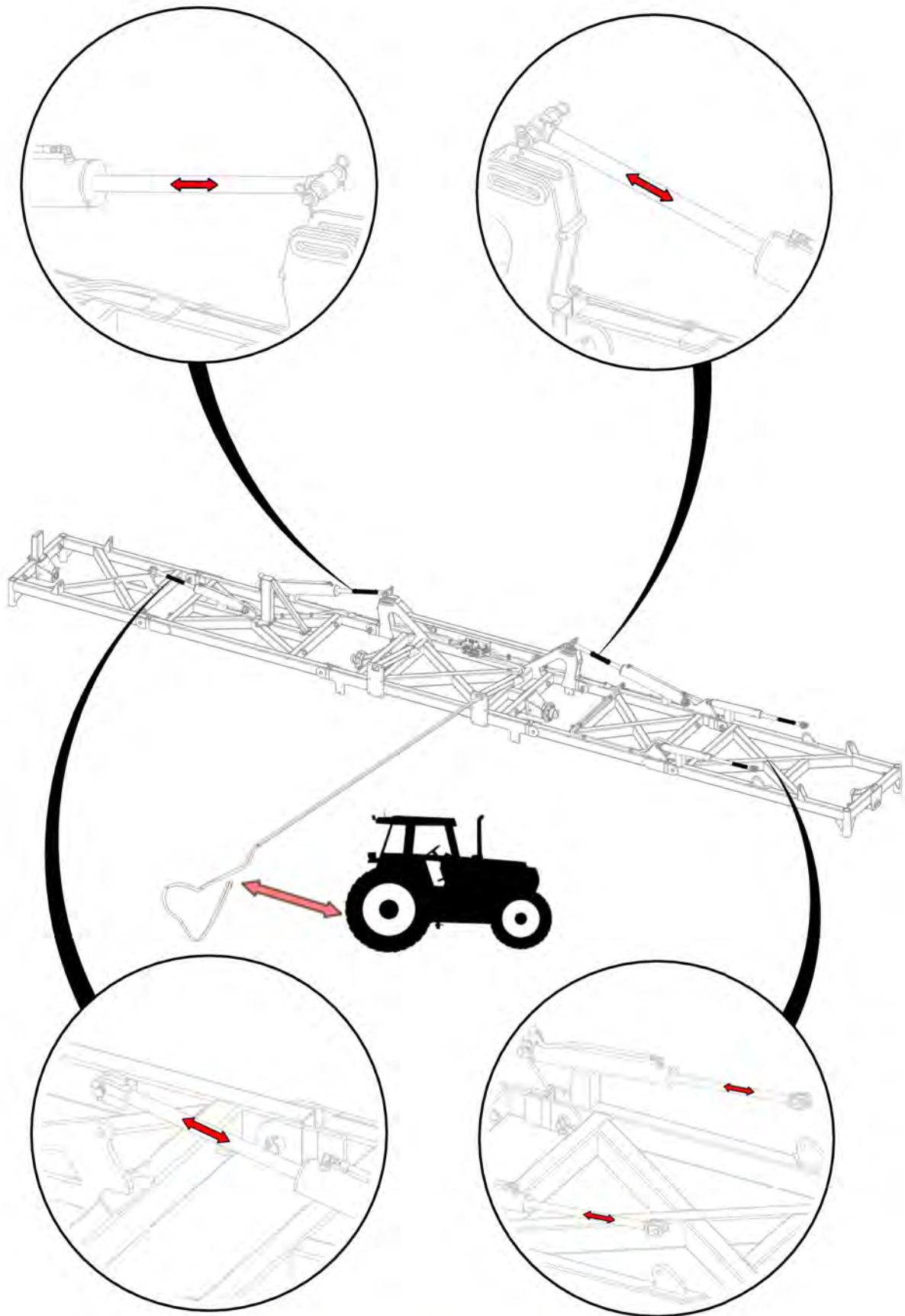

Cycle cylinders to expel air from system

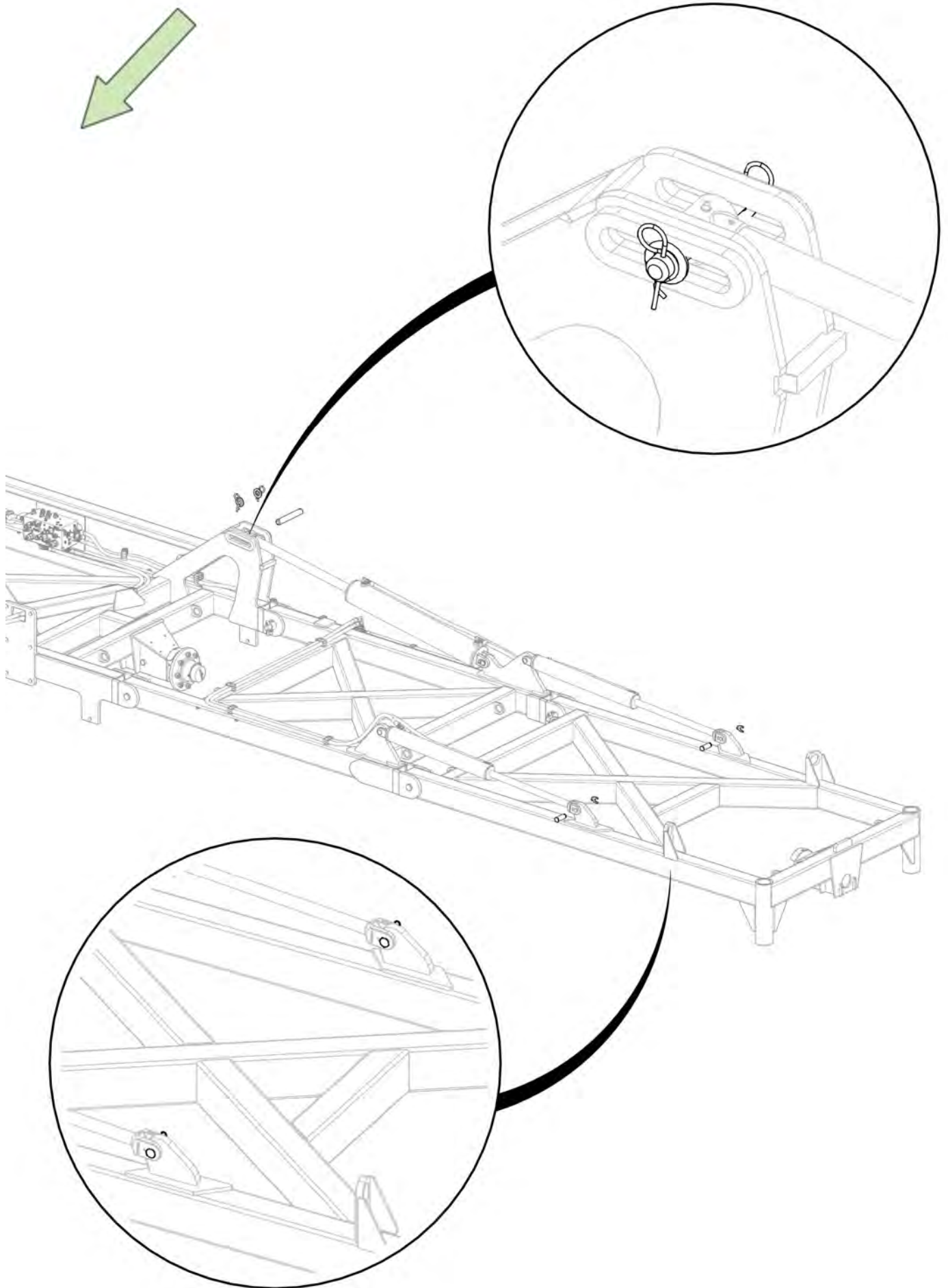

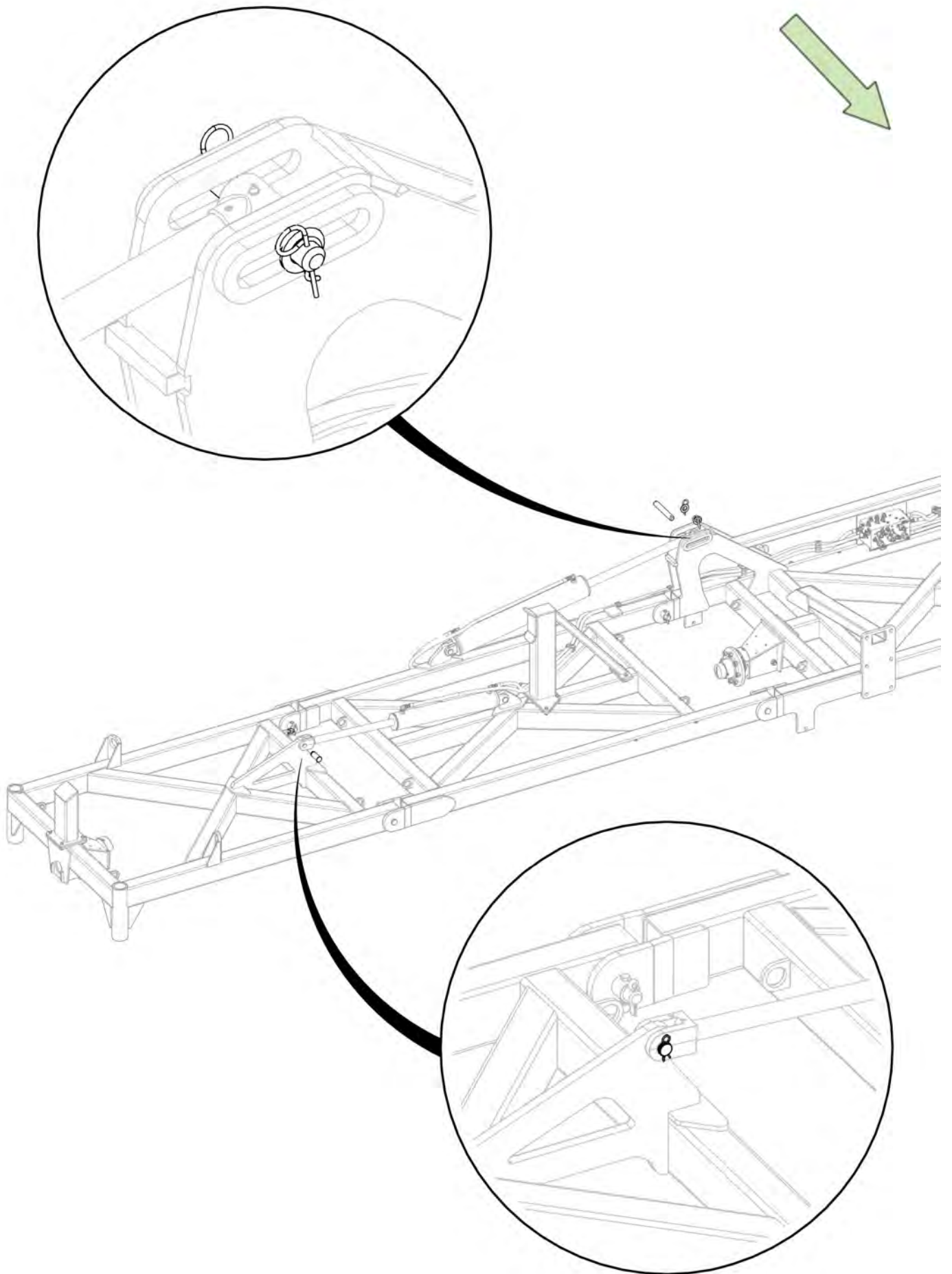

Item No.	Description	Number	Qty
1	M24 x 80 Class 8.8 ZP Bolt	0211-2480	12
2	Washer Flat M24	0231-F24	24
3	Nyloc Nut M24	0221-NYL24	12
4	40' Front A Frame	0840-02-2	1

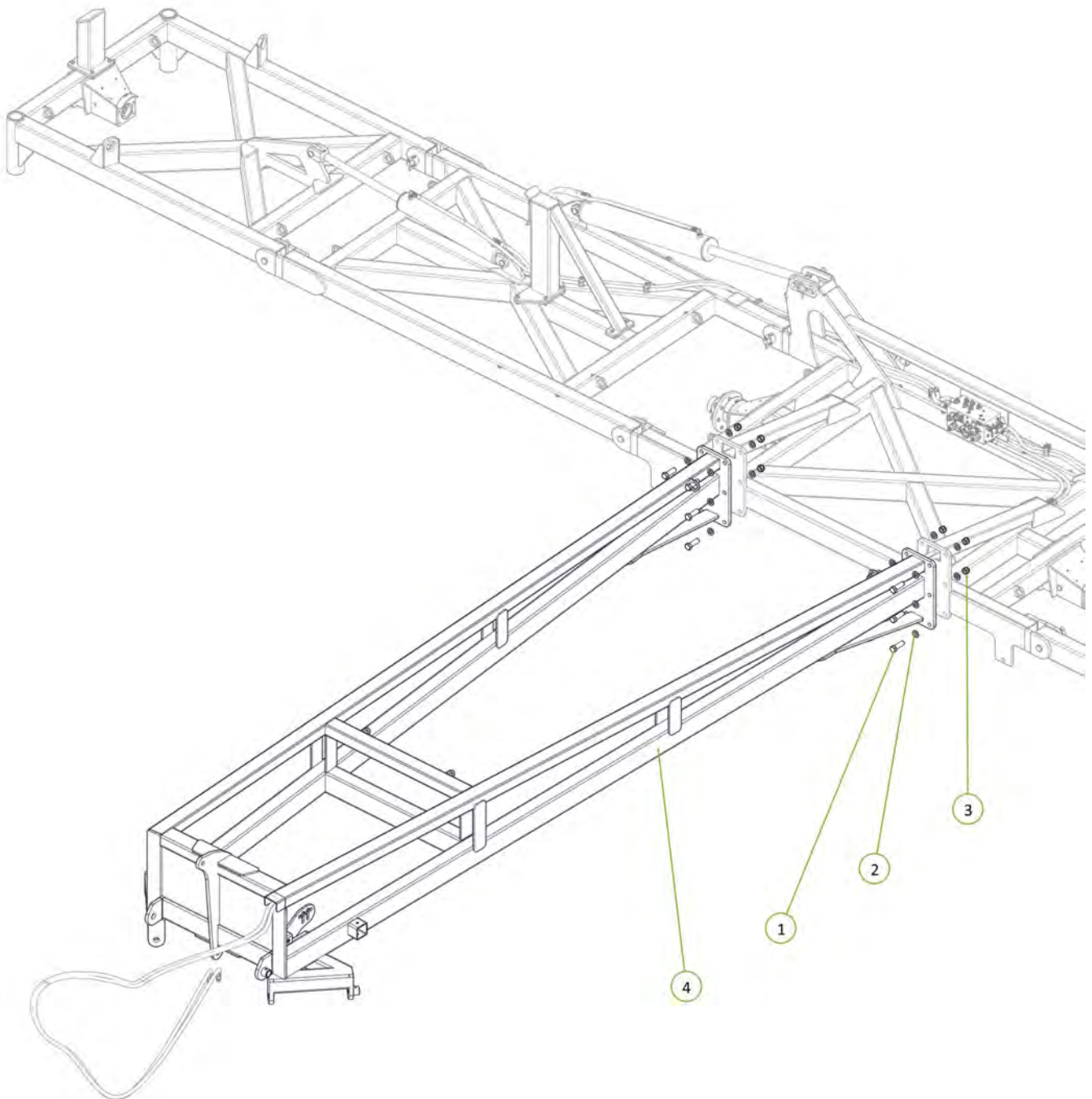

Item No.	Description	Number	Qty
1	2.75"R 6 Tonne 8 on 8" PCD Hub & Stub Complete	0733-SH27596880	1
2	M20 x 170 grade 8.8 ZP Bolt	0211-20170	1
3	Nyloc Nut M20	0221-NYL20	1

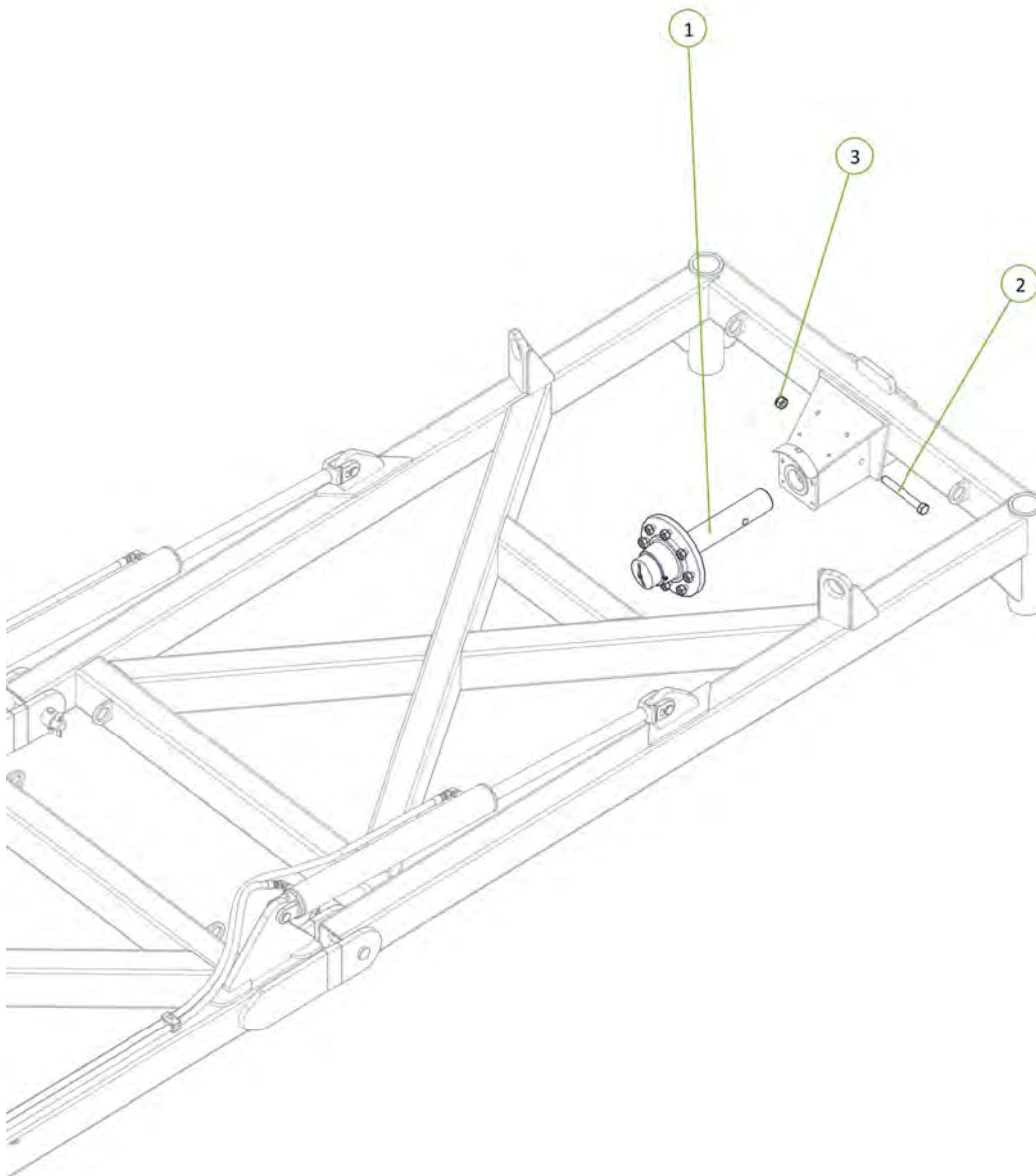

Item No.	Description	Number	Qty
1	2.75"R 6 Tonne 8 on 8" PCD Hub & Stub Complete	0733-SH27596880	1
2	M20 x 170 grade 8.8 ZP Bolt	0211-20170	1
3	Nyloc Nut M20	0221-NYL20	1

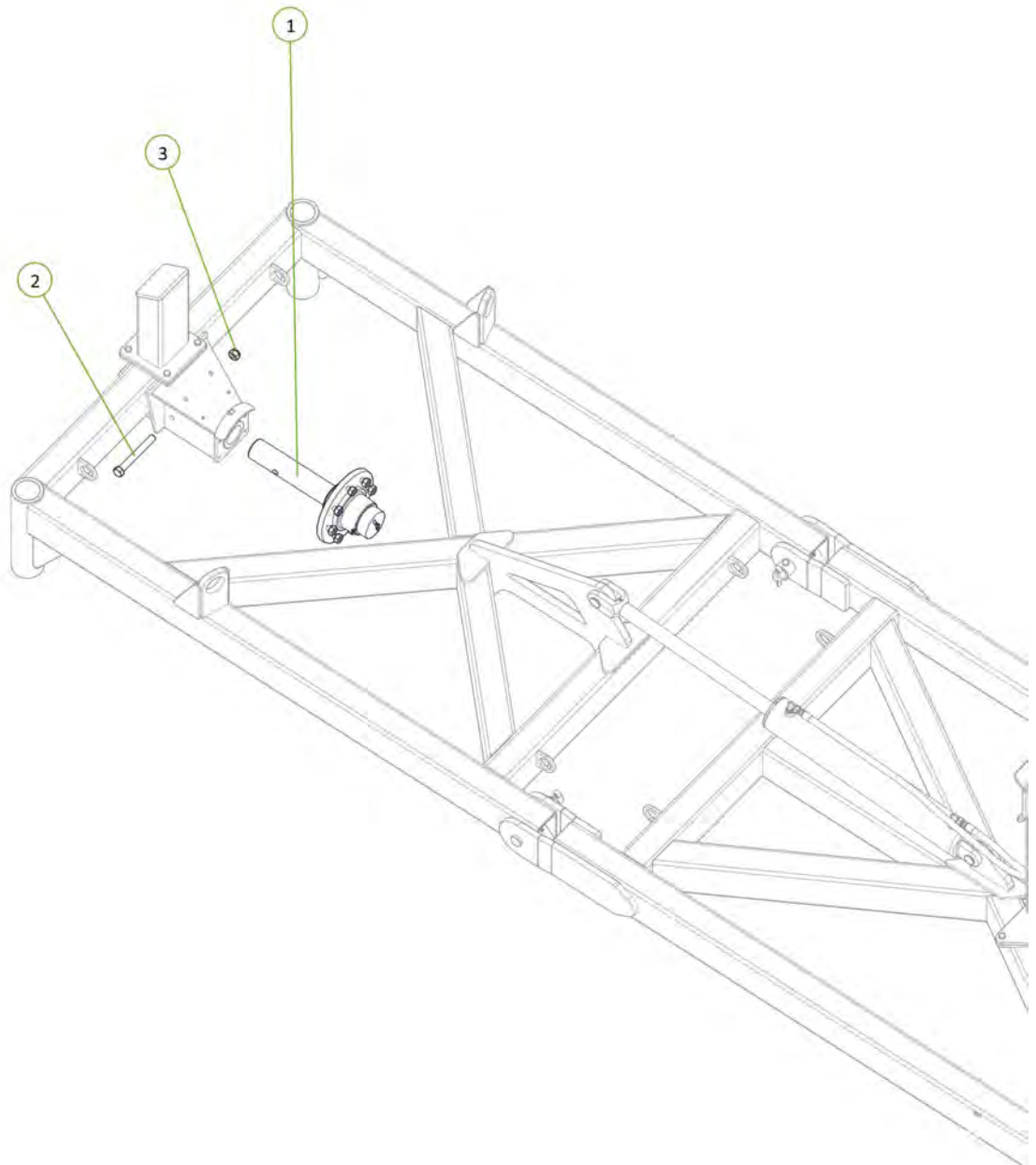

Item No.	Description	Number	Qty
1	15.0/70-18 Tyre On 8 on 8" PCD Rim	0751-15.0-70-18TR	4

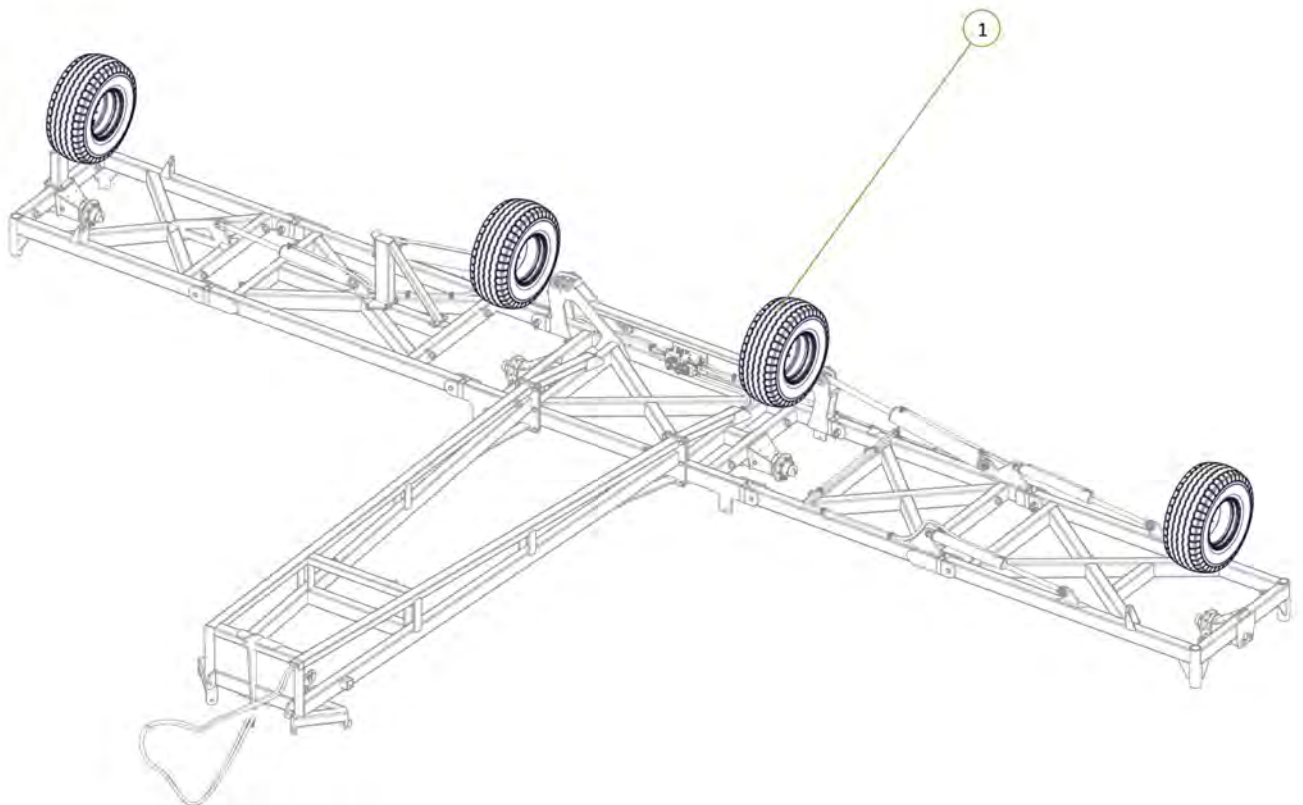

Torque wheel nuts to 100ft-lb / 140Nm

Item No.	Description	Number	Qty
1	Tapered T-Bar Drawbar	1510-08-2	1
2	Drawbar Pivot Pin	0801-10-13-970	1
3	Drawbar Pivot Bush	0801-B423838	4
4	M12 x 80 Class 8.8 ZP Bolt	0211-1280	1
5	Nyloc Nut M12	0221-NYL12	1
6	Cotter Pin M13 x 63	0261-PINC1363	1

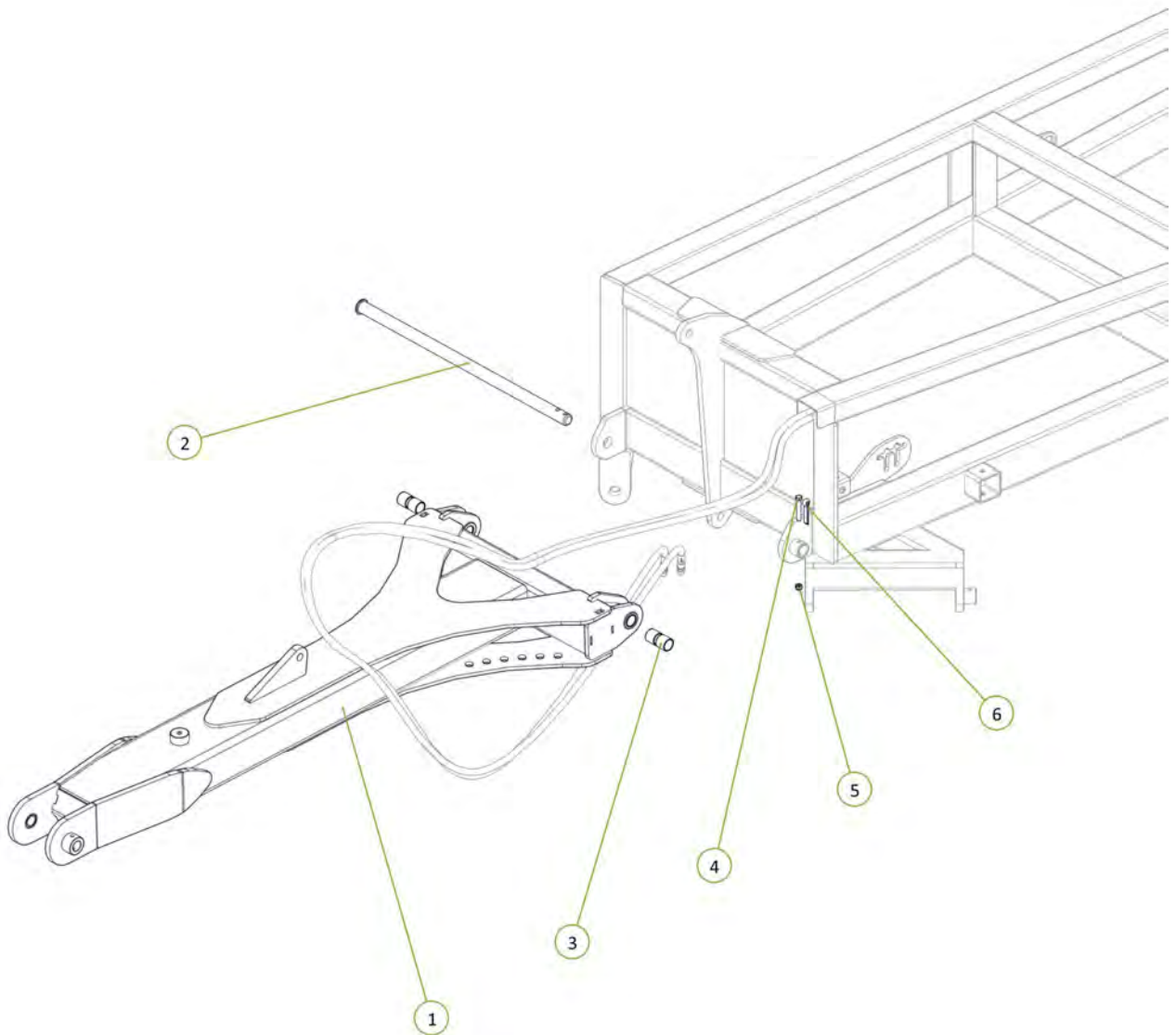

Item No.	Description	Number	Qty
1	Tow Hitch	0810-09	1
2	35 ID x 50mm DX Bush	0113-MB3550DX	2
3	M12 x 90 Class 8.8 ZP Bolt	0211-1290	2
4	Nyloc Nut M12	0221-NYL12	2
5	Grease Nipple 1/4" UNF 45°	0181-GN1/445	2
6	Tow Hitch Pivot Pin	0801-10-14	1

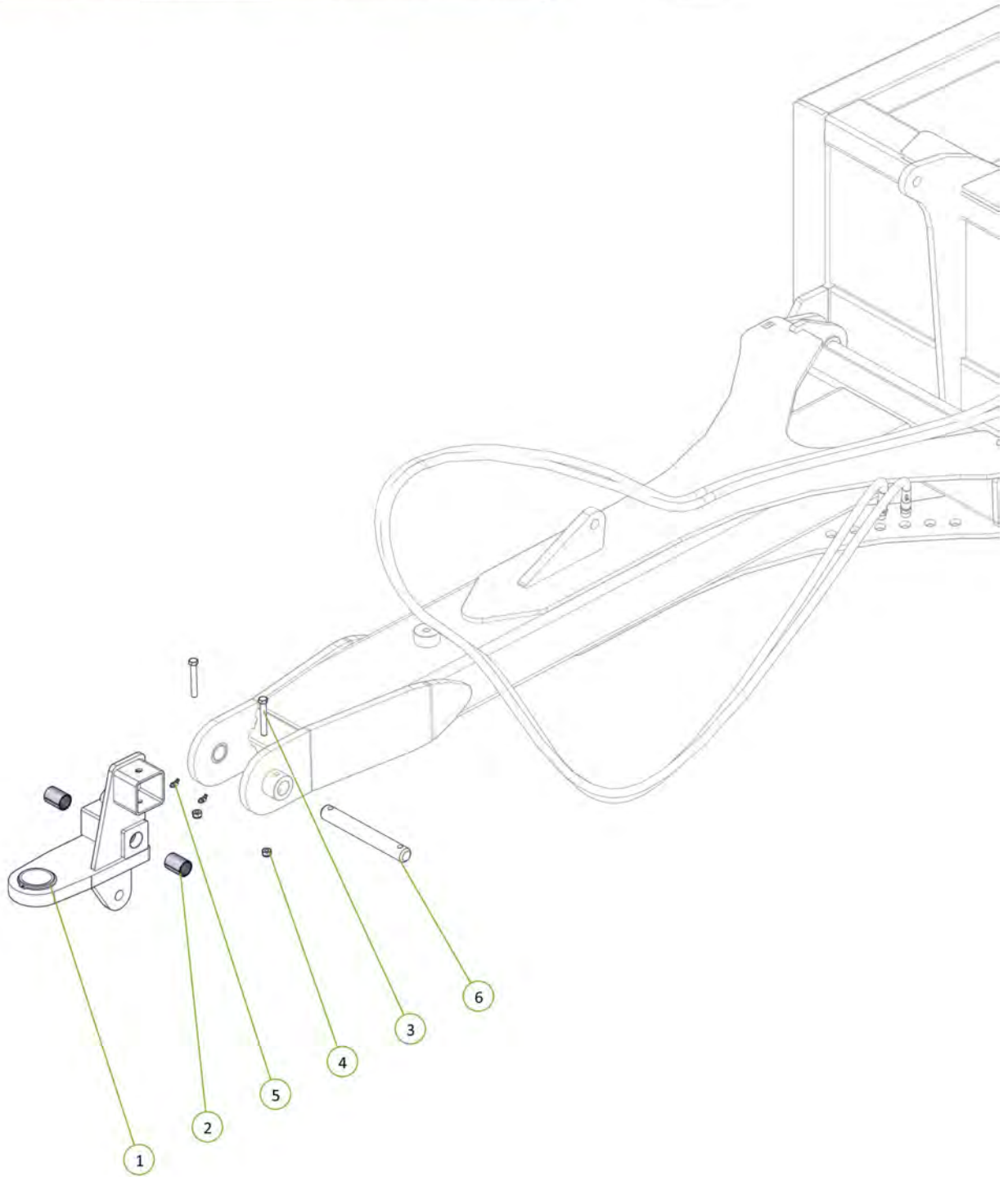
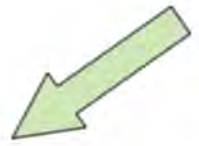

Item No.	Description	Number	Qty
1	Parallel Arm	0810-58	1
2	Clevis Pin 25mm x 75mm	0801-KE0307-1	2
3	Washer Flat M24	0231-F24	2
4	Cotter Pin M5 x 50	0261-PINC550	2

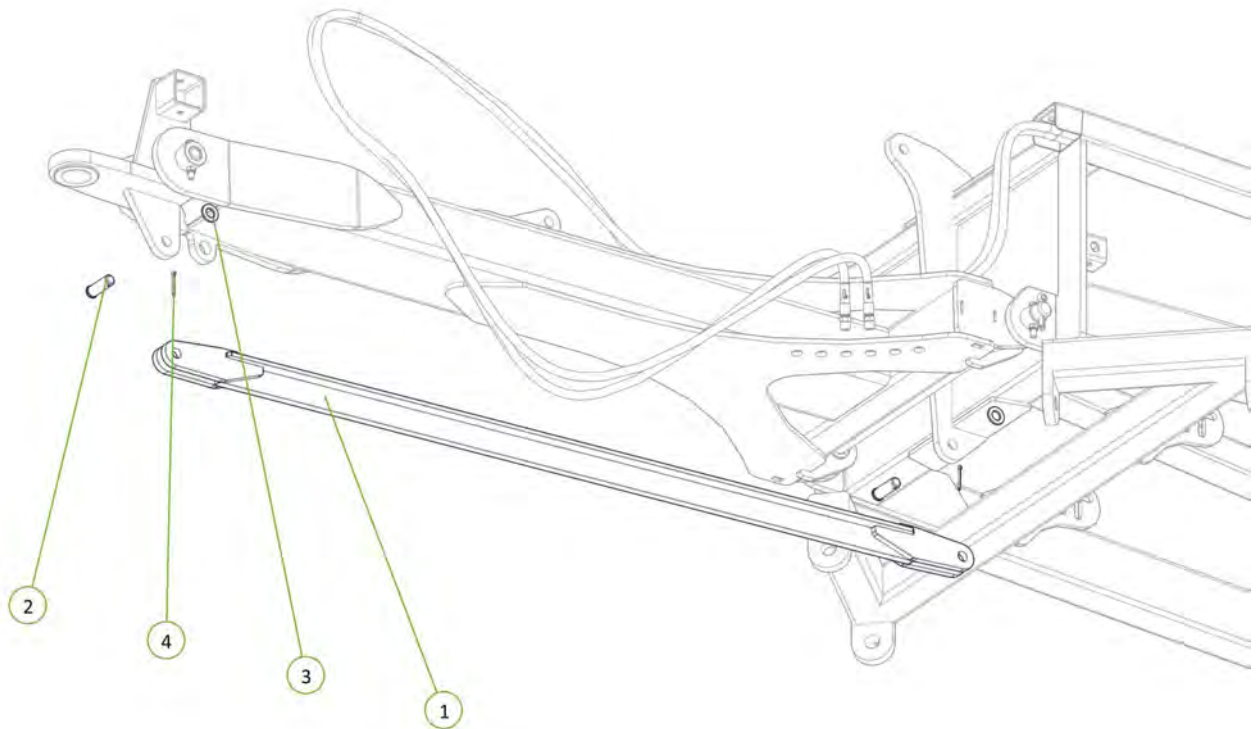

Item No.	Description	Number	Qty
1	3" Bore x 12" Stroke 1.5" Rod Extended Hydraulic Cylinder	0311-312EXT	1

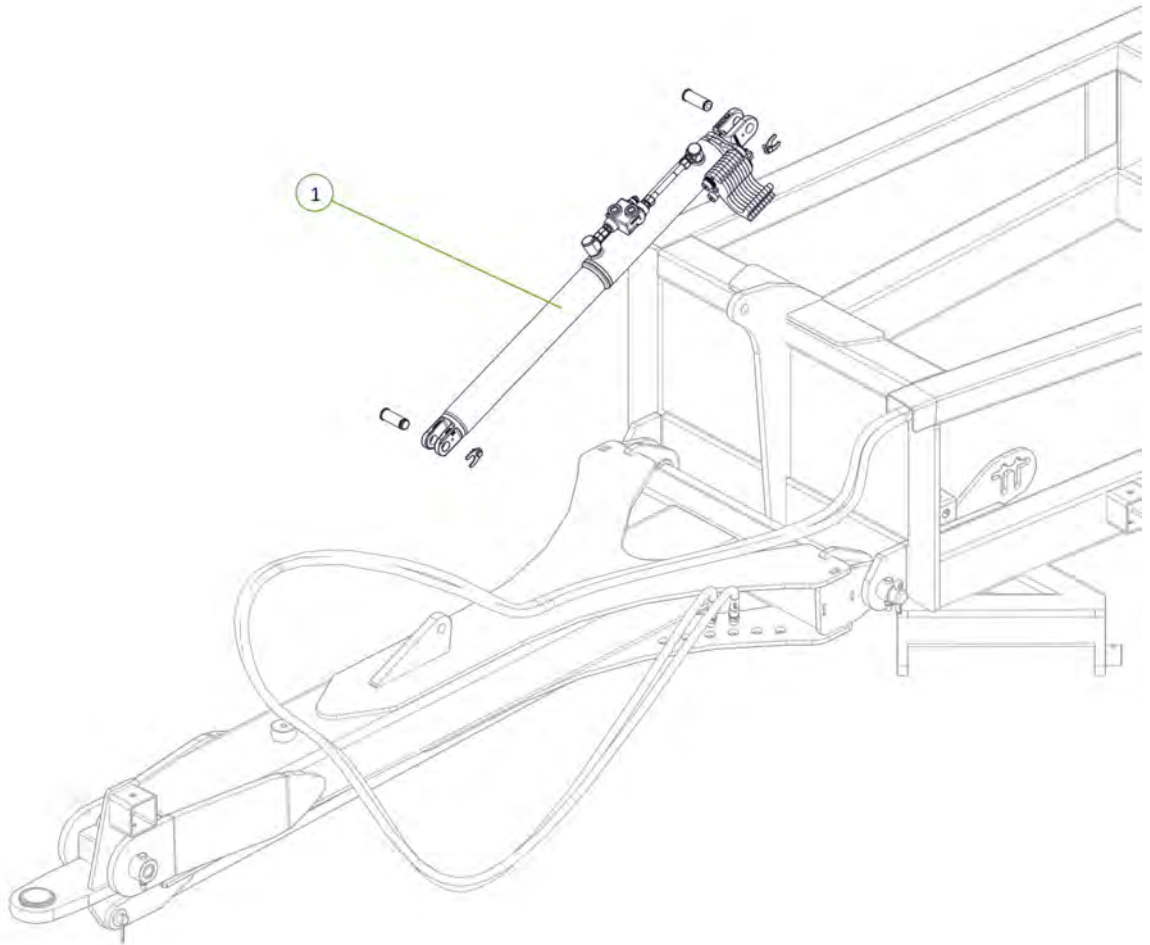

Item No.	Description	Number	Qty
1	Heavy Duty Jack	0801-SAK45B	1
2	Jack Pin	0801-B3077	1

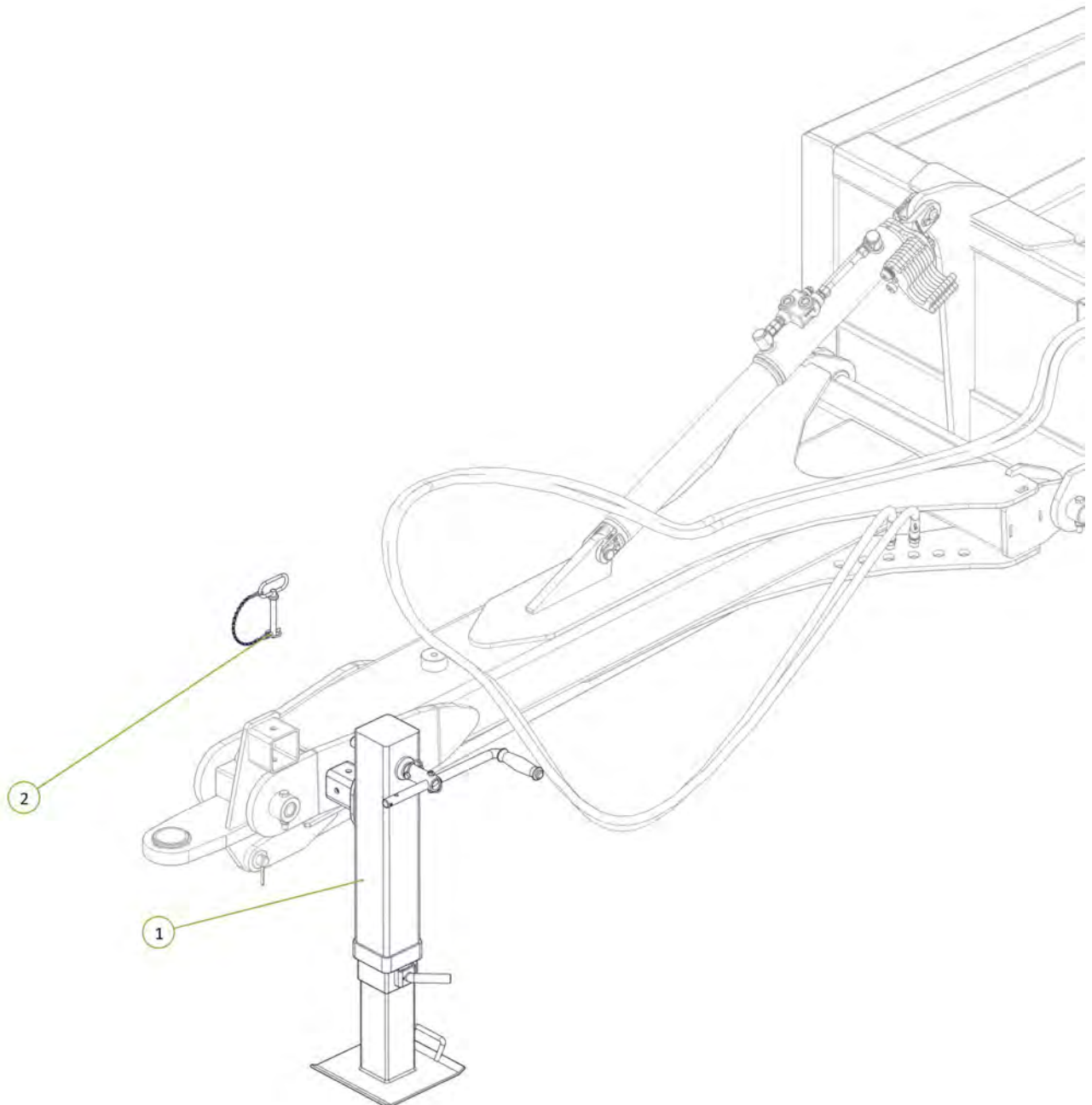

Item No.	Description	Number	Qty
1	Hose Post Spring	1601-CDB-00-0012	1
2	M16 x 35 grade 8.8 zp Bolt	0211-1635	1
3	Washer Spring M16	0231-S16	1
4	Washer Flat M16	0231-F16	1

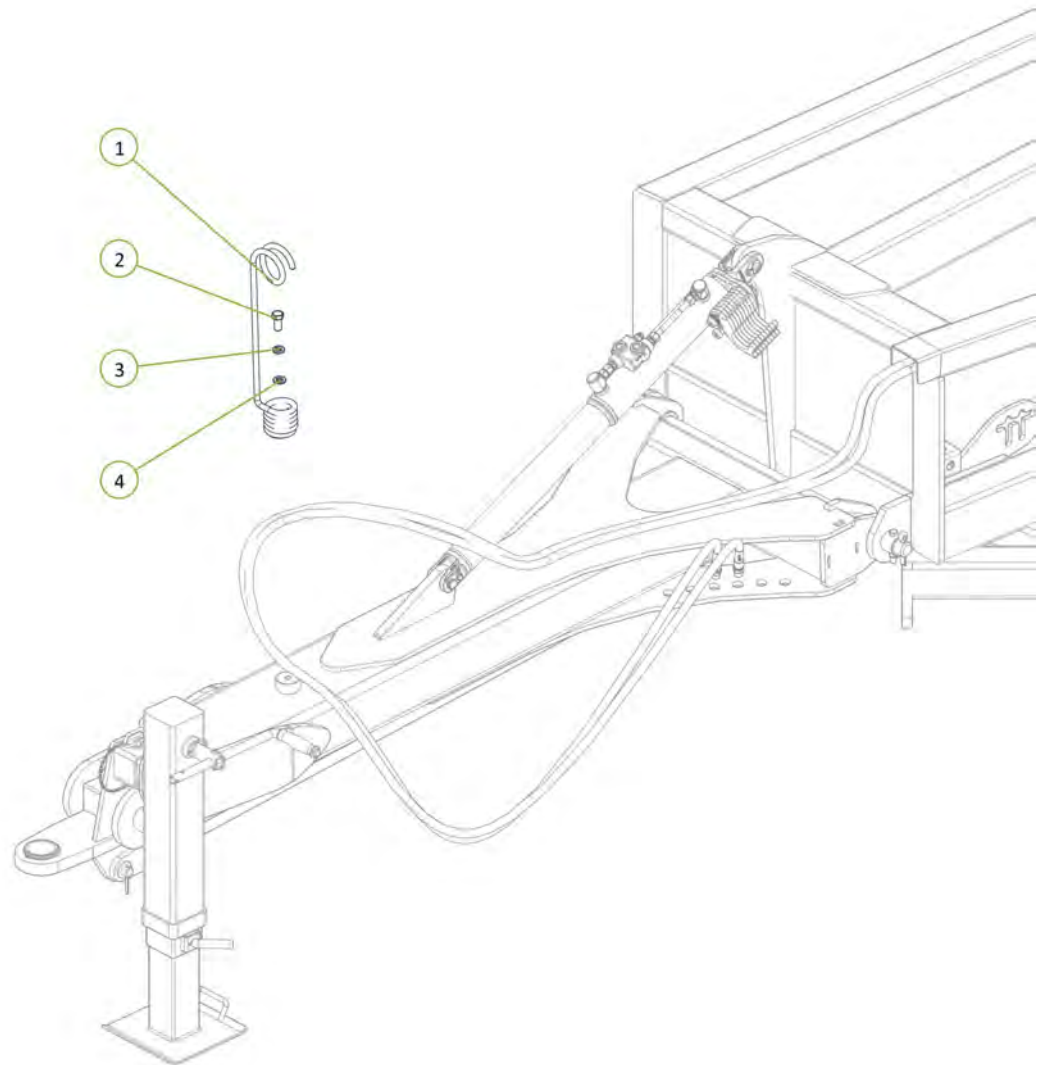
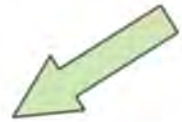

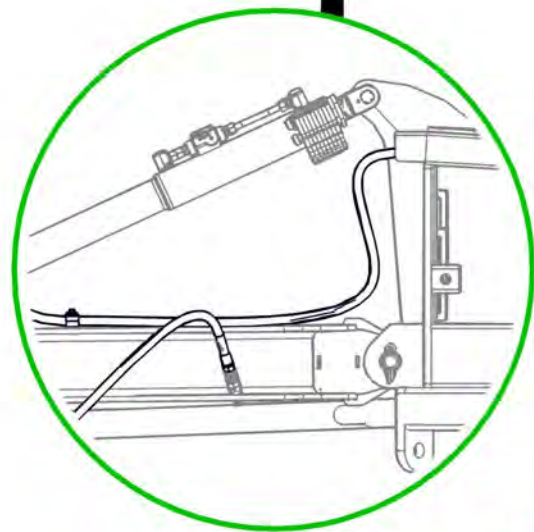
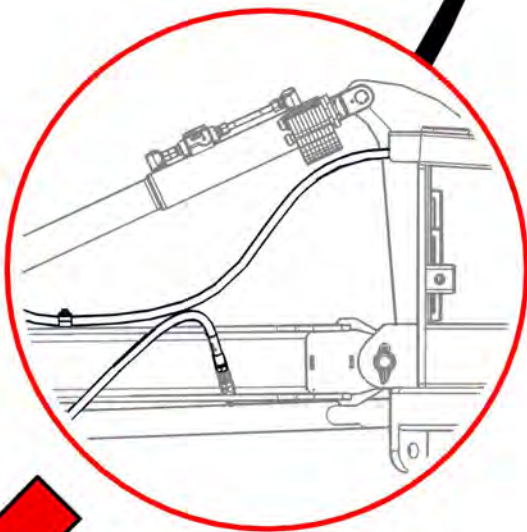
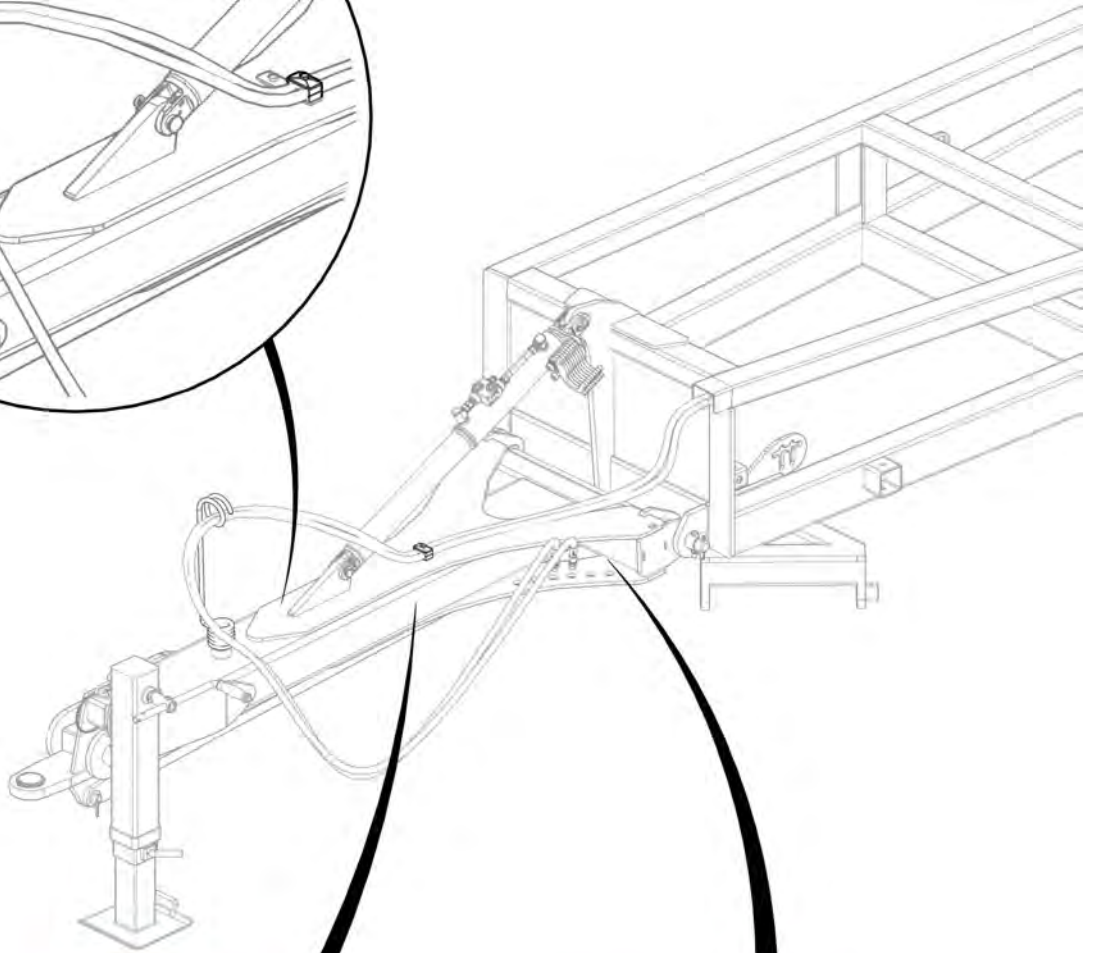
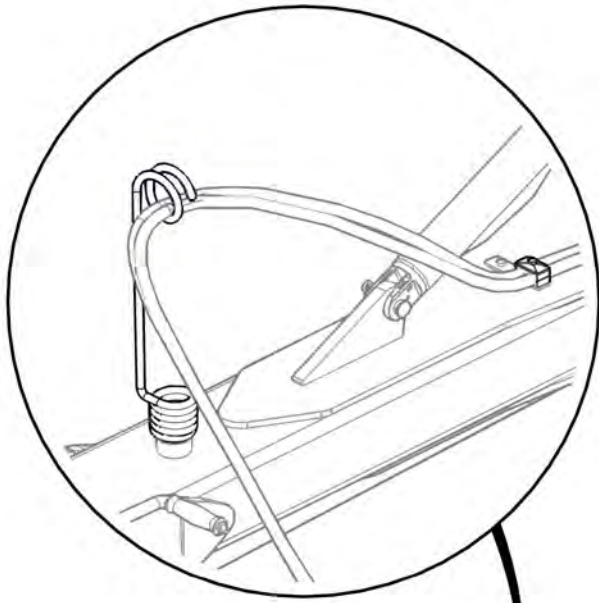

Item No.	Description	Number	Qty
1	Tractor to Sequence Valve EXT2 Port Fitted with Yellow Extend Decal	PH40-01-YE-EXT2	1
2	Tractor to Sequence Valve RCT2 Port Fitted with Yellow Retract Decal	PH40-01-YR-RCT2	1

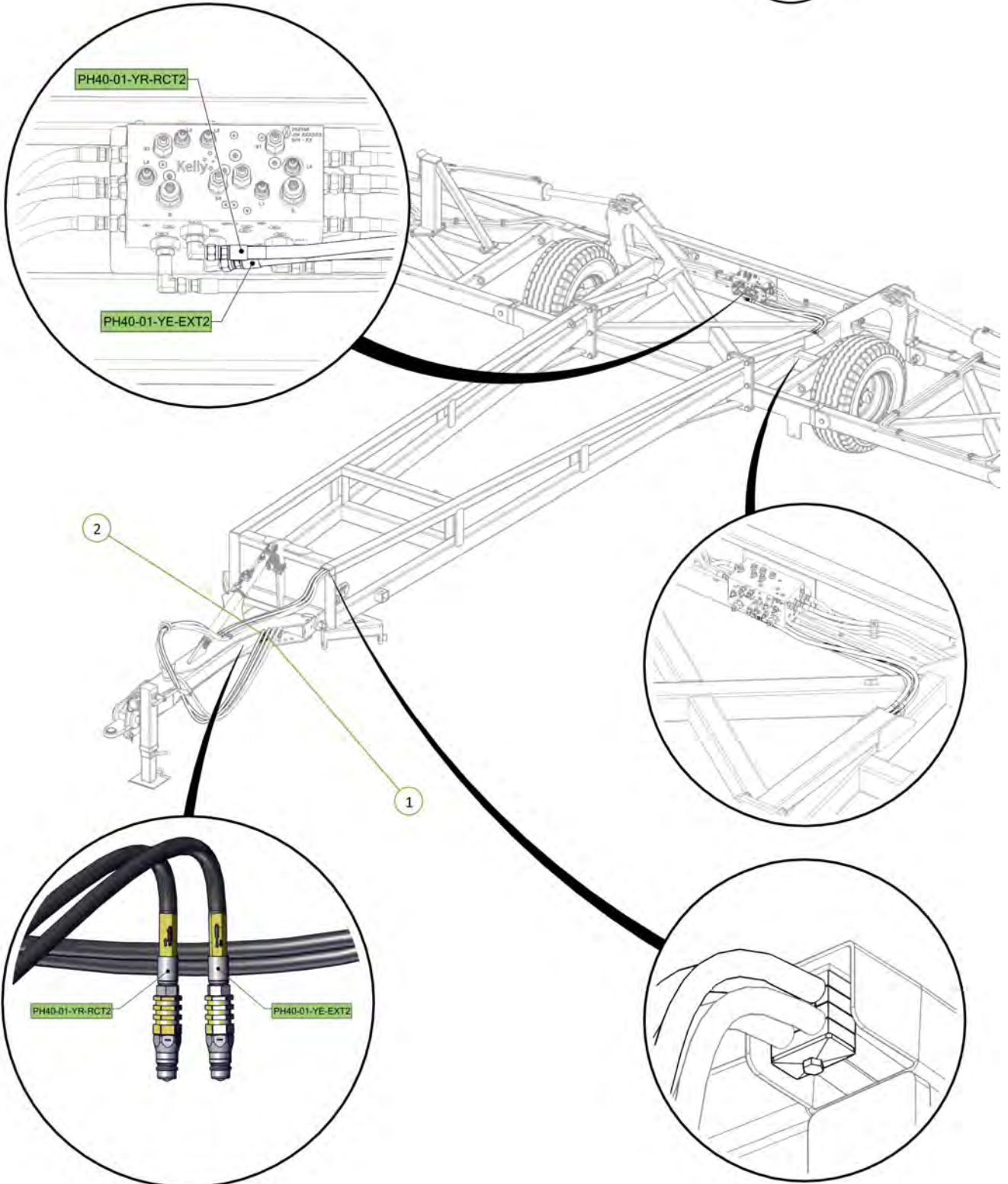

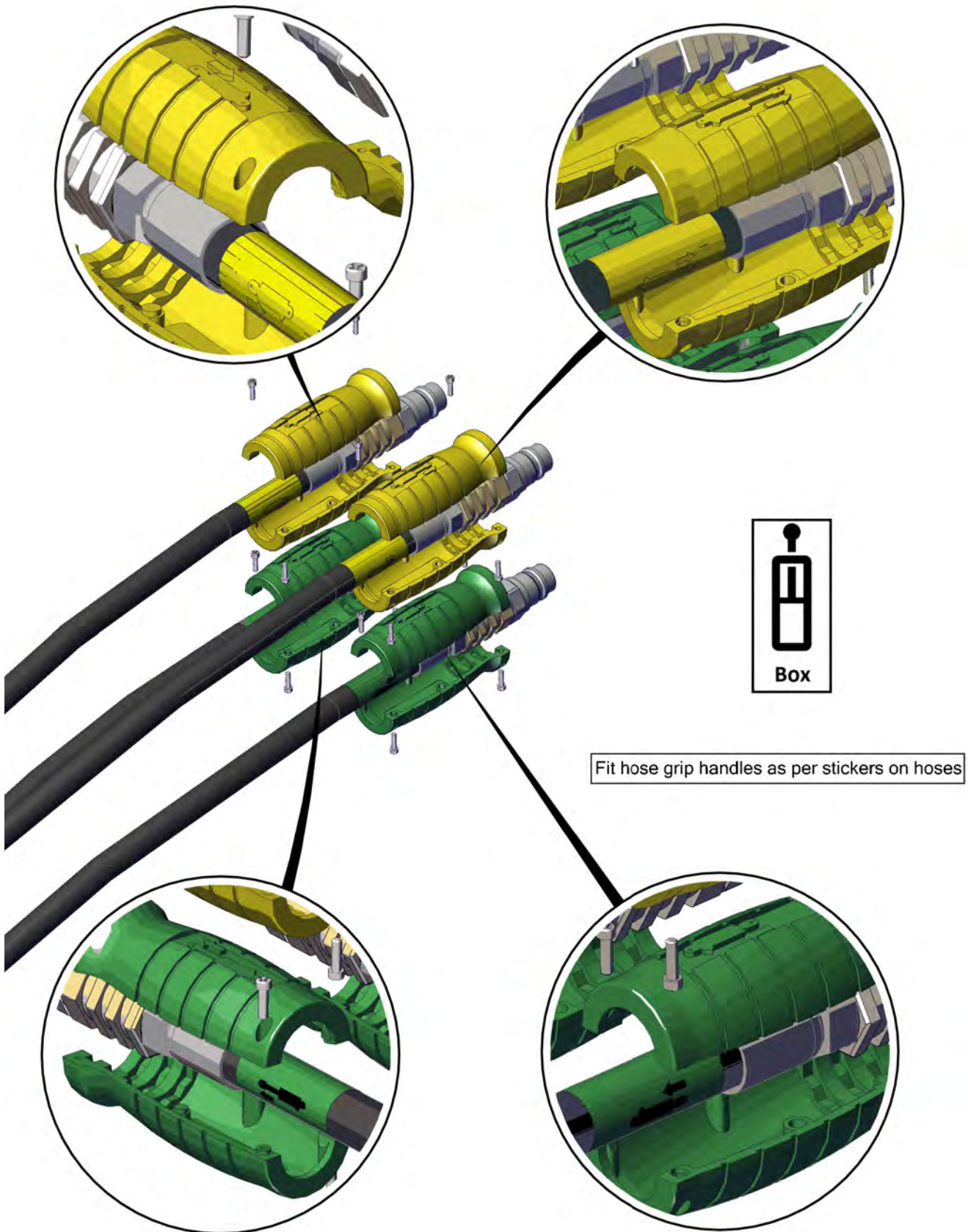

Item No.	Description	Number	Qty
1	3/4" JIC Male 3/4" UN O Ring Male 90° Elbow	0323-S91-1212	2

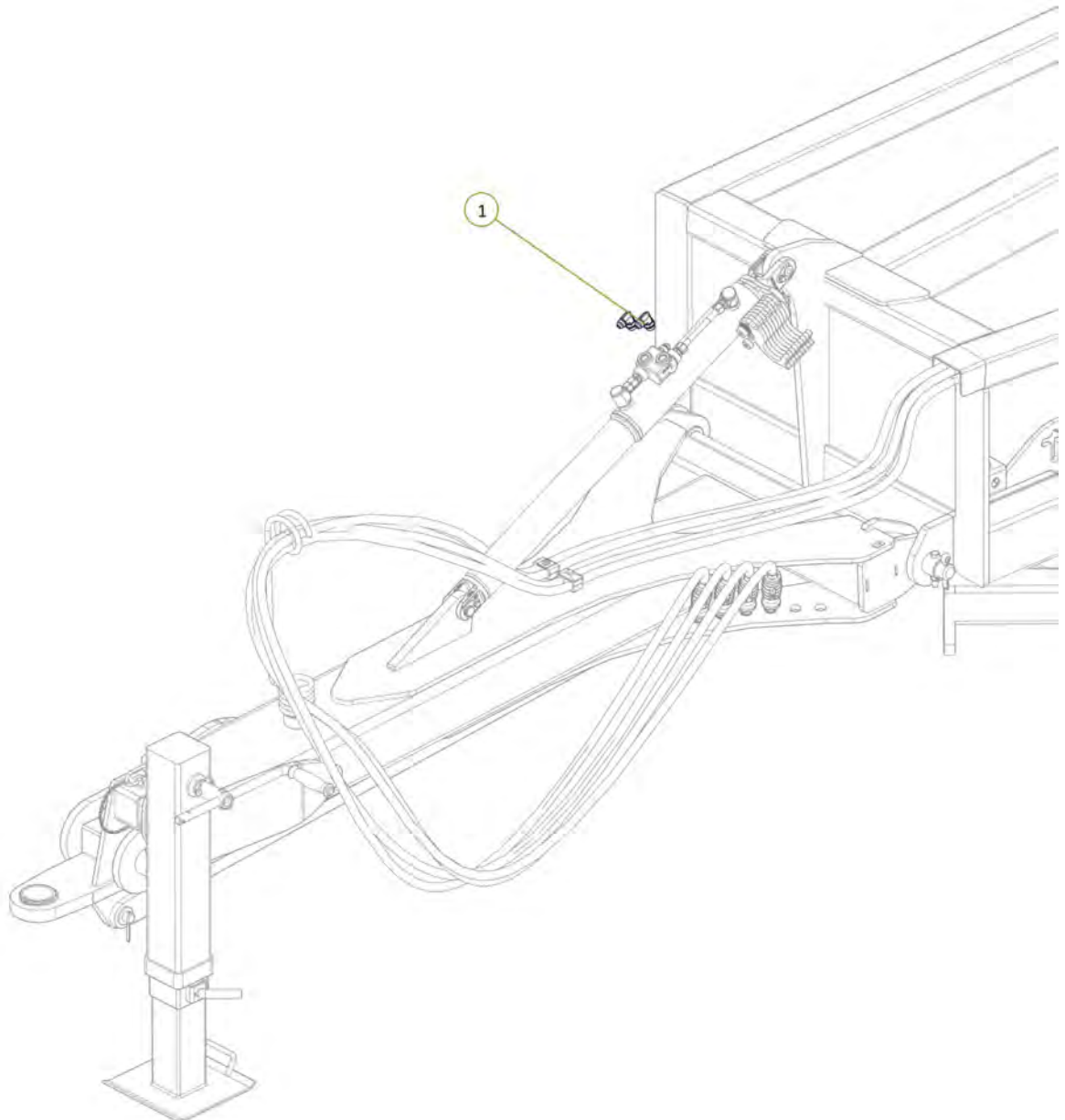

Item No.	Description	Number	Qty
1	Tractor to Front lift Cylinder Extend Port Fitted with Blue Extend Grip	PH40-02-BE-EXT	1
2	Tractor to Front Lift Cylinder Retract Port Fitted with Blue Retract Grip	PH40-03-BR-RCT	1

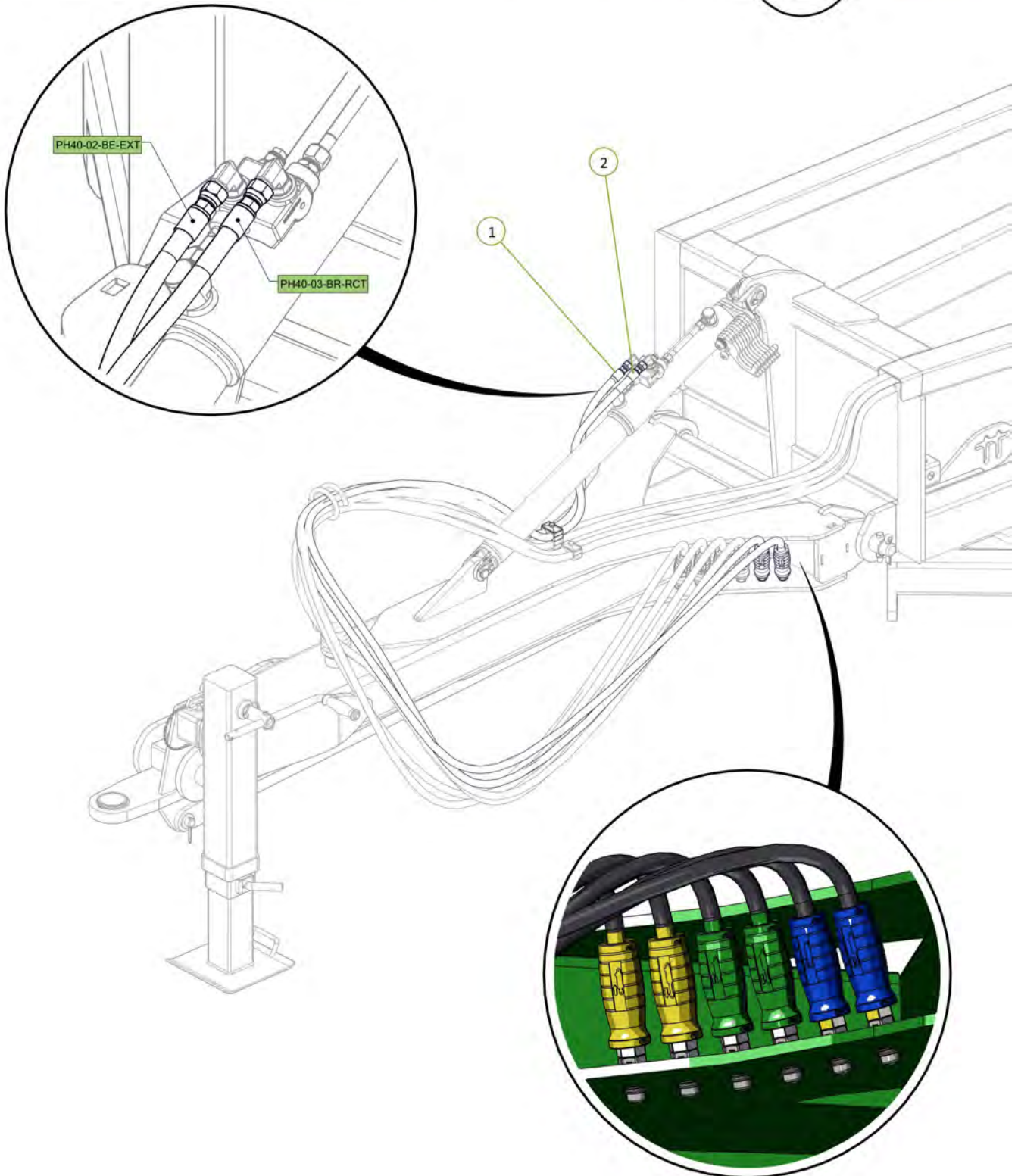

Item No.	Description	Number	Qty
1	40' Rear A-Frame	0840-03-2	1
2	Tail Frame Pivot pin	0801-10-08-175	2
3	M12 x 80 Class 8.8 ZP Bolt	0211-1280	2
4	Nyloc Nut M12	0221-NYL12	2
5	Cotter Pin M13 x 63	0261-PINC1363	2

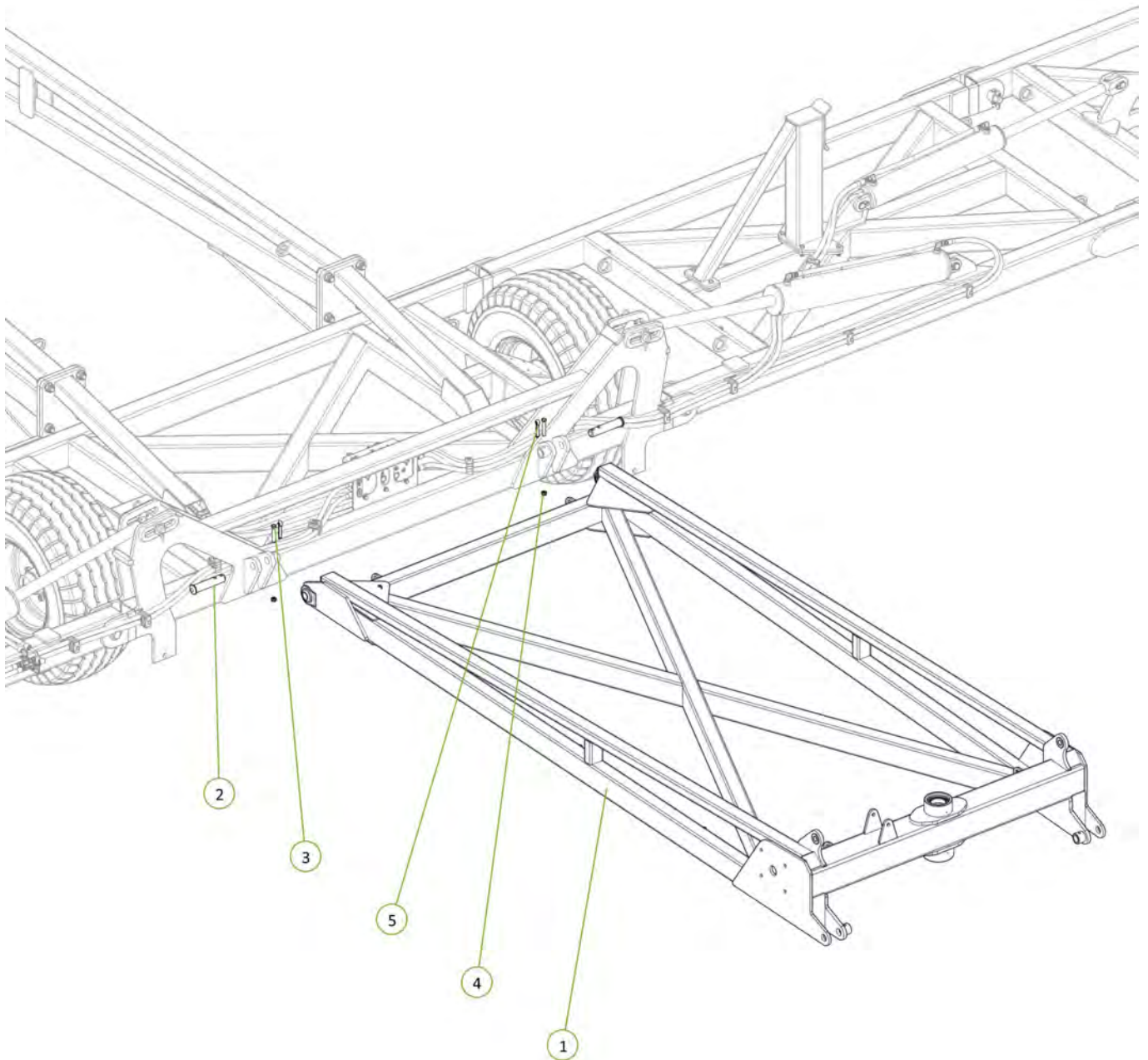

Item No.	Description	Number	Qty
1	70mm Jockey Wheel (Sleeved)	1610-12-70	1
2	Plain Spherical Bearing 70mm	0113-GE70DO-2RS	2
3	Circlip Internal 105mm	0171-J105	2
4	Circlip External 70mm	0172-D1400-0700APP	1
5	Grease Nipple 1/4" UNF 45°	0181-GN1/445	2
6	TC Seal 90mm x 125mm x 13mm	0121-TC12681	1

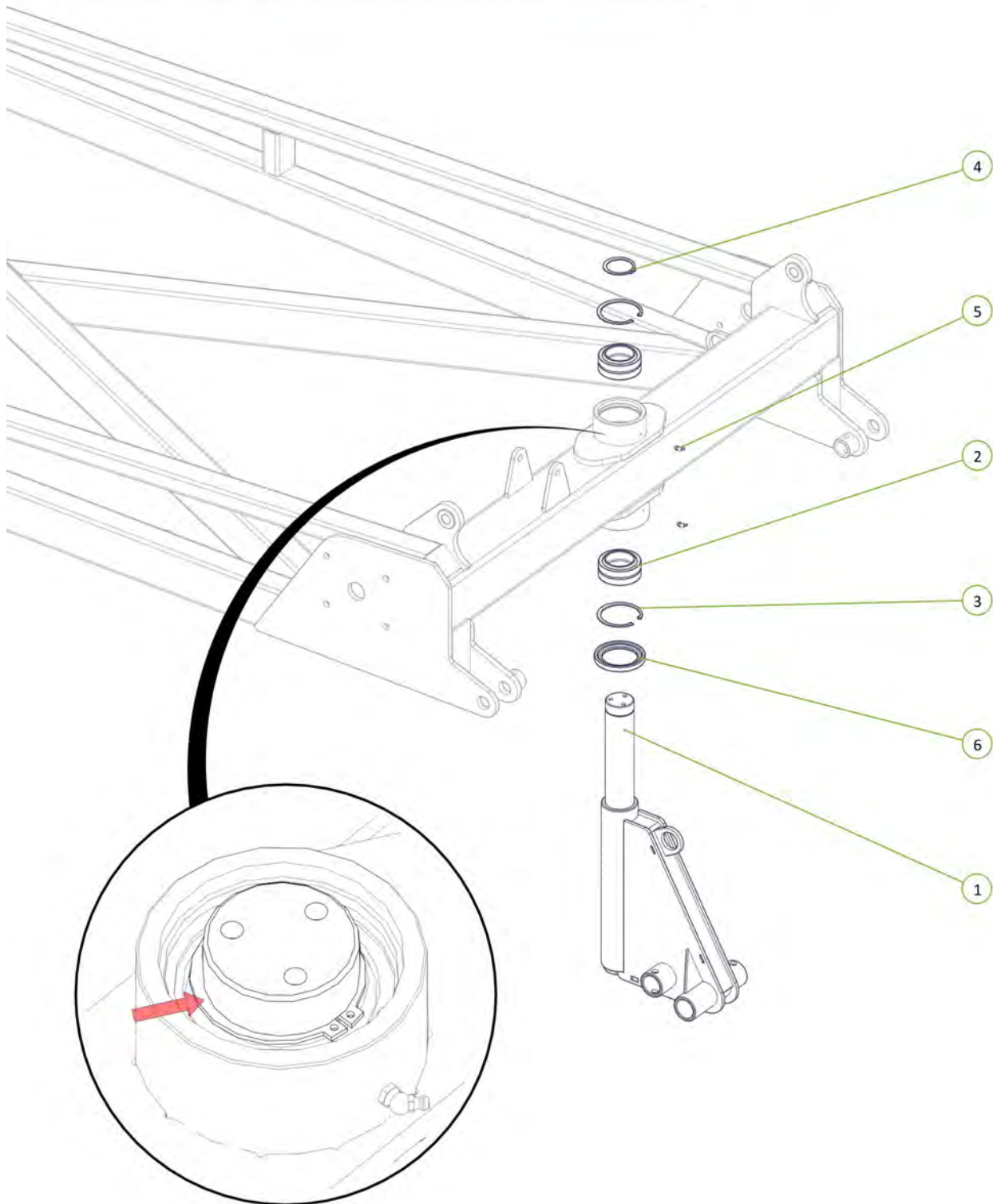
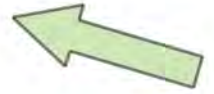

Item No.	Description	Number	Qty
1	Brake Disc	1600-405	1
2	Wheel Stud One Piece M12 x 1.75	0216-WB1224	3
3	TC Seal 70mm x 110mm x 10mm	0121-TC12654	1

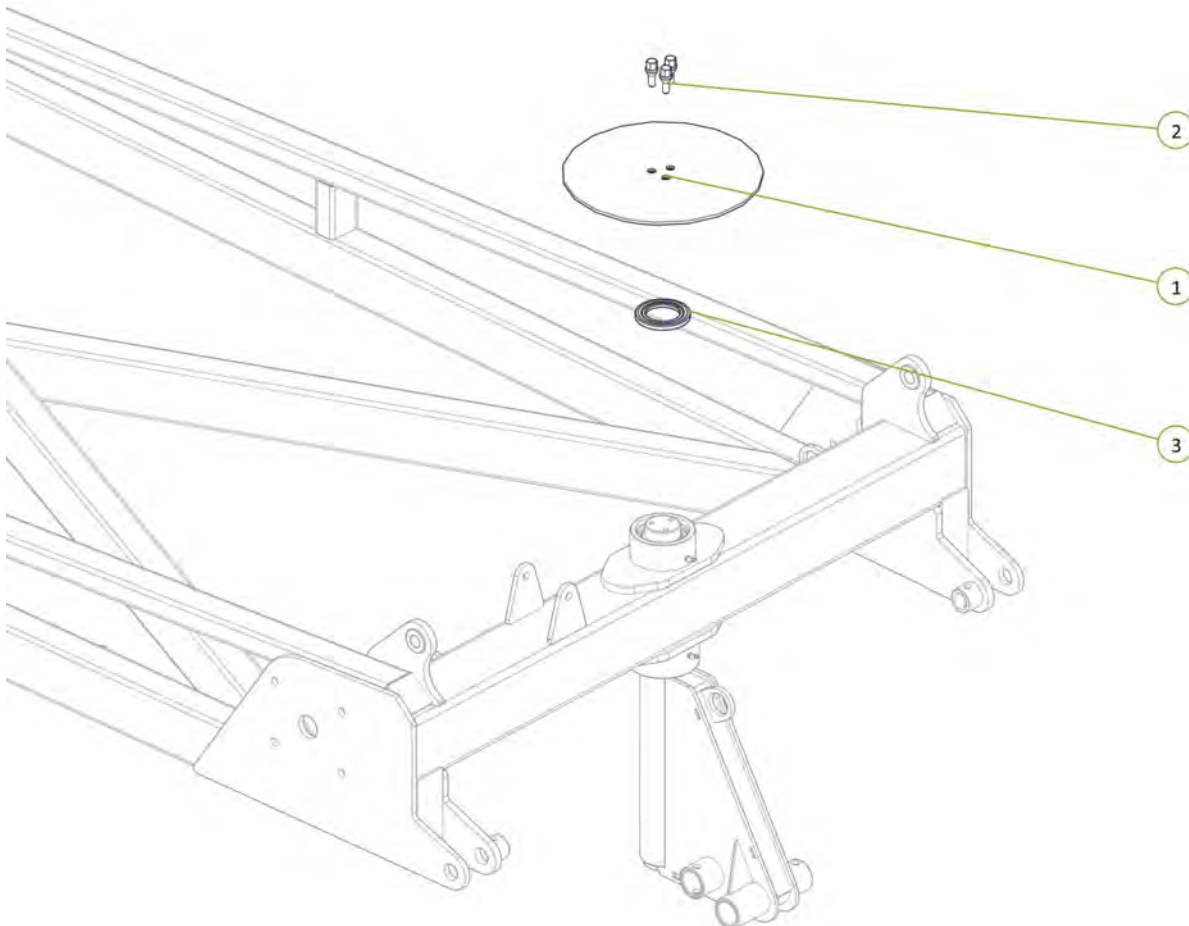
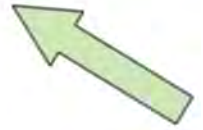

Torque wheel bolts to 65ft-lb / 88nm

Item No.	Description	Number	Qty
1	Jockey Wheel Brake Caliper	0810-12CAL	1
2	Brake Compression Spring	0801-KE009	1
3	Washer Square M16 x 50 x 5	0231-SQ16505	1
4	M16 x 150 Class 8.8 ZP Bolt	0211-16150	1
5	M16 x 160 Class 8.8 ZP Bolt	0211-16160	1
6	Washer Flat M16	0231-F16	2
7	Nyloc Nut M16	0221-NYL16	1
8	Brake Spring Indicator	0800-772	1

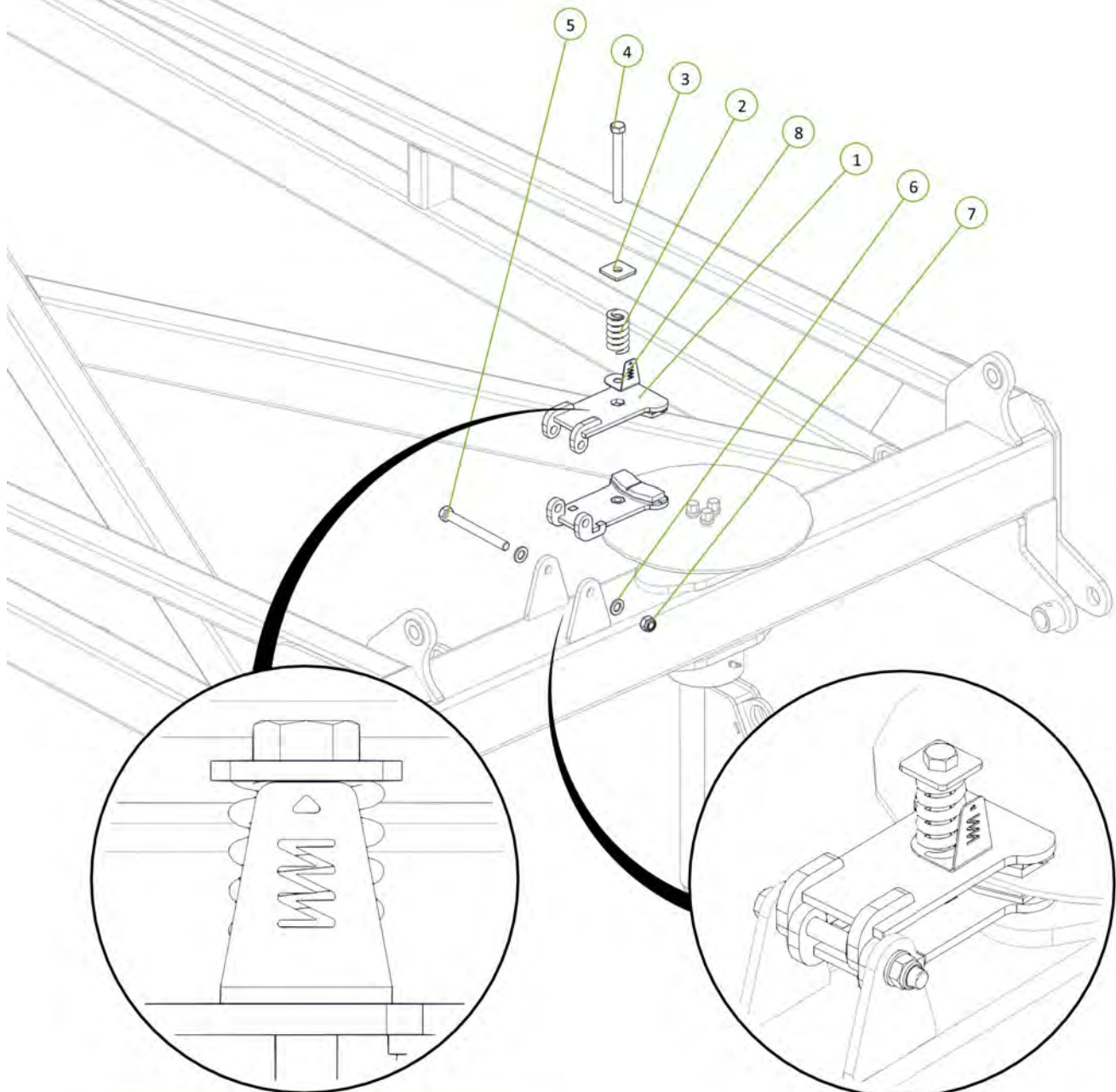

Compress spring to top of indicator as shown

Item No.	Description	Number	Qty
1	Axle 2"R 3T 6 on 6" PCD 330 OHF	0733-K5083T66S	2
2	M16 x 90 Class 8.8 ZP Bolt	0211-1690	2
3	Nyloc Nut M16	0221-NYL16	2

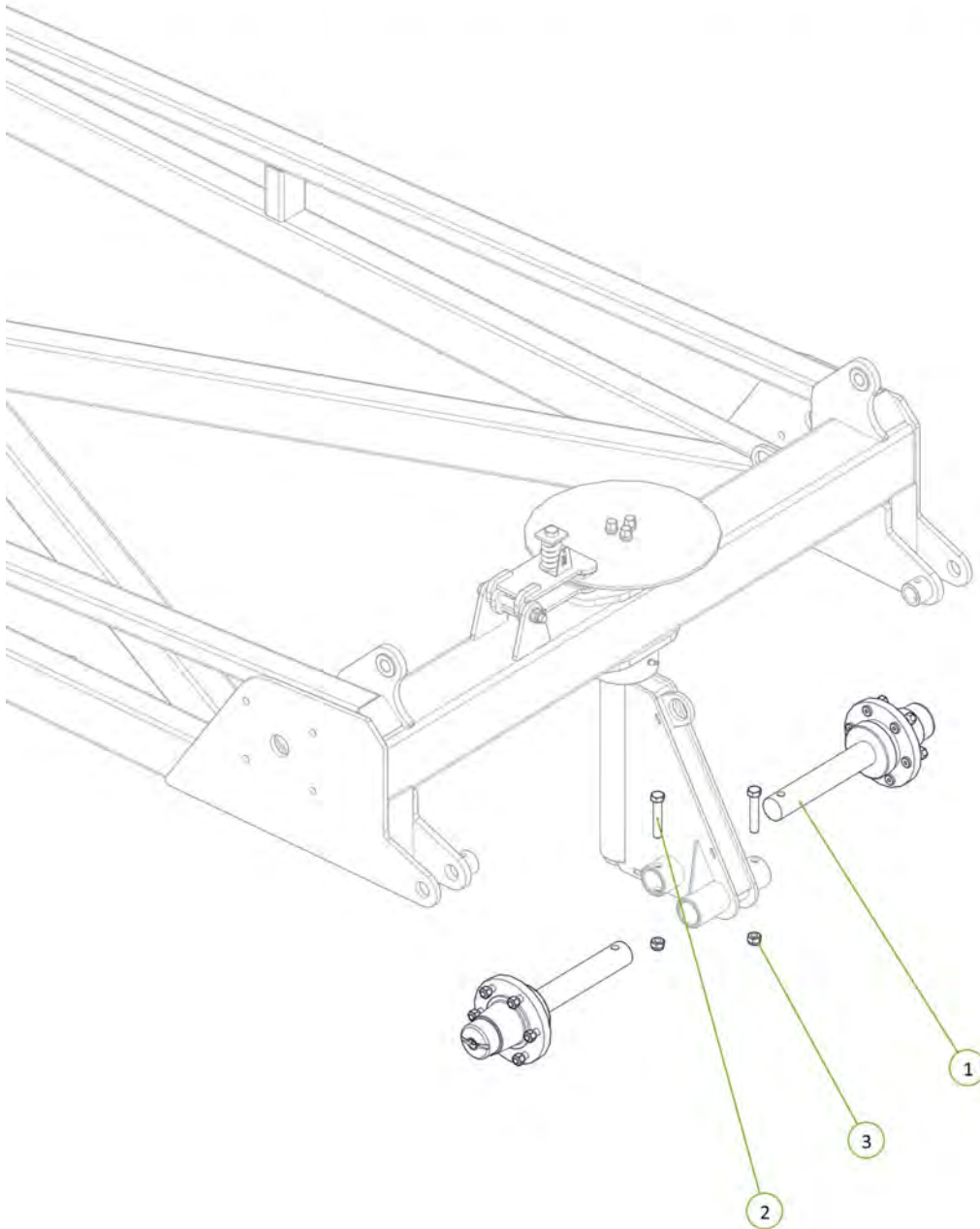

Item No.	Description	Number	Qty
1	11L15 F3 Tyre on 6 on 6" Stud Rim	0751-11L15	2

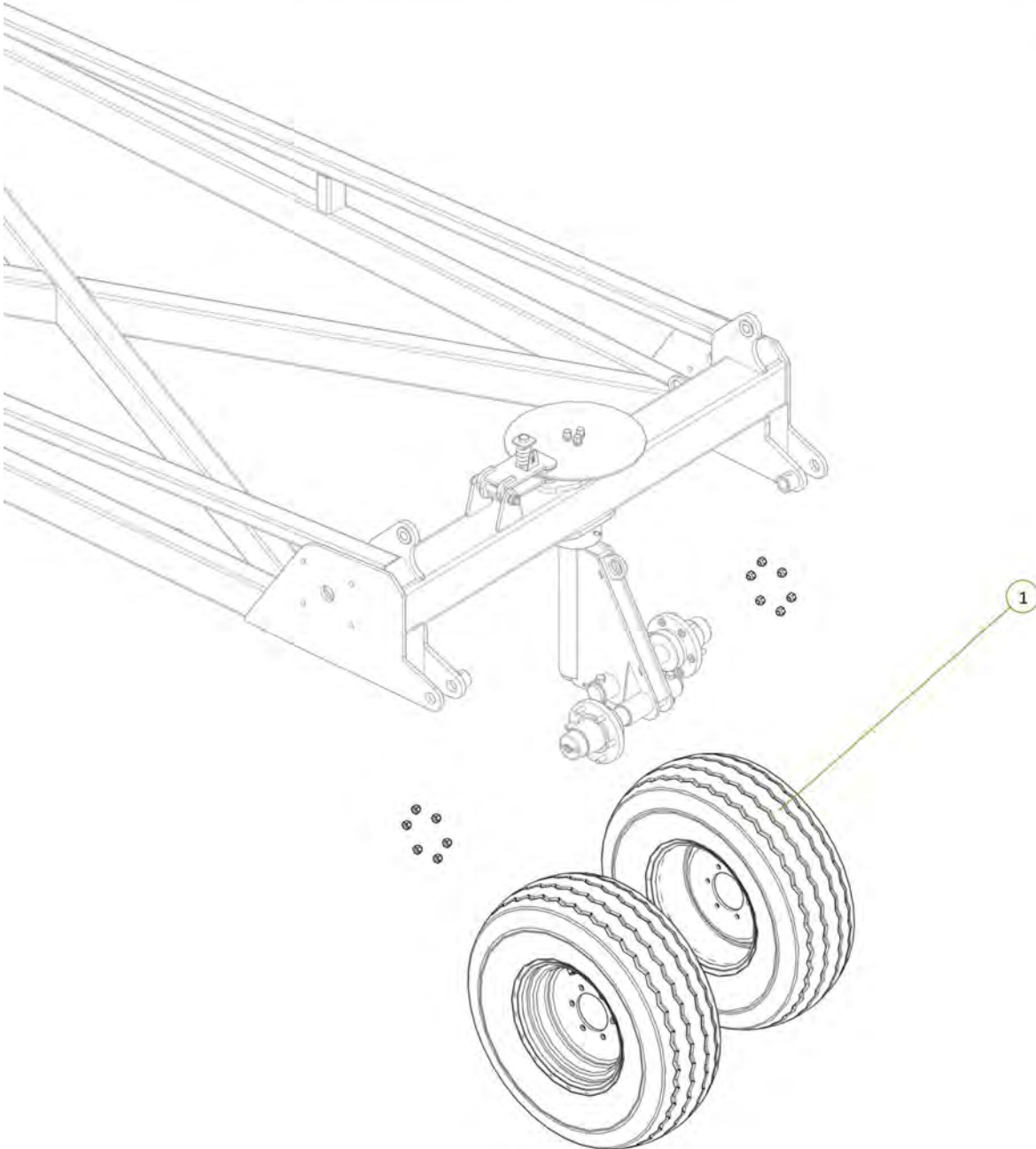
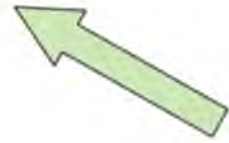

Torque wheel nuts to 90ft-lb / 125nm

Item No.	Description	Number	Qty
1	Extended Tip Rear Tail	0810-10E	1
2	Tail Frame Pivot pin	0801-10-08-175	2
3	M12 x 80 Class 8.8 ZP Bolt	0211-1280	2
4	Nyloc Nut M12	0221-NYL12	2
5	Cotter Pin M13 x 63	0261-PINC1363	2

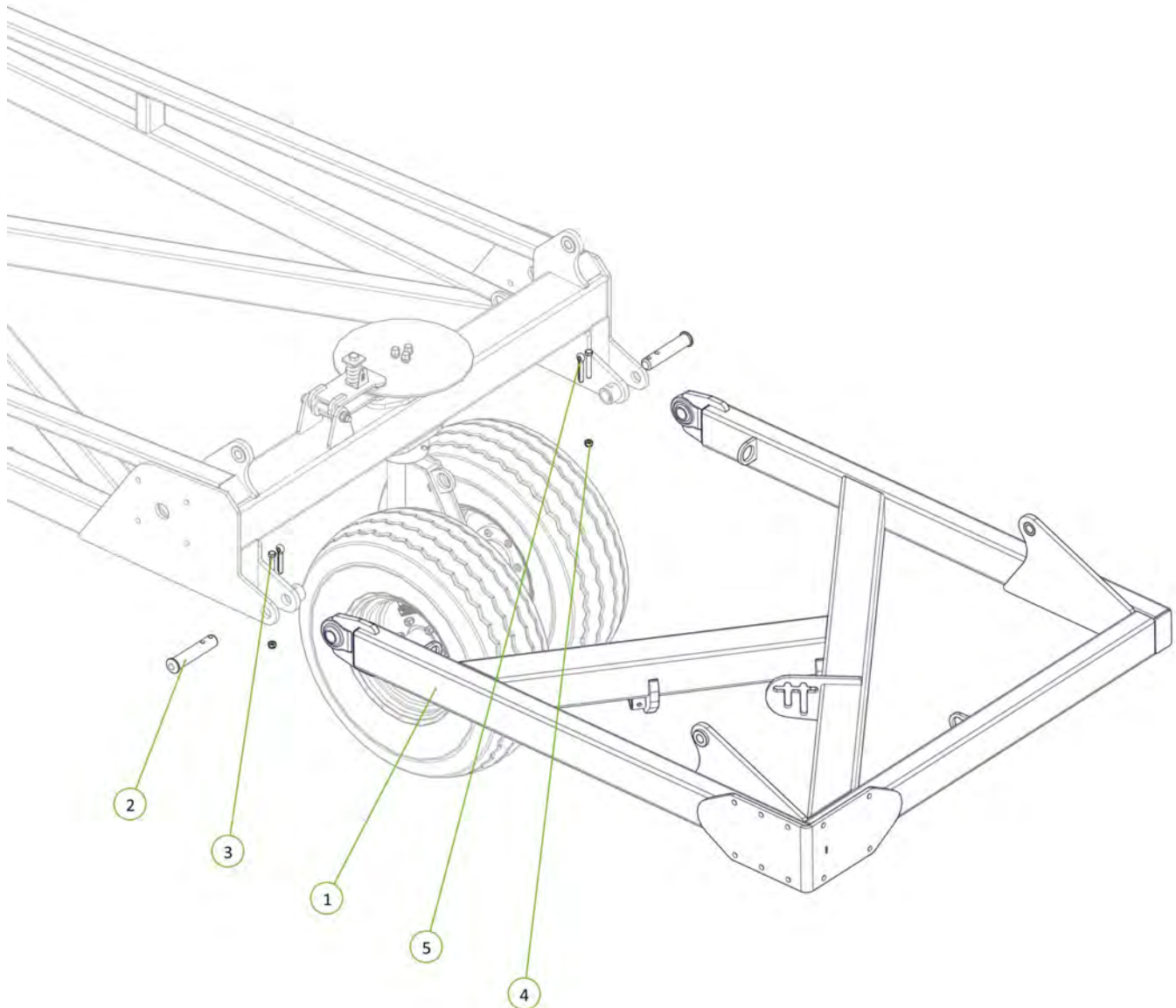

Item No.	Description	Number	Qty
1	3.5" Bore 24" Stroke 1.75" Rod Hydraulic Cylinder	0311-3524SP	2

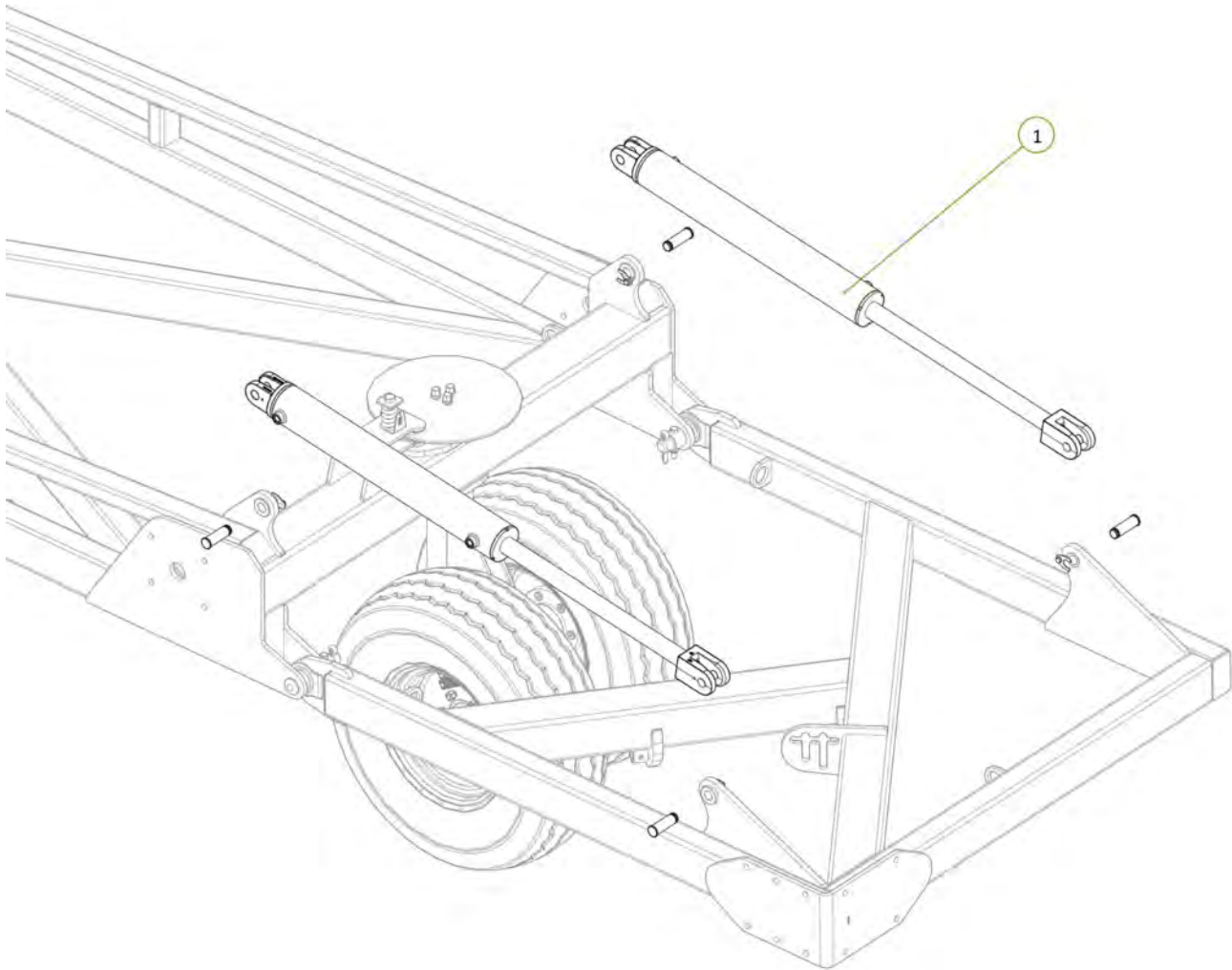
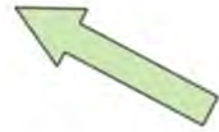

Item No.	Description	Number	Qty
1	3/4" JIC Male 3/4" UN O Ring Male 90° Elbow	0323-S91-1212	4

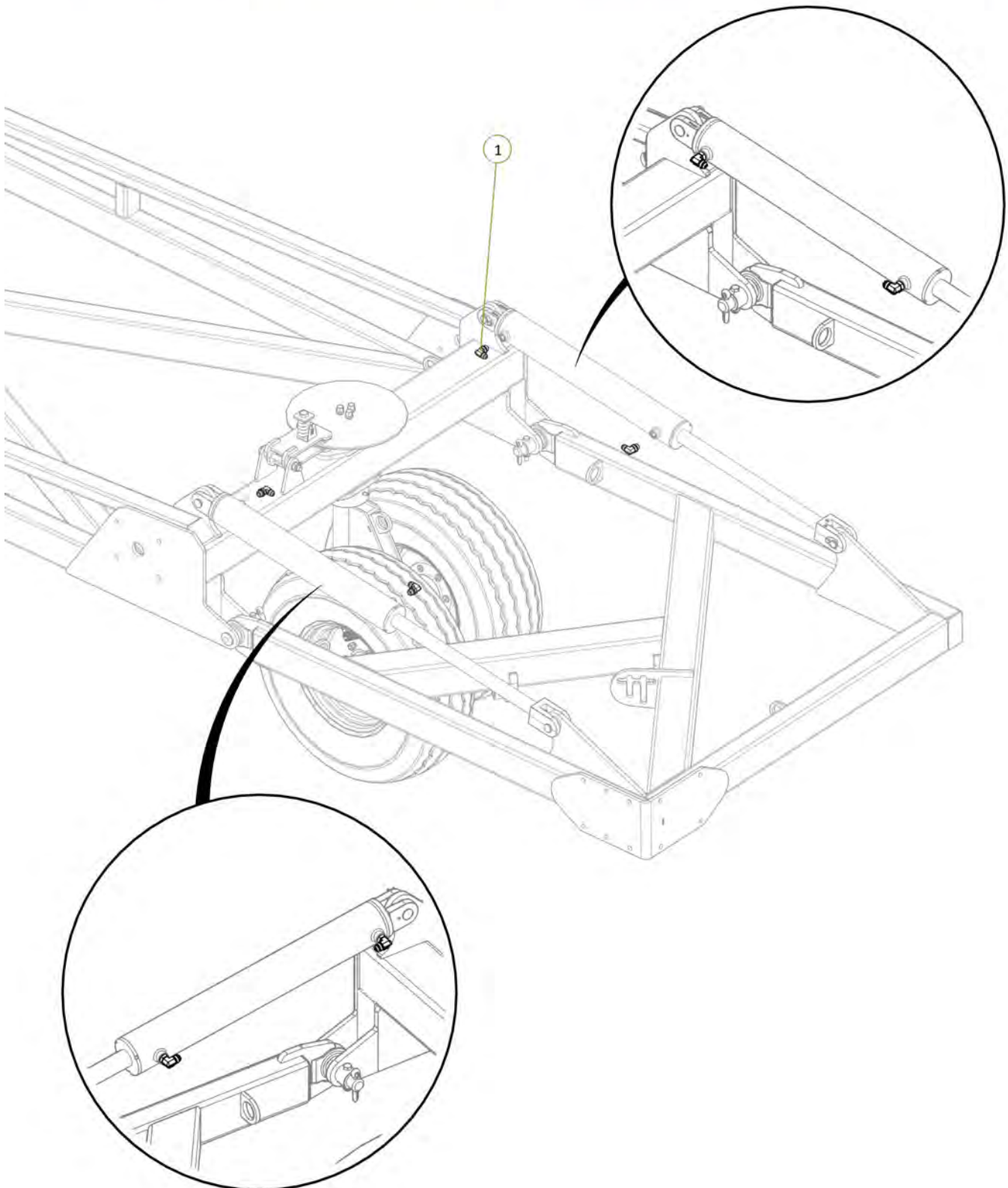
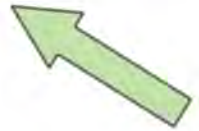

Item No.	Description	Number	Qty
1	TE1 Port to Tail Extend Tee	PH40-04	1
2	TR1 Port to Tail Retract Tee	PH40-05	1
3	3/4" JIC Male Tee 3/4" JIC Male Tee 3/4" JIC Male Tee	0324-S19-121212	2

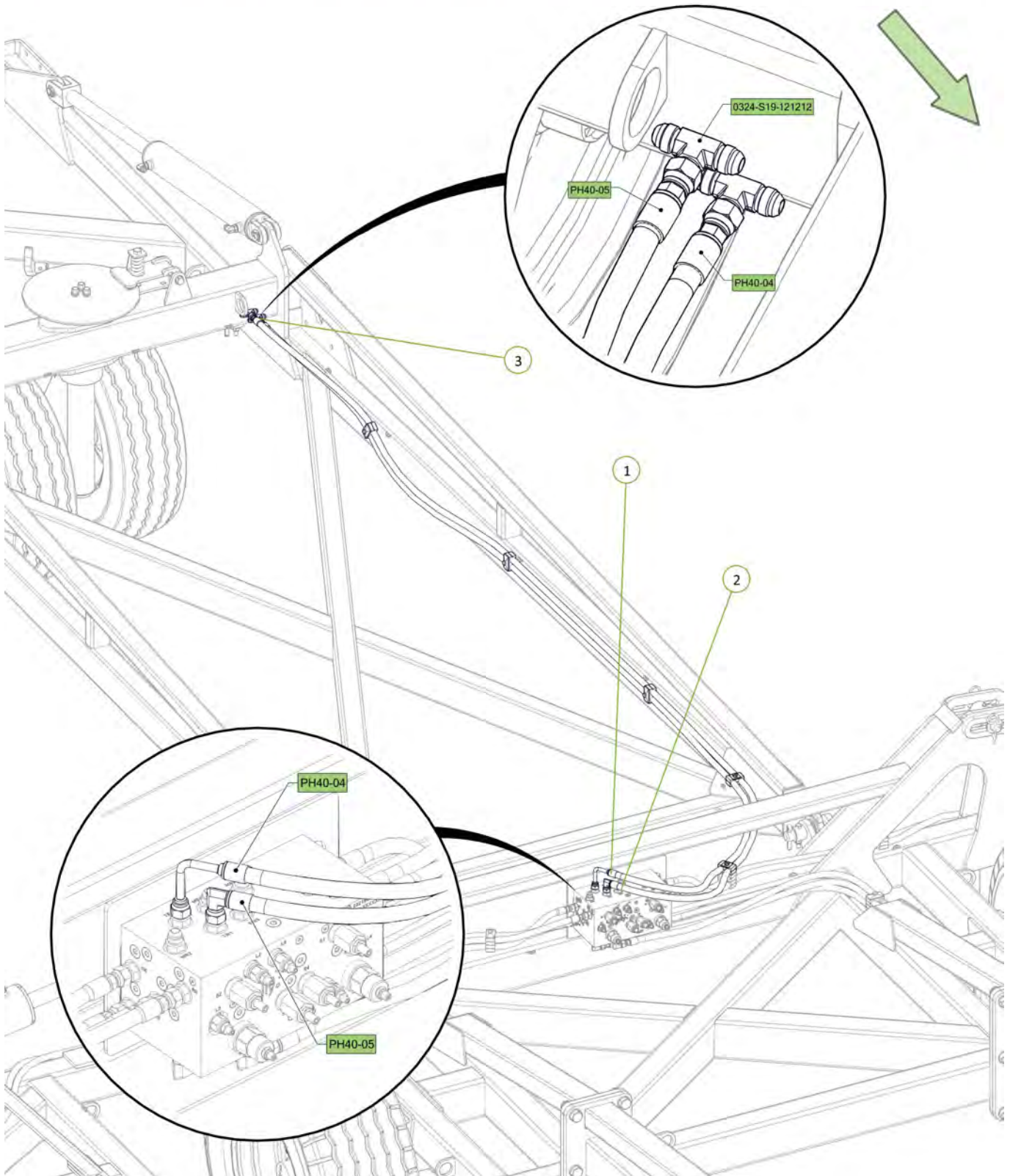

Item No.	Description	Number	Qty
1	Tail Lift Extend Tee to LH Tail Lift Extend Port	PH40-20	1
2	Tail Lift Retract Tee to LH Tail Lift Cylinder Retract Port	PH40-21	1

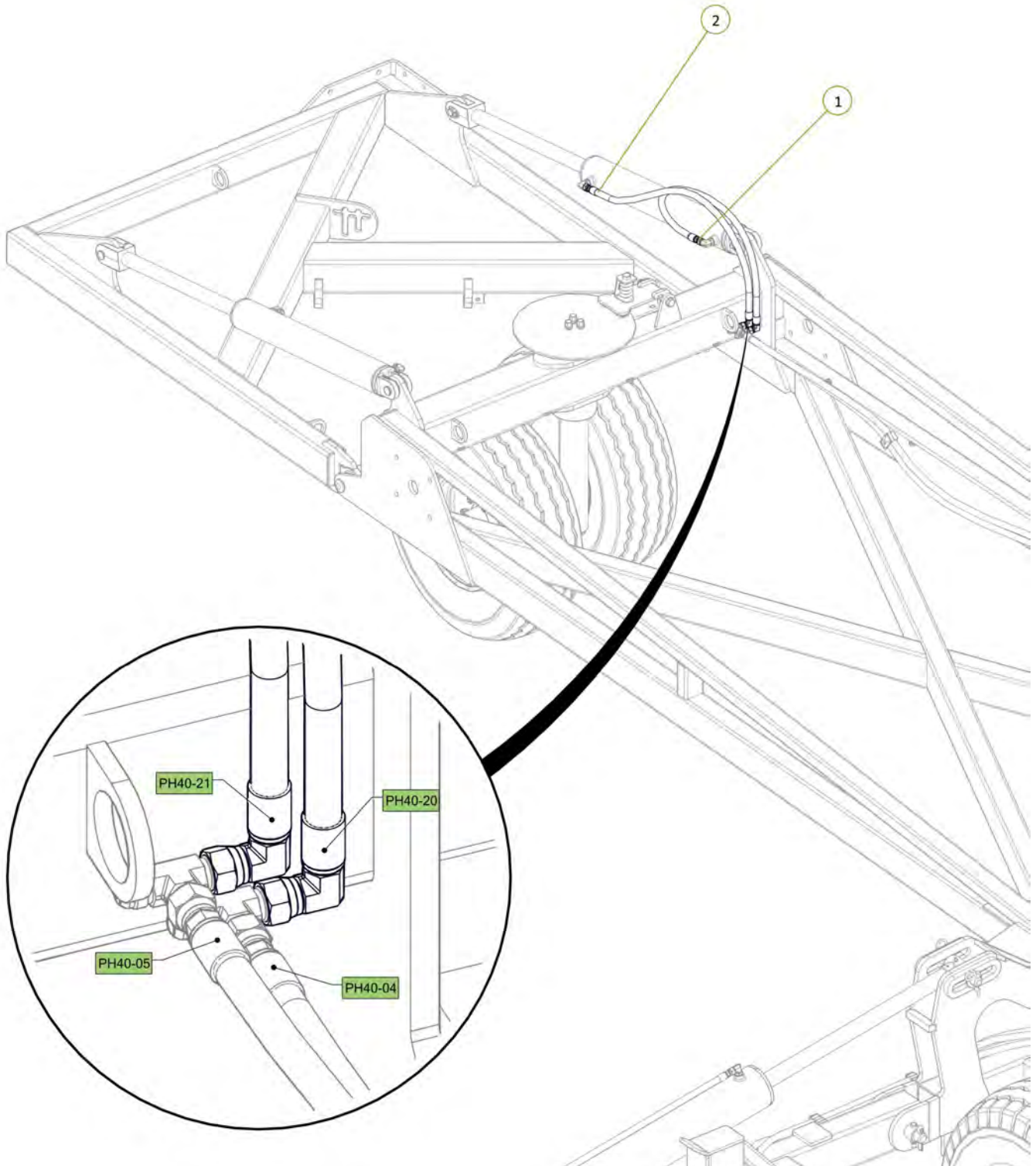
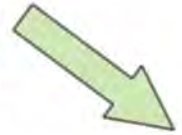

Item No.	Description	Number	Qty
1	Tail Lift Extend Tee to RH Tail Lift Cylinder Extend Port	PH40-22	1
2	Tail Lift Retract Tee to RH Tail Lift Cylinder Retract Port	PH40-23	1

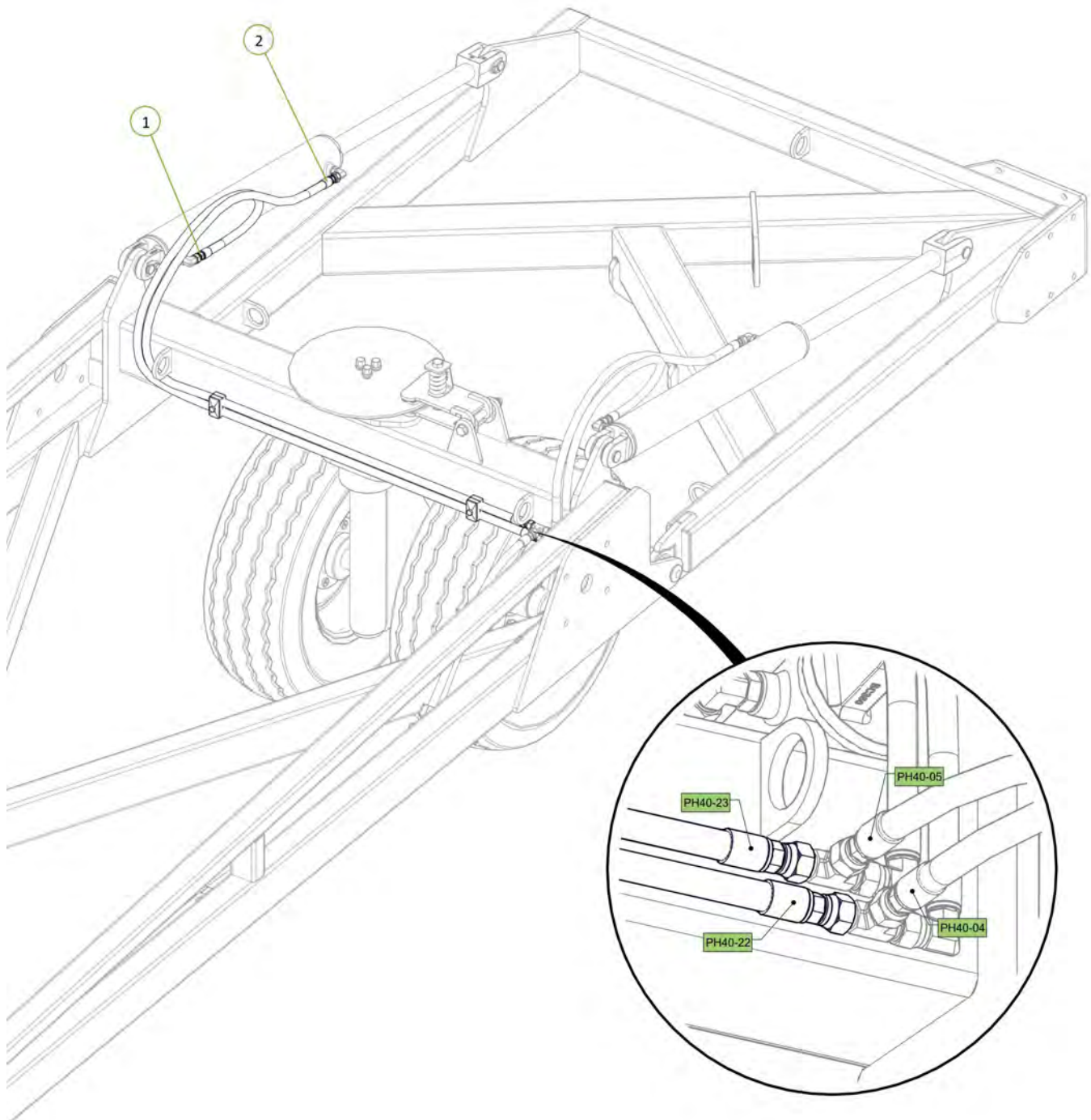

Item No.	Description	Number	Qty
1	Extended Tip Tail Bolt On Tip	0810-10ET	1
2	M16 x 50 grade 8.8 zp Bolt	0211-1650	10
3	Nyloc Nut M16	0221-NYL16	10
4	Washer Flat M16	0231-F16	20

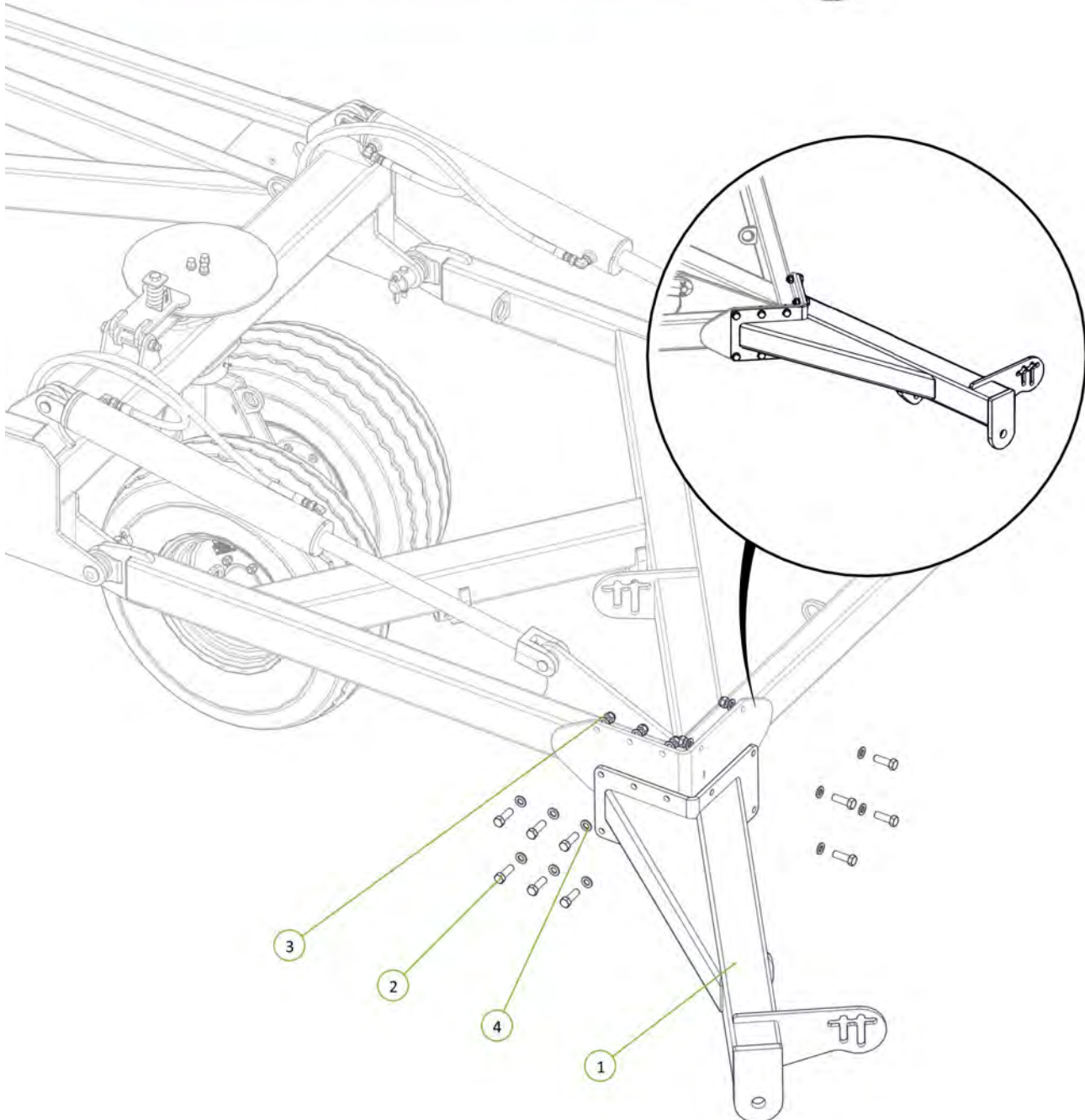

Item No.	Description	Number	Qty
1	40' U-bolt Front Module	0810-28-40-2	1
2	Nyloc Nut M16	0221-NYL16	16
3	U-Bolt M16 x 185 Deep x 104 Wide	0271-16185104	8
4	Washer Flat M16	0231-F16	16

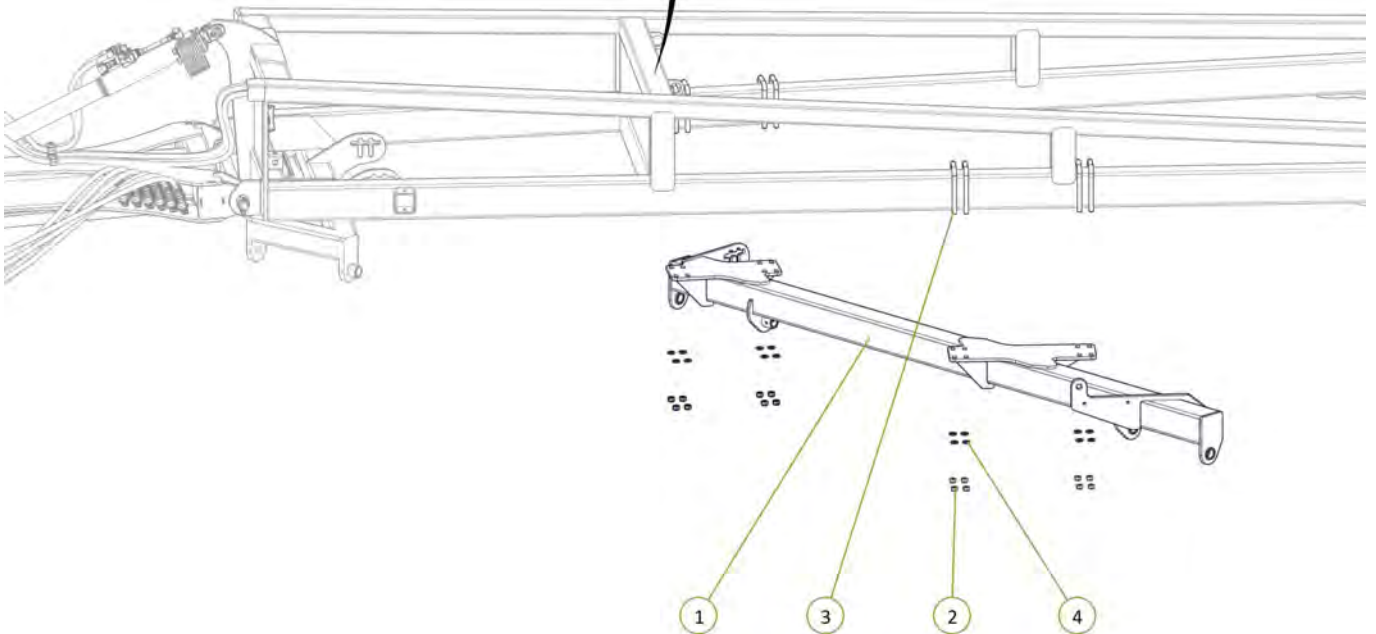
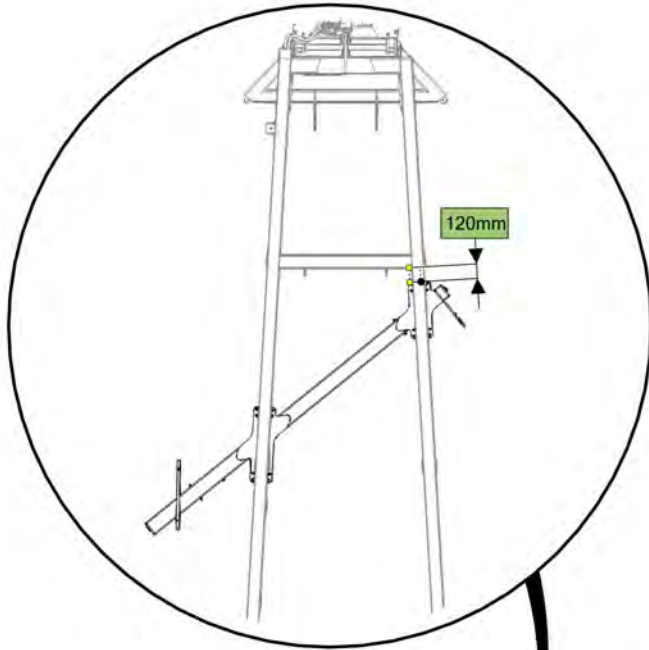
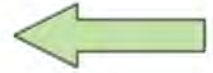

Item No.	Description	Number	Qty
1	40' U-Bolt Rear Module	0810-29-40-2	1
2	U-Bolt M16 x 160 Deep X 77 Wide	0271-1616077	8
3	Nyloc Nut M16	0221-NYL16	16
4	Washer Flat M16	0231-F16	16

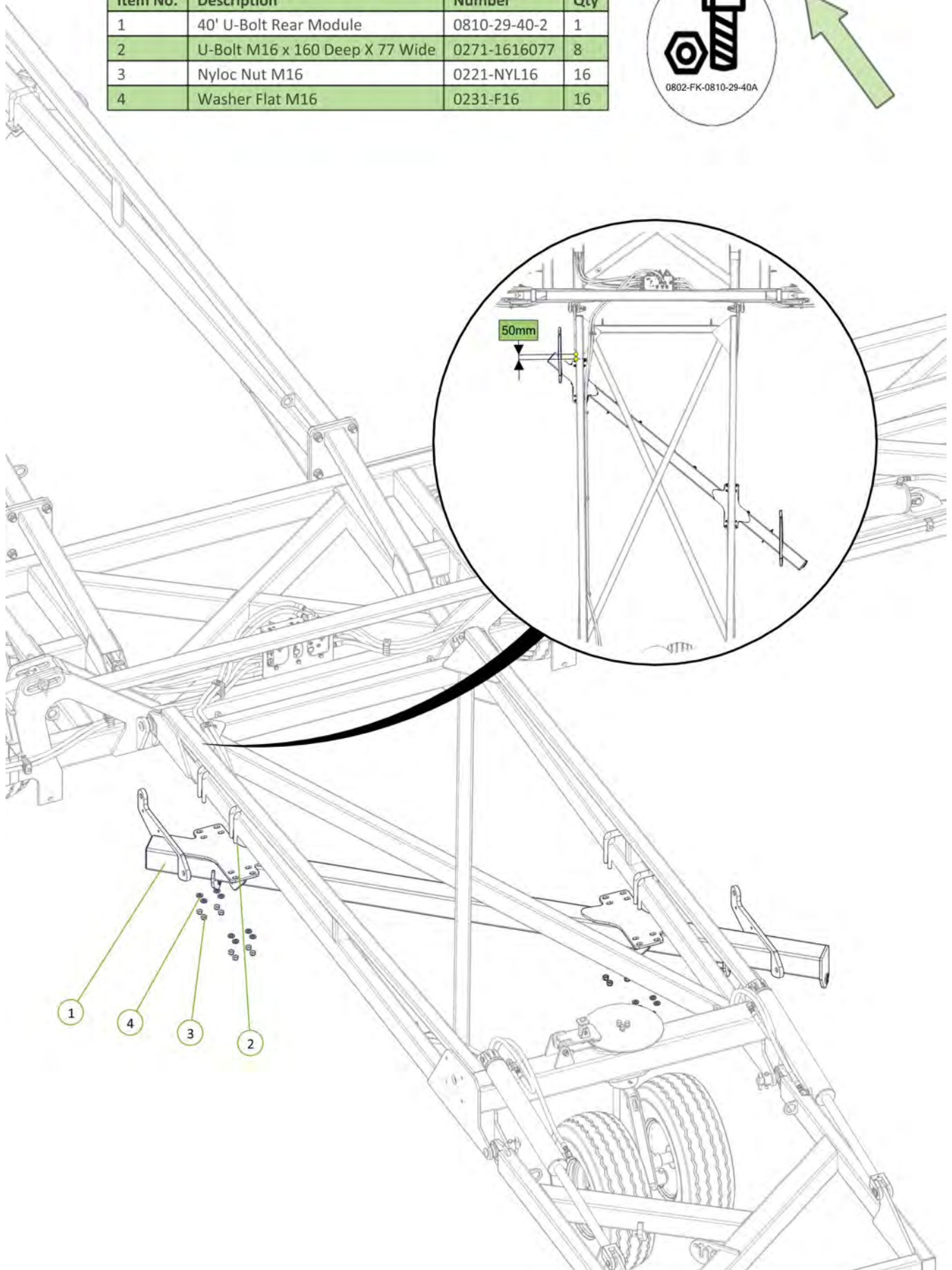

Item No.	Description	Number	Qty
1	Super Single LH Drop Leg No Clevis	0810-24SF	1
2	Super Single RH Drop Leg No Clevis	0810-25SF	1
3	LH Chain Adjusting Lug	0810-26	1
4	RH Chain Adjusting Lug	0810-27	1
5	Forged Clevis 21mm Bolt Hole	0801-FC21	1
6	Stainless Steel Wear Bush	1501-365033-SS	2
7	M24 x 140 grade 8.8 zp Bolt	0211-24140	2
8	Nyloc Nut M24	0221-NYL24	2
9	M36 x 105 grade 8.8 zp Bolt	0211-36105	2
10	Nyloc Nut M36	0221-NYL36	2

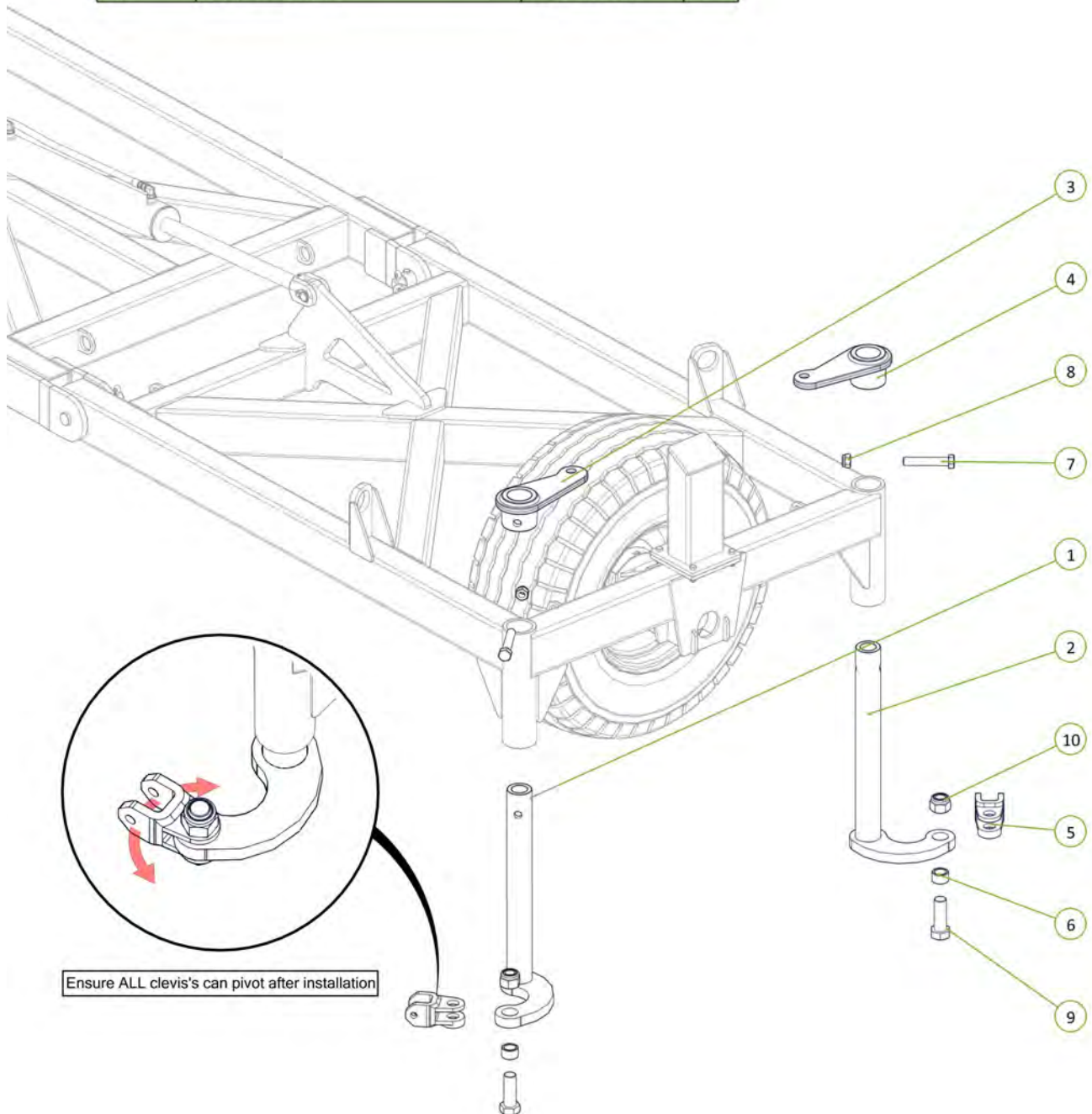

Item No.	Description	Number	Qty
1	Cast 25mm Spacing Half	0801-CS25	24
2	M10 x 30 Class 8.8 ZP Bolt	0211-1030	24
3	Nyloc Nut M10	0221-NYL10	24

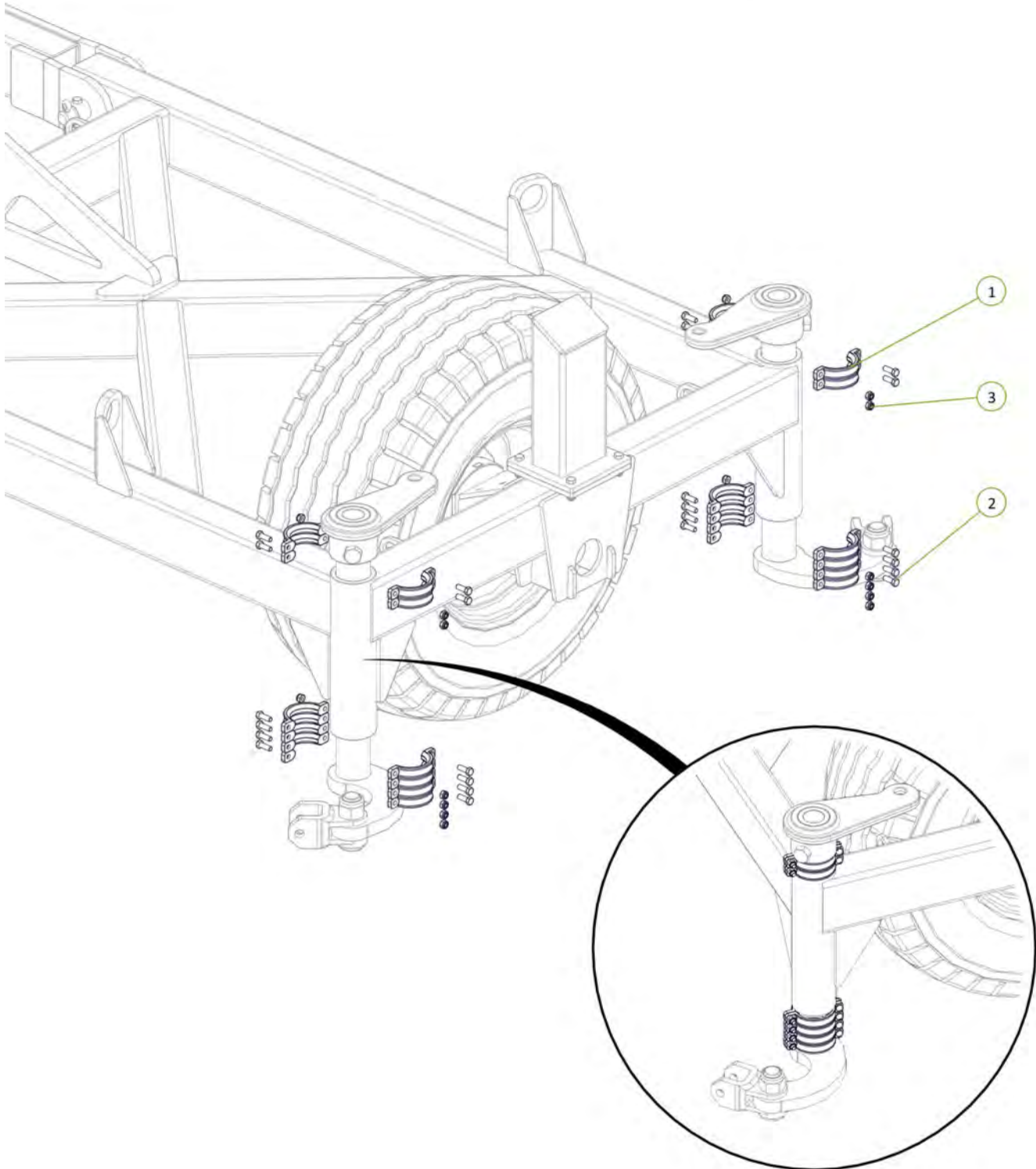

Item No.	Description	Number	Qty
1	Chain Tension Adjustor	0802-PCHTA	2
2	Washer High Tensile 1 1/4"	0232-HT11-4	2
3	Heavy Duty Coil Spring 24mm	0801-K2455350	2
4	Tensioner Cup - Male	0801-KE0805-3	2
5	Female Spring Locator	0801-KE0805-4	2

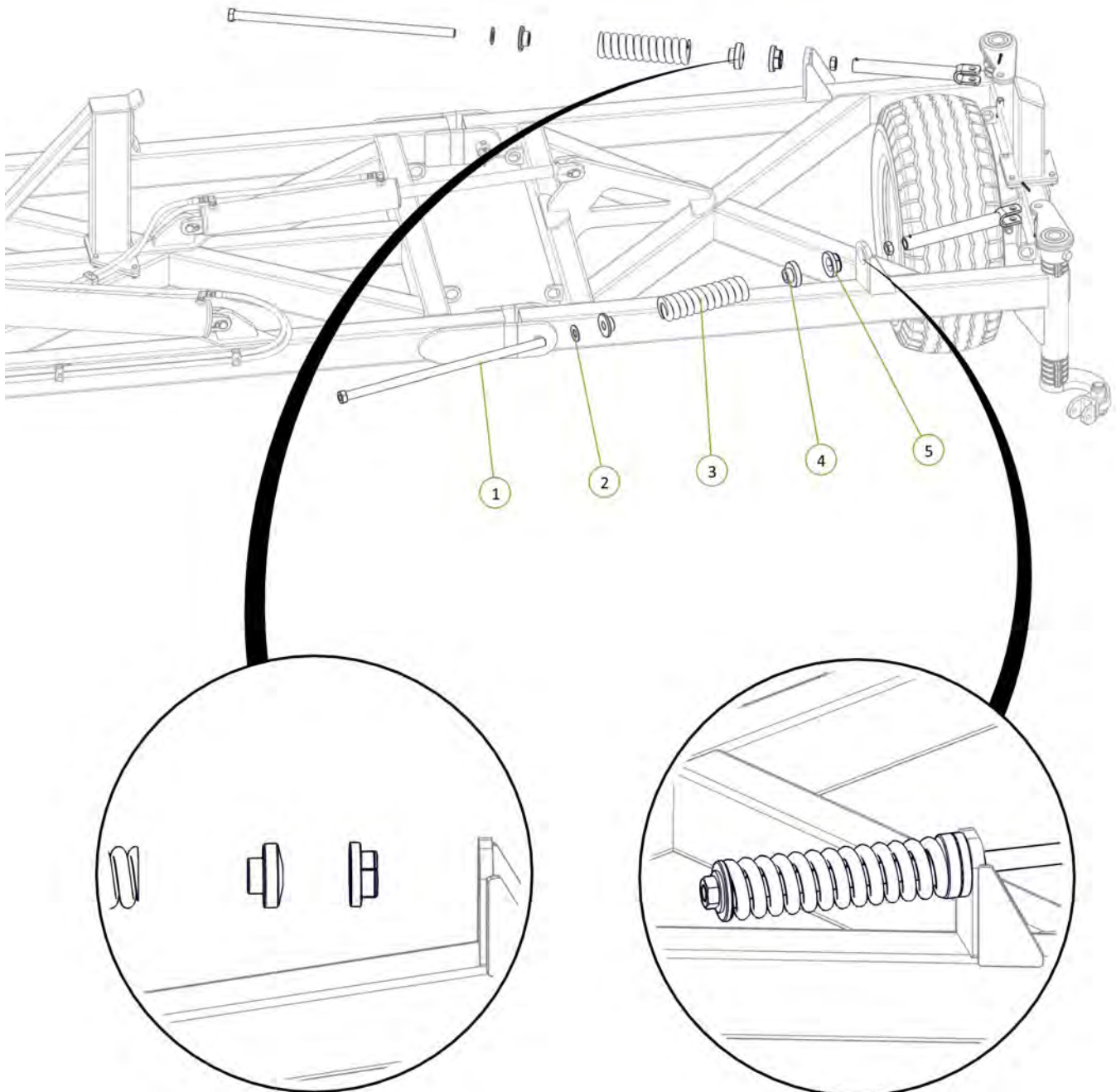

Item No.	Description	Number	Qty
1	Super Single RH Drop Leg No Clevis	0810-25SF	1
2	Super Single LH Drop Leg No Clevis	0810-24SF	1
3	LH Chain Adjusting Lug	0810-26	1
4	RH Chain Adjusting Lug	0810-27	1
5	Stainless Steel Wear Bush	1501-365033-SS	2
6	Forged Clevis 21mm Bolt Hole	0801-FC21	2
7	M36 x 105 grade 8.8 zp Bolt	0211-36105	2
8	Nyloc Nut M36	0221-NYL36	2
9	M24 x 140 grade 8.8 zp Bolt	0211-24140	2
10	Nyloc Nut M24	0221-NYL24	2

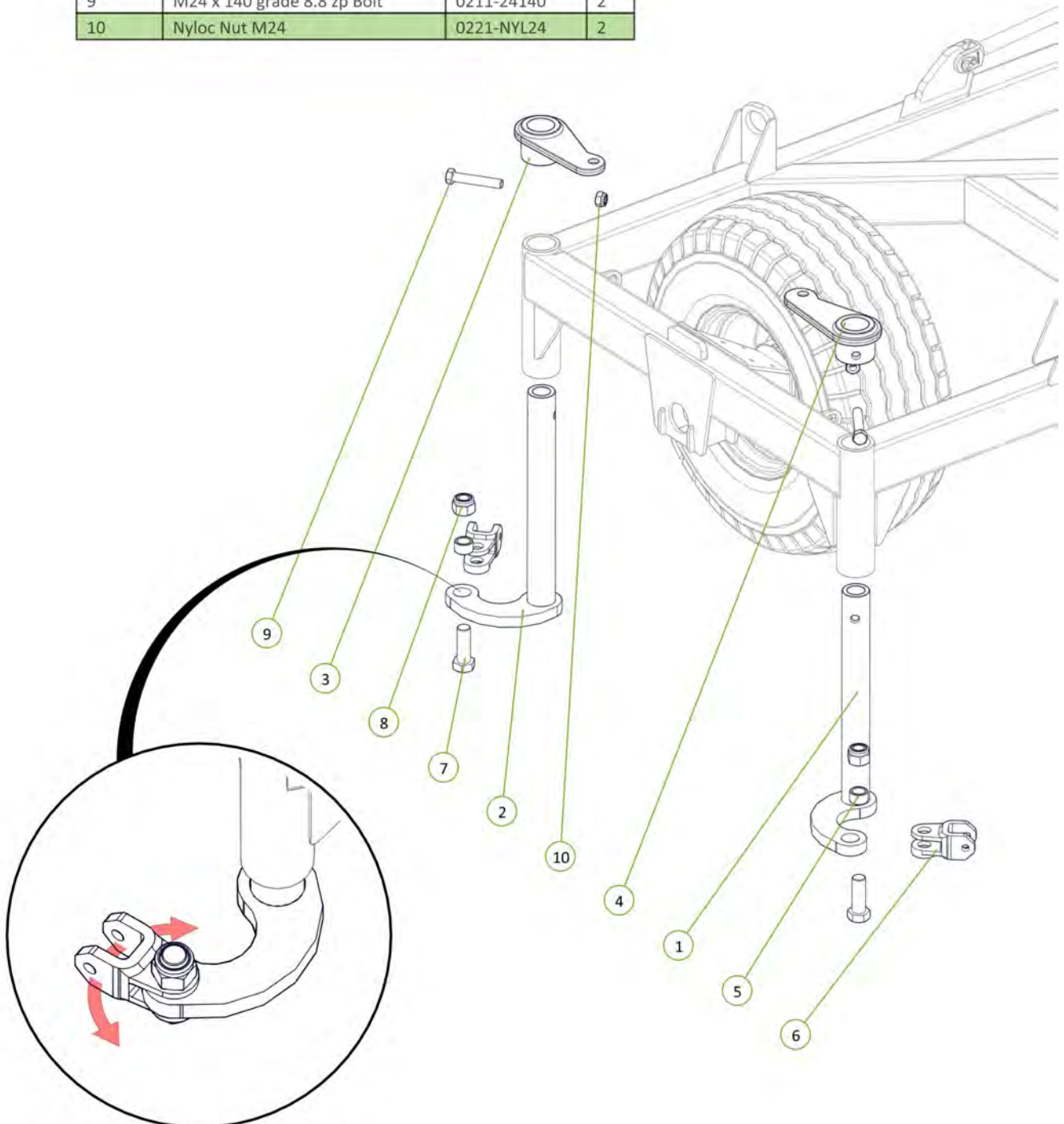

Ensure ALL clevis's can pivot after installation

Item No.	Description	Number	Qty
1	Cast 25mm Spacing Half	0801-CS25	24
2	M10 x 30 Class 8.8 ZP Bolt	0211-10	24
3	Nyloc Nut M10	0221-NYL10	24

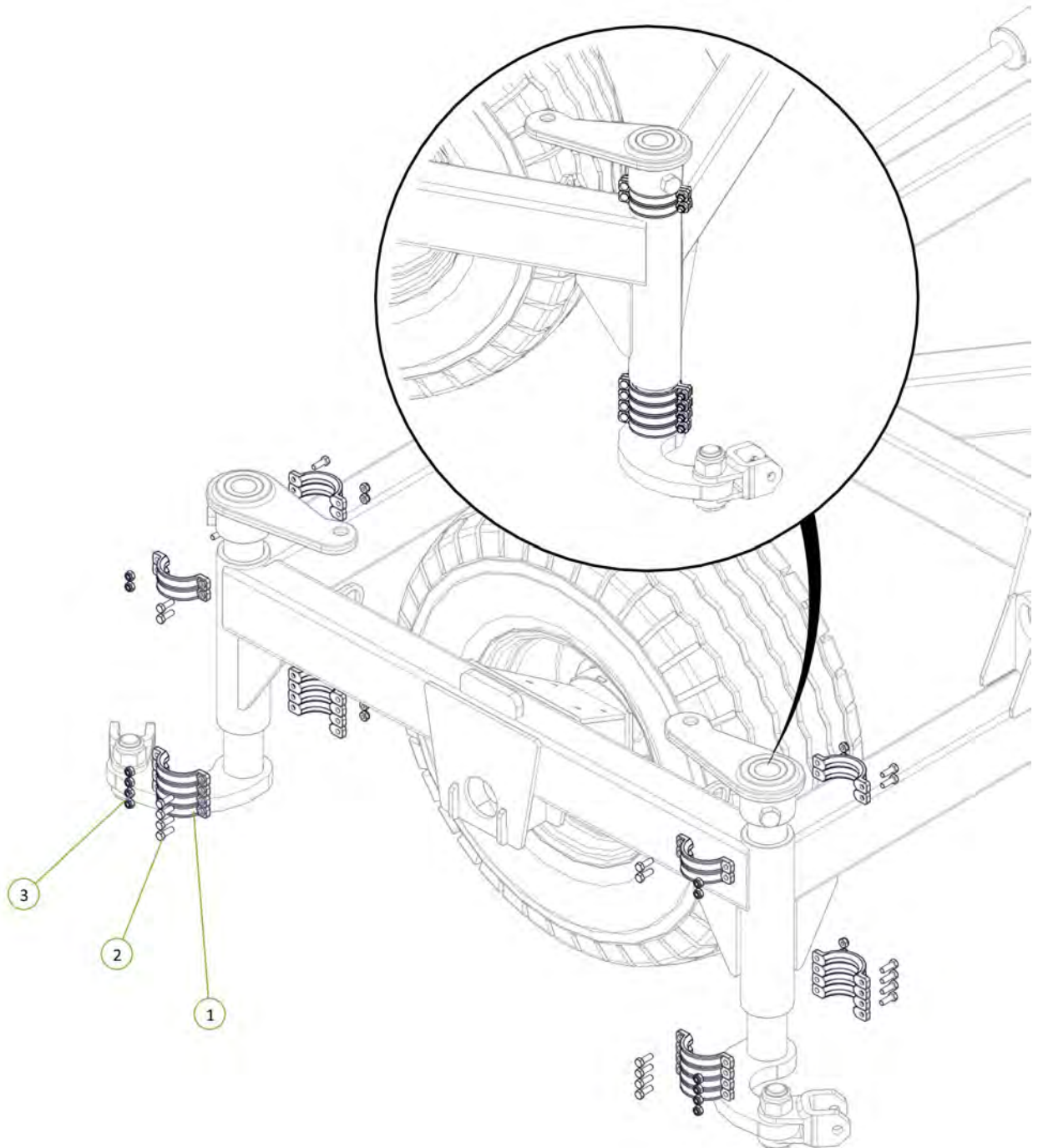

Item No.	Description	Number	Qty
1	Chain Tension Adjustor	0802-PCHTA	2
2	Washer High Tensile 1 1/4"	0232-HT11-4	2
3	Heavy Duty Coil Spring 24mm	0801-K2455350	2
4	Tensioner Cup - Male	0801-KE0805-3	2
5	Female Spring Locator	0801-KE0805-4	2

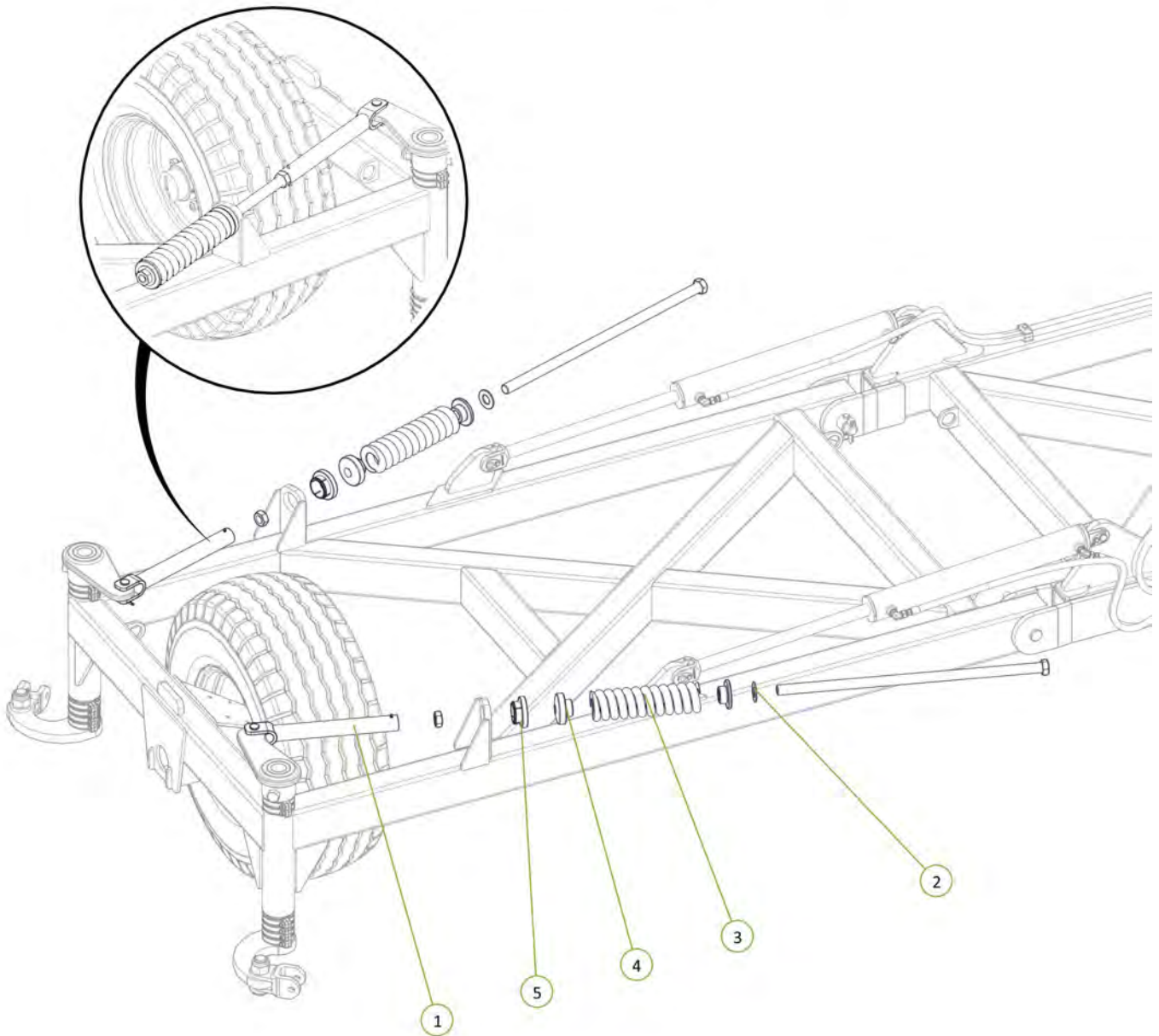

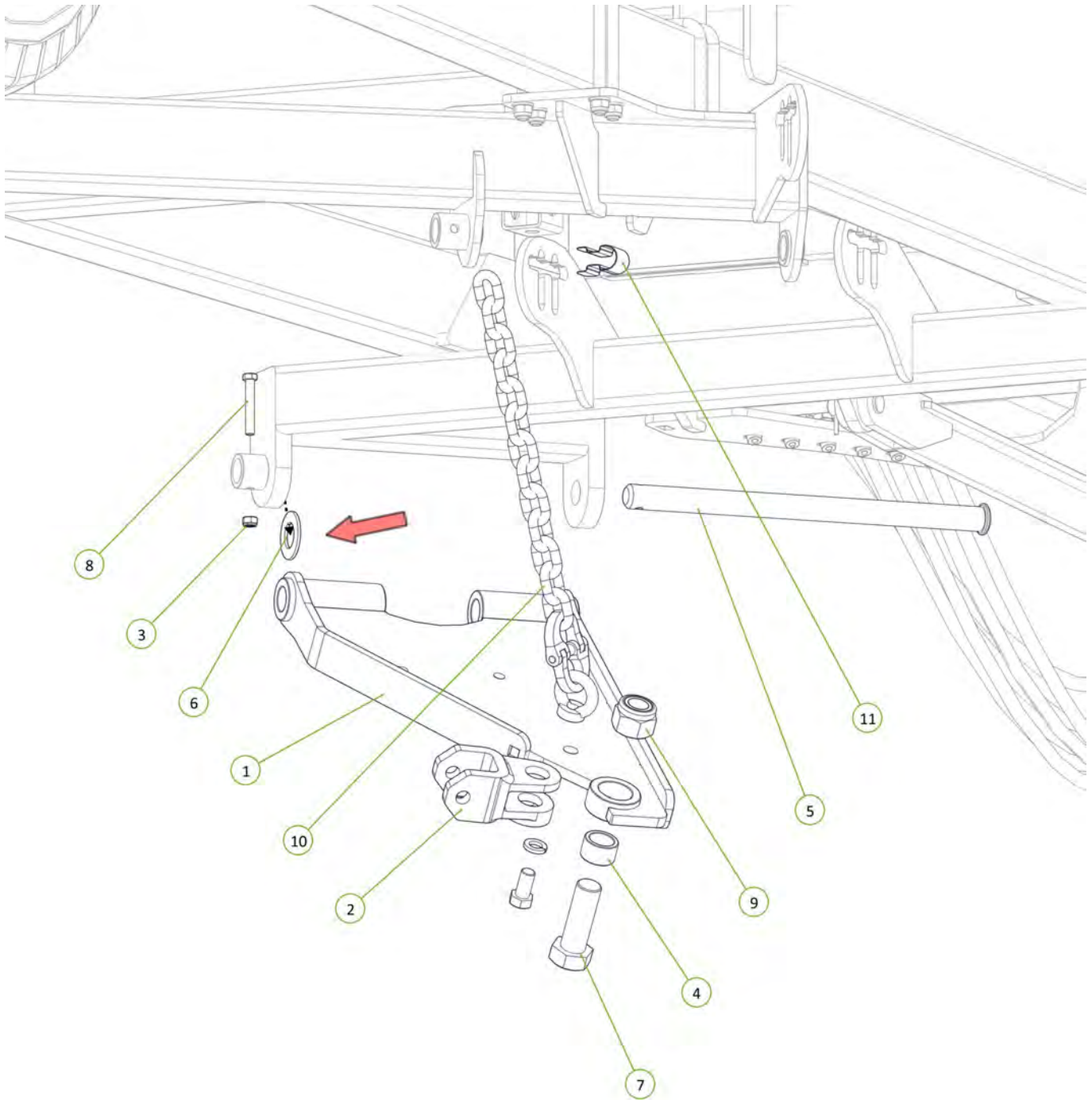

Item No.	Description	Number	Qty
1	Standard Chain Mount Plate	0810-20	1
2	Forged Clevis 21mm Bolt Hole	0801-FC21	1
3	Nyloc Nut M12	0221-NYL12	1
4	Stainless Steel Wear Bush	1501-365033-SS	1
5	Chain Mount Pivot Pin	0801-10-51	1
6	Washer High Tensile 1 3/8"	0232-HT13-8	1
7	M36 x 105 grade 8.8 zp Bolt	0211-36105	1
8	M12 x 80 Class 8.8 ZP Bolt	0211-1280	1
9	Nyloc Nut M36	0221-NYL36	1
10	Height Adjusting Chain Assembly 13 Link	0801-20MCA	1
11	Height Adjustor Retaining Clip	0801-KE014	1



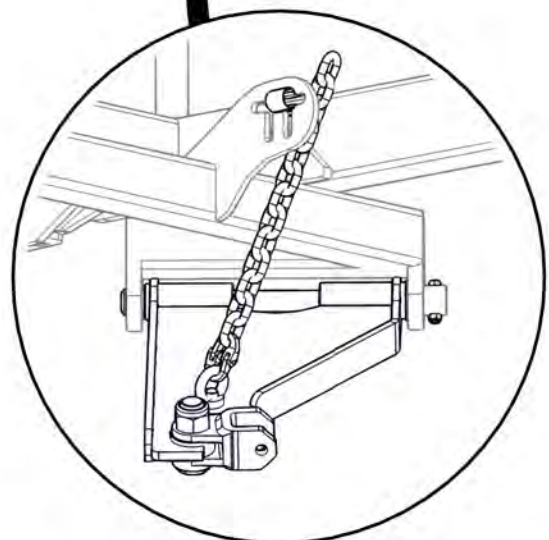
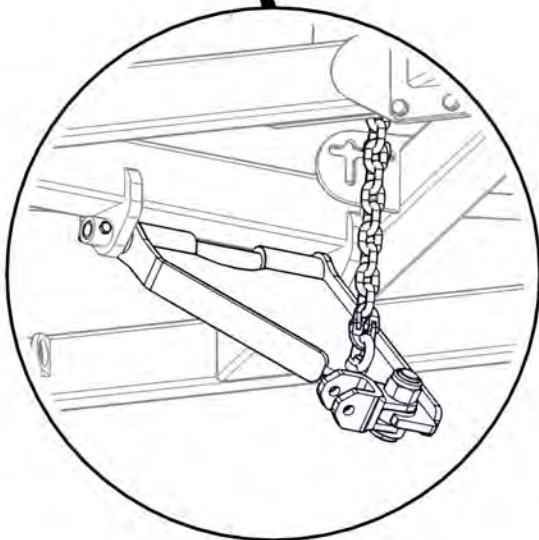
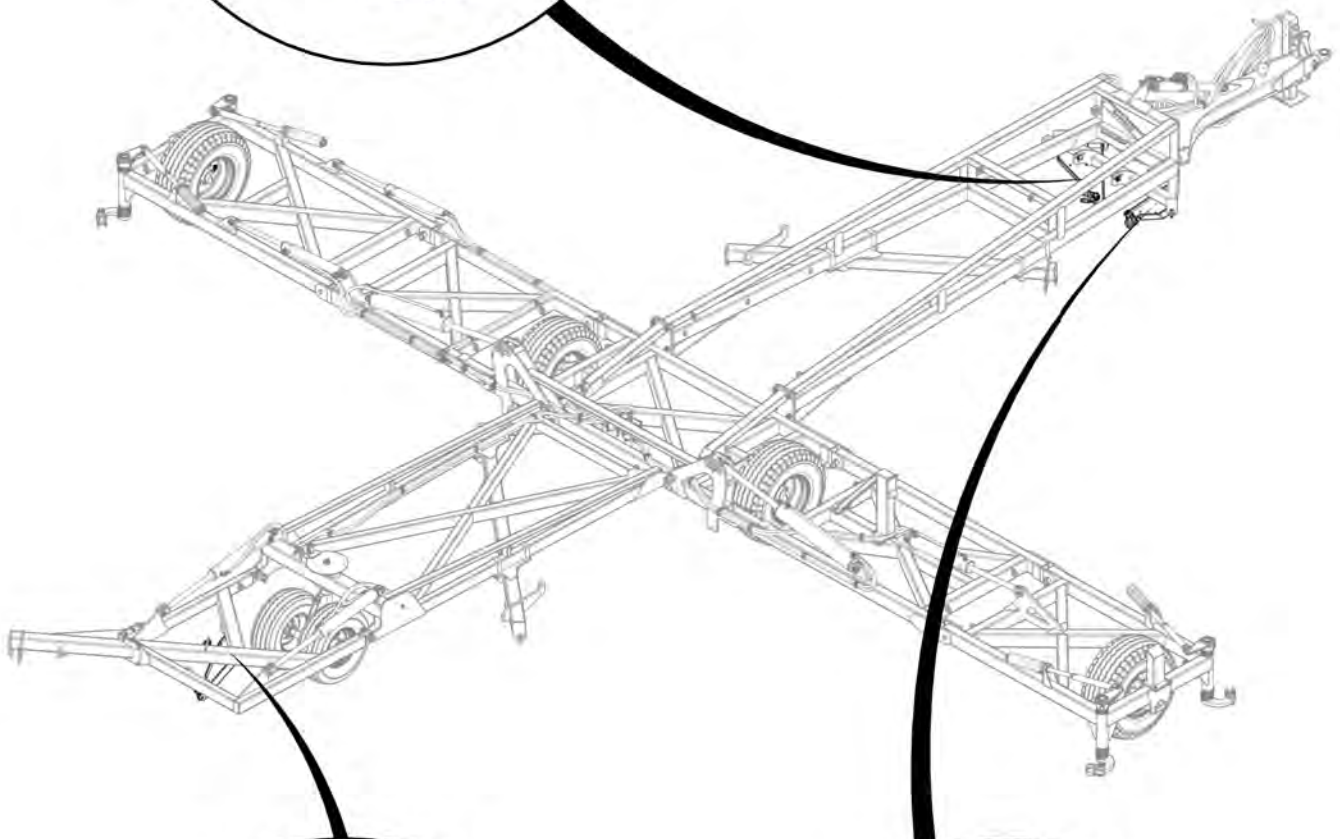
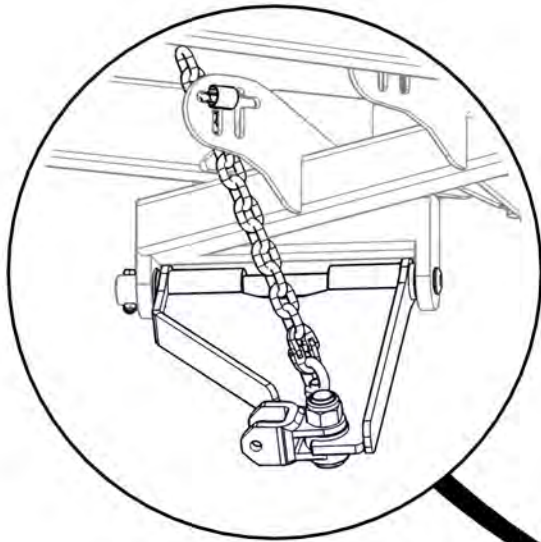

Item No.	Description	Number	Qty
1	Extended Chain Mount Plate	0810-30	1
2	Forged Clevis 21mm Bolt Hole	0801-FC21	1
3	Height Adjusting Chain Assembly 13 Link	0801-20MCA	1
4	Stainless Steel Wear Bush	1501-365033-SS	1
5	Chain Mount Pivot Pin	0801-10-51	1
6	M36 x 105 grade 8.8 zp Bolt	0211-36105	1
7	Nyloc Nut M36	0221-NYL36	1
8	Washer High Tensile 1 3/8"	0232-HT13-8	1
9	M12 x 80 Class 8.8 ZP Bolt	0211-1280	1
10	Nyloc Nut M12	0221-NYL12	1
11	Height Adjustor Retaining Clip	0801-KE014	1

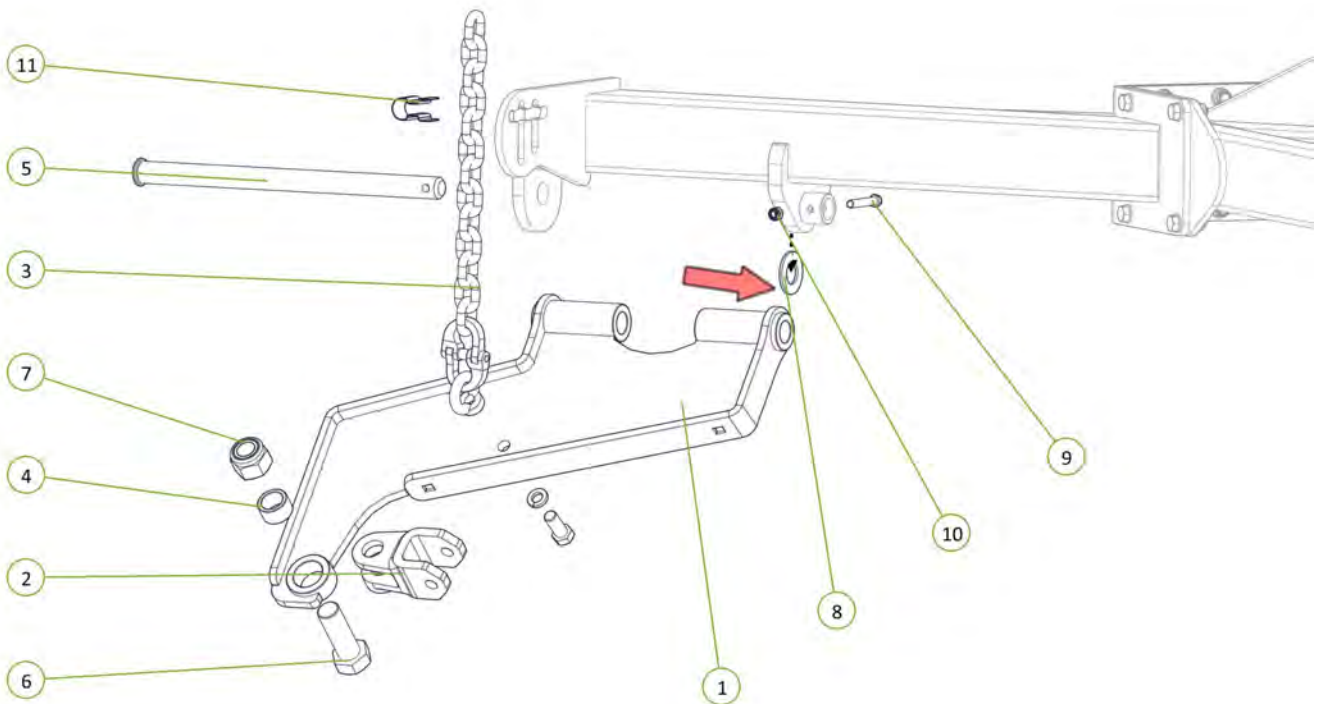

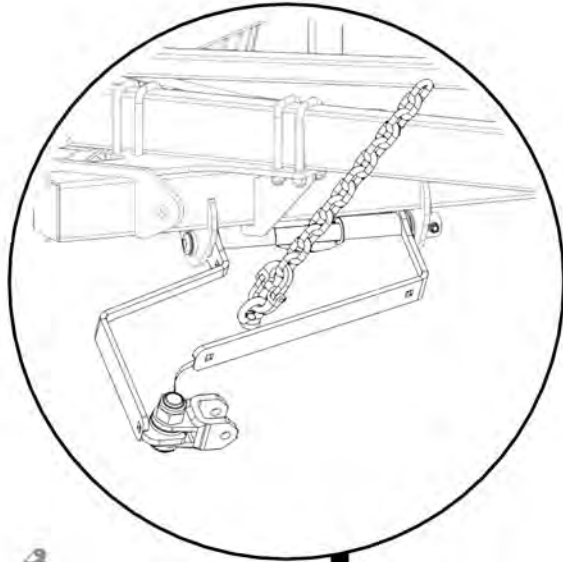

0802-FK-0810-10EA
0802-FK-0810-29-40A
0802-FK-0810-28-40A

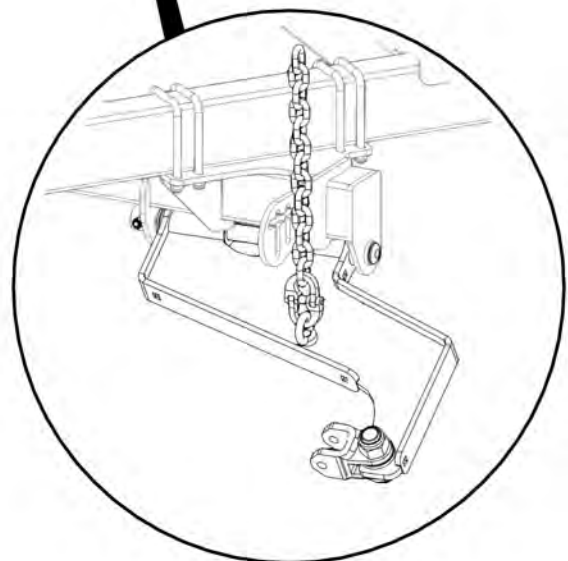
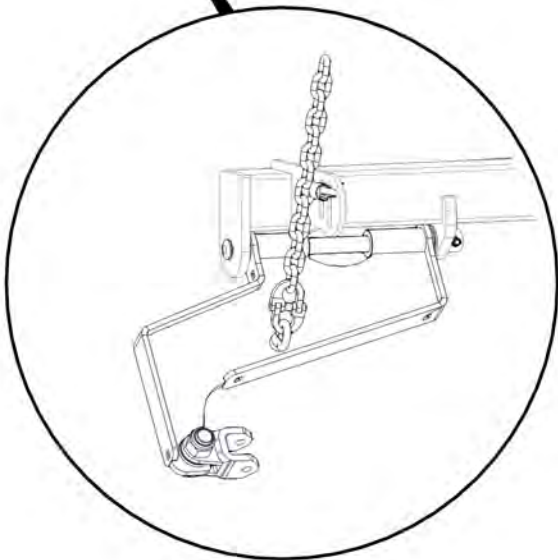
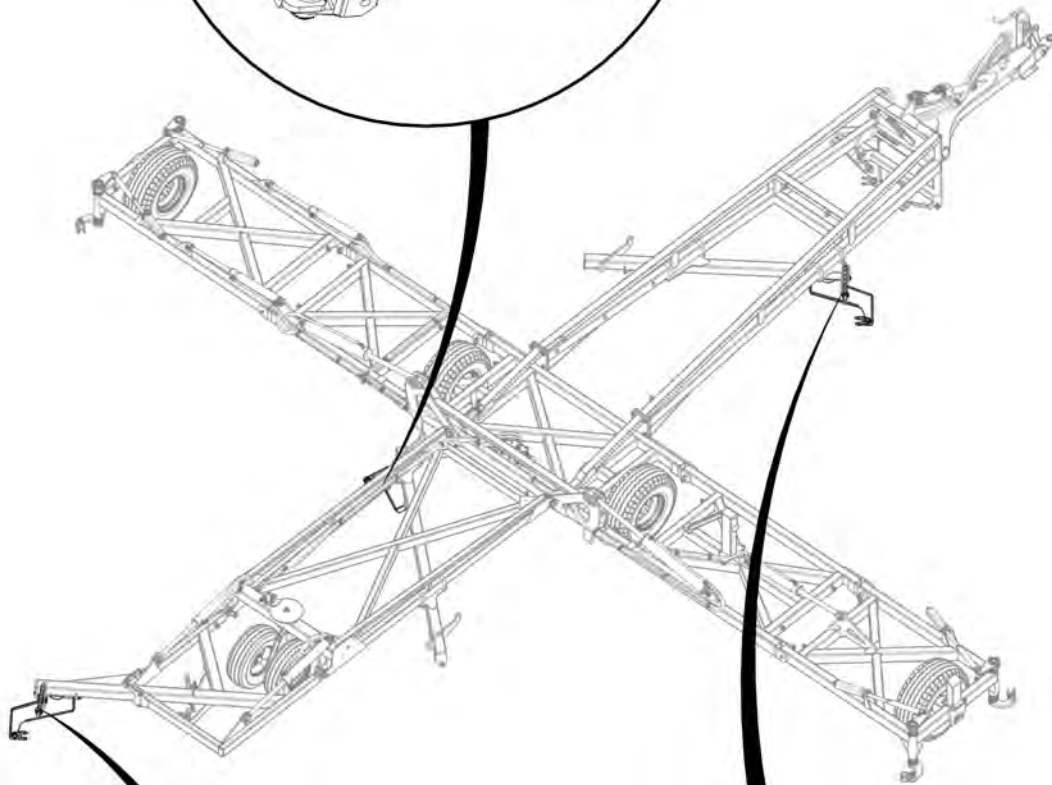

Item No.	Description	Number	Qty
1	Tension Box	0810-57	1
2	Module Tension Rod Assembly	0810-105A	1
3	Rigid Spring Locator	0801-10-S2L	1
4	Washer High Tensile 1 1/4"	0232-HT11-4	1
5	Height Adjusting Chain Assembly 13 Link	0801-20MCA	1
6	Heavy Duty Coil Spring 24mm	0801-K2455350	1

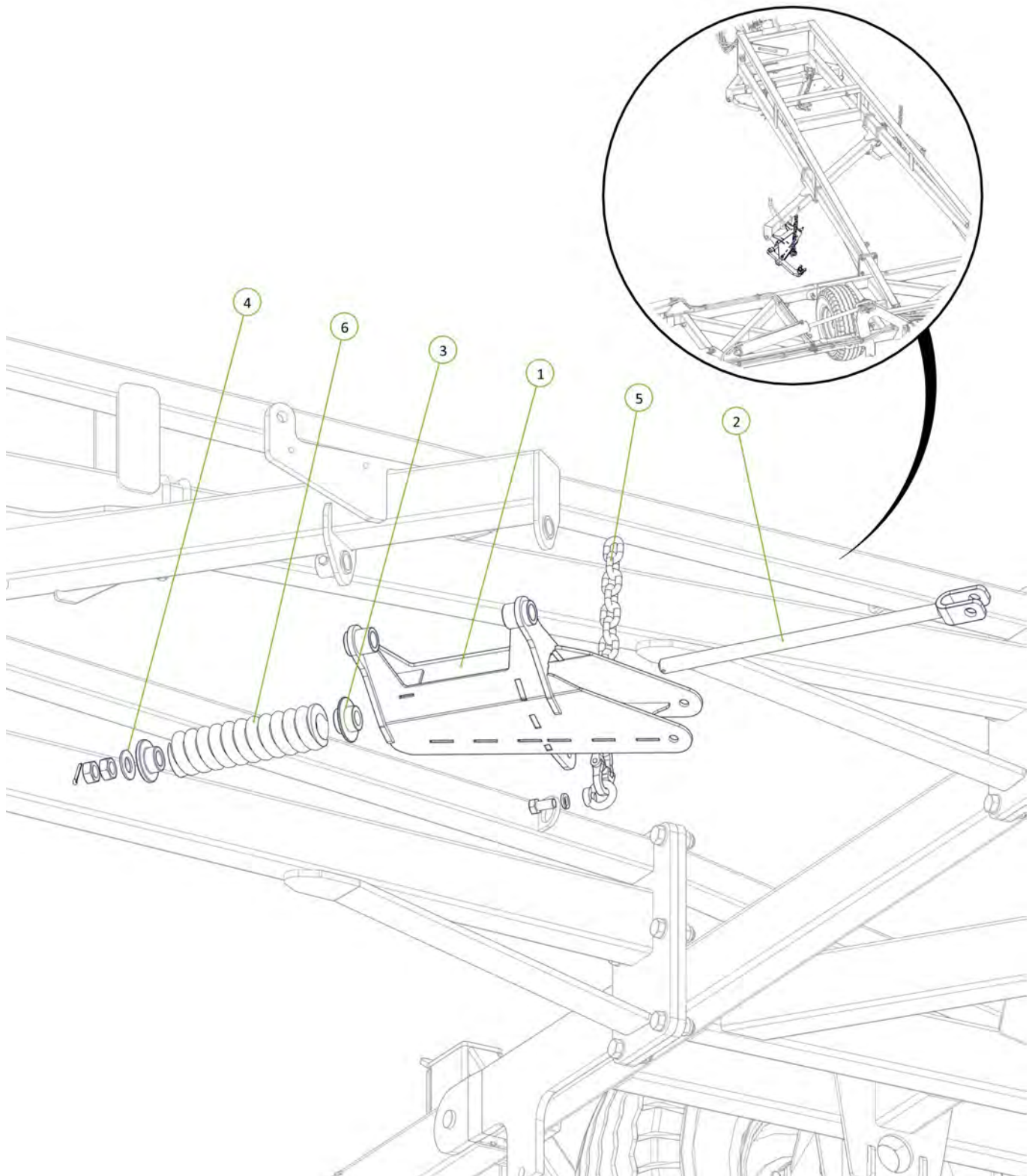

Item No.	Description	Number	Qty
1	Module Tension Arm No Clevis	0810-104F	1
2	Forged Clevis 21mm Bolt Hole	0801-FC21	1
3	35 ID x 50mm DU Bush	0113-MB3550DU	2
4	Module Pivot Arm Bush	0801-10-110	1
5	M36 Grade 8.8 ZP Bolt	0211-36105	1
6	Wear Bush	1501-365033-SS	1
7	Nyloc Nut M36	0221-NYL36	1
8	M20 x 160 Class 8.8 ZP Bolt	0211-20160	1
9	Washer Flat M24	0231-F24	1
10	Washer Flat M20	0231-F20	2
11	Nyloc Nut M20	0221-NYL20	1

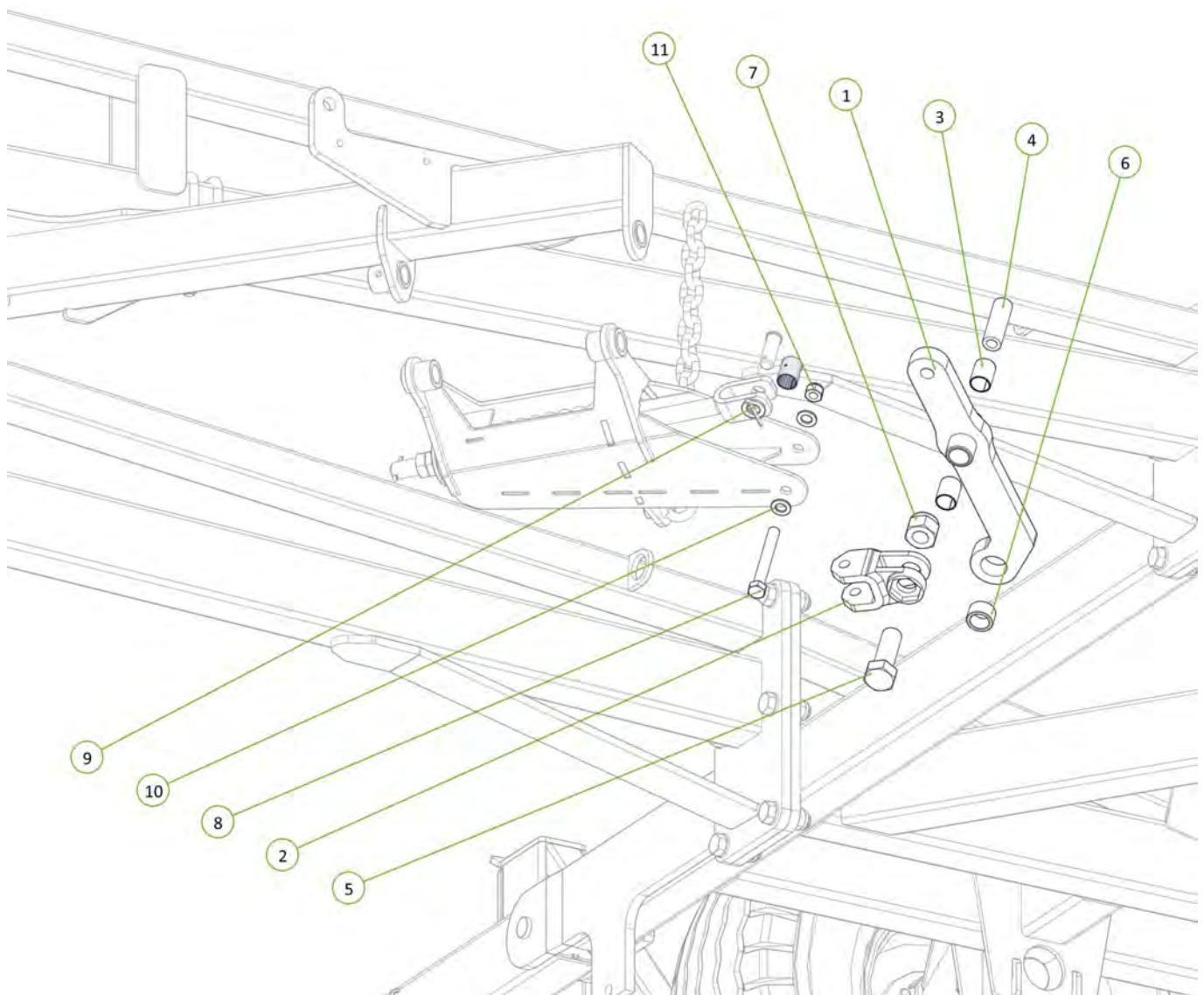

Item No.	Description	Number	Qty
1	Chain Mount Pivot Pin	0801-10-51	1
2	Washer High Tensile 1 3/8"	0232-HT13-8	1
3	M12 x 80 Class 8.8 ZP Bolt	0211-1280	1
4	Nyloc Nut M12	0221-NYL12	1

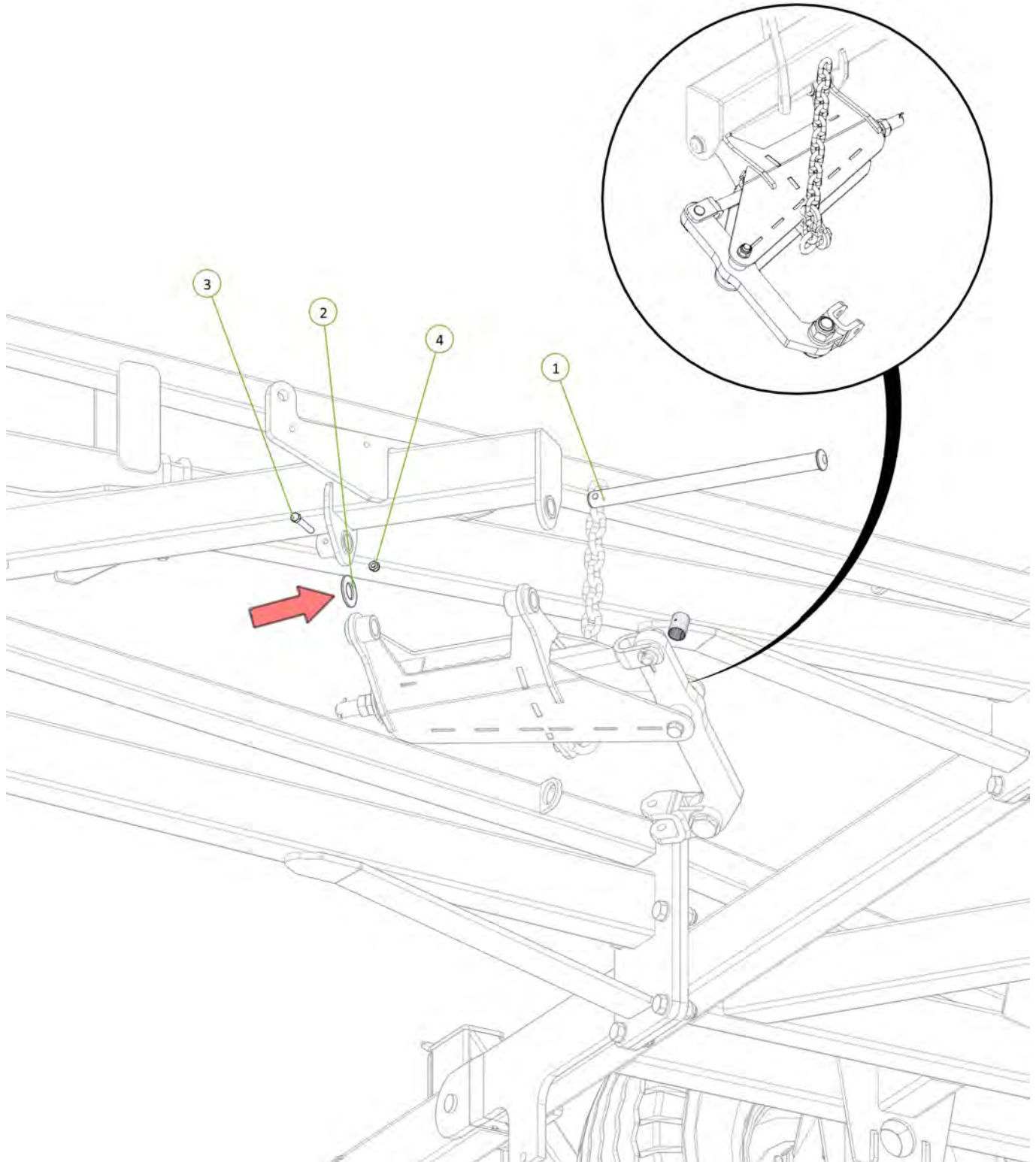

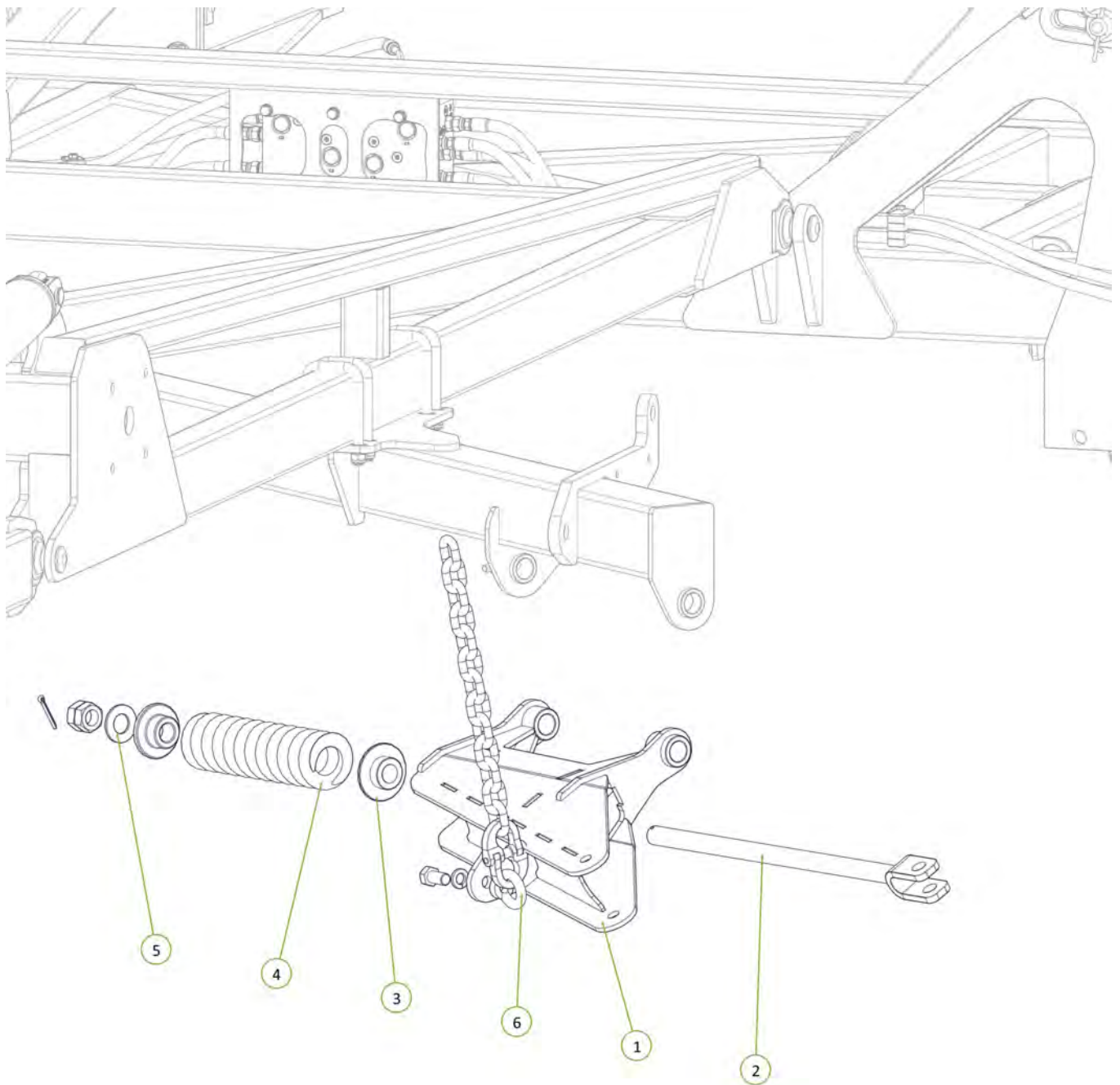

Item No.	Description	Number	Qty
1	Tension Box	0810-57	1
2	Module Tension Rod Assembly	0810-105A	1
3	Rigid Spring Locator	0801-10-S2L	1
4	Heavy Duty Coil Spring 24mm	0801-K2455350	1
5	Washer High Tensile 1 1/4"	0232-HT11-4	1
6	Height Adjusting Chain Assembly 13 Link	0801-20MCA	1



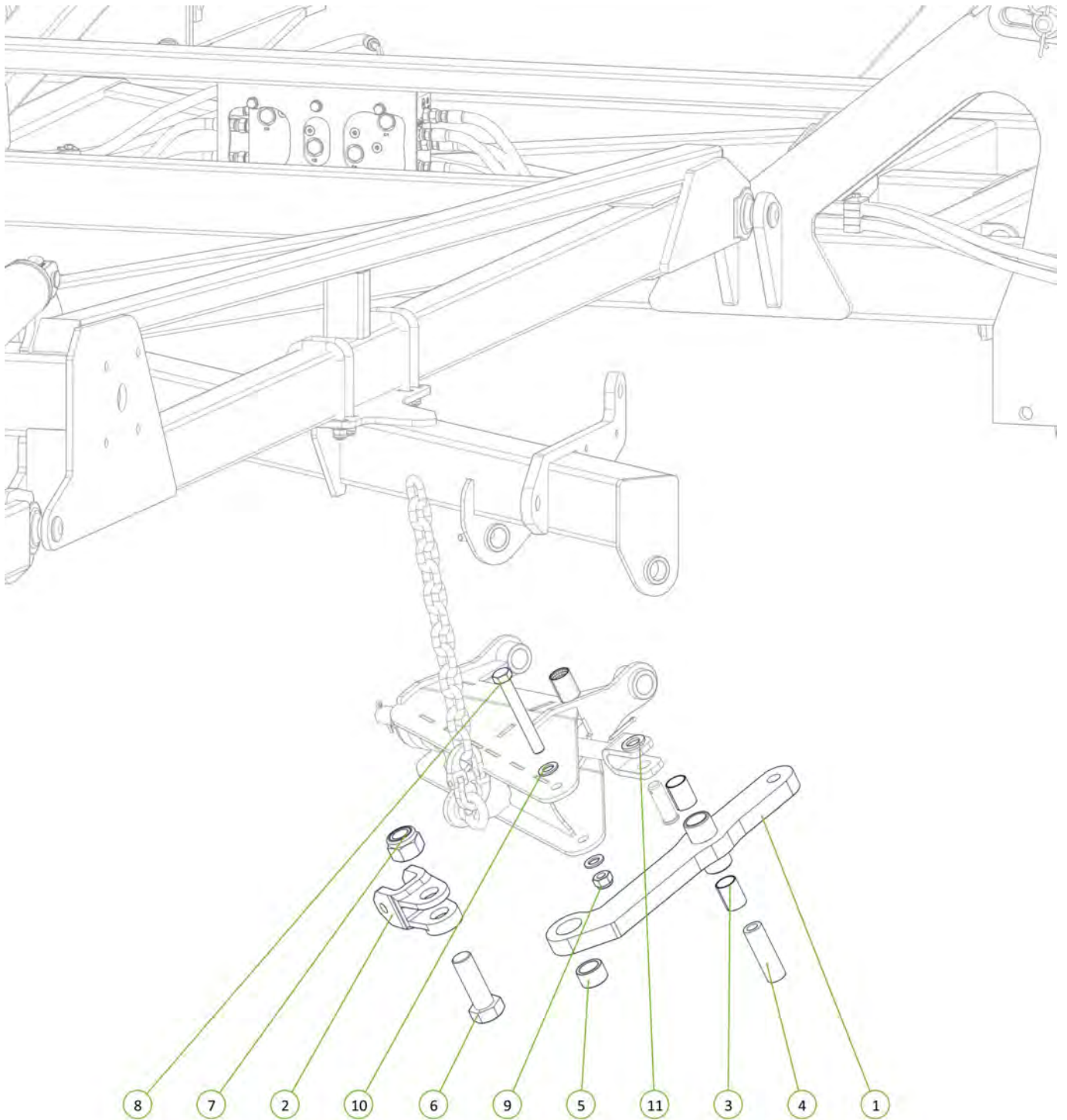

Item No.	Description	Number	Qty
1	Module Tension Arm No Clevis	0810-104F	1
2	Forged Clevis 21mm Bolt Hole	0801-FC21	1
3	35 ID x 50mm DU Bush	0113-MB3550DU	2
4	Module Pivot Arm Bush	0801-10-110	1
5	Wear Bush	1501-365033-SS	1
6	M36 x 105 Class 8.8 ZP Bolt	0211-36105	1
7	Nyloc Nut M36	0221-NYL36	1
8	M20 x 160 Class 8.8 ZP Bolt	0211-20160	1
9	Nyloc Nut M20	0221-NYL20	1
10	Washer Flat M20	0231-F20	2
11	Washer Flat M24	0231-F24	1



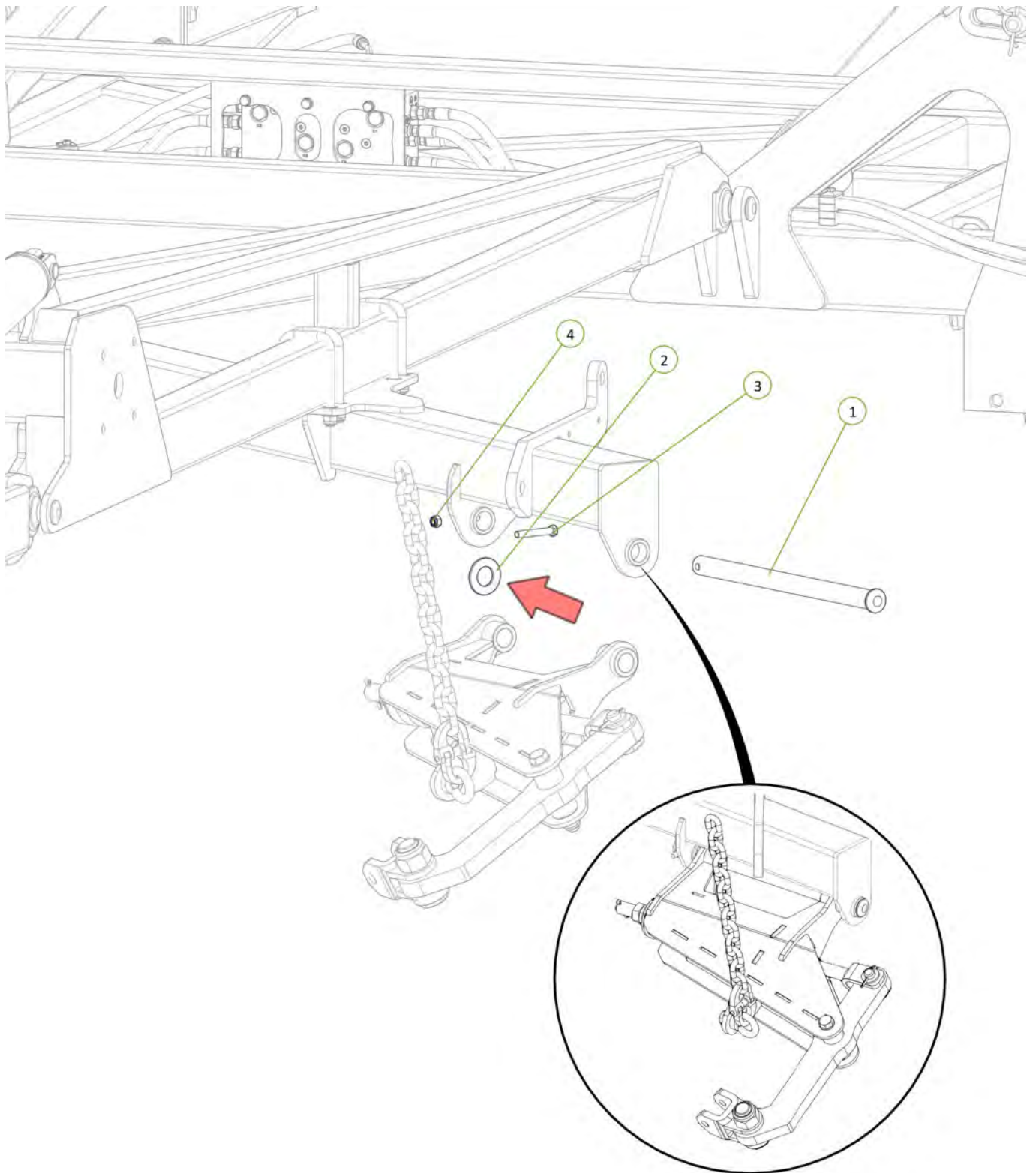

Item No.	Description	Number	Qty
1	Chain Mount Pivot Pin	0801-10-51	1
2	Washer High Tensile 1 3/8"	0232-HT13-8	1
3	M12 x 80 Class 8.8 ZP Bolt	0211-1280	1
4	Nyloc Nut M12	0221-NYL12	1



Item No.	Description	Number	Qty
1	Reduced Lift Arm	0810-84	1
2	Clevis Pin 25mm x 75mm	0801-KE0307-1	1
3	Height Adjustor Retaining Clip	0801-KE014	1
4	Washer Flat M24	0231-F24	1
5	Cotter Pin M5 x 50	0261-PINC550	1

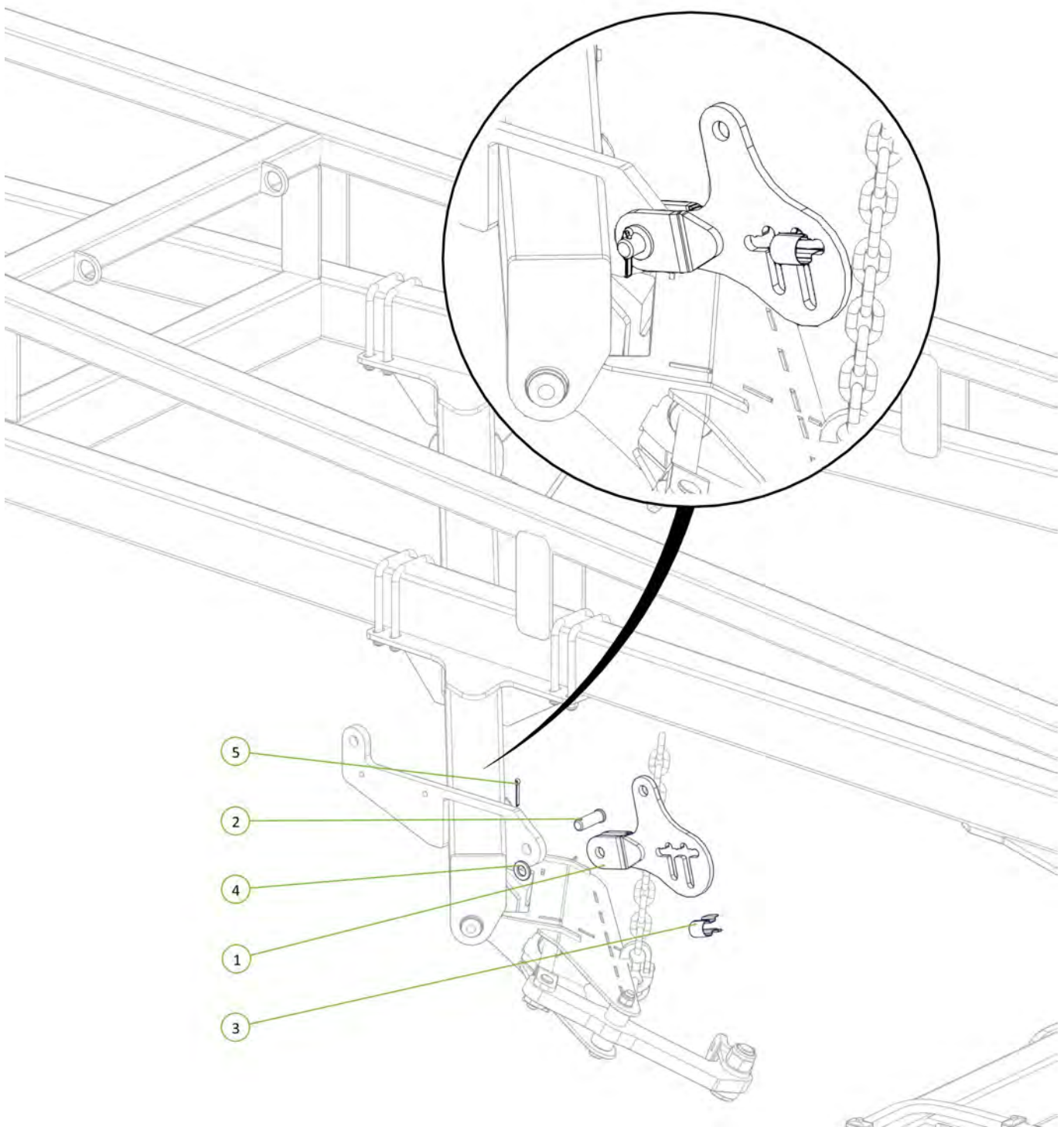

Item No.	Description	Number	Qty
1	2.5" Bore x 6" Stroke 1.5" Rod Side Port Cylinder	0311-256SP	1

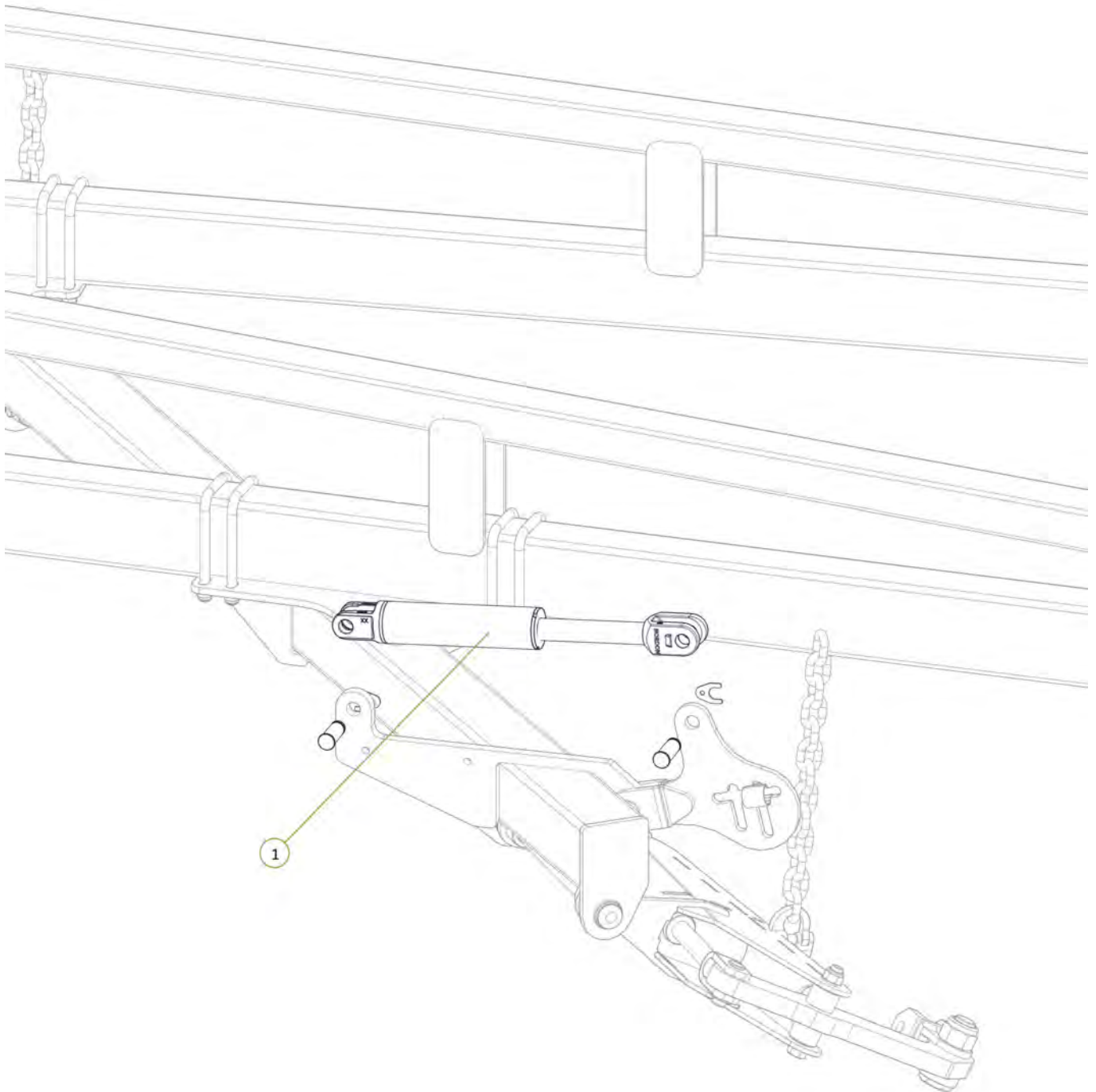
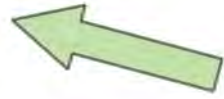

Item No.	Description	Number	Qty
1	3/4" JIC Male 3/4" UN O Ring Male 45° Elbow	0323-S88-1212	2

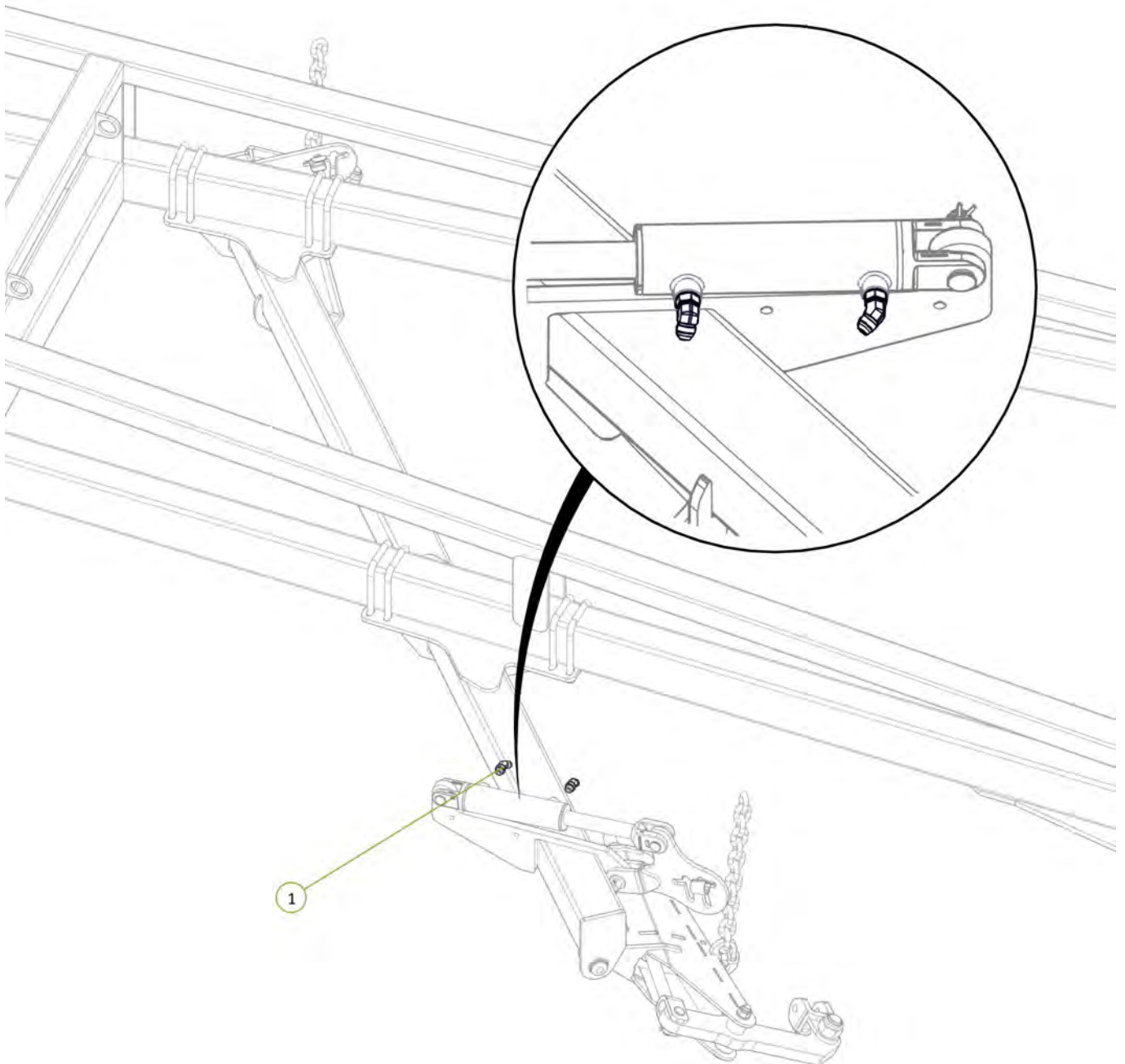
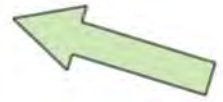

Item No.	Description	Number	Qty
1	ME2 Port to Front Module Lift Cylinder Extend Port	PH40-14	1
2	MR2 Port to Front Module Lift Cylinder Retract Port	PH40-15	1

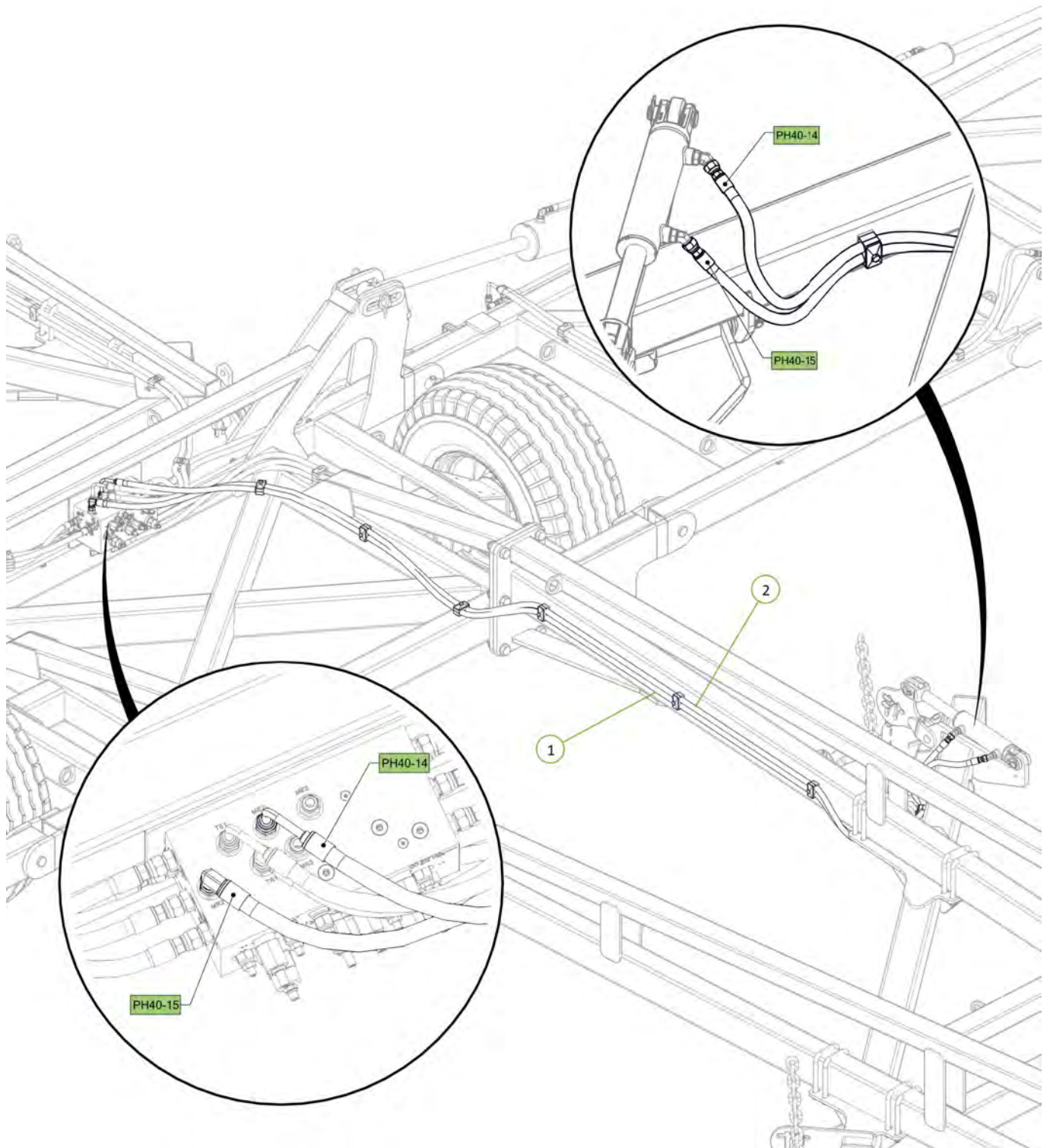

Item No.	Description	Number	Qty
1	Reduced Lift Arm	0810-84	1
2	Clevis Pin 25mm x 75mm	0801-KE0307-1	1
3	Washer Flat M24	0231-F24	1
4	Height Adjustor Retaining Clip	0801-KE014	1
5	Cotter Pin M5 x 50	0261-PINC550	1

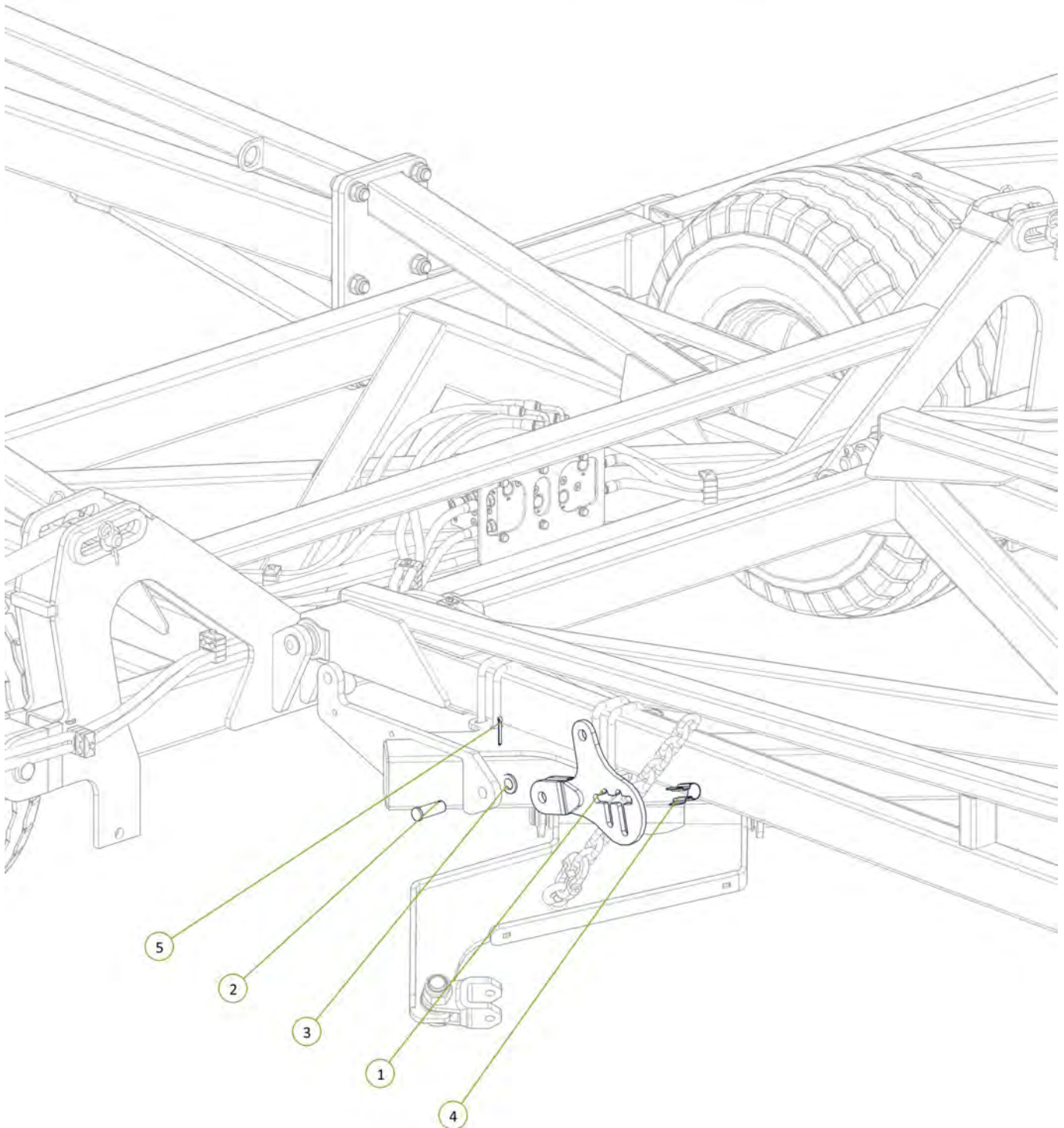

Item No.	Description	Number	Qty
1	2.5" Bore x 6" Stroke 1.5" Rod Side Port Cylinder	0311-256SP	1

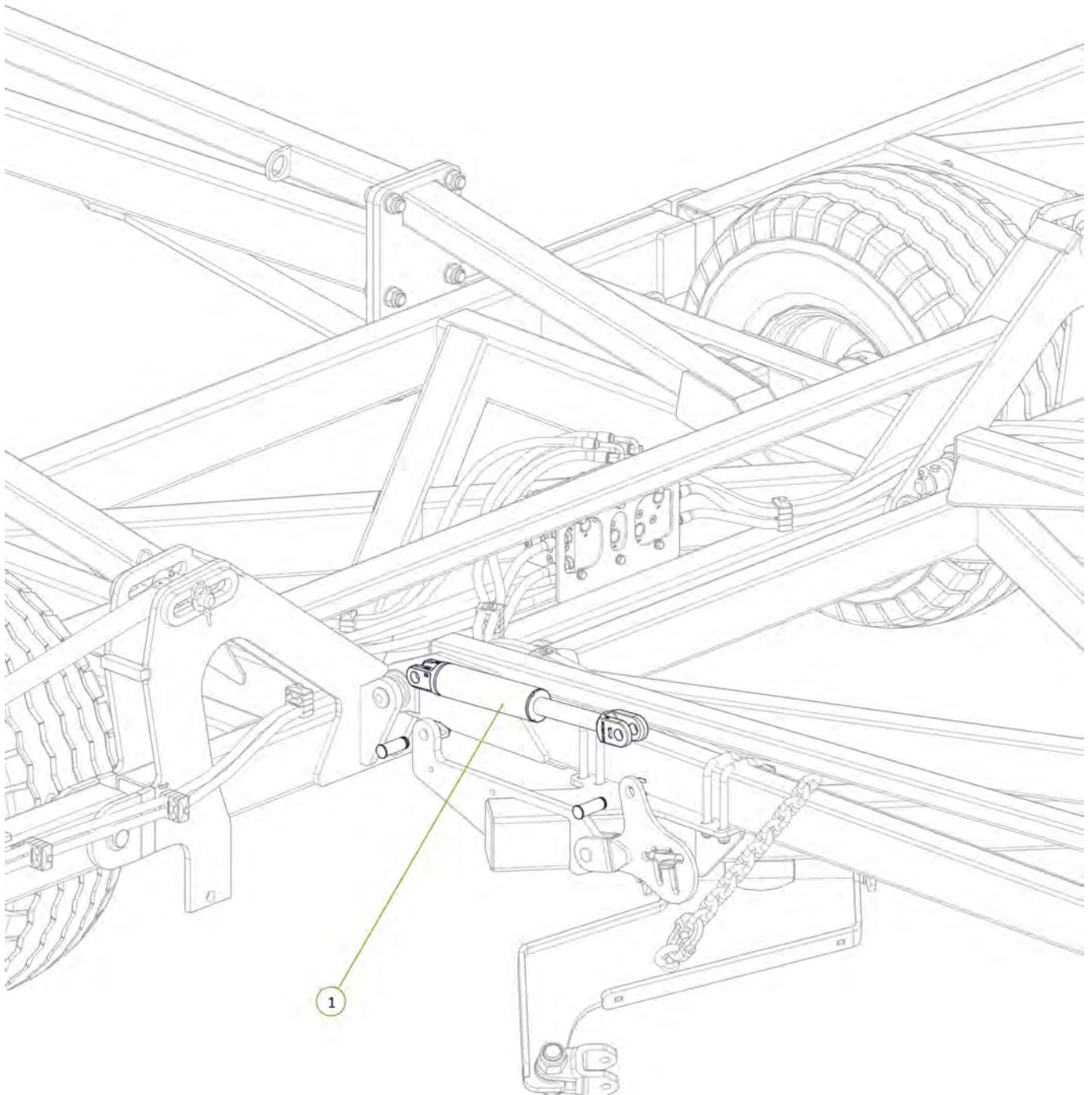

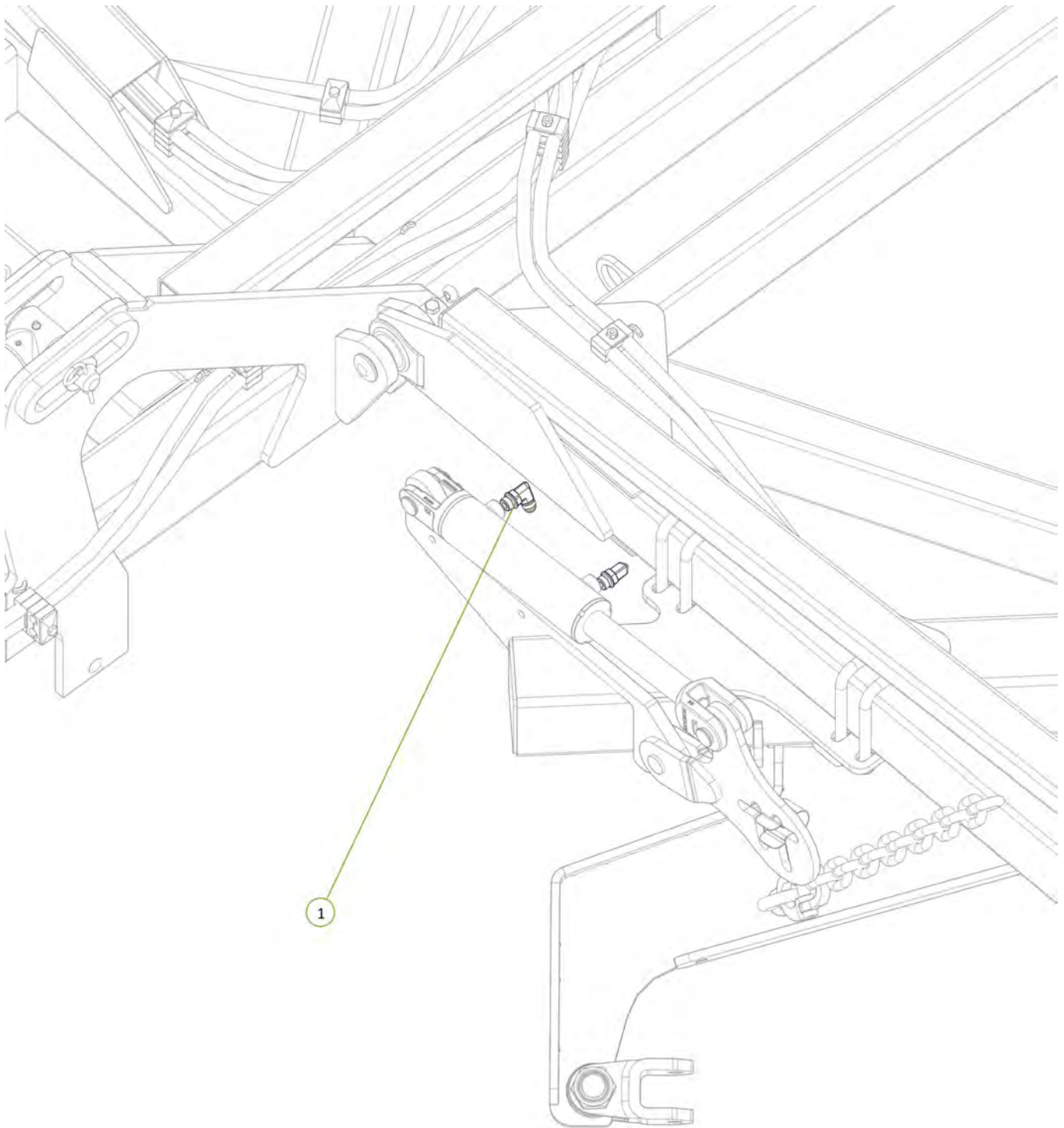

Item No.	Description	Number	Qty
1	3/4" JIC Male 3/4" UN O Ring Male 90° Elbow	0323-S91-1212	2



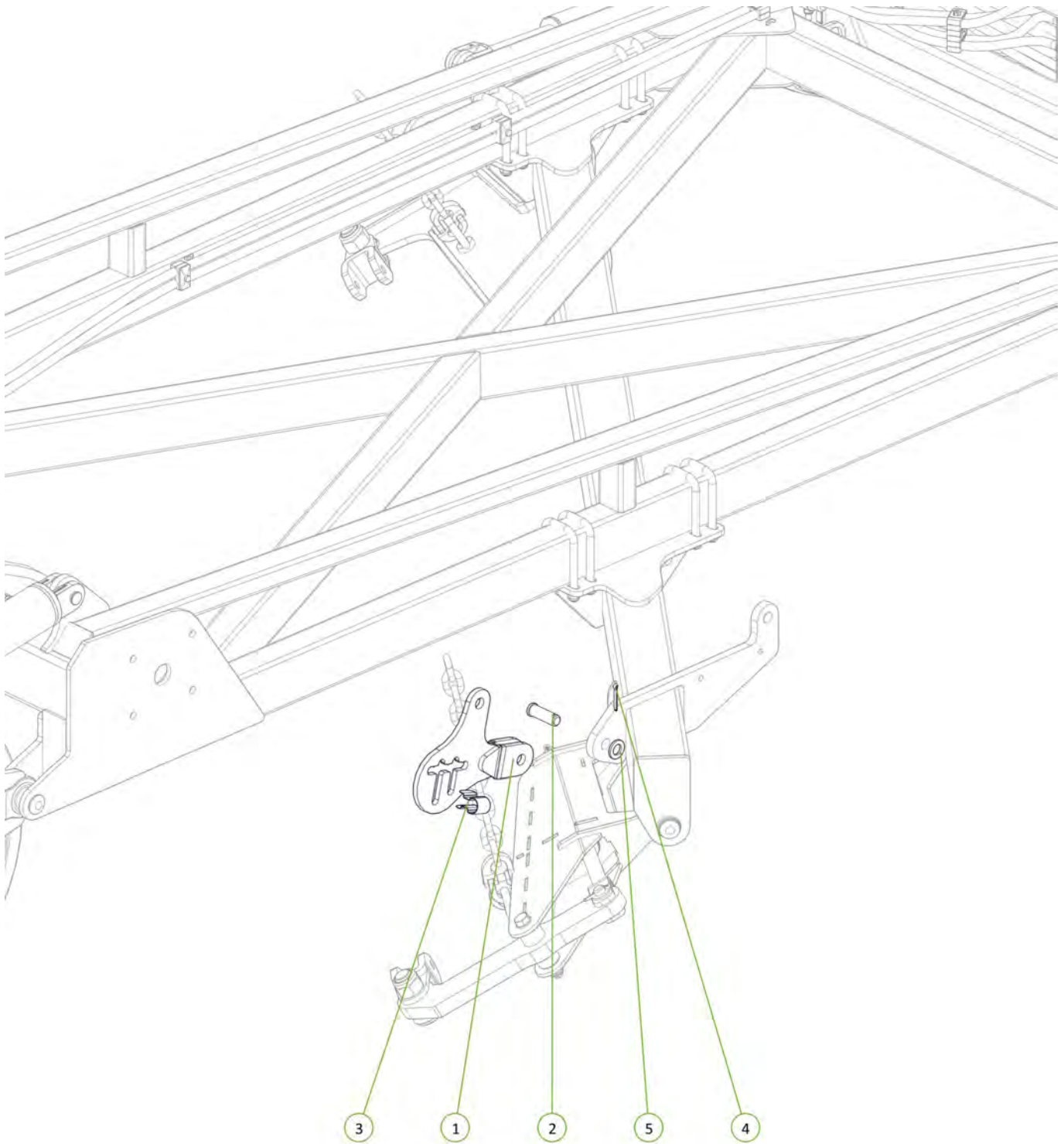

Item No.	Description	Number	Qty
1	Reduced Lift Arm	0810-84	1
2	Clevis Pin 25mm x 75mm	0801-KE0307-1	1
3	Height Adjustor Retaining Clip	0801-KE014	1
4	Cotter Pin M5 x 50	0261-PINC550	1
5	Washer Flat M24	0231-F24	1



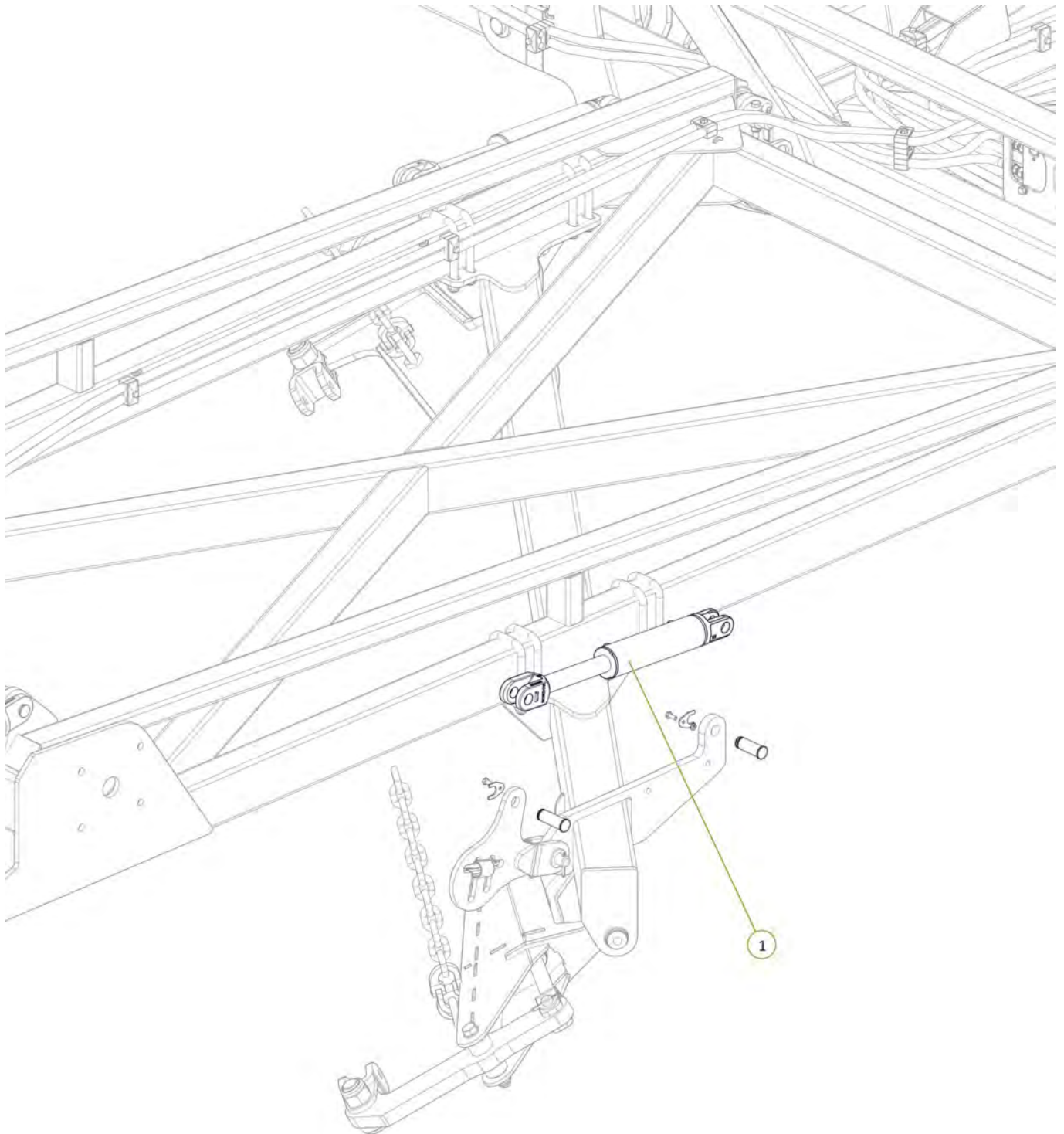

Item No.	Description	Number	Qty
1	2.5" Bore x 6" Stroke 1.5" Rod Side Port Cylinder	0311-256SP	1

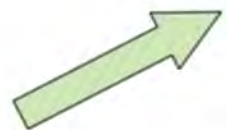

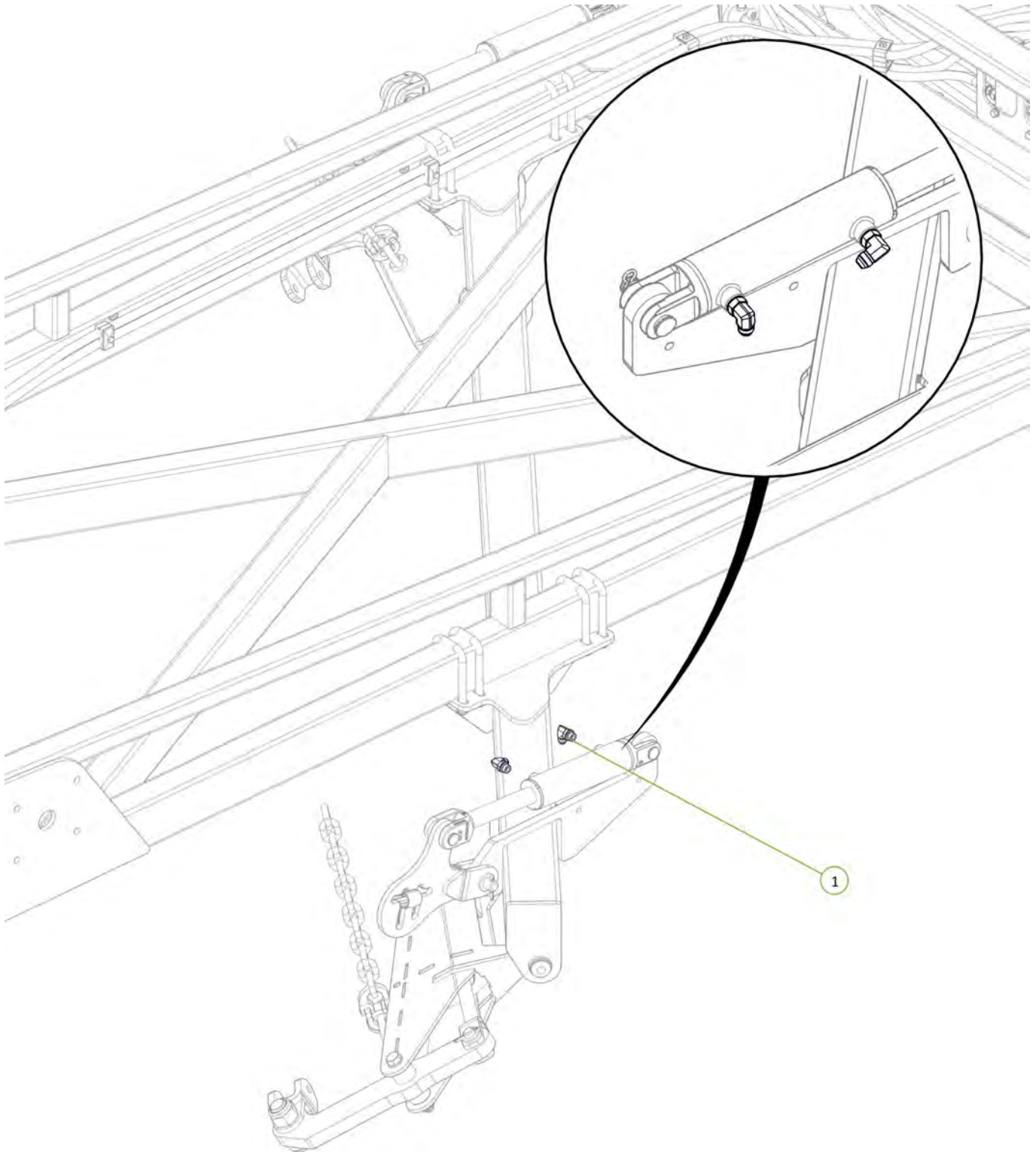

Item No.	Description	Number	Qty
1	3/4" JIC Male 3/4" UN O Ring Male 90° Elbow	0323-S91-1212	2



Item No.	Description	Number	Qty
1	ME3 Port to Rear Module Extend Tee	PH40-24	1
2	MR3 Port to Rear Module Retract Tee	PH40-25	1
3	3/4" JIC Male Tee 3/4" JIC Male Tee 3/4" JIC Male Tee	0324-S19-121212	2

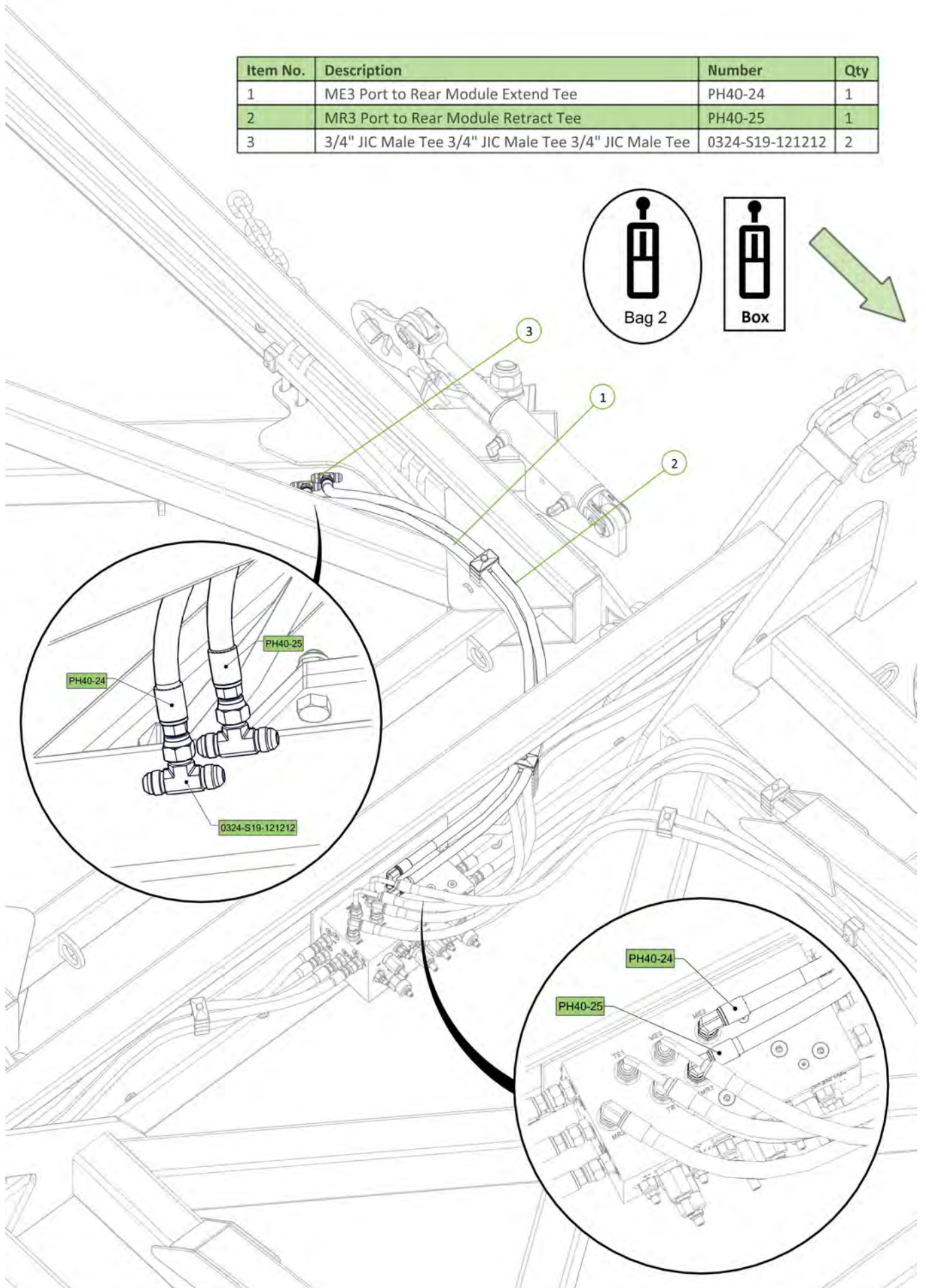

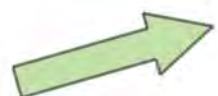
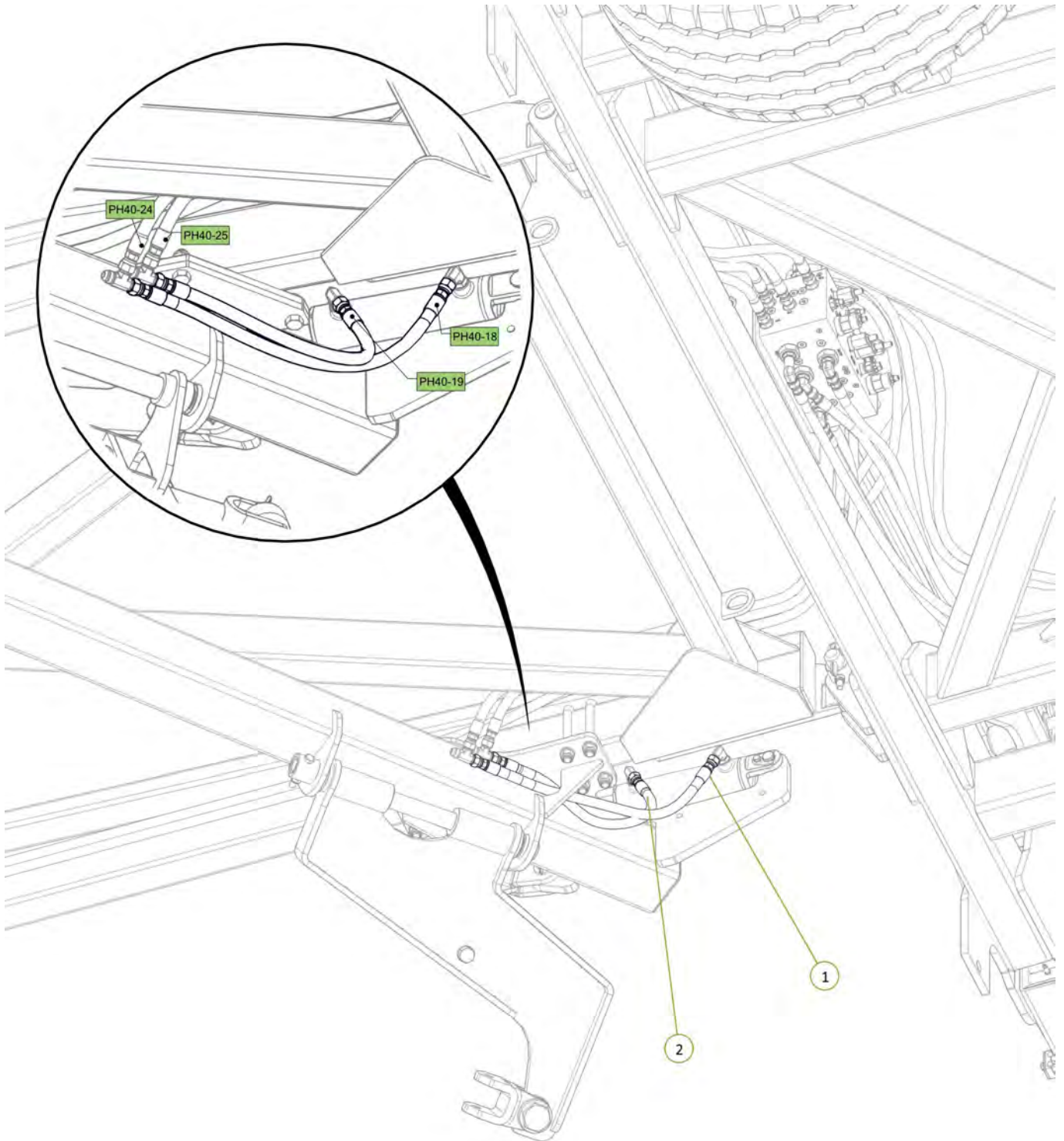

Item No.	Description	Number	Qty
1	Rear Module Extend Tee to LH Module Lift Cylinder Extend Port	PH40-18	1
2	Rear Module Retract Tee to LH Module Lift Cylinder Retract Port	PH40-19	1



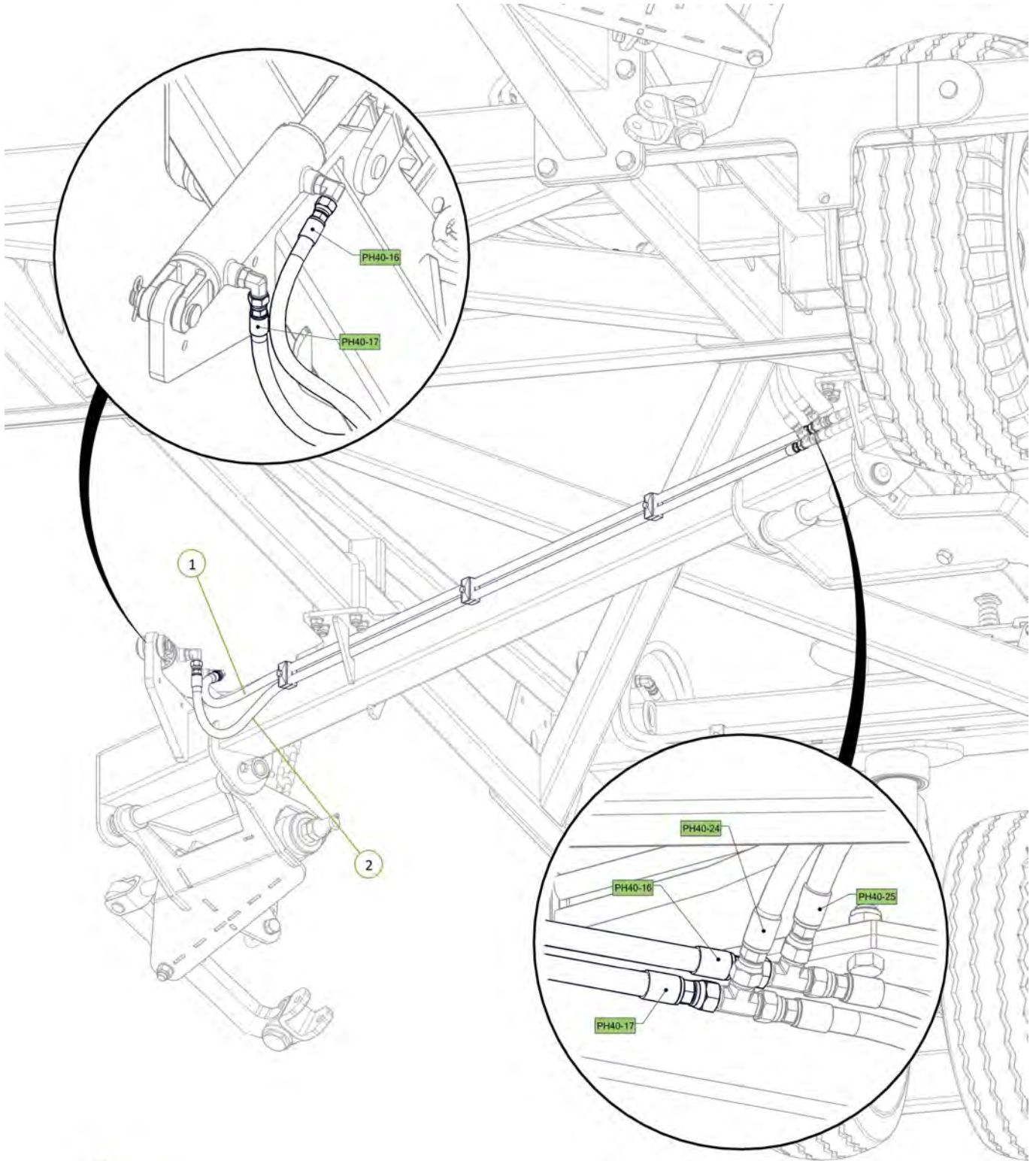

Item No.	Description	Number	Qty
1	Rear Module Retract Tee to Right Rear Module Lift Cylinder Retract Port	PH40-16	1
2	Rear Module Extend Tee to Right Rear Module Lift Cylinder Extend Port	PH40-17	1



Item No.	Description	Number	Qty
1	40" Chain Carrier Beam	0810-17-40	1
2	Chain Carrier Mount Plate	0800-139.1	2
3	U-Bolt M16 x 162 Deep x 129 Wide	0271-16160127	4
4	U-Bolt M16 x 114 Deep x 106 Wide	0271-16112104	4
5	Nyloc Nut M16	0221-NYL16	16
6	Washer Flat M16	0231-F16	16

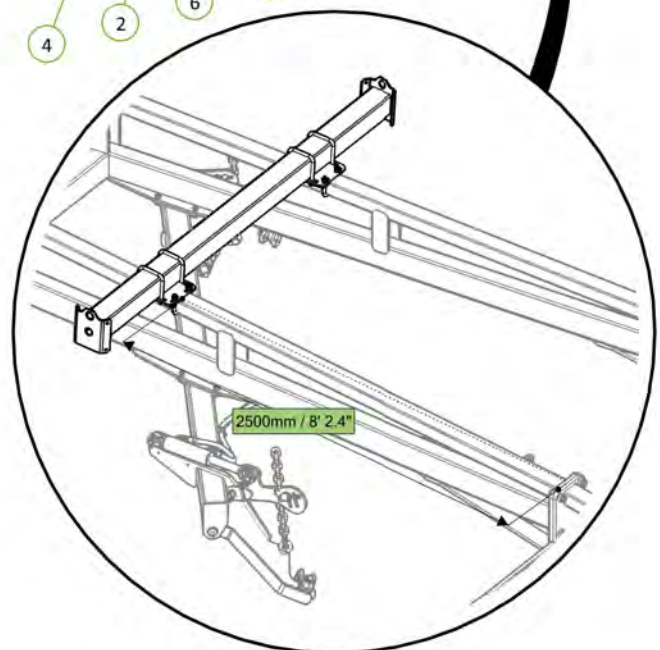
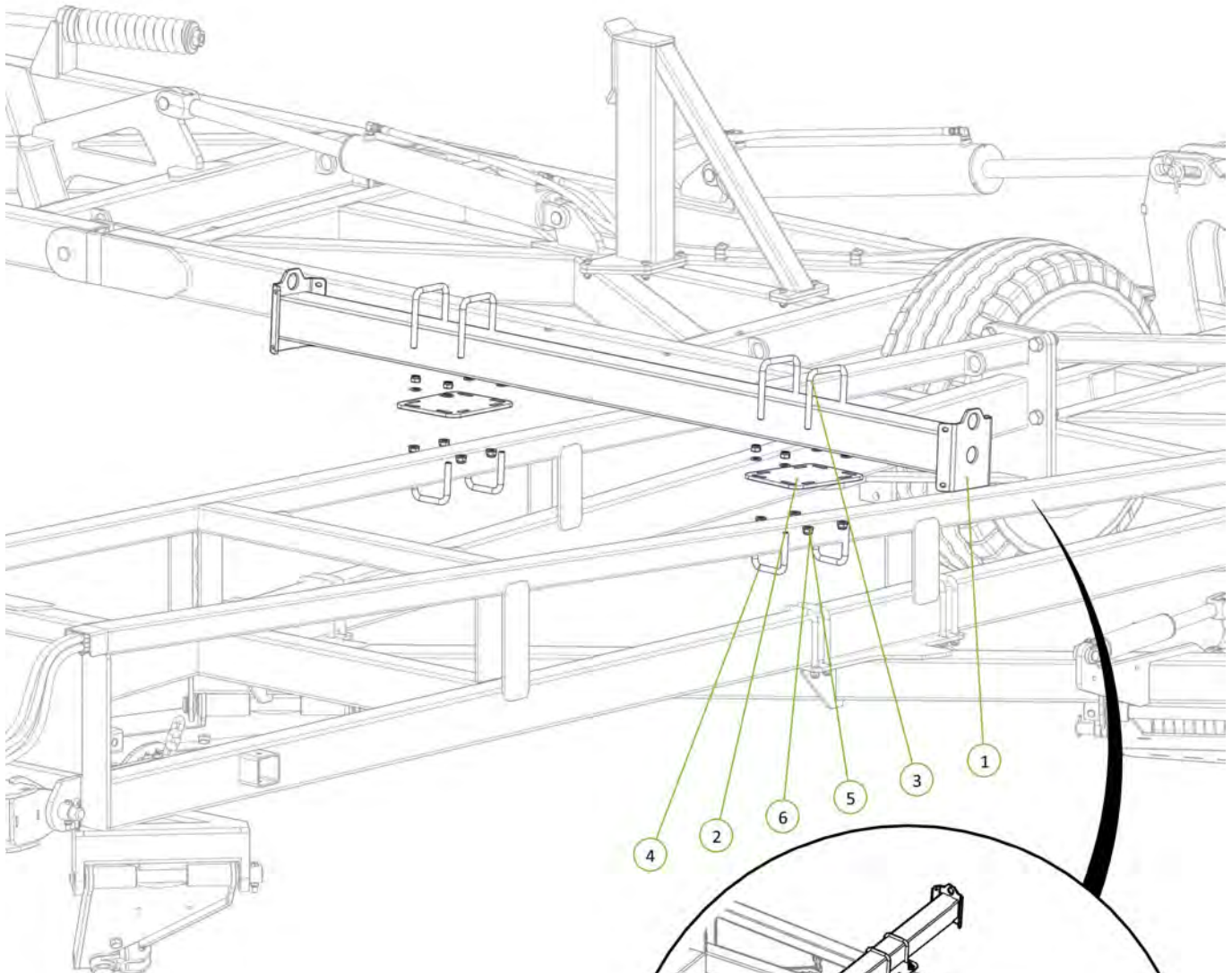

Item No.	Description	Number	Qty
1	Extended Chain Carrier Bolt on End	0810-17LE	2
2	M12 x 40 Coach Head Bolt	0215-CH1240	8
3	Nyloc Nut M12	0221-NYL12	8
4	Washer Flat M12	0231-F12	8

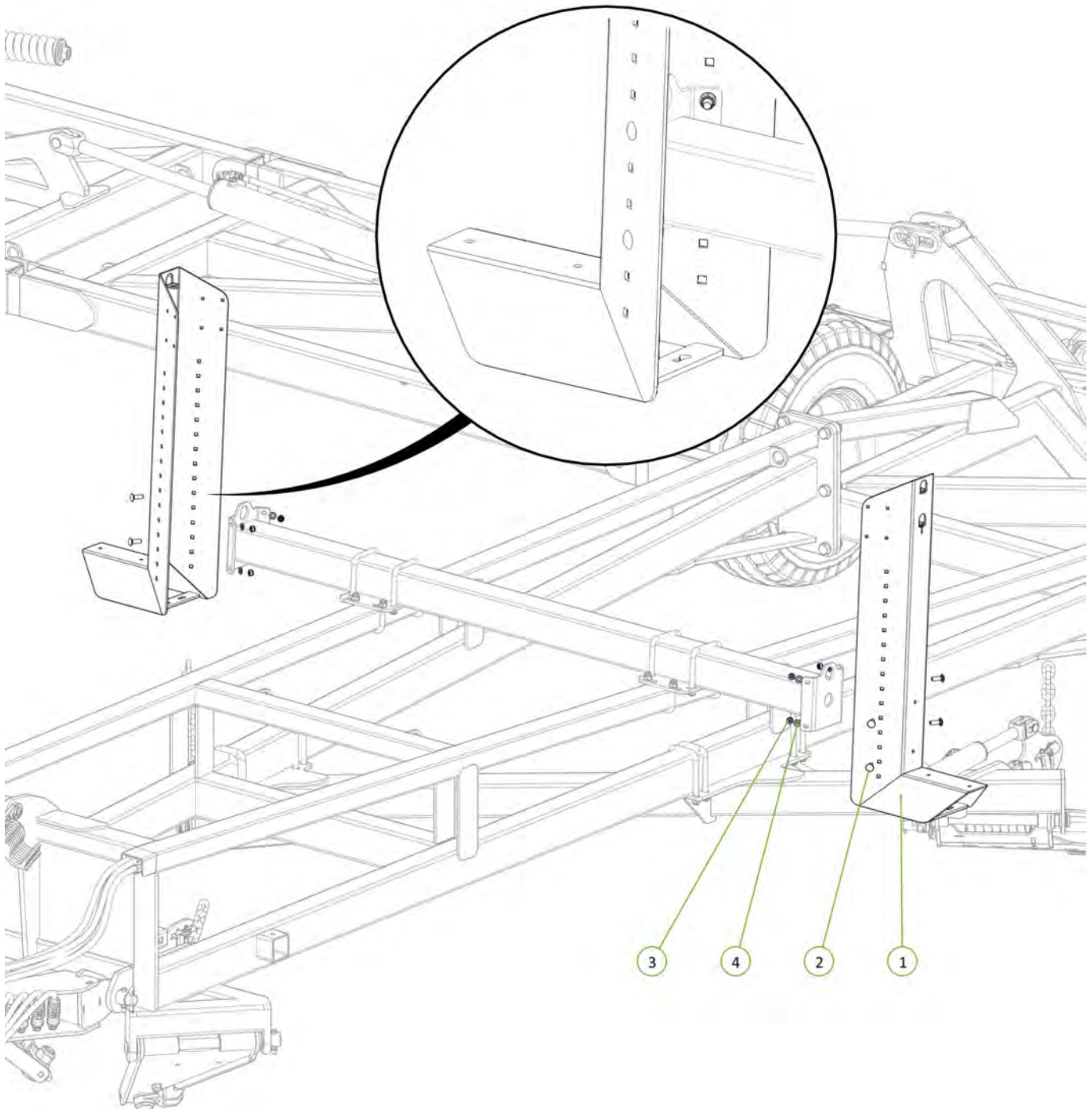

Item No.	Description	Number	Qty
1	40" Chain Carrier Beam	0810-17-40	1
2	Chain Carrier Pedestal 300mm	1510-43	2
3	U-Bolt M16 x 87 Deep X 79 Wide	0271-168577	4
4	U-Bolt M16 x 162 Deep x 129 Wide	0271-16160127	4
5	Nyloc Nut M16	0221-NYL16	16
6	Washer Flat M16	0231-F16	16

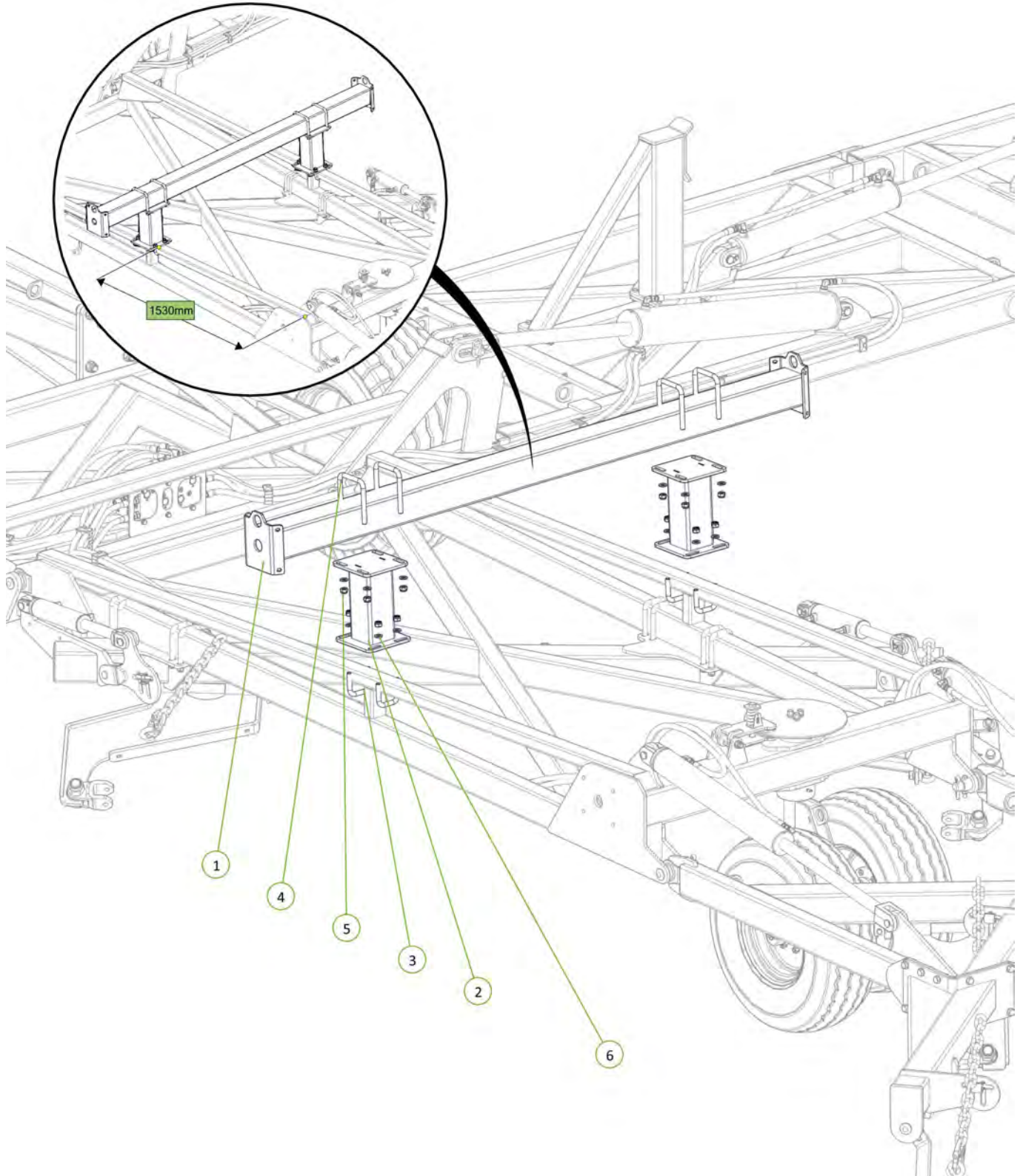

Item No.	Description	Number	Qty
1	Extended Chain Carrier Bolt on End	0810-17LE	2
2	M12 x 40 Coach Head Bolt	0215-CH1240	8
3	Nyloc Nut M12	0221-NYL12	8
4	Washer Flat M12	0231-F12	8

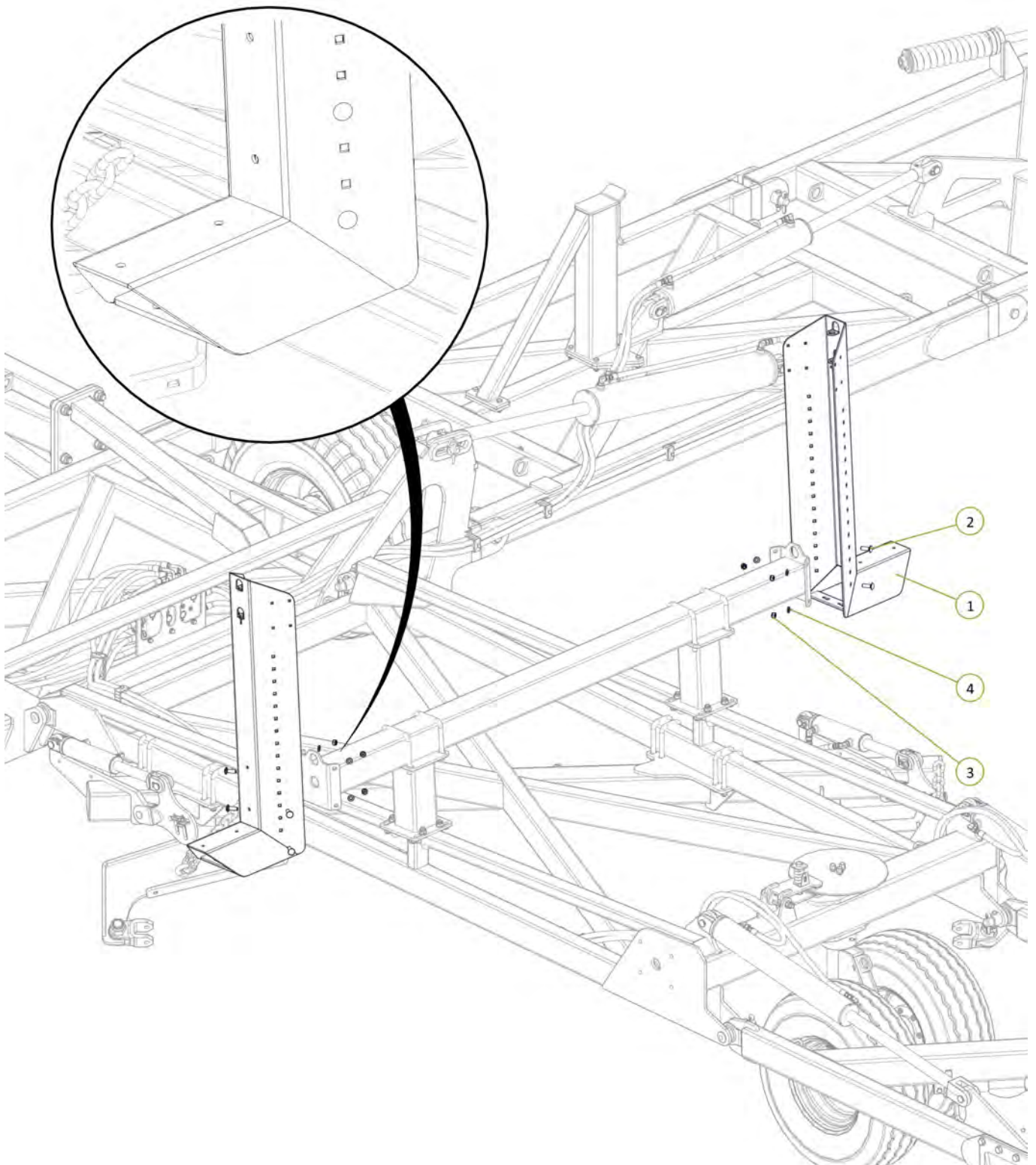

Item No.	Description	Number	Qty
1	30' & 40' Outrigger	0810-40	2
2	M16 x 55 Class 8.8 ZP Bolt	0211-1655	8
3	Nyloc Nut M16	0221-NYL16	8
4	Washer Flat M16	0231-F16	16

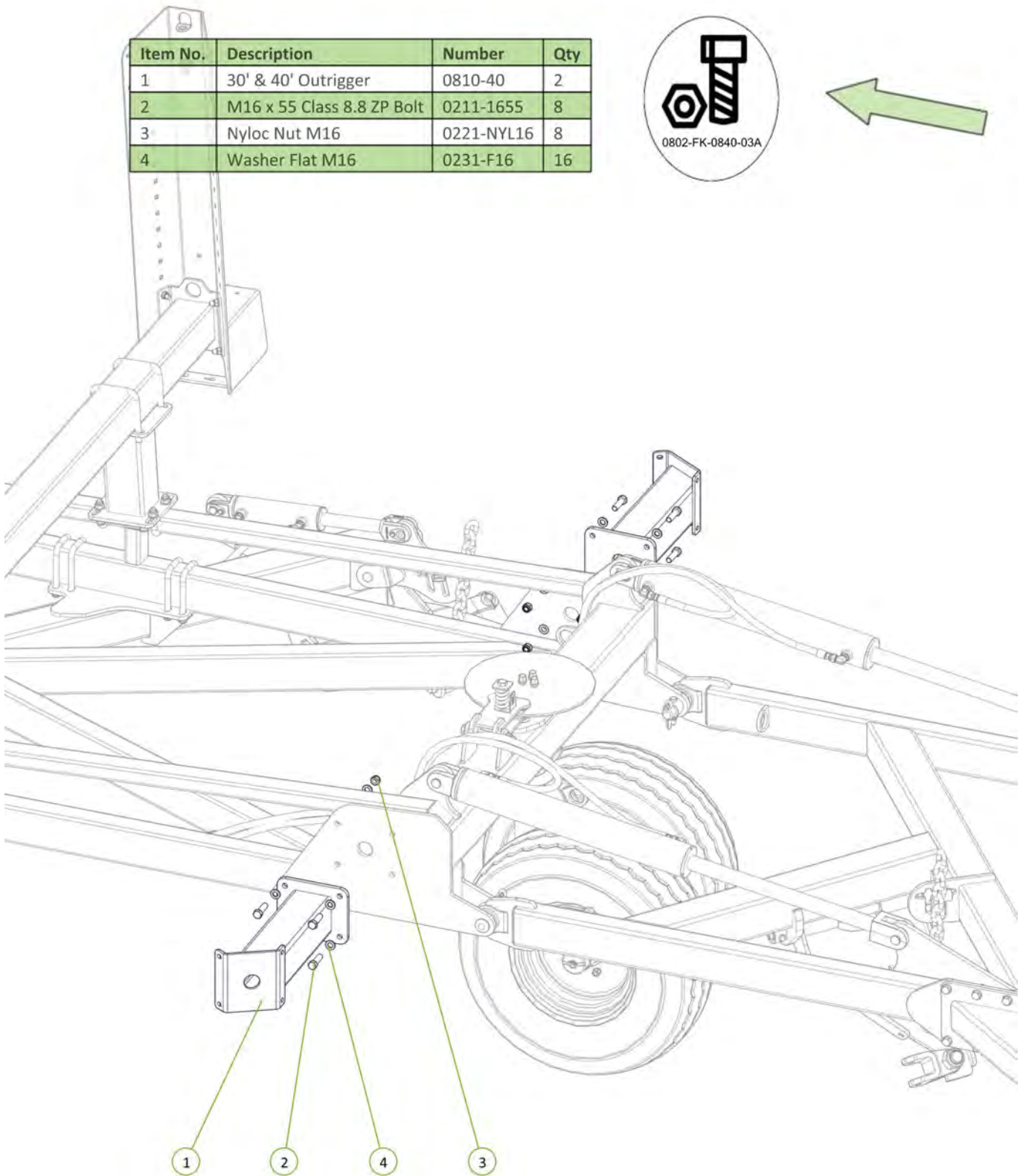

Item No.	Description	Number	Qty
1	Extended Chain Carrier Bolt on End	0810-17LE	2
2	M12 x 40 Coach Head Bolt	0215-CH1240	8
3	Nyloc Nut M12	0221-NYL12	8
4	Washer Flat M12	0231-F12	8

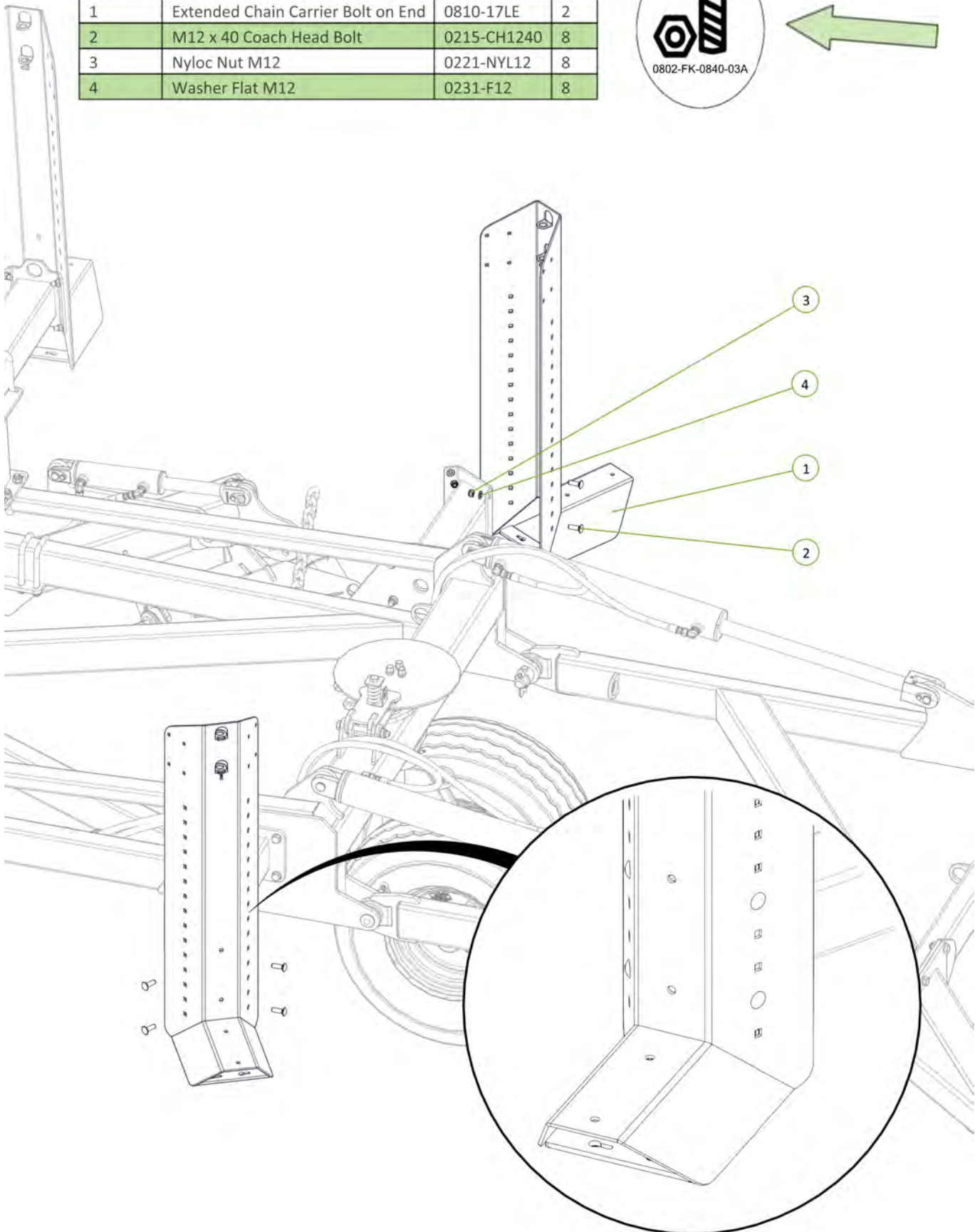

Item No.	Description	Number	Qty
1	Left Hand M	0810-19L	1
2	Right Hand M	0810-18R	1
3	U-Bolt M12 x 107 Deep x 106 Wide	0271-12105104	4
4	Round Tube Insert 60.3 x 3.2-5mm	0264-RTRi-5584	4
5	Nyloc Nut M12	0221-NYL12	8
6	Washer Flat M12	0231-F12	8

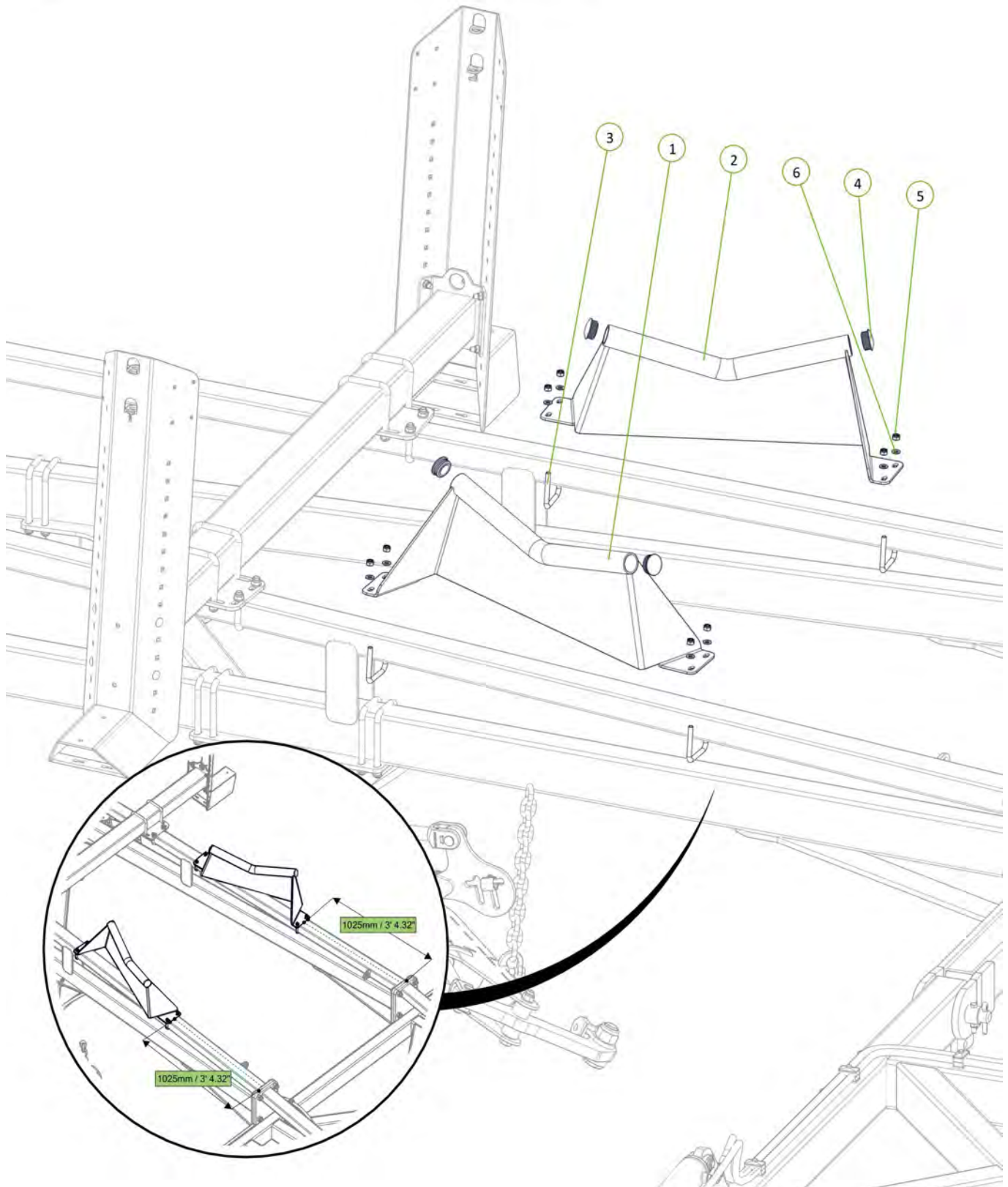

Item No.	Description	Number	Qty
1	Left Hand M	0810-19L	1
2	Right Hand M	0810-18R	1
3	Straight Chain Carrier M	0810-19	1
4	U-Bolt M12 x 82 Deep x 79 Wide	0271-128077	4
5	Round Tube Insert 60.3 x 3.2-5mm	0264-RTRI-5584	6
6	U-Bolt M12 x 157 Deep x 79 Wide	0271-1215577	2
7	Nyloc Nut M12	0221-NYL12	12
8	Washer Flat M12	0231-F12	12

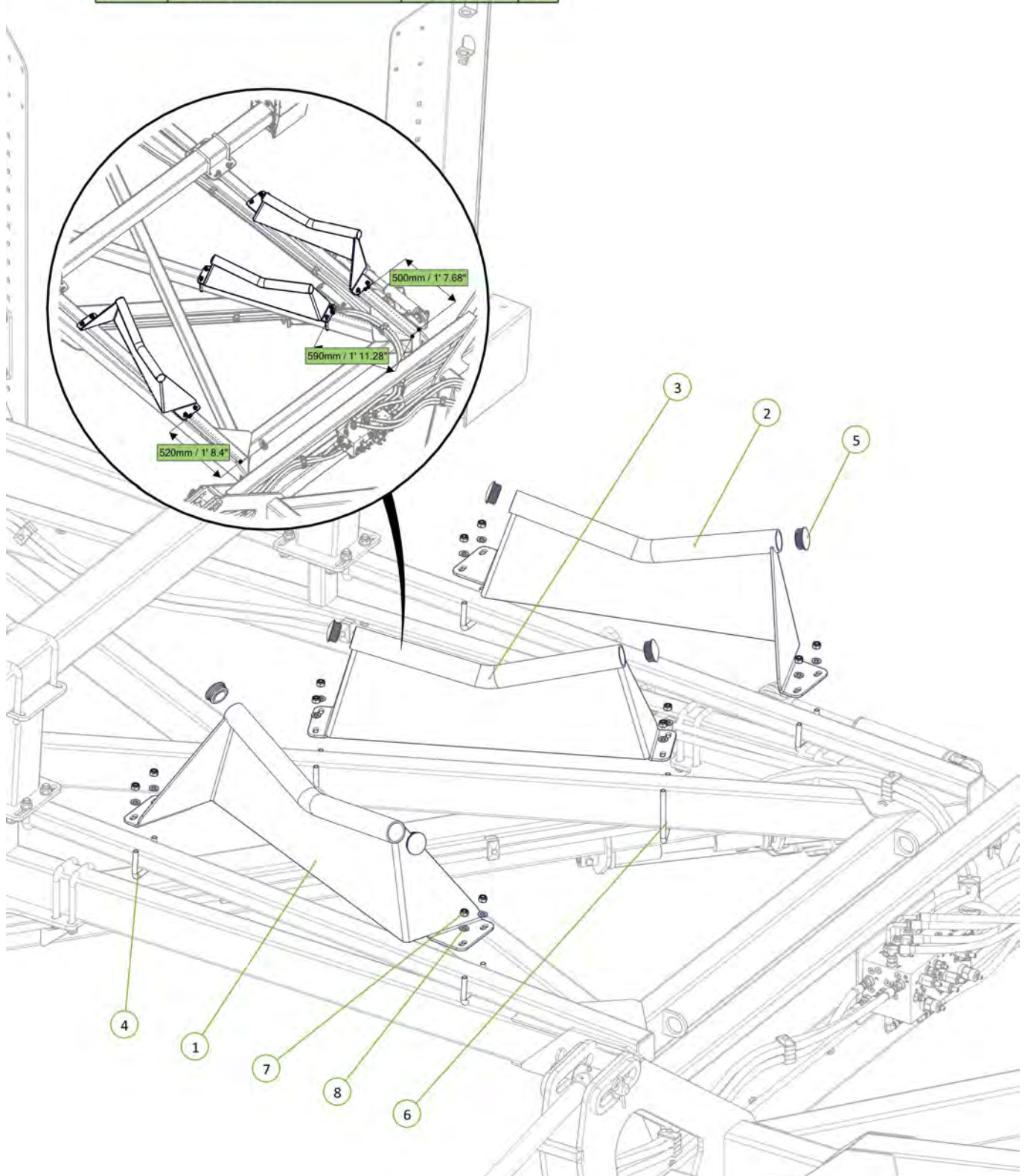

Item No.	Description	Number	Qty
1	AU Oversize Sign	0810-46	2
2	Oversize Sign Left Hand	0801-SIGNOSL	1
3	Oversize Sign Right Hand	0801-SIGNOSR	1
4	Washer Square M12 x 40 x 3	0231-SQ12403	6
5	M12 x 65 Coach Head Bolt	0215-CH1265	6
6	Nyloc Nut M12	0221-NYL12	6
7	TEK Screw 10g 16 x 16	0241-TEK10-1616	20

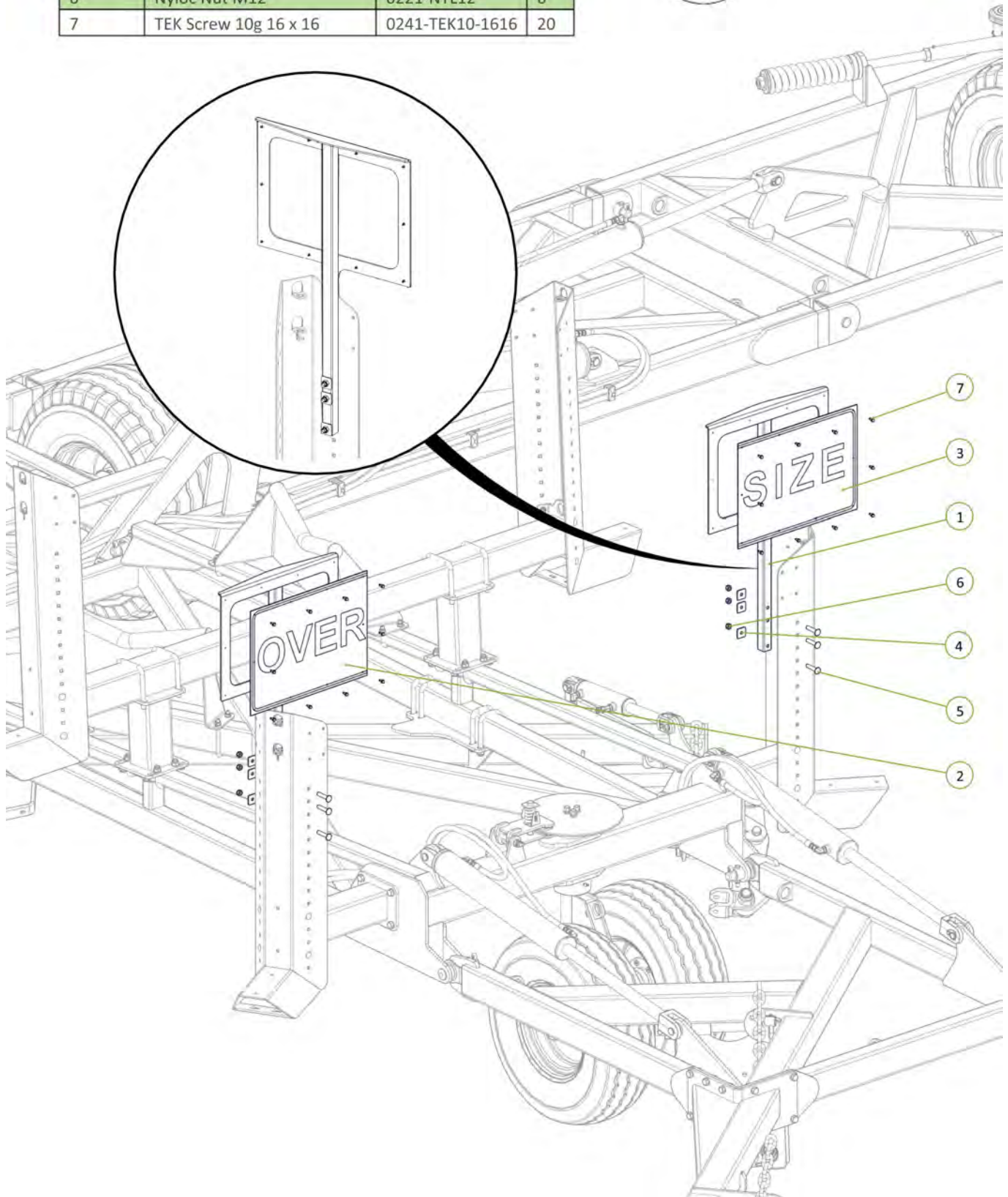

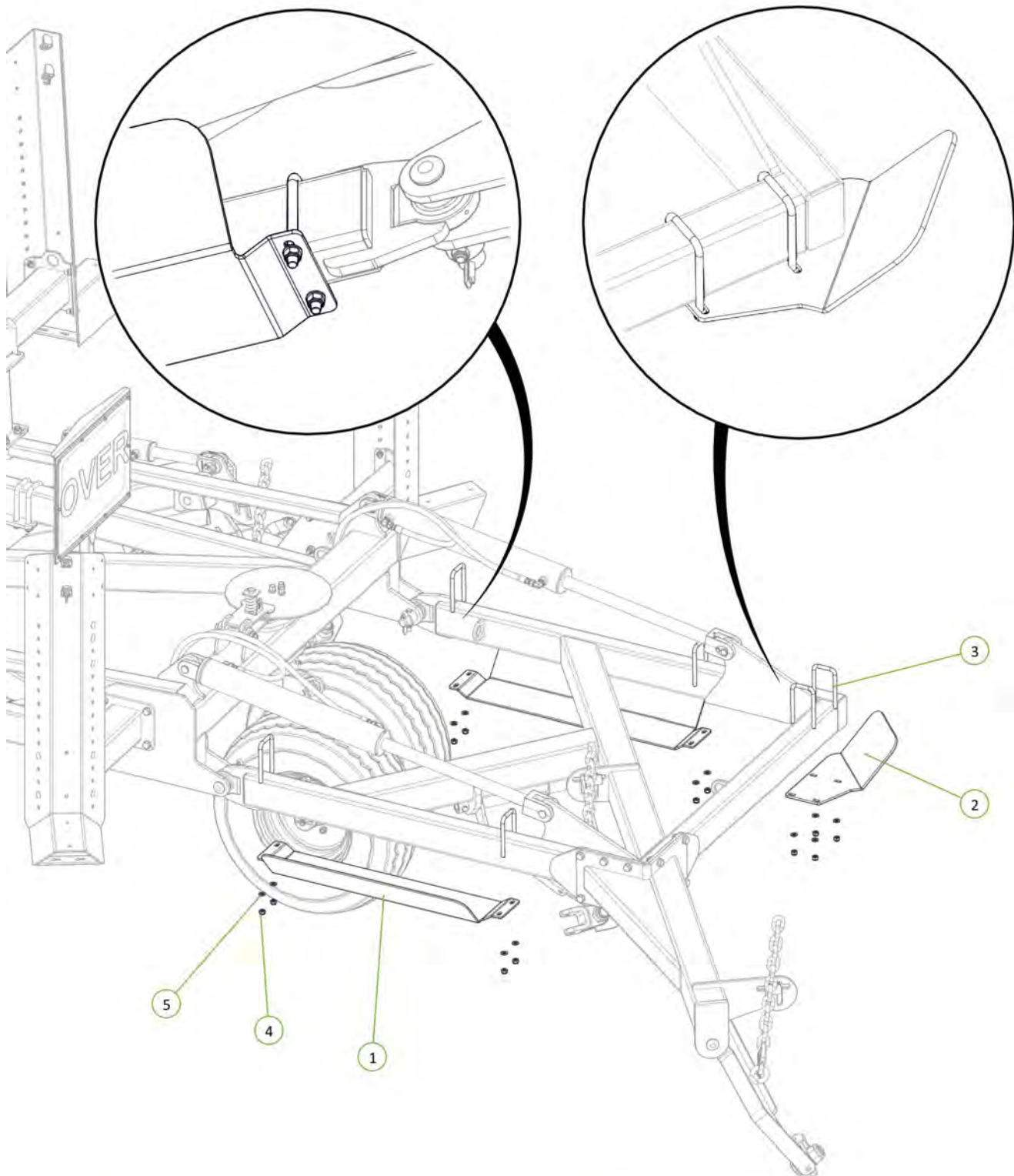

Item No.	Description	Number	Qty
1	Rear Tail Guard	0800-235	2
2	Angled Chain Gaurd	0800-498	1
3	U-Bolt M12 x 155 Deep x 77 Wide	0271-1215577	6
4	Nyloc Nut M12	0221-NYL12	12
5	Washer Flat M12	0231-F12	12



Item No.	Description	Number	Qty
1	Rear A-Frame Chain Shield	0800-230	1
2	U-Bolt M12 x 155 Deep x 77 Wide	0271-1215577	2
3	Nyloc Nut M12	0221-NYL12	4
4	Washer Flat M12	0231-F12	4

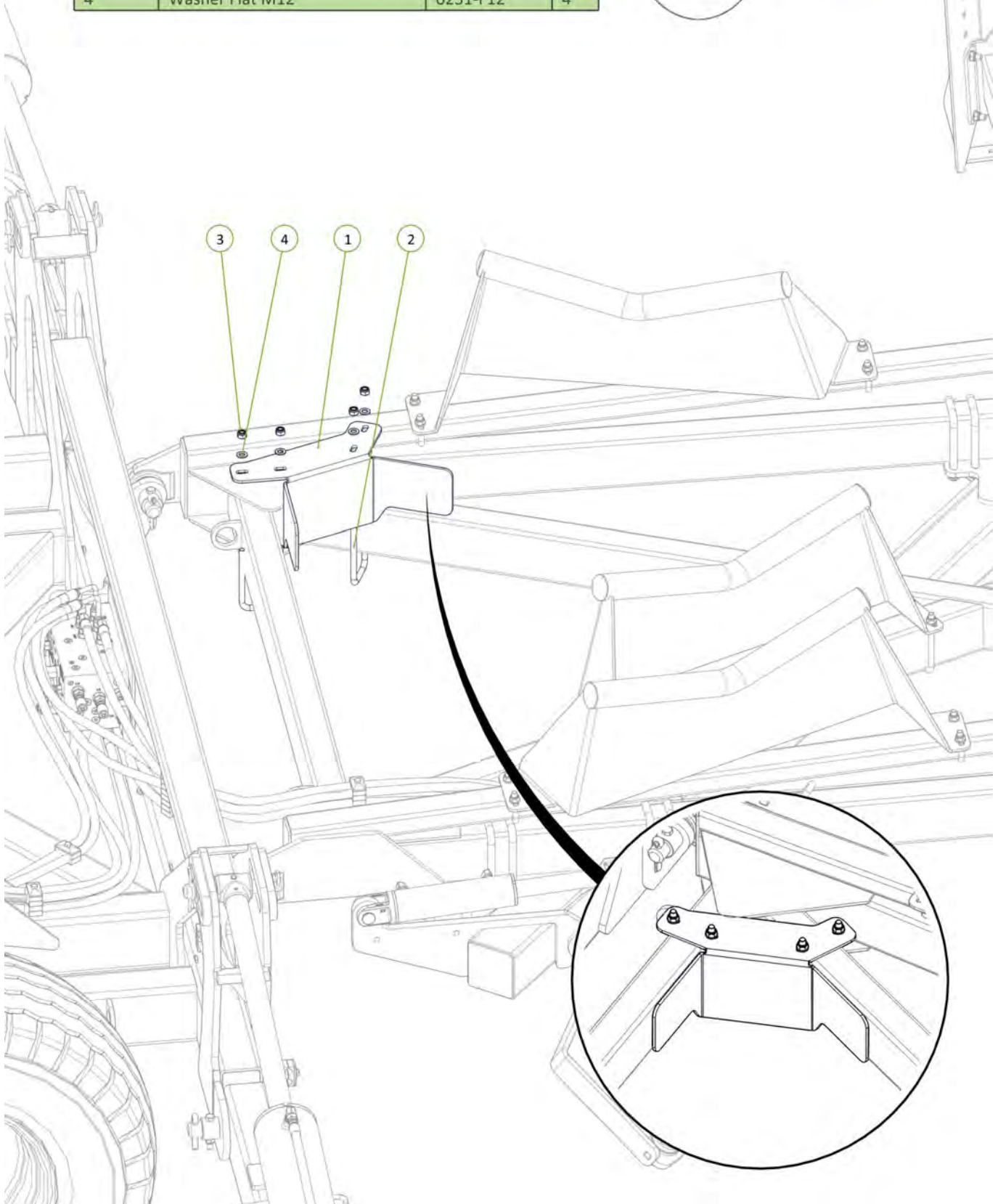

Item No.	Description	Number	Qty
1	Module Cylinder Guard	0800-167.3	1
2	M12 x 50 grade 8.8 ZP Bolt	0211-1250	2
3	Nyloc Nut M12	0221-NYL12	2
4	Washer Flat M12	0231-F12	4

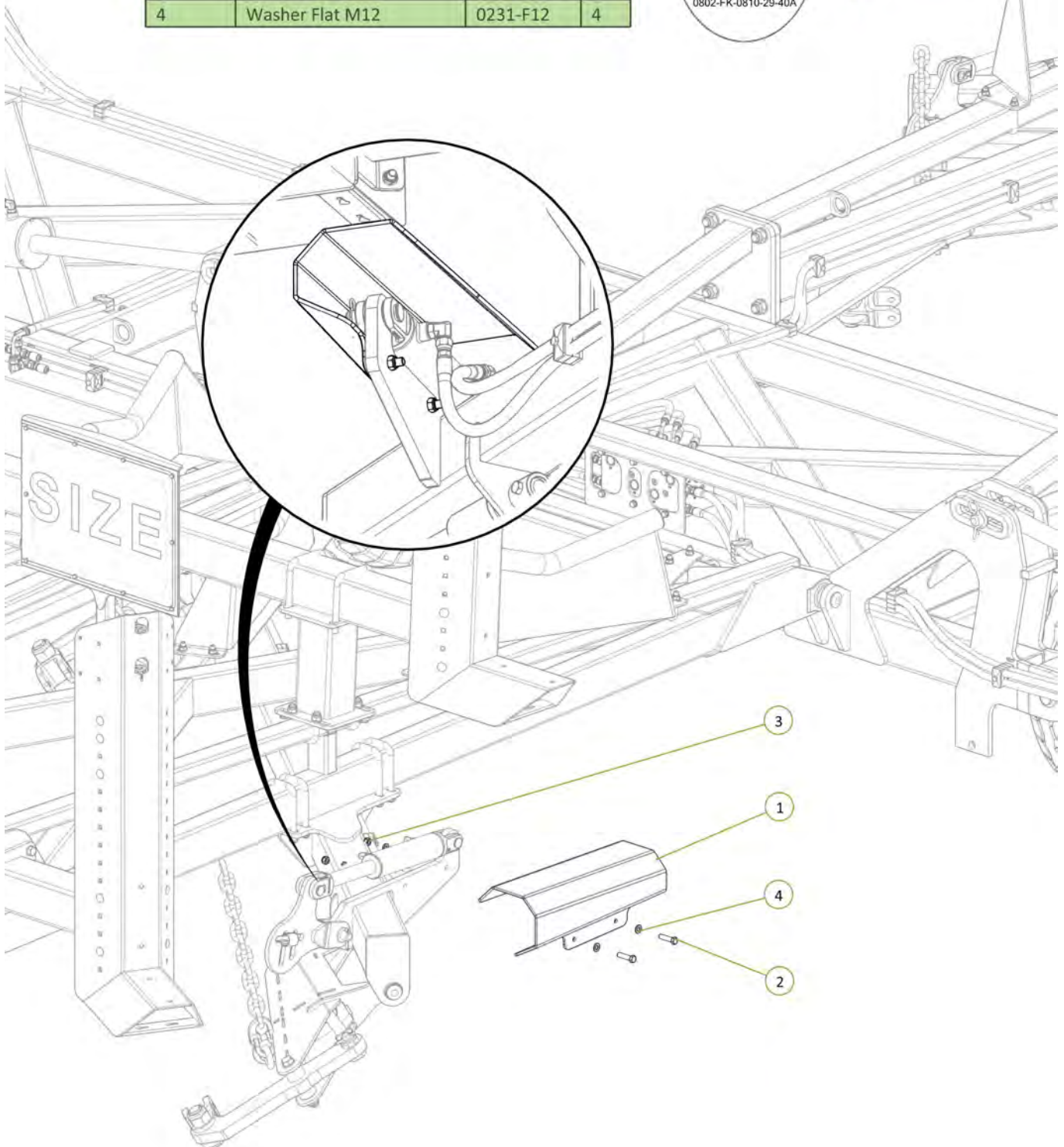

Item No.	Description	Number	Qty
1	Safety Chain Assembly	0810-16	1

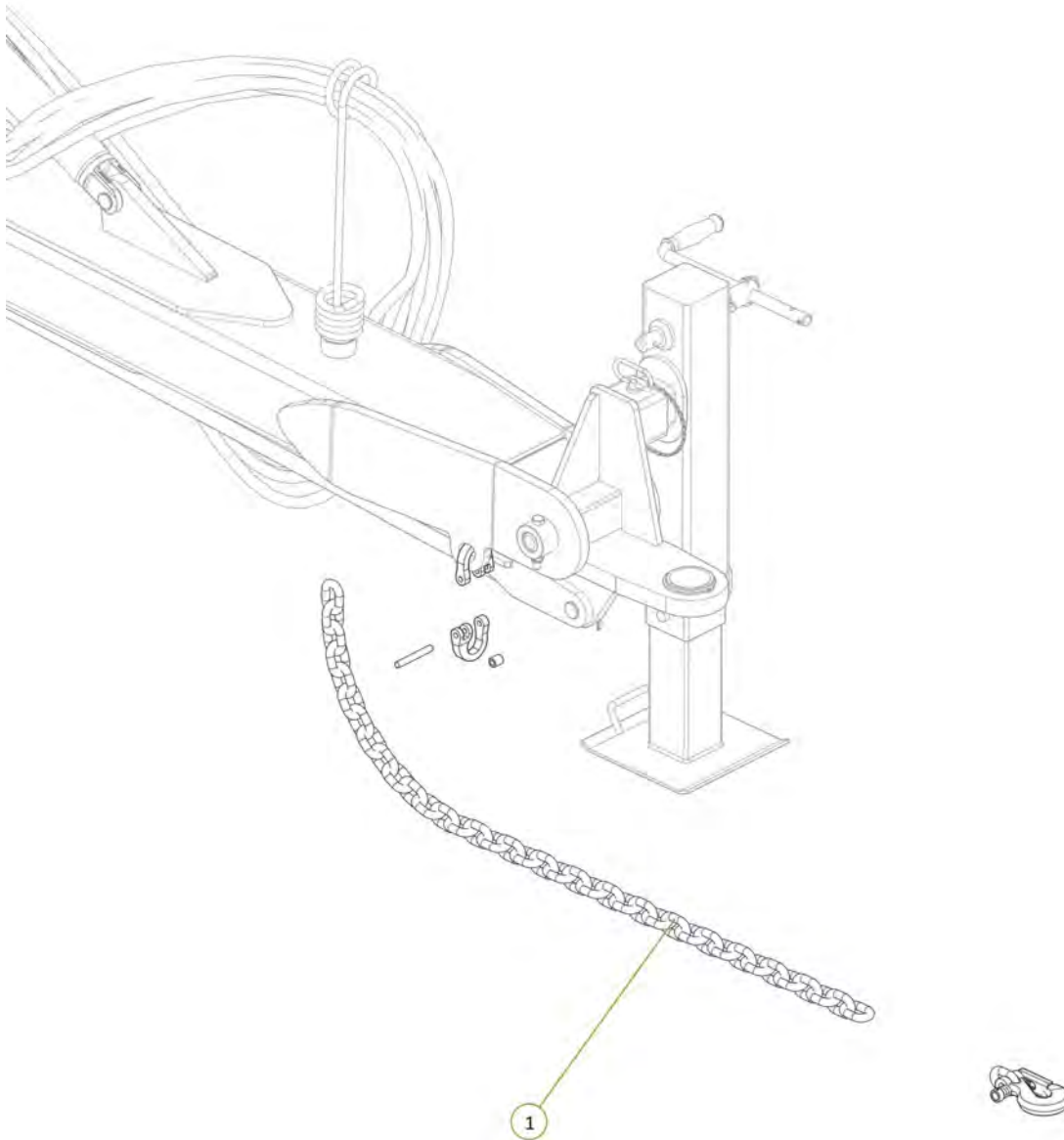

Item No.	Description	Number	Qty
1	Operator Manual Cannister	0801-OMC-1	1
2	Ratcheting Gear Wrench 1 3/4"	0802-GW1 3-4	1
3	20mm Bolt Swivel Unit	0802-PCHB55	1
4	M20 x 110 grade 10.9 ZP Short Thread Bolt	0211-20110ST	1
5	Nyloc Nut M20	0221-NYL20	1
6	M6 x 20 Trilobe self tapping ScREW	0211-M620MZPHTF	3

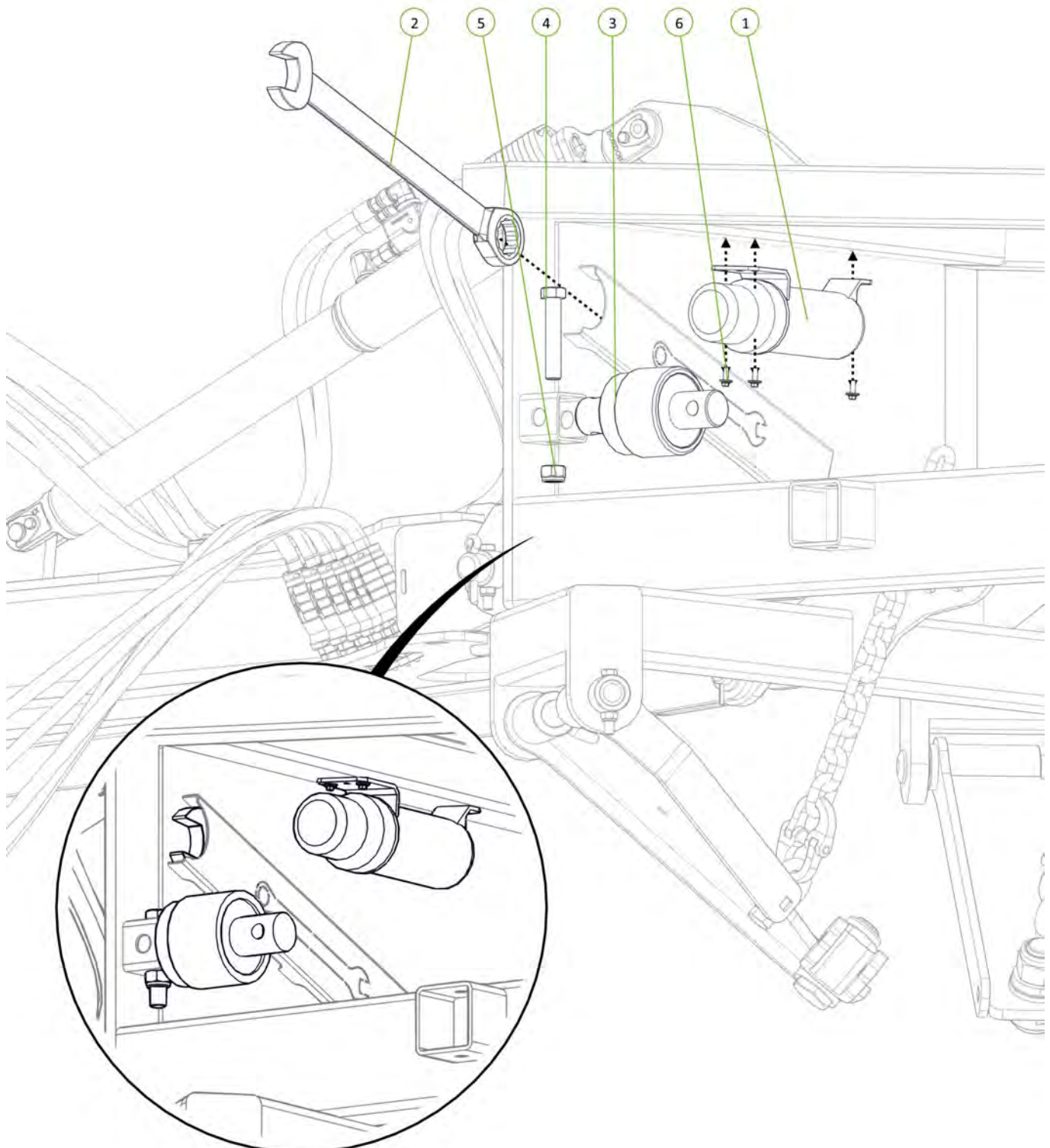

Item No.	Description	Number	Qty
1	Cylinder Safety Stop	0800-688	1
2	Square Loop Pin 5/16" x 3 1/4"	0511-PINLOOPSQ516x314	1

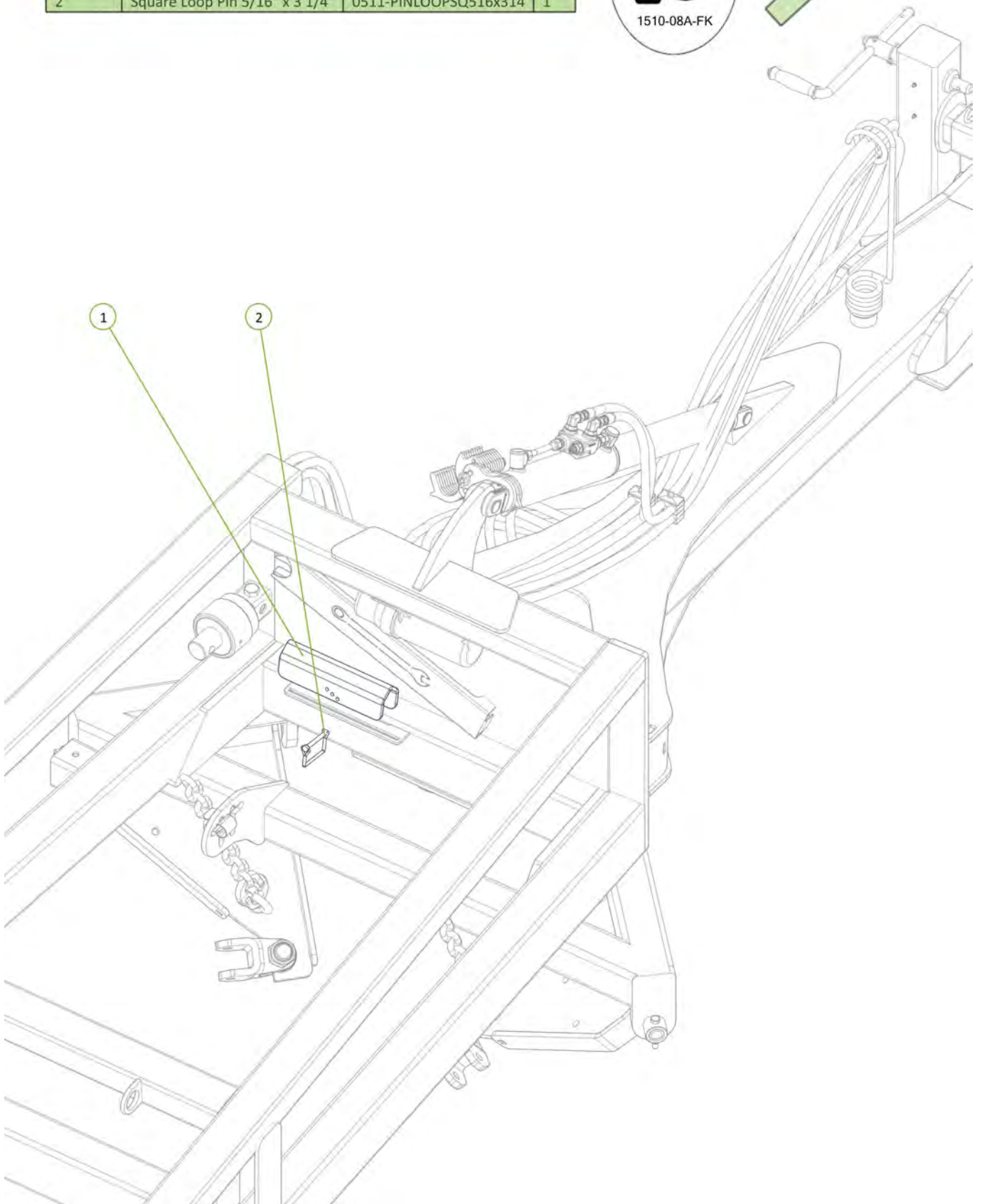

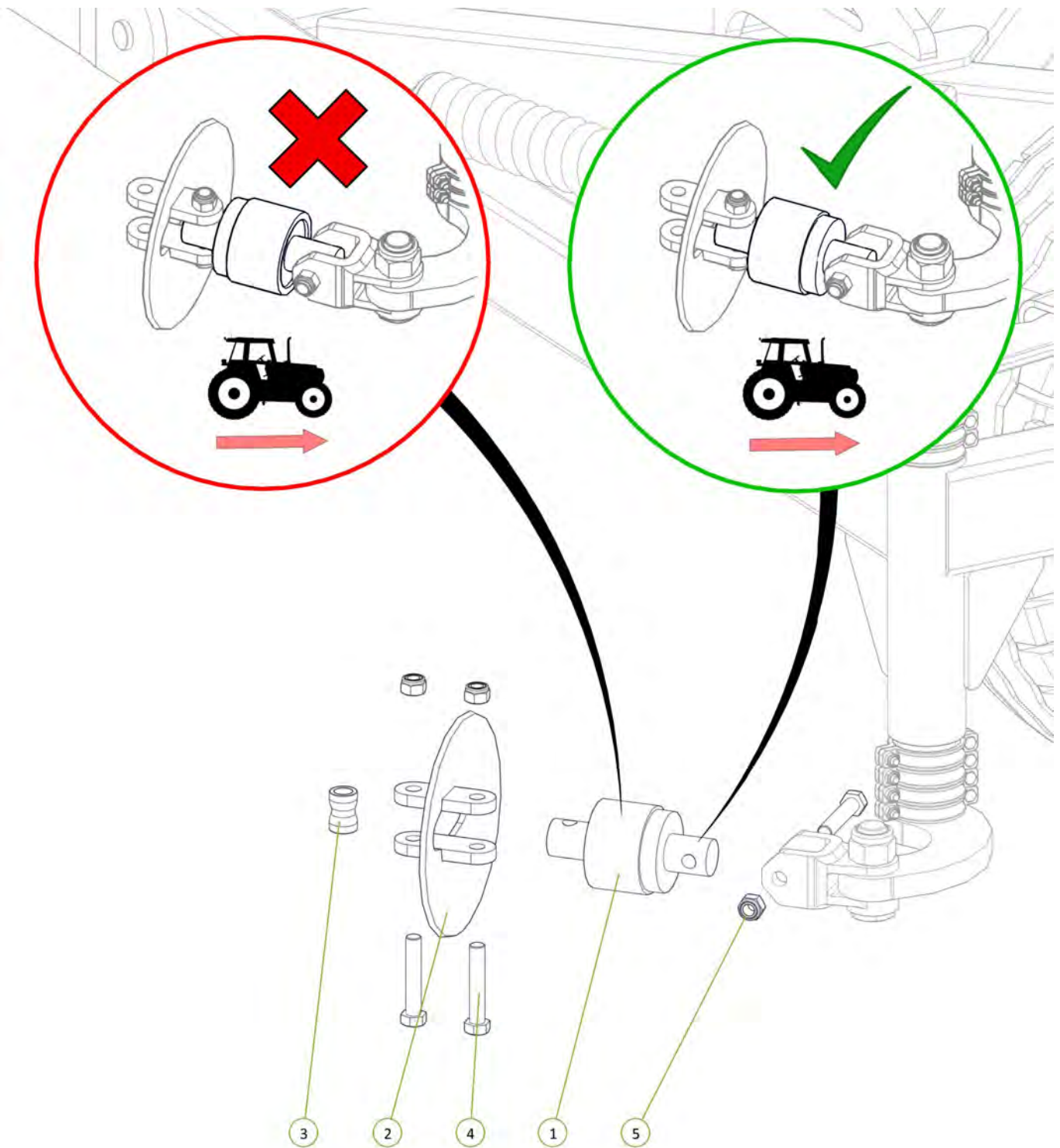

Item No.	Description	Number	Qty
1	20mm Bolt Swivel Unit	0802-PCHB55	1
2	Disc Chain Tie Plate Link 20mm	0802-DCTP-20	1
3	Disc Chain Spacer	0801-253755	1
4	M20 x 110 grade 10.9 ZP Short Thread Bolt	0211-20110ST	3
5	Nyloc Nut M20	0221-NYL20	3



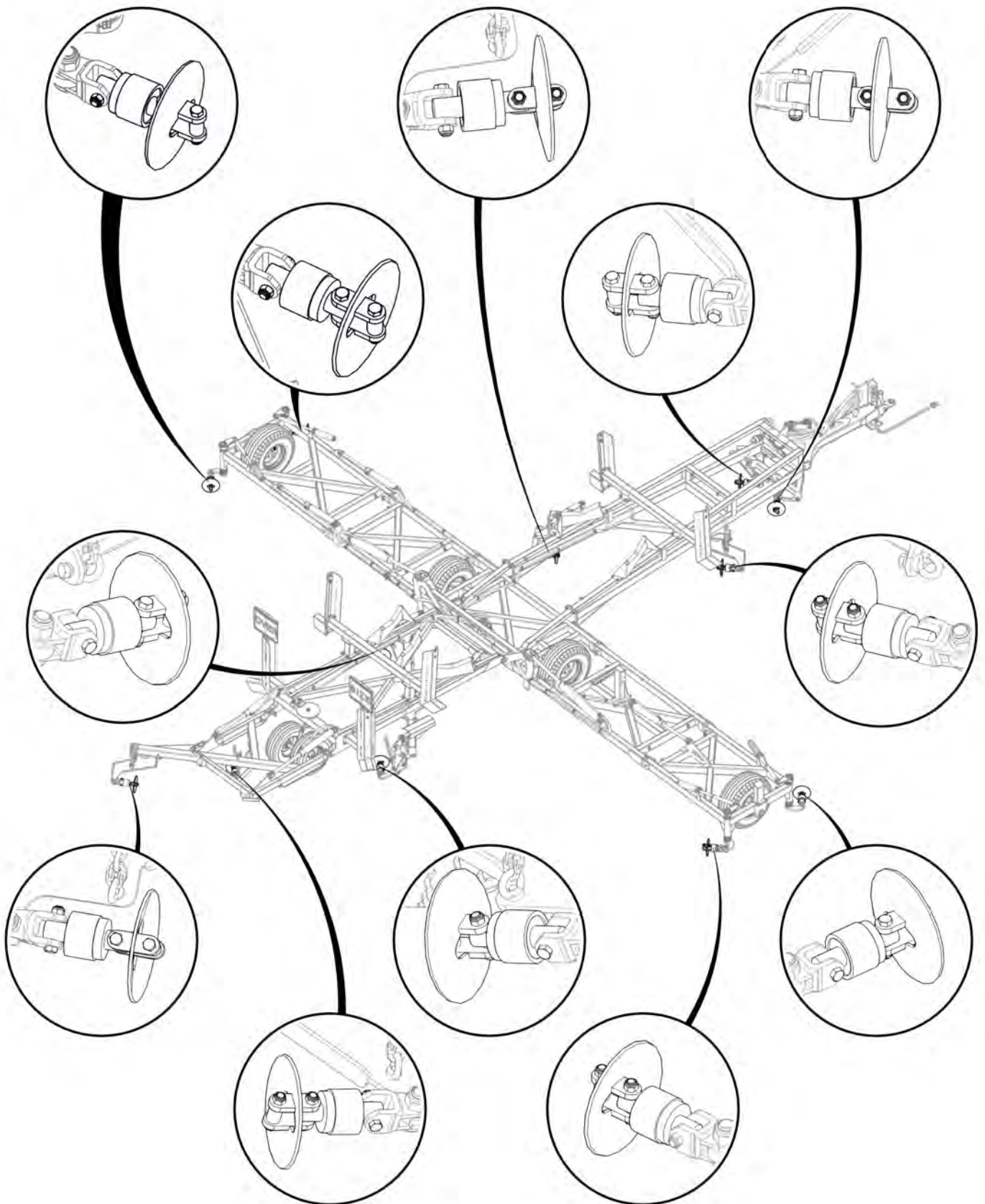

Ensure bearings are correctly orientated with seals facing the rear of the machine

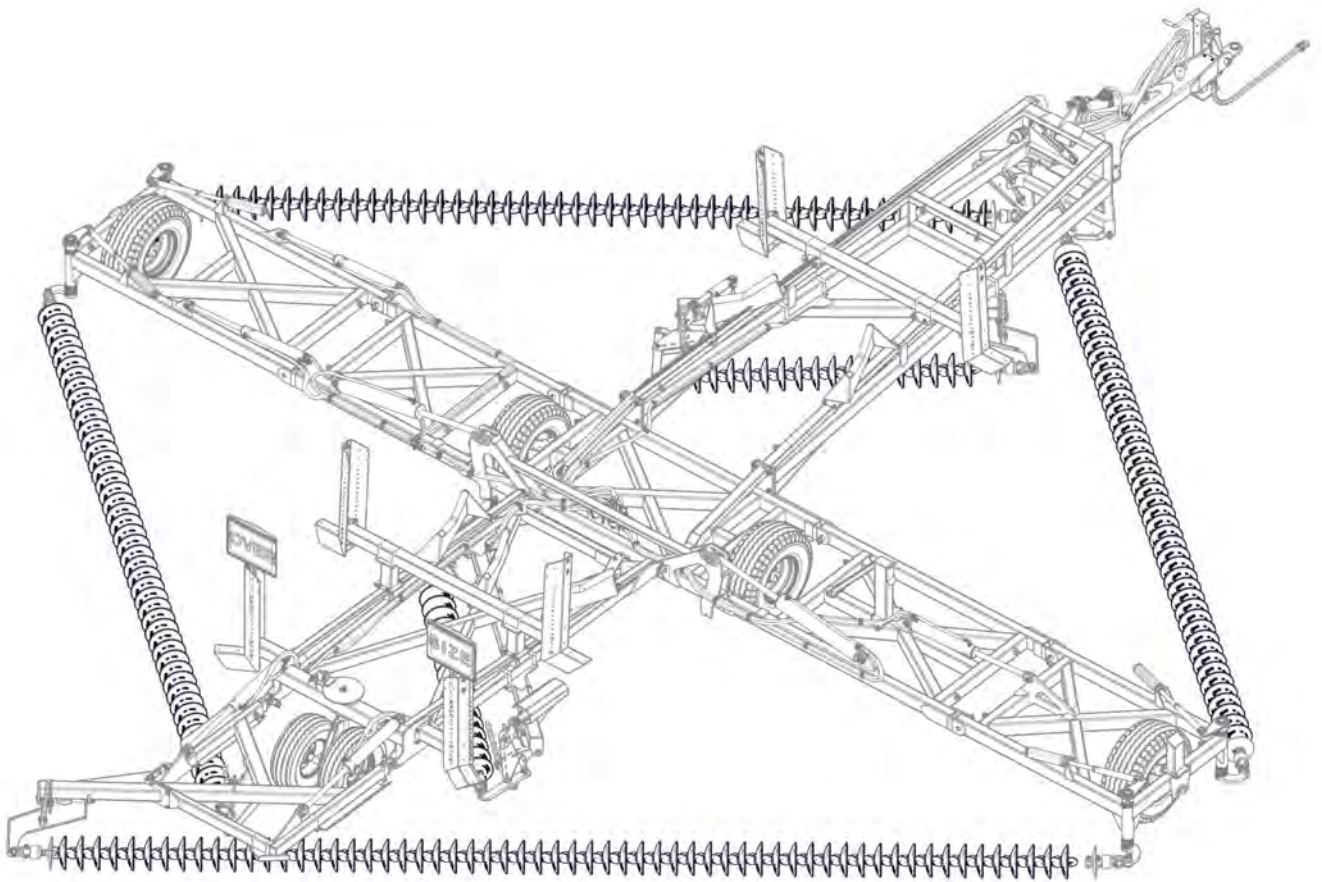



Section 3 - Decal Placement

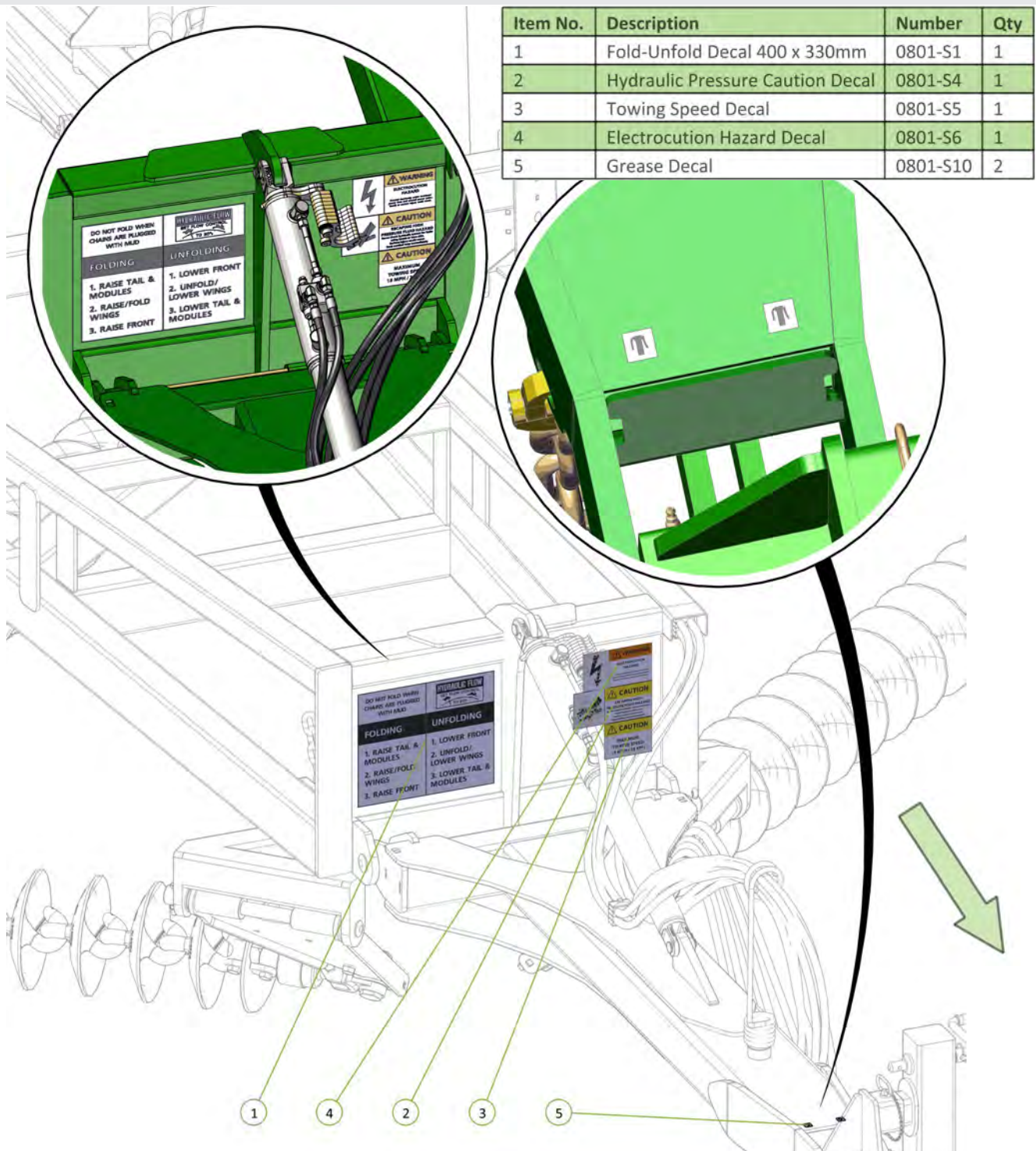

Item No.	Description	Number	Qty
1	Kelly Tillage Data Plate	0801-SKTDP	1

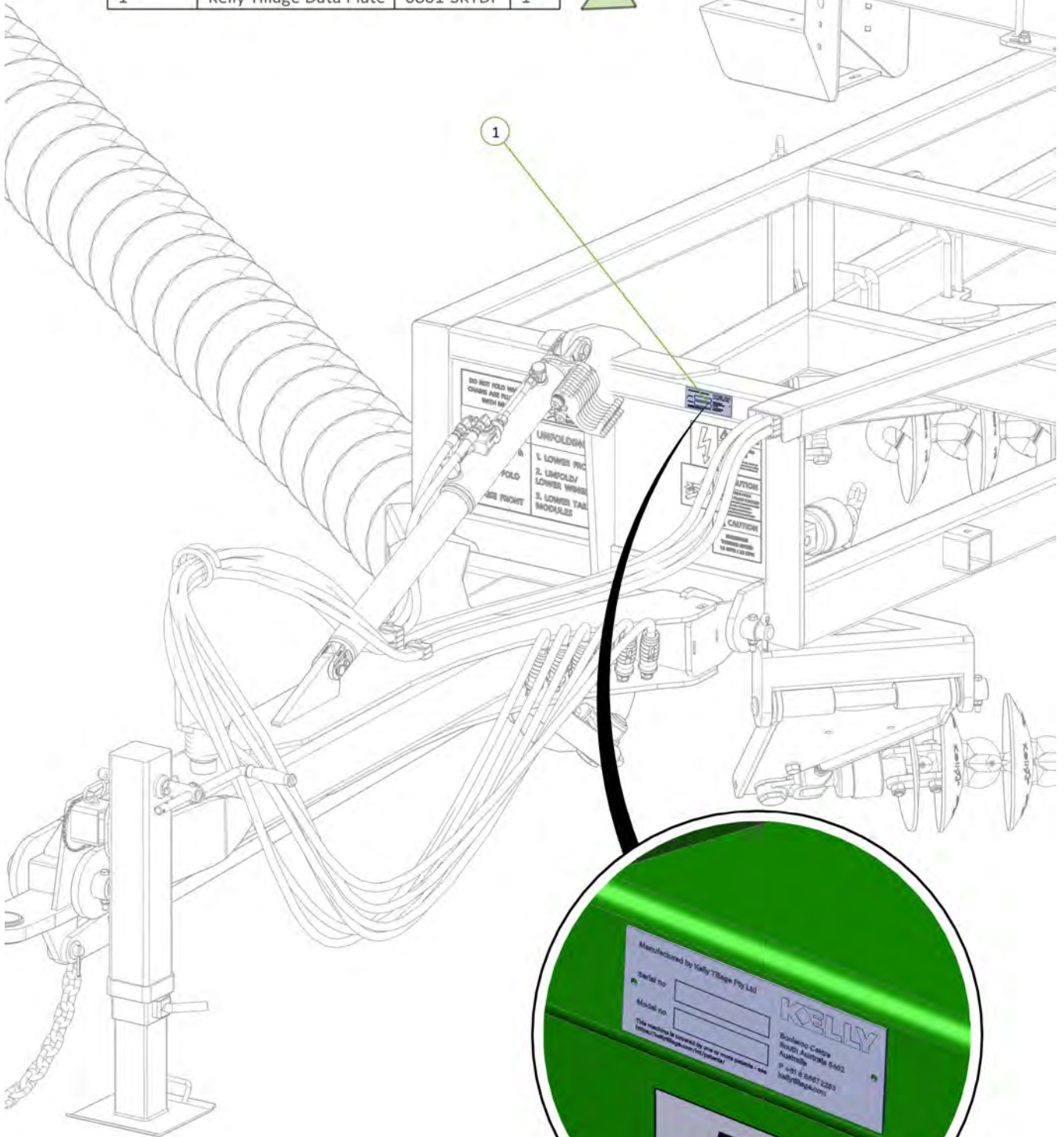

Item No.	Description	Number	Qty
1	Kelly Tillage Decal	0801-S24	2
2	Universal Patent Decal	0801-S26	1

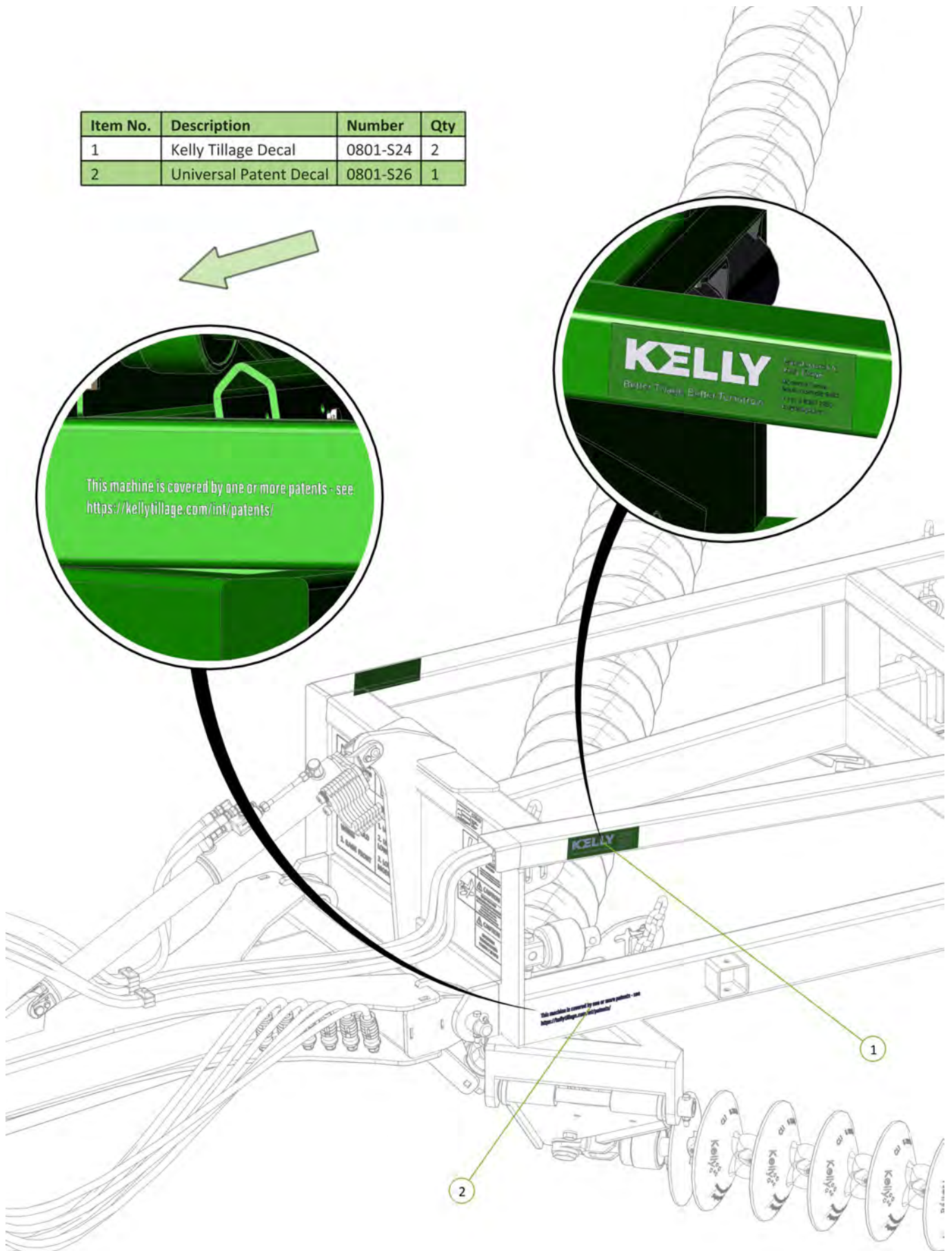

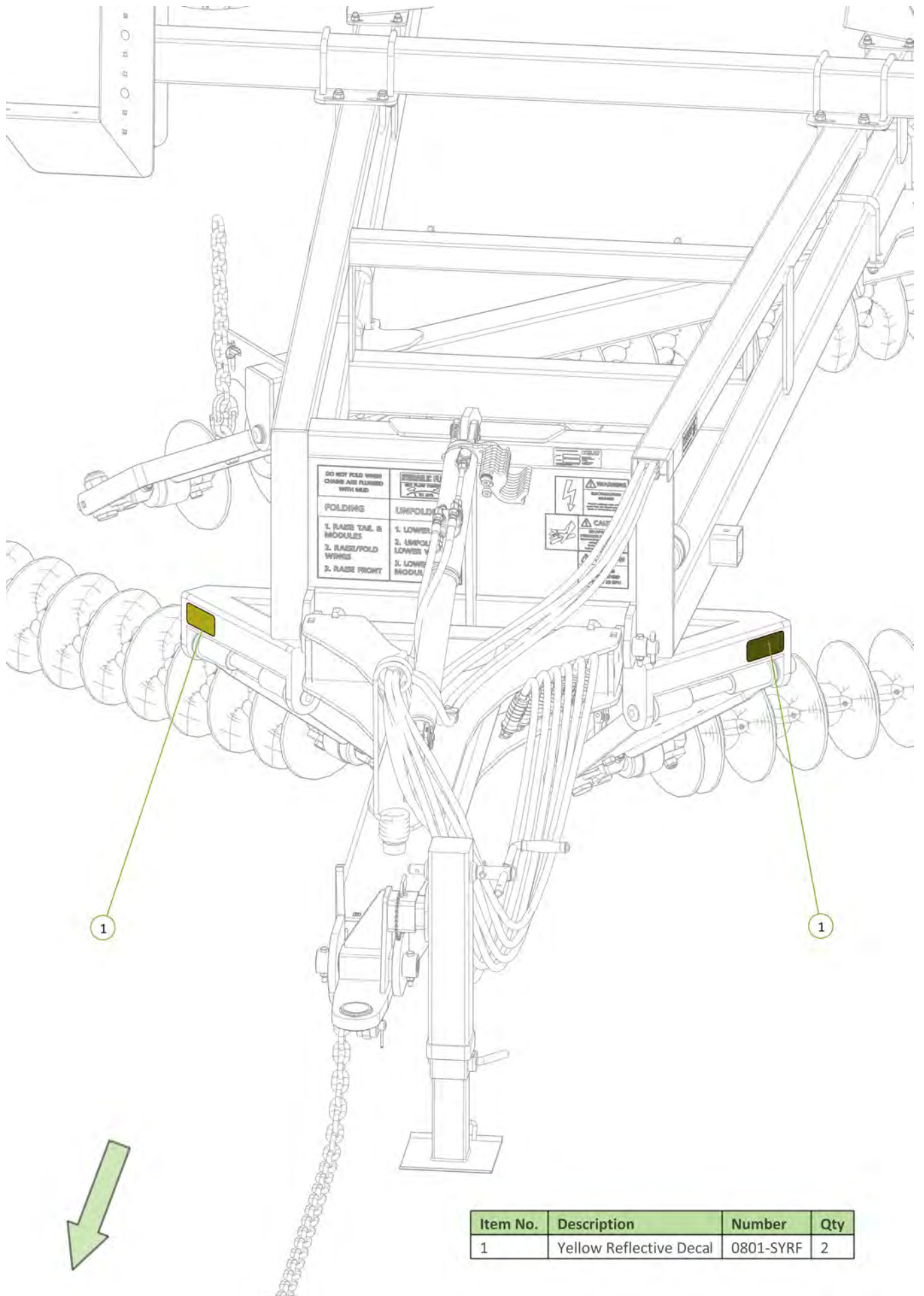

Item No.	Description	Number	Qty
1	Yellow Reflective Decal	0801-SYRF	2

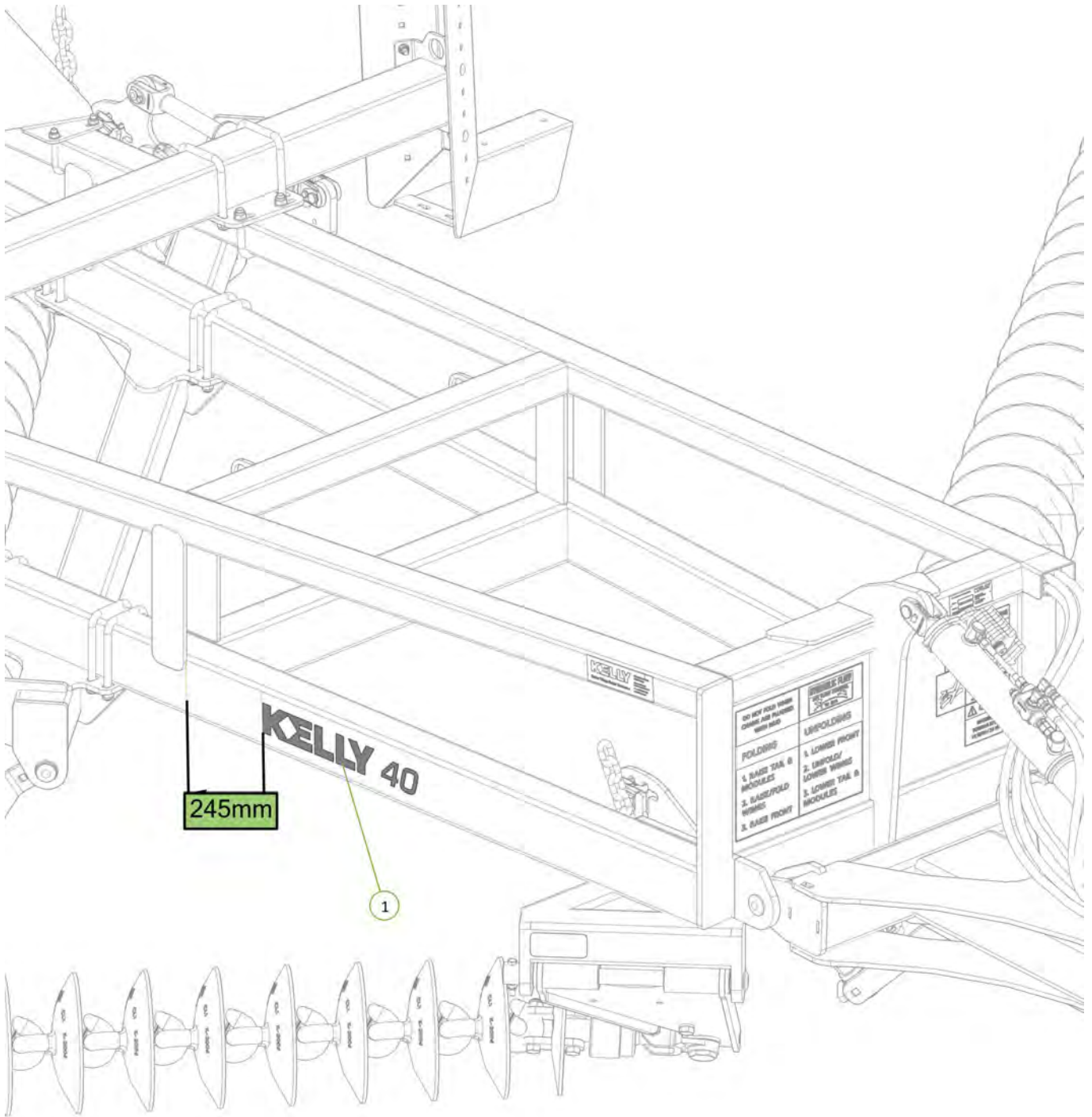

Item No.	Description	Number	Qty
1	Kelly Tillage 40 Decal	0801-SKT40	1



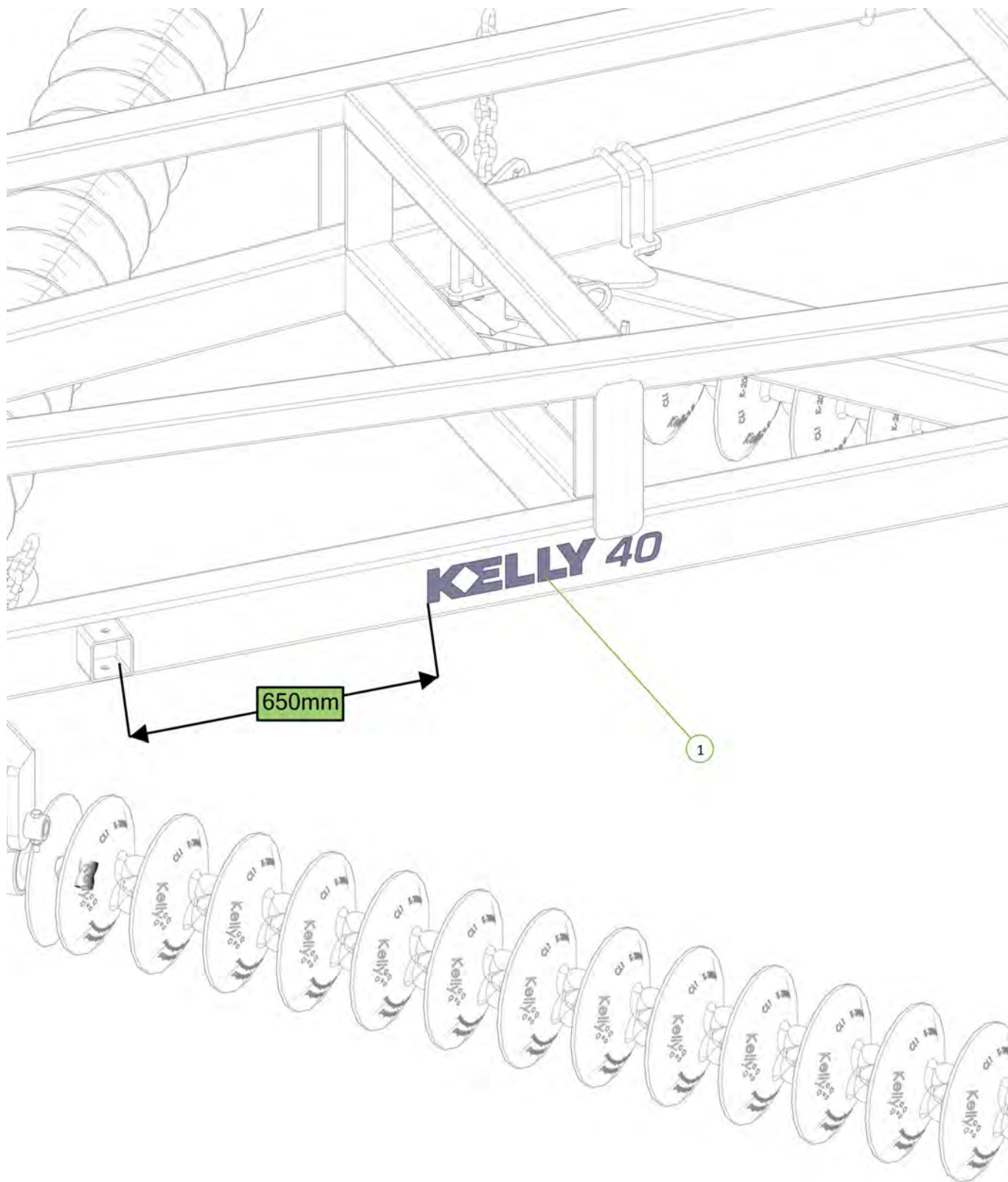

Item No.	Description	Number	Qty
1	Kelly Tillage 40 Decal	0801-SKT40	1



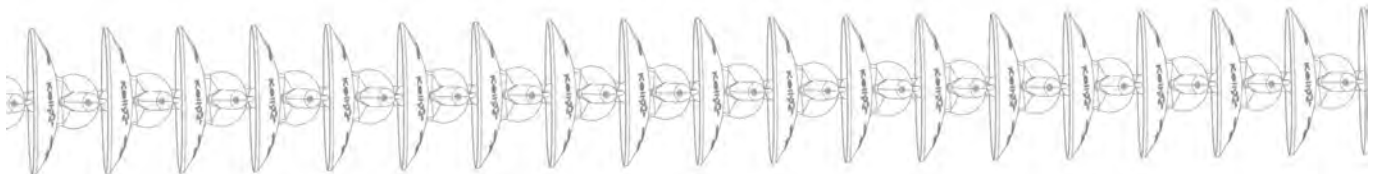
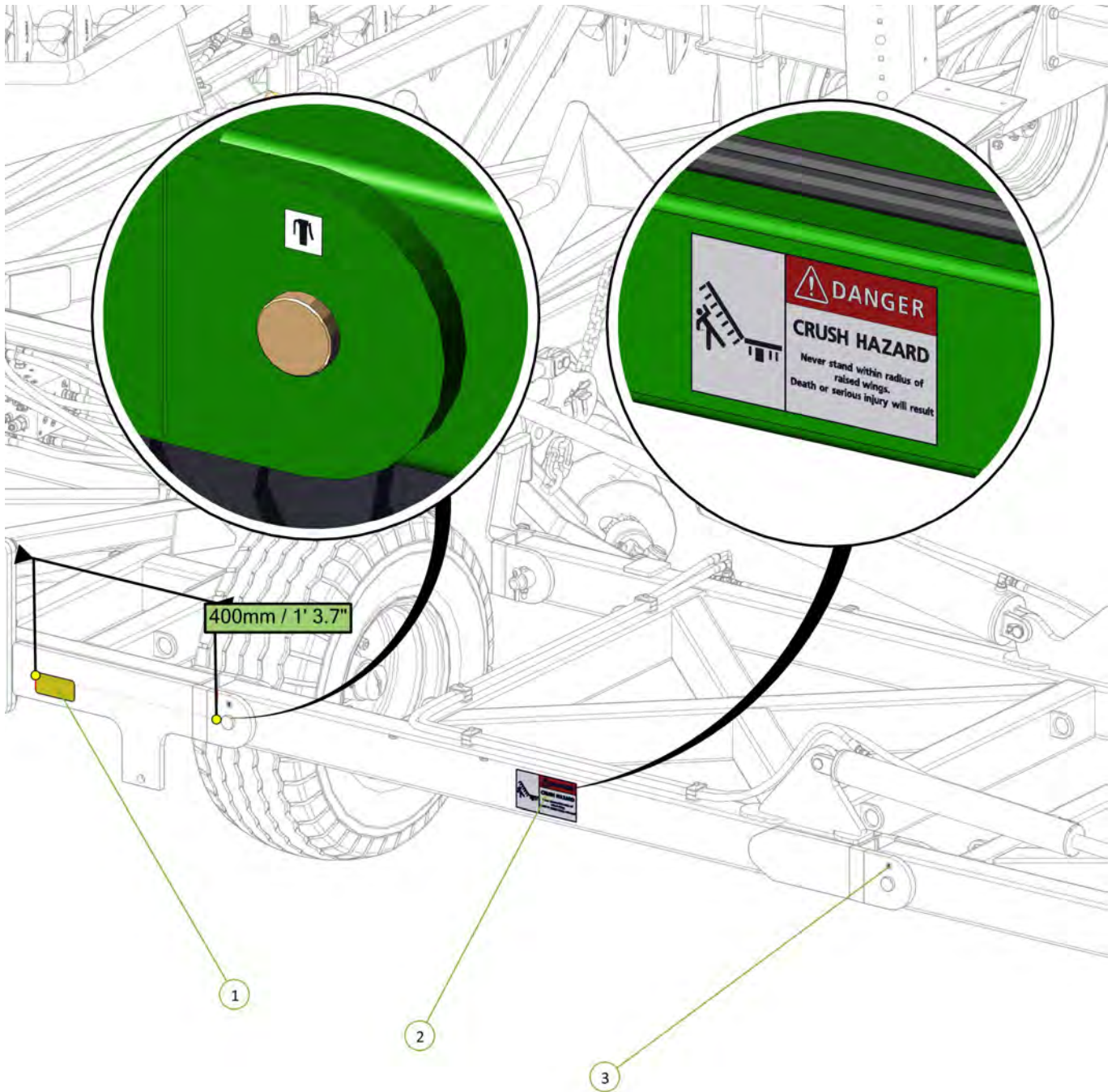

Item No.	Description	Number	Qty
1	Yellow Reflective Decal	0801-SYRF	1
2	Danger Crush Hazard Decal	0801-S3	1
3	Grease Decal	0801-S10	2



Item No.	Description	Number	Qty
1	Yellow Reflective Decal	0801-SYRF	1

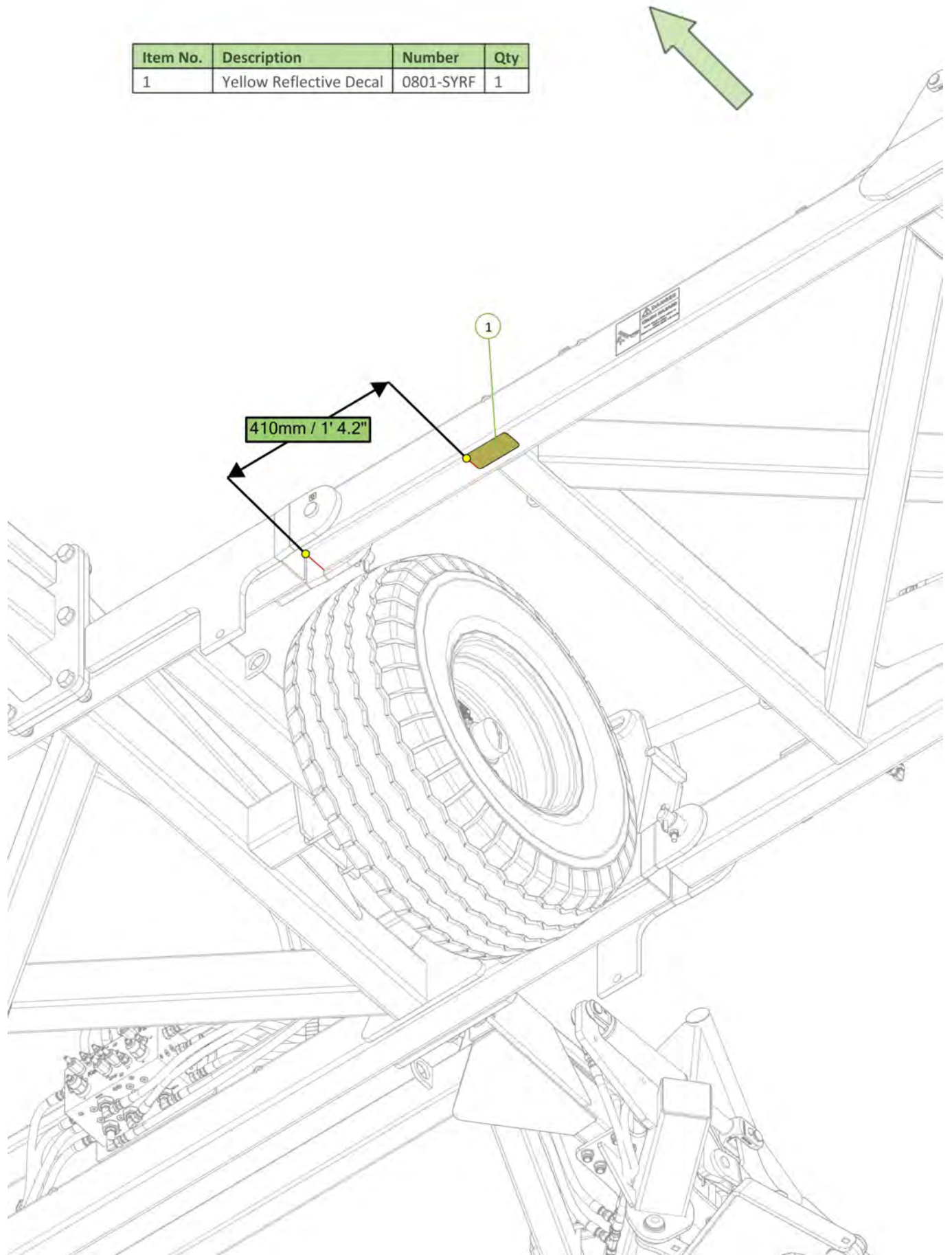

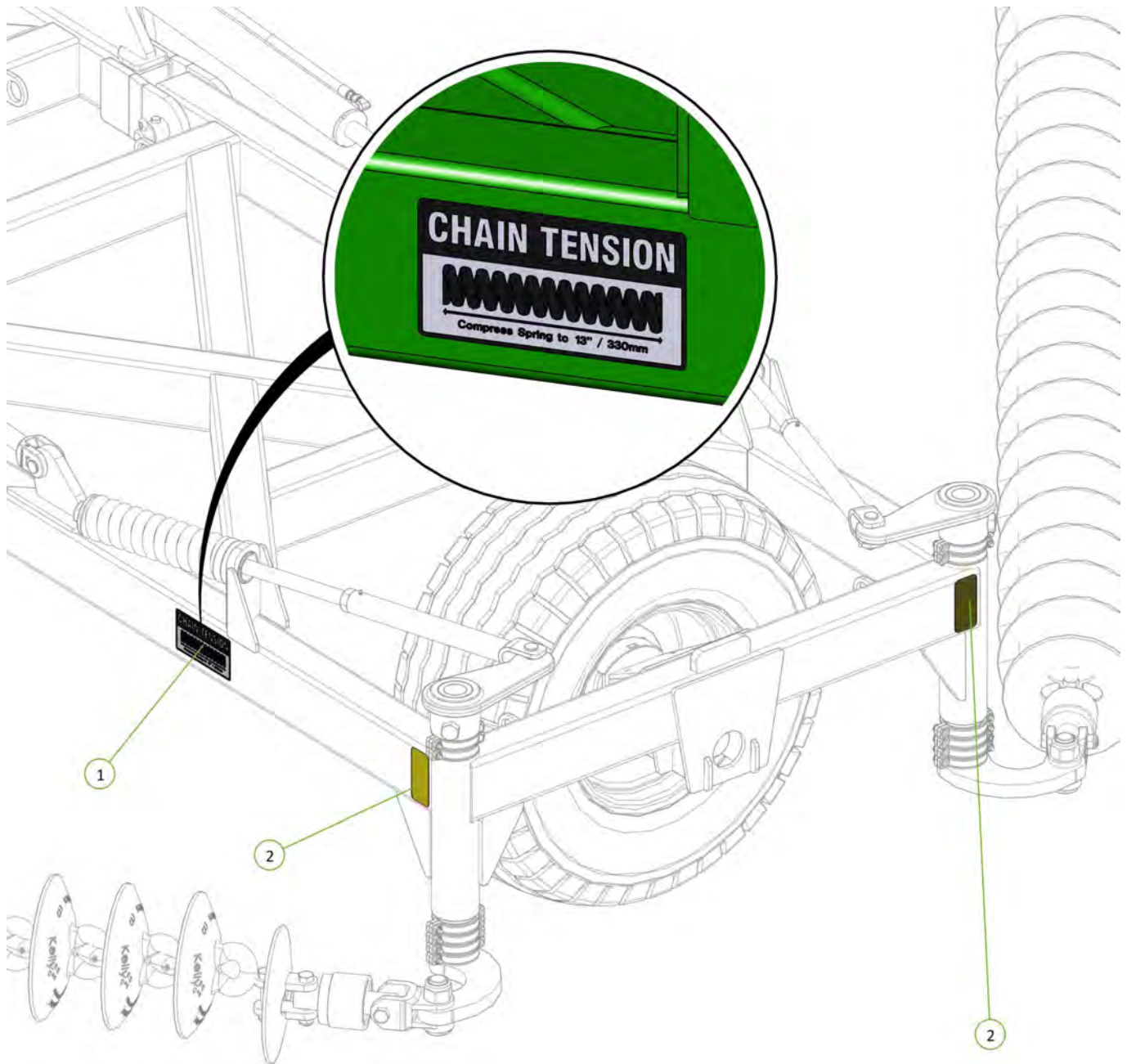

Item No.	Description	Number	Qty
1	Chain Tension 330mm Decal	0801-S15	1
2	Yellow Reflective Decal	0801-SYRF	2



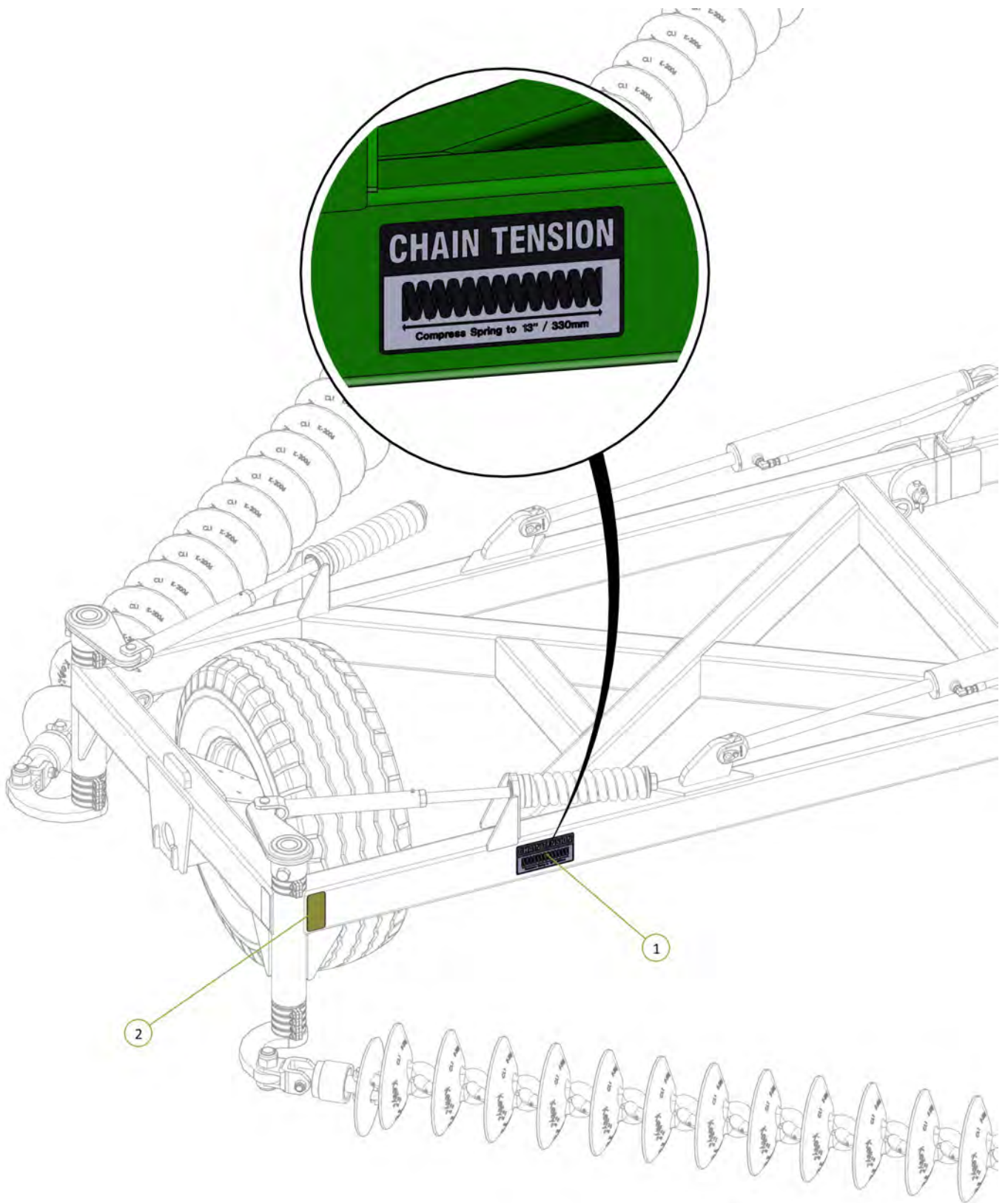

Item No.	Description	Number	Qty
1	Chain Tension 330mm Decal	0801-S15	1
2	Red Reflective Decal	0801-SRRF	1



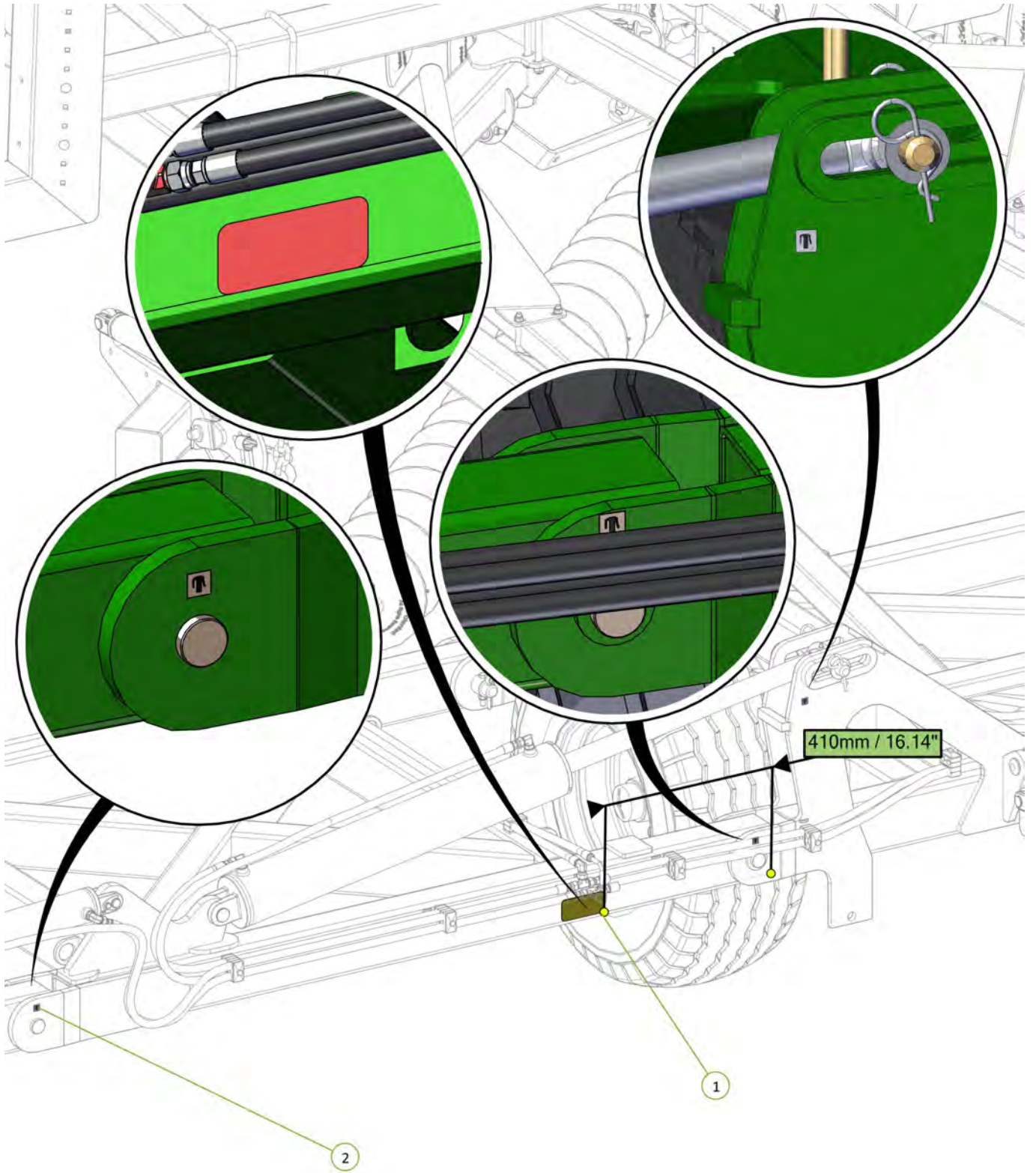

Item No.	Description	Number	Qty
1	Red Reflective Decal	0801-SRRF	1
2	Grease Decal	0801-S10	3



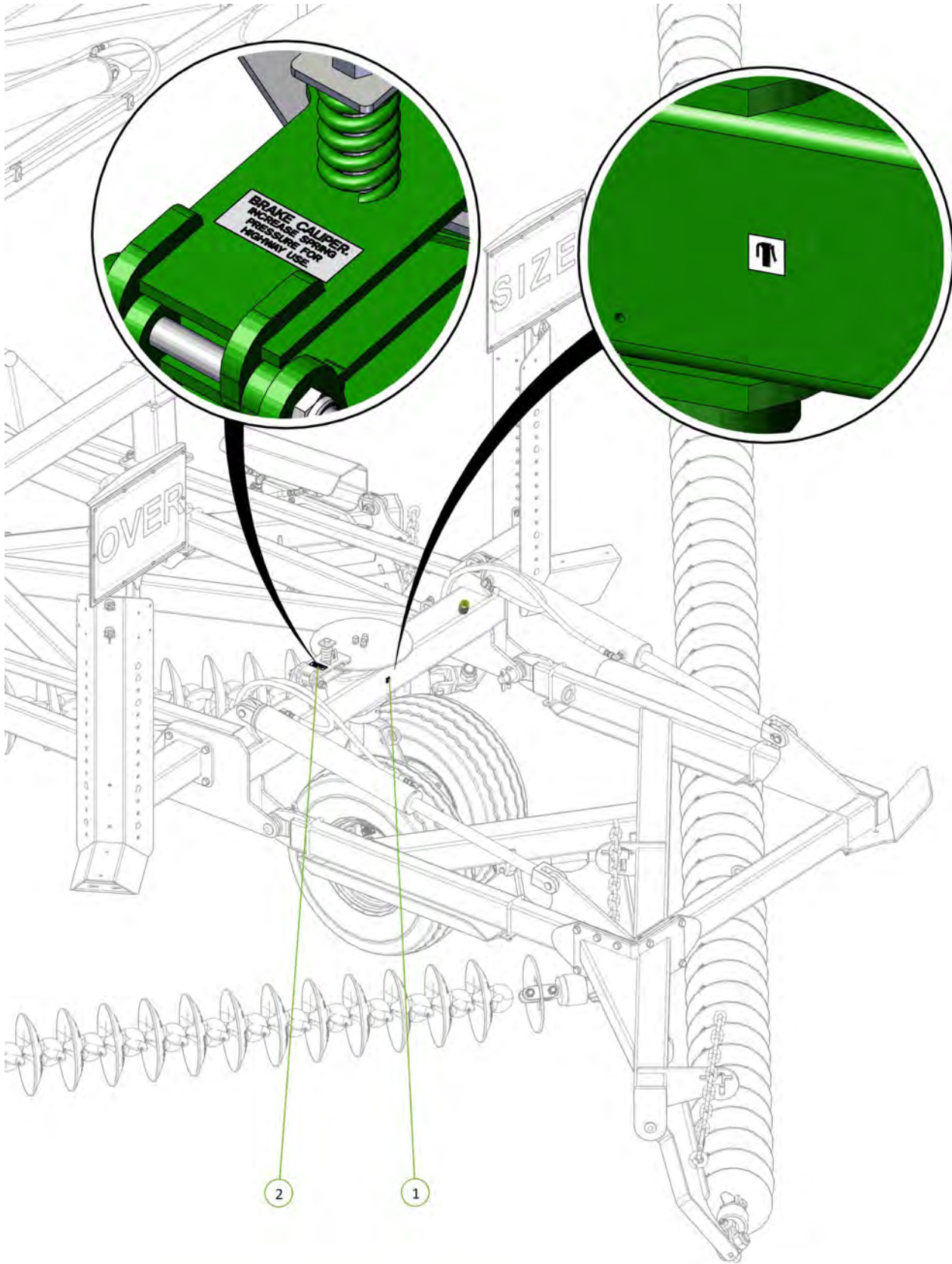

Item No.	Description	Number	Qty
1	Grease Decal	0801-S10	1
2	Brake Caliper Decal	0801-S11	1

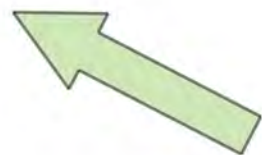

Item No.	Description	Number	Qty
1	Yellow Reflective Decal	0801-SYRF	1

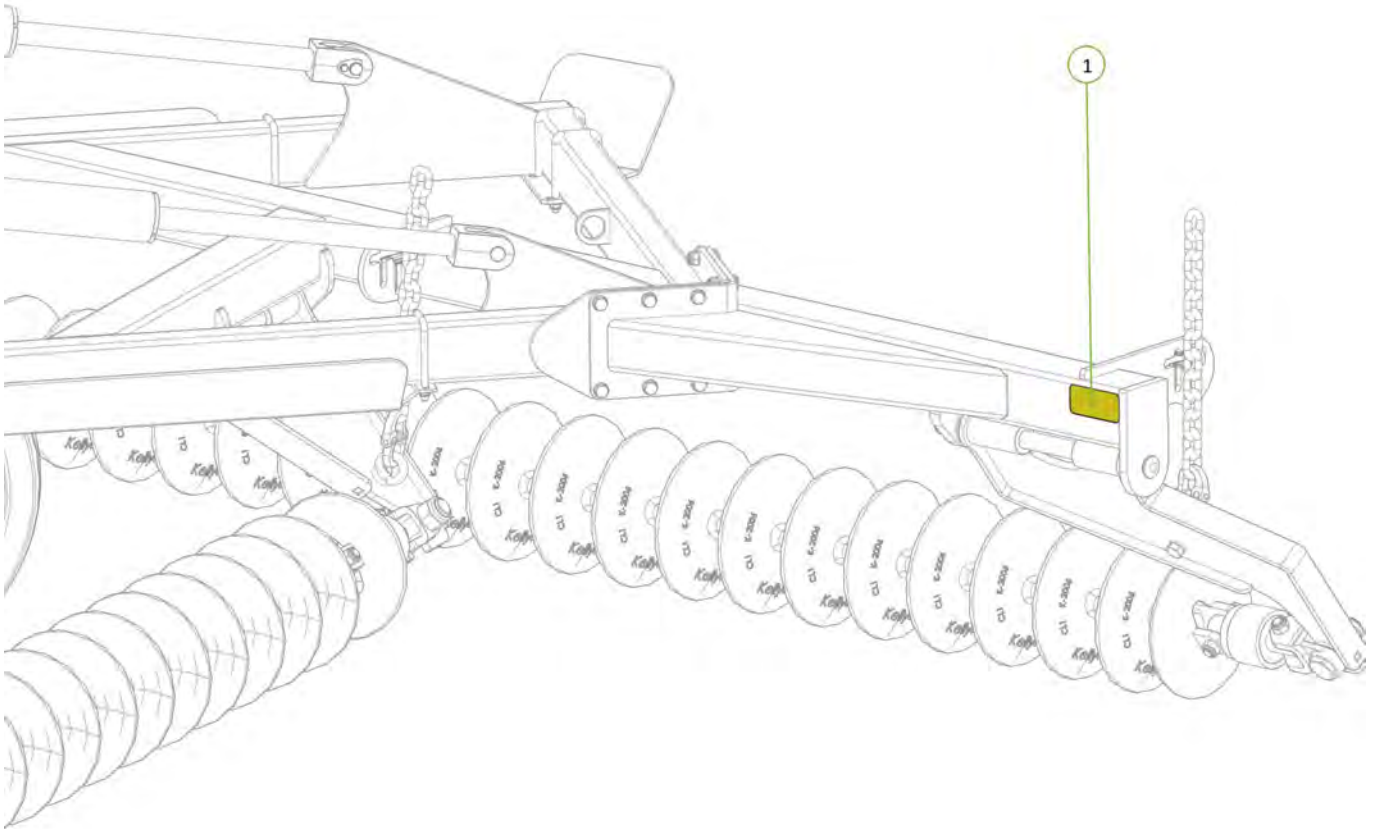

Item No.	Description	Number	Qty
1	Yellow Reflective Decal	0801-SYRF	1

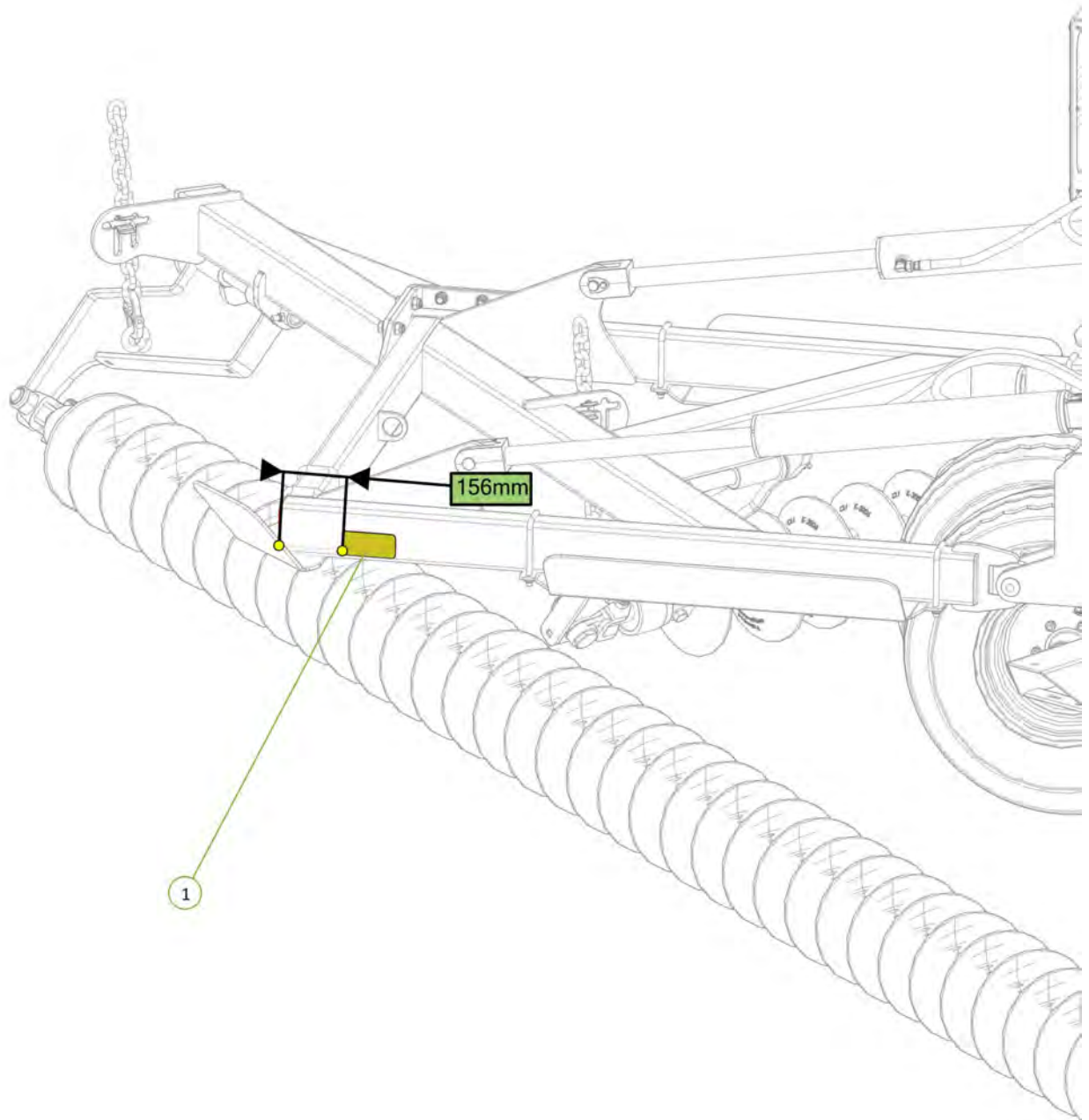

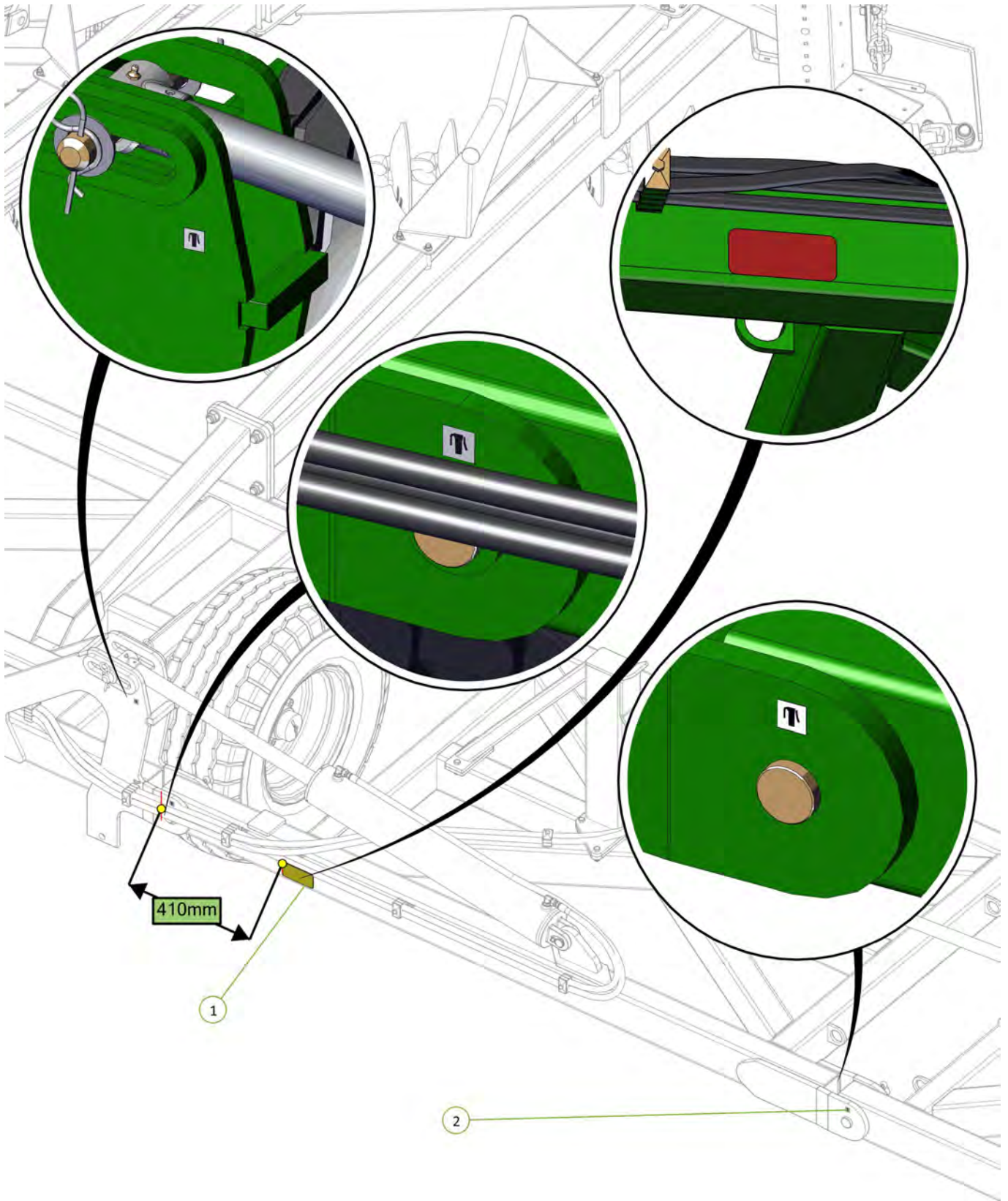

Item No.	Description	Number	Qty
1	Red Reflective Decal	0801-SRRF	1
2	Grease Decal	0801-S10	3



Item No.	Description	Number	Qty
1	Chain Tension 330mm Decal	0801-S15	1
2	Red Reflective Decal	0801-SRRF	1
3	Yellow Reflective Decal	0801-SYRF	1

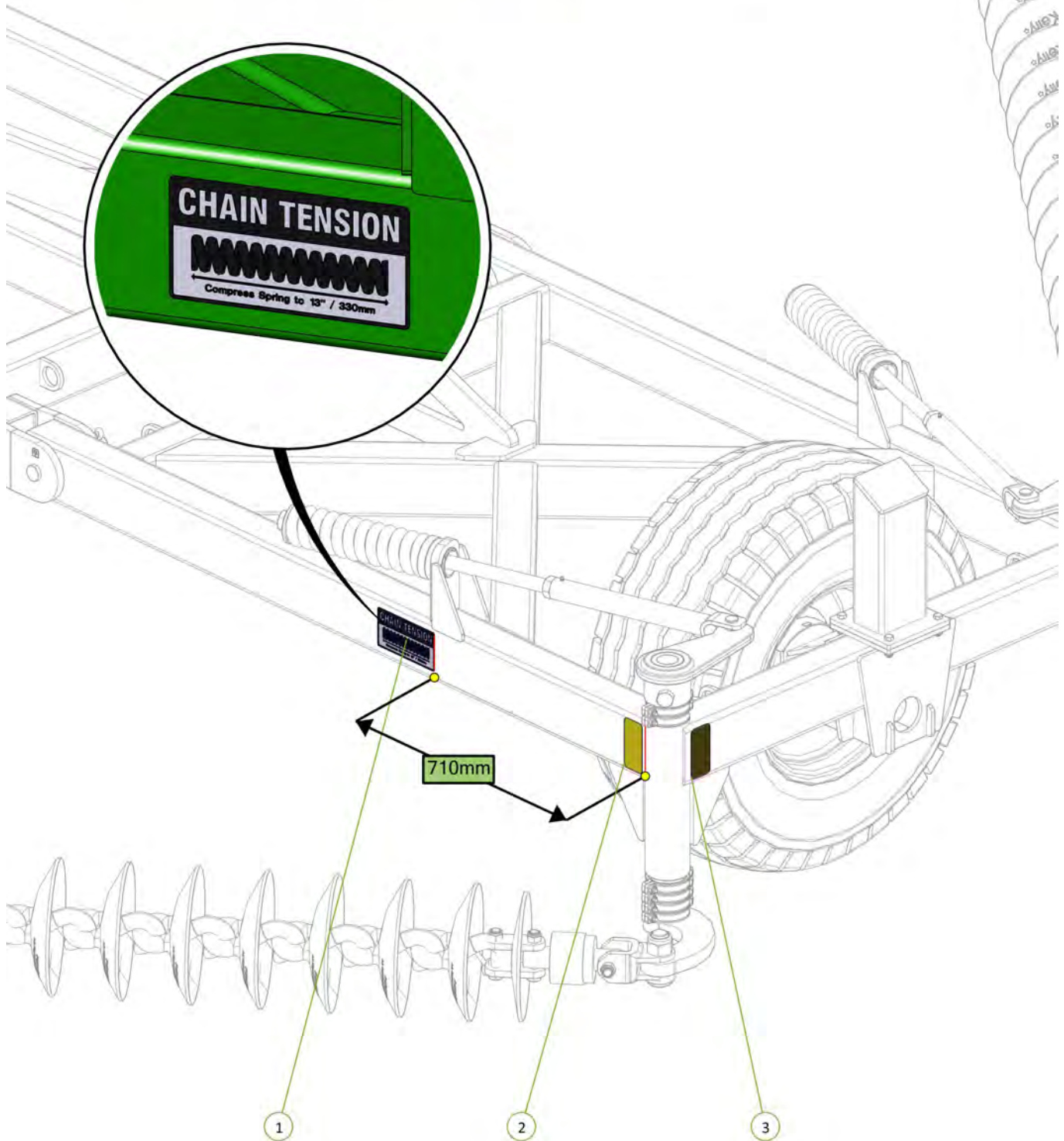
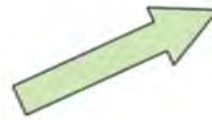

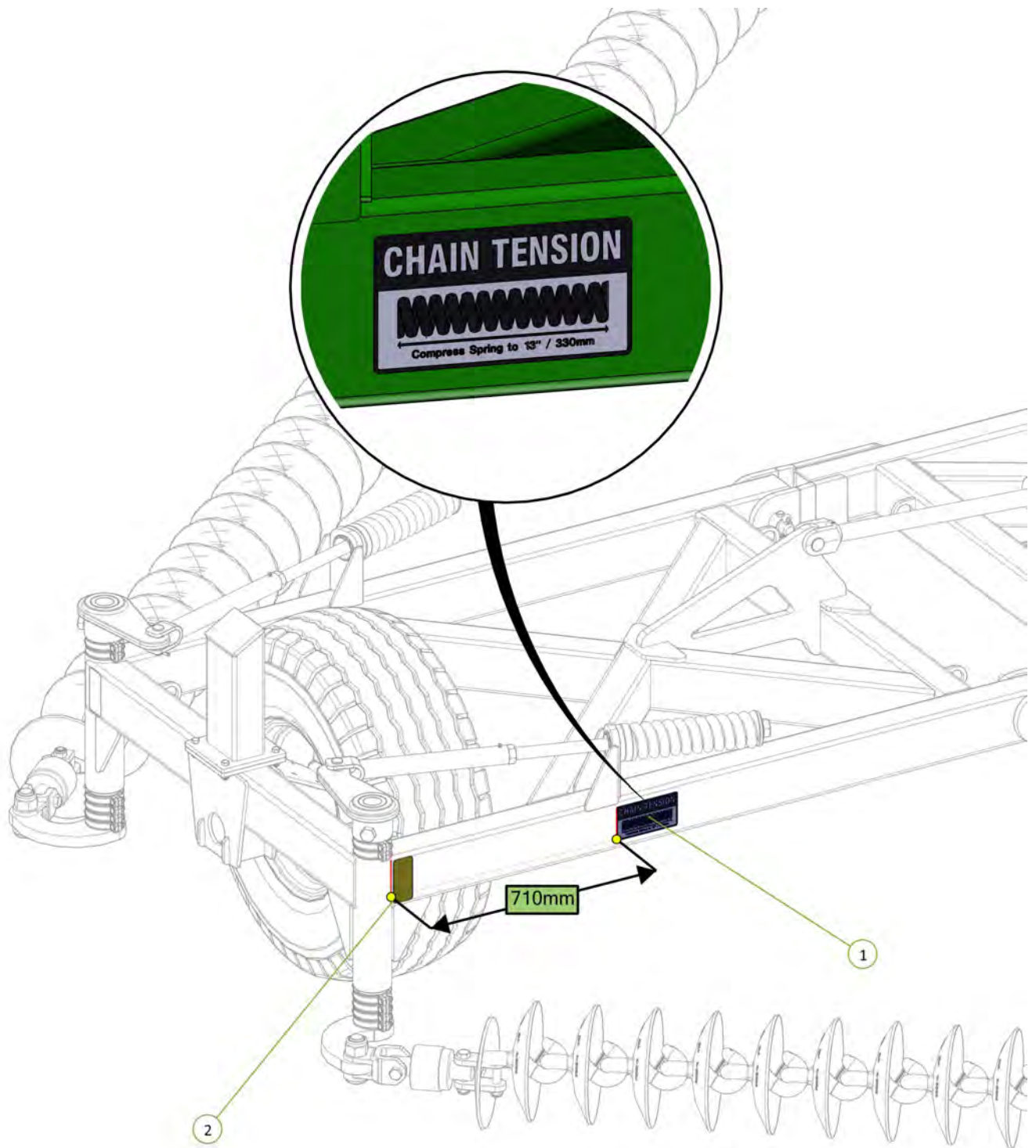

Item No.	Description	Number	Qty
1	Chain Tension 330mm Decal	0801-S15	1
2	Yellow Reflective Decal	0801-SYRF	1



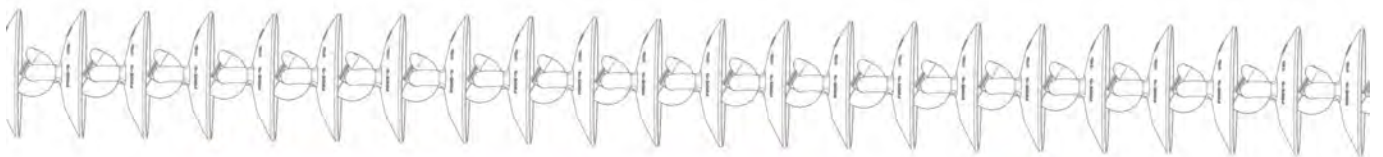
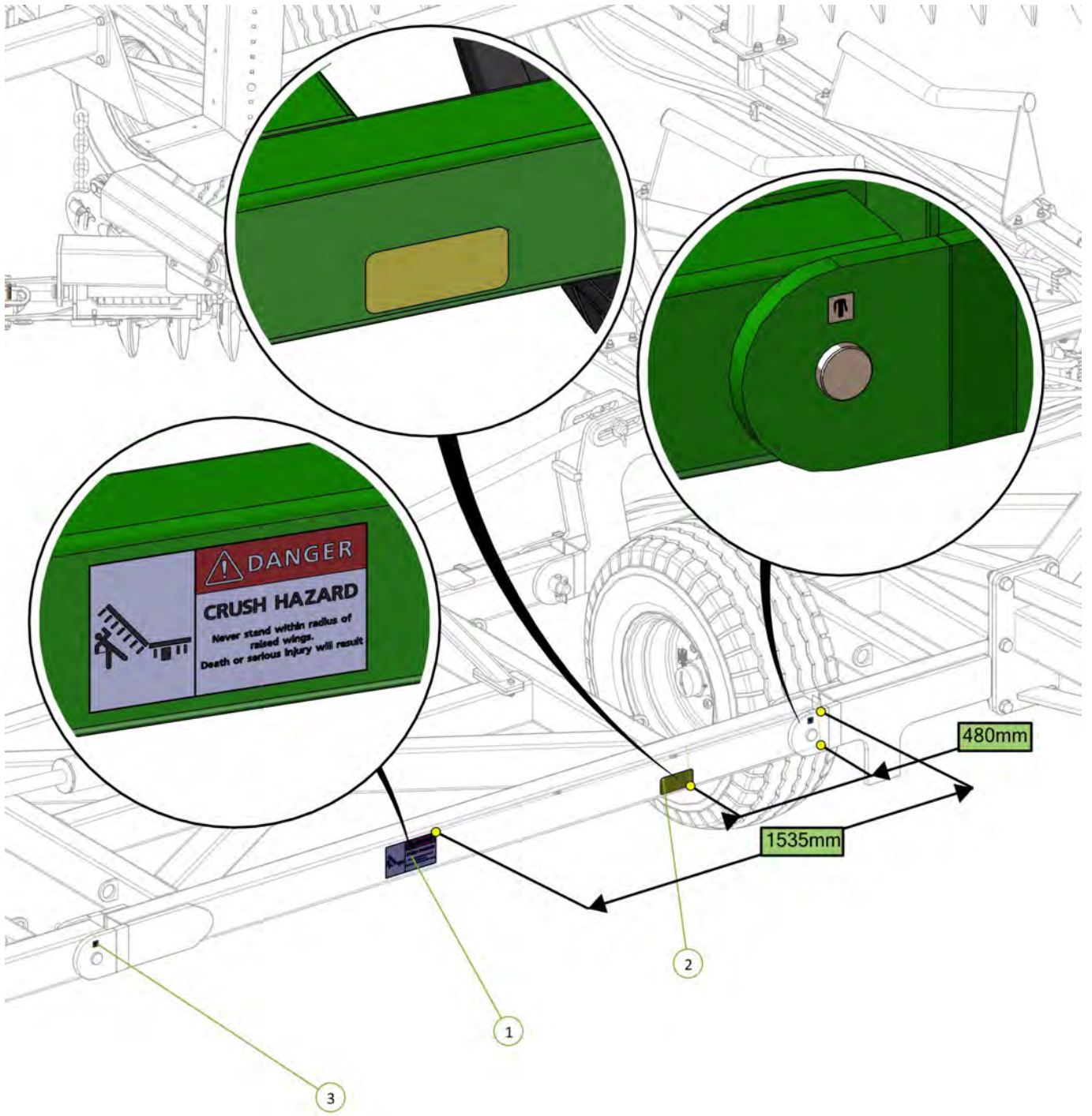

Item No.	Description	Number	Qty
1	Danger Crush Hazard Decal	0801-S3	1
2	Yellow Reflective Decal	0801-SYRF	1
3	Grease Decal	0801-S10	2



Item No.	Description	Number	Qty
1	Yellow Reflective Decal	0801-SYRF	1

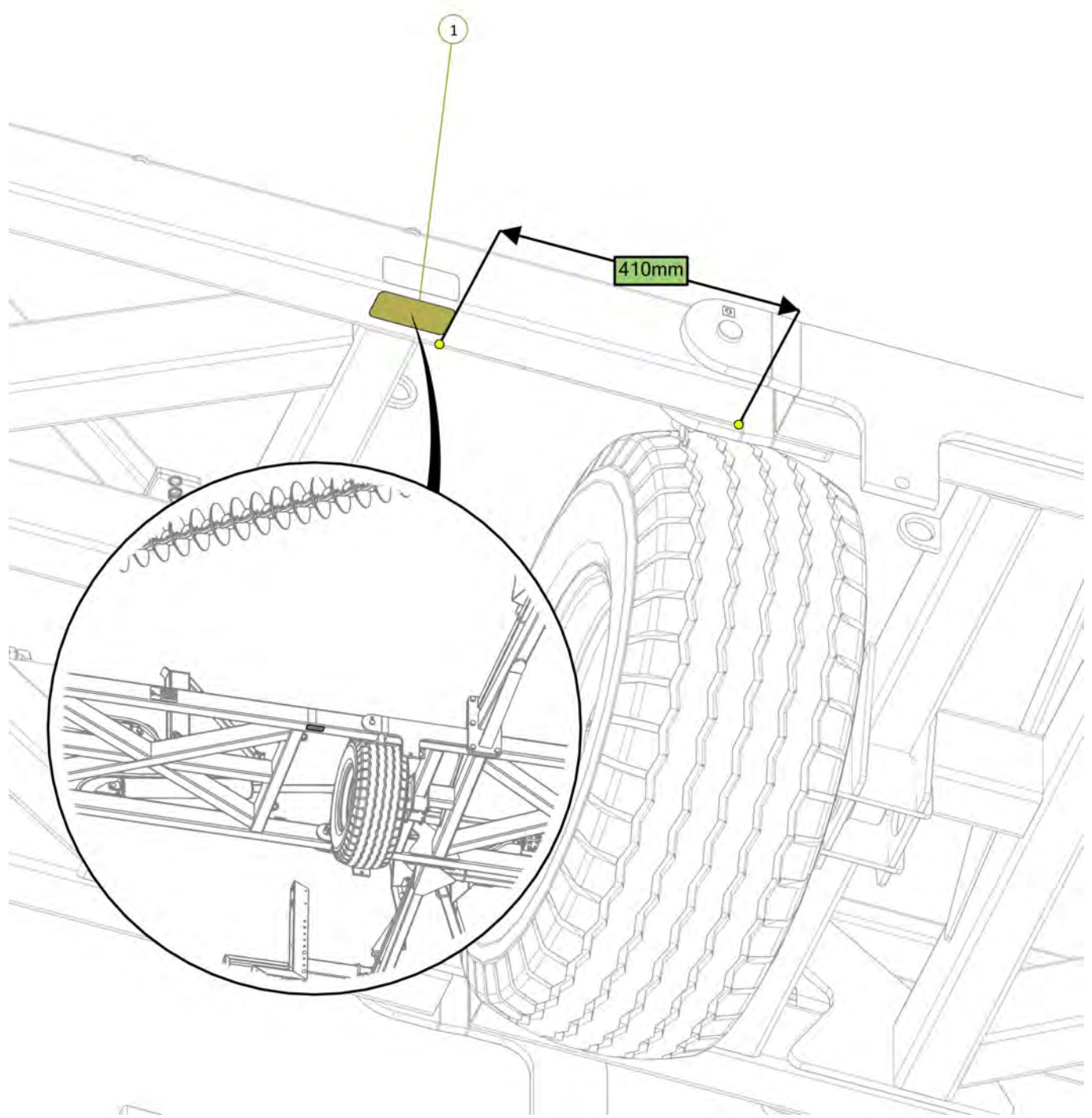

Item No.	Description	Number	Qty
1	Wheel Nut Decal	0801-S9	4
2	Decal- 15.0/70/18 Tyre Inflation	0801-S8-15.5-70-18	4

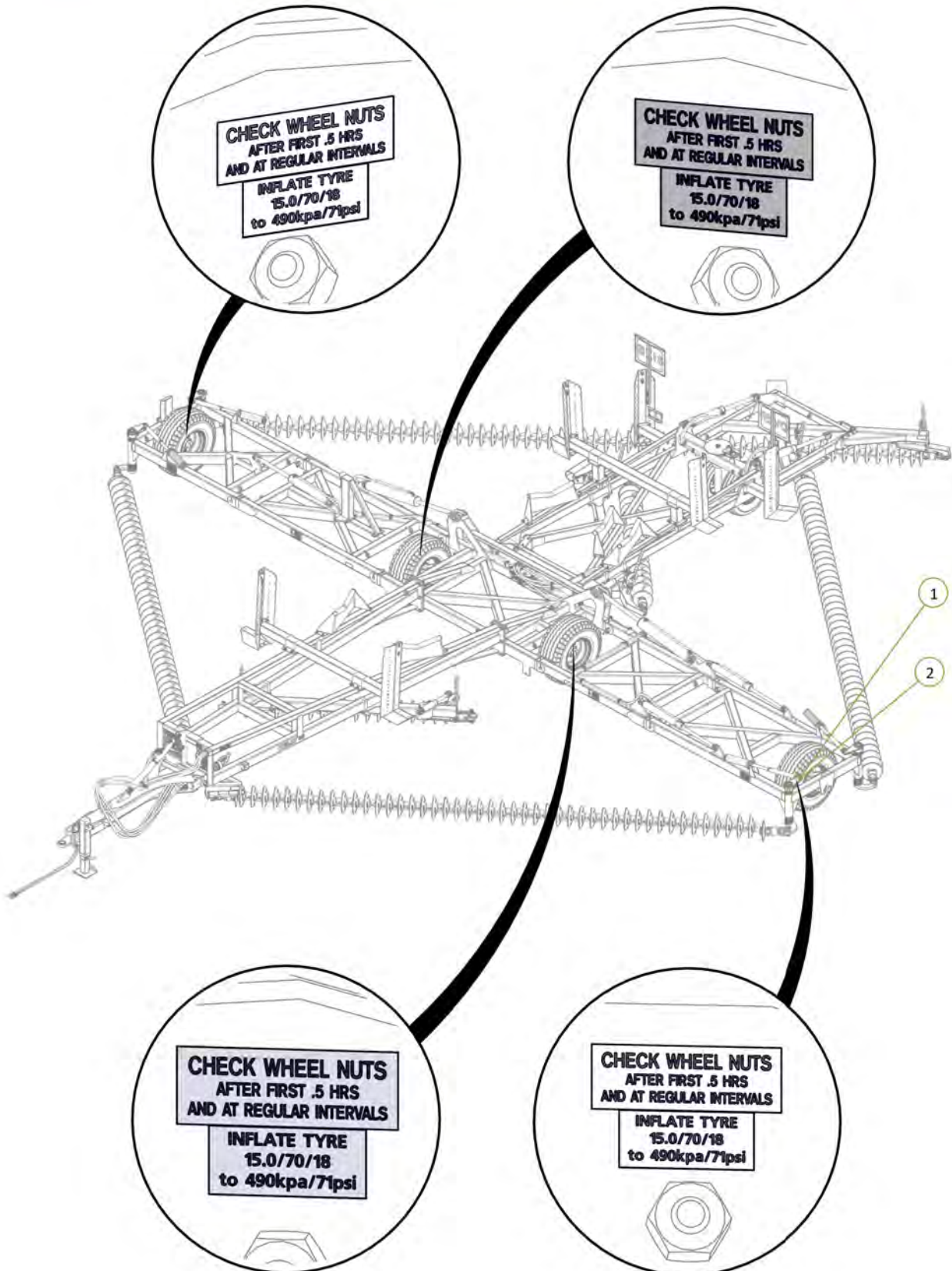
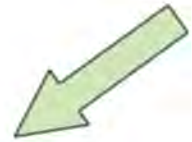

Item No.	Description	Number	Qty
1	Wheel Nut Decal	0801-S9	2
2	Decal- 11L-15 Tyre Inflation	0801-S8-11L-15	2

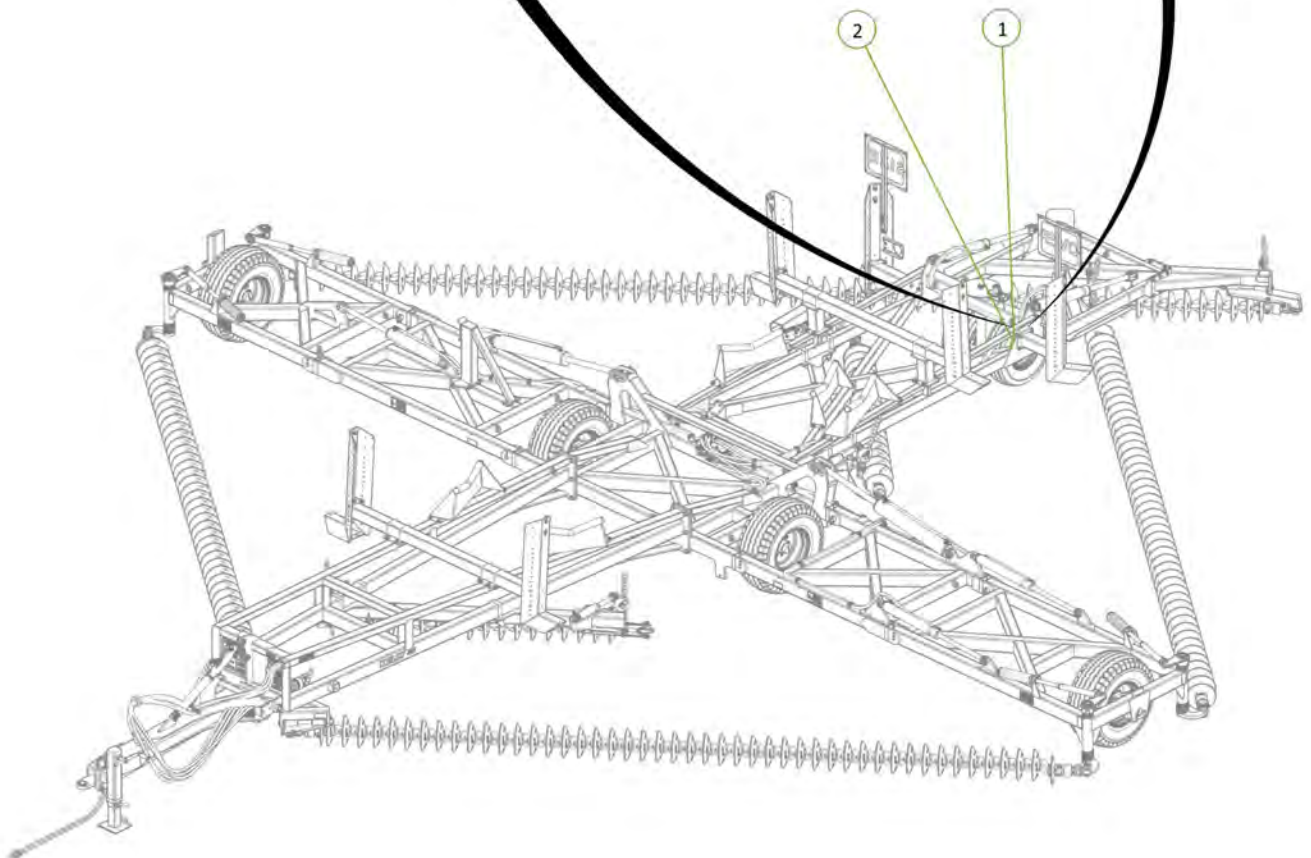
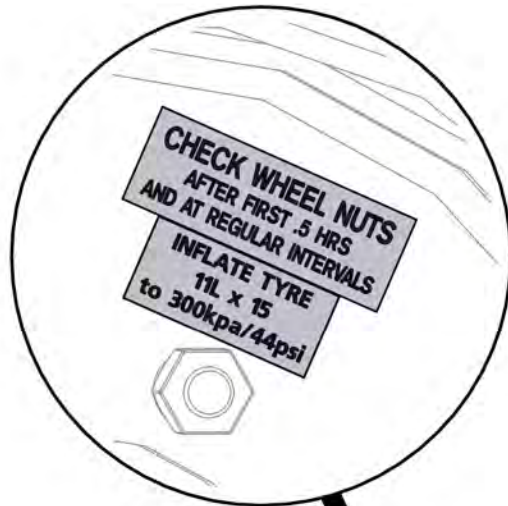
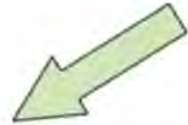

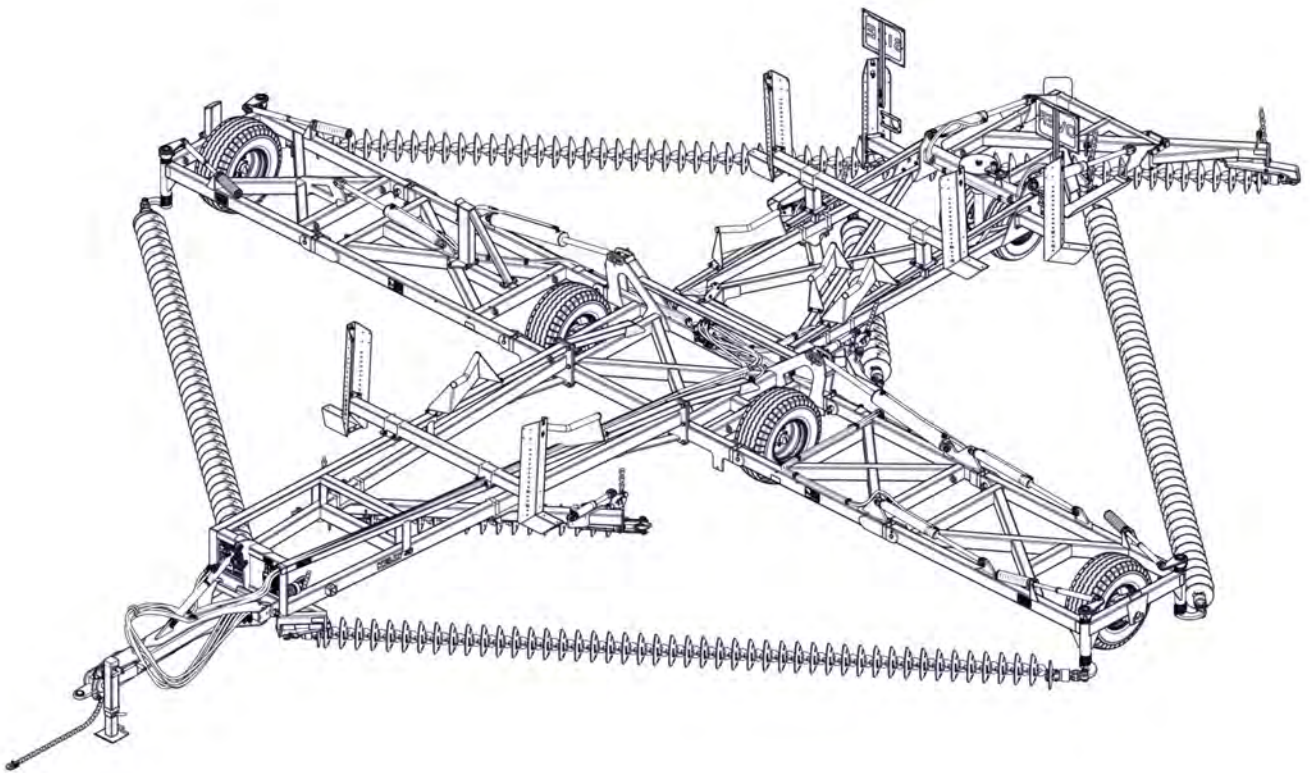

KELLY

Section 4 - Light Kit

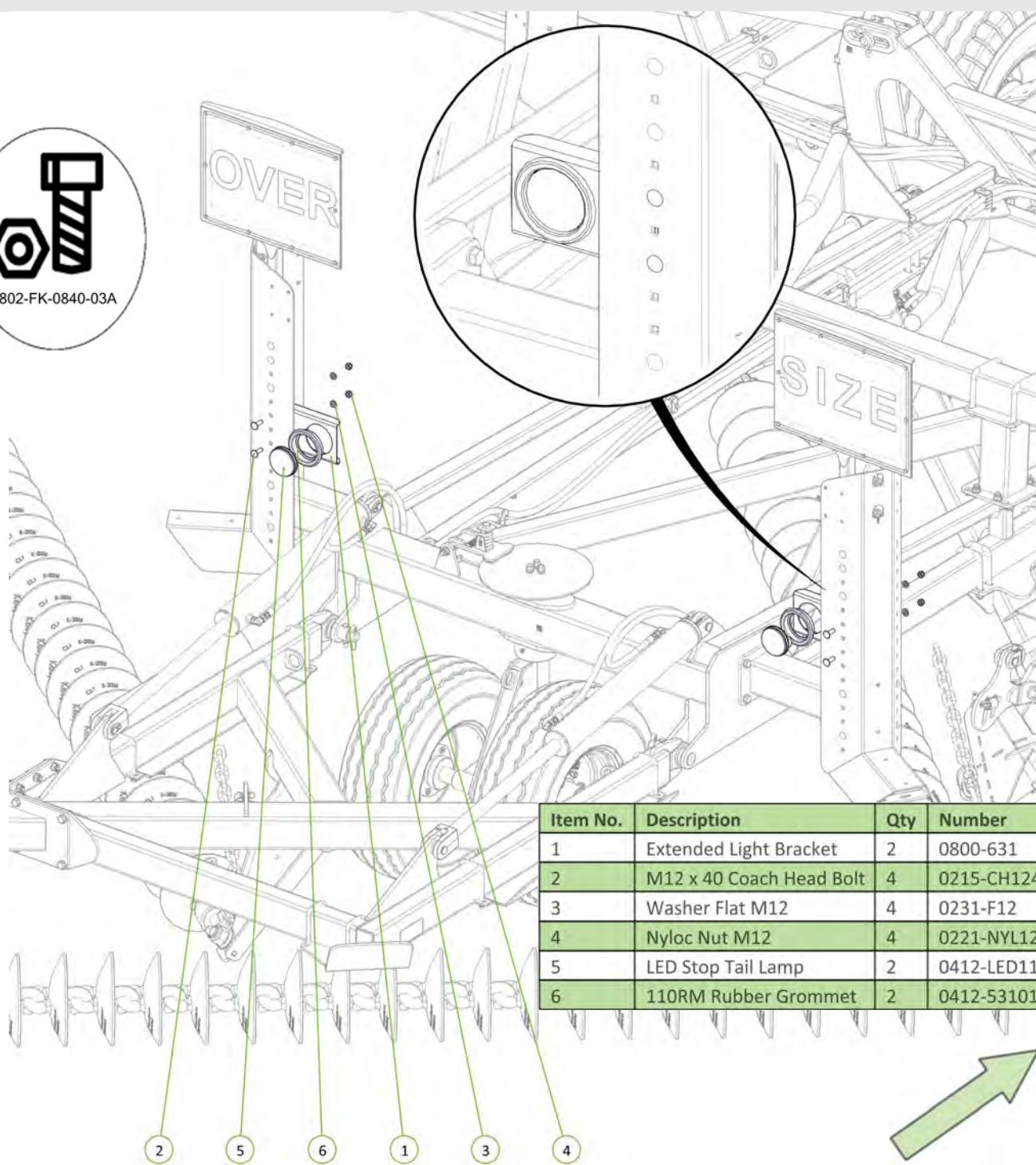

Item No.	Description	Qty	Number
1	Extended Light Bracket	2	0800-631
2	M12 x 40 Coach Head Bolt	4	0215-CH1240
3	Washer Flat M12	4	0231-F12
4	Nyloc Nut M12	4	0221-NYL12
5	LED Stop Tail Lamp	2	0412-LED110RM
6	110RM Rubber Grommet	2	0412-53101RG

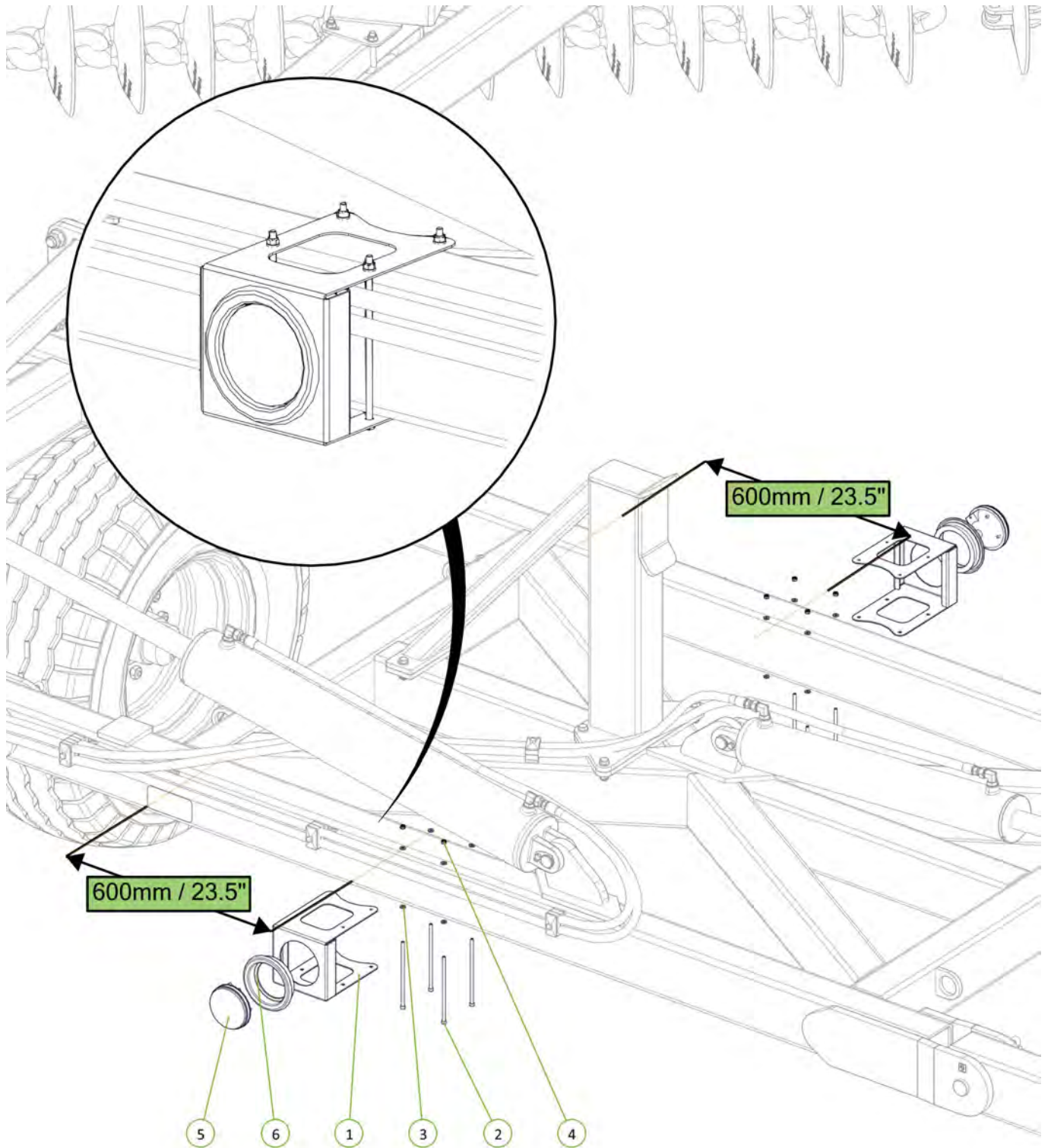

Item No.	Description	Qty	Number
1	Wing light bracket	2	0800-296
2	M6 x 170 ZP Socket Head Bolt	8	0211-SH6170
3	Washer Flat M6	16	0231-F6
4	Nyloc Nut M6	8	0221-NYL6
5	LED Rear Indicator Lamp	2	0412-LED110AM
6	0412-53101RG-3	2	0412-53101RG



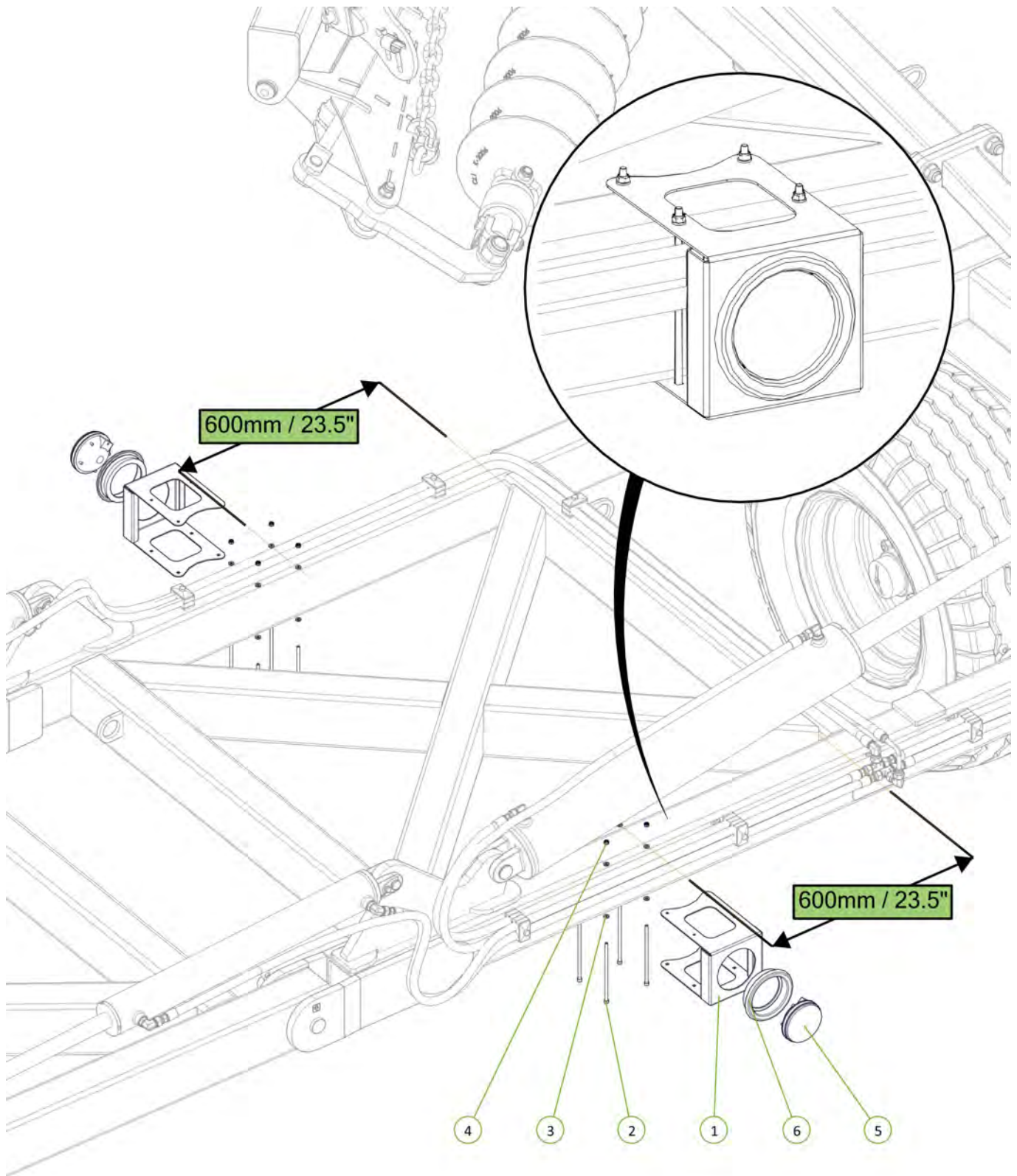

Item No.	Description	Qty	Number
1	Wing light bracket	2	0800-296
2	M6 x 170 ZP Socket Head Bolt	8	0211-SH6170
3	Washer Flat M6	16	0231-F6
4	Nyloc Nut M6	8	0221-NYL6
5	LED Rear Indicator Lamp	2	0412-LED110AM
6	110RM Rubber Grommet	2	0412-53101RG



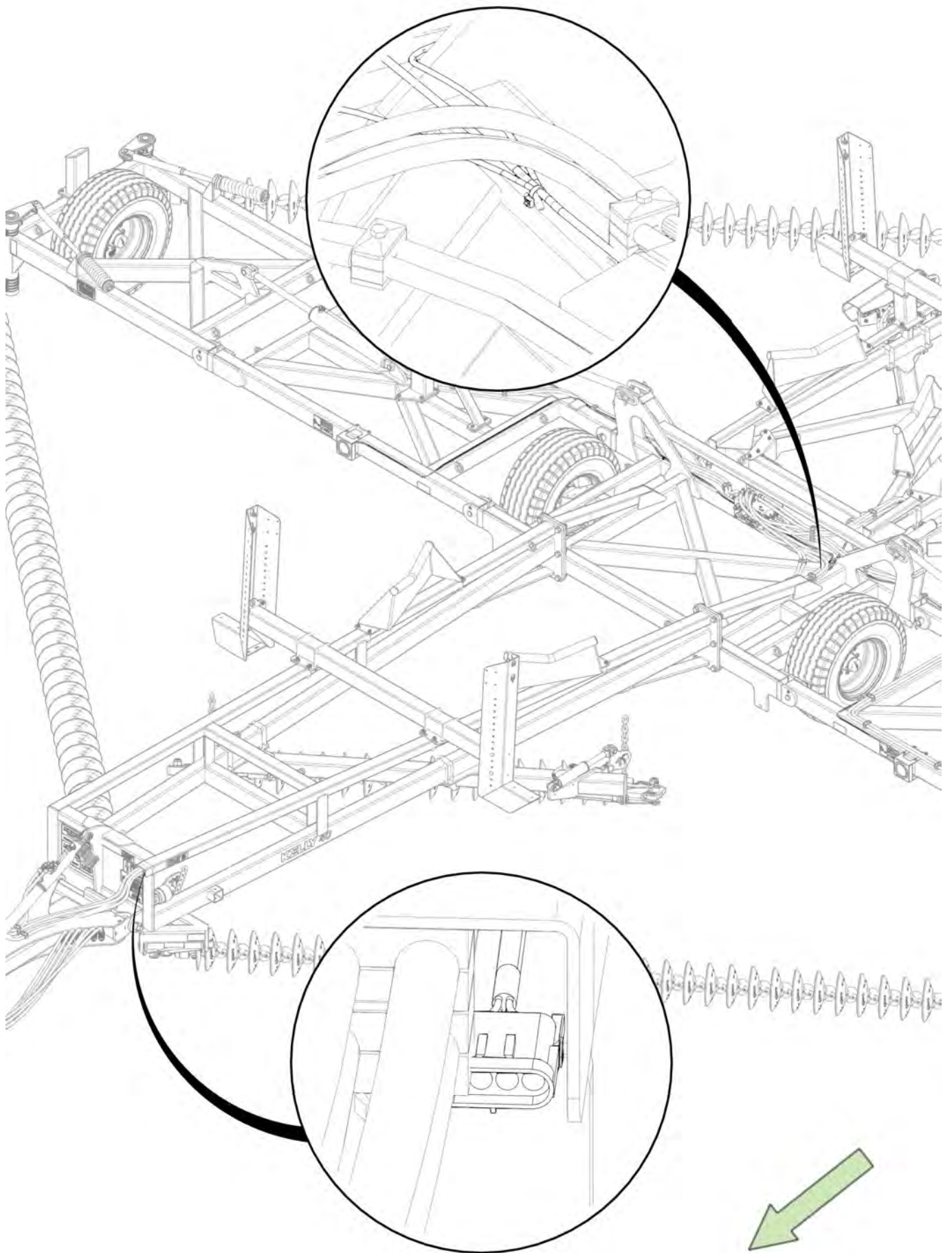

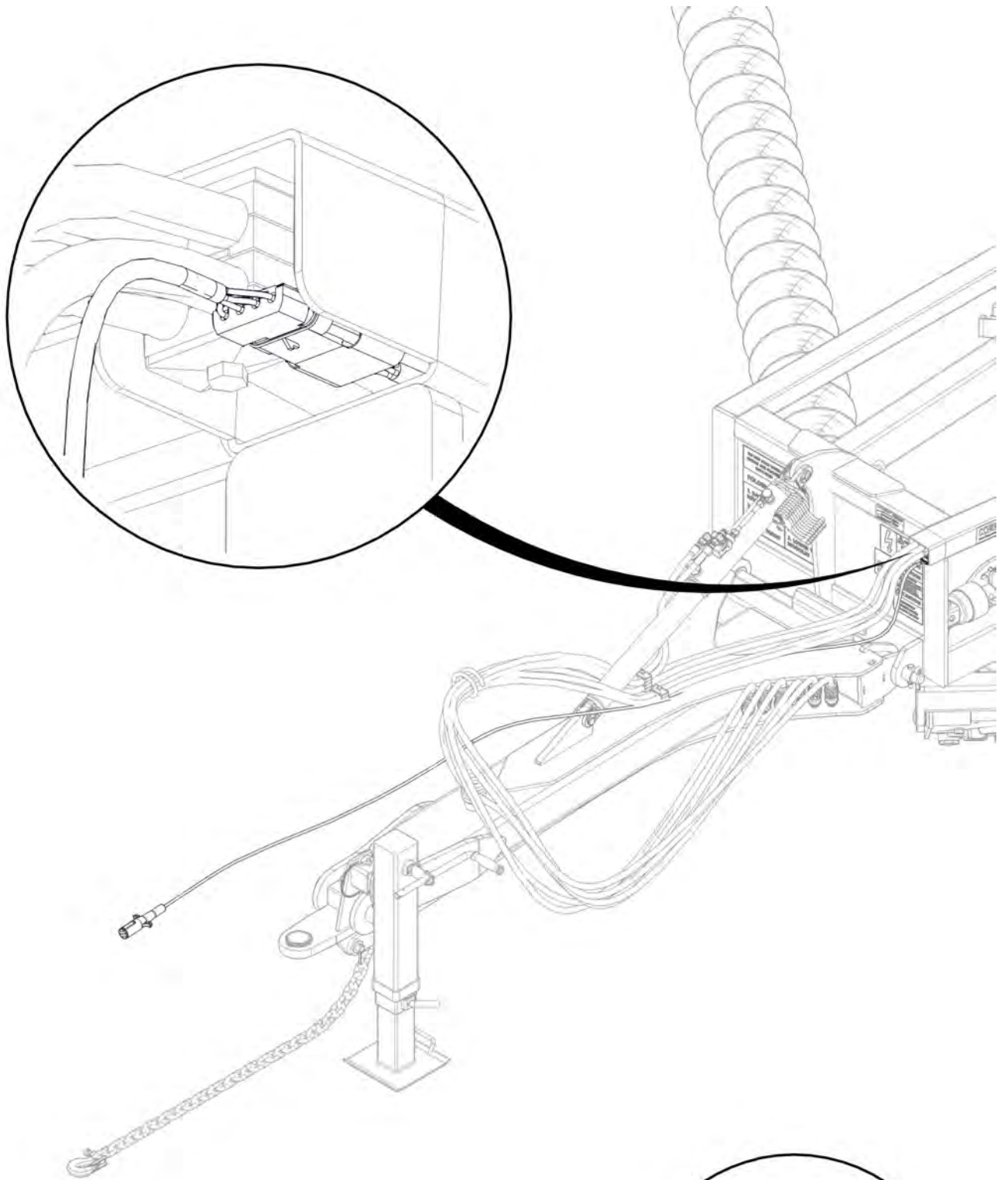

Where required secure loom to hydraulic hoses or tabs provided

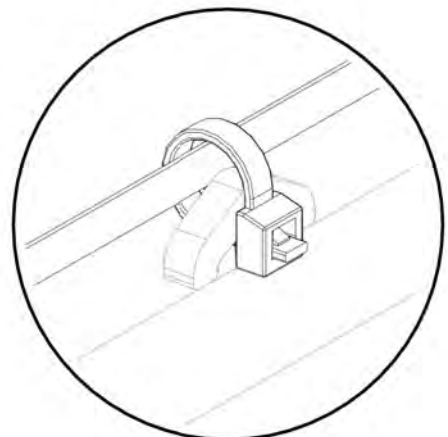

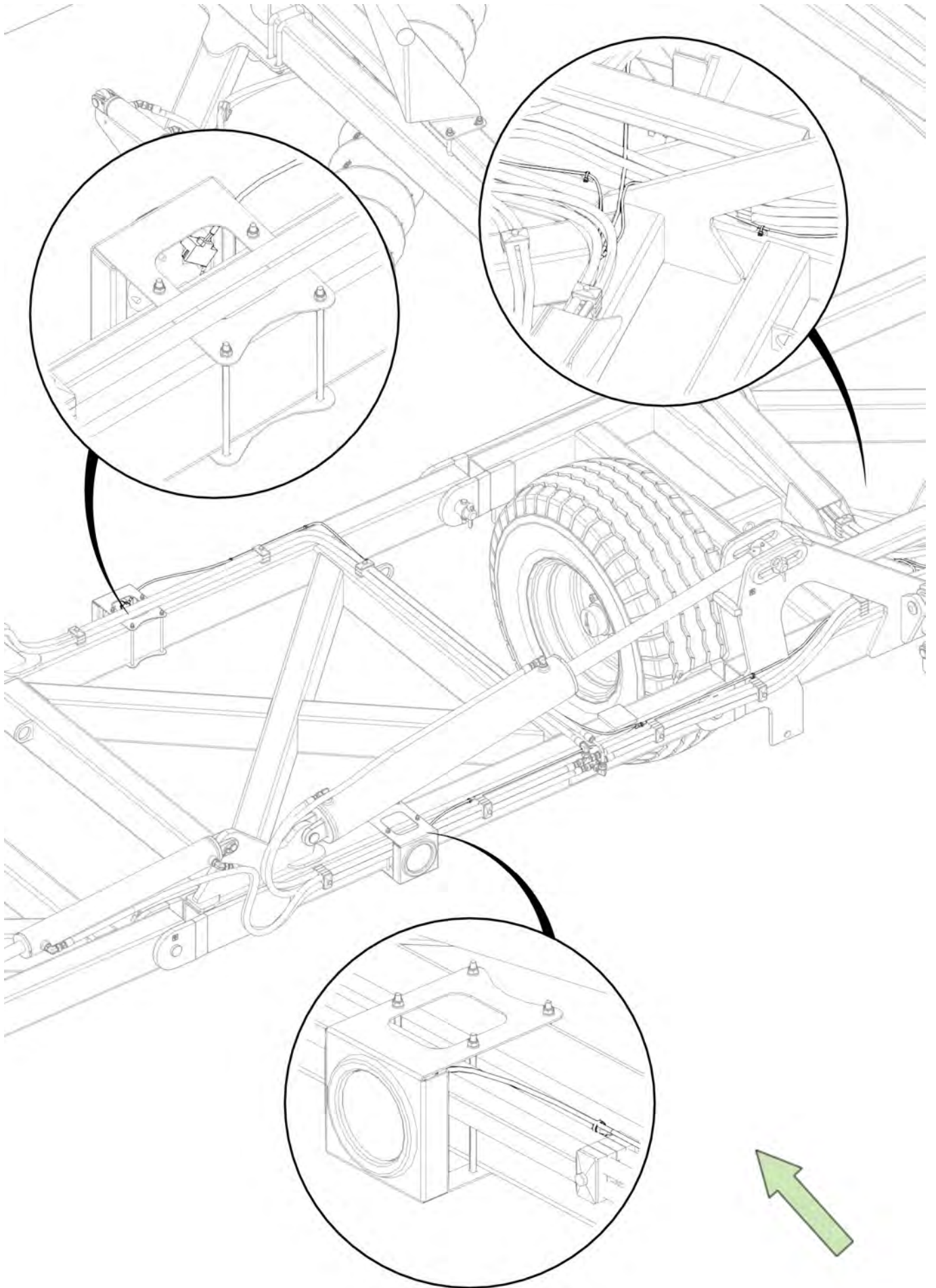

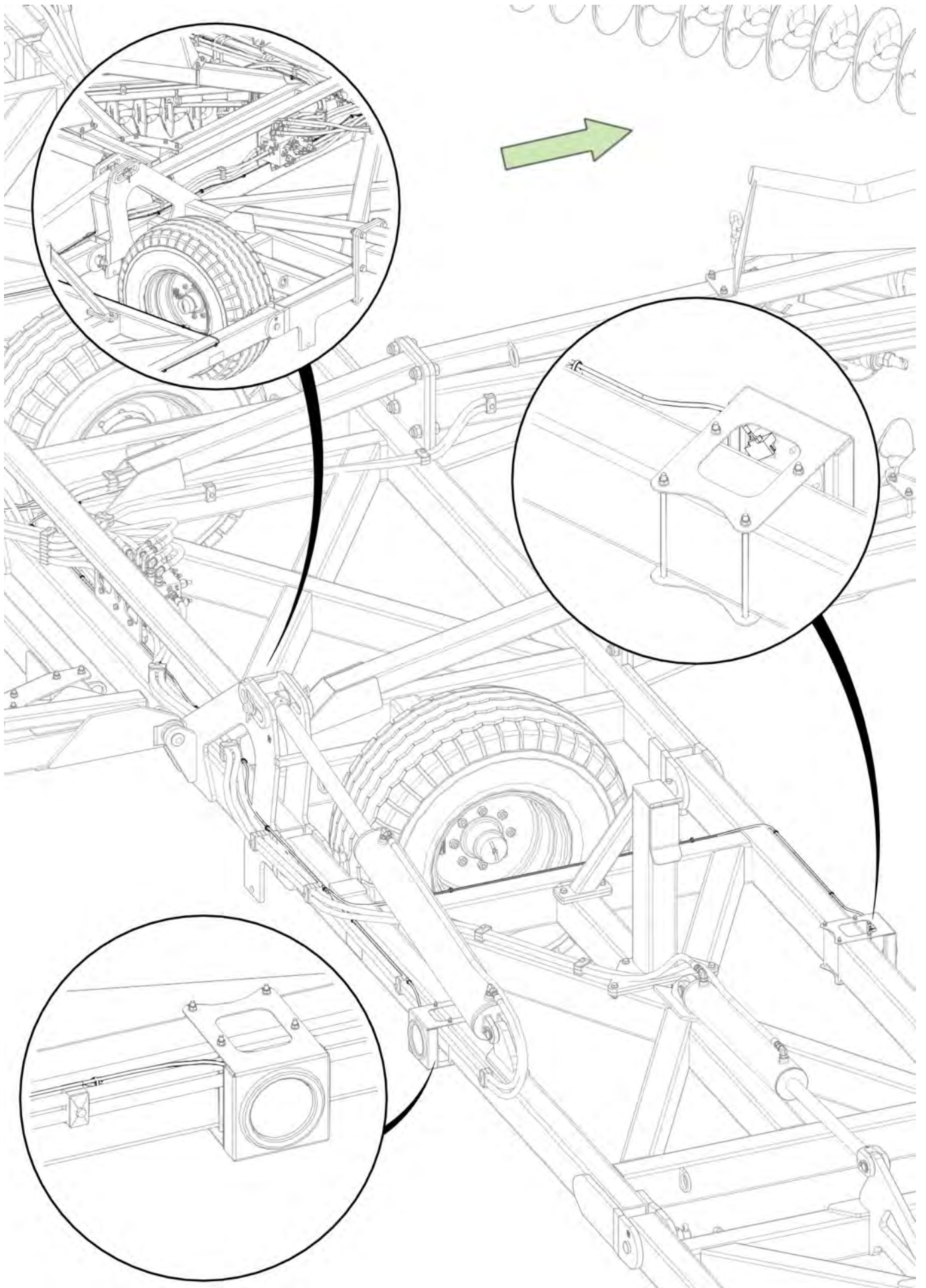

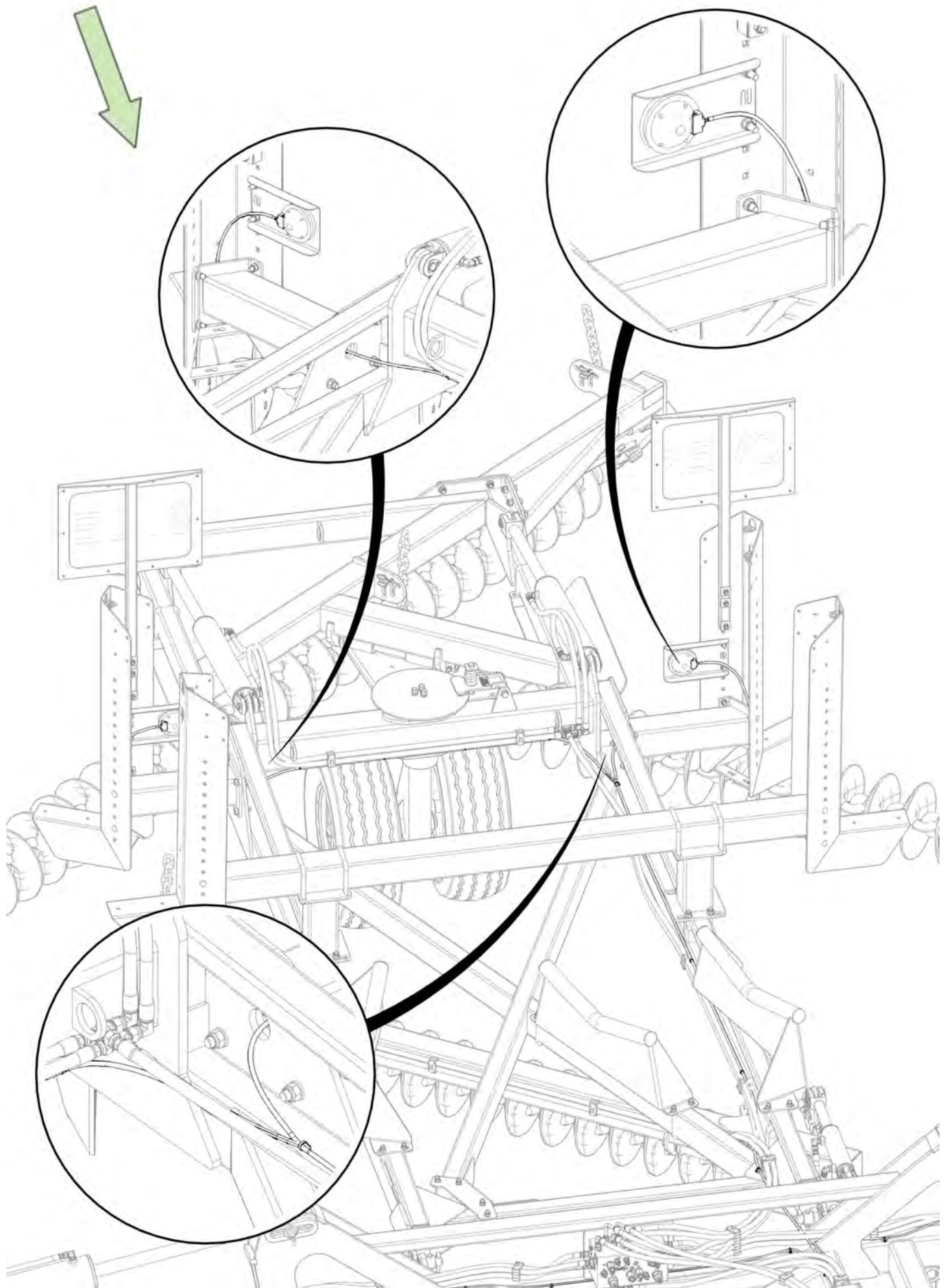



Section 5 - Chain Assembly

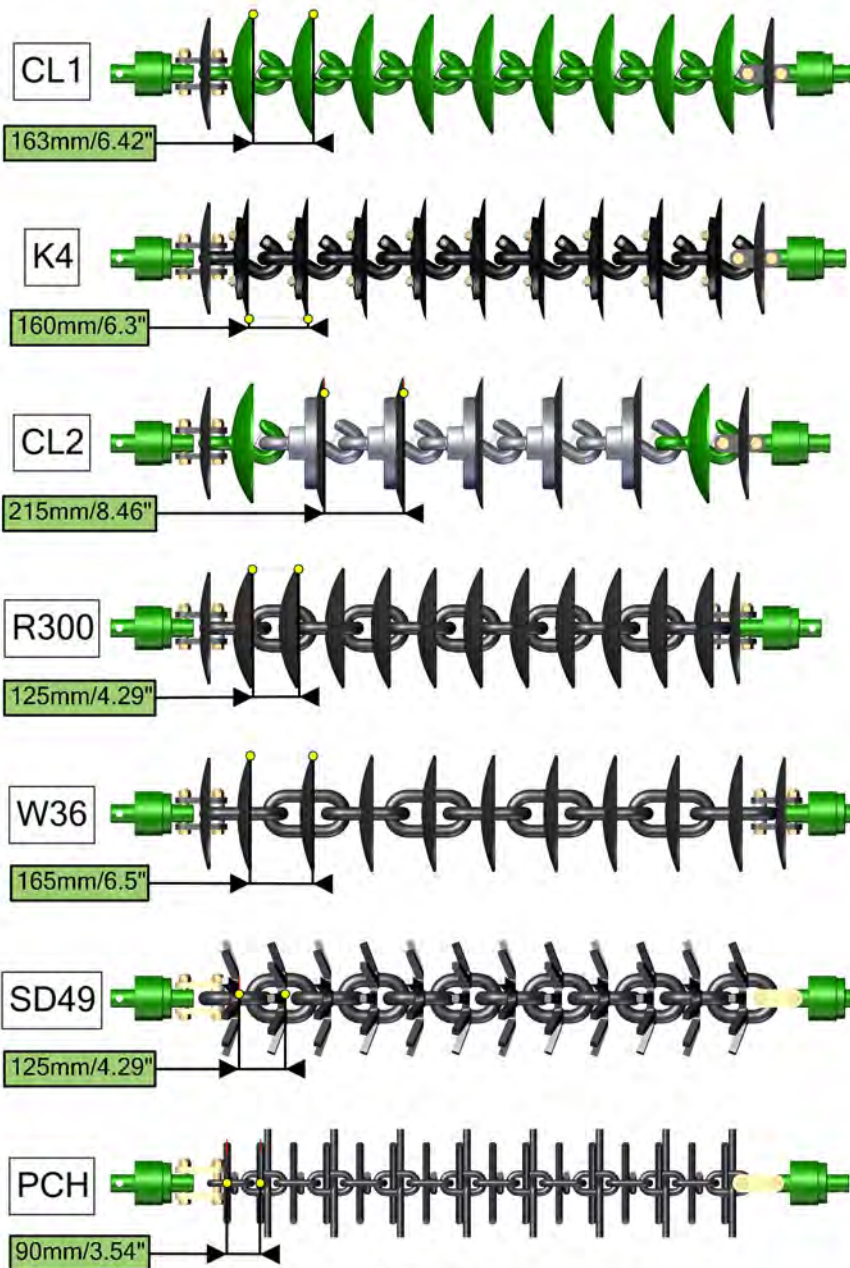

K4 Disc Chain

Item No.	Description	Number
1	Nyloc Nut M20	0221-NYL20
2	M20 x 110 Class 10.9 ZP Short Thread Bolt	0211-20110ST
3	20mm Bolt Swivel Unit	0802-PCHB55
4	Tie Plate Disc 20mm	0802-DCTP-20
5	Disc Chain Spacer	0801-253755
6	K4 Disc Assembly	0803-K4
7	M12 x 55 Class 8.8 ZP Bolt	0211-1255
8	Nyloc Nut M12	0221-NYL12

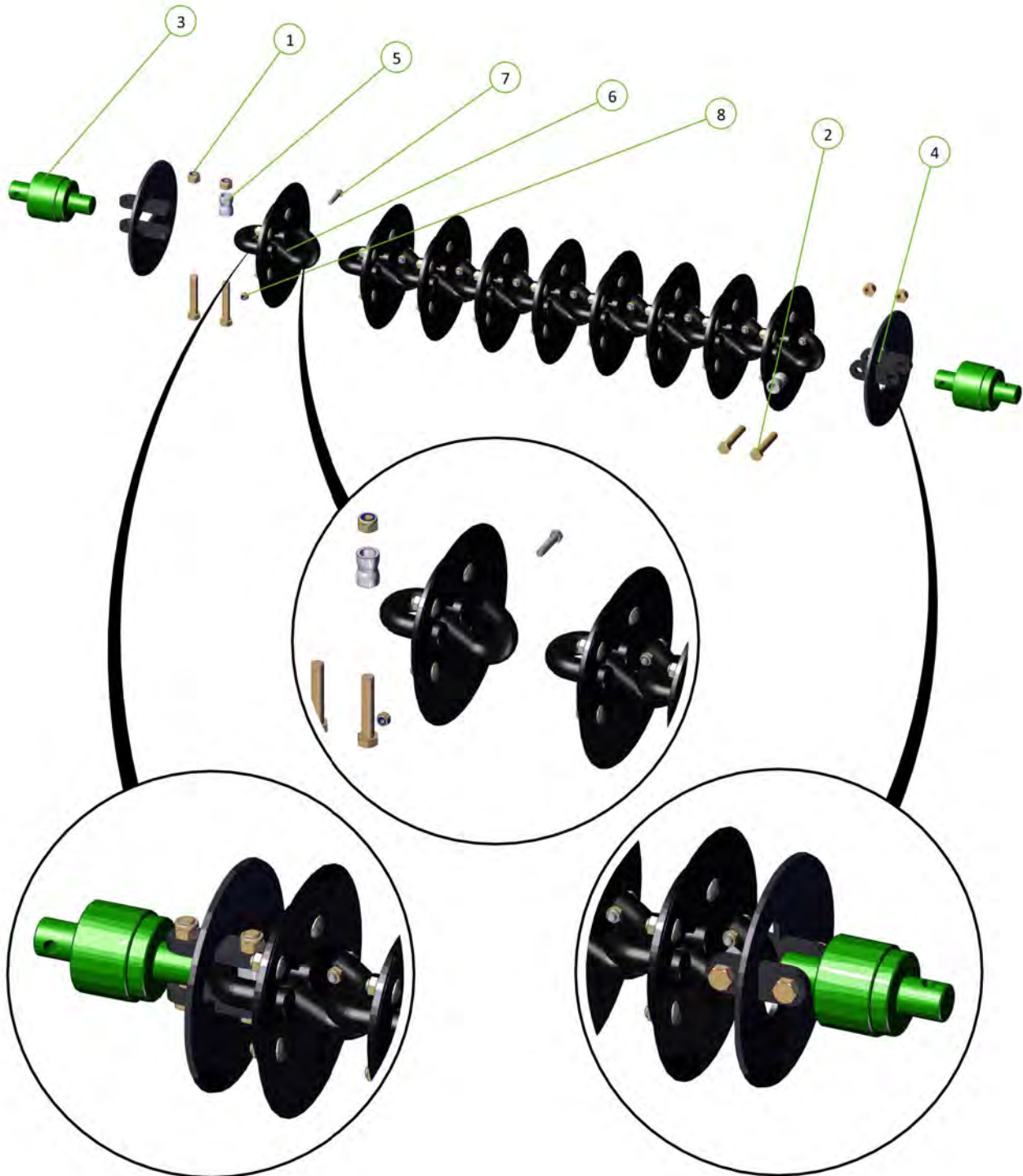
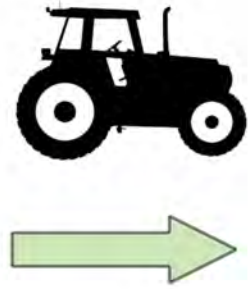

K4 Weight Assembly on Modules

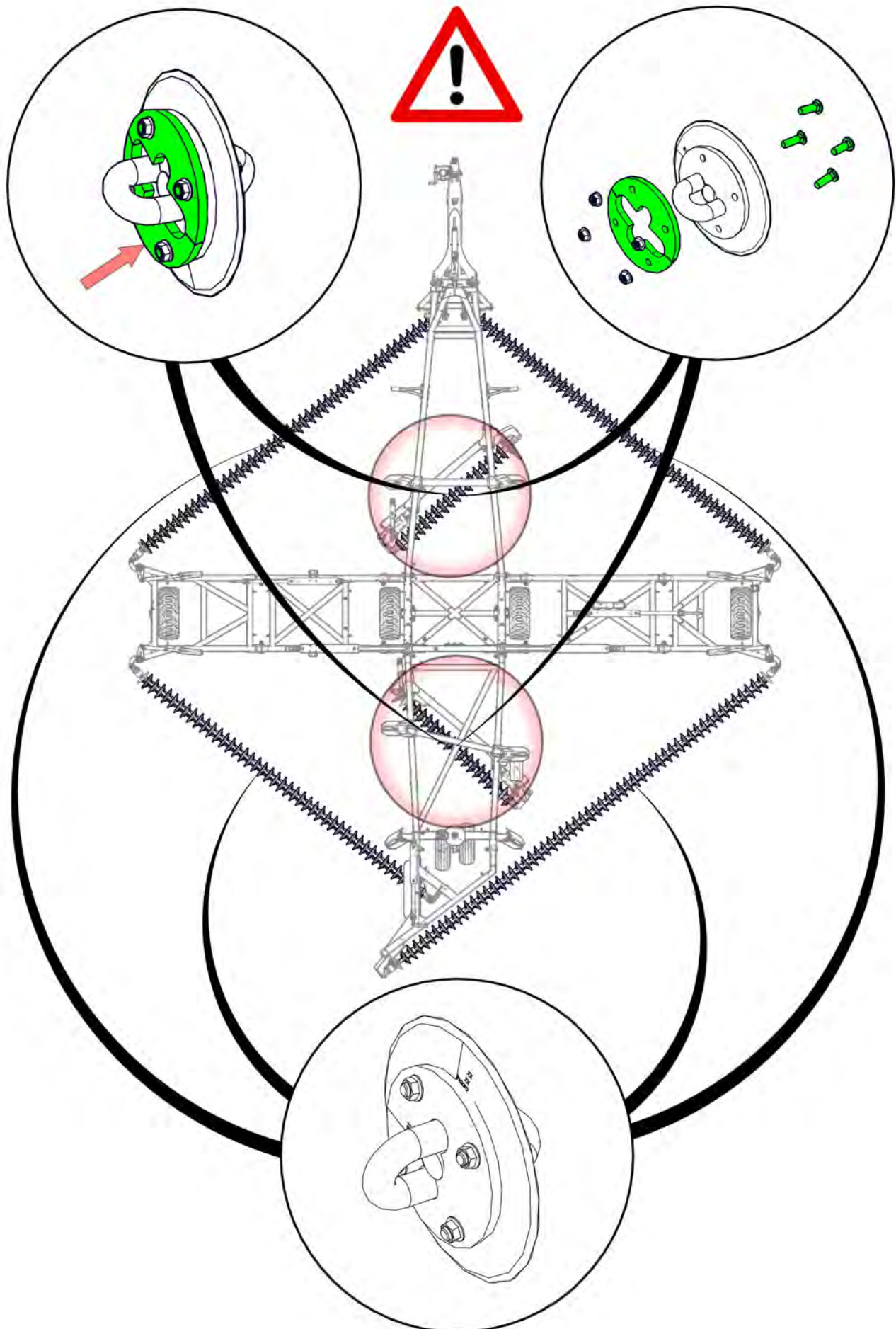

CL2 Disc Chain

Item No.	Description	Number
1	Nyloc Nut M20	0221-NYL20
2	M20 x 110 Class 10.9 ZP Short Thread Bolt	0211-20110ST
3	20mm Bolt Swivel Unit	0802-PCHB55
4	Tie Plate Disc 20mm	0802-DCTP-20
5	Disc Chain Spacer	0801-253755
6	CL2-Link Assembly	0803-CL2
7	Roll Pin Zinc Plated 3/8" x 2"	0262-3-8X2
8	CL1 Disc Chain Link	0803-CL1

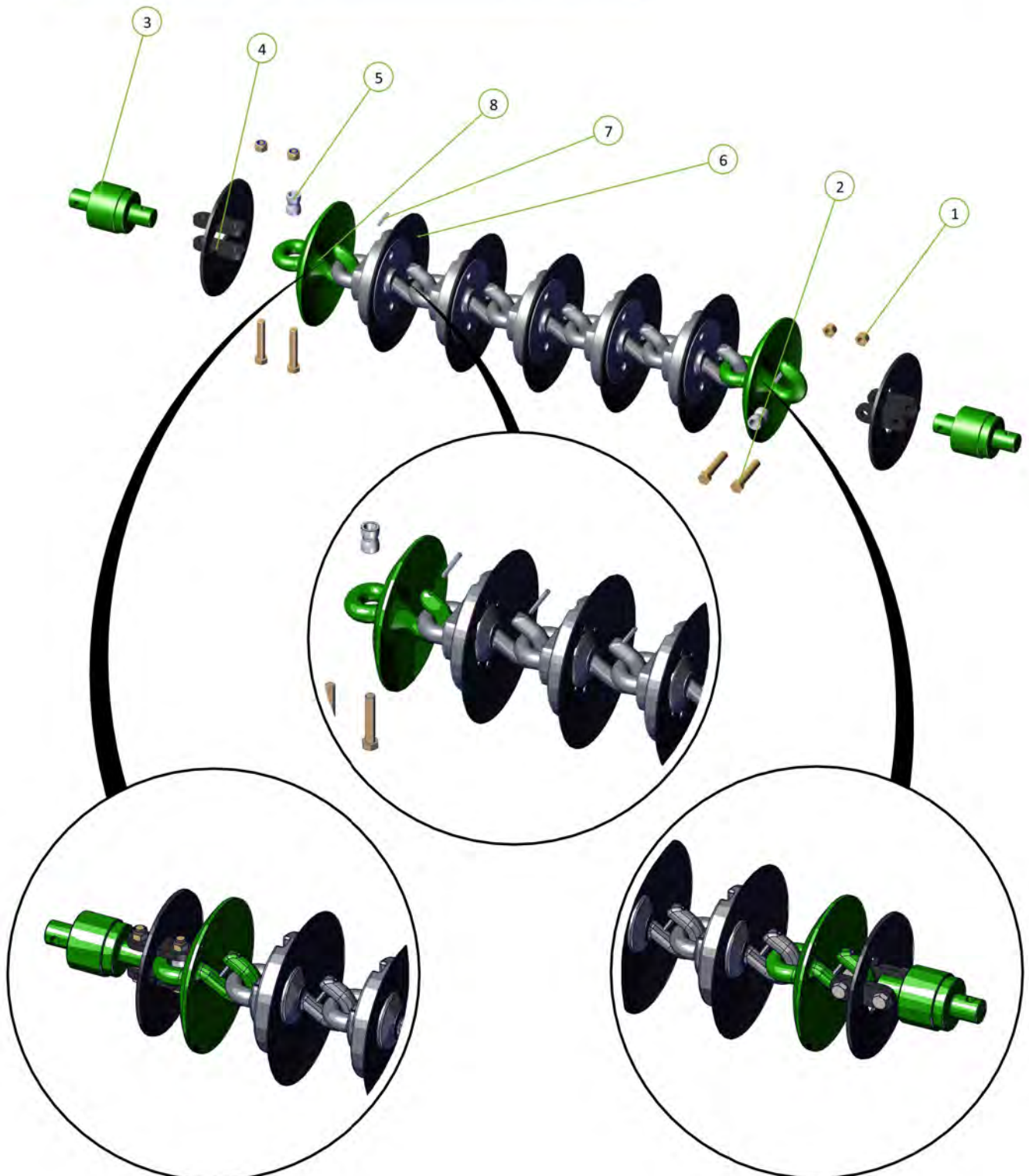

CL2 Disc Chain Layout

Set	CL2	CL1
Front Left	35	2
Front Right	35	2
Front Modules	10	3
Front Set	80	7
Rear Right	34	14
Rear Left	35	2
Rear Modules	11	2
Rear Set	80	18
Total	160	25

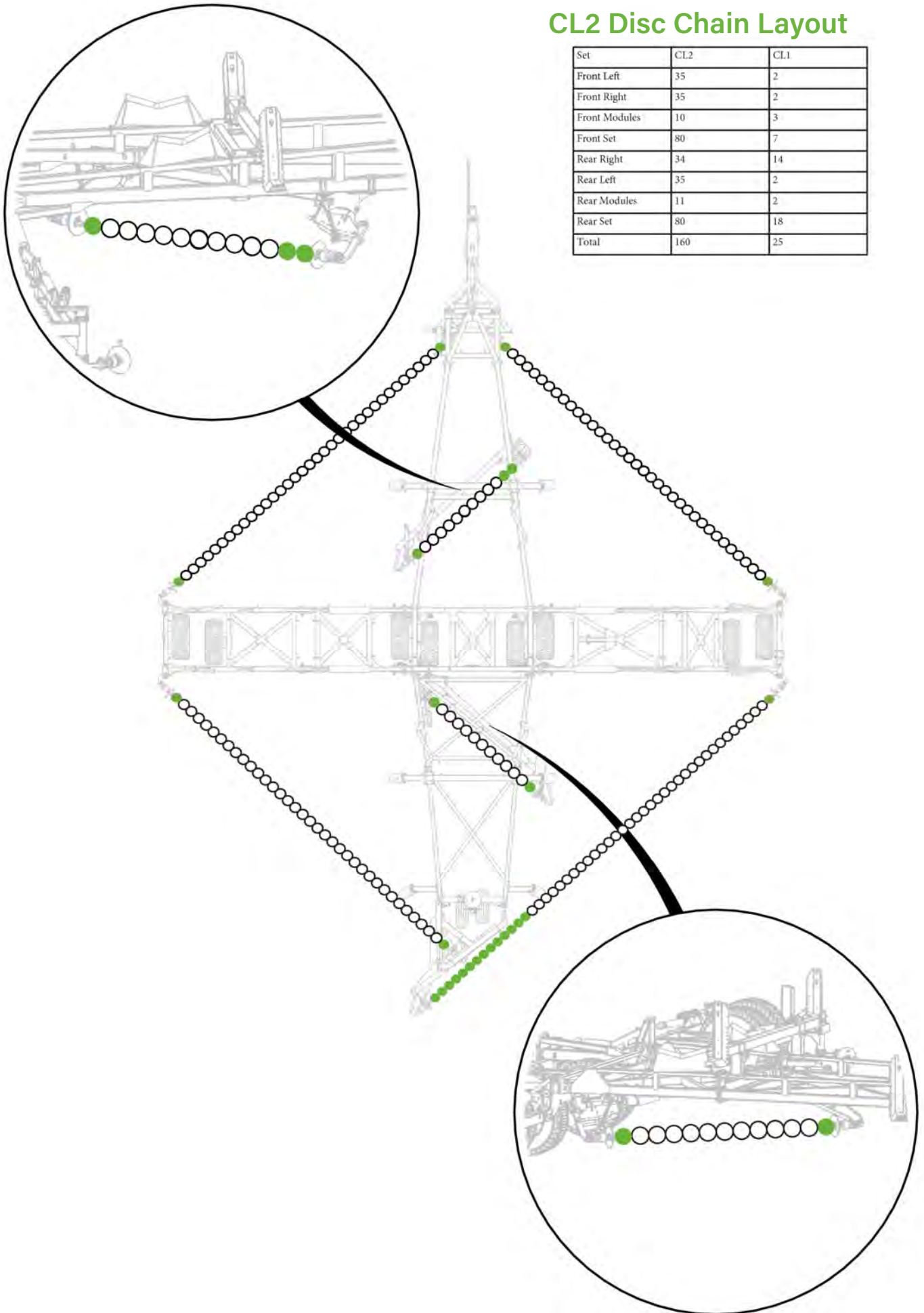

CL1 Disc Chain

Item No.	Description	Number
1	Nyloc Nut M20	0221-NYL20
2	M20 x 110 Class 10.9 ZP Short Thread Bolt	0211-20110ST
3	20mm Bolt Swivel Unit	0802-PCHB55
4	Tie Plate Disc 20mm	0802-DCTP-20
5	Disc Chain Spacer	0801-253755
6	Roll Pin Zinc Plated 3/8" x 2"	0262-3-8X2
7	CL1-B Chain Disc Link	0803-CL1

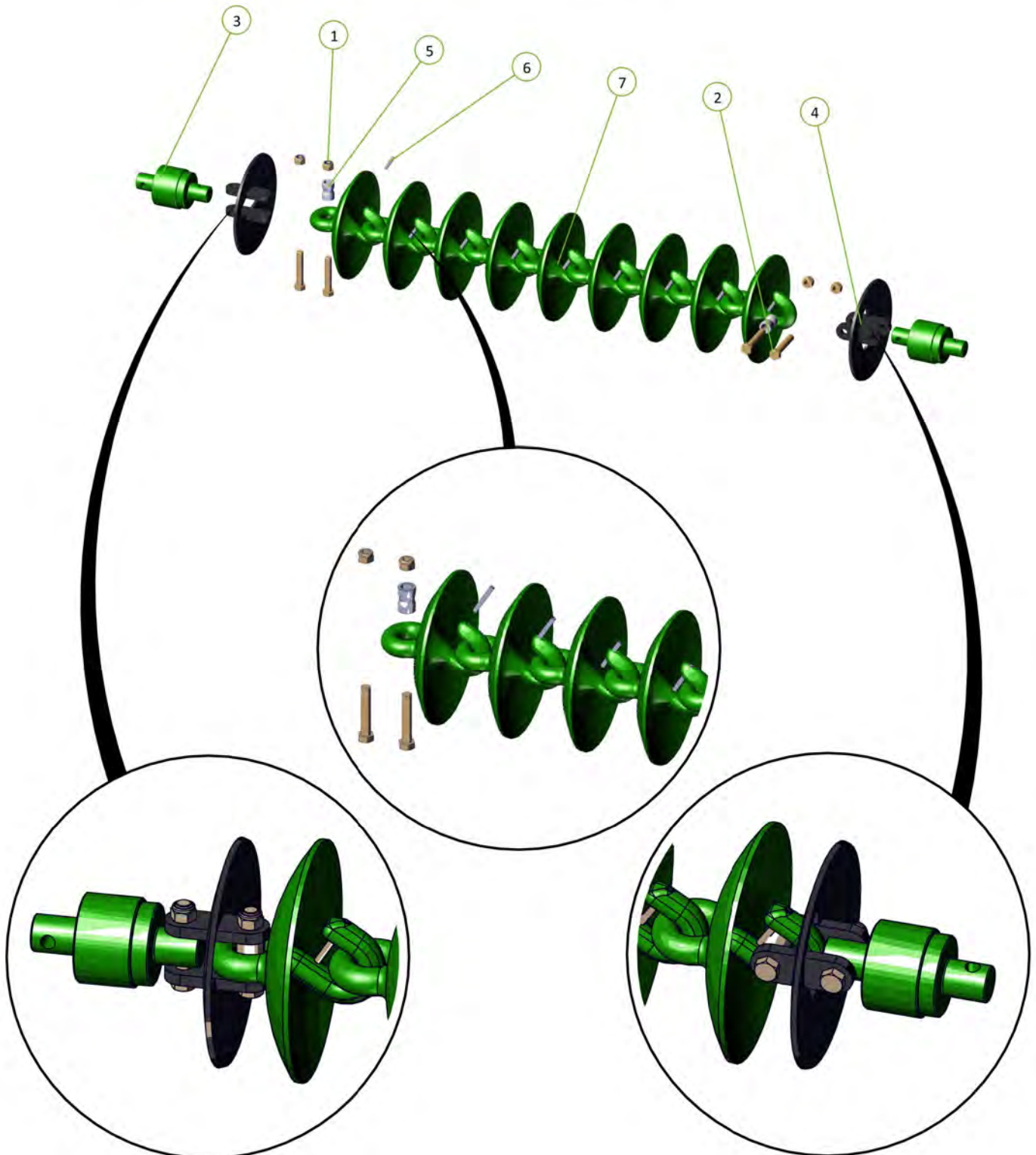

R300 Disc Chain

Item No.	Description	Number
1	Nyloc Nut M20	0221-NYL20
2	M20 x 110 Class 10.9 ZP Short Thread Bolt	0211-20110ST
3	20mm Bolt Swivel Unit	0802-PCHB55
4	Tie Plate Disc 20mm	0802-DCTP-20
5	Disc Chain Spacer	0801-253755
6	R300 Chain Link	0803-R300

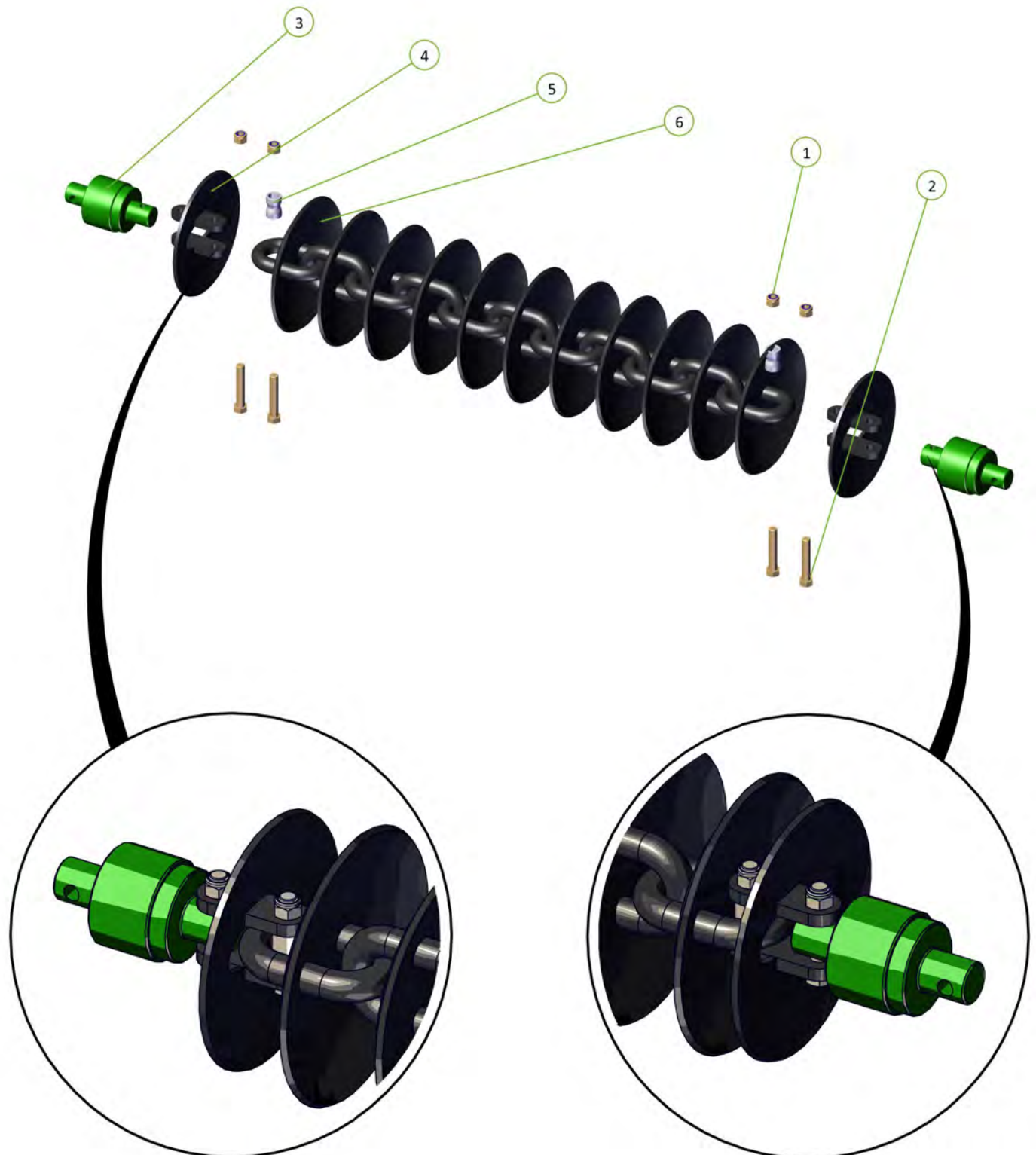

W36 Disc Chain

Item No.	Description	Number
1	Nyloc Nut M20	0221-NYL20
2	M20 x 110 Class 10.9 ZP Short Thread Bolt	0211-20110ST
3	20mm Bolt Swivel Unit	0802-PCHB55
4	Tie Plate Disc 20mm	0802-DCTP-20
5	Disc Chain Spacer	0801-253755
6	W36/25 Chain Link	0803-W36

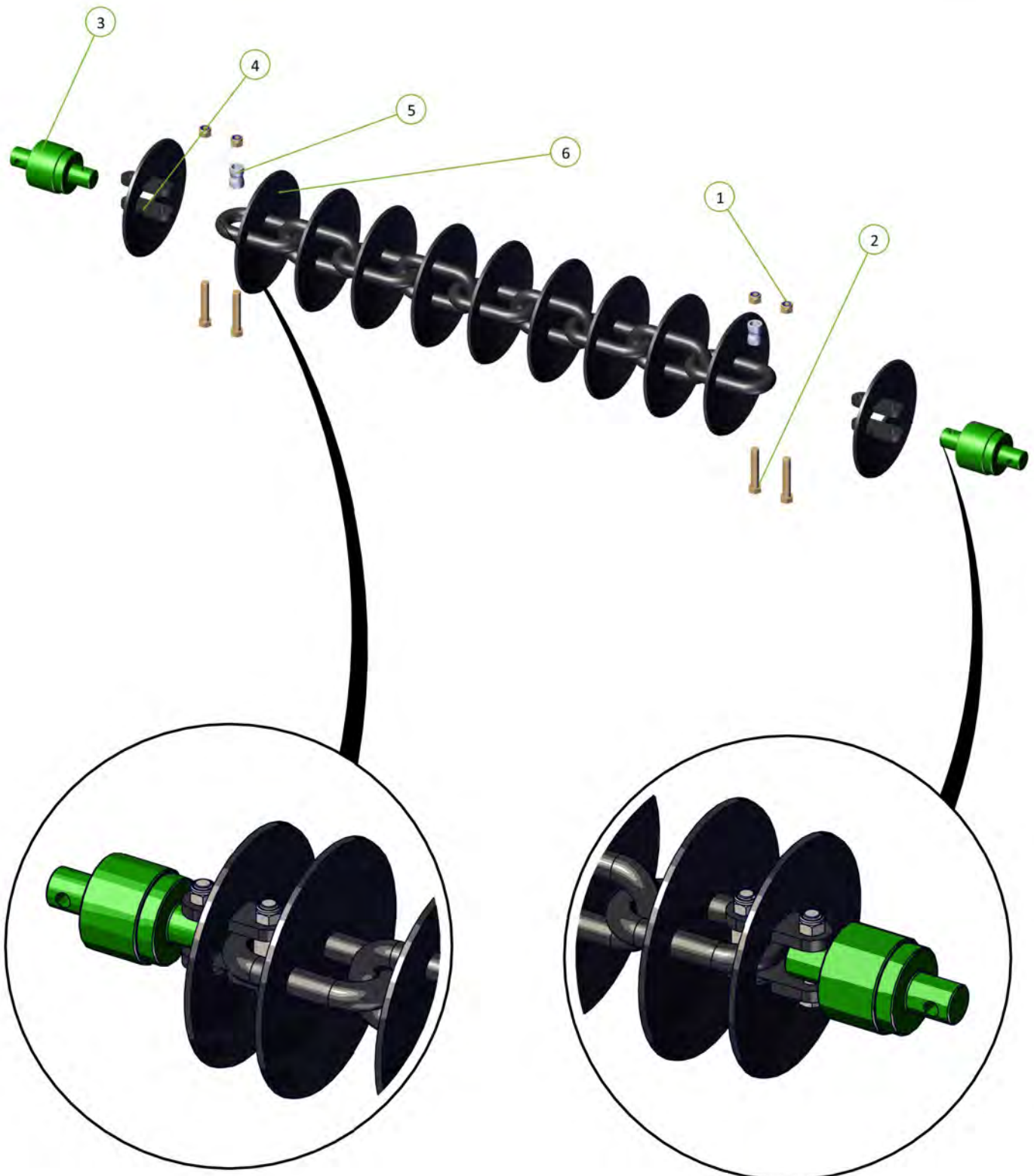

Spike Disc Chain

Item No.	Description	Number
1	Nyloc Nut M20	0221-NYL20
2	M20 x 110 Class 10.9 ZP Short Thread Bolt	0211-20110ST
3	20mm Bolt Swivel Unit	0802-PCHB55
4	Tie Plate For 20mm Bolt	0800-83.2
5	Disc Chain Spacer	0801-253755
6	10 Spike Disc Chain 49/27/5	0803-SD49

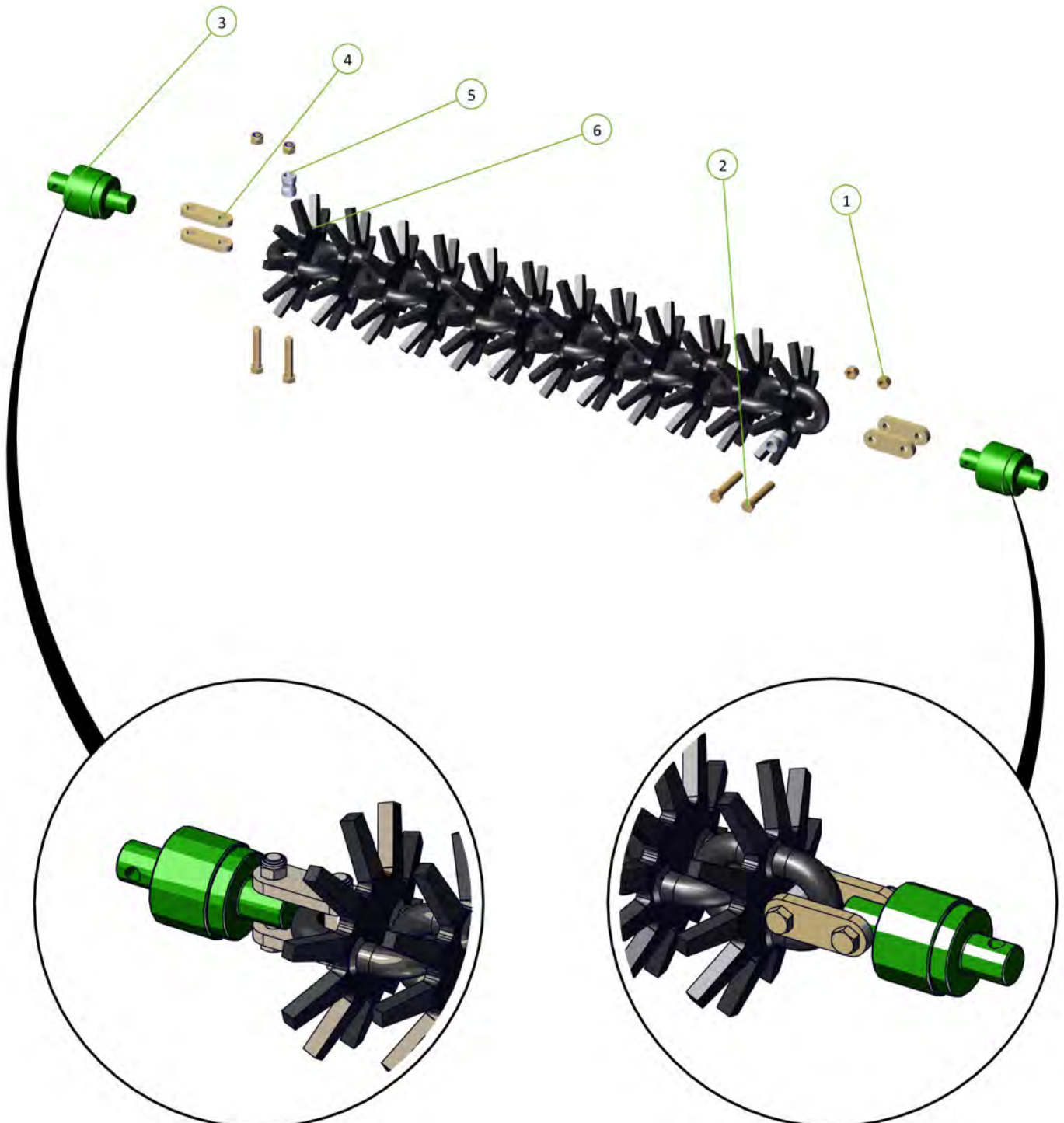

Prickle Chain

Item No.	Description	Number
1	Nyloc Nut M20	0221-NYL20
2	M20 x 110 Class 10.9 ZP Short Thread Bolt	0211-20110ST
3	20mm Bolt Swivel Unit	0802-PCHB55
4	0800-83.2	0800-83.2
5	Prickle Chain	0803-PCH

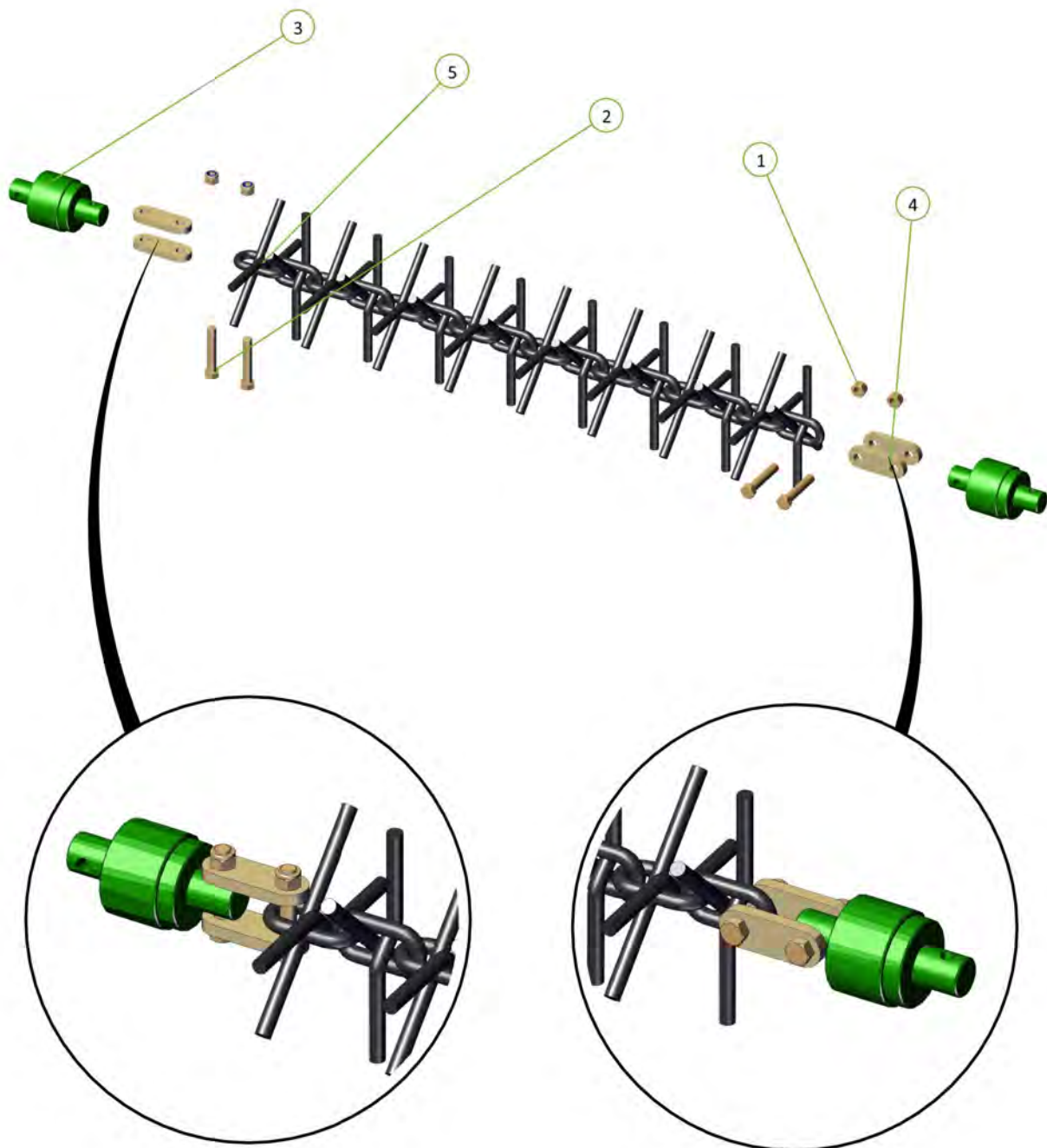
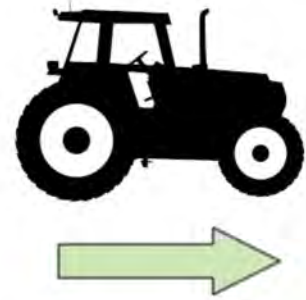



Section 6 - Specifications

Wiring Diagram

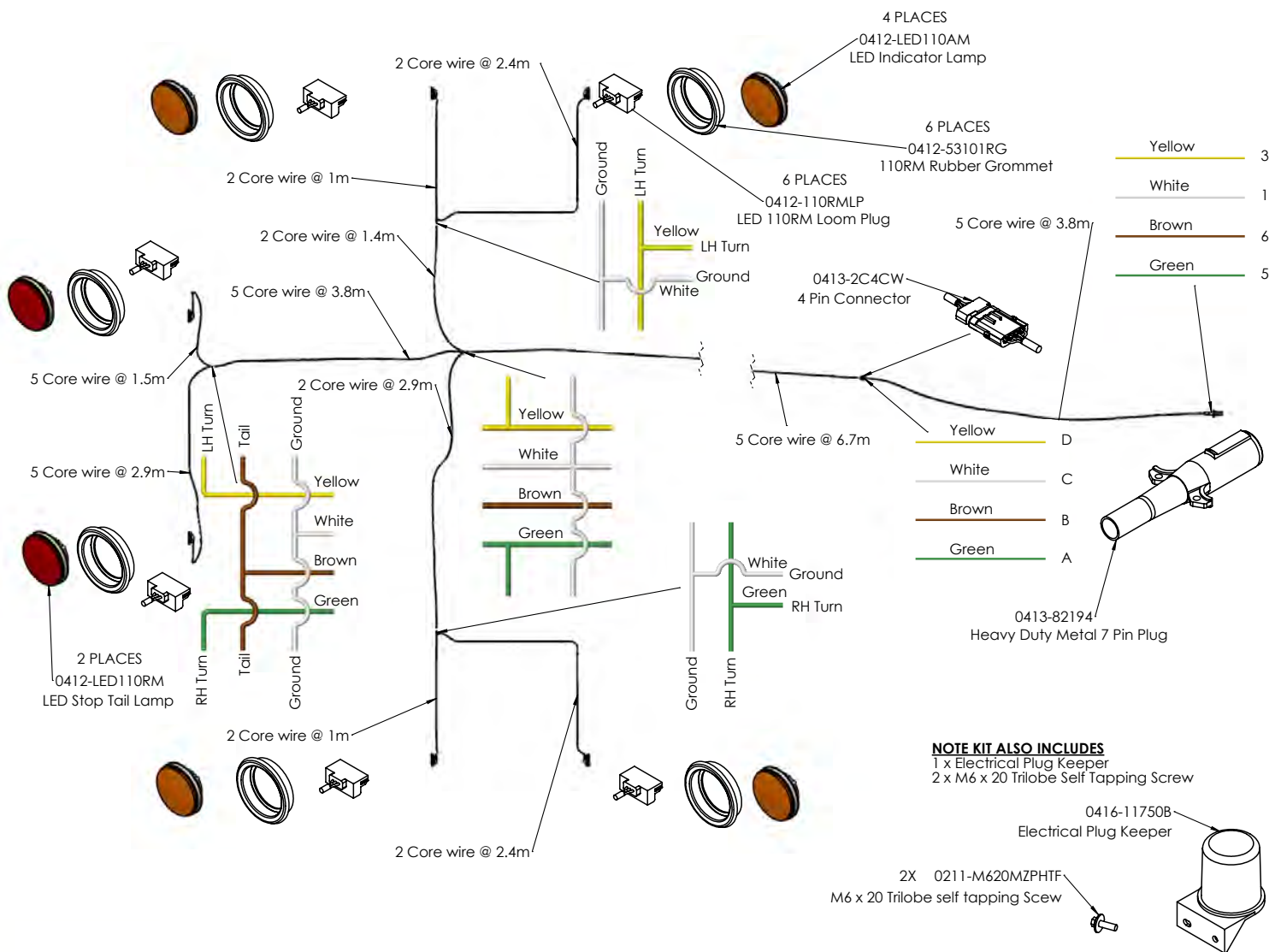

Operating speeds

Operating speeds for normal conditions	
Chain type	Speed
Prickle Chain	6-10 Mph / 10-16 kmph
Disc Mulch Chain	6-8 Mph / 10-12 kmph
Transport / towing on roads	15 Mph / 25 kmph

Tire pressure

Tire size	Ply	PSI	KPA
16.5L x 16.1	14	36	250
H40 x 14.5-19	26	60	410
11L - 15	10	44	300
15.5/80/24	16	58	400
16.5/85/24	16	55	380
550/60/22.5	16	40	280
400/60/22.5	16	50	350
12.5/80/18	14	85	590
15.0/70/18	14	71	490

Chain Harrow specifications

Model	40'/12m
Working width	43'4"/13.2m
Transport width	11'6"/3.5m
Transport height	12'2"/3.7m
Transport length	52'6"/14.3m

Disc Chain Lengths

Model 40ft		Length	CL2	CL1	W36	R300	SD49	Prickle chain
			CL2 disc chain also requires CL1 disc chain					
40'	Front right	25'/7.6m	CL2 - 32 CL1 - 2	46	46	60	60	84
	Front left	25'/7.6m	CL2 - 32 CL1 - 2	46	46	60	60	84
	Rear right	29.8'/9.1m	CL2 - 32 CL1 - 14	57	60	79	79	109
	Rear left	25'/7.6m	CL2 - 33 CL1 - 2	45	47	62	62	87
	Modules front	8.9'/2.7m	CL2 - 10 CL1 - 2	17	17	22	22	31
	Modules rear	8.9'/2.7m	CL2 - 11 CL1 - 2	16	17	22	22	31



Section 7 - Operation

Basic Operation

Unfolding:

1. Walk around and inspect the machine.
 - a. Check that chains are not hooked on framework
 - b. Check swivel bolts are in place and not broken
 - c. Check that height adjusting chains have not fallen out of their slotted plates during transport.
 - d. Ensure front lift cylinder depth stops are fully engaged on cylinder shaft.
2. Lower front A frame to working height.
3. Unfold wings holding the hydraulic lever until both the main center cylinder pins have centered in their slots. (If chain pulls tight during unfold, stop and inspect if chain is hooked)
4. Lower rear tail by holding hydraulic lever until tail and modules are completely lowered to working position.
5. Walk around and check that all chain links are straight and that working height of all swivels is correct for field conditions. Adjust if necessary.
6. Move off with all chains in working position. If necessary it is acceptable to raise front A pull to transport height. This will lift the front chains off the ground and reduce the load on the tractor. Lower the front A pull once moving satisfactorily.

Folding:

1. Lower the front A frame to working height. (This is important to ensure that all chains locate correctly in their transport rests).
2. Raise the Rear Tail and modules by holding the hydraulic lever until they come to a complete stop.
3. Fold the wings. They should move as follows; main center cylinders will retract, one or both, until the wings stand vertically. The left outer wing then the right outer wing will fold down.
4. Raise front A frame to transport height.
5. Walk around and check that chains have located correctly in transport rests.
(30' only, close wing transport lock valves).

Setting for correct chain tension

Wings

Use the spanner supplied. Loosen the lock nut adjacent to the tensioner assembly body. Turn the tension bolt clockwise to compress the coil spring. Correct tension is achieved when spring retains its set length when operator rolls the chain fore and aft on the ground. Retighten the lock nut.

Spring Compression Length

Compress Spring to 12.4" (330mm). When less than 4" (100mm) of thread remains visible on the adjustor bolt then a link must be removed from the chain.

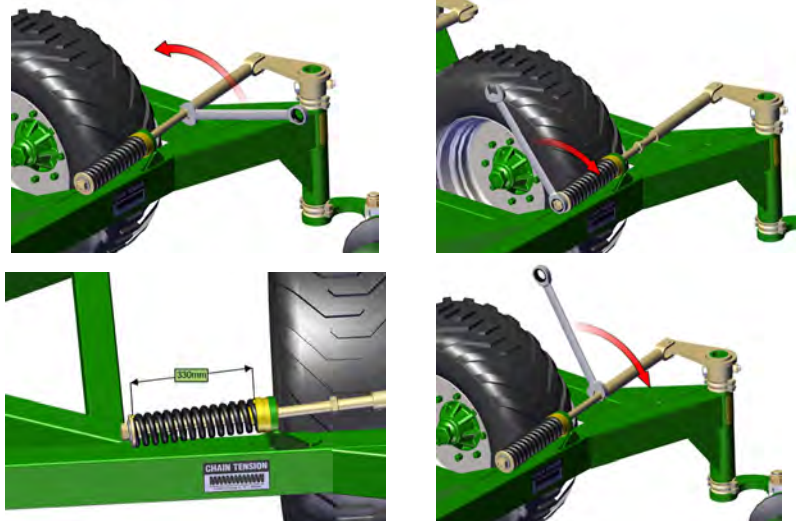

Modules

1. Loosen the lock nut on the module tension rod.
2. For correct chain tension, tighten the adjusting nut clockwise until the outer face of the spring retaining washer is flush with the face of the tension body. (Spring length of 330mm)
3. If more than 230mm (9") of the module tension rod extends past the face of the tension body, then remove one link from the chain set to maintain correct chain tension.
4. Retighten the Lock nut.

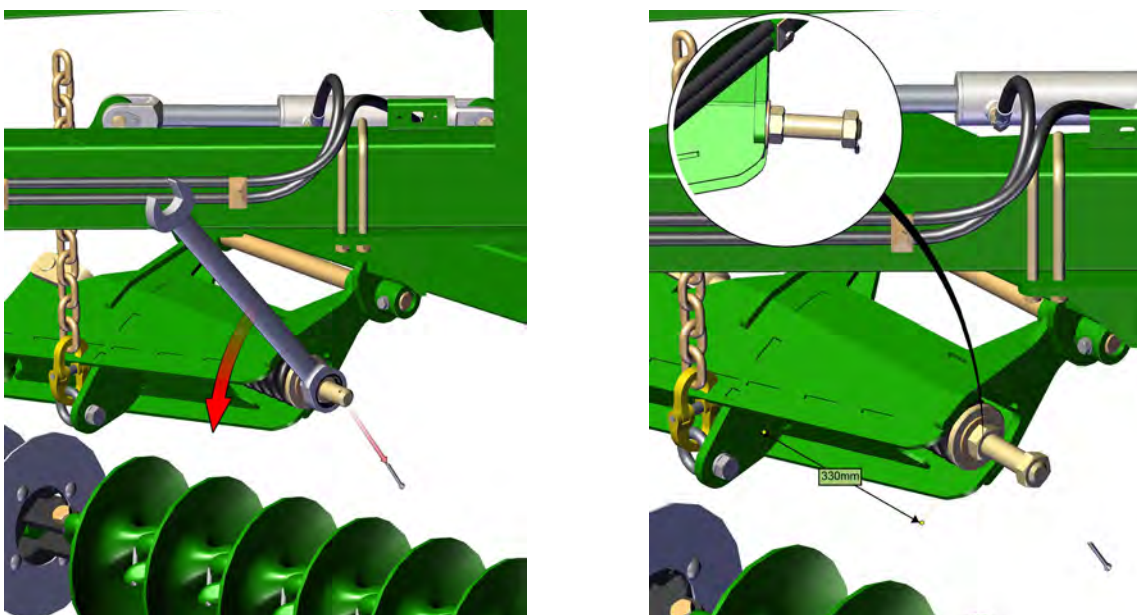

Importance of chain tension

Operational

It is imperative that the correct adjustment be maintained. Only through correct adjustment can a smooth and level finish be achieved in field working.

Loose chains lead to :

- Uneven performance across the width of the machine
- Uneven weed control
- Unsatisfactory incorporation
- Ineffective levelling
- Accelerated or premature chain wear
- Chains failing to engage with transport locators when folded
- Machine damage when folding or unfolding
- Uneven field surface with ridges and furrows being created. The leading 1/3rd of a loose chain is much more aggressive than the trailing 1/3rd and the center. This will mean that middle of the machine's front pair of chains will aggressively move soil outwards. The machine's rear pair of chains, if loose, have their aggressive 1/3rd near the wing extremity. It follows then that as the front discs push soil outwards, the least aggressive portion of the rear chain follows them and does not balance the soil movement. This is exacerbated at the wings, effectively creating a broad ridge about halfway out each wing. It won't be evident in one pass, but is possible if care is not taken over time.

A correctly adjusted machine will not cause this phenomenon.

Settings for correct working height

To adjust the swivel height at the wings, relocate one of the polyurethane spacers either above or below the fixed mounting tube.

Adjustment

1	Loosen chain tension completely
2	Undo 2 x M10 bolts from corresponding spacer set and take the two halves off of the drop leg tube
3	Replace it in the selected position after raising or lowering the drop leg
4	Reinstall the M10 bolts and re-tension the chain

It is possible to install all spacers either above or below the mounting tube giving a maximum of 4" (100mm) of adjustment.

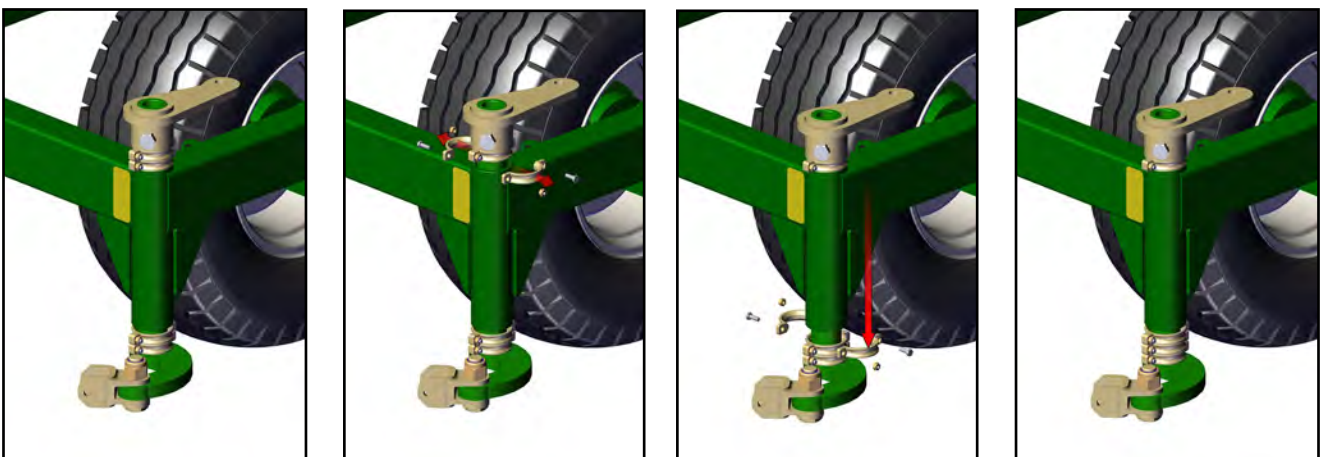



Phone +61 8 8667 2253
Email sales@kellytillage.com
kellytillage.com

Booleroo (Head Office)
684 Kelly Road,
Booleroo Centre SA 5482

Adelaide Office
28 Greenhill Road,
Wayville SA 5034

