



Kelly Engineering

Diamond Chain Harrow

Operating Instruction Manual

60 Model

Prepared By
Kelly Engineering
PO Box 100
Boileroo Centre 5482
South Australia

Ph: 08 86 672 253

Fax: 08 86 672 250

E-mail: office@kellyengineering.com.au

Website: www.kellyengineering.com.au

CAUTION



BE ALERT

SAFETY FIRST

REFER TO SECTION 1 IN THIS MANUAL ON

SAFETY INFORMATION

Read all assembly instructions and study all photographs thoroughly before attempting to assemble the unit.

Please Note:

Left and right is determined by standing behind the machine and looking to the front.



Thank you for choosing a Kelly Engineering product.

We trust the following instruction manual should be clear and easy to follow, however feel free to contact our company for customer support on 08 86 672 253.

Should you have any problems or better still any improvements or modifications that would help to improve our products please contact us.

New parts can be purchased when required by contacting your Local Dealer or Kelly Engineering on

Ph: 08 86 672 253

Fax: 08 86 672 250

E-mail: office@kellyengineering.com.au

Website: www.kellyengineering.com.au

Contents

Section 1: Safety Information	Page 5
- Signal Words	Page 6
- General Operation	Page 6
- Transporting	Page 7
- Hydraulics	Page 7
- Maintenance Inspection Intervals	Page 7
- Safety Signs	Page 8 - 9
- Safety Sign Locations	Page 10
Section 2: Operation	Page 11
- Pre-operation Checklist	Page 12
- Machine Set Up Prior To Operation	Page 12
- Settings for Correct Working Height	Page 13 - 14
- Maintenance and Inspection Intervals	Page 14
- Trouble Shooting	Page 15 - 16
Section 3: Specifications	Page 17
- Operating Speeds	Page 18
- Tyre Pressure	Page 18
- Prickle Chain Specifications	Page 18
- Prickle Chain Lengths	Page 18
- Disc Chain Lengths	Page 18
Section 4: Sequence Valve Adjustments	Page 19
- Sequence Valve Manifold	Page 20
- Sequence Valve Overview	Page 20
- Sequence Valve Manifold Schematic Layout	Page 21
- Trouble Shooting	Page 22
- Unfolding	Page 23 - 24
- Folding	Page 25, 26 - 27
- Technical Advice and Assistance Details	Page 27
Section 5: Transport Delivery	Page 28
- Unloading	Page 29
Section 6: Assembly Instructions	Page 20
- Unpacking	Page 21
- Assembly	Page 32 - 40
- Attaching The Chain	Page 41 - 43
Warranty	Page 44
Warranty Card	Page 45

Section 1: Safety Information

Signal Words	Page 6
General Operation	Page 6
Transporting	Page 7
Hydraulics	Page 7
Maintenance Inspection Intervals	Page 7
Safety Signs	Page 8 - 9
Safety Sign Locations	Page 10

Safety Information

<p>CAUTION</p>  <p>BE ALERT</p>	<p>Watch for this symbol. It identifies potential hazards to health or personal safety.</p> <p>It means:</p> <p>ATTENTION - BE ALERT Your Safety Is Involved</p>
--	--

Signal Words

A signal word - **DANGER**, **WARNING**, or **CAUTION**, is used with the safety alert symbol.

When you see this symbol on your machine or in this manual, be alert to the potential for personal injury or death.



DANGER - Indicates an immediate hazardous situation that, if not avoided, will cause **DEATH OR SERIOUS INJURY**.



WARNING - Indicates a potentially hazardous situation that, if not avoided, could cause **DEATH OR SERIOUS INJURY**.



CAUTION - Indicates a potentially hazardous situation that, if not avoided, may cause a **MINOR INJURY**.

Carefully read all safety points in this manual and on your machine. Keep all safety stickers in good condition and replace ones that have been worn or lost. Replacement signs are available by contacting Kelly Engineering.

General Operation

* Proceed cautiously under overhead powerlines and around power poles, as contact may result in the operator suffering a severe electrical shock.

* Never allow anyone within the immediate area when operating machinery.

* Stand clear when raising or lowering wings.

Safety Information

Transporting

- * Always travel at a safe speed. **NEVER EXCEED 25 Km/H**
- * Ensure safety chain is attached correctly to the towing vehicle.
- * Please refer to your own state laws on the rules of transporting farm machinery on roads.
- * Ensure that chains are engaged in chain guides and supports. Chain should be clear of the ground.
- * It may be necessary to increase the spring tension on the brake assembly for road transport. Castor wheel assembly may oscillate when towed above the recommended towing speed.
- * Be aware of the height, length and width of the machine. Beware of obstacles and overhead powerlines.

Hydraulics

- * **NEVER** remove hydraulic hoses or ends with the machine in transport position. Relieve all hydraulic pressure before disconnecting hydraulic hoses and fittings.
- * Ensure all fittings and hoses are in good condition.
- * Do not search for high pressure hydraulic leaks without hand and face protection. As a leak can penetrate the skin, thereby requiring immediate medical attention.
- * Double check that all is clear before operating hydraulics
- * Maintain proper hydraulic fluid levels and pressure.

Maintenance and Inspection Intervals

- * Re Tension chain regularly.
- * Grease every 25 hours
- * Visual check after the first usage. Check for loose or missing hardware, oil leaks.
- * To prevent injury never lubricate or service chain harrow while it is moving, (folding up or down or in working motion).
- * Unauthorised modifications to the machine may impair the function and/or safety and affect machine life.

Safety Information

Safety Signs

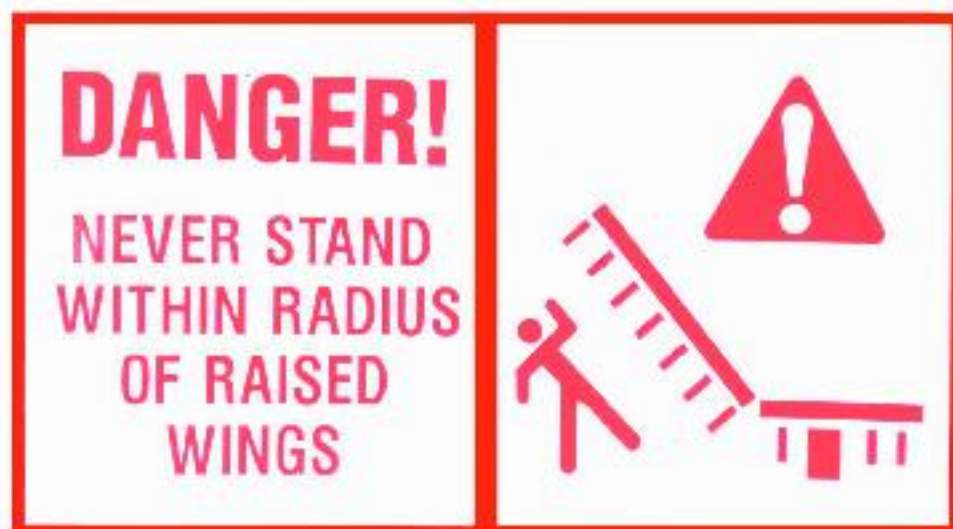
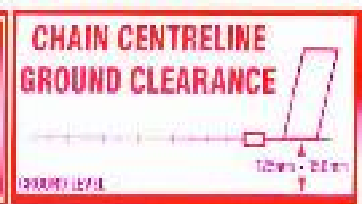
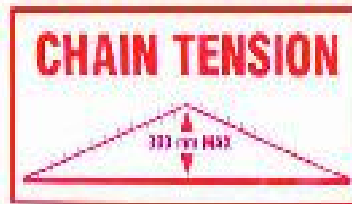

If any Safety Signs are missing please contact Kelly Engineering immediately and do not use the machine.

Safety Information

Safety Signs



If any Safety Signs are missing please contact Kelly Engineering immediately and do not use the machine.

Safety Information

Safety Sign Location

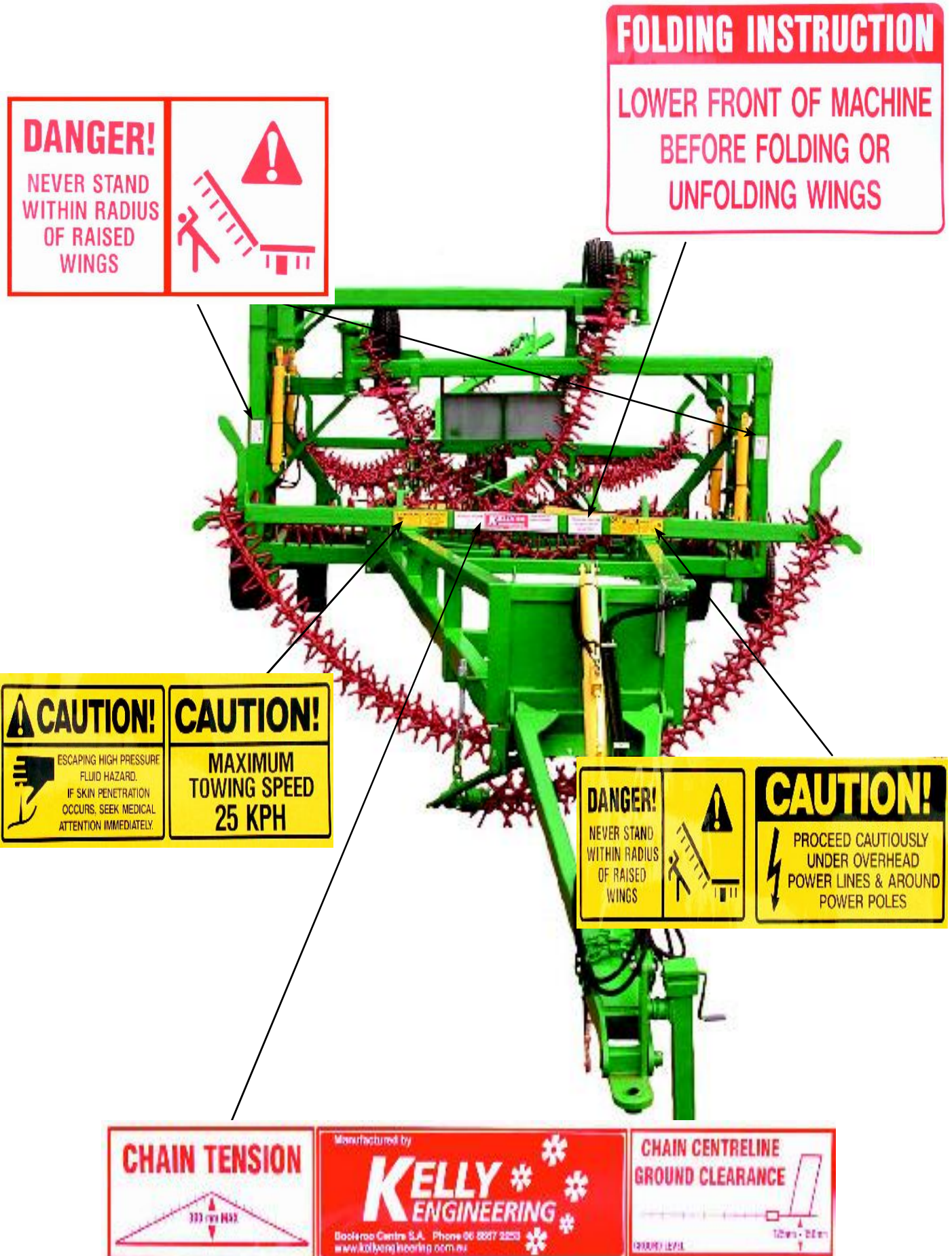

Section 2: Operation

Pre-Operation Checklist	Page 12
Machine Set Up Prior To Operation	Page 12
Settings for Correct Working Height	Page 13 - 14
Maintenance and Inspection Intervals	Page 14
Trouble Shooting	Page 15 -16

Operation

Pre-Operation Checklist

Check:

1	All bolts and nuts are tightened to the correct torque values
2	Split pins are in place
3	Stickers and warning signs are in place
4	Hydraulic fittings are tight
5	Wheel nuts are tight
6	Chains are adjusted so that there is still travel in the adjustors and chains are tight.
7	Fold machine to ensure chains engage Chain Hangers

Machine Set Up Prior To Operating

Unfold machine. Extend lift cylinders until the float pins are centred in their slots. (To allow wing oscillation in uneven terrain).

Rear Tail should be horizontal, this can be adjusted if needed by the thread adjustment on the hydraulic cylinder mount.

Set brake tension on castor wheels to suit ground conditions. Compress spring to 50 to 55 mm.



Operation

Settings for Correct Working Height.

To adjust the bearing height at the wings; Relocate one of the polyurethane spacers either above or below the fixed mounting tube.

1	Loosen Chain tension completely
2	Undo self tapping screw from corresponding spacer then open up the spacer and spring it off of the Drop Leg tube.
3	Replace it in the selected position after raising or lowering the Drop Leg.
4	Re-install the self tapping screw and re tension the chain.



It is important to spend some time setting up the bearing heights to achieve a good result. The Curved Disc chains are more aggressive than previous models and Prickle Chain, it is more critical in achieving a level finish that the bearing heights are set correctly.

It is possible with correct adjustment to achieve a level finish in most situation by manipulating the front and rear heights of each chain.

The leading disc on each chain, if set too low has the capability of pushing up a ridge of soil that following chains may not level out. This can occur at the front of each module, the outer wings at the front of the rear chains and at the front of the machine.

Operation

The trailing disc on each chain, if set too low has the capability of leaving a furrow that may not be filled by other chains. Look for this at the rear of each module chain, on the wings at the rear of the front chains and at the very rear of the machine near the centre line.

There is enough overlap built into the machine to ensure that it is possible to raise the front of all of the chains just clear of the ground and still achieve a full cut.

The optimum setting may vary depending on soil cover. In heavy stubble and unworked ground it is possible to set the bearings low to the ground. In light stubble or loose soil it is best to raise the leading discs so that the chains “feather in” to the soil.

The Main Pull and Rear Tail should both be horizontal, ie parralell to the ground. Fine adjustments should be made using the adjustor chains at each bearing mount plate.

Once the Main Pull is set correctly apply Woah Stop spacers (supplied) to the rod of the Front A Pull cylinder. This sets the drawbar height correctly for that tractor.

Maintenance and Inspection Intervals

Daily	Check Chain Tension
Daily	Visual Check for loose or missing hardware, especially chain/ bearing bolts. Check for oil leaks or damaged hydraulic hoses.
25 hrs	Grease Kingpin Bearings on Tail
25 hrs	Grease Ratchet turnbuckle threads
25 hrs	Wing hinge pins x 8
25 hrs	Rocking Axle bushes (15” wheel models)

Visual check after first usage. Check for loose or missing hardware, oil leaks.

Lubricate threads on the chain tensioners for out of season storage. The machine is designed so that all cylinders are retracted for storage.

Ideally cover chain bearings to prevent ingress of water during storage.



To prevent injury never lubricate or service Chain Harrow while it is moving, (folding up or down or in working motion).

Operation

Trouble Shooting

The majority of Chain Harrow operating problems can be traced to improper adjustment.

This Trouble Shooting section may help you by suggesting a probable cause and a recommended solution.

Symptom	Problem	Solution
Wings Bouncing	Wing tyre pressure too low	Refer to page 18 for Tyre pressure specifications
	Too fast for ground conditions	Reduce speed
Back Tyres Wearing	Castor wheel oscillation	Increase brake spring tension
	Possible King Pin bearing failure	Check and replace bearing
	Wheel bearing failure	Check and repair bearing
	Flat Tyre	Check and Repair
	Excessive brake pad wear	Replace brake pads
	Mud build up between wheels and on frame	Remove Mud
	Stone Jammed Between wheels	Remove Stone
Chain Links Wearing	Chain too loose. Chain loops back when working.	Check length and adjust to correct tension. see page 18
Difficulties in folding of the machine	Low tractor hydraulic pressure	Refer to local dealer
	Sequence valve maladjusted	Refer to section 4 Sequence Valve Adjustment.
Chain Not Rotating	Bearing failure	Check and Replace
	Front chain bearings on machine too low	Lift front bearings using adjustors / front cylinder
	Forgein Material fouling bearings	Clear forgein material from the chains, esp. around bearings.

Operation

Symptom	Problem	Solution
Chains not locating properly on Chain Hangers	Folding chain up on uneven ground	Refold on flat even surface
	Front too high when folding machine	Pull should be at working height when folding machine
	Chain out of adjustment - too slack	Adjust chain tension
Operation leaves central ridge behind machine	Front chain bearings are too low	Raise front bearing / s
Operation leaves central furrow behind machine	Rear Chain bearings are too low	Raise Rear bearings.
Ridging on outside edge of machine	Leading end of corresponding rear chain is too low	Raise corresponding wing bearing.

CAUTION



Never attempt to fold for transport if the chain is clogged with weeds or mud as the extra weight may damage hydraulics or frame.

Section 3: Specifications

Operating Speeds	Page 18
Tyre Pressure	Page 18
Prickle Chain Specifications	Page 18
Prickle Chain Lengths	Page 18
Disc Chain Lengths	Page 18

Specifications

Operating Speeds

Operating Speeds for Normal Conditions	
Chain Type	Speed
Prickle Chain	10 to 16 Km/h
Disc Mulch Chain	10 to 12 Km/h
Transport / Towing on Roads	25 Km/h

Tyre Pressure

		Wing Tyres	Centre Frame Tyres	Castor Wheels
Tyre Size		15.5/80-24	15.5/80-24	31 X 10.50 R15 LT
Ply Rating		12	12	6 Ply Rating
Air Pressure	kPa	240	240	200
	PSI	35	35	30

Chain Harrow Specifications

	Width of Cut	Transport Width	Transport Height	Transport Length
60'	18 m	5 m	3.85 m	20.5 m

Prickle Chain Lengths

60'	LHF	RHF	LHR	RHR
Length	11.6 m	11.6 m	11.6 m	12.9 m
Modules	Front		Back	
Length	2.4 m		2.4 m	

Disc Chain Lengths

60'	LHF	RHF	LHR	RHR
Length	11.6 m	11.6 m	11.6 m	12.9 m
Discs Per Length	67	67	67	75
Modules	Front		Back	
Length	2.4 m		2.4 m	
Disc Per Length	12		12	

Section 4: Sequence Valve Adjustments

Sequence Valve Manifold (pic)	Page 20
Sequence Valve Overview	Page 20
Sequence Valve Manifold Schematic Layout	Page 21
Trouble Shooting	Page 22
Unfolding	Page 23 - 24
Folding	Page 25, 26 -27
Technical Advice and Assistance Detials	Page 27

Sequence Valve Adjustments

Sequence Valve Manifold



Sequence Valve Overview

The Sequencing Valve incorporated in Kelly Engineering Diamond Series Chain Harrows has been designed specifically for our purpose. The Sequence Valve is manufactured by Oilpath in Adelaide, South Australia to a very high standard of accuracy. All components are high quality and very precise.

Like all hydraulic components the main enemy is contamination. Care should be taken at all times to prevent contamination entering the hydraulic circuit.

The Sequence Valve Manifold controls the folding and unfolding of the Chain Harrow.

A single pair of hoses connect the Valve Manifold to the tractor, oil is directed to the first stage of a fold or unfold sequence. When the cylinders reach the end of their stroke and pressure mounts, a valve is triggered allowing oil to flow to the next stage. The valves automatically reset themselves when system pressure allows.

The Valve Manifold incorporates overcentre valves as a safety measure. These valves prevent the tail or wings from falling in the event that one of the tractor hoses should fail.

NB. The Sequence Valve Manifold has a maximum flow capacity of 30 litres per minute.

Sequence Valve Adjustments

Sequence Valve Manifold Schematic Layout

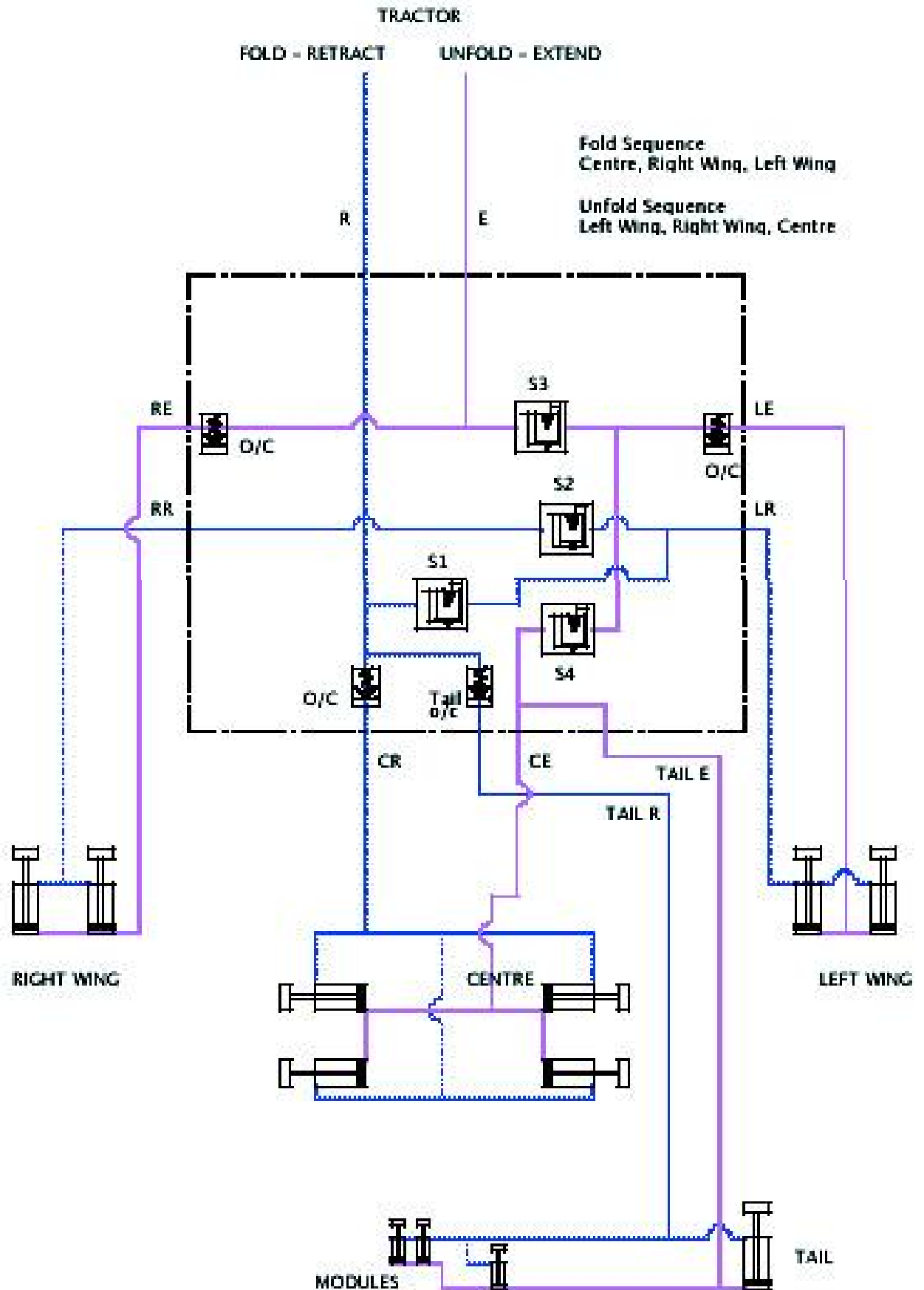

Sequence Valve Adjustments

Trouble Shooting

Problem With:	Symptom	Page
Unfolding	RightWing won't rise from folded position	23
	Right Wing won't rise or won't rise completely but centre tries to open	23
	Right Wing raises vertical but left wing will not raise	23
	Both outer wings raise vertical but centre wont open	24
	Centre Cylinders Extend before outer wings are both straight (Vertical)	24
	No movement at all.	24
	Sequence was working but becomes erratic	24
Folding	Left Hand Outer wing starts to fold first	25
	Centre Cylinders begin to close but Left Outer starts to move before main wings are vertical	25
	Either outer wing starts to move before both main wings are vertical	25
	Both wing stand vertical but the outers wont fold over	26
	Chain misses rear carriers - chain low.	26
	Chain misses rear carriers - chain high.	26
	Sequence was working but becomes erratic.	27
	Un Resolved	Contact Service Agent or Manufacturer



Caution:

Do not remove valve cartridges from Valve Manifold as high pressure oil may be present.

Sequence Valve Adjustments

Unfolding

During Unfolding oil travels directly to the Right Hand Outer Wing cylinders until they are fully extended. Oil then passes over S4 to the Left Hand Outer Wing cylinders. When these are fully extended oil flows past S3 to the Centre cylinders, the tail cylinder and the module cylinders.

RIGHT WING WONT RISE FROM FOLDED POSITION

If the pressure required to raise the right wing is greater than tractor pressure then oil will not flow. This may occur if chain is full of mud or other matter increasing the weight of the chain.

Solution

Clean chains of mud and debris.

RIGHT WING WONT RISE OR WONT RISE COMPLETELY BUT CENTRE TRIES TO OPEN.

If the pressure required to raise the right wing is greater than that set by S4 then oil will flow past S4 to the Left Wing. As the right wing rests on top of the left wing and neither can move then oil is also forced past S3 to the centre cylinders causing them to extend while the outer wings are still folded. As the inner wings unfold and the weight is transferred from the outer wings then the oil will flow to the outer wing cylinders allowing the wings to straighten.

Solution

If Chains are clean then increase the pressure setting on S4. Loosen the locknut with a 17mm wrench then using a 5mm Socket Head wrench turn the centre clock wise. Adjust 1/4 of a turn then test. Repeat if necessary.

RIGHT OUTER WING RAISES BUT LEFT WING WILL NOT RAISE

Oil flows directly from the tractor to the right hand wing to extend the cylinders. If the tractor supply pressure is lower than the pressure set by S4 then no oil can flow to the next stage.

Solution

Check Tractor hydraulic pressure
Lower the pressure setting on S4. Loosen the lock nut using a 17mm spanner then using a 5mm socket head wrench turn the centre anti-clockwise 1/4 turn and test.
Repeat if necessary.

Sequence Valve Adjustments

Unfolding

BOTH OUTER WINGS RAISE BUT CENTRE CYLINDERS WON'T EXTEND

Oil must pass S4 and S3 valves to extend the centre cylinders. If tractor hydraulic pressure is low one or both wings may stand vertical then come to a standstill. As oil is obviously passing S4 to force the Left Hand wing to stand up no adjustment of S4 should be necessary. Oil is not passing S3.

Solution

Check Tractor hydraulic pressure

Lower the pressure setting on S3. Loosen the lock nut using a 17mm spanner then using a 5mm socket head wrench turn the centre anti-clockwise 1/4 turn and test.

Repeat if necessary.

CENTRE CYLINDERS EXTEND BEFORE OUTER WINGS ARE BOTH STRAIGHT (VERTICAL)

See above. Oil must flow past S4 and S3 to extend the Centre Cylinders. Increasing the pressure setting at S4 should be sufficient.

NO MOVEMENT AT ALL

Solution

See first point. Check and if necessary clean chains of mud or debris. Check that hose tips are correctly engaged in tractor breakaway sockets.

Check that any taps or electronic transport locks are open on the tractor.

Check that hydraulic flow on the tractor is not set to very low or off.

Check Tractor Hydraulic Pressure. (Should exceed 2200 psi - 151 Bar)

MACHINE WAS WORKING BUT HAS BECOME ERRATIC

The Sequence Valve Manifold has an oil flow capacity of 30 litres per minute. At this flow the sequence cartridges are able to cope with the flow of oil and operate at their correct settings. If the flow rate is set too high pressure in the Manifold builds up and may unseat the sequence valves prematurely or in an unpredictable manner.

Solution.

Set tractor Hydraulic Remote oil flows to slow.

Restrict oil flow using the Flow Control Valve 'E' (Extend). Loosen the lock nut using a 17mm wrench and then using a 5mm Socket Head Wrench turn the centre screw anti-clockwise (out) until problem ceases.

Sequence Valve Adjustments

Folding

During folding, oil travels directly to the tail and module cylinders and to the centre cylinders. The over-centre valve that protects the main wings from falling is set so as to make the tail cylinder retract before the centre cylinders. When these are all closed oil moves past S1 to the left outer wing. When these cylinders close oil moves past S2 to fold the right outer wing.

LEFT HAND OUTER WING STARTS TO FOLD FIRST

If the pressure required to raise the wings to vertical is greater than the pressure setting on S1 then oil will pass S1 and cause the Left hand outer wing cylinders to retract. This may occur if there is excessive load such as mud or debris or on occasions where the chains may have become blocked and buried.

Solution

Check and clean if necessary any mud or debris from chains. Do not attempt to fold the machine if the chains are buried during a blockage. Clear away the soil from the chains first.

If the chains are clean but problem persists it may be necessary to adjust S1. Loosen lock nut using a 17mm wrench then using a 5 mm socket head wrench increase the pressure setting by screwing the centre clockwise 1/4 turn. Test and repeat if needed.

CENTRE CYLINDERS BEGIN TO CLOSE, RAISING THE WINGS BUT LEFT HAND OUTER COMMENCES TO FOLD BEFORE BOTH WINGS ARE VERTICAL

As above, the centre cylinders should be closed before any oil passes S1 to the left outer wing cylinders.

Solution

Adjust S1. Loosen lock nut using a 17mm wrench then using a 5 mm socket head wrench increase the pressure setting by screwing the centre clockwise 1/4 turn. Test and repeat if needed.

EITHER OUTER WING BEGINS TO FOLD BEFORE BOTH CENTRE WINGS ARE VERTICAL

The centre cylinders should be closed before any oil passes S1 to the left outer wing cylinders or S2 to the right hand outer wing cylinders. For either left or right the oil must first pass over S1 therefore adjustments to S1 as above should cure the problem.

Sequence Valve Adjustments

Folding

BOTH WINGS STAND VERTICAL BUT THE OUTERS WONT FOLD OVER

Oil flows directly from tractor to Centre Retract when folding. If tractor hydraulic pressure is lower than the pressure setting on S1 or S2 then the outer wings may not fold.

Solution

Check tractor hydraulic pressure. It should be at least 2200 psi - 151 Bar.

Lower pressure setting of S4 to fold Left hand wing and S3 to fold right hand wing.

Loosen the lock nut on S4 using a 17mm spanner then using a 5mm socket head wrench turn the centre anti-clockwise 1/4 turn. Test and repeat if necessary.

If Right wing doesn't move repeat procedure on S3 valve.

CHAIN MISSES REAR CARRIERS – TOO LOW.

The tail section of the machine is hinged at the rear of the main frame. If the transport cylinder at the front of the machine is raised, the rear chains are loosened when the wings are raised.

Solution

Leave front of the machine in working position until wings are folded and chains locate in their hangers.

CHAIN MISSES REAR CARRIERS – TOO HIGH

If folding on uneven ground it may be possible for the tail section to be below the level of the machine. This will cause the rear chains to tighten and possibly swing above the transport hangers when folding.

Solution

Move to level ground before folding.

Slightly raise the front of the machine to compensate.

Sequence Valve Adjustments

Folding

SEQUENCE WAS WORKING FINE BUT HAS BECOME ERRATIC

The Sequence Valve Manifold has an oil flow capacity of 30 litres per minute. At this flow the sequence cartridges are able to cope with the flow of oil and operate at their correct settings. If the flow rate is set too high pressure in the Manifold builds up and may unseat the sequence valves prematurely or in an unpredictable manner.

Solution.

Set tractor Hydraulic Remote oil flows to slow.

Restrict oil flow using the Flow Control Valve 'E' (Extend).

Loosen the lock nut using a 17mm wrench and then using a 5mm Socket Head Wrench turn the centre screw anticlockwise (out) until problem ceases.

NB. Always re-tighten lock nuts after making adjustments.

IF THESE ADJUSTMENTS DO NOT SOLVE THE PROBLEM

Contact your service Agent for assistance. There may be a fault with one of the cartridges. The Valve Manifolds are tested at factory and again prior to shipping. The assembling Agent will also have ensured the correct operation prior to delivery. Very rarely but occasionally valves do fail. The usual cause is ingress of contaminant.

You may also contact Kelly Engineering for technical advice and assistance.
International : 61 8 8667 2253.
From within Australia 08 8667 2253

Section 5: Transport Delivery

Unloading

Page 29

Transport Delivery

Unloading



CAUTION

Only unload Chain Harrow Frames on to a flat firm surface for stability. Ensure that the centre sections can not topple over causing injury or death.

Please Note:

We recommend that a crane be available for unloading and assembly of Chain Harrow modules.

1. Lift frames according to your equipment as shown here.

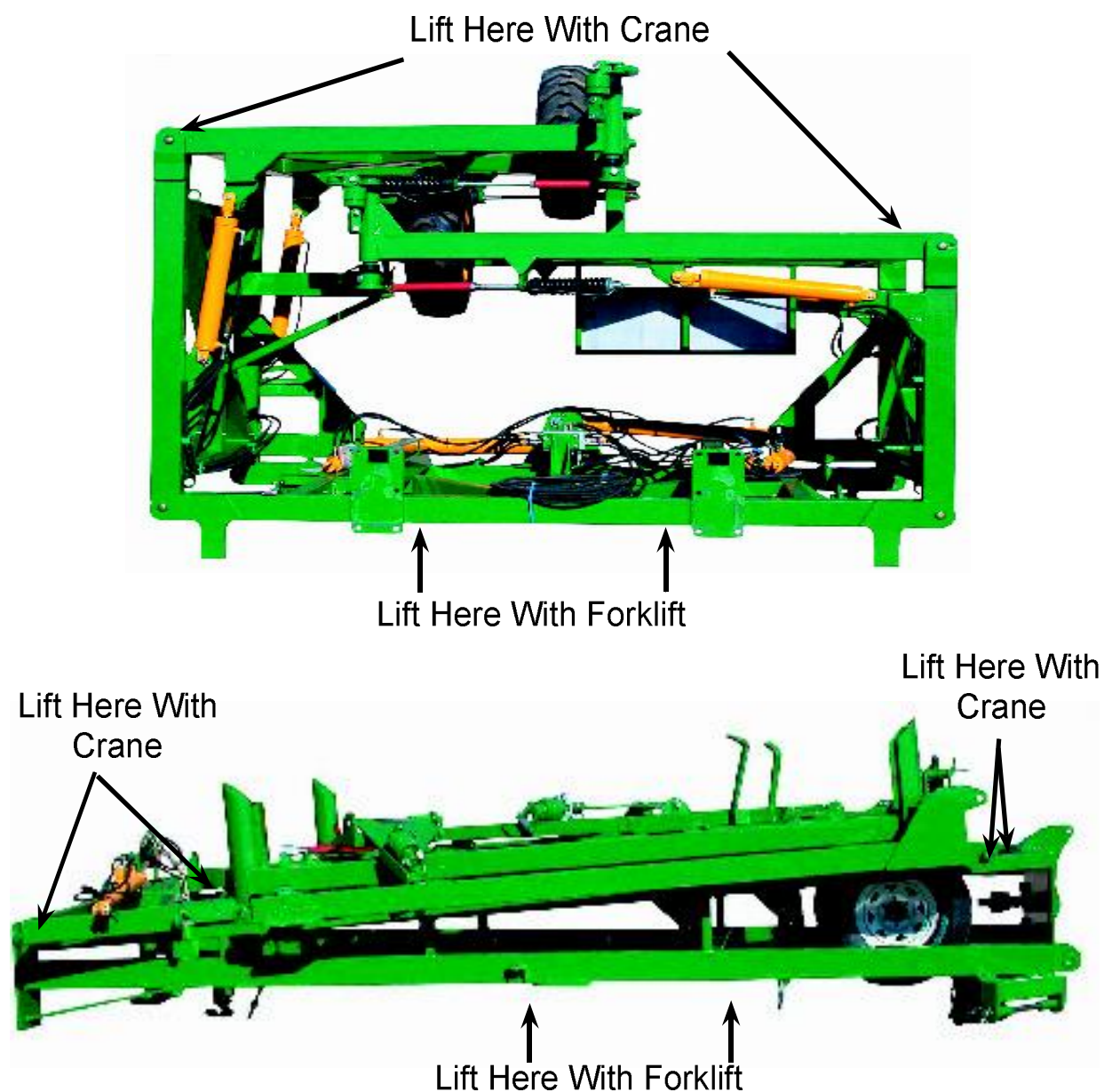

Section 6: Assembly Instructions

Unpacking	Page 31
Assembly	Page 32 - 40
Attaching The Chain	Page 41 - 43



Caution

Do not make any adjustments to sequence valve until fully assembled with chain attached and correctly tensioned.

Only in this state are correct operating pressures achieved.

Unpacking

Unpacking



CAUTION

Assembly should only commence on a large flat firm surface that is free from over head power lines and obstructions.

1. Unpack all components.

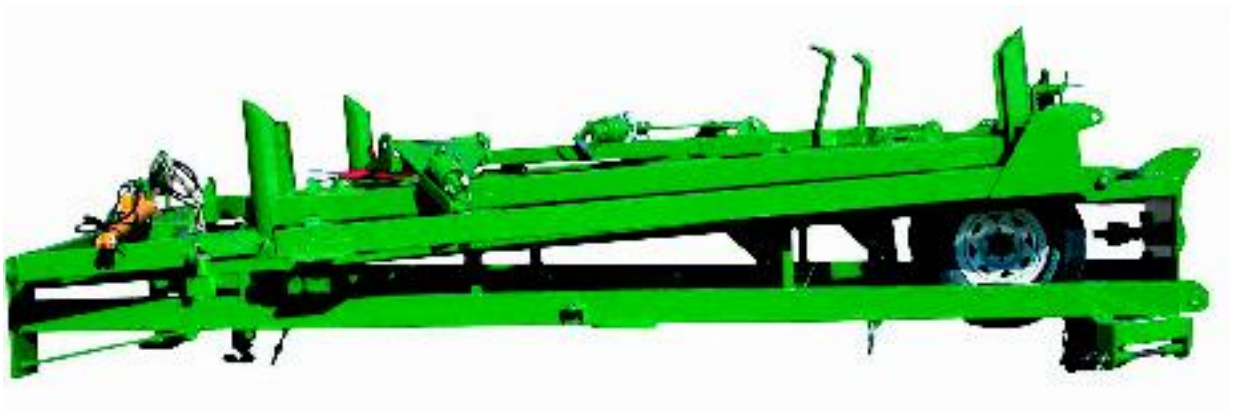
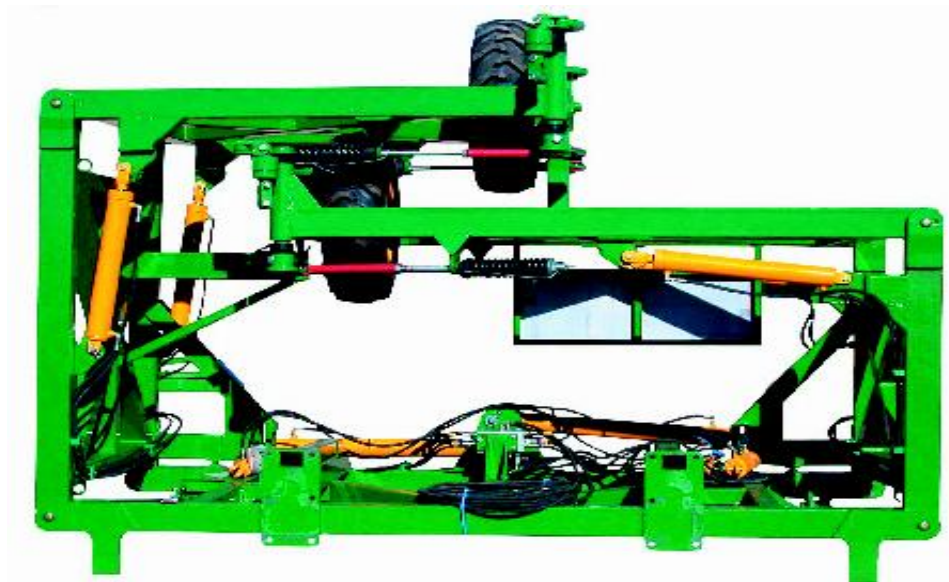

CAUTION

When unpacking machine components use caution to ensure sections do not move suddenly when straps are released. Keep hands, arms and legs clear when straps are released.

Assembly Instructions

Assembly

2. Attach Tow Hitch assembly to Front A Frame using 38mm x 940mm pin and M10 x 65mm bolt and nyloc nut.
Torque nut to 44 Nm.

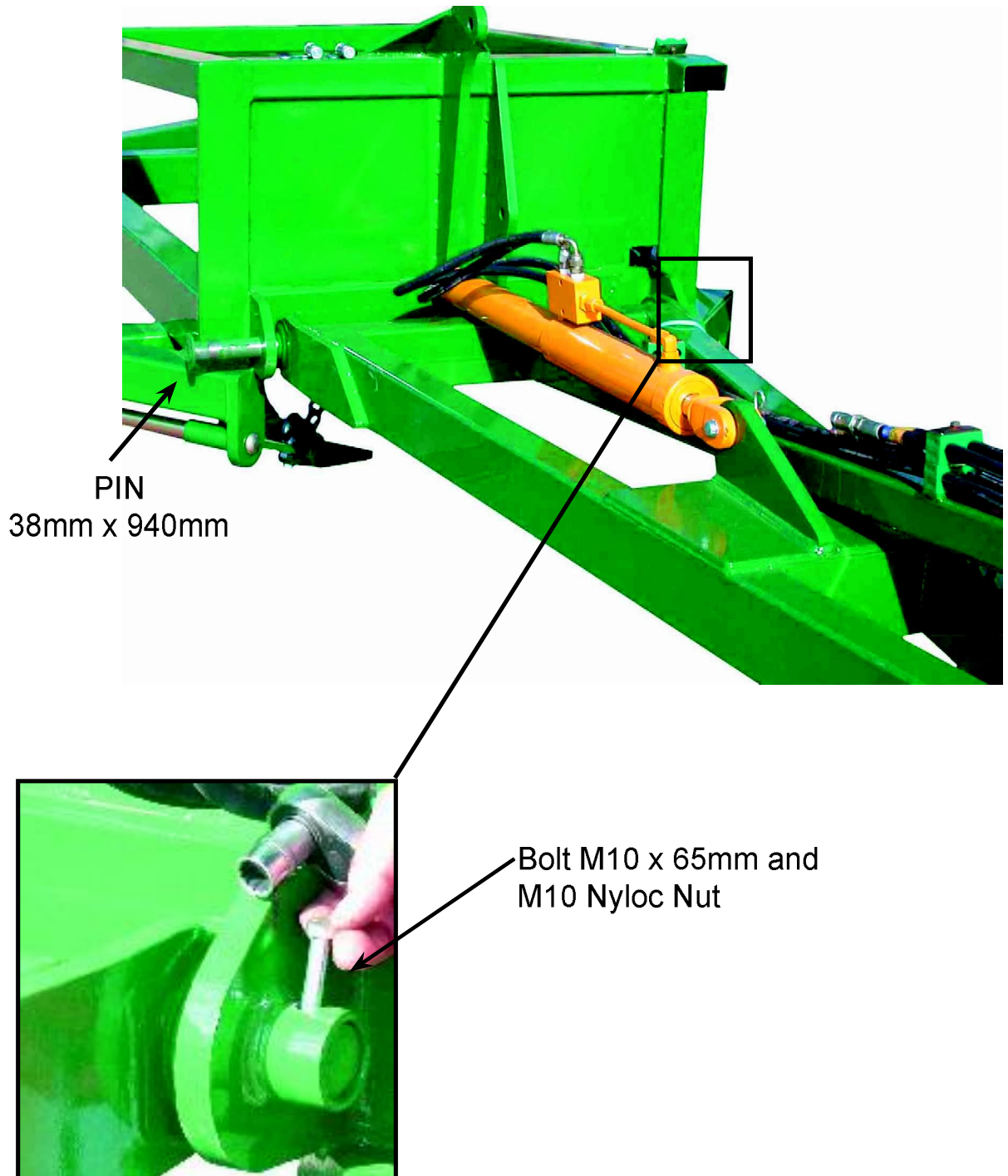

Assembly Instructions

- Secure cylinder with lockout valve uppermost using 1" Pin and R Clip.

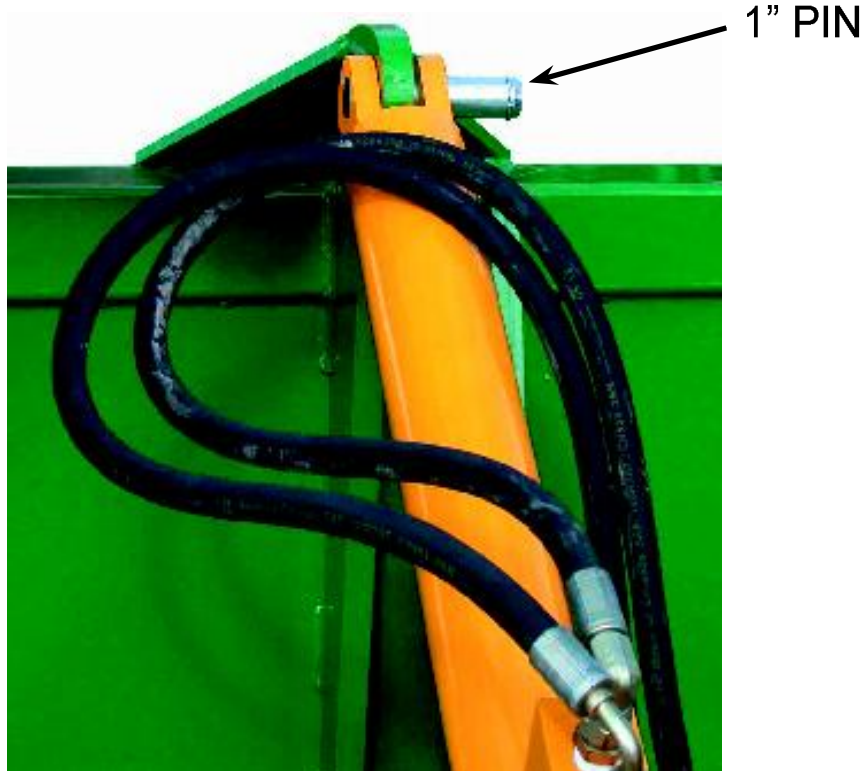

- Attach Parallelogram Arm to Mount Plate on A Pull with a 1" Pin and R Clip.
N.B RCD Clamp Mount to Front

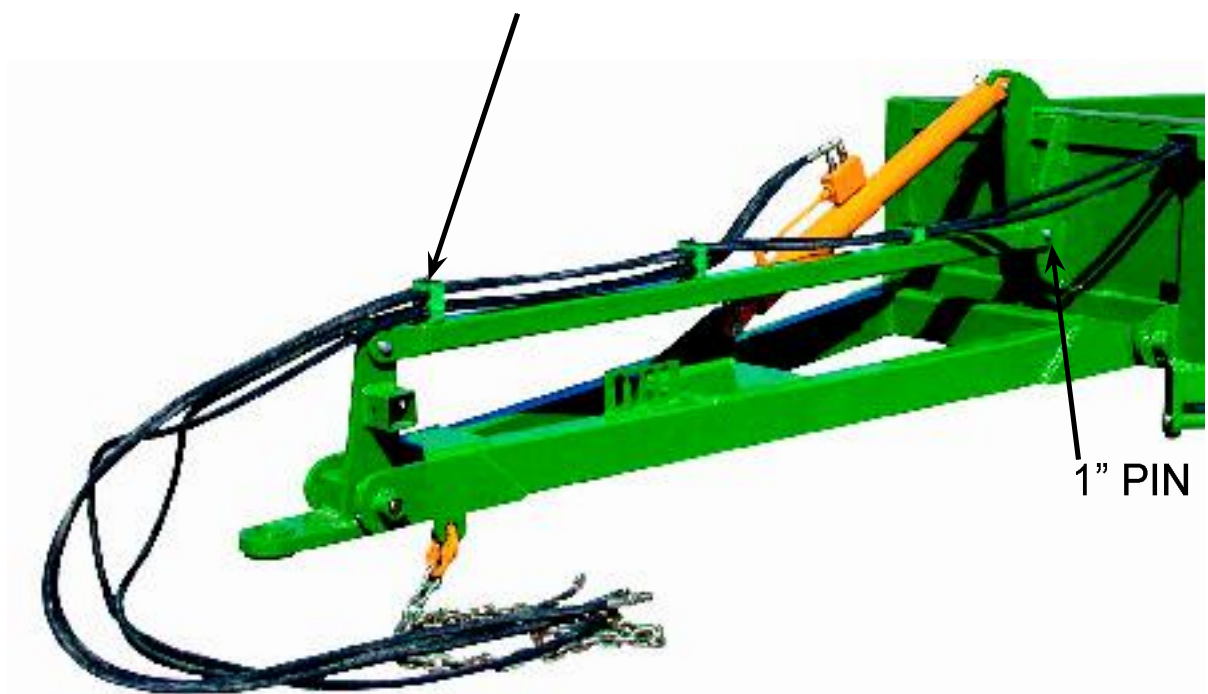

Assembly Instructions

5. Attach Front A Frame to Centre Frame using 12 M24x75mm Bolts and M24 Nyloc Nuts. Torque nuts to 370 Nm. Support Front A Frame with suitable blocks to align bolt holes.



CAUTION

When bolts are secure hitch tractor to the Draw bar for stability (do this to stabilise the Centre Frame before continuing).

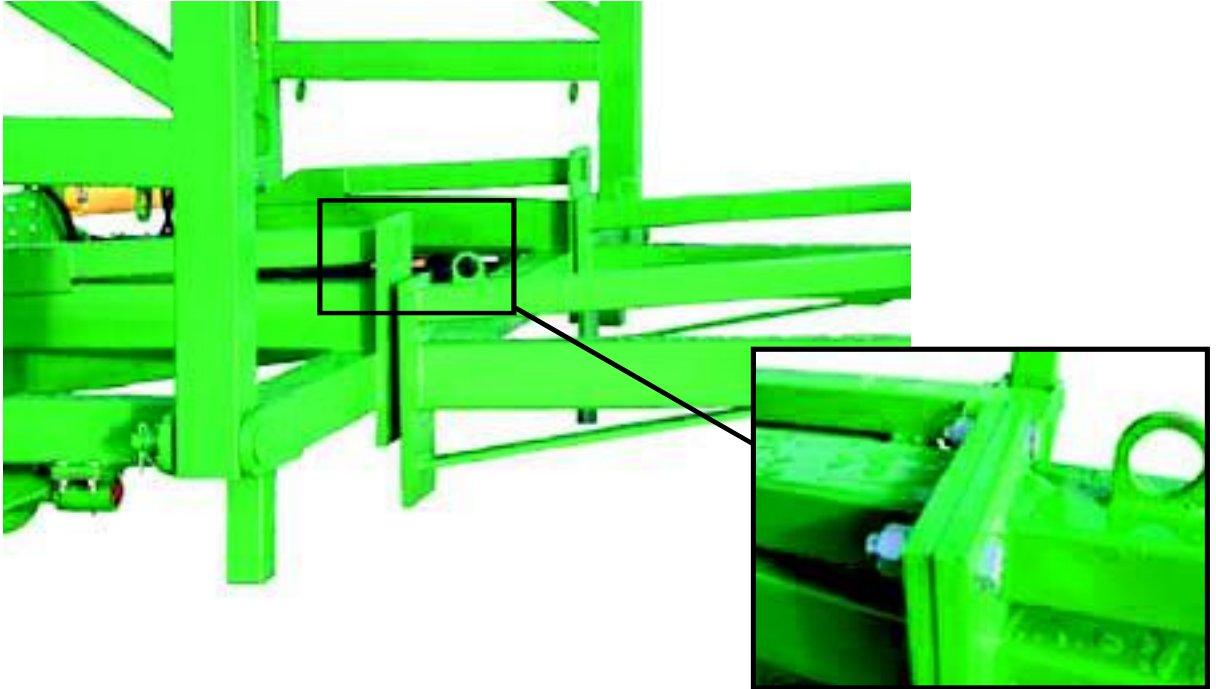

6. Raise Front Module using appropriate lifting equipment and attach to Front A Frame using 8 M16 x 65mm Bolts and Nyloc Nuts. Torque nuts to 190 Nm. Attach 2 1/2" x 6" Cylinder to Module using 1" Pins and R Clips provided.



Assembly Instructions

7. Uncoil and thread one pair of hydraulic hoses (PH01 and PH01) through the left hand upper frame member of front A Fame and secure with clamps. (For ease of threading use a draw wire).



8. Plug breakaways into hydraulic remotes on tractor and extend Cylinders to unfold Centre Frame. The operation is controlled by the sequencing valve. Hold the tractor remotes open until the Centre Frame Cylinders centralise in their slots. The 5 sections should now be laying flat on the ground.



9. Raise Centre Frame section with suitable lifting equipment and attach wheels to hubs. Torque wheel nuts to 270 Nm.



Assembly Instructions

10. Identify Rear Module and place in approximate position behind Centre Frame.

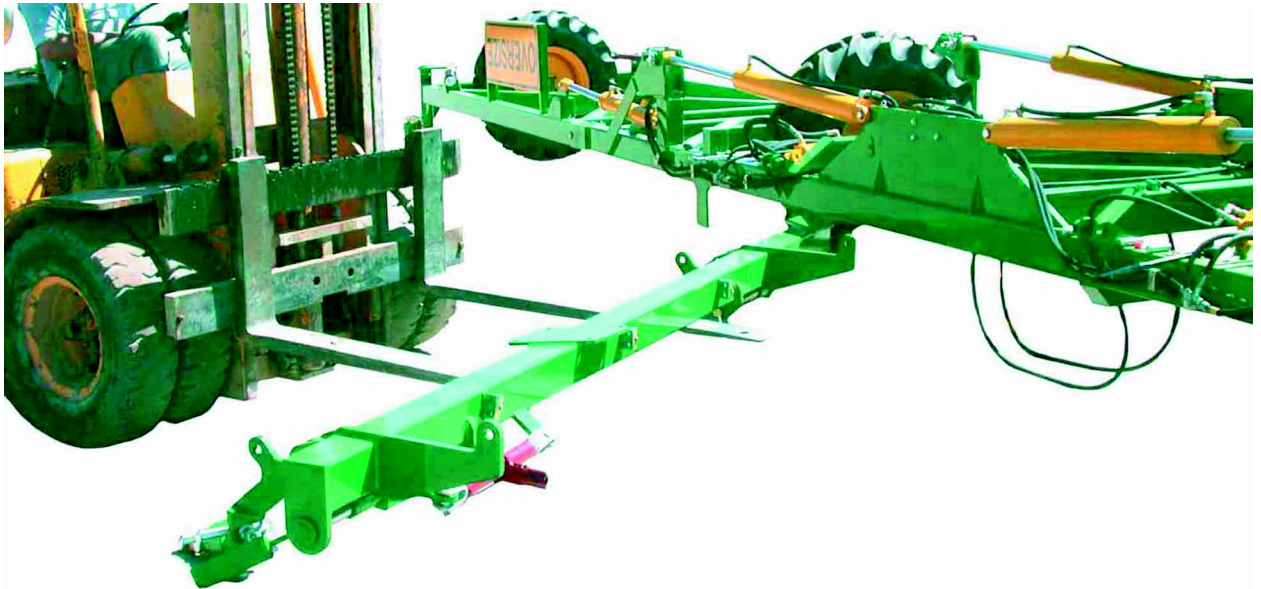

11. Attach Rear A Frame to mounting points on Centre Frame using 2 35mm x 140mm Pins and secure Pins with M10 x 65 Bolts and Nyloc Nuts. Torque nuts to 44 Nm.

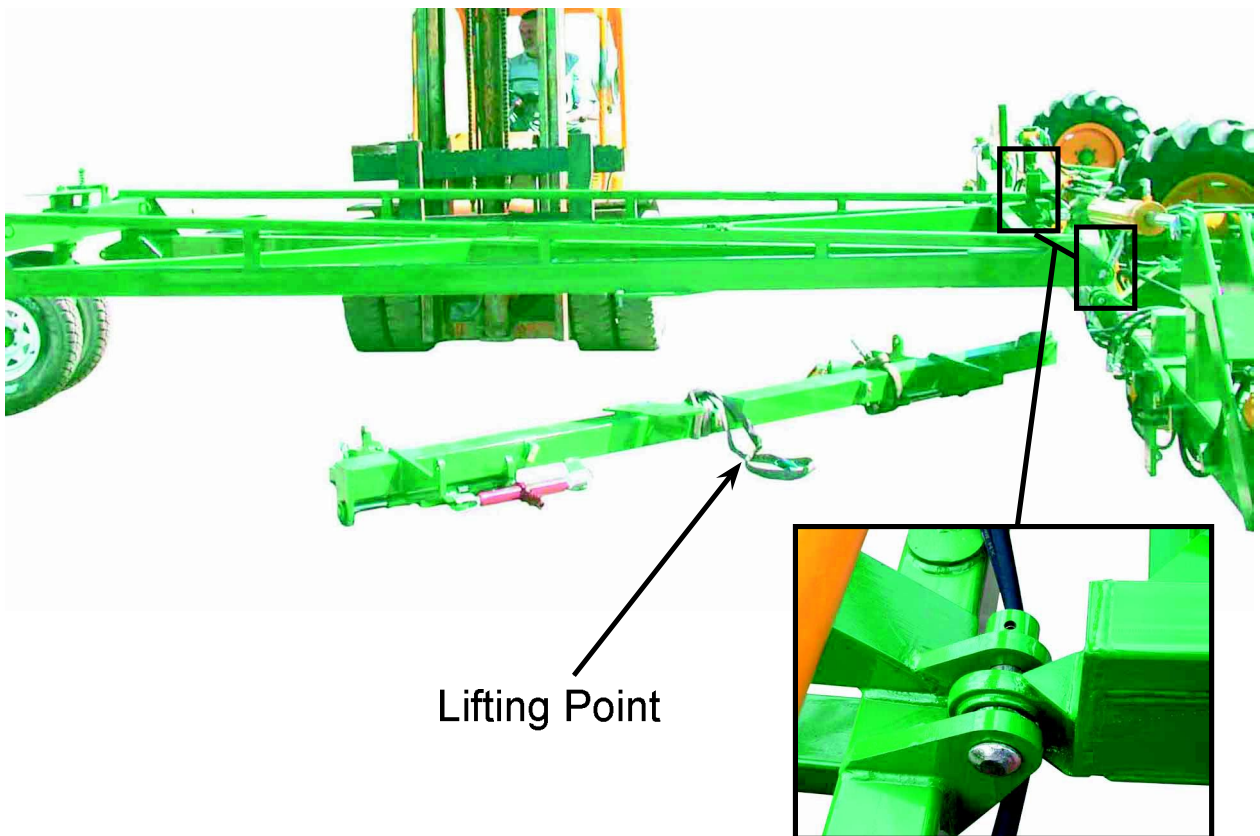

12. Unstrap 4" x 8" Cylinder and 2 of 6" x 2 1/2" Cylinders and Hoses from Centre Frame.

Assembly Instructions

13. Raise Rear Module using appropriate lifting equipment and attach to Rear A Frame using 8 M16 x 50mm Bolts and Nyloc Nuts. Torque nuts to 190 Nm. Attach 2 1/2" x 6" Cylinders to Module using 1" Pins and R Clips provided.

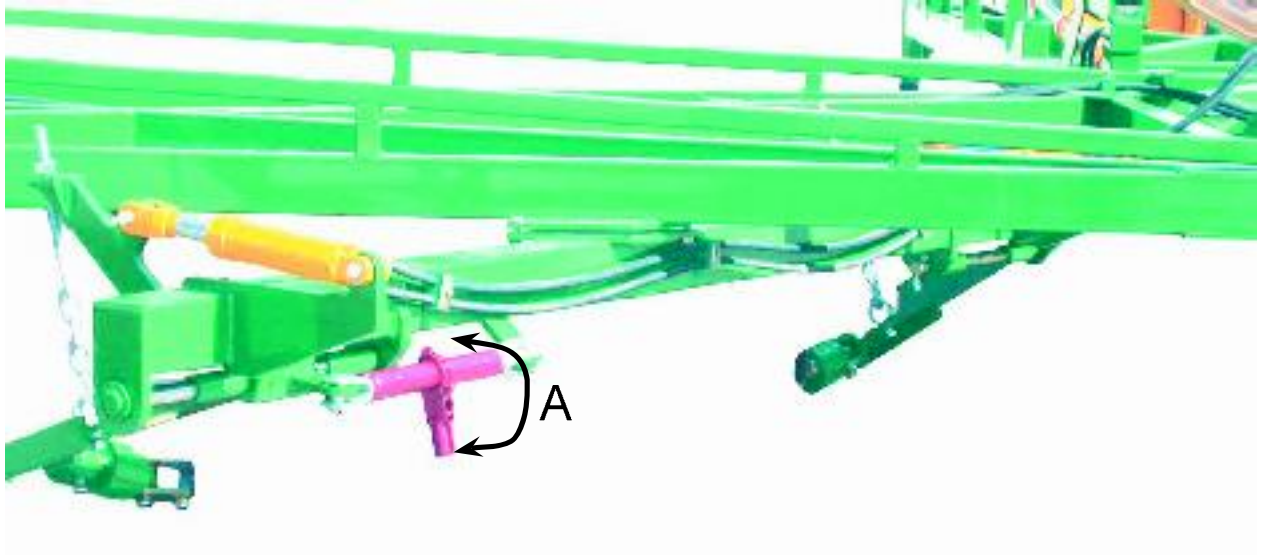

- A. Attach Ratchet Top Link to Module so that the Ratchet holds the threads extended with handle at rest vertically.
14. Using suitable lifting equipment lift Rear Tail with Cylinder Adjusting Screw uppermost and on the left into position and attach to Rear A Frame using 2 35mmx140mm Pins and secure Pins with M10 x 65mm Bolts and Nyloc Nuts. Torque nuts to 44NM. Attach 4"x 8" Cylinder to Rear Cylinder Mount and Cylinder Adjusting Screw using 1" Pins and R Clips provided. Secure hoses along Rear A frame using clamps.



NB. Set Adjusting Screw so that Rear Tail is in line with or slightly above the line of the Rear A Frame

Assembly Instructions

15.

- (A) Attach Front Chain Carrier to Front A Frame by using 4 M16x232x127 U Bolts, M16 Nyloc Nuts and PC 84.2 Tie Plates 150x50x10. Torque nuts to 73 Nm.
- (B) Attach Rear Chain Carrier Pedestals to Rear A Frame by using 4 M16x80x77 U Bolts and M16 Nyloc Nuts. Torque nuts to 73 Nm.
- (C) Attach Rear Chain Carrier to Pedestals by using 4 M16x155x127 U Bolts and M16 Nyloc Nuts. Torque nuts to 73Nm.

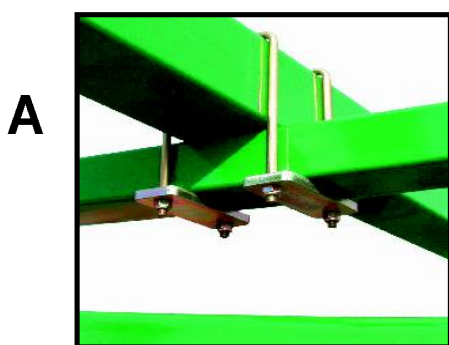

Front

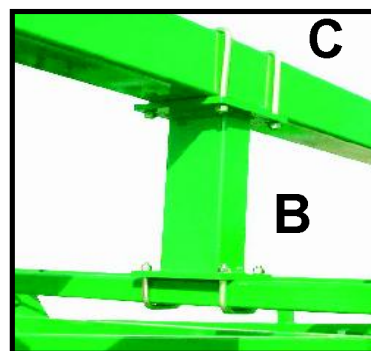

Rear

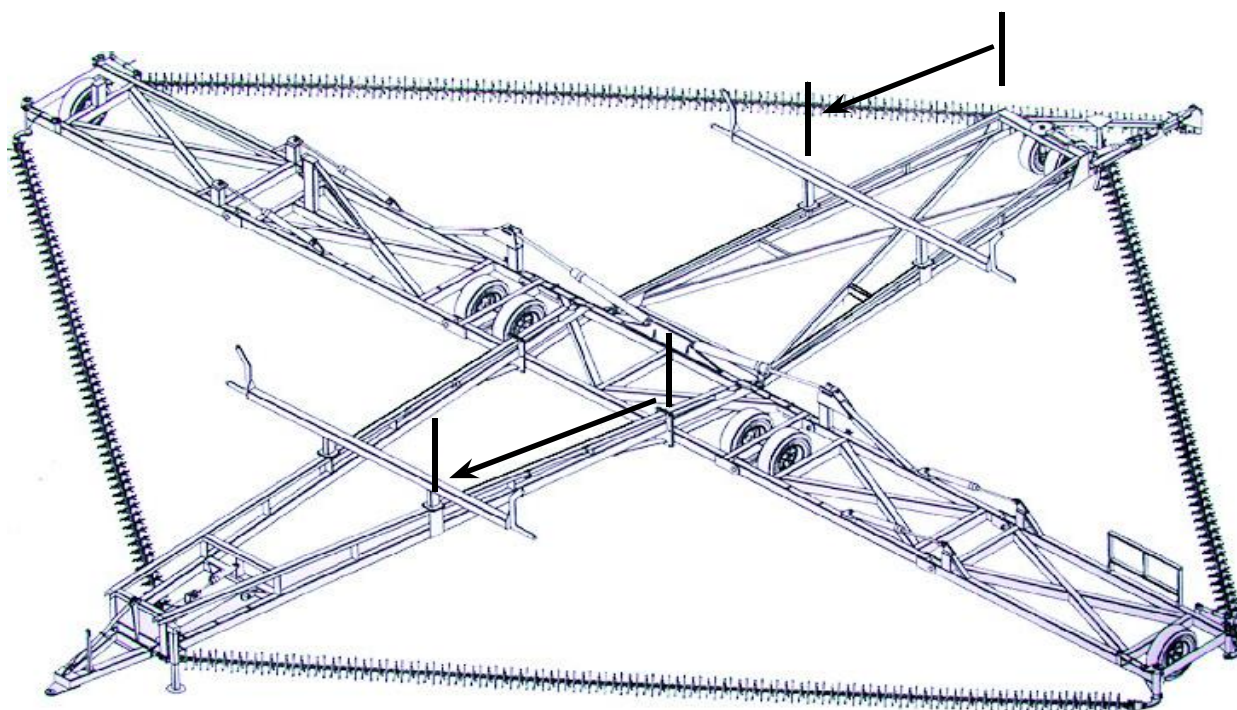

- 15.1. To measure distances for Front Chain Hanger measure from joining plates forward along Front A Frame.
- 15.2. To measure distances for Rear Chain Hanger measure from inside Rear of Rear A Frame forward.

	Front Hanger LHS	Front Hanger RHS	Rear Hanger LHS	Rear Hanger RHS
Model 60'	3950 mm	3950 mm	2300 mm	2300 mm

Please Note: These measurements are only a guide

Assembly Instructions

16. Attach the Front and Rear 'M' Frames as per diagrams. These support the chain when folded for transport.

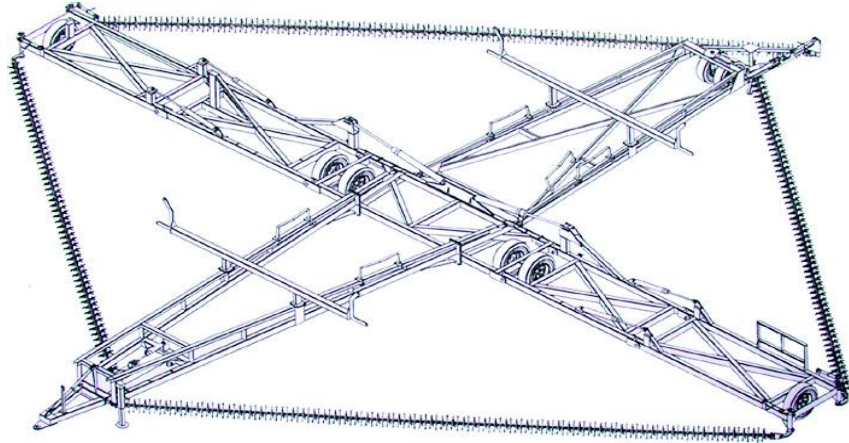

- 16.1. To measure distances for Front 'M' Frames, measure 2500mm from end of joining plates forward to the middle of the 'M' Frame.

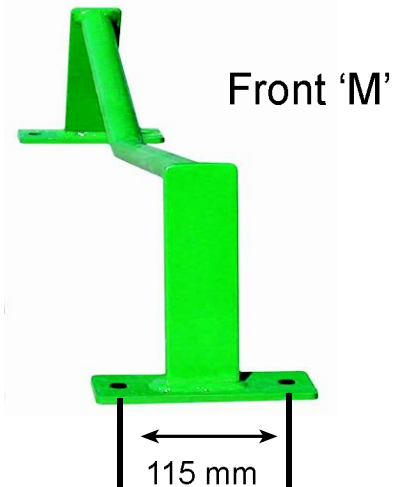
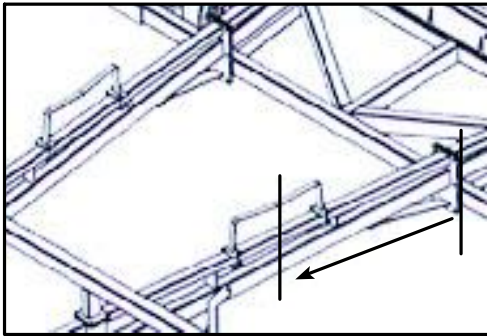

- 16.2. To measure distances for Rear 'M' Frames, measure from start of Rear A Frame Mounting Points rearwards to the middle of the 'M' Frame.

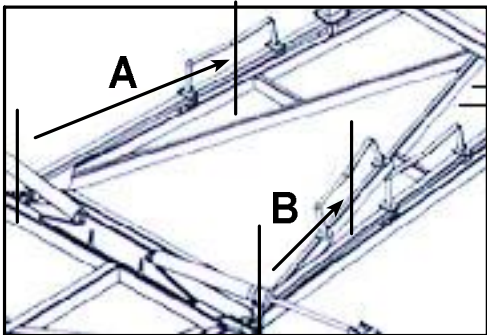

A. 2500 mm

B. 2230 mm

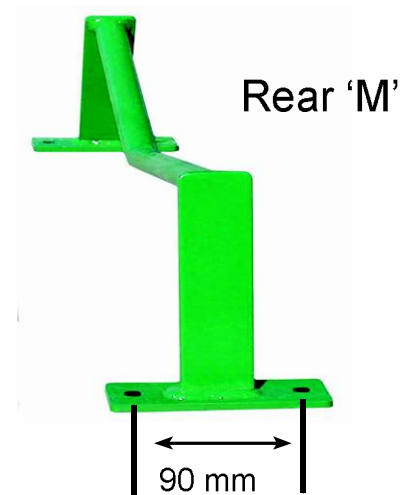

NB. Leave U Bolts on 'M's loose, make final adjustment as the machine is folded for the first time with chains attached. Then Torque U Bolts to 30 Nm.

Assembly Instructions

17. Attach Bearing Assemblies to drop legs using M20x110 Bolts and M20 Nyloc Nuts. Torque nuts to 528 Nm.
Attach Tie Plates (PC82.3) to Bearing Assemblies using M20 x 110 Bolts and M20 Nyloc Nuts. Torque nuts to 528 Nm.
Ensure Bearing Assembly is attached to the machine so that the **SHAFT FACES REARWARDS**.
This reduces the chance of dirt damaging the seals.

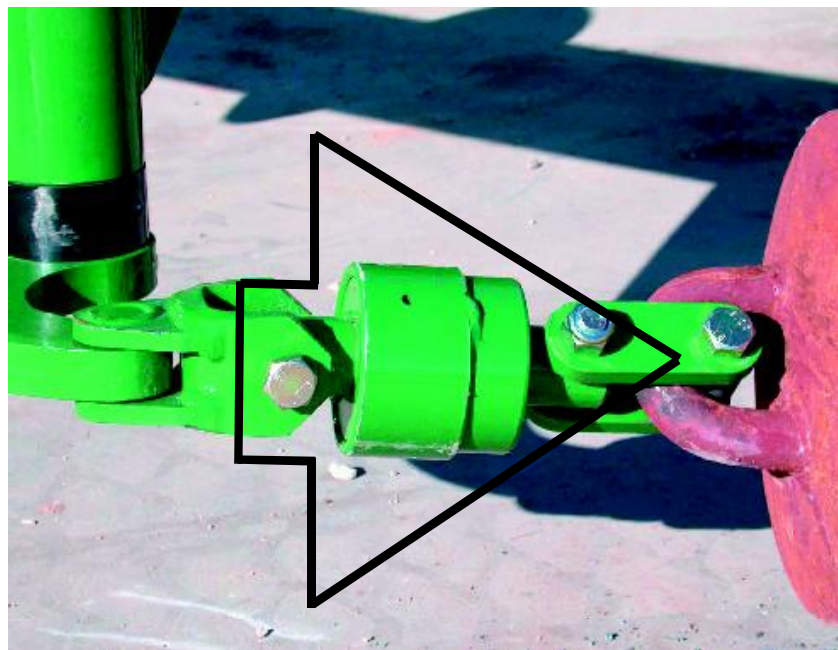
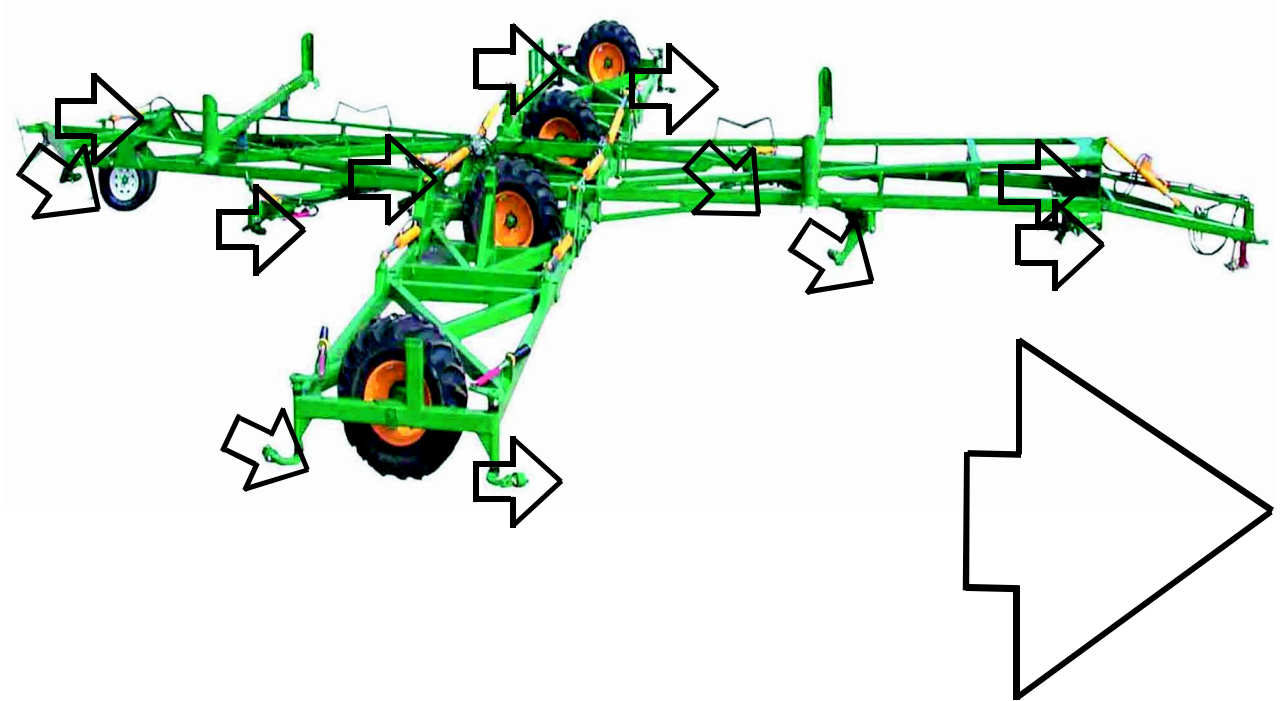

Assembly Instructions

Attaching The Chain



CAUTION

Use appropriate lifting methods to avoid back strain.
Chain is very heavy and awkward to handle

18. Using a forklift or similar to handle the bundles of Disc or Prickle Chain.
Identify the 4 chains LHF (left hand front), RHF (right hand front), LHR (left hand rear), RHR (right hand rear) and place them around the machine as shown. (Refer to page 18 for specifications).
Position bundles of chain at front and rear and attach, then pull towards the wings.

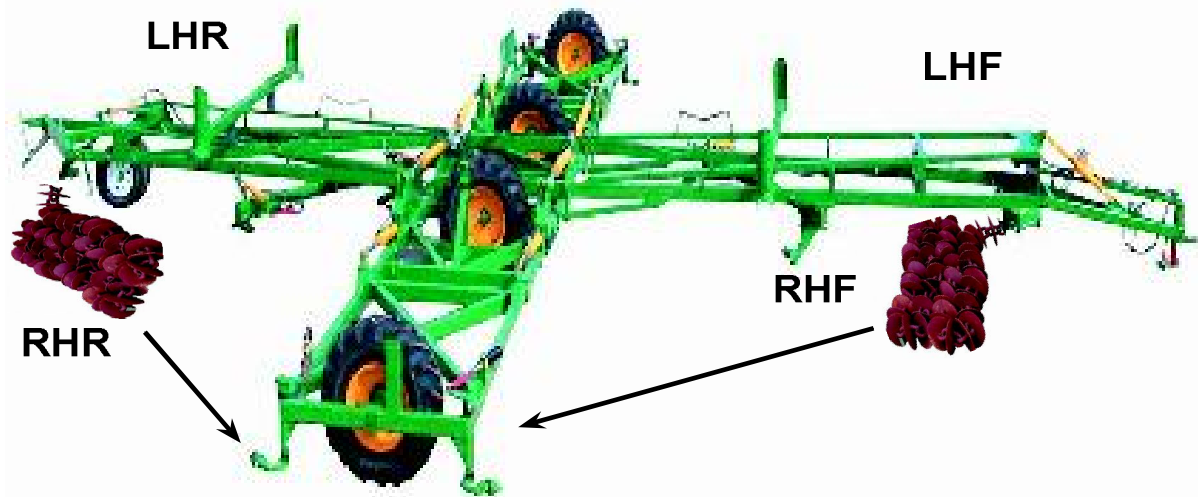

19. Attach the chain with the marked (tag) end to the front mounting point for each chain. Use appropriate lifting methods to avoid back strain.
Attach chain to bearing assembly's using M20x110 bolts, M20 Nyloc Nuts, Bush and Tie Plates PC 82.3.
Torque nuts to 528 Nm.

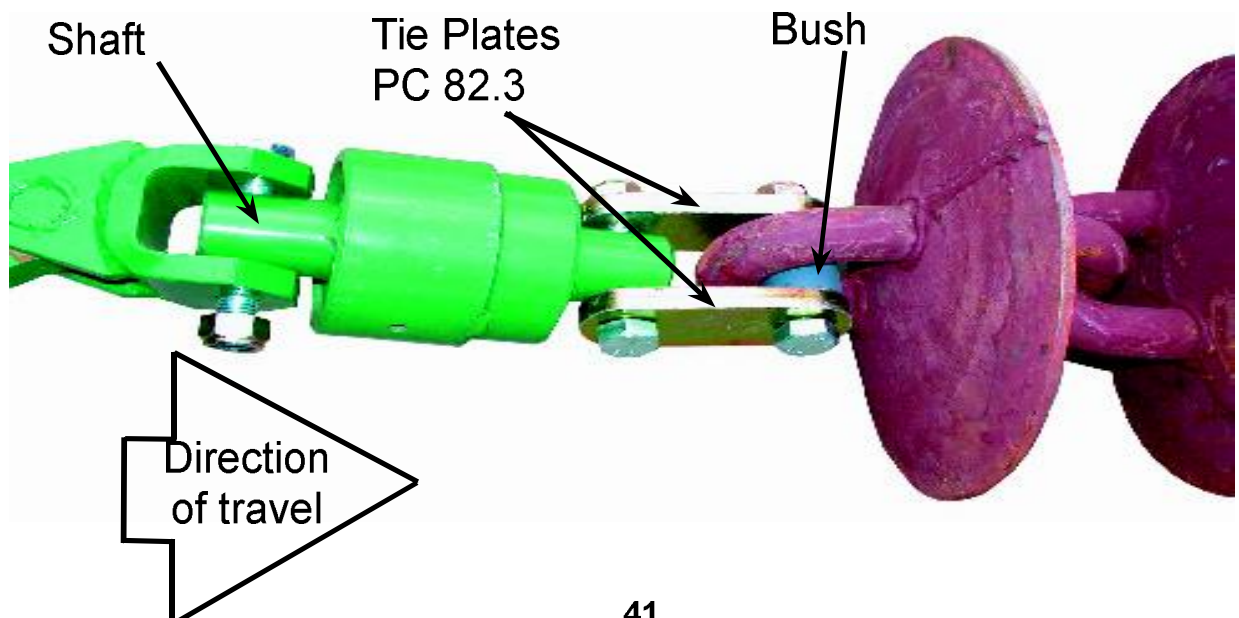

Assembly Instructions

20. The centre of the Bearing Assembly's should be positioned off the ground (when in working position), by using the approximate measurements on the chart below.

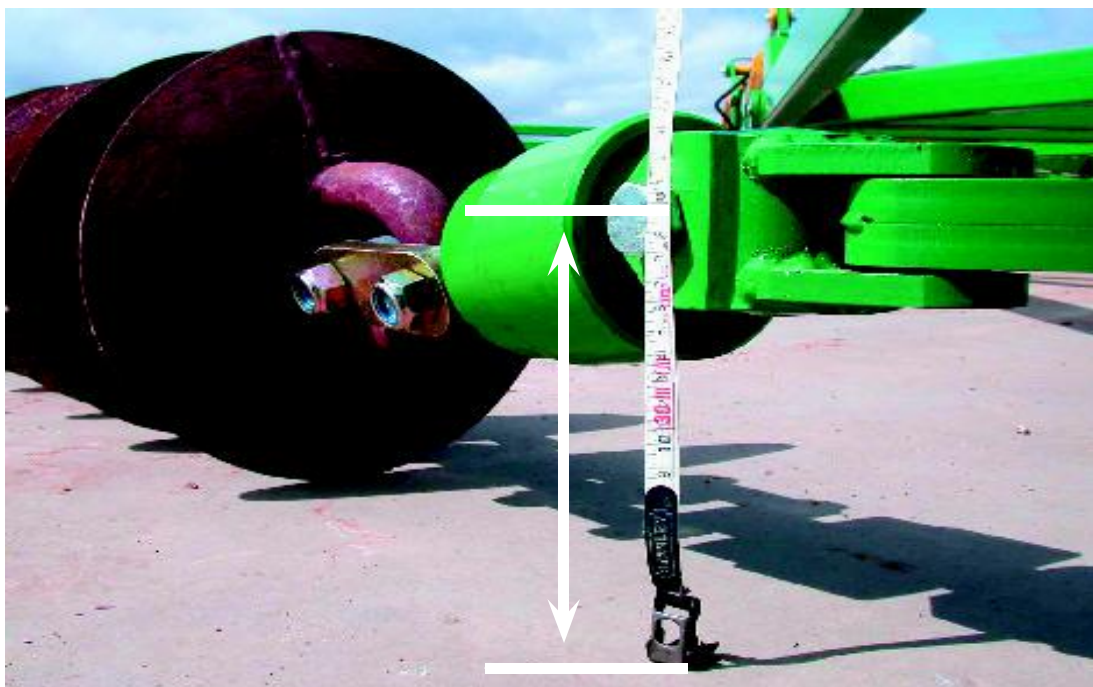

Front Bearing's on all chains (Front)	180mm - 200mm
Rear Bearing's on all chains (Rear)	130mm - 160mm
Front Module Bearing's (FMB)	200mm - 300mm
Rear Module Bearing's (RMB)	130mm - 160mm

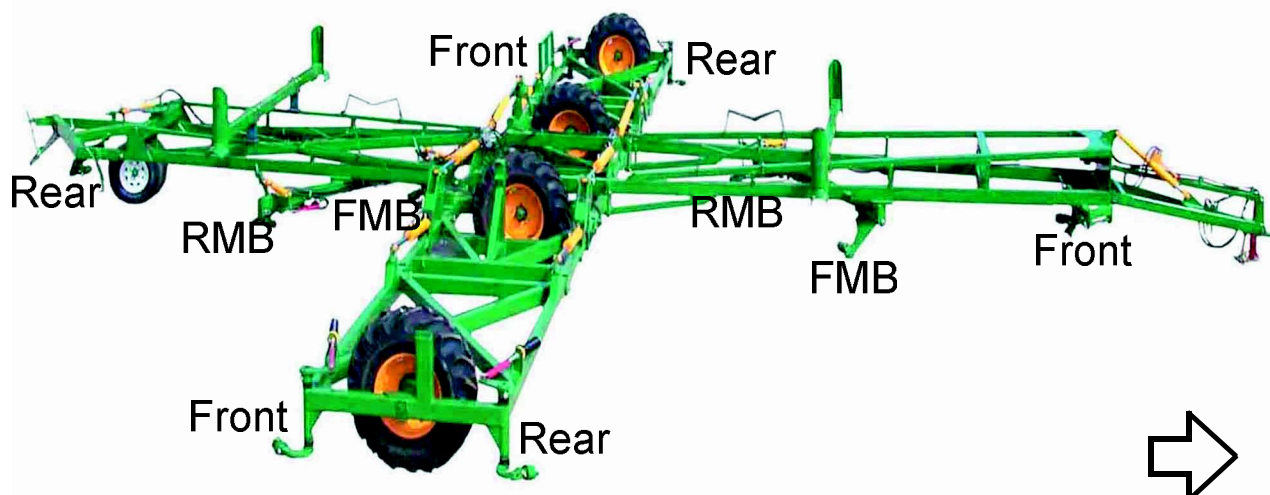

Assembly Instructions

21. Using supplied wrench adjust chain tensioners on the wings to compress the coil spring approx. 30mm.
Chain tension should be such that the chains “belly” a maximum of 300mm when working.
During the initial wear period chain length will increase by 100-150mm. A link must be removed before the adjustor reaches it full travel.

NB. Use oxy cutting equipment to remove link.

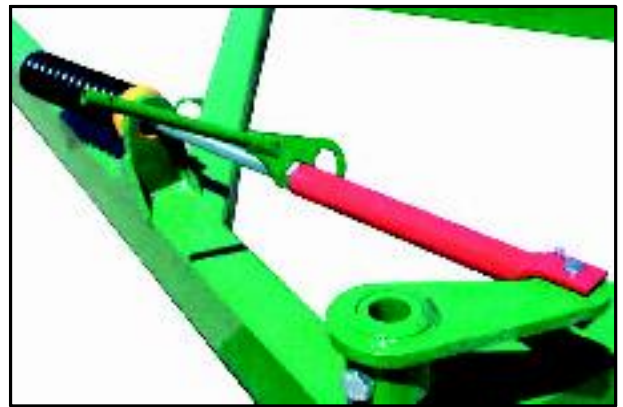

22. Set brake tension on castor wheels to suit ground conditions.
Compress spring to 50 -55mm

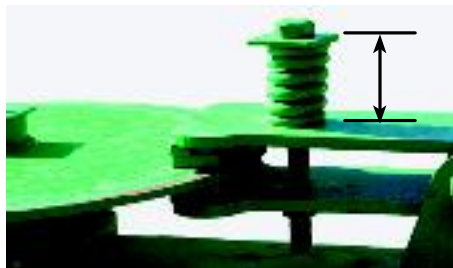

Caution

Set Tractor Hydraulic flow to slow.
Otherwise hydraulic flow and pressure will disrupt sequence.

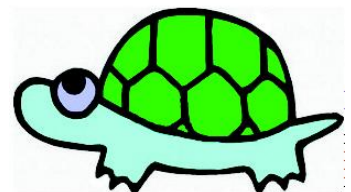

Caution

Do not make any adjustments to sequence valve until fully assembled with chain attached and correctly tensioned.
Only in this state are correct operating pressures achieved.



WARRANTY

Kelly Engineering Guarantees its products against faulty workmanship and materials. Should any defects arise, Kelly Engineering will arrange at our discretion for the replacement or repair of defective parts.

Kelly Engineering is not responsible for freight charges incurred. This warranty excludes damage caused by misuse, mishandling in transit or normal wear and tear.

All Kelly Engineering products should be maintained according to the maintenance section in the supplied manual.

Any unauthorised modifications to the equipment will result in cancellation of warranty.

Statement of Policy

It is the Policy of Kelly Engineering to improve its products where it is possible and practical to do so.

Kelly Engineering reserves the right to make changes or improvements in design and construction at any time without incurring the obligations to make these changes on previously manufactured units.

Prices and specifications are subject to change without notice.

Warranty Card



Date of Purchase:
Model Purchased:
Serial Number:

For Sale, Service and Repairs please contact:

Kelly Engineering
PO Box 100
Yandiah Road
Booleroo Centre SA 5482

Ph: 08 86 672 253
Fax: 08 86 672 250
Email: office@kellyengineering.com.au
Website: www.kellyengineering.com.au

PLEASE KEEP THIS PART

PLEASE RETURN THIS PART TO KELLY ENGINEERING



Cut Here

Kelly Engineering Warranty Registration Card

Purchaser/Owner

Name:
Address:

Purchasing Details

Place of Purchase:

Date of Purchase:

Contact Number:

Model Purchased:

Email address:

Serial Number:

Purchasers Usual Occupation

Farmer Contractor

What bought Kelly Engineering Products to your attention? – Please select from the following

Field Day Stock Journal Magazine/Newspaper Phone Weekly Times
 Friend/Neighbour Seen in a paddock Demonstration Other

Fold Here

Is this your first Kelly Engineering product?

Yes No

What features do you like about Kelly Engineering Products? – Please select from the following

Design Price Australian Made Custom Built Options
 Construction Variety of Products Warranty User Friendly

Rate Product – Your impressions of: 1 Poor - 5 Excellent

Quality of Manufacture 1-5 ___ Quality of Finish 1-5 ___ Ease of Use 1-5 ___

Does it perform as expected 1-5 ___ Value 1-5 ___

Satisfaction with Dealer/Agent

Was machine Pre-Delivered satisfactorily Yes No Comment: _____

Were agents well informed about the product Yes No Comment: _____

Fold Here

Would you recommend the agent to other farmers Yes No Comment: _____



Please Affix
Stamp Here

Kelly Engineering
PO Box 100
Booleroo Centre
South Australia 5482